

ADVANCED LEAD ACID BATTERY DEVELOPMENT PROJECT

FINAL REPORT

FEBRUARY 1997

Prepared By:

**Sacramento Municipal Utility District
and
Electrosource, Inc.**

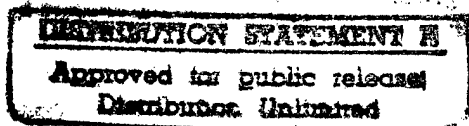

19970311 028

The project reported herein was sponsored by the Defense Advanced Research Project Agency. The content of the information does not necessarily reflect the position or the policy of the Government, and no official endorsement should be inferred.

DTIC QUALITY INSPECTED 3

ABSTRACT

This project involved laboratory and road testing of the Horizon® advanced lead acid batteries produced by Electrosorce, Inc. A variety of electric vehicles in the fleet operated by the Sacramento Municipal Utility District and McClellan Air Force Base were used for road tests. The project was sponsored by the Defense Advanced Research Projects Agency under RA 93-23 entitled Electric Vehicle Technology and Infrastructure.

The Horizon® battery is a valve regulated, or sealed, lead acid battery produced in a variety of sizes and performance levels. During the project, several design and process improvements on the Horizon® battery resulted in a production battery with a specific energy approaching 45 watt-hours per kilogram (Whr/kg) capable of delivering a peak current of 450 amps. The 12 volt, 95 amp-hour (Ahr) Horizon® battery, model number 12N95, was placed into service in seven (7) test vehicles, including sedans, prototype lightweight electric vehicles, and passenger vans.

Over 20,000 miles have been driven to date on vehicles powered by the Horizon® battery. Road test results indicate that when the battery pack is used with a compatible charger and charge management system, noticeably improved acceleration characteristics are evident, and the vehicles provide a useful range almost 20% greater than with conventional lead-acid batteries.

1. INTRODUCTION

In preparing the nation's defense forces for the battlefield of the future, the Department of Defense has recognized the need to improve ground vehicle propulsion systems. Previous studies have shown that electric vehicles offer substantial benefits in terms of signature reduction, improved compatibility with on-board systems, and simplification of the support logistics string. To further development of electric vehicle technologies, the Defense Advanced Research Projects Agency (DARPA) issued Research Announcement (RA) 93-23 entitled Electric Vehicle Technology and Infrastructure. The goal of RA 93-23 was to demonstrate the utility and efficiency of electric and hybrid electric vehicle technology for military use.

Current ground vehicle propulsion systems utilize internal combustion engines almost exclusively. The high energy density of fossil fuels (12,000 watt-hours per kilogram) makes internal combustion the power source of choice for today's ground vehicles. Internal combustion engines, however, have several disadvantages in defense applications. These engines have high heat losses, producing a large infrared signature. A whole spectrum of very effective weapons systems have been developed to identify, track and destroy sources of infrared emissions, and ground vehicles are no exception. In performing their role, these ground vehicles have a large complement of sophisticated electronic equipment operating on direct and alternating current. To power this equipment, auxiliary power units (and sometimes the main propulsion power unit) provide the needed electrical power through conversion of stored fuel. This conversion requires extra equipment and operating systems, taxing vehicle weight and reliability objectives. Finally, the use of fossil fuels as the primary energy source requires an extensive logistics string, since in-situ energy sources are quite often inadequate. Storing ground vehicle propulsion energy in electric form provides greater flexibility in the availability and use of in-situ sources.

While energy storage in electrical form is desirable, current technologies have limited weight and volume efficiencies, and advanced technologies with improved performance suffer from poor reliability. In the short to medium-term development time frame (5 years or less), secondary, or rechargeable, batteries offer the greatest potential as a deployable electrical energy storage technology. While several chemistries have shown promise, it is generally accepted that lead-acid batteries are the most mature of any technology currently available.

Electrosorce, Inc. (ELSI) has pioneered a new battery technology that takes advantage of the proven lead-acid chemistry while applying an advanced manufacturing technique to dramatically increase resulting battery performance. At the heart of this technology is a proprietary process for coextruding lead onto a high strength fibrous core that can be woven into a grid plate. These plates contain a high active material surface area resulting in greater battery energy capacity for a given mass of lead. The process is also highly amenable to automation, providing reliable construction and repeatable battery performance.

2. OBJECTIVES

This project was divided into two primary efforts:

- A. Manufacturing development of an advanced lead-acid battery
- B. Vehicle testing of pilot-production and production batteries

Battery Development:

The objective of battery development was to take an existing battery design and scale up manufacturing from the laboratory/prototype level to pilot-production and then production levels. Prior to this project, the Horizon® battery basic design had been established and the performance demonstrated in bench tests of individual cells and complete batteries. These early prototype batteries had been built by hand in Electrosource, Inc.'s research and development laboratory. An automated manufacturing facility was built in San Marcos, Texas to initiate production of the Horizon® battery. During this project, several design and process changes were incorporated to improve the performance and consistency of batteries produced in the new facility. Testing at independent laboratories measured battery performance, and the results provided guidance for subsequent product refinements.

Vehicle Testing:

Although laboratory tests had characterized battery performance, a more complete evaluation of the battery's potential required the batteries to be tested as a pack (or string) under real-world vehicle operating conditions. Previous electric vehicle experience had shown that batteries can demonstrate quite different performance when operated in a pack than when tested as individual batteries. The objectives of vehicle testing included measurement of vehicle performance for comparison with conventional lead-acid batteries, assessment of the new battery's reliability, evaluation of battery operation with adjacent subsystems (such as chargers and charge management systems), determination of battery operating constraints when operated in a vehicle, and development of vehicle design guidelines/recommendations for the use of Horizon® batteries.

3. PARTICIPANTS

The key project participants are identified below. Included is the organization title and address, project role, and contact person.

Organization: Sacramento Municipal Utility District (SMUD)
Electric Transportation Department
6301 S Street
Sacramento, CA 95817-1899

Role: Project management and administration. Provided electric vehicles for conversion to Horizon batteries and conducted road tests. Implemented charge management system on conversions.

Key Contact: Michael J. Wirsch
Phone (916) 732-6754 ; Fax (916) 732-6839
e-mail mwirsch@smud.org

Organization: Electrosource Incorporated
2809 Interstate 35 South
San Marcos, TX 78666

Role: Developed and produced Horizon batteries used on the project. Provided technical staff and facilities for battery manufacture and testing.

Key Contact: Bill Craven
Phone (512) 753-6500 ; Fax (512) 353-3391
e-mail bcraven@electrosource.com

Organization: McClellan Air Force Base
Environmental Management - Alternate Fuels Office
5050 Dudley Blvd, Suite #3
McClellan AFB, CA 95652-1389

Role: Provided electric vehicles for conversion to Horizon batteries and supported road testing.

Key Contact: Phil Mook
Phone (916) 643-5443 ; Fax (916) 568-6313
e-mail mook.phil@smal.mcclellan.af.mil

Organization: Institute of Transportation Studies
University of California, Davis
Davis, CA 95616

Role: Provided independent testing of Horizon battery modules and packs.

Key Contact: Dr. Andy Burke
Phone (916) 752-9812 ; Fax (916) 752-6572

4. FUNDING SUMMARY

The total cost of the project was \$715,192. Of this total, \$195,880 was provided by DARPA and \$519,312 was provided as matching contributions by the participants. This represents a matching rate of 2.65 to 1. Project expenditures are summarized in the Table below. Shown are project participants, their planned and actual expenditures and the % deviation from the plan. Also shown are the DARPA funds used and the matching contributions provided by the participants.

Participant	Total Planned Expenditure	Total Actual Expenditure	Deviation From Plan	DARPA Funds Expended	Matching Funds Provided
SMUD	\$275,015	\$334,364	22%	\$195,880	\$138,484
ELSI	\$253,398	\$363,918	44%	\$0	\$363,918
ITS	\$16,910	\$16,910	0%	\$0	\$16,910
Total	\$545,323	\$715,192	31%	\$195,880	\$519,312

5. BATTERY DEVELOPMENT

a. Horizon Battery Technology Description

The need for a higher specific energy, maintenance free, cost effective lead acid battery is the reason the Horizon® battery is in production today. Electrosource's high-performance Horizon® battery technology is based upon a patented co-extrusion process that creates a lead-coated fiberglass wire. The wire is then woven into a lightweight mesh, coated with a proprietary electrochemical paste, cut into grids, stacked horizontally, separated by absorptive fiberglass material and enclosed in a plastic box. The battery is filled with electrolyte, then drained, leaving just enough absorbed electrolyte to allow optimum electrochemical reactions to occur. The light-weight wire has high tensile strength and is able to use high purity lead, resulting in a long-life, high specific energy, maintenance free, rechargeable battery. The modular technology can be reconfigured quite easily to the power, capacity, and sizing requirements of various applications.

The electrochemical system of the Horizon® advanced Valve Regulated Lead Acid (VRLA) battery is similar to other VRLA batteries. The electrode reactions in other VRLA batteries are as follows.

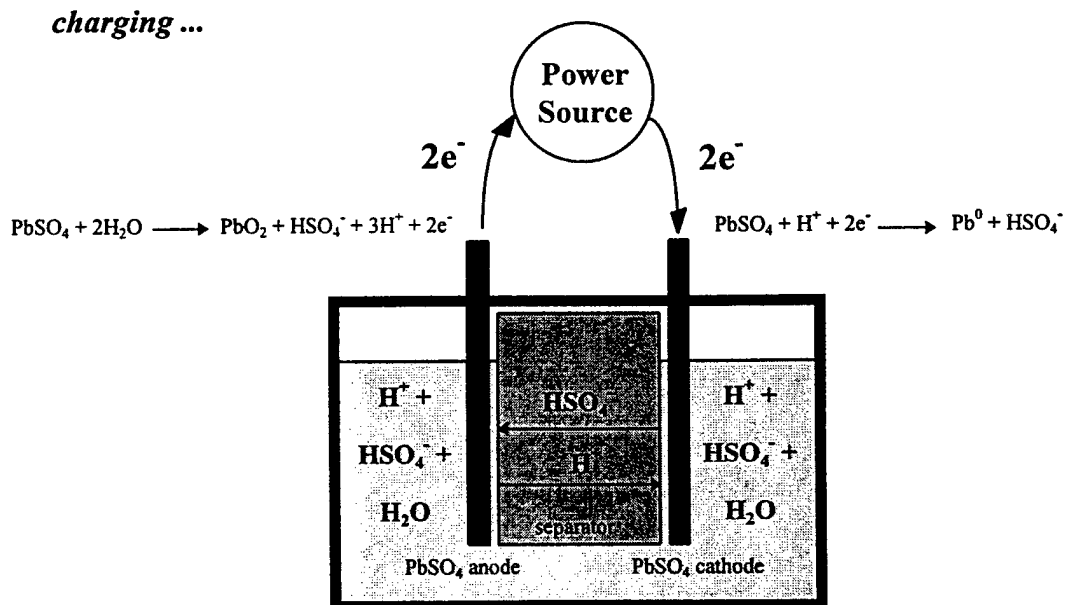

discharging ...

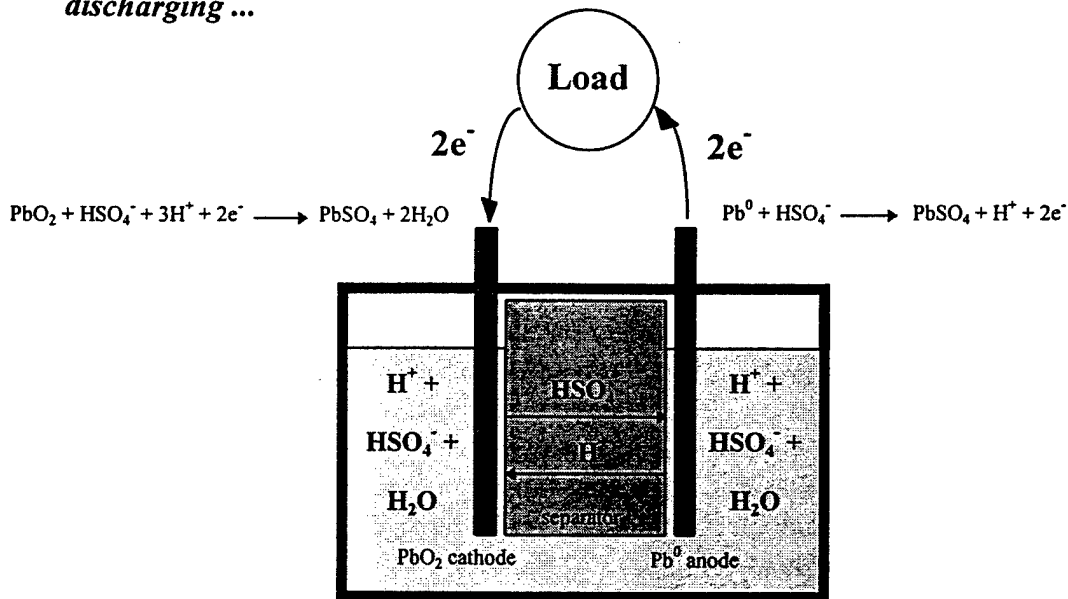

There are two major limitations with other VRLA batteries: cast grids; and vertical plate orientation.

■ **cast grids...**

- must be thin to reduce internal resistance
 - no win with thin...grid growth
 - positive plate failure via fracture
- lead alloys used to reduce grid creep rate
 - upset cell electrochemistry
 - susceptible to intergranular corrosion

■ **vertical plate orientation...**

- electrolyte concentration gradients
 - encourage non-uniform resistance distribution
 - form hot spots, overwork active material, shorten life
 - reduce specific performance via partial material utilization

Electrosource overcame these two major limitations by inventing the coaxial lead fiberglass wire, a woven grid and horizontal bipolar plate design.

● **coaxial lead-fiberglass wire**

- dimensionally stable, no creep (dia = 0.5 - 0.75 mm)
- dense, fine grain structure (Pb-0.5% Sn) resists intergranular corrosion
- pure Pb is possible
- 50% less weight than cast grid

- **woven composite-wire grid**
 - quasi-bipolar design
 - reliable series cell connection integral to bipolar grid
 - thickness from ~ 0.75 mm
 - mesh dimensions as required
 - mfg process allows metal/non metal mesh for wt control

- **horizontal bipolar plates**
 - eliminates resistance gradients across plate surface (no hot spots)
 - during fabrication
 - in service
 - spatially uniform active material utilization
 - "stiff" Voltage under high discharge current
 - low recharge Voltage
 - highest energy efficiency
 - graceful active material aging
 - shortest and most direct Oxygen recombination path to negative electrode
 - highest Coulombic efficiency
 - thinnest deep cycle plates

The following diagrams show how the horizontal Horizon® cell reactions occur on charge and discharge.

charging the Horizon sealed, oxygen recombinant cell

- oxygen gas evolved during overcharge is electrochemically reduced at the cathode during charge, and recombines with H^+ to reconstitute water.
- during overcharging conditions, Hydrogen gas will be evolved in extremely small amounts. There is no recombination mechanism for evolved Hydrogen gas.

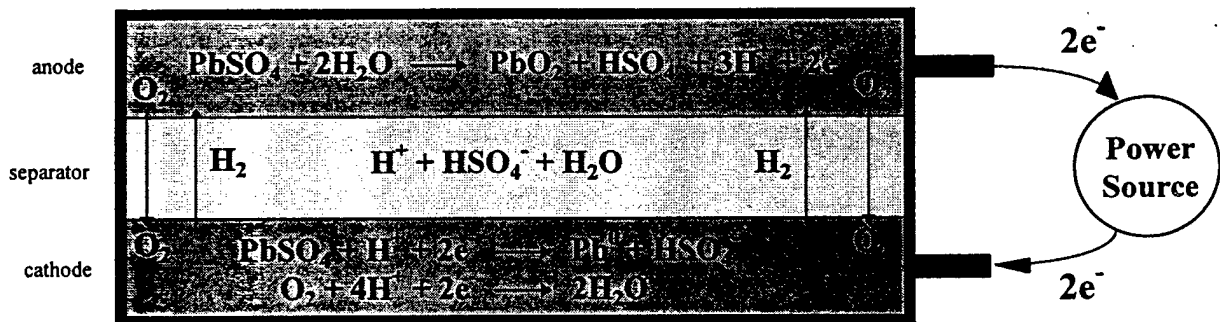

discharging the Horizon sealed, oxygen recombinant cell

- discharging the PbO_2 cathode produces H_2O and $PbSO_4$.
- discharging the Pb^0 anode produces $PbSO_4$, soluble Hydrogen ion and electrons.
- note that the discharged condition of lead in both electrodes is $PbSO_4$.

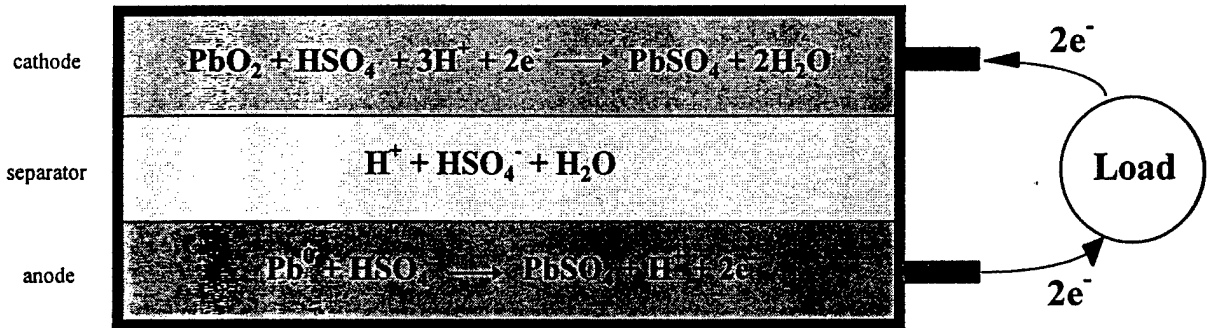

The operating temperature range is $-30^\circ C$ to $50^\circ C$ ($-22^\circ F$ to $120^\circ F$). Cell Open Circuit Voltage (OCV) is 2.17V per cell at 100% state of charge @ $80^\circ F$. Theoretical maximum specific energy is **161 Wh/kg**.

An eight volt configuration is shown below to demonstrate how a battery is designed using horizontal bipolar plates:

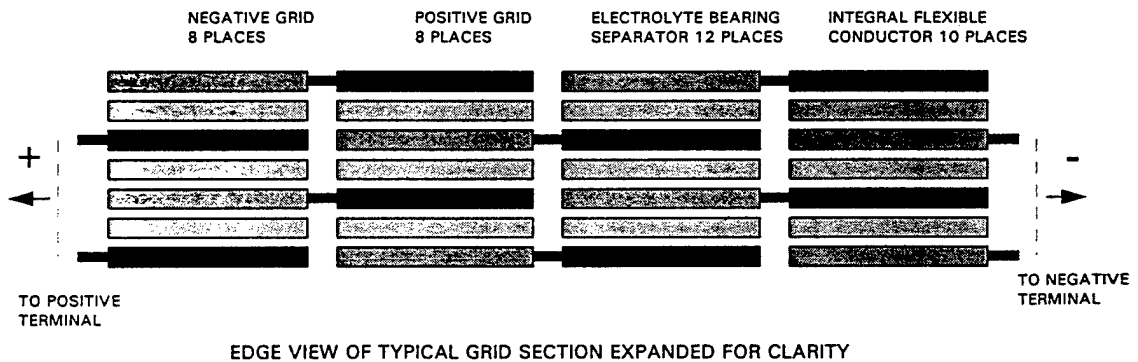

Based on extensive testing of R & D modules, ELSI has established that its present production grid, horizontal configuration and its proprietary paste formulation are capable of achieving C/3 cycle life well in excess of 1,000 cycles and specific energy of 60 Whr/kg.

b. Process Development

Taking a four volt, hand built prototype battery and making it into a twelve volt production battery was not an easy task. The potential show stopper going into production was the pasting of the plates. The paste had to be applied to both sides of the mesh within a very tight tolerance. A well established battery machinery supplier was asked to help accomplish this difficult task. Working closely with Electrosorce engineers they were able to modify an existing piece of equipment to do the job. After the first trial run it was determined that the paster would exceed specification requirements, and pasting of the plates was no longer a show stopper.

There were other positive outcomes of the paster. The paste material had to be modified so it would flow easier. The additive to modify the paste increased the utilization of active paste material, increasing the specific energy. Terminal casting was first thought to be easy but turned out to be one of the most difficult processes to perfect. A bad terminal connection causes decreased power and local heating. These failures were experienced in field testing of early production batteries. The challenge of connecting 544 wires together uniformly and without melting the lead off the fiberglass was overcome after nine months of trial and error.

c. Manufacturing Facilities

Development Laboratory:

Electrosorce has established a state of the art battery testing facility in Texas. There are 38 battery test stations capable of performing any type of charge and discharge required for an individual battery test. An environmental battery pack test chamber can operate up to 36 batteries connected in series to simulate an electric vehicle pack. The pack tester is also capable of testing battery management systems in a realistic working environment. An autopsy lab was also constructed complete with audio/video recording capabilities so that all aspects of the battery teardown could be reviewed at a later date if necessary.

Along with the battery test facility is a low rate prototyping manufacturing line. Batteries can be made to customer specifications for trial testing. The prototype line is also used as a method for trying out improvements to the production battery before implementing the changes on the production line.

Pilot Production Factory:

ELSI began design and construction of specialized plant and machinery for the mass production of the 12-volt Horizon® battery in April, 1993. As the specified machines were completed, they were installed in a 75,000 square foot pilot manufacturing facility in San Marcos, Texas. The overriding objective of the pilot production facility was to prove that the inherent design of the Horizon® battery (including the patented paste formulations) allowed

for continuous flow (as opposed to batch) manufacturing techniques between grid manufacture and completed battery. A secondary objective was for the manufacturing plant to have zero environmental impact.

By June, 1995, ELSI had proven that these concepts were viable and a production rate of 200 12-volt modules per day was achieved. ELSI is continuously in the mode of revising certain of the fabrication processes to eliminate weak links in the series of manufacturing steps. The target is uninterrupted, continuous flow manufacturing of 500 12-volt batteries/day in the production facility (San Marcos). Revisions to the machinery necessary to meet this objective have been identified and ELSI expects to install such machinery and be in a position to manufacture 500 batteries/day by the end of 1997.

d. Battery Testing

Laboratory Tests:

In December 1994 through June 1995, laboratory testing of the Horizon® battery was performed at the University of California, Davis Institute of Transportation Studies (ITS). Initial tests were conducted on an individual battery to establish reference performance. This was followed by pack tests to evaluate battery performance in a multi-module string.

Initial tests utilized a selected Horizon® battery, serial number 476. These tests established performance as a function of discharge rate (constant current and constant power), temperature effects, self discharge rate, DST and number of cycles. A comparison of the performance between the reference battery and other lead acid batteries was made.

These tests showed that the Horizon® battery has a high coulombic efficiency. When compared to other sealed lead-acid batteries, the reference Horizon module also showed :

- high specific energy;
- low self discharge;
- very low internal resistance; and
- a flat Ragone Curve.

These characteristics indicate that discharge at a high rate does not significantly reduce available energy. In fact, the performance of the reference Horizon® was close to some nickel cadmium batteries.

Following the reference module tests, pack testing was initiated utilizing "pre-production" battery modules. Performance was measured using both series and parallel measurement techniques on a battery pack installed in a Solectria Force electric vehicle. Laboratory tests using two groups of pre-production batteries were also conducted, and the C/3 performance of each individual battery measured to evaluate module to module consistency across the pack. (note: C/3 is an industry standard for rating electric vehicle batteries -- it means the number of amp-hours that can be delivered at a constant current discharge for 3 hours to 100% depth of discharge.)

Initial pack tests found module amp-hour capacities well below the Electrosource specification. This was traced to a change in the formulation process for the pre-production batteries. Another relevant factor was the charging method (algorithm) used. Following initial pack tests, the algorithm was changed to a "halving current" method.

A new set of 12 Horizon® batteries (with serial numbers between 3635 to 3738) was provided to the ITS, and pack tests were repeated. The performance of these batteries far exceeded the capacity performance of all previously tested Horizon® batteries. Further, the variance in individual battery performance was small. The amp-hour capacity of these modules was within 95% of the Electrosource specification, with the C/3 capacity projected to increase during continued cycling.

Results of the laboratory testing performed at ITS is provided in **Appendix A**.

Pilot Production and Field Tests:

From the commencement of volume production in its San Marcos, Texas manufacturing facility, ELSI has been selecting production modules at random every week for life tests (SFUDS/DST and constant current cycling). At the end of life (defined as 80% initial capacity), each one of these modules has been subjected to a thorough autopsy to determine the precise failure mode. In parallel, SMUD has been testing the batteries in vehicles with autopsies performed on selected failed or end of life batteries.

Based on results obtained from teardown and analysis of these modules, a number of steps have been taken to correct life limiting design and process-related features of the early production batteries. The primary modes of battery failure due to early manufacturing and design were the following: lead dendrites (shorting), acid fill (cell imbalance & shorting), tin dendrites (shorting), chemical impurities (low capacity), ionic paths (high self discharge). With each one of these problems an initial solution was tested, but several times the solution caused a more severe problem. Final solutions were eventually found, and verified through long term testing, giving the product consistently high performance.

The primary modes of failure uncovered during field testing were also daunting, not only for the Horizon® battery but all batteries used in electric vehicles. With so many new components being tested at one time in an electric vehicle, the battery was often overstressed and damaged. Excessive charging from regenerative braking or the vehicle charger, undercharging, inaccurate state of charge meters causing overdischarge, component failures leaving batteries in a discharged state, and improper implementation of charging algorithms all led to premature capacity loss and shortened life.

One battery mechanical failure occurred early on. The pressure release valve would stick allowing pressure to build up inside the battery causing deformation (bulging) of the case. The pressure was produced by gasses formed through high discharge rates and overcharging. Though functionally harmless, it caused concern for many customers.

e. Product/Process Improvements

Many battery industry professionals were convinced the Horizon® battery would never work since the cells are not partitioned as in all other batteries. This would cause ionic paths creating a high self discharge rate. This was the only major design concern that ELSI had going into production.

Battery shelf life is a critical characteristic. For this discussion, "shelf life" is defined to be the period of time (measured in days) following manufacture in which a battery can be placed into service and deliver a useful initial discharge without first being charged.

In the development phase of the Horizon® battery, 4 Volt modules exhibited open circuit stand of approximately six months at 80°F (see chart below). Extensive open circuit stand tests of the 12 Volt production modules are presently showing over one year shelf life, very close to industry standard.

The Table below shows self discharge characteristics of both R & D and production Horizon® batteries of various sizes and designs.

Test Results Status	Testing Agency	Test Configuration	Self Discharge Rate (mv/cell/day) 80°F
R & D Phase	ELSI	4 Volt, 40 Ahr	0.7
Initial production	ELSI	12Volt, 95Ahr	2.7
Production	ELSI	12 Volt, 85 Ahr	0.35
Industry Standard	ELSI	12 Volt, 85 Ahr	0.25

Specific problems encountered during the Horizon® battery development and the resulting product/process improvements are described in the following paragraphs:

Lead dendrites:

The first process problem caused very high self discharge rates (shelf life 30 days). Lead dendrites were formed in the battery during the formation process causing the high self discharge. ELSI did not have a self discharge test as part of the qualification process so many batteries were shipped before the problem was identified by SMUD. The formation process used too deep a discharge in forming the batteries causing the lead dendrites. The process has been changed as well as the paste to allow fast formation without using a deep discharge. Shelf life improved to sixty days.

Acid fill:

Acid is flooded into the battery absorbed by the separators and the excess acid is then drained off. The initial drain holes did not allow complete drainage of acid leaving a puddle at the

bottom of the battery. This caused a short. Larger holes and inspection resolved this problem. Shelf life improved to three months.

Tin dendrites:

A small amount of Tin is used in the end plates that connect all the plate wires to their prospective terminal. A crude separator process that needed eight people to operate was initially used to wrap the separator around the pasted plates. The separator is a porous glass mat that adsorbs and holds the acid in-between the pasted plates. If the separator was not positioned correctly it would touch the end plate. The acid from the separator would leach out the Tin from the end plate causing a dendritic short between pasted plates. The solution was to use a robotic arm, operated by just one person, that could achieve consistent separator position accuracy. Shelf life improved to six months.

Ionic shorts:

This was the dreaded show stopper cited by the battery experts. After a detailed investigation, two causes of ionic shorts were identified and minimized by the same solution. An inert bituminous coating is applied to the exposed grid wires. The shelf life is now over one year and within industry standard.

Acid fill:

Another problem was later found with the acid fill process. Tilting of the battery helped the acid fill and drain process. By tilting the battery during fill, however, an air pocket would sometimes form causing a shortage of acid in a stack of cells. During subsequent battery use, the dryer cells would run out of acid before the others causing them to heat up resulting in premature failure. The batteries are now filled level, then tilted just for drainage.

Chemical impurities:

Early on ELSI relied on the suppliers word that the incoming chemicals and materials were in spec. As it turned out, too often they were not in spec. Acid and lead impurities were random and often caused poor cycle life. In ELSI's contract with a vehicle OEM, ISO 9000 had to be implemented resulting in improved quality control and independent testing of supplier materials. After rejecting many shipments of materials from suppliers, they learned to ship only those that met specification requirements.

Pressure release valve:

The pressure release valve had a spring loaded diaphragm that should have opened at 6psi to release the internal pressure. The valves were not made to spec and would stick or release at 12psi. A new valve was designed to release at 1.5psi and quality controls imposed weed out the defective parts. The issue was more of a cosmetic one rather than affecting the performance of the batteries. Customers did not like the batteries bulging at the sides. They like square corners and flat sides. The case used for the Horizon® battery is thinner than the rest of the industry and is capable of significant distortion. Most other batteries do bulge when overcharged, but not to the extent observed in early Horizon® modules.

f. Pack Integration

SMUD and ELSI realized early on that a charge management system (CMS) was necessary to achieve acceptable battery life in an electric vehicle. The function of a CMS is to keep all the batteries at the same state of charge and prevent overcharge and overdischarge.

Overcharge is undesirable for any VRLA battery, particularly at high rates, since it can cause water to be lost from the battery resulting in an unnecessary decrease in life. Since the Horizon® VRLA battery is an acid starved system, it is recommended that the battery be promptly recharged following a full discharge. Lead species solubility increases irreversibly in the low specific gravity acid environment of the discharged condition. Allowing extended stand in a discharged state, therefore, may lead to the development of lead dendritic shorts. The recharge algorithm developed for the Horizon® battery ensures that recharge is completed at a low finishing current. The typical temperature rise is only about 7°F during a normal recharge helping save energy and extend life.

The operation of the CMS and the preferred charge algorithm are described in the Horizon® Battery Users Manual (**Appendix B**). The need for an effective and reliable CMS is paramount. The cost of such a device is insignificant compared to the savings it provides through battery cycle life extension. ELSI envisions that the CMS will be an integral part of the vehicle's electrical/electronic system regardless of whether an on- or off-board charger is used.

With the inclusion of the CMS as part of the vehicle's electrical/electronic system, the infrastructure requirements for central or remote charging will be very much simplified. As an example, the conventional domestic electrical outlet can deliver 6.6 kVA (30 Amperes x 220 volts). A typical Horizon® EV battery comprising twenty-seven 12-volt batteries in series (324 volts total), each battery having a capacity of 85 Ampere-hours (C/3), can absorb an initial charge current of 100 Amperes (DC) without damage to the battery. However, the domestic outlet can deliver at best $6,600/324 = 20$ Amps on the DC side of the charging rectifier. Under these conditions, a recharge to 100% SOC from a 100% DOD condition will take 7.5 hours.

With well-designed central charging locations capable of providing a DC charge current of 100 Amperes, the Horizon® recharge period is reduced to 3.5 hours. With adequate power, the Horizon® can recharge to 85% SOC in 30 minutes. The CMS is designed to control the recharge process and protect the battery against overcharge regardless of the magnitude of the initial charge current.

Failures of one or more batteries in a string before the total pack reaches the defined end-of-life capacity of 80% of nominal are certain to occur. On-board computers will readily identify which batteries in the string need replacement. It is envisioned that existing lead-acid battery service facilities will be available to provide both curbside and home battery diagnostic and replacement services. These facilities will also be available to dispose of "spent" EV batteries - a service that has resulted in the recycling of more than 95% of lead in batteries in the USA.

6. VEHICLE TESTING

a. Vehicle Test Approach/Objectives

A vehicle test program was undertaken to evaluate the Horizon battery performance under real world driving conditions in a variety of vehicle applications. Test vehicles were provided by SMUD and McClellan AFB. An initial goal was to include not only a variety of test vehicle configurations, but a range of services as well to better simulate real world fleet applications.

The vehicle test plan is outlined in **Appendix C**. The vehicles included in the test program are identified below:

Test Vehicle No.	Vehicle Designator	Manufacturer	Model	Year	Service
1	M01	Solectria	Force	1993	EM Fleet - On Base
2	E036	Horlacher	Sport	1993	Data System Test
3	E037	Horlacher	Pickup I	1993	EM Fleet - On Base
4	E038	Horlacher	Pickup II	1994	Ride & Drive Demo
5	E684	Conceptor	G-Van	1990	Commuter Van Pool
6	E685	Conceptor	G-Van	1990	Commuter Van Pool
7	E686	Conceptor	G-Van	1990	Commuter Van Pool

An important aspect of the test program was the evaluation of vehicle chargers and charging control systems to assess their effectiveness relative to life (and life cycle costs) of the Horizon® battery. The test program, which integrated as many as 36 batteries into a pack, also evaluated the Radsock terminal connector recommended by Electrosource.

The test vehicles were equipped with the Badicheq charge management system. This system not only controlled the vehicle charge cycle, but recorded important data enabling assessment of battery performance and life.

Following Horizon® battery and Badicheq charge management system installation, the vehicles were cycled under controlled conditions to "break in" the battery pack and build capacity to its maximum level. The vehicles were then put into service. Badicheq data was downloaded regularly and reviewed to assess battery pack performance and health. Range tests were conducted as well to quantify battery pack capacity.

b. Vehicle Conversions

Solectria Force

The first test vehicle to be converted to Horizon® batteries was a 1993 Solectria Force (Geo Metro). The battery pack is comprised of 12 model 12N95 (12 volt; 95 amp-hour) batteries in series for a total pack voltage of 144 volts. Each battery weighs 60 pounds (27.5 kg). The

total battery pack weight is 720 pounds (330 kg), not including the weight of the battery containment boxes, cables, and ventilating fans. The total pack is rated at 13.7 kilowatt-hours (kWh) at the C/3 discharge rate.

Battery containment boxes are located both in the front of the vehicle (under the hood), and in the rear deck of the hatchback. Due to the unique envelope of the Horizon® battery, a new rear battery box had to be constructed and the front box modified to accommodate 2 layers of batteries. The original Solectria charger was replaced with a Mentzer 3kW charger operating off of 208/240 volt 40 amp service. Peak charger output is approximately 16 amps. The Badicheq Charge and Discharge Equalization System (Drake Associates) was installed to control vehicle charging and provide data on battery pack performance and operating history. A detailed report of this vehicle conversion is provided in **Appendix D**.

Conceptor G-Van

Three Conceptor G-Vans were converted to Horizon® batteries for use in SMUD van pools. The G-Van battery pack is made up of 36 Model 12N95 batteries assembled in a series string of battery pairs wired in parallel. Total pack voltage is 216 volts. The battery pack weighs 2178 pounds (not including the weight of the battery tray and cables) and replaces a battery pack weighing 2520 pounds. The total pack is rated at 41 kilowatt-hours (kWh) at the C/3 discharge rate.

The batteries are contained in a special tray designed specifically for the Horizons. Built by Standard Industrial Works, Inc. (New York), the tray is constructed from reinforced, square-tube steel, and bolted to the underside of the van. The batteries are placed in a transverse orientation in two layers and are held in place with a retaining structure passing over the top of the batteries. There is no top or final enclosure, leaving the batteries exposed to the external environment. The battery pack is charged using an off-board charger consisting of a 10kW Chloride charger (used with the original batteries) and a 3kW Mentzer charger installed inside the Chloride charger case. The overvoltage limit on the Chloride charger turns off the bulk charge when the pack reaches 14.25 volts. The Mentzer charger continues to operate to finish the charge under control of a Badicheq charge management system. A detailed report of the G-Van conversion is provided in **Appendix E**.

As part of the G-Van conversion, a crashworthiness evaluation of the tray was performed by Transmotive Technologies, Inc. of Santa Rosa, CA. This included computer simulation using nonlinear finite element methods to predict crash behavior. Transmotive recommended that reinforcing flanges be incorporated in the tray front bulkhead to reduce bending in a frontal crash. These flanges were incorporated in the G-Van trays prior to battery installation. With this modification, study results show that the new Horizon battery tray design adequately maintains structural integrity and battery containment in a 25g frontal crash, performs well under vertical jounce loads, and the reduced battery/tray weight has a beneficial effect on crashworthiness.

Horlacher Composite Electric Vehicles

Three purpose-built composite electric vehicles, manufactured by Horlacher AG, were used as test vehicles on this project. These include the Sport, Pickup I, and Pickup II. The vehicles were either converted to or originally manufactured with Horizon® battery packs. A description of the Horlacher conversions is provided in **Appendix F**.

The Sport and Pickup I battery packs contain 12 model 12N95 batteries in series for a total pack voltage of 144 volts. The batteries were split into two boxes, one forward and one aft. The Pickup II battery pack contains 14 model 12N95 batteries in series for a total pack voltage of 168 volts. The 14 batteries are contained in a single box integral with the vehicle structure, running from under the passenger seat into the pickup truck bed area.

All the Horlachers are charged with a 3kW Mentzer charger operating from a 220 vac, 20 amp (minimum) service. The Mentzer charger is controlled by the Badicheq charge management system, which also provides the operator with discharge information during driving to prevent overdischarge of (and premature damage to) the battery pack.

c. Vehicle Test Results

Range Testing

Range tests were conducted on four of the test vehicles. Vehicle range was quantified during single tests of the Solectria Force, the Horlacher Pickup II, and G-Van number E686. Two separate range tests were performed on the Horlacher Sport. A detailed report of the range testing conducted is provided in **Appendix G**.

A 45 mile per hour constant speed test was used to quantify vehicle range. This test was chosen to enable comparison with vehicles undergoing similar testing for EV America. The California Highway Patrol Test Track in West Sacramento was used for the range tests. It is a 1.8 mile moderate speed closed track with one small banked curve and one small elevation change.

Starting with a fully charged vehicle, range testing was begun by accelerating up to 45 miles per hour (mph) on the test track and then maintaining the 45 mph speed until the batteries were discharged to 20% state of charge (80% discharge). Because the track was not perfectly flat and contained some curves, it was only possible to maintain a speed of 45 mph on approximately 75% of the track.

Two vehicles, the Solectria Force and Horlacher Sport, are equipped with dash-mounted auxiliary potentiometers that can control the speed manually by limiting the controller current output. This feature enabled the vehicles to be driven with a much more consistent discharge current. In the Horlacher Pickup II and G-Van, there was no auxiliary potentiometer to control current and the resulting discharge current fluctuated quite a bit as the drivers sought to hold the 45 mph constant speed. These differences are evident in the current plots provided in Appendix G for the vehicle range tests.

Lead acid batteries have a very consistent relationship between discharge current, voltage and state of charge, known as the Peukert relationship. Previous discharge tests on the Horizon battery were used to determine what voltage would be reached at a particular current after discharging a given amount of amp-hours. For range tests, these results were used to calculate end of test voltage at the 45 mph discharge current. For example, the Horlacher Sport required a 42 amp discharge current to maintain 45 mph. At this rate, a Horizon battery would be 80% discharged when the voltage reaches 11.5 volts or 1.933 volts per cell. This value was then used as the test termination voltage.

In every case, the average pack voltage was still above the cutoff voltage, but the tests were terminated because one or two of the weaker modules reached this cutoff voltage first. For example, in the Horlacher Pickup II, battery #7 reached the cutoff voltage at 88 miles, even though the average pack voltage was 1.96 volts per cell (or 11.76 volts per module), implying only 70% depth of discharge (DOD).

The Badicheq calculates the capacity discharged from the pack and compares that to the usable capacity (80% depth of discharge based on Electrosources' specified capacity of 95 amp-hour at C/3 at 77°F). This number, reported under the Badicheq output column labeled "QM", is updated every time the Badicheq takes a voltage measurement. A QM of 80 would indicate that you have discharged the battery pack to 80% DOD. However, with the performance differences experienced in test battery packs, the minimum voltage was achieved long before 80% DOD.

A summary table of the vehicle range achieved under the above conditions is provided below:

	Solectria Force	Horlacher Sport	Horlacher PU II	G-Van
Current needed to maintain 45 mph	50 amp	42 amp	50 amp	80 amp
DC wh/mi used	159 wh/mi	120 wh/mi	146 wh/mi	820 wh/mi
Ending QM (DOD)	73	66	70	**
Miles Achieved	64 miles	94 miles	88 miles	40 miles
Optimal QM	80	80	80	80
Miles predicted with full charge and balanced pack	70 miles	114 miles	101 miles	54 miles

** Capacity not calibrated for G-Van battery pack

Following replacement of its battery pack, the Horlacher Sport was range tested a second time. The cutoff voltage of 1.933 volts per cell was reached after 91 miles, or within 3% of the range achieved on the initial test with a different battery pack.

Charger Power Quality Testing

Of interest to electric vehicle users and the utilities who will be providing the necessary power is the efficiency of the vehicle charger. Whether this charger is located on the vehicle or off the vehicle, it will still have a substantial effect on the electrical distribution system to which it is attached. High power quality is desired by both the charger owner (or the person paying for the power) and the owner/operator of the distribution system (the utility).

To that end, power quality testing was conducted on three electric vehicle chargers. The first is a 3kW Mentzer conductive charger without power factor correction located on-board the E005 Solectria Force, the second is a 3 kW Mentzer conductive charger *with* power factor correction located on-board the E037 Horlacher Pickup I, and the third is a 6.6 kW Hughes inductive charger located off-board but used in conjunction with GM Impact #48.

The test vehicles were discharged to 80% DOD and then the charge cycle was recorded. Charging voltage in each case was 208 volts single phase. The recording instrument was a Basic Measuring Instrument (BMI) 3030 made by Fluke Instruments. Power quality tests on the three candidate chargers were performed in November 1994 by SMUD's Power Quality Department.

A report of the power quality tests is provided in **Appendix H**. Summary results are provided in the table below:

	E005 3 kW Mentzer charger without PF correction	E037 3 kW Mentzer charger <i>with</i> PF correction	Impact #48 6.6 kW Hughes inductive charger
Instantaneous Power (Max)	2.5 kW	2.4 kW	6.4 kW
Power Factor (Ave)	0.55	0.87	0.86
Current Imbalance (Max)	17.3 amp	17.3 amp	30.5 amp

note: Power factor values were measured during the bulk charge phase after charger stabilization.

Badicheq CMS Performance

Even the most highly efficient (high PF) charger will not work well with an electric vehicle battery system if it is not integrated effectively.

A battery management system was proposed for use on test vehicle battery packs. The system is designed to control charging of sealed battery modules such that lower voltage modules are charged preferentially, thus minimizing module imbalance problems and avoiding excessive charging of higher voltage modules. The system also serves as a state of charge indicator and a low level data gathering system.

Electrosource recommended use of the Badicheq, the only battery management system available which met their desired charge control criteria at the inception of the field test project. The data collection feature of the Badicheq also allowed Electrosource to evaluate how the batteries were being used in the field test vehicles.

The Badicheq system performed the following functions:

1. *Charge Control* - The Badicheq microcontroller contains an embedded program to control the charge profile based on the specified algorithm. A variable 2kHz pulse width modulated (PWM) signal regulates the charger current output, with control based on individual module voltage to prevent overcharge. In this situation, the charger acts as a "slave" under control of the Badicheq.
2. *Charge Equalization* - Following the bulk charge process, the Badicheq provides a low power equalizing charge to undercharged modules using a small integrated charger. Historical battery pack data recorded by the Badicheq is processed through proprietary software to determine which modules are of low capacity. A preferential charge of up to 5 amps is provided to as many as four modules using the 20 watt internal charger.
3. *State of Charge Status* - The Badicheq provides output of the pack state of charge, accurate to 5%, giving the vehicle user information for terminating the discharge. To accomplish this, it measures the voltages of each module, compensates for temperature of the battery, measures the discharge current once a second, and calculates amp-hours based on the measured rate of discharge and the Peukert battery model. With this data, Badicheq then performs an elaborate computation, calculating the expected SOC based on the "reference capacity" of the battery pack, and provides real-time feedback to the vehicle user via an analog or digital gauge.
4. *Battery Condition Monitoring* - The Badicheq can monitor the voltage and temperature of up to 60 cells or modules in a battery pack and the current running through the pack. It does this using a 16 gauge wire attached to the positive terminal of each battery module and routed to the Badicheq microprocessor. A temperature sensor is situated in each of as many as three discreet battery locations and a dedicated current shunt is wired in-line near the Badicheq. Accessing the condition of the batteries is performed using Badicheq software on a remote PC interfaced with a D-SUB jack interface and an RS232 cable.
5. *Data Collection for Battery Diagnostics* - The Badicheq collects and records battery pack data and provides the data in a diagnostic summary of 128 charge/discharge cycles in a variety of output formats, or "screens". Historical data is provided in numeric format only which presents some limitations, however data for the most current cycle can be displayed graphically and stored separately for later use.

SMUD installed a Badicheq in each of the seven Horizon battery field test vehicles with generally good results. The Badicheqs are robust and never failed on a vehicle or during installation. The data processing and analysis of the output presented some challenges,

however. The output screens are not intuitively obvious. Substantial experience with and study of the data was necessary before their value in battery diagnostics could be fully utilized. Problems were encountered in interpreting the data from the Badicheq output screens and in the numerous changes in charging configuration that were implemented as part of the program. An adequate Badicheq user manual was not provided until January 1996. Had this manual been available earlier, many of these problems could have been avoided.

In total, the Badicheq performed as advertised. It provided all the functions defined above and proved extremely reliable throughout the field test program. A comprehensive report of the Badicheq performance, including guidelines for installation and operation is provided in **Appendix I**.

Charge Algorithm Development

With the initial battery deliveries, Electrosorce recommended that the Horizon battery be charged at 60 amps until the gassing voltage is reached. While this may minimize recharge time, this current level is considered impractical given today's on board charger technology. On board chargers typically operate at 3 to 4 kW. Given the electric vehicle pack voltage of 120-160 volts (considered a minimum for reasonable vehicle performance), this corresponds to a maximum current of 25 amps. In our applications, using the 3 kW Mentzer charger (operating at about 2.5 kW) and 144 volt battery packs, the maximum charge current is just over 12 amps.

The initial charge algorithm called for constant current charging until the temperature compensated clamp voltage is reached (14.25 volts at 25°C, compensation of 0.0216 volts/module/°C with voltage increased for temperatures below 25°C, voltage decreased above 25°C). At this point, the voltage is held constant until the current has tapered to 1 amp. The 1 amp current is then held constant until the voltage reaches its second clamp voltage of 15.5 volts. This initial CI/CV/CI charge algorithm (or profile) was designated Version A. An example vehicle charge cycle using the Version A algorithm is shown in Figure 1. EPROM memory chips installed in the Badicheq CMS to control the charge were programmed with this algorithm. In addition to charge control, the Badicheq also performed an initial equalization (preferential charging) of the four lowest capacity modules during the initial constant current (CI) phase.

Following initial vehicle conversions and testing, Electrosorce developed a new recommended charging profile based on halving the current (or a series of current steps). Starting with a current of 40 amps (or the maximum delivered by the charger if less than 40 amps), this rate is held until the module reaches the temperature compensated maximum voltage. The current is then cut in half and the procedure repeated. When the current reaches 1 amp, the current is held at this level until the voltage reaches its second clamp voltage of 15.5 volts.

The new stepped profile, called Version B, was programmed into EPROM memory chips which were in turn installed in the vehicle Badicheq charge management systems. This

CHARGE CYCLE

E-037 Jan 25 1996

Version A EPROM

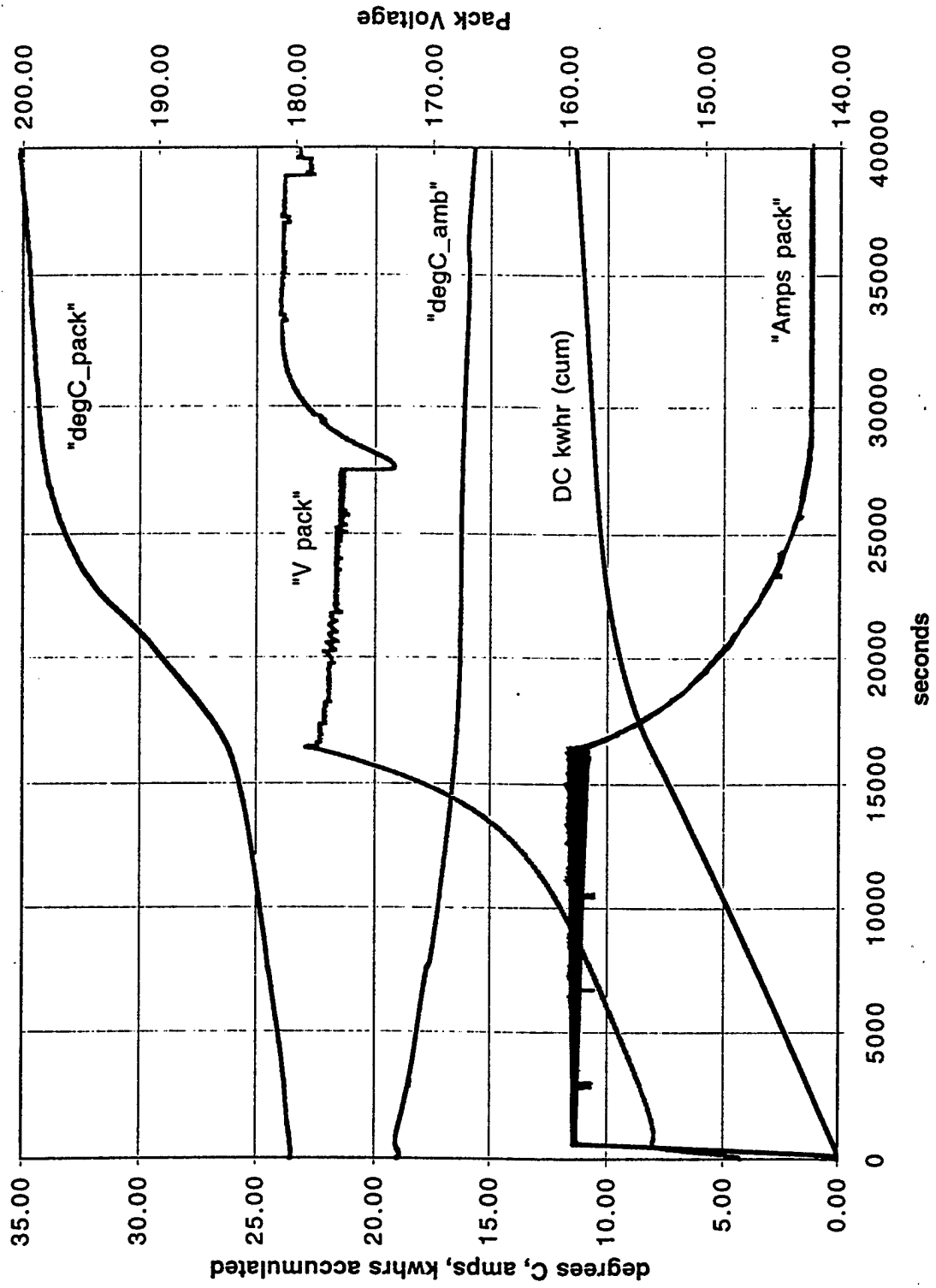

Figure 1. Example Vehicle Charge Cycle Using the Version "A" Charge Algorithm

profile was adopted in an effort to reverse the reduction in capacity which had been experienced in some modules. The SMUD test vehicles were used as a beta-site for testing of the new Version B multi-step charging profile. An example vehicle charge cycle using the Version B algorithm is shown in Figure 2.

Shortly after the change, problems were identified with the new EPROMS assumed to contain the Version B charging profile. While observing charge cycles (output from the Badicheq system), it was discovered that the EPROM had not been programmed as specified by Electrosource, resulting in continuous undercharging for each of the charging steps. This problem was discussed at length with the Badicheq manufacturer, and it was concluded that the EPROMS could not be programmed to perform as specified by Electrosource.

At this point it was decided to return to the CI/CV/CI profile, however an additional equalization was performed by the Badicheq during the second CI phase. This modified charging profile, called Version A-2, was developed and intensive pack tests were performed with a Version A-2 EPROM. The charging profile was found to correct the poor results from the installation of the Version B EPROMs. The Version A-2 EPROM was installed in all but one of the test vehicles. This corrected the poor capacity (and assumed life degradation) problems and each of the battery packs are now performing well.

The integration of the G-Van charger required several iterations before SMUD and Electrosource were satisfied with the control scheme. The final configuration consists of the original Chloride (CEN) charger with a Mentzer charger installed in parallel. Both chargers are used to perform bulk charging. The CEN charger shuts off when the average cell voltage is 2.375 (module voltage of 14.25 volts), and the Mentzer completes the finishing charge under the control of the Badicheq.

d. Lessons Learned

The Horizon battery test project produced a great deal of insight regarding integration of the batteries into an electric vehicle. This includes everything from connectors and cables to charge management. These considerations are summarized in **Appendix J**.

Not all vehicle installations will face the same design issues to maximize battery pack performance (or energy storage capacity), but in general the following guidelines apply:

- i. Radsok 10.3mm connectors, sized for 2/0 cable, available from KonneKtech (810-294-7400), work extremely well with the Horizon battery in a variety of installation configurations. To minimize side loads on the battery posts, the cables should be fabricated using a fixture to position the connectors as they will be used in the pack. Prior to crimping connector ends onto cable, charge management system connections to terminals should be considered as CMS leads can be crimped with the main power leads in the same barrel.

Charge Cycle Battery Pack Measurements
 <D037 5 253.CTY> (Pickup I)

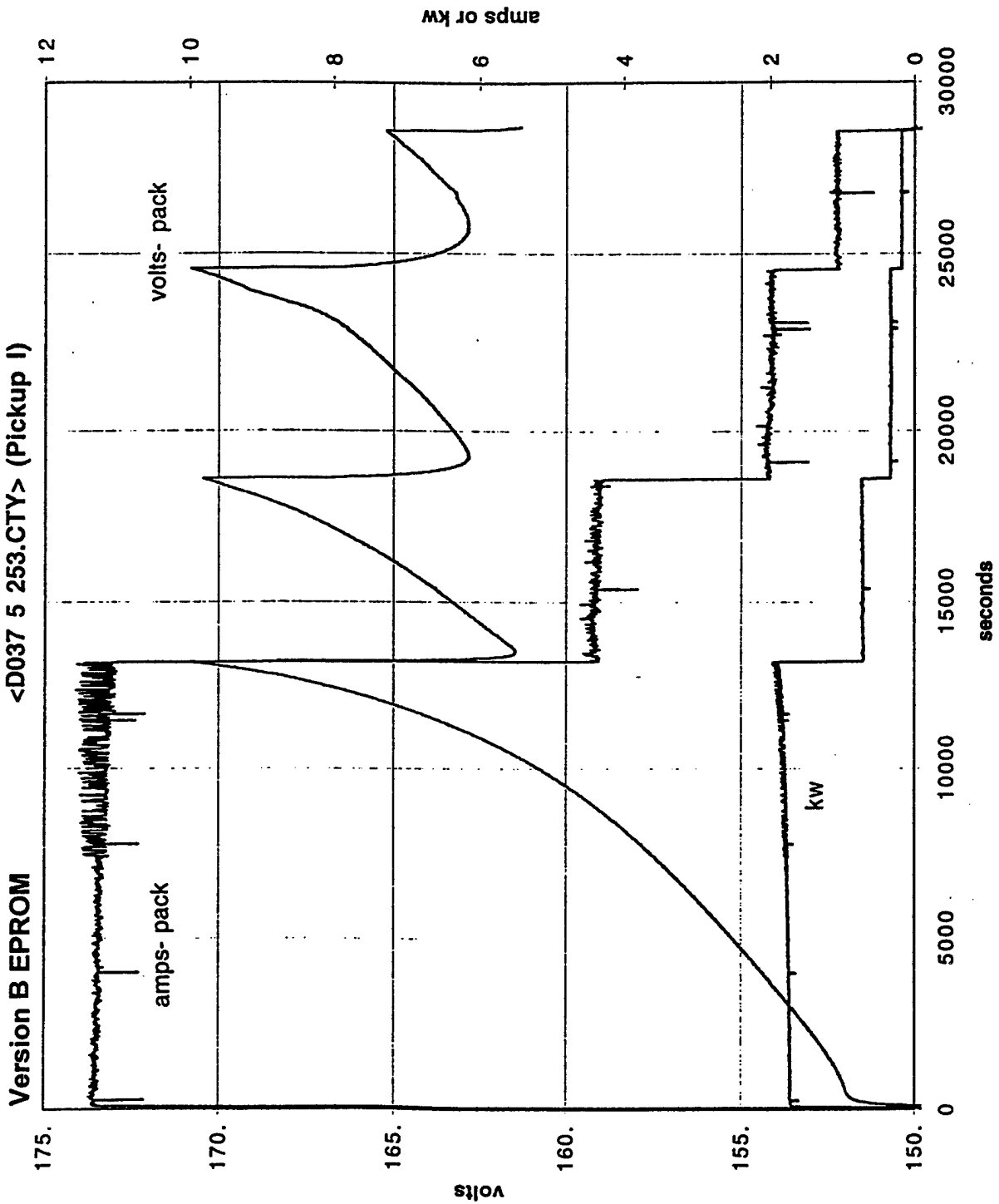

Figure 2. Example Vehicle Charge Cycle Using the Version "B" Charge Algorithm

ii. Battery enclosures are advised for firm positioning of batteries. A flat surface is recommended for the surface on which the batteries will rest. The enclosure should leave approximately one inch of clearance from the battery ends to allow space for cable connectors.

iii. Spacing of batteries for ease of assembly and removal should be considered. Air circulation is accommodated more easily with gaps between modules, however, each module must be secure to prevent battery shifting during use.

iv. The batteries may be layered if needed to fit the available envelope. If the upper layer is not physically supported above the bottom layer, spacer strips at 6 inch intervals along the length of the modules should be used between layers. The spacing is necessary to spread the load of the top battery layer and to provide for air flow between layers.

v. For minimization of thermal gradients and to prevent hydrogen gas buildup, ventilation of the battery enclosure is recommended. No gassing from the Horizon batteries will normally occur, but there is a potential for release of small amounts. A fan capable of one air change every ten minutes, operating during the charge cycle (i.e. when the vehicle is plugged in), should be adequate.

vi. Use of the Badicheq charge management system, available from Drake Associates (516-666-1354), or a comparable charge management system, is strongly recommended. Electrosource will not warranty the Horizon battery unless it is used with a CMS.

vii. The recommended initial charging current of Horizon model 12N95 batteries is 38 amps. A multistep charge profile should be used that reduces the current by one half when all modules have reached 14.25 volts with no modules over 15.5 volts. Each subsequent step down in current is half the previous phase. The finishing/maintenance charge level is one amp. If a multistep charge profile is not available, a constant current/constant voltage/constant current charge profile is recommended.

7. SUMMARY AND CONCLUSIONS

The Advanced Lead Acid Battery Development Project substantially extended the state of the art in valve regulated, or sealed, lead acid battery design. The Horizon® family of batteries, developed by Electrosorce, Inc., demonstrated a specific energy approaching 50 Whr/kg, with very low internal resistance and high Coulombic efficiency when compared to other sealed lead acid batteries.

The Horizon® model 12N95 (12 volt, 95 amp-hour) battery was incorporated into 7 electric vehicles in the SMUD/McClellan fleet. These vehicles, which included a passenger sedan, light-duty pickups, and commuter vans, were put into a range of service. Initial battery performance problems, including high self-discharge and separator plate shorts, were overcome via manufacturing process improvements. Battery pack charging effectiveness was improved over the project period through incorporation of the Badicheq charge management system and use of an improved charge algorithm.

A summary of the field test vehicle status as of the project completion is provided in Table 7-1. A total of 21,915 miles were driven and over 1000 charge cycles demonstrated on the test vehicles. 276 model 12N95 batteries were used during the program. On the seven test vehicles, there were 8 individual battery failures during service and entire battery packs were replaced 6 times. The maximum number of charge cycles achieved on a single battery pack (with no module replacements) was 173.

There were many product improvements and vehicle integration lessons learned during this project that will extend the future life of Horizon® batteries and battery packs. During the last six months of the project, there were very few failures, and it is anticipated that a pack cycle life of hundreds of cycles will be achieved in the very near future.

The Horizon® battery is extremely suitable as a low cost solution for light duty electric vehicles, and provides a useful range that more than meets the requirements of commuter and other fleet vehicles.

Table 7-1. Horizon Battery Field Test Results

Vehicle	Initial Installation	Pack Replaced	Initial Pack Performance	Pack Replaced	Second Pack Performance	Current Status	Pack Performance
McClellan Solectria							
Serial #s	300 + 400	4500 + 4900	300 + 400	6700	4500 + 4900	6700	6700
Date	8/13/94	8/11/95	1 year	1/3/96	5 months	11/9/96	ongoing
Odometer (mi.)	1946.8	3621	1674.2	4551	930	6170	1619
Badicheq Cycle	12	139	127	216	77	396	180
Horlacher Pickup I							
Serial #s	400	2 modules replaced	2 modules 400's	5900 - 6200	10 modules 400's	5900-6200	5900-6200
Date	9/28/94	8/3/95	10 months	11/9/95	1 year	11/9/96	ongoing
Odometer (km)*	1594	3740	2146	4124	2530	7154	3030
Badicheq Cycle	1	142	141	237	236	456	219
Horlacher Pickup II							
Serial #s	3400	6100	3400	6700-6800	6100	6700-6800	6700-6800
Date	4/28/95	11/8/95	5 months	8/27/96	8 months	11/9/96	ongoing
Odometer (km)*	0	2120	2120	3682	1562	down for mods	
Badicheq Cycle	0	60	60	332	272		
Horlacher Sport							
Serial #s	3700 + 4500	6 - 3700's replaced	6 - 3700 modules	4500+5200	4500 + 5200	4500+5200	4500+5200
Date	8/3/96	8/21/95	0.5	1/7/96	4 months	1/18/96	ongoing
Odometer (km)*	22033			24201	2168	down for mods	
Badicheq Cycle	1			16	15	175	159
G-Van #686							
Serial #s	3700-3800	6000-6200	3700 - 3800	6000-6200	6000 - 6200		
Date	9/15/95	12/27/95	2 months	11/8/96	10 months	low capacity	pack needs replacement
Odometer	12939	12989	50	16509	3520		
Badicheq Cycle	6	6	6	353	347		
G-Van #684							
Serial #s	3700 + 3800	3700-3800	3700 - 3800				
Date	3/6/96	11/8/96	8 months			low capacity	pack needs replacement
Odometer	15045	15935	890				
Badicheq Cycle	12	107	95				
G-Van #685							
Serial #s	6000-6600	6000-6600	6000-6600				
Date	5/2/96	11/8/96	6 months			low capacity	pack needs replacement
Odometer	14067	15889	1822				
Badicheq Cycle	0	209	209				
*All results have been converted to miles							

APPENDIX A

**BATTERY PACK
TESTING REPORT**

Prepared By:

Institute of Transportation Studies
University of California at Davis

Report to the Sacramento Municipal Utility District

Ruth MacDougal
Tele: (916) 732-6625
Fax: (916) 732-6839

Progress Report No. 1
March 31, 1995

Battery Pack Testing

David H. Swan Principal Investigator
Blake Dickinson Graduate Student
Institute of Transportation Studies
University of California at Davis

Table of Contents

1. Introduction	3
2. Horizon Reference Battery	4
<i>Charging Methods</i>	5
<i>Test Results</i>	7
<i>Constant Current Performance</i>	7
<i>Constant Power Performance</i>	8
<i>Temperature Effects</i>	9
<i>Self Discharge Rate</i>	11
<i>Simulated Driving Cycles</i>	12
3. Solectria Force Pack Performance	14
<i>Measurement Methodology</i>	14
<i>Pack Performance in Series</i>	15
<i>Pack Performance in Parallel</i>	18
4. Battery Group Performance	20
5. Conclusions and Recommendations	24
<i>Recommendations</i>	24
6. Attachments	25
7. References	26

List of Tables

<i>Table 1 Reference Battery Cycle History</i>	4
<i>Table 2 Comparison of Specifications and Performance for Seal Lead-Acid Batteries.</i>	7
<i>Table 3 Cold Test Results.</i>	11
<i>Table 4 Self Discharge Results.</i>	12
<i>Table 5 Solectria Force Module Replacements</i>	19

List of Figures

<i>Figure 1 Reference Battery (#476) Cycle History.</i>	5
<i>Figure 2 Charge Method A.</i>	6
<i>Figure 3 Charge Method B.</i>	7
<i>Figure 4 Peukert Curves: Normalized Capacity Versus Normalized Discharge Rate.</i>	8
<i>Figure 5 Ragone Plot: Shows the effect of Discharge Rate (Specific Power) on the available Energy Capacity (Specific Energy).</i>	9
<i>Figure 6 Ambient and Battery Case Temperature</i>	10
<i>Figure 7 Geo Metro Wiring Modifications</i>	14
<i>Figure 8 Pack and Module Voltage During C/3 Discharge (as Arrived)</i>	16
<i>Figure 9 Pack and Module Voltage During C/3 Discharge (After 4 Modules Were Replaced)</i>	17
<i>Figure 10 Module Group 1 Performance.</i>	21
<i>Figure 11 Module Group 2A & 2B Performance.</i>	21
<i>Figure 12 Module Group 2A Amp Hours Versus Cycles</i>	22
<i>Figure 13 Module # 1901 from Group 2A Temperature History and Capacity as a Function of Time</i>	22
<i>Figure 14 Module Group 2B Amp Hours Versus Cycles</i>	23

In Vehicle Battery Pack Testing

1. Introduction

This report summarizes the activities conducted from December 1994 to March 31, 1995. All activities have been on *Horizon* batteries with a manufacturer's specified amp hour capacity of 94 based on a three hour rate¹. The research work includes extensive testing of a reference battery, a full battery pack in a vehicle, and a group of new batteries in the laboratory. The individual activities described in this report are briefly described in the following subsections.

A) *Horizon* Reference Battery

Utilizing a selected *Horizon* battery, serial number 476, extensive research has been conducted. This work includes performance as a function of discharge rate (constant current and constant power), temperature effects, self discharge rate, DST and number of cycles. Comparison of the performance between the reference battery and other lead acid batteries was made.

B) Solectria Force Pack Performance

The performance of a "pre-production" battery pack in a Solectria Force electric vehicle was measured. The vehicle is part of the McClellan Air Force electric vehicle fleet and is outfitted with *Horizon* batteries and a Badicheq system. The pack performance was measured using as series and a parallel measurement techniques.

C) Battery Group Performance

Using two groups of *Horizon* a "pre-production" batteries the C/3 performance of each individual battery module was measured.

¹ All "C" values used in this report are based on 94 amp hours.

2. *Horizon* Reference Battery

The use of reference battery was to determine the influence of time and cycle history on the performance of the *Horizon* technology. By choosing a particular battery module, and carefully tracking its cycle history, insight into battery performance and expected life was achieved. The battery chosen, (serial number 476) had relatively good performance from the beginning. The following Table 1 and Figure 1 outlines the cycle history of this particular module.

Table 1 Reference Battery Cycle History

Cycle Number	File Name	Charge Method	Discharge Method	Notes
1	HOR1124	A	C/3	
2	HOR1125	A	C/3	
3 to 8	HOR1125A	A	C/20 C/10, C/5, C/3, C/2, C/1	Peukert Curve
9 to 14	HOR1128	A	10, 20, 30, 40, 50, 60 W/kg	Ragone Plot
15 to 17	HOR1129	A	DST, C/3	Dynamic Performance
18 to 21	HOR1202	A	C/3 (Temp)	C75,D23, 2(C23, D23), C75,D75
22 to 23	HOR1206	A	C/3 Self Discharge	0 Hr., 12 Hr., 24 Hr.
24 to 25	HOR1208	A	C/3	
26 to 27	HOR1213	A (Equalization)	C/3	
29 to 31	HOR1214	A	C/3	Highest Measured Amp Hr. 89.5
32 to 37	HOR1216	A	C/20 C/10, C/5, C/3, C/2, C/1	Peukert Curve
Three Month Rest Period				
38 to 52	HOR0305	A	C/3	Capacity Decreasing
53 to 55	HOR0311	A	C/3	Capacity Decreasing
56 to 75	HOR0312	A	C/3	Capacity Decreasing
76 to 103	HOR0317	B	C/3	New Charge Method

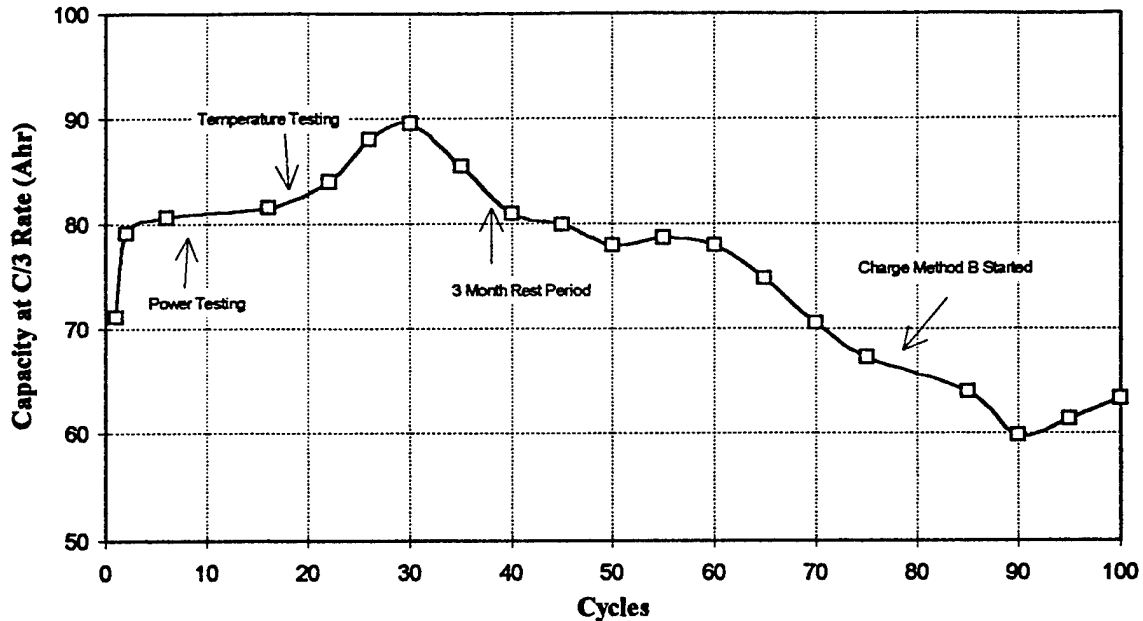

Figure 1 Reference Battery (#476) Cycle History.

In the first 26 cycles the battery underwent testing for constant current, constant power, and the influence of temperature and self discharge. This was followed by cycles that equalized the cells and then a second Peukert curve distribution. The battery module then was rested for three months while other batteries were tested. The rest period was followed by C/3 cycles that utilized both A and B charging methods. A peak performance of 90 amp hours was reached at approximately 30 cycles. Data collected post the 3 month rest period was not substantially different indicating no significant deterioration while the battery was stored in a fully charged condition.

The following 5 subsections describe the reference battery performance to-date. The first subsection describes the charging method, followed by subsections on constant current performance, constant power performance, temperature effects and self discharge rate. Every discharge test was terminated when the battery module reached 10.5 volts under the specific test load.

Charging Methods

Based on recommendations from Electrosources, two methods of charging were employed. The first charge method¹, referred to as method A, uses a CV/CI charge profile. In the first step the battery is charged with a constant current of 40 amps until the temperature compensated clamp voltage is reached (14.25 volts at 25 °C, compensation of 0.0216 Volts/Module/°C, high voltage below 25 °C, lower voltage above 25 °C). When the current has tapered to 2 amps the current is reduced to 1.8 amps and held at this level until the voltage stops rising ($dV/dt = 0$) or a time of two hours is reached.

The second charge method² uses a halving of the current approach (CI). Starting with a current of 38 amps this rate is held until the module voltage reaches the temperature compensated maximum. The current is then cut in half and the procedure repeated (i.e. 38, 19, 9.5, 4.75, 2.375, 1 amps). When the current reaches 1 amp the

current is held at this level for two hours or until the battery voltage stops rising ($dV/dt = 0$).

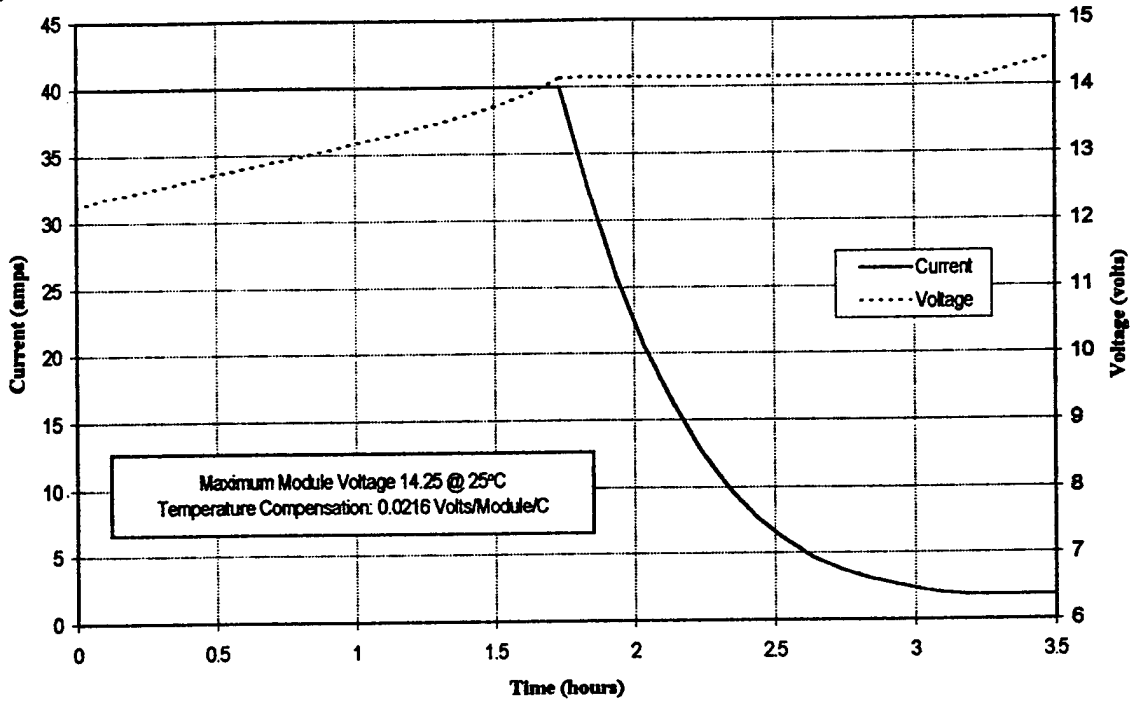

Figure 2 Charge Method A.²

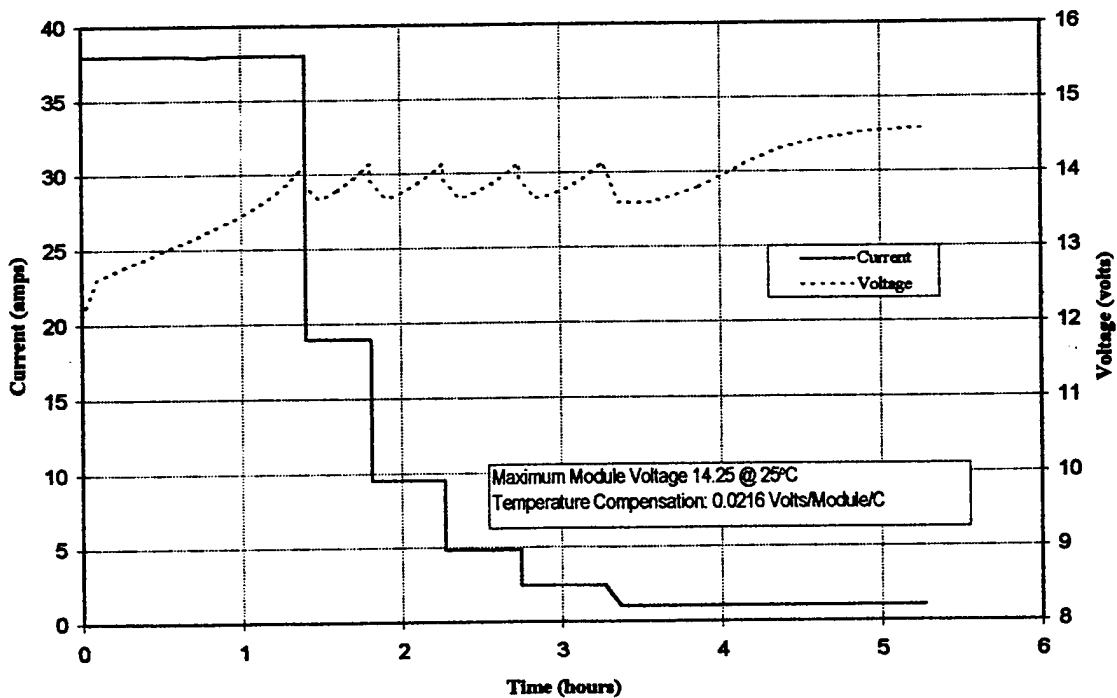

Figure 3 Charge Method B.³

² Charge method provided by Electrosorce, November 1994.

Test Results

Table 2 lists the various battery specifications including cell arrangement, weight, volume, charging method, capacity and efficiency of several sealed lead-acid battery technologies. Figures 4 and 5 graphically show the relative energy capacities and weights of some of the batteries listed in Table 2.

Table 2 Comparison of Specifications and Performance for Seal Lead-Acid Batteries.

Manufacturer	<i>Horizon</i>	Genesis (Hawker)	Delco ³	Sonnenschein ³
Battery Type	Valve Regulated, Electrolyte Starved	Valve Regulated, Electrolyte Starved	Sealed	Valve Regulated Gell Electrolyte
Model	12N95	G12V38AH	M27MF	6V160
No. Cells	6	6	6	3
Weight (kg)	26.75	16	25	31.4
Volume (L)	11.5	5.6	10.5	12.5
Specific Gravity	2.3	2.9	2.4	2.5
Nominal Voltage	12	12	12	6
Nominal Ahr	95	38	105	160
C/3 Capacity	Cycle # 30*			
Ahr	89.2	34.8	54.5	165
Whr	1065	408	635	990
Specific Energy (Wh/kg)	39.8	25.5	25	32
Energy Density (Wh/L)	92.0	72.8	60.5	92
Efficiency				
Energy (%)	88	88	84	89
Coulombic (%)	97	98	97	95
Performance				
DST Cycles Completed	33	17	NA	17
SFUDS Range (km)	102	51	NA	51
Peak Power (W/kg)	162**	125***	105****	127

*Best measured data, **based on module performance, 50% SOC, 30 sec discharge for OCV=12.18, R=7.1 mΩ, I=500, V=8.63, *** based on module performance, 50% SOC, 30 sec discharge for OCV=12.18, R=16.8 mΩ, I=248, V=8.0 **** based on module performance, 50% SOC, 30 sec discharge for OCV=12.18, R=12.8 mΩ, I=327, V=8.0

Constant Current Performance

Constant current performance is measured by continually discharging a battery at a constant current until a predetermined termination voltage is reached. As the battery discharges the voltage falls and the discharge power decreases. The termination voltage used for all constant current reference battery testing was 10.5 volts per module under load (1.75 volts per cell).

³ Charge method provided by Electrosource, Jerry McAlwee, February 1995.

Figure 4 shows the normalized Peukert curves for the *Horizon* reference battery at two points in its cycle history. This normalizing procedure allows batteries of different sizes and chemistries to be easily compared. On the ordinate, the normalized capacity is equal to capacity divided by C-rating (C) of each battery, where the C is the capacity, in amp-hours (Ahr), of the battery. Electrosource rates the *Horizon* battery at 94 amp hours at a C/3 rate. On the abscissa, the normalized discharge rate is equal to actual discharge rate divided by C/1 discharge rate of the battery (94 amps). This figure demonstrates the effect of discharge rate on the coulombic capacity of the *Horizon* battery. A good battery is one which closely attains its rated capacity at all rates of discharge (independent of discharge rate) and would ideally show up on the graph as a horizontal line.

The following figure shows the amp hour capacity of the reference battery for 6 different rates of discharge for cycles 3 to 8 and cycles 32 to 37. In both cycle sequences the C/3 capacity was less than the manufacturer's value of 94 amp hours. The two curves show a small drop in amp hour capacity as the discharge rate increases. In general the capacity of cycles 32 to 37 were higher. In comparison to other flooded lead-acid batteries the *Horizon's* performance was higher. At a normalized discharge rate of 0.1 virtually all batteries attain their rated performance, but at a normalized discharge rate of 1.0 typical lead acid batteries reach only 60% of their capacity³ compared to the *Horizon* at over 80%. This indicates that the *Horizon* battery has a low internal resistance and will maintain its capacity in high power applications.

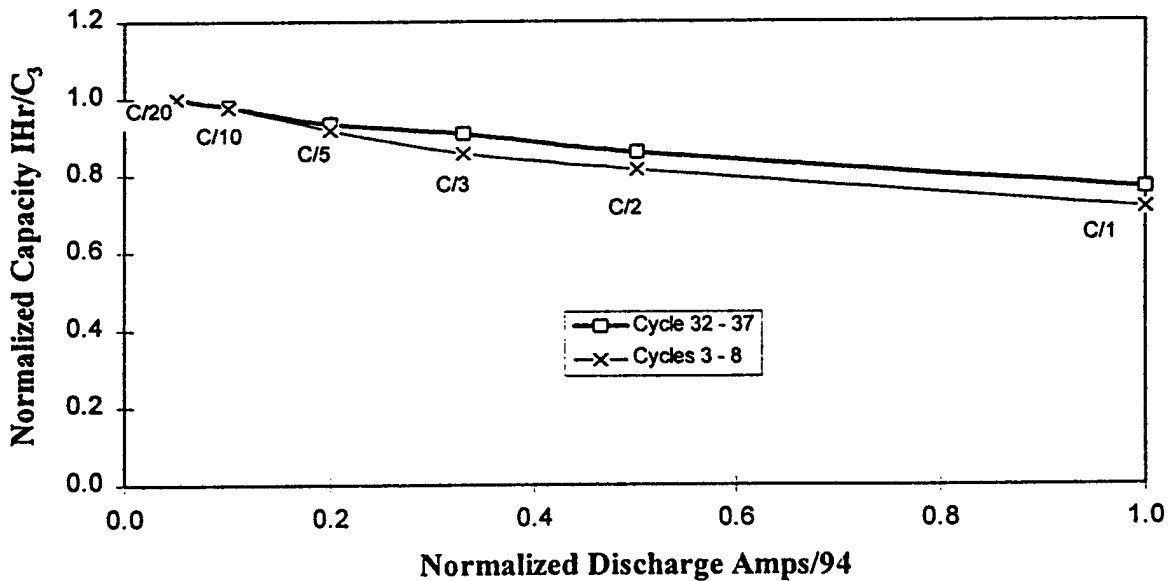

Figure 4 Peukert Curves: Normalized Capacity Versus Normalized Discharge Rate.

Constant Power Performance

Constant power performance is determined by drawing a constant wattage from the battery until a predetermined termination voltage is reached. Over the discharge

period the constant wattage results in a slowly increasing current while the voltage decreases. The termination voltage used for all constant power reference battery testing was the same as the constant current experiments, 10.5 volts per module under load (1.75 volts per cell).

To present the relationship between power rate and capacity a Ragone plot is used. The Ragone plot is a log/linear plot of energy density (Wh/kg) vs power density (W/kg). The ideal battery, as presented on a Ragone plot, would have a high energy density with no dependence on discharge rate. This would be a horizontal line on the Ragone plot.

Figure 5 is a Ragone plot that compares the performance of the *Horizon* reference battery (cycles 9 through 14) to different sealed lead-acid battery technologies. The Delco and Sonnenschein batteries have relatively high energy density at lower rates of discharge, but are seen to be very strongly influenced by discharge rate. The *Horizon* battery has an even better energy density and the slope of the curve is flatter and is seen to be less influenced by higher rates of discharge. As with the constant current data this indicates that the *Horizon* battery has a relatively low internal resistance over the discharge cycle. The positive aspect of this behavior is that the *Horizon* battery will be able to meet a specific high power driving cycle requirements to a deeper depth of discharge than the comparison batteries

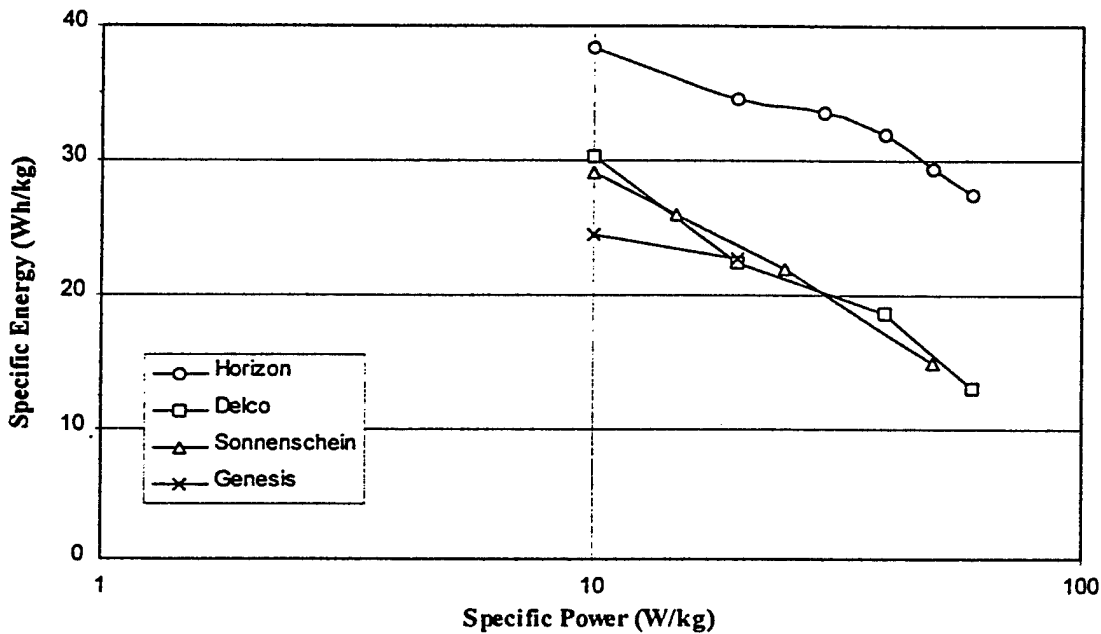

Figure 5 Ragone Plot: Shows the effect of Discharge Rate (Specific Power) on the available Energy Capacity (Specific Energy).

Temperature Effects

Low temperature adversely effects the capacity and power performance of a lead acid battery. The effects of temperature are primarily from

- Reduction in the electromotive force. Typically, the voltage per cell is reduced by 0.25 millivolts per Celsius degree drop in temperature.
- Higher effective internal resistance due to changes in the electrolyte ionic resistance
- Reduction in amp hour capacity due to poor diffusion of electrolyte into the reaction sites. The combination of reduced amp hour capacity and higher internal resistance (voltage losses) leads to lower energy capacity.

To determine the impact of temperature on the *Horizon* battery a series of charge/discharge cycles at different case temperatures were performed. These test were performed by placing the battery in an environmental chamber that used a controller to maintain the ambient temperature surrounding the case between 20 and 26 °F. The battery was supported on small wooden boards to allow the bottom of the battery to be exposed to the ambient air.

The case temperature history of the battery during these tests is shown in Figure 6. The temperature in Figure 6 was the value measured by a J type thermocouple at the top center of the case. Insulation (estimated R value of 0.5 to 1.0 BTU/hr/F°/ft²) was placed over the thermocouple. The insulation over the thermocouple increased the case temperature at that location above the rest of the battery case where there was no insulation, but the temperature inside the battery would likely be even higher.

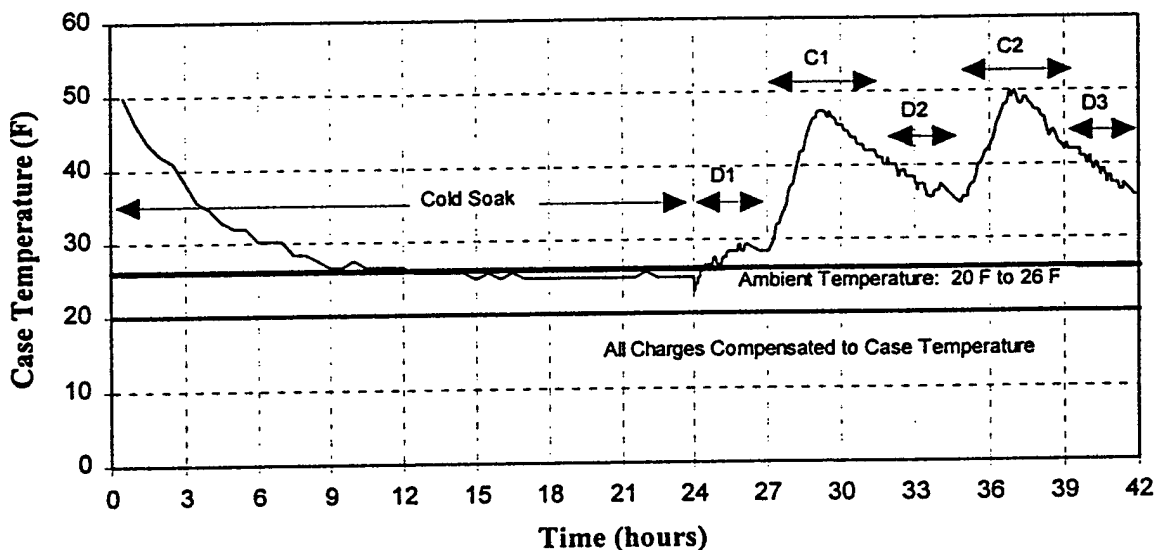

Figure 6 Ambient and Battery Case Temperature

The test procedure to measure the effect of temperature was as follows, the battery was charged normally at 77 °F and then put into the environmental chamber and allowed to cold soak in an ambient temperature of between 20 and 26 °F for 24 hours. Figure 6 shows that the case temperature of the battery was lowered to that of the ambient air temperature.

At the 24 hour mark, the battery was discharged, D1, at a C/3 rate (24 to 27 hours). The thermocouple temperature is seen to rise by approximately 3 °F over this

discharge. The battery was then immediately recharged using temperature compensation based on case temperature, C1, (27 to 31.5 hours). Over this period the case temperature rises and then falls. This is the result of the initial high charge rate causing the temperature to rise, when the current tapers the rate of heat production falls and the temperature declines. During the discharge cycle D2, the temperature falls, during charge C2 the temperature rises again showing a repeatable cyclic pattern. The D1 discharge was truly at the cold soak temperature of less than 26 °F. All subsequent charge discharge cycle held the ambient temperature to less than 26 °F but the effective battery temperature was higher due to losses. The results of these tests are tabulated in Table 3.

Table 3 Cold Test Results.

Cycle Conditions Ambient Air Temperature	Amp Hours (% Loss)* C/3 Discharge	Watt Hours (% Loss*) C/3 Discharge
Cycle # 17 Charge 75 °F C/3 Discharge 75 °F	81.7	965
Charge 75 °F Soak 24 hours @ 23 °F C/3 Discharge 23 °F (D1)	68.6 (-16.0)	795 (-17.6)
Charge 23 °F (C1) no rest C/3 Discharge 23 °F (D2)	75.3 (-7.8)	885 (-11.4)
Charge 23 °F (C2) no rest C/3 Discharge 23 °F (D2)	75.2 (-7.9)	885 (-11.4)

* % Loss as compared to normal C/3 discharge

The cold soak test resulted in an 18.3 % loss in Ahr capacity. This capacity loss also includes the loss due to self discharge (described in the following section). As the battery warmed up due to cycling the capacity loss decreased to around 10%. Thus, if the vehicle is driven and charged continuously or kept in a heated garage, the capacity loss should not exceed 10%, but the vehicle range would be reduced more than 10% because of greater losses in other components on the cold vehicle. The coulombic efficiency did not change as the temperature decreased but energy efficiency did due to higher internal resistance.

Self Discharge Rate

When a charged battery is left inactive over a period of time, self discharge of the battery occurs. Table 4 demonstrates the self-discharge that occurs in the *Horizon* battery when it is left resting for 12 and 24 hours. The battery shows an initial loss in capacity in the first 12 hours of stand time, but there is virtually no further capacity loss between 12 and 24 hours.

Table 4 Self Discharge Results.

Cycle Condition	Ahr (Loss in %)*	% Loss* (Whr)
Charge 75 F 12 hour rest C/3 Discharge 75 F	-81.6 (2.9)	-0.95 (3.4)
Charge 75 F 24 hour rest C/3 Discharge 75 F	-80.9 (3.7)	-0.94 (4.1)
Charge 75 F C/3 Discharge 75 F	-84.0	-0.99

* % Loss as compared to normal C/3 discharge

Normal Variance in C/3 values?

Simulated Driving Cycles

The purpose of this test is to predict the range of a specific electric vehicle using the test battery, on a particular driving cycle. There are several driving cycles that are regularly used to test the performance of electric vehicles, but one, the SFUDS, seems to be the most widely used. The SFUDS is based upon the federal urban driving schedule, which is the cycle on which all Internal Combustion (IC) cars derive their city fuel consumption. Figure 1 shows the SFUDS power vs. time profile. The SFUDS power spectra is derived from the U.S. Department of Energy's "Improved" Dual-Shaft Electric Propulsion (IDSEP) vehicle [2].

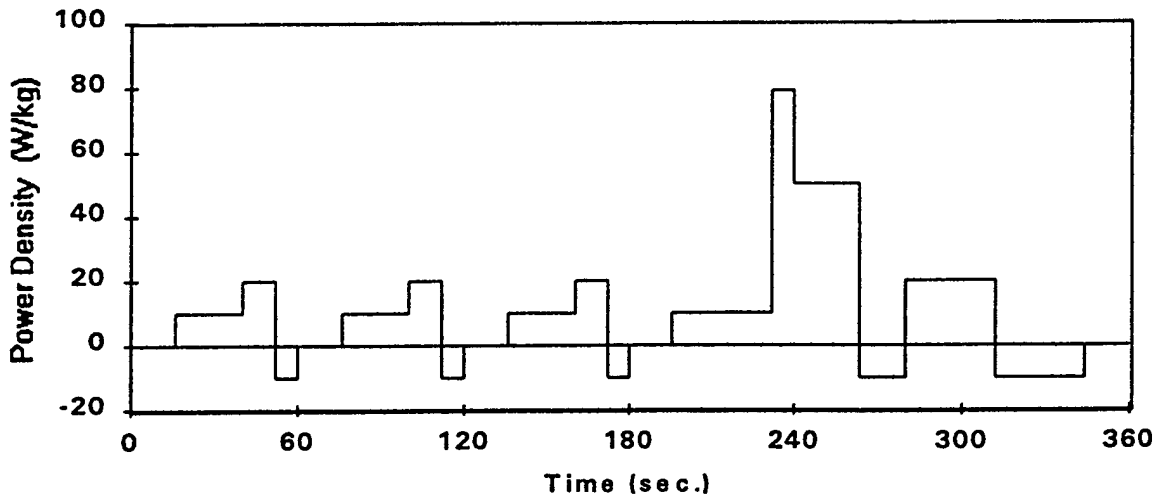

The IDSEP vehicle characteristics are defined below:

- Curb Weight 2397 kg
- Battery System Weight 695 kg
- Aerodynamic Drag Coefficient 0.37
- Rolling Resistance Coefficient 0.008
- Frontal Area 2.97 m²

Each 360 second segment of the SFUDS battery test cycle corresponds to 3.1 Km of urban driving of an electric vehicle. Hence the range of the vehicle with the battery being tested would be 3.1 Km times the number of 360 second segments of test. The test is ended when the battery can no longer provide 50 W/kg as prescribed by the SFUDS procedure.

The results of these tests are tabulated in Table 2. The *Horizon* battery shows a far greater range than either the Sonnenschien or Genesis batteries. This is due to the higher energy density and the lower internal resistance of the *Horizon* batteries. A higher peak power capability of the *Horizon* batteries allow them to complete more SFUDS cycles before they cannot meet the 50 W/kg minimum power requirement.

3. Solectria Force Pack Performance

The Solectria Force from McClellan Air Force Base was instrumented and operated in several discharge/charge cycles. These cycles included charging and discharging the pack in both series and parallel strings. Based on these results four battery modules were determined to be of low amp hour capacity and were replaced.

Measurement Methodology

The objective of measuring the Solectria battery pack performance is to quantitatively evaluate the pack conditions and battery charger performance. This can be accomplished by charging and discharging the pack (in a controlled manner), in series, in the vehicle, and monitoring the voltage of each module. When the weakest module voltage drops to a predetermined level the discharge is terminated and the pack is recharged. This provides a snapshot of the pack up to the "limiting" battery module (without any damage to the pack) but does not determine the capacity of the rest of the modules in the pack string.

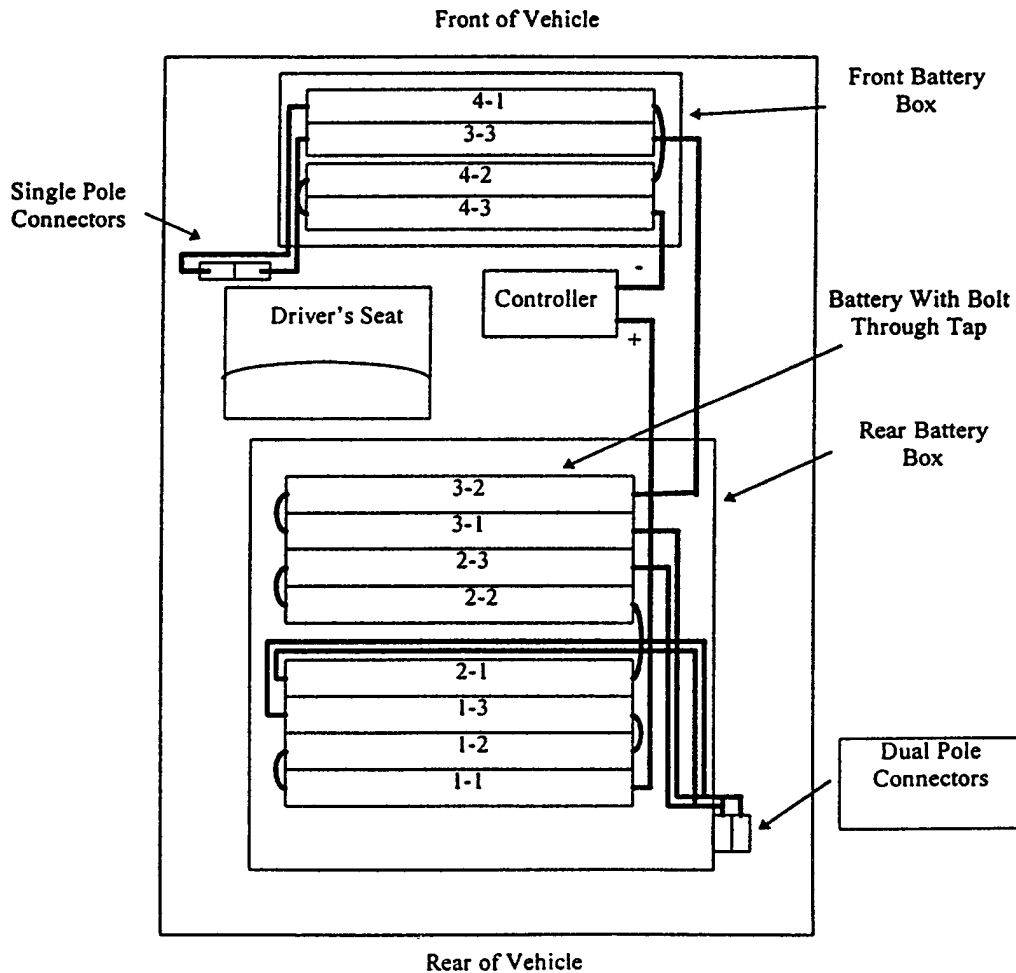

Figure 7 Geo Metro Wiring Modifications

Ideally, to determine the performance of each module, the pack would be disassembled and each module tested individually on battery cycling equipment. Which provides closely controlled charging and discharge profiles. The value of this approach is not only to determine the capacity of each module, but to be able to assess the change in condition of the strong as well as the weak batteries over time. In the series only discharge, the condition of the strong modules or any change they may be experiencing between successive evaluations of the pack is not measured.

Due to time and financial constraints, it was not possible to disassemble the battery pack and test each individual module. However, to obtain as much information as possible, the battery cabling was modified, See Figure 7.. By placing dual pole connectors in the pack, the series string can be quickly converted into four parallel strings of 3 batteries each. These short strings can be directly connected to the cycling equipment and are monitored individually. The cyler charges the strings using the algorithm specified by the manufacturer and can discharge the strings to any programmable cycle. Using this approach, each short string is only limited to its individual weakest module. Although this approach is not ideal, the grouping of short parallel strings approximates individual modules being placed on the cyler. Results of this approach provided data on the relative capacity of each of the parallel strings. The stronger battery modules can be determined without damaging the weaker modules.

Results of testing using this methodology are presented in the following two subsections, Pack Performance in Series, and Pack Performance in Parallel.

Pack Performance in Series

The battery pack was discharged and charged as a complete string monitoring each individual battery module voltages. The charge was accomplished by the on-board charger, the discharge was regulated at a C/3 rate by a computer controlled chopper into a resistance bank. The discharge was terminated when the pack voltage reached 126 volts (10.5 volts per module average)

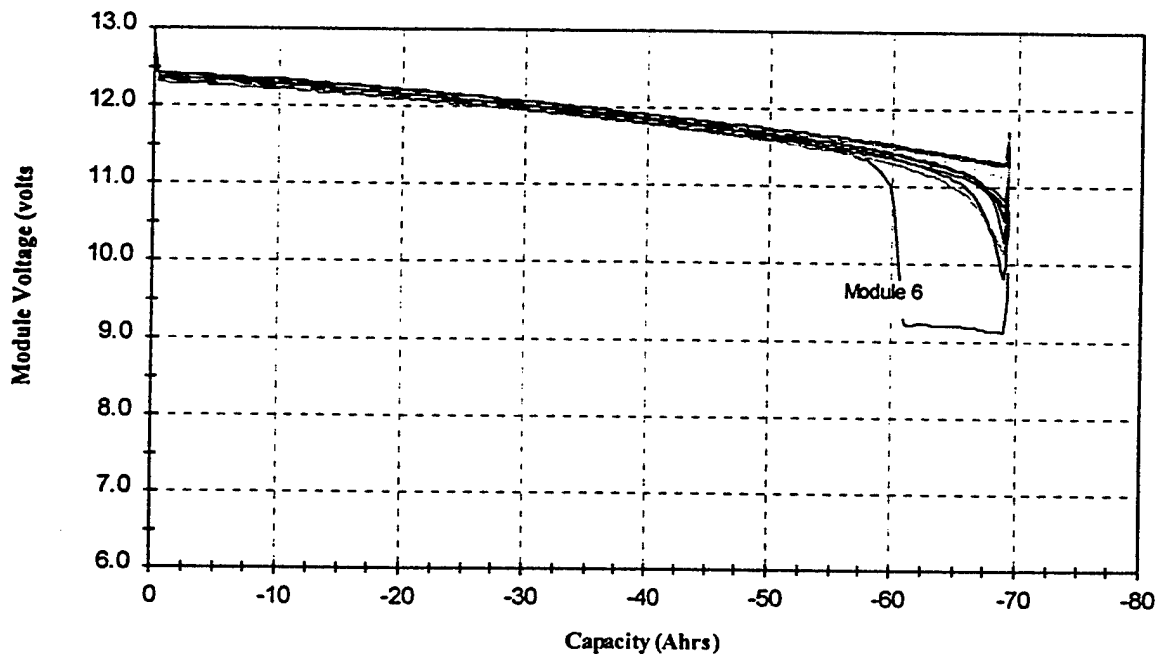
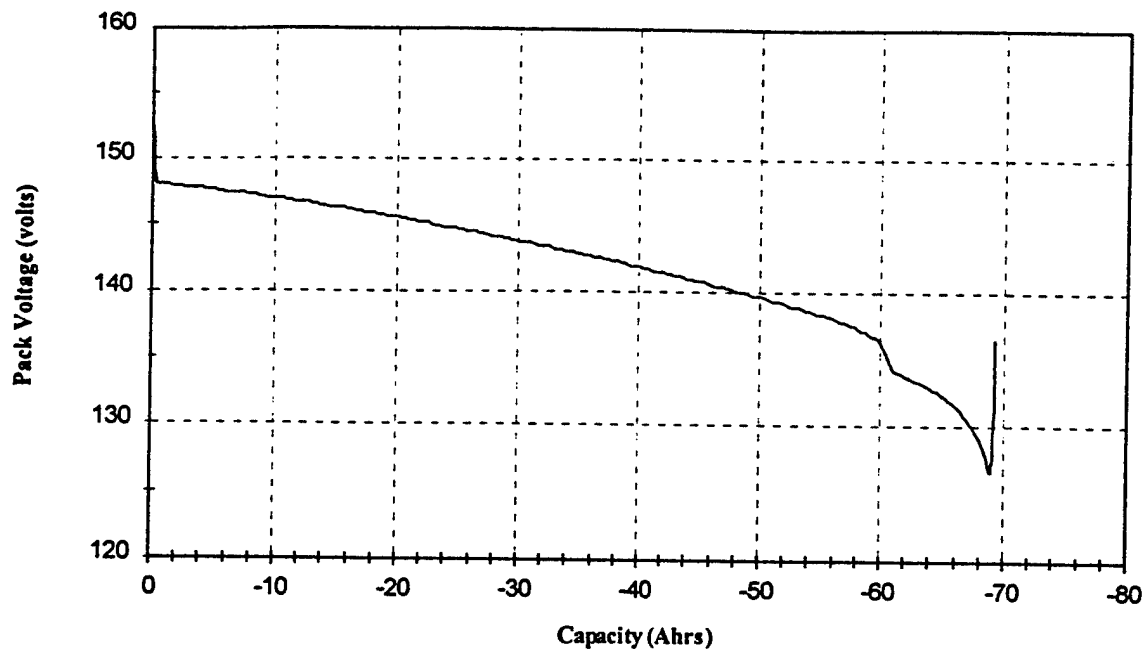
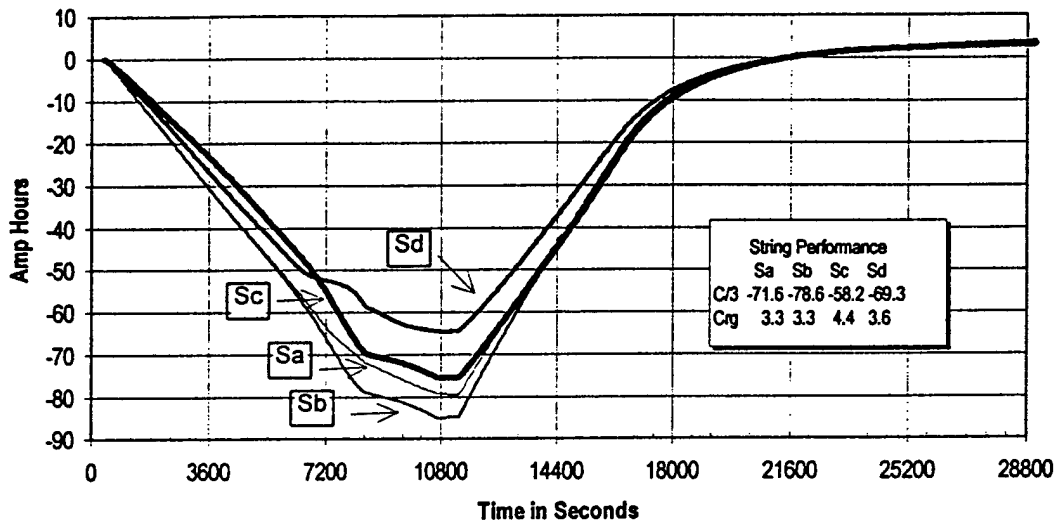

Figure 9 Pack and Module Voltage During C/3 Discharge (After 4 Modules Were Replaced)

Pack Performance in Parallel

Parallel discharge on the cyclor provides the ability to determine performance in small groups thus approximating a single module. Using the wiring configuration as described in the introduction to this chapter the batteries were put in four strings of three models. The batteries were charged using the A charge algorithm based on average module voltage. The discharge was terminated when the strings pack voltage reached 31.5 volts (10.5 volts per module average).



Module Volts

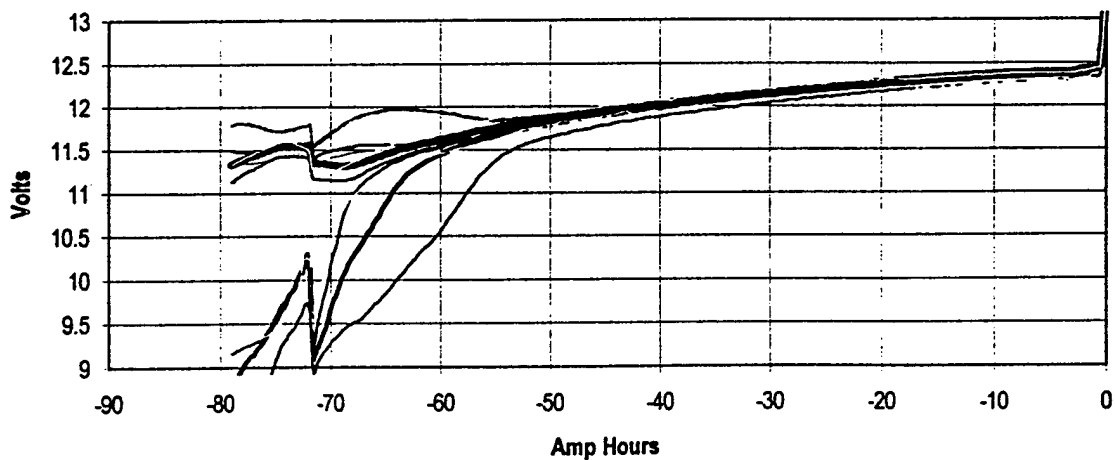

Table 5 Solectria Force Module Replacements

Battery #	Old Module #	New Module #
8	488	1138
12	480	1137
3	325	1014
10	479	1040
3	1014	1160

4. Battery Group Performance

Several groups of *Horizon* 95 Ahr modules were delivered to the EVPSL during the months of January and February 1995. These preproduction battery modules were known to be substandard modules and were sent to determine which ones were good enough to group into a battery pack. The first group of 12 modules arrived on 1/12/95 and a second group of 6 modules arrived on 1/23/95. These modules were cycled between 10 and 15 times before they were returned to SMUD. The peak performance of these modules, at a C/3 discharge rate, are shown in Figure 10. This figure also shows the performance of the reference battery, module # 476 (described earlier in the text), as a comparison. One module arrived with a cracked case (module 1091), and two with a very low initial voltage (modules 1097 and 1149), less than 12 volts. All three of these modules performed very poorly as shown in Figure 10. None of the modules attained their rated capacity but the capacity was particularly low for modules with initial low open circuit voltage. Since low initial voltage seemed to be an indication of a weak module, we decided to record the initial voltage on the modules as they arrived.

A final shipment of 14 modules were delivered on 2/3/95. These were cycled up to 20 times at a C/3 rate to attain best possible performance. The capacities of these modules and some of their initial voltages are shown in Figure 10. Although the initial open circuit voltage does not show a strong correlation to capacity, there is enough of a correlation to investigate it further. At the very least, low voltage modules should be rejected or cycled before using them in vehicles.

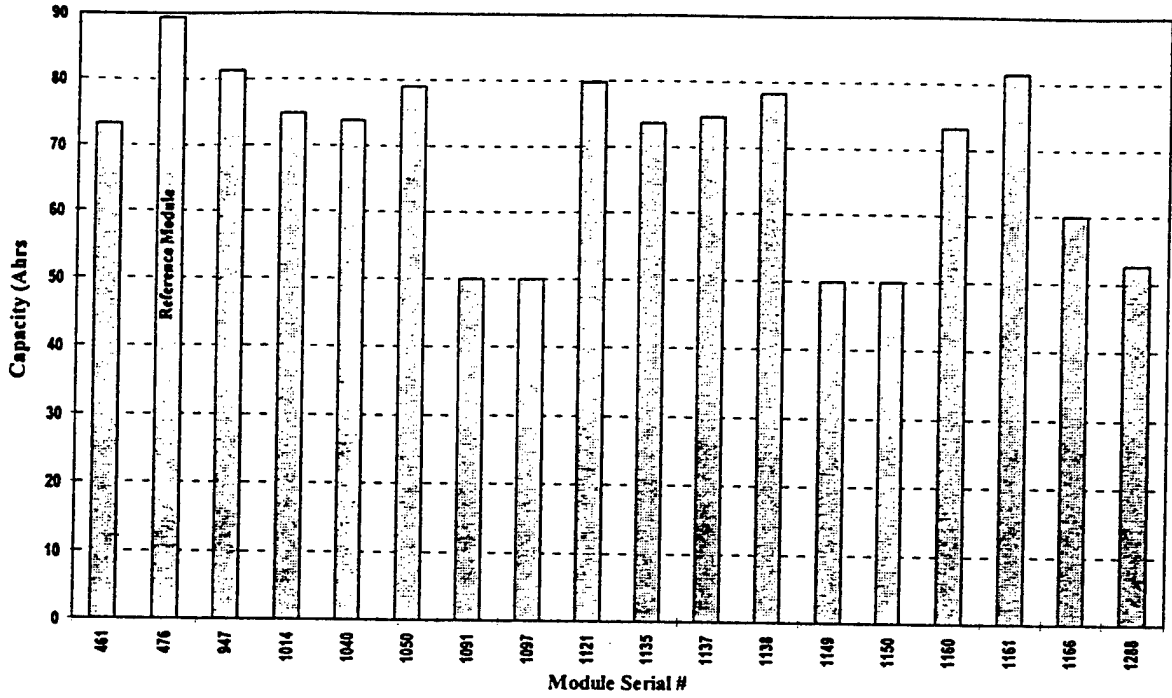

Figure 10 Module Group 1 Performance.

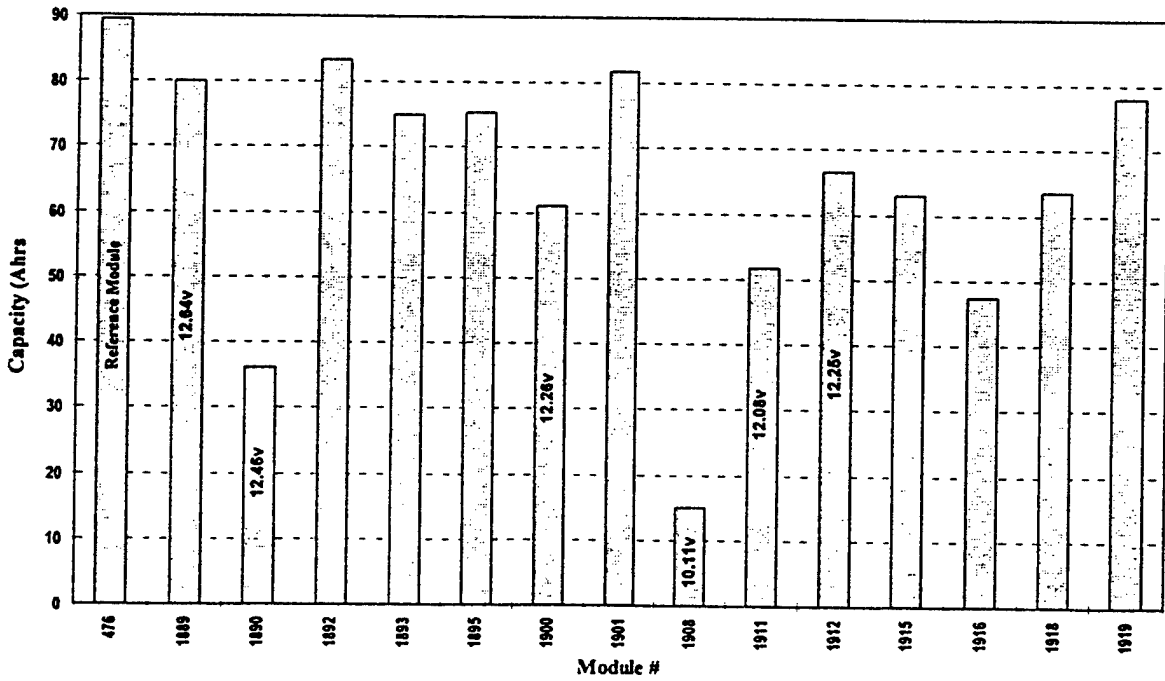

Figure 11 Module Group 2A & 2B Performance.

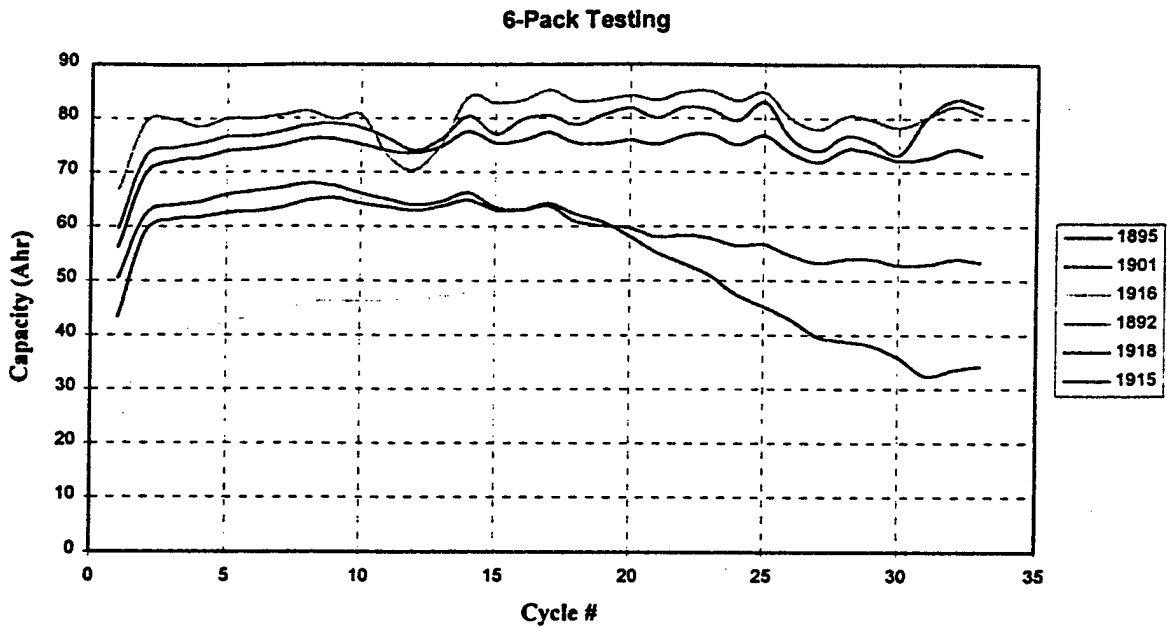

Figure 12 Module Group 2A Amp Hours Versus Cycles

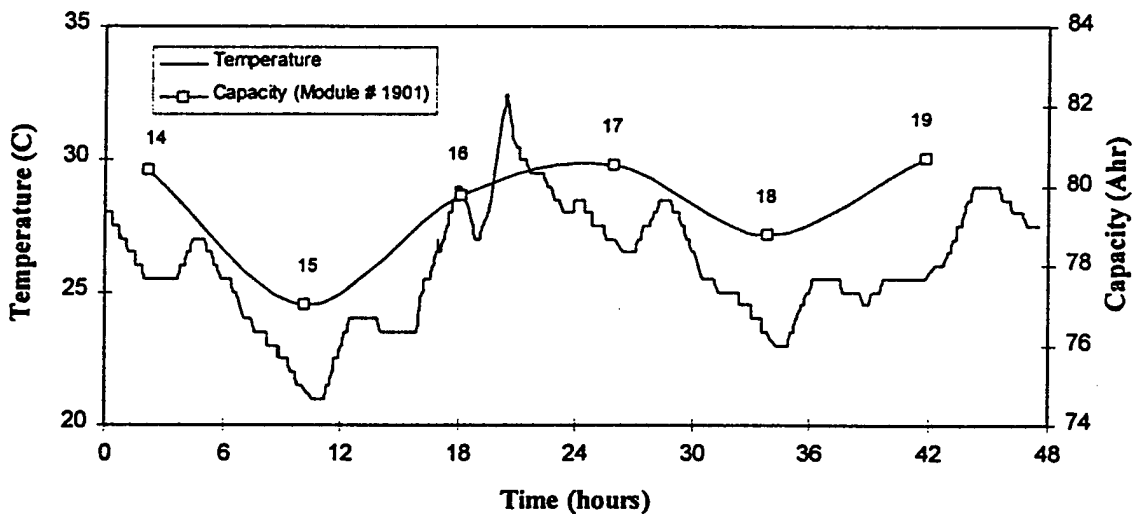

Figure 13 Module # 1901 from Group 2A Temperature History and Capacity as a Function of Time

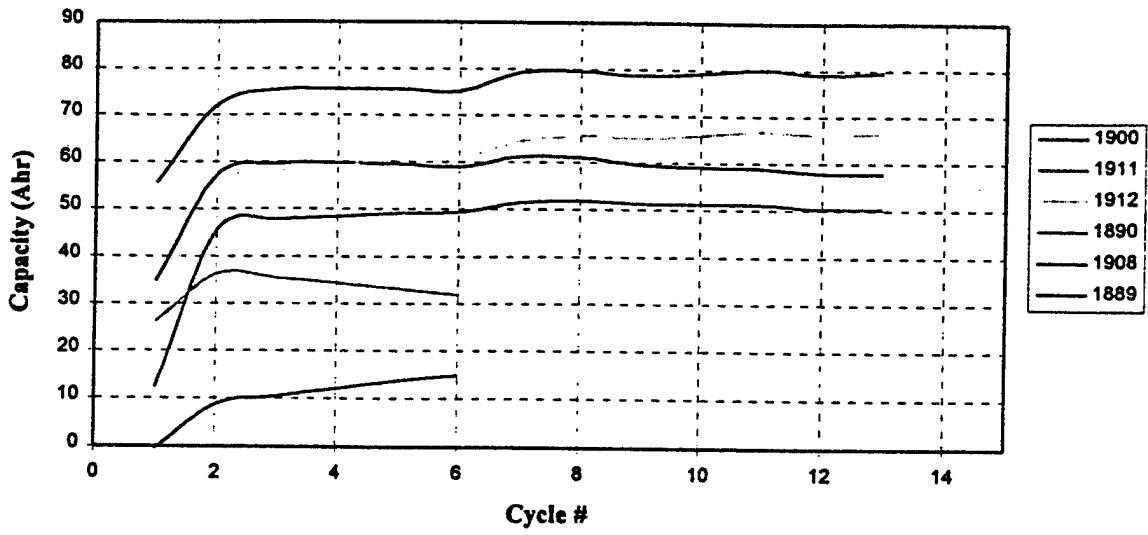

Figure 14 Module Group 2B Amp Hours Versus Cycles

5. Conclusions and Recommendations

Conclusions on the "preproduction" *Horizon* (serial numbers ranging from 325 to 1918) batteries are presented below:

- Amp Hour capacity of all tested modules are below the manufacturer's specifications (94 amp hr). In the case of the reference battery the difference was small (5 %) while for other modules it was much larger. The batteries that performed poorly were generally in serial number range of 1000 to 2000. Electrosorce has stated that due to a change in the formation process the batteries tested in this work were adversely effected and are not representative of early or later modules, see letter in attachments section.
- The *Horizon* battery has a high coulombic efficiency. Even the low capacity batteries had high coulombic efficiencies.
- The reference battery indicated a small rate of self discharge.
- Compared to other sealed lead acid batteries, the *Horizon* reference battery shows a high specific energy.
- Compared to other sealed batteries the *Horizon* reference battery has an extraordinary low internal resistance and flat Ragone Curve. This characteristic is very important in that discharge at a high rate does not significantly reduce energy available. Performance of the reference battery is close to some nickel cadmium batteries.
- The cycle-life of the reference battery was less than expected. Considering an effective 80 amp hour capacity, the 80% of capacity (64 amp hours) was reached at approximately 85 cycles.
- A reduction in temperature reduced amp hour capacity and increased internal resistance.

Recommendations

- The charge methods (A & B) are not the optimum. A new charge method has been provided by Electrosorce (method C) and will be used for all future testing.
- The temperature used for temperature compensation of the clamp voltage should be decreased from 5 C° to 2.5 C°.
- The daily ambient temperature fluctuation in the laboratory should be minimized as it has an influence on battery performance.



Electrosource

Michael G. Semmens
President and
Chief Executive Officer

February 23, 1995

Electrosource, Inc.
3800-B Drossett Drive
Austin, Texas 78744-1131 USA
512.445.0606
Fax 512.445.0583

Ms. Ruth MacDougall
Electric Transport Department
Sacramento Municipal Utility District
P.O. Box 15830
Sacramento, CA 95852-1830

Dear Ms. MacDougall:

Electrosource has experienced some recent production problems in the 12N95 Horizon® Batteries that were purchased by SMUD. In an attempt to improve the rate of throughput in our San Marcos facility, we changed the formation process to include a deep discharge cycle early in the process. Initially the results of this change were very positive. However, we have determined that some batteries were adversely affected by this change and it has been removed from our process.

The Horizon® Batteries that were affected will exhibit a decreasing open circuit voltage. Any batteries that fall below 11 volts in an open circuit mode should be set aside for return to Electrosource. We will replace all batteries with the identified problem at our cost.

We regret any inconvenience that this problem has caused SMUD or its customers and partners. Electrosource is committed to fielding quality batteries to support the emerging electric vehicle market and recognizes the leadership role that SMUD has taken in the EV market. Mr. Chris Morris will be directly responsible to insure that SMUD receives quality product and prompt response to any inquiries. Please feel free to contact him directly at (512)753-6500.

Thank you for your understanding and continued support.

Very truly yours,

Michael G. Semmens
President and
Chief Executive Officer

MGS:jr

cc: Chris Morris

7. References

1. Horizon Charge Profile, Issued March 1994, initial current limited to 40 Amps based on telephone conversation with Jerry McAlwee of Electrosorce.
2. Horizon Battery Handbook, (Draft Copy) January 6, 1995, Page 7.
3. B. E. Dickinson, D. H. Swan and T. R. Lalk, "Comparison of Advanced Battery Technologies for Electric Vehicles", Future Transportation Technology Conference, San Antonio, Texas, August 9-12, 1993, SAE Paper No. 931789.
4. DeLuca W. H. et al., "Performance and Life Evaluation of Advanced Battery Technologies for Electric Vehicle Applications", SAE paper No. 911634.

Report to the Sacramento Municipal Utility District

Ruth MacDougal
Tele: (916) 732-6625
Fax: (916) 732-6839

Progress Report No. 2
June 30, 1995

Battery Pack Testing

David H. Swan Principal Investigator
Blake Dickinson Graduate Student
Institute of Transportation Studies
University of California at Davis

Table of Contents

1. Introduction	3
2. Horizon Battery Performance	4
<i>Charging Methods</i>	4
<i>Constant Current Performance</i>	5
<i>Battery Comparison</i>	7
3. Conclusions and Recommendations	9
<i>Recommendations</i>	9

List of Tables

<i>Table 1 Comparison of Specifications and Performance for Seal Lead-Acid Batteries.</i>	<u>7</u>
---	----------

List of Figures

<i>Figure 1 Charge Method B.</i>	<u>4</u>
<i>Figure 2 Horizon Battery C_{7/3} Performance at Cycle 9.</i>	<u>5</u>
<i>Figure 3 Module Group A Amp Hours Versus Cycles</i>	<u>6</u>
<i>Figure 4 Module Groups B Amp Hours Versus Cycles</i>	<u>6</u>

1. Introduction

This report summarizes the activities conducted from April 1995 to June 30, 1995. All activities have been on *Horizon* batteries.

- A. An analysis of battery pack performance has been performed on batteries tested in the January to March 1995 quarter. This analysis, which did not use the *Horizon* battery by name, appears in SAE Paper number 951949 contained in the attachments section. Permission by SMUD and Electrosource was obtained to use the data with out specifically naming the *Horizon* battery.
- B. A new group of 12 *Horizon* batteries (serial numbers varying between 3635 to 3738) were tested on a constant current, $C_3/3$, discharge rate¹. The performance of each individual battery module has been measured and the results are given in the following figures and tables. A comparison is made between the previous best *Horizon* battery serial number 476 (reference battery) and the new best battery serial number 3668.

¹ All "C" values used in this report are based on the manufacture rating of 94 amp hours in 3 hours at a constant current discharge of 31.3 amps terminating at an average cell voltage of 1.75 volts per cell. The term $C_3 = 94$ indicates the nominal amp hour capacity value for 3 hours. This capacity is used at other rates i.e. $C_3/2 = 47$, at this rate the battery would not be expected to last 2 hours due to larger electrolyte concentration gradients within the electrode pores.

2. Horizon Battery Performance

A group of 12 *Horizon* 95 amp hour modules were delivered to the EVPSL in June. These modules were separated into two groups of six modules and were cycled on a constant current $C_3/3 = 31.3$ discharge to quantify performance. The following text describes the charging method used and the constant current performance of the 12 modules.

Charging Methods

Based on recommendations from Electrosorce, the charge method¹ uses a halving of the current approach (CI). Starting with a current of 38 amps this rate is held until the module voltage reaches the temperature compensated maximum. The current is then cut in half and the procedure repeated (i.e. 38, 19, 9.5, 4.75, 2.375, 1 amps). When the current reaches 1 amp the current is held at this level for two hours or until the battery voltage stops rising ($dV/dt = 0$). The following figure describes the charge method, the name charge method "B" is to distinguish it from method A as described in the March quarterly report.

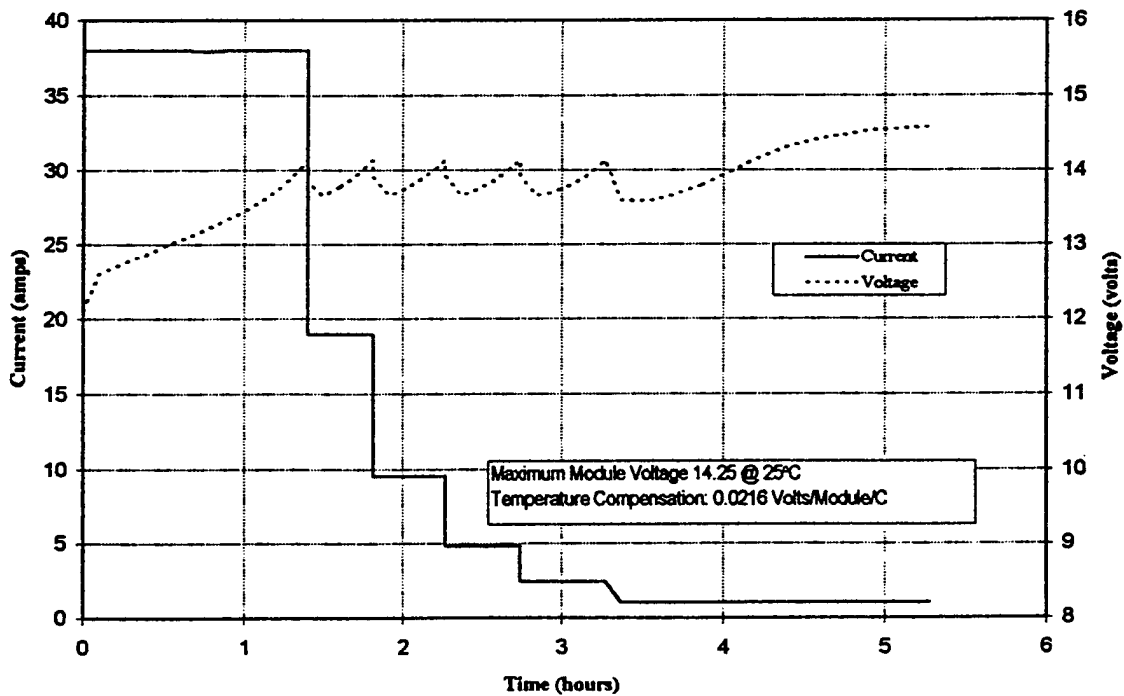

Figure 1 Charge Method B.²

² Charge method provided by Electrosorce, Jerry McAlwce, February 1995.

Constant Current Performance

Constant current performance is measured by continually discharging a battery at a constant current until a predetermined termination voltage is reached. As the battery discharges the voltage falls and the discharge power decreases. The termination voltage used for all constant current battery testing was 10.5 volts per module under load (1.75 volts per cell).

The performance of the tested modules, at a $C_3/3$ discharge rate on the 9th charge discharge cycle, are shown in Figure 2. This figure also shows the performance of the reference battery, module # 476 (described in the March 1995 quarterly report), at cycle 30 as a comparison. Cycle 30 represents the best performance of the reference battery. It is interesting to note that at cycle 9 of the reference battery the $C_3/3$ discharge capacity was only 81 amp hours, significantly less than all twelve of the new modules. However a direct comparison of capacity as a function of cycles can not be made as the number of cycles in formation are unknown. After each serial number is a letter referring to the respective test group A or B. On average test group B cycled at a higher temperature than A due to high ambient EVPSL temperatures.

All modules arrived with initial open circuit voltages between 12.69 and 12.75.

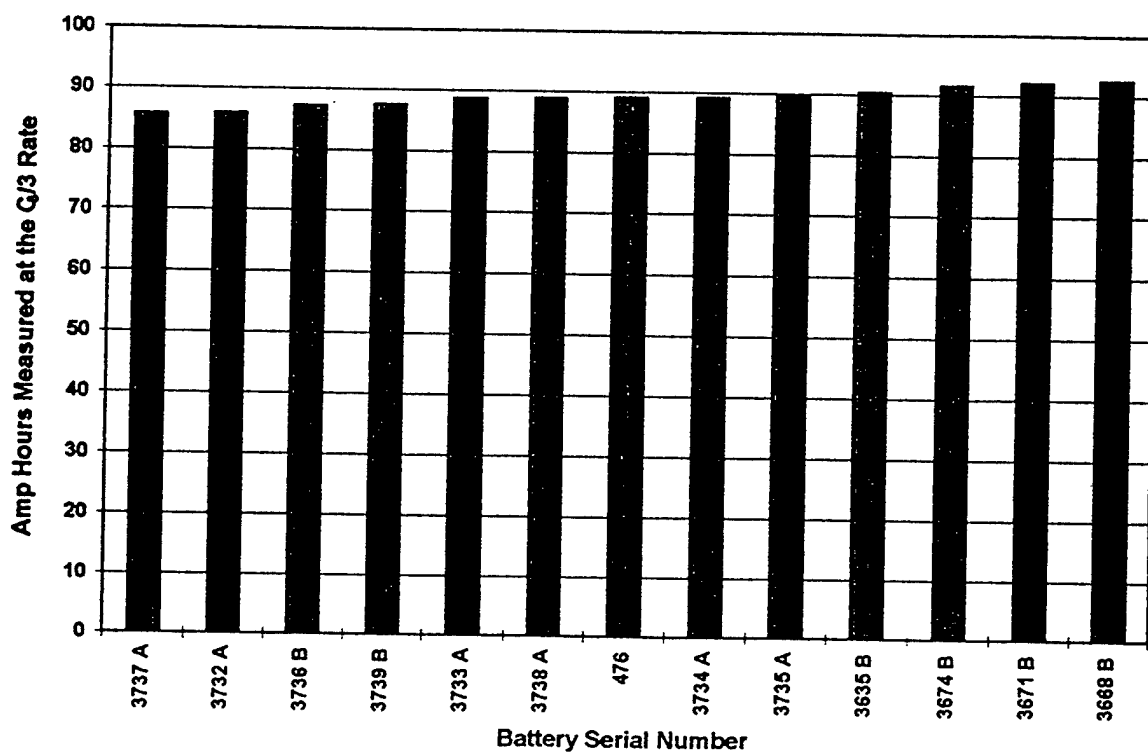

Figure 2 Horizon Battery $C_3/3$ Performance at Cycle 9.

The performance of the individual modules as a function of discharge-charge cycle is presented in figures 3 and 4. The grouping resulted from the simple inability to test more than 6 modules at a time on the EVPSL equipment.

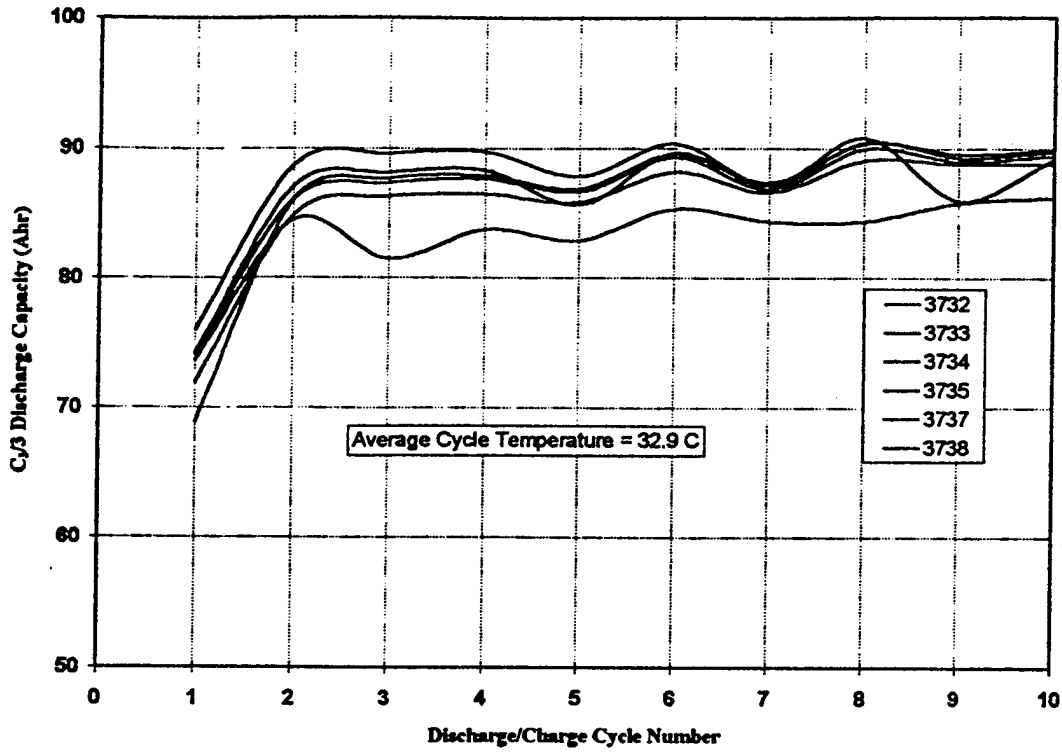

Figure 3 Module Group A Amp Hours Versus Cycles

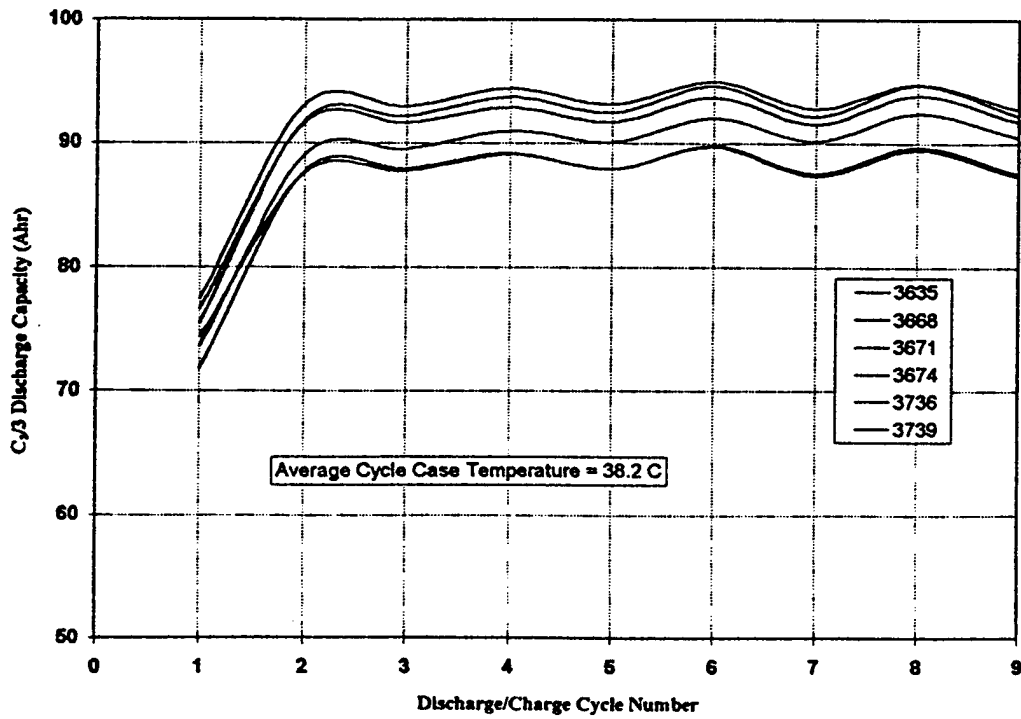

Figure 4 Module Groups B Amp Hours Versus Cycles

The continues cycling for each group occurred over two 4 day periods that had different average ambient temperatures as noted in the respective figures. The batteries operating in the higher ambient temperature, group B, had a higher average C₃/3 capacity then group A.

The first discharge-charge cycle in both group A and B is approximately 15 amp hours lower then subsequent cycles. All batteries had the low capacity first cycle and it is probably the result of self discharge during delivery and storage.

The "wave" in the capacity data as a function of cycles is due to changes in EVPSL ambient temperature as reported in quarterly report 1. The typical 24 hour ambient temperature swing is 6 C°, with a change in C₃/3 capacity of 2 to 3 amp hours.

Battery Comparison

Table 1 lists the battery specifications for the *Horizon* reference battery, Horizon serial # 3668 (best battery, best performance) a Hawker battery used by US Electricar S10 trucks and a Sonnenschein battery used in various electric vehicle conversions. The table lists cell arrangement, weight, volume, amp hour capacity and efficiency.

Table 1 Comparison of Specifications and Performance for Seal Lead-Acid Batteries.

Manufacturer	<i>Horizon</i> Serial # 476 (Reference)	<i>Horizon</i> Serial # 3668	Genesis (Hawker)	Sonnenschein ²
Battery Type	Valve Regulated, Electrolyte Starved	Valve Regulated, Electrolyte Starved	Valve Regulated, Electrolyte Starved	Valve Regulated Gell Electrolyte
Model	12N95	12N95	G12V38AH	6V160
No. Cells	6	6	6	3
Weight (kg)	26.75	26.5	16	31.4
Volume (L)	11.5	11.5	5.6	12.5
Specific Gravity	2.3	2.3	2.9	2.5
Nominal Voltage	12	12	12	6
Nominal amp hours C ₃	95	95	32.3	160
Measured C₃/3 Capacity	Cycle # 30*	Cycle # 6*	Cycle # ≈ 10*	
Case Temperature	27 °C	38 °C	31.5 °C	
Amp hours	89.2	95	34.8**	165
Watt hours	1065	1125	408	990
Specific Energy (Wh/kg)	39.8	42.5	25.5	32
Energy Density (Wh/L)	92.0	97.8	72.8	92
Efficiency				
Energy (%)	88	88	88	89
Coulombic (%)	97	98	98	95

* Cycle numbers at the EVPSL, the total number of battery module cycles are unknown due to differences in the formation process.

** Discharged at the C₁₀/3 rate = 38/3 amps.

In comparing the two *Horizon* batteries it should be noted that serial # 3668 was cycled at a case temperature substantially higher then serial # 476 (difference as a result of the seasonal swing, in the EVPSL temperature). The higher temperature enhances the performance of serial # 3668 by approximately 0.5 amp hour per C° and 6 Watt hours per

C°. (based on results presented in quarterly report 1 and observation of the Horizon battery during EVPSL testing). The performance enhancement with temperature will probably scale with plate size and number for the *Horizon* design. As a result, the capacity difference between serial numbers 476 and 3668, when compensated for temperature, is small. Considering a difference in case temperature of 11 C° higher, serial number 476 would have approximately $89.2 + 5.5 = 94.7$ amp hours and $1065 + 66 = 1131$ Watt hours. These results are virtually identical to serial number 3668.

In comparison, to the Hawker and Sonnenschein products, the *Horizon* batteries have a high specific energy. ~~The energy density is higher than the gates battery and comparable to the Sonnenschein.~~ Energy and coulombic efficiency is high for all of the batteries. What the table does not address is the issues of life and resilience of performance in an actual electric vehicle application. To determine this will require that the now "characterized" *Horizon* batteries be placed in a high use electric vehicle and be re-characterized as a pack. Subsequently the pack should be brought to the EVPSL monthly for series/parallel performance characterization.

3. Conclusions and Recommendations

Specific conclusions on the *Horizon* batteries (serial numbers ranging from 3635 to 3738) are presented in the following bullets:

- The performance of these batteries far exceeds the capacity performance of all previously tested *Horizon* batteries as reported in the March quarterly report. Further the variance in performance of individual batteries is small
- Amp Hour capacity of all tested modules was near (95%) of the manufactures specifications ($C_3 = 94$ amp hr). As these batteries continue cycling their C_3 capacity will likely increases to the specified value.
- The difference in average capacity of the two groups tested, A and B, is most likely due to a difference in case temperature due to higher ambient air temperatures during cycling.

Recommendations

- Install the latest group of batteries in an electric vehicle and wire them as described in quarterly report 1. The battery placement and containment should account for the strong relationship between capacity and temperature. An attempt should be made to minimize any temperature differences between modules. It is recommended that thermocouples or other measuring devices be placed on strategic batteries within the pack to measure absolute and relative temperatures of the batteries. Shortly after the vehicle is operational bring it to the EVPSL for series/parallel performance characterization. This vehicle should then be place in a high use application that will operate the vehicle 7 days a week, at deep depths of discharge. In one month return the vehicle to the EVPSL for series/parallel performance characterization. Each characterization at the EVPSL will take approximately 4 days.
- Due to differences in published and verbally described charge methods a temperature compensated charging method should be agreed upon and tested on the reference and all subsequent *Horizon* batteries. A clear distinction should be made for module and pack charging methods.
- Due to strong relationship between performance and temperature the resolution of charge temperature compensation should be investigated and agreed upon with Electrosource. Further the case temperature measurement location should be investigated and agreed upon.
- During module testing the daily ambient air temperature fluctuation around the batteries should be minimized by containment with a temperature controlled fan.
- Measures of self discharge and peak power capability of new (>3000 serial number) *Horizon* batteries should be made.

APPENDIX B

**HORIZON® BATTERY
USER'S MANUAL**

Prepared By:

Electrosorce, Inc.

HORIZON[®] Battery Manual

Note

This manual is subject to revision at any time. Please check with Electrosource Customer Support to verify that you have the latest revision.

TABLE OF CONTENTS

CHAPTER 1 - YOUR HORIZON® BATTERY	1-1
HORIZON® Battery Description	1-1
HORIZON® Battery Features.....	1-1
CHAPTER 2 - RECEIVING YOUR BATTERIES	2-1
Safety and Handling.....	2-1
Read this Information.....	2-1
Observe these Important Directions.....	2-1
Unpacking	2-2
Packaging and Shipping.....	2-5
Storing.....	2-8
CHAPTER 3 - INSTALLING YOUR BATTERIES	3-1
Preparing to Install	3-1
Battery Capacity, Size, and Weight	3-1
Battery Terminal Locations	3-1
Terminal Connectors.....	3-2
Connector Crimping Tool	3-2
Charge Control Systems.....	3-3
Battery Chargers	3-3
How to Install.....	3-3
Using Battery Connectors	3-3
Building Battery Cables.....	3-4
Required Charge	3-4
Required Air Space.....	3-4
Battery Orientation.....	3-5
Installing Strings of Batteries.....	3-5
Connecting Batteries in Series	3-5
Connecting Batteries in Parallel.....	3-5
CHAPTER 4 - OPERATING YOUR BATTERIES	4-1
Operating Limits	4-1
Temperature	4-1
Charge	4-1
Discharge	4-1
Charging the Battery	4-1

Table of Contents

Battery Chargers	4-2
Charge Management Systems.....	4-3
Recharging a Discharged HORIZON® Battery	4-3
The Finishing Current.....	4-5
Temperature Compensation of Charge.....	4-5
Charge Management Systems.....	4-6
Rapid Charging.....	4-7
CI/CV/CI Charge Procedure.....	4-7
Recharging a Charged HORIZON® Battery	4-8
CHAPTER 5 - REPLACING YOUR BATTERIES	5-1
CHAPTER 6 - DISPOSING OF YOUR BATTERIES	6-1
Hazardous Material.....	6-1
Recycling	6-1
APPENDIX A - WARRANTY	A-1
APPENDIX B - OTHER REFERENCE DOCUMENTS.....	B-1
APPENDIX C - HORIZON® BATTERY MATERIALS SAFETY DATA SHEET	C-1
I. Product Identification	C-1
II. Hazardous Ingredients.....	C-1
III. Physical Data	C-2
IV. Health Hazard Information.....	C-2
Routes and Methods of Entry	C-2
Signs and Symptoms of Overexposure.....	C-2
Potential Cause of Cancer.....	C-3
Emergency First Aid Procedures.....	C-3
V. Fire and Explosion Data.....	C-4
VI. Reactivity Data	C-4
VII. Control Measures	C-5
Personal Protective Equipment.....	C-5
VIII. Safe Handling Precautions.....	C-5
Spill or Leak Procedures.....	C-6

Table of Contents

IX. Other	C-6
Regulatory Information.....	C-6
APPENDIX D - HORIZON® BATTERY SUMMARY.....	D-1
GLOSSARY	G-1

Table of Contents

List of Figures

Figure 2-1.	12N95 Model Battery Orientation	2-6
Figure 2-2.	12N85 Model Battery Orientation	2-7
Figure 3-1.	Required Air Space Between Batteries.....	3-4
Figure 3-2.	Connecting Batteries in Series	3-5
Figure 3-3.	Connecting Batteries in Parallel	3-6
Figure 4-1.	Recommended Charge Profile	4-3

List of Tables

Table 4-1.	Estimated Recharge time of Single Batteries from 80% Depth of Discharge	4-5
Table D-1.	HORIZON® Battery Summary, Available Models.....	D-1

CHAPTER 1 - YOUR HORIZON[®] BATTERY

HORIZON[®] Battery Description

The HORIZON[®] battery uses an innovative energy-storage technology that brings the promise of tomorrow's batteries to today's market at an affordable price. The battery uses a Valve-Regulated, Lead-Acid technology that combines advances in material design with well documented lead-acid electrochemistry and it is produced using processes that take advantage of the vast supply and recycling infrastructure already in place for conventional lead-acid batteries.

HORIZON[®] technology begins with a wire created by co-extruding lead over high-tensile-strength, lightweight, fiberglass filaments. Use of the lead/glass structure allows a higher purity lead content, thereby minimizing gassing on charge and creating high resistance to corrosion while maintaining structural integrity. The co-extruded wires are woven on large industrial looms into lightweight mesh grids, which are then coated with a proprietary active material. These "bi-grids" are robotically assembled horizontally instead of vertically (as configured in traditional lead-acid batteries) and secured by a patented compression assembly. Finally, the battery is filled with electrolyte, then drained, leaving just enough absorbed electrolyte to allow the optimum electrochemical reactions to occur.

HORIZON[®] Battery Features

The following features enable the HORIZON[®] battery to deliver many more charge and discharge cycles with greater energy and power per kilogram than other Valve-Regulated Lead-Acid batteries, resulting in the following competitive advantages:

- **High Energy**

Reduced weight yields energy per kilogram in a class with advanced-materials research batteries and as much as twice that of conventional lead-acid batteries.

Chapter 1 - Your Horizon® Battery

- **More Power**

The peak power per kilogram exceeds that of any conventional or advanced-material battery in production today, resulting in superior acceleration when used in electric vehicles.

- **Long Life**

The advanced metallurgy, high-tensile-strength battery grid is highly resistant to corrosion and structural failure. The battery delivers more charge and discharge cycles than other VRLA battery designs when proper handling and care is applied.

- **Environmentally Friendly**

Electrosource uses “green” manufacturing processes to comply with the highest U.S. environmental standards. Moreover, the HORIZON® battery is 98% recyclable by existing reclamation methods.

- **Safe and Maintenance-free**

With the HORIZON® sealed battery technology, there is no free electrolyte in the battery. Therefore, the potential for spills is eliminated and you never need to add water.

The result of this revolutionary technology is a “new class” of battery competitive in price and performance with newer advanced batteries. The HORIZON® is a lightweight, compact, environmentally sound battery which requires no maintenance, yet produces high energy and power.

CHAPTER 2 - RECEIVING YOUR BATTERIES

Safety and Handling

The following information applies to Safety and Handling, Unpacking, Packing and Shipping Batteries. When you receive your batteries, observe the following instructions and cautions. Failure to do so could result in injury.

WARNING

Lead-acid batteries contain certain toxic and corrosive chemicals, such as lead and acid, and a significant amount of stored electrical energy. It is essential that you read and follow the contents of this manual to avoid hazards, including electrical shock and contact with or release of harmful substances.

Read this Information

Read the following information completely before handling or installing the battery:

- This battery instruction manual
- The Materials Safety Data Sheet
(See "Appendix C - HORIZON[®] Battery Materials Safety Data sheet" beginning on page C - 1.)

Observe these Important Directions

Read the following information and observe the instructions and cautions:

- The battery contains highly corrosive acid that can leak. If suspicious or corrosive material contacts the skin or eyes, flush immediately with water for 15 minutes and seek medical help.
- Wear appropriate eye protection, acid resistant gloves, and acid resistant protective clothing at all times when handling, installing, charging, or servicing the battery.
- Never touch both battery terminals at the same time. When batteries are connected in a string, voltages greater than 48V can cause severe shock and injury.

Chapter 2 - Receiving Your Batteries

- Do not allow metallic objects to simultaneously touch the positive and negative terminals of the batteries.
- Do not attempt to modify the battery or open the outer plastic container.
- Do not use the battery if it exhibits signs of damage, cracks, leaks, or swelling.
- Do not expose the battery to flames, sparks, or heat at any time.
- Do not smoke in the vicinity of the battery at any time.
- Never attempt to remove the pressure valve or otherwise tamper with the battery.
- Always store the battery in a safe place at temperatures between -40°F and 140°F (-40°C to 60°C).
- Connecting batteries in a string or pack requires special care and procedures and should be conducted by trained personnel only. High voltage may be present.
- When batteries are connected in strings or packs, high voltage can be present. Never allow water to touch the batteries as this may cause an explosion. Refer to the National Fire Safety Code for information about how to safely handle high voltage applications.

Unpacking

Batteries are carefully packaged for safe shipping but damage in shipment can occur. Unpack and inspect the batteries carefully in order to ensure your safety and that the batteries are received in good condition by performing the following steps:

1. Inspect the shipping container for damage before unpacking the battery. Report any apparent damage due to shipping to your company's transportation department. File claims for damage due to shipping with the shipping company as soon as possible to ensure coverage.

Unpacking

2. Inspect labels on the outside of the packing case or shipping documents which give the following information:

Battery Serial Number
Corrosive Substance Number (8)
Hazardous Material Classification Number
(UN2800)
Orientation of the Battery (e.g. This Side Up)

Compare the battery serial numbers on the outside of the packing cases or batteries with those shown on the shipping notice. If there is a discrepancy between the numbers, call Electrosource Customer Support. Do not open the packing cases further until instructed to do so by Electrosource.

3. If the batteries have been delivered on a pallet, carefully cut the steel banding. Unpack the batteries using acid resistant gloves, appropriate protective eye wear and acid resistant protective clothing. Assume any liquids found inside the packaging are dangerous and corrosive.

WARNING

Batteries are heavy! Use lifting aids or back supports.

CAUTION

Always support the battery along the bottom when carrying.

Never pick the battery up by the terminals.

4. Lift the batteries off the pallet one at a time and set them on the floor.

CAUTION

Dropping the battery may damage it internally or crack the case. If the battery is dropped, do not use it.

Chapter 2 - Receiving Your Batteries

5. If batteries have been delivered in packing cases, carefully remove the tape and open the packing case. Remove the end and side packing pieces but do not discard them. Tilt the battery slightly and grip one end of the battery at its base. Grip the other end of the battery at its base. Carefully lift the battery onto a table for inspection leaving the terminal protectors on. Do not remove the terminal protectors until installing the battery in an application.

CAUTION

If the battery is damaged or cracked, do not handle or use.

6. Inspect battery cases for cracks and terminals for possible damage immediately. Perform the following steps for batteries with cracks:

Put duct tape over the cracks.

Put battery in a plastic bag.

Put back into the packing box or pallet along with the packing pieces.

If you hear hissing or whistling noises coming from the battery, do not use. The battery may be damaged.

Call Electrosource Customer Support. Have the following information ready:

Purchase Order Number
Battery Serial Number(s)
Date Received

Electrosource will assign a Returned Goods Authorization (RGA) number to you for return of your battery and work with your purchasing organization to arrange for a replacement battery.

7. Do not dispose of the packing cases or the packing pieces. Store them in a safe place - they will be useful

when it comes to disposal of the batteries in an environmentally safe manner in the future.

Packaging and Shipping

Follow the procedures listed below if you need to pack and ship the batteries:

1. Fully charge the batteries before shipping (unless you are returning a damaged shipment). (Returning damaged shipments is described in Step 6 under "Unpacking".) This may be done individually for each battery or in a string if appropriate charging procedures outlined in this manual are followed. (See "Charging the Battery" on page 4 - 1.)
2. Replace the terminal protectors before packing for shipping. Do not ship without the terminals protected.
3. Place the batteries in appropriate Department of Transportation (DOT) approved containers or pallets for wet non-spillable lead-acid batteries.

Ensure that the battery is placed in the shipping container with the top or bottom up. Do not stand the battery on either end or place it on its side. See Figures 2-1, and 2-2 for proper battery orientation.

For more information on DOT regulations, see "Appendix B - Other Reference Documents" on page B - 1.

Chapter 2 - Receiving Your Batteries

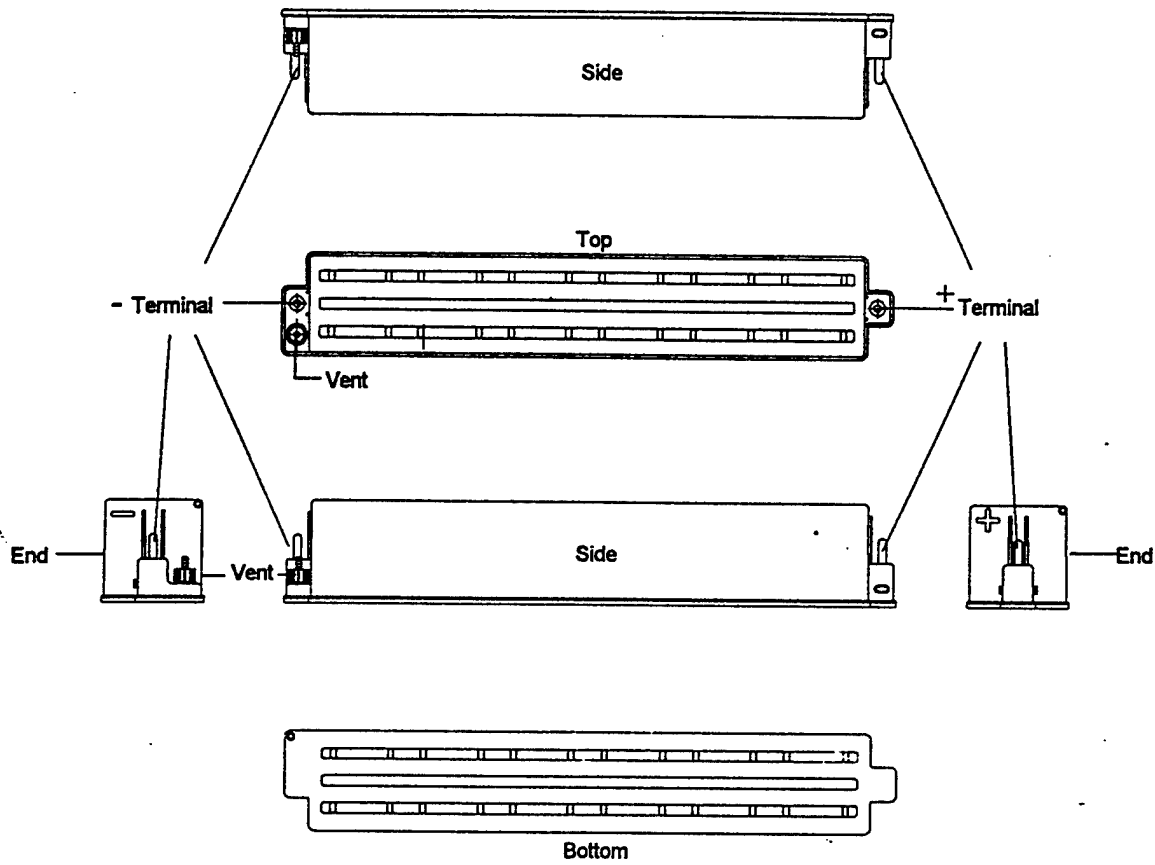

Figure 2-1. 12N95 Model Battery

Packaging and Shipping

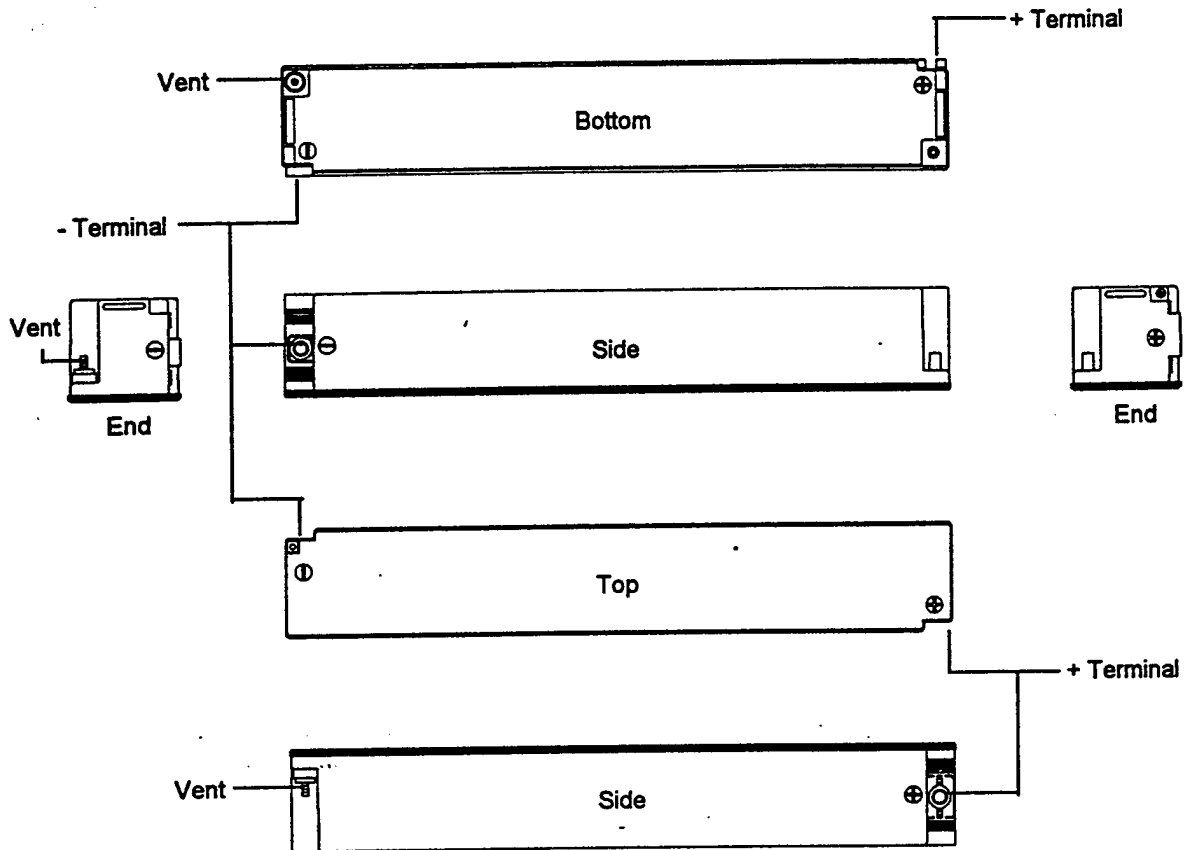

Figure 2-2. 12N85 Model Battery

4. Pack with a minimum of 1/4 inch air space between batteries. Use styrofoam or wood spacers between batteries and shipping container so that batteries will not slide, dislodge or move in the container during shipping.
5. Label the package with the required warning and information labels (consult your shipping department or Freight carrier).
6. Ship only through carriers that are certified to ship wet non-spillable lead-acid batteries.
7. Clearly label the top of the container with the words "THIS SIDE UP."

Chapter 2 - Receiving Your Batteries

Storing

Store batteries in a well ventilated National Fire Safety (NFS) Code approved storage facility with appropriate fire safety equipment for your area. (See "Appendix B - Other Reference Documents" on page B - 1.)

Maintain the temperature for stored batteries between -40°F and 140°F (-40°C to 60°C).

CAUTION

The storage life of the battery is > 90 days if a constant storage temperature of approximately 80°F is maintained. Extremely hot temperatures (greater than 140°F/60°C) may damage the battery and will shorten the shelf life significantly. Cold temperatures affect how readily the battery accepts a charge.

For warranty purposes as well as optimal performance and extended storage life, if storage for more than 30 days is intended, fully recharge the batteries every 30-45 days using the recommended charge procedure in this manual. (See "Recharging a Charged HORIZON® Battery" on page 4-8).

Store the battery with terminal protectors on both terminals.

Protect the battery from direct sunlight.

CHAPTER 3 - INSTALLING YOUR BATTERIES

Preparing to Install

Before installing your batteries in your application, the following information must be considered:

- Capacity required for your application
- Physical size of the battery
- Weight of the battery
- Terminal locations
- Terminal connectors
- Charge Management System
- Charger

Battery Capacity, Size, and Weight

Table D-1 in Appendix D details the approximate capacity and physical characteristics of the battery. Use this information when designing your application.

Battery Terminal Locations

Refer to Figures 2-1 and 2-2 for the locations of the terminals on the various battery models.

Terminal Connectors

The only connector presently approved for use on the 12N95 battery is the RADSOK® 10 millimeter diameter connector.

The only connector presently approved for use on the 12N85 battery is the RADSOK® supertwist 10 millimeter pin (terminal).

Special terminal-connectors are required for connecting batteries in parallel strings.

Chapter 3 - Installing Your Batteries

These may be ordered from:

KONNEKTECH, Inc.
34230 Riviera Drive
Fraser, MI 48026 U.S.A.
Phone: (810) 294-7400
Fax: (810) 294-7402

When ordering RADSOK® connectors, request the "Guidelines for Crimping RADSOK® Electrical Connectors."

Connector Crimping Tool

The crimping tool approved for crimping RADSOK® connectors is the Model VC6-3 Versa-Crimp hydraulic hand operated compression tool with type VCHTG direct reading pressure gauge by Anderson Products.

Note

Soldering the RADSOK® connector to its cable is not recommended. Heat relaxes connector contact pins which in turn will damage the battery terminal pins at high power.

The crimping tool may be ordered from:

Anderson Products
Div. of Square D
P.O. Box 455
Leeds, Alabama 35094
Phone: (205) 699 2411
Fax: (205) 699-7603

Refer to the "Guidelines for Crimping RADSOK® Electrical Connectors" when crimping RADSOK® connectors.

Charge Control Systems

You must install a Battery Management System (BMS) or Charge Management System (CMS) in your application if the batteries are to be connected in a string. The BMS/CMS controls the charger and gets status information from the battery. (See "Charge Management Systems" on page 4-6.) The Charge Management System combined with the Charger enables you to properly recharge your battery.

Note

Failure to use an approved BMS/CMS will void your warranty, could ruin the batteries, and will likely result in unsatisfactory battery performance or life.

Battery Chargers

Use battery chargers that are approved for use with the HORIZON® battery. (See "Battery Chargers" on page 4-2)

How to install

Installing the HORIZON® battery requires the following items to be considered:

- Connectors
- Cables
- Minimum air space for ventilation
- Correct physical orientation
- Wiring together in series or in parallel

WARNING

Do not expose the battery to flames, sparks, or heat sources at any time.

Using Battery Connectors

Use the appropriate RADSOK® terminal connectors for your HORIZON® battery type. (See "terminal connectors" on page 3-1)

Building Battery Cables

Use the appropriate wire size when building cables for your electrical application. Refer to Ampacity Tables and Fusing Requirements set by the National Electrical Code for guidelines when choosing the correct cable size for your current requirements. (See "Appendix B - Other Reference Documents" on page B - 1.)

Required Charge

Be sure to charge the battery immediately before installing in any application. (See "Recharging a charged HORIZON Battery" on page 4-8).

Chapter 3 - Installing Your Batteries

Required Air Space

Provide 1/4 to 1/2 inch of air space on all sides of each battery. (See "Figure 3-1 - Required Air Space Between Batteries").

Air space = 1/4 in to 1/2 in (.635 cm to 1.270 cm) minimum

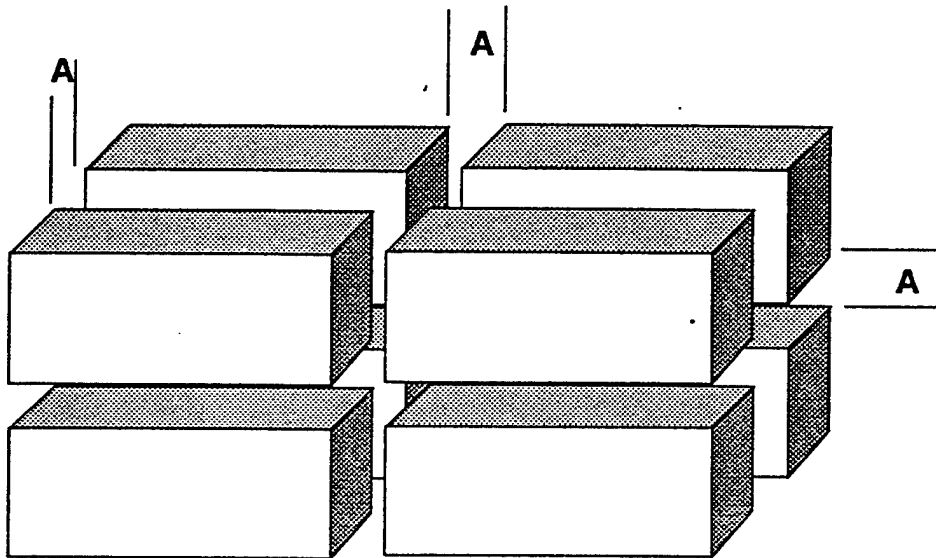

Figure 3-1. Required Air Space Between Batteries

Batteries must be mounted and supported in appropriate trays or brackets specifically designed for the application so that the batteries are prevented from excessive vibration or movement in their container.

Battery Orientation

The batteries should be positioned with either the top or bottom up. Do not place batteries on their sides or standing on end to operate, as this will cause damage to the battery. See Figures 2-1 and 2-2 for proper battery orientation.

Installing Strings of Batteries

WARNING

Connecting batteries in a string or pack requires special care and procedures and should be conducted by trained personnel only. High voltage may be present.

Preparing to Install

Connecting Batteries in Series

When connecting batteries together in series, connect the positive terminal to the negative terminal using RADSOCK® pins or cables as shown in the following figure:

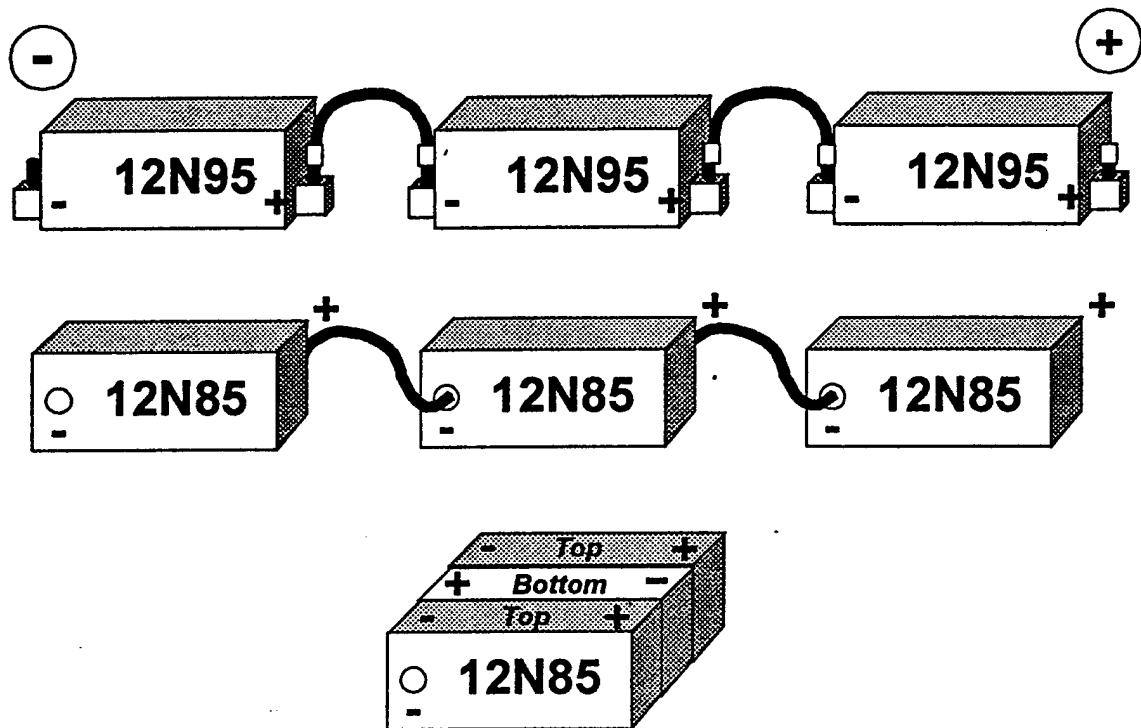

Figure 3-2. Connecting Batteries in Series

Connecting Batteries in Parallel

When connecting batteries together in parallel, connect the positive terminal to the positive terminal and the negative terminal to the negative terminal as shown in the following figure (The 12N85 can be connected using pins only. Contact KONNEKTECH for information.):

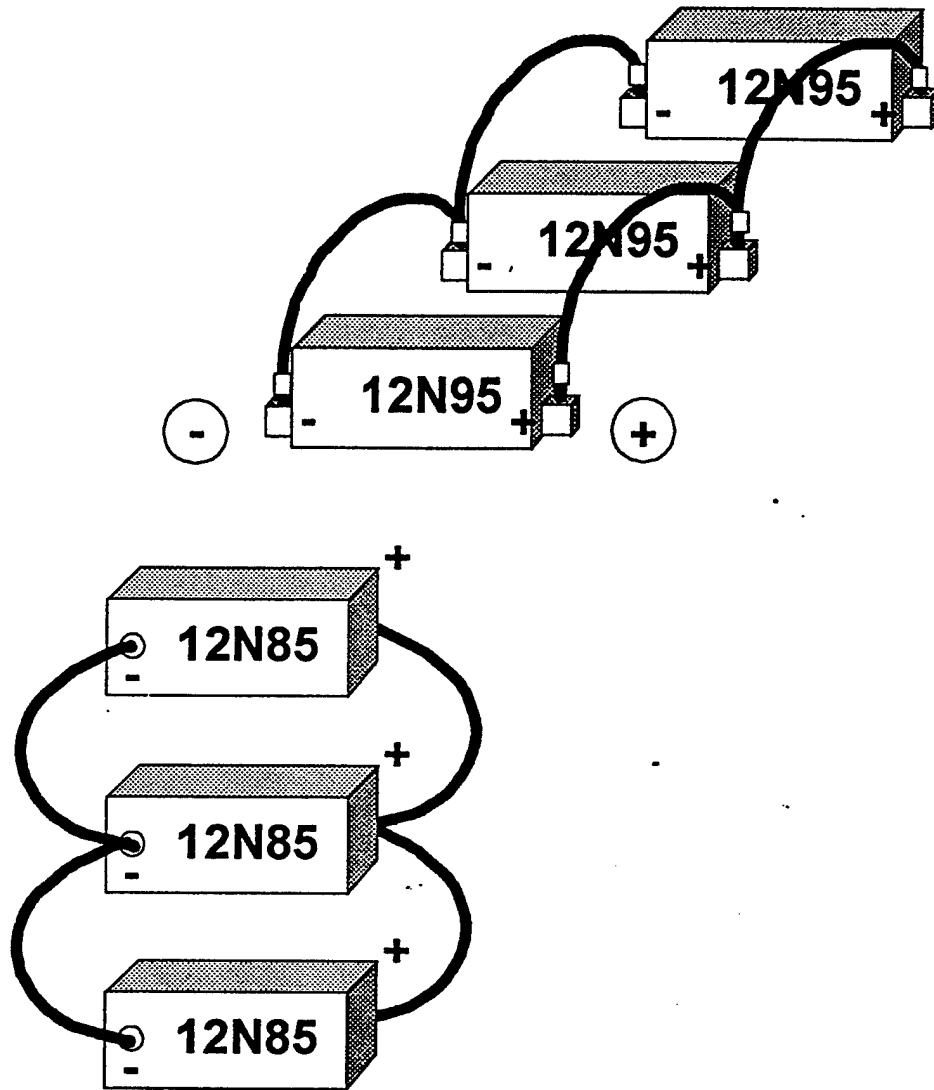

Figure 3-3. Connecting Batteries in Parallel

Special RADSOK® connectors are required to connect batteries in parallel strings. Call KONNEKTECH to get these connectors. (See "terminal connectors" on page 3-1.)

Install the batteries in the following sequence:

Preparing to Install

1. Place all batteries that are required for your application in the tray(s) or container(s) that will hold them in place.
2. Measure the distances between the battery terminals for cable lengths.

Allow for any normal motion that could affect cable length, and allow for the appropriate crimp and connector distance.

3. Cut appropriate size cables to correct lengths.
4. Crimp RADSOK® connectors to cable ends.

Refer to the "Guidelines for Crimping RADSOK® Electrical Connectors" when crimping RADSOK® connectors.

CHAPTER 4 - OPERATING YOUR BATTERIES

Operating Limits

The information in this section details the limits within which the HORIZON® battery should be operated. Exceeding these limits may cause lowered battery performance or life.

Temperature

The operating temperature range is -22°F to +122°F (-30°C to 50°C). Prolonged operation above 122°F (50°C) greatly reduces battery life. Exposure to cold temperatures reduces the ability of the battery to accept charge.

Charge

Charge with an Electrosorce approved charge profile only. (See "Figure 4-1 - Recommended Charge Profile" on page 4 - 3.)

Discharge

The HORIZON® battery should not be discharged beyond 80% Depth of Discharge (DOD) as defined in Appendix G.. Consistently discharging the battery beyond 80% DOD will shorten its life. When discharging strings of batteries with a BMS installed, a warning signal should occur when the 80% DOD value is reached on the lowest capacity battery. See Appendix D for terminal ratings of HORIZON® batteries.

Charging the Battery

The technological design of the HORIZON® battery is known as "sealed, recombinant" lead-acid often referred to as Valve Regulated Lead Acid (VRLA). Excessive overcharge will result in gas formation inside the case which is relieved by the automatic opening of the pressure relief valve (set at 1.5 psi ±0.5 psi). Every time the valve opens, water vapor will be lost and the battery capacity and/or life will be reduced.

To achieve maximum cycle life, the battery must not be excessively overcharged.

**Battery
Chargers**

The proper charging of a HORIZON® battery is essential to its life and performance.

Call ELSI Customer Support for recommendations on where to obtain chargers meeting the following specifications:

- Less than 5% ripple with the battery connected.
- Charge output follows approved HORIZON® battery profile for single or series connected batteries. (See "Figure 4-1 - Recommended Charge Profile" on page 4 - 3.)
- Programmable with the ELSI recommended charge profile.
- For series/parallel connected batteries, the charger must be controllable by a charge control system that properly charges the battery according to the recommended ELSI charge profile.

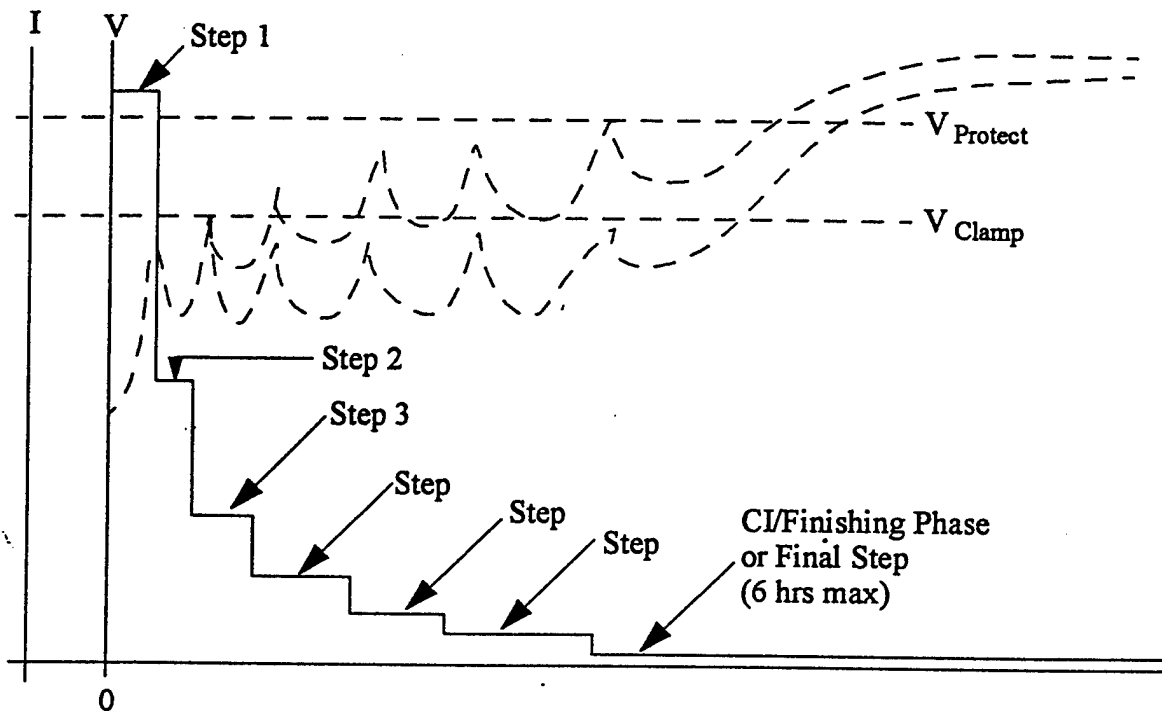

I = Current
 V = Voltage
 CI = Constant Current

Current: _____
 Resulting Voltage: - - - - -

Note: These values apply to charging a battery with an initial temperature of 77°F

Figure 4-1. Recommended Charge Profile

Charge Management Systems

If you are charging more than one battery, e.g. a series-string of batteries, you must use a Charge Management System. (See "Charge Management Systems" on page 4 - 6.)

Recharging a Discharged HORIZON® Battery

Note

Charge batteries with the Electrosource approved HORIZON® charge profile only. (See "Figure 4-1 - Recommended Charge Profile".)

Note

If recharging a HORIZON[®] battery in a charged state, as in a storage condition where only an Open Circuit Voltage loss has been affecting the battery prior to use, see "Recharging a Charged HORIZON[®] Battery" on page 4-8.

Note

The following steps apply to a battery with an initial temperature of 77°F(25°C). (See "Temperature Compensation of Charge" on page 4 - 5.)

Perform the following steps when charging a single battery or a battery pack:

1. When charging a string of batteries, use constant current to charge batteries until the first battery reaches V_{protect} or until all batteries reach V_{Clamp} , whichever occurs first. (See Table 4-1 on page 4-5)

Note

If the V_{protect} temperature compensated ceiling were not used as an alternative trigger to reduce current, the result might be damaged batteries in the event of a bad module or a pack with a large difference in battery capacities.

2. Reduce the current to approximately 50% of the initial inrush current.
3. Each time any battery reaches V_{protect} or all batteries reach V_{Clamp} , reduce the current by half until it equals the finishing current value listed in Table 4-1 for that model battery.
4. Continue charging the batteries using the (1% of C-rating) finishing current until all battery voltages have risen less than 0.01 V in a 15 minute period. The time

Chapter 4 - Operating Your Batteries

for this final phase must not exceed 6 hours. Do not allow voltage for any battery to exceed V_{eq} for this last phase only. This last charge phase allows each battery in the pack an opportunity to balance capacity at a safe current level with minimal gassing and is critical to correct pack management.

Table 4-1. Estimated Recharge time of Single Batteries from 80% Depth of Discharge

HORIZON [®] Battery Model	Suggested Inrush Current I_s (A)	String Clamp Voltage V_{clamp} (V)	String Protect Voltage $V_{protect}$ (V)	String Equalization Voltage V_{eq} (V)	Module Clamp Voltage V_c (V)	Estimated Time to Recharge from 80% DOD (hrs)	CI/ Finishing Current I_f (A)
12N95	50	14.25	15.5	16.5	14.4	2.6	1.0
12N85	45	14.25	15.5	16.5	14.4	2.6	1.0
12U60	32	14.25	15.5	16.5	14.4	2.6	0.6
12U40	21	14.25	15.5	16.5	14.4	2.6	0.4
12U20	10.5	14.25	15.5	16.5	14.4	2.6	0.2
PowerCore I	13	28.8	31	32	29.4	2.6	0.25
24UV25	25	28	30	32	28	2.6	0.2
24UV50	50	28	30	32	28	2.6	0.5

The Finishing Charge

Individual battery voltages and temperature can be monitored using a charge management system or a battery monitoring system. In addition, a charge management system allows closed-loop control of the charger and provides a means for applying the finishing current to the battery.

Temperature Compensation of Charge

The ambient temperature of a battery greatly affects its ability to accept charge. The colder the battery, the less readily it accepts the charge. Therefore, clamp voltages used during battery charging must be adjusted to compensate for initial temperature variations.

Charge Management Systems

WARNING

Do not charge the battery if the initial battery temperatures exceeds 122°F (50°C) or thermal runaway may occur.

Alter the clamp voltage (V_c) to compensate for variations in initial battery temperatures according to the following:

For initial battery temperatures above 77°F:

Subtract (0.001 * nameplate voltage) VDC per °F above 77°F from clamp voltage. For example: a 12V battery like the 12N85 would use $0.001 * 12 = 0.012$ VDC, while a 24V battery like the 24UV50 would use $0.001 * 24 = 0.024$ VDC.

For initial battery temperatures below 77°F

Add (0.001 * nameplate voltage) VDC per °F below 77°F to the clamp voltage.

Measure the temperature near the center of the top-most part of the battery.

Charge Management Systems

Note

Failure to use an approved charge management system will void your warranty and will result in unsatisfactory battery performance or battery life.

No matter how precisely batteries are manufactured, there will be inherent differences in their available capacities due to age and temperature variations within a pack of batteries. Bulk charging packs of batteries where only the average pack voltage and temperature are monitored causes some batteries to be overcharged and some to be undercharged. Over a number of cycles the imbalances in the batteries of a pack increase and the overall available energy from the pack decreases, being limited by the battery in the pack that has accepted the least amount of charge during that cycle.

Chapter 4 - Operating Your Batteries

The solution to this problem is to install a Charge Management System (CMS) which monitors the voltage and temperature of individual batteries in a pack and administers the optimum amount of charge current to modules without overcharging or undercharging them. This extends the battery life and maintains the available capacity over time.

Note

For more information concerning the approved Charge Management Systems, call ELSI Customer Support .

Rapid Charging

Electrosource does not have sufficient information on the effects of rapid recharge on battery cycle life to recommend a rapid charge algorithm at this time. If you have a need for this procedure, Electrosource will provide technical information on an individual basis.

CI/CV/CI Charge Procedure

This charge procedure may be used for single module charging as an alternative to the recommended Multi-step standard charge algorithm previously described. When the Voltage Clamp has been reached at the initial inrush current level, the charge current is slowly tapered until a final minimum is reached, then the voltage clamp is removed. The charge is finished at a low fixed current level with the battery voltage allowed to rise.

STEP 1 - CONSTANT CURRENT: This procedure starts with a recommended inrush current for each HORIZON[®] battery (See Table 4-1 on page 4-5). This would continue until the module reaches V_c .

Note

This is a variation from the Multi-step Voltage Clamp described in Table 4-1.

STEP 2 - CONSTANT VOLTAGE: The charge voltage is then clamped at V_c and the charge current is tapered to a minimum value, the finishing current described in Table 4-1.

STEP 3 - CONSTANT CURRENT: This finish current level is then held constant at the recommended levels described in Table 4-1. This level is maintained for 30 minutes after $dV/dt =$

Recharging a Charged HORIZON® Battery

0 or a maximum of 2 hours is reached. This provides a battery to charge to its maximum capacity value at a safe level of charge current.

When recharging a battery at near its full state of charge, such as when the only charge drain has been during storage or shipping, a modified procedure should be used. Charge batteries with the Electrosource approved profile only or shortened storage life and potential damage to the battery may occur.

RECHARGE: Follow the Multi-step charge algorithm described in Figure 1 EXCEPT begin with an inrush current as shown in Table 4-1. Follow the stepwise reduction in current by 50% each time the appropriate voltage clamp is attained. The same finishing current procedure previously described is followed to equalize charge.

Note

Using a full inrush current on a nearly fully charged battery may result in shorter storage life, depending upon response times of the charger used. For this reason, a 6A inrush current is recommended for RECHARGE. After C/3 discharge, the battery will have no problem accepting the full recommended inrush current without overheating.

CHAPTER 5 - REPLACING YOUR BATTERIES

Identifying Bad Batteries

A number of different methods may be used to identify a limiting or bad battery in a string of HORIZON batteries. Once the battery has been identified as needing replacement, perform the following steps:

WARNING

Follow proper safety precautions regarding high voltage, lead, and sulfuric acid when removing or installing batteries from the vehicle.

1. Charge the vehicle using the Electrosorce recommended charge profile. (See "Figure 4-1 - Recommended Charge Profile" on page 4 - 3.)
2. Disconnect the high-voltage leads from any external devices.
3. Disconnect the identified battery from the battery string. Ensure that proper safety precautions are taken to avoid high-voltage hazards.
4. Be sure to charge the replacement battery using ELSI recommend charging methods. (See "Figure 4-1 - Recommended Charge Profile" on page 4 - 3.)
5. Install the charged replacement battery making sure the terminal leads are properly connected to the positive and negative terminals of adjacent batteries. (See "Charging the Battery" on page 4 - 1.) This battery should read an open circuit voltage of at least 12.5 V.
6. Reconnect main high voltage leads to desired external devices, taking precautions to avoid high voltage hazards.

CHAPTER 6 - DISPOSING OF YOUR BATTERIES

Hazardous Material

The HORIZON[®] lead-acid battery contains hazardous material (lead and sulfuric acid). You must follow federal, state, and local laws when disposing of used batteries.

Recycling

Spent batteries should be recycled at a lead recycler. Call Electrosource Customer Support to obtain the name of the nearest approved lead recycler in your area. When disposing of a spent HORIZON[®] battery, it may not be necessary to repack the battery in the original container. Contact the lead recycler for their requirements.

APPENDIX A - WARRANTY

6-Month Warranty for Materials and Workmanship

Generally, subject to the specific warranty received with your purchase, all products will be replaced for defects in materials and workmanship free of charge (except for shipping and handling) for a period of six months from delivery to the customer. Damage caused in shipment will be the responsibility of the shipping agent. Damage or failures caused by misuse or noncompliance with product instructions will be the responsibility of the customer and may void the warranty. Any warranty other than described herein will be covered under separate documentation and may be negotiated individually with customers.

There are no other warranties of any kind express or implied, including, without limitation, merchantability or fitness for a particular purpose.

Failure to use an approved Charge Management System with batteries connected in a string will void your warranty.

APPENDIX B - OTHER REFERENCE DOCUMENTS

The following documents provide additional information that applies to handling and shipping of the HORIZON® Battery:

ATA (1992). Part 49, Section 172.101. Code of Federal Regulations (CFR).

IATA (1995). Dangerous Goods Regulations, 36th Edition.

The following document provides additional information that applies to storing the HORIZON® Battery.

(1995). National Fire Safety (NES) Code.

The following document provides additional information that applies to installing the HORIZON® Battery.

(1995). National Electrical Code.

APPENDIX C - HORIZON[®] BATTERY MATERIALS SAFETY DATA SHEET

I. Product Identification	
Chemical/Trade Name	Lead Acid Battery
Chemical Family/Classification	Sealed Lead Acid Electric Storage Battery
Company Name	Electrosource, Inc.
Address	2809 Interstate Highway 35 South San Marcos, TX 78666-5930
Telephone Numbers: Office Customer Support	(512) 753-6500 (800) 298-3574
Date Prepared	6/21/95
Transportation Emergencies	Call CHEMTREC (800) 262-8200

II. Hazardous Ingredients				
Material	% by Wt or Vol	CAS Number	Exposure Limits	
			OSHA	ACGIH
Lead	15 - 30	7439-92-1	0.05 mg/m ³	0.15 mg/m ³
Lead Compounds	25 - 50	1309-60-0	0.05mg/m ³	1.0 mg/m ³
Electrolyte	15 - 35	7664-93-9	1.0 mg/m ³	1.0 mg/m ³
Case Material (Polypropylene)	3 - 8	9003-07-0	N/A	N/A

Appendix C - Horizon® Battery Materials Safety Data Sheet

III. Physical Data	
Materials (at normal temperature)	Electrolyte (sulfuric acid and water)
Boiling Point (at 760 mm Hg)	229 - 248 Degrees Fahrenheit 109 - 120 Degrees Celsius
Melting Point	N/A
Specific Gravity (H ₂ O = 1)	1.100 - 1.350
Vapor Density (air = 1)	Greater than 1
% Volatiles by weight	N/A
Appearance and odor	Electrolyte (sulfuric acid and water) is a clear liquid with a sharp, penetrating, pungent odor.
Vapor Pressure (mm Hg at 20°C)	10
Solubility in water	100% for sulfuric acid (electrolyte) Low solubility for other components.
Evaporation Rate (Butyl Acetate = 1)	Less than 1

IV. Health Hazard Information	
Routes and Methods of Entry	
Inhalation	High levels of sulfuric acid vapors or mist may cause severe respiratory irritation.
Skin Contact	Sulfuric acid may cause severe irritation, burns, and ulceration.
Skin Absorption	Sulfuric acid is not readily absorbed through the skin.
Eye Contact	Sulfuric acid vapors or mist can cause severe irritation, burns, cornea damage, and possible blindness. Lead compounds may cause severe eye irritation.

Appendix C - Horizon® Battery Materials Safety Data Sheet

IV. Health Hazard Information	
Ingestion	Sulfuric acid may cause severe irritation of the mouth, throat, esophagus, and stomach. Lead compounds may cause abdominal pain, nausea, headaches, vomiting, diarrhea, and severe cramping. Acute indigestion should be treated by a physician.
Signs and Symptoms of Overexposure	
Acute Effects	Sulfuric acid may cause severe skin irritation, burns, damage to the cornea, and possible blindness and upper respiratory irritation. Lead compounds may cause abdominal pain, nausea, headaches, vomiting, diarrhea, severe cramping, and difficulty in sleeping.
Chronic Effects	Sulfuric acid may lead to the scarring of the bronchial tubes and possible erosion of tooth enamel. Lead compounds may cause anemia, damage to the kidneys, and damage to the nervous system. Lead compounds may cause reproductive changes in both males and females.
Potential to Cause Cancer	
	Lead has been tested for the ability to cause cancer. The results have shown that lead may or may not cause cancer.
Emergency and First Aid Procedures	
Inhalation	Sulfuric acid- Remove to fresh air immediately. If breathing is difficult, give oxygen. Consult a physician.
	Lead compounds- Remove from exposure, gargle, wash nose and eyes. Consult a physician.
Skin	Sulfuric acid- Flush with large amounts of water for at least 15 minutes. Remove any contaminated clothing and do not wear again until cleaned. If acid is splashed on shoes, remove and clean.
	Lead compounds are not absorbed through the skin.

Appendix C - Horizon® Battery Materials Safety Data Sheet

IV. Health Hazard Information	
Eyes	Sulfuric acid- Flush immediately with cool water for at least 15 minutes. Consult a physician.
	Lead compounds- Flush immediately with cool water for at least 15 minutes. Consult a physician.
Ingestion	Sulfuric acid- Give large quantities of water. Do NOT induce vomiting. Consult a physician.
	Lead compounds- Consult a physician.

V. Fire and Explosion Data	
Flash Point	N/A
Flammable Limits	N/A
Extinguishing Media	CO ₂ , foam, dry chemical
Special Fire Fighting Procedures	If batteries are on charge, turn off the power. Use positive-pressure, self-contained breathing apparatus. Fires involving batteries connected in high voltage strings (2 or more batteries connected in series) create a special hazard and are classified as Class C fires. Extinguishers that may be used include carbon dioxide, dry chemical types and FM200. Do not use water to extinguish a fire involving strings of batteries because of the risk of electrocution and explosion. Wear clothing resistant to sulfuric acid.

Appendix C - Horizon® Battery Materials Safety Data Sheet

V. Fire and Explosion Data

Unusual Fire and Explosion Hazard	Oxygen gas is produced in the cells during normal battery charging and is recombined during the operational cycle. If the battery is overcharged, hydrogen gas may be produced (hydrogen is highly flammable and oxygen supports combustion). These gases enter the air through the pressure relief valve when the battery is overcharged. To avoid risk of fire or explosion, charge the battery per the manufacturer's instructions only. Keep sparks and other sources of ignition away from the battery. Do not allow metallic material to simultaneously contact both the positive and negative terminals of the battery. Follow manufacturer's instructions for installation and operation.
-----------------------------------	---

VI. Reactivity Data

Stability	Stable
Conditions to Avoid	Sparks and other sources of ignition. Prolonged overcharge. Operation in ambient temperatures above 120°F (49°C).
Hazardous Decomposition Products	Sulfuric acid, oxides of sulfur, hydrogen sulfide, and sulfuric acid mist.
Hazardous Polymerization	Will not occur.

Appendix C - Horizon® Battery Materials Safety Data Sheet

VII. Control Measures	
Engineering Controls	Store and handle lead-acid batteries in well ventilated areas.
Work Practices	Make certain the battery is sealed. Do not stack more than two layers high. Use a minimum of two layers of cardboard between layers of batteries. Do not allow metallic objects to simultaneously touch the positive and negative terminals of the batteries. Use a battery carrier to lift a battery or place hands on opposite corners to avoid damaging the battery. Avoid contact with internal components of the battery. Avoid dropping or bumping the battery.
Personal Protective Equipment	
Respiratory Protection	None is required under normal conditions. If concentrations of sulfuric acid mist are known to exceed the PEL, use NIOSH or OSHA approved respiratory protection.
Eyes and Face	Chemical splash goggle or face shield.
Hands, Arms, Body	Rubber or plastic acid resistant gloves with elbow length gauntlet.
Other Special Clothing and Equipment	Acid resistant apron. Under severe exposure or emergency conditions, wear acid resistant clothing and boots.

Appendix C - Horizon® Battery Materials Safety Data Sheet

VIII. Safe Handling Precautions	
Hygiene Practices	Wash hands thoroughly before eating, drinking, applying cosmetics, or smoking after handling batteries.
Protective measures to be taken during non-routine tasks including equipment maintenance	Do not overcharge batteries - may cause the release of hydrogen gas. Do not allow ignition sources in charging area. Post "No Smoking" signs.
Spill or Leak Procedures	
Protective measures to be taken if material is released or spilled	Remove combustible material and all sources of ignition. Stop flow of material and contain spill by diking with soda ash (sodium carbonate) or quick lime (calcium oxide). Carefully neutralize the spill with soda ash or quick lime. Make certain that the mixture is neutral, then collect the residue in a drum or other suitable container. Dispose of the mixture as a hazardous waste. If the battery is leaking, put duct tape over the cracks, then place the battery in a plastic bag.
Waste Disposal Methods	Sulfuric acid- Neutralize as described above for a spill. Collect the residue in a drum or other suitable container. Do not flush lead contaminated acid in the sewer.
	Batteries- Send to a lead recycling facility following applicable federal, state, and local regulations.

Appendix C - Horizon® Battery Materials Safety Data Sheet

IX. Other	
Regulatory Information	
NFPA Hazard Rating for sulfuric acid	Health (Blue) = 3 Flammability (Red) = 0 Reactivity (Yellow) = 2
US DOT Identification and Description for Batteries and Acid	Batteries, wet, non-spillable, electric storage UN2800
Ozone	Lead-acid batteries do not contain any ozone depleting materials.
Reactivity	Sulfuric acid is water reactive if concentrated.
Regulatory Agencies	Batteries are regulated under applicable US DOT, RCRA, CERCLA, and EPCRA.
Cancer	The International Agency for Research on Cancer (IARC) has classified "strong inorganic acid mist containing sulfuric acid" as a Category 1 carcinogen, a substance that is carcinogenic to humans. This classification does not apply to liquid forms of sulfuric acid or sulfuric acid contained within a battery. Inorganic acid mist (sulfuric acid mist) is not generated under normal use of this product. Misuse of the product, such as overcharging, however, may result in the generation of sulfuric acid mist.
Lead and sulfuric acid	Lead-acid batteries are manufactured using lead, CAS No. 7439-92-1 and sulfuric acid, CAS No. 7664-93-9 which are subject to the reporting requirements of EPCRA Section 313 (40 CFR 372).

APPENDIX D - HORIZON[®] BATTERY SUMMARY

Table D-1 HORIZON[®] Battery Summary

Battery Model	Length mm	Width mm	Height mm	Voltage	Weight (Max) kg	Nominal Capacity (A-Hr) @ 25°C			Peak Current Amps	Sp. Power W/kg	Temperature C°	
						Nominal Sp. Energy (Whr/kg) @ 25°C						
						C/3	SFUDS	DST				
12N95	769.8	128.3	132.3	12	27.5	95	89	82.5	78	450	165	Storage -40 to 60
						45***	39.1	35	34.5	740	240	Operating -30 to 50
12N85	767.6	128.3	120.4	12	24.9	85	79.6	73.8	69.8	378	153	-40 to 60
						45	38.4	35.5	33.6	618	223	-30 to 50
12U60	403	255	109	12	18.1	60	56	52	49.3	284	162	-40 to 60
Prototype						42.1	39.3	36.5	34.6	462	243	-30 to 50
12U40	403	255	86.4	12	12.5	40	37	34	32	189	166	-40 to 60
Prototype						41.7	38.6	35.4	33.4	308	241	-30 to 50
12U20	403	255	61	12	7	20	18	17	16	95	162	-40 to 60
Prototype						40.6	36.6	34.6	32.5	154	235	-30 to 50
PowerCore I	276	242	115	24	15	25	N/A	N/A	N/A	N/A	N/A	N/A
Prototype						N/A	N/A	N/A	N/A	N/A	N/A	N/A
24UV50	254	248	263	24	28.2	50	N/A	N/A	41.5	236	164	-40 to 60
Prototype						42.5	N/A	N/A	35.3	385	238	-30 to 50
24UV25	320	167	189	24	16.8	25	N/A	N/A	20.8	160	197	-40 to 60
Prototype						35.7	N/A	N/A	29.7	231	286	-30 to 50

(Prototype weights and sizes may differ slightly)

N/A = Data not available at this time

* Sustained current to 1.5V/Cell limit during 30 second peak power test.

** Instantaneous current available at 80% DOD with 1.5V/Cell limit.

*** 50Wh/kg reached on production modules April 1996.

GLOSSARY

AC	Alternating Current
ACGIH	American Conference for Governmental Industrial Hygienists
A-hr	The symbol for the unit of measurement of capacity of a battery. Ampere-hour.
Algorithm	A prescribed charging procedure for batteries.
Ambient	The temperature of the surrounding environment.
Ampacity	The number of amperes a wire or cable is capable of carrying.
Ampere (A)	A measure of electrical current. The symbol that represents the measure of current is A.
Ampere-hour	The current, (Amperes) times the duration in hours. For example, a battery which delivers 3 amperes for 2 hours has delivered 6 ampere-hours.
BADICHEQ	BAttery DIagnostic CHarge EQualizing. A Battery Management System.
Balancing Charge	A charge procedure performed to maintain or reestablish individual module capacitites; characterized by two different criteria from a standard charge. The Limiting Module is the last to reach Charge Voltage Clamp. The final charge phase current is different from a standard charge - consult battery specification for appropriate data. Balancing Charges are performed as often as necessary to maintain pack balance and may need to be performed in succession before returning to standard charging.
Battery	A single battery. An assembled package of cells. For example, six cells yields approximately 12 volts.

Glossary

Battery Management System (BMS)

Pack charging using Pack Voltage as the charge control parameter is generally not recommended. This method usually leads to damage through undercharging and overcharging of individual modules. Electrosource Inc. recommends the use of a Battery Management System whenever possible. This would include a master controller along with individual module temperature and voltage sensors. The master controller then uses data from individual modules to control the charge and discharge cycles. This can provide optimized pack usage and cycle life.

Battery Pack

A string of batteries connected in parallel or series configuration.

Battery Terminals

The electrical connectors on the battery module.

C/3

The amount of amp-hours discharged from a battery over a three hour period at a constant current equal to 1/3 the rated capacity.

Capacity

The electrical storage capability of the battery, usually measured in ampere-hours delivered at a specified rate of discharge.

Cell

The basic electrochemical unit in the battery. If a HORIZON® battery has six cells that can store 2.257 V per cell, a total of 12 V is available.

Celsius (C)

The international thermometric scale measurement of temperature where the freezing point of water is 0°C and the boiling point is 100°C. $T_c = (T_f - 32)/1.8$

CERCLA

Comprehensive Environmental Response, Conservation, and Liability Act

Charge Management System (CMS)

Monitors the voltage and temperature of individual battery modules in a string and administers the optimum amount of charge current to modules without overcharging or undercharging them.

Glossary

Charger	A device that converts electricity from an AC source into a DC voltage suitable for restoring the charge to a battery module.
CI/CV	Constant Current/Constant Voltage. Charge procedure beginning with a fixed current followed by a transition to constant voltage. The voltage clamp from constant current to constant voltage is applied when the temperature compensated maximum voltage is reached.
Corrosive	The characteristic of a material (e.g., sulfuric acid) which allows it to gradually destroy some other materials it comes in contact with.
Crimp	To attach a connector to a wire or cable by using a special tool which compresses part of the connector tightly around the wire.
DC	Direct Current
Depth of Discharge (DOD)	The level of discharge measured as a percentage of total battery capacity.
Discharge Voltage Specification	A discharge voltage of 10.50 volts at 100% DOD for C/3 discharge. Minimum voltage of limiting module triggering end of discharge. Eighty percent Depth of Discharge is recommended for maximum life.
DOT	Department of Transportation
Duty Cycle	The ratio of ON time to total operating time.
Electrolyte	The mixture of sulfuric acid and water that is in the battery module.
ELSI	Electrosource, Inc.
EPCRA	Emergency Planning and Community Right-to-Know Act
Fahrenheit (F)	The international thermometric scale measurement of temperature where the freezing point of water is 32°F and the boiling point is 212°F. $T_f = 1.8T_c + 32$

Glossary

Finishing Charge	A method of charging the battery module which restores the cells to equal voltages by applying a period of low-level constant current. Voltage is allowed to float and rise freely during this phase.
Gassing	All valve regulated lead acid batteries will vent gas and vapor if overcharged.
Hz	The symbol used to represent a measurement of frequency in hertz.
I_f	Finishing Current
I_s	Initial Current
Limiting Module	Battery meeting voltage specifications necessary to trigger Voltage Clamp. Always the first module to meet Discharge Voltage Specification on discharge. For multi-step charge, the limiting module is usually the last module to reach Charge Voltage Specification.
Module	Synonymous with battery.
MSDS	Materials Safety Data Sheet. See Appendix C.
Multi-Step Standard Charge	Electrosource recommends this charging procedure for charging batteries in strings (battery packs). This charge algorithm consists of sequential constant current charge phases, each subsequent phase is half the current level of the previous phase. Voltage Clamp on limiting module triggers clamp for transition to incrementing phases. The Limiting Module for the Multi-Step Standard Charge is the last module to reach 14.25 (temperature compensated). There is also a maximum voltage per step of 15.5 volts temperature compensated in order to prevent damage in the event of a very low battery or large range of capacity in a battery pack. The final charge phase current is specified for each battery - consult battery specification for appropriate data.
NFPA	National Fire Protection Association

NFS	National Fire Safety
NIOSH	National Institute for Occupational Safety and Health
OSHA	Occupational Safety and Health Administration.
Pack Balance	Condition of near equal delivered discharge capacity from each module in a series pack. A pack is balanced if the measured voltage difference under load between the highest and lowest modules is less than 0.5V at 100% DOD of a constant current discharge at a C/3 rate. State of balance should not be determined from a charge cycle.
Pack Voltage	Sum of all individual module voltages arranged in a series configuration between two measuring nodes. Multiple series arranged in parallel between two measuring nodes will have the same voltage for each series between defined measuring nodes.
Pressure-relief Valve	A valve located on the battery module that vents excessive gas buildup in case of accidental overcharge.
psi	Pounds per square inch
RCRA	Resource Conservation Recovery Act
RGA	Returned Goods Authorization
Ripple	Component of alternating current superimposed on the normal DC output of a battery charger. This value should be 5% or less. Excessive AC ripple current causes heating of the modules, increases the corrosion rate, and increases water loss from the electrolyte. Check the factory specification for the charger to be used.
State of Charge (SOC)	Capacity remaining in battery as a percentage of nameplate capacity.
Stored Battery	An individual battery that is not fresh off the manufacturing floor. A battery that has been sitting in storage for a period of time.

Glossary

Temperature Compensation

Altering the clamp voltage level used to complete the charge of a battery using a specified formula based on initial battery temperatures.

Terminal Protectors

Plastic covers that slip over the battery module terminal to protect the terminal from damage during handling and shipping.

Thermal Runaway

A condition during battery charging at constant voltages wherein temperature increase leads to increased charging current. This in turn increases the temperature further and a runaway situation results, destroying the battery unless the current is limited appreciably.

Voltage Clamp (V_c)

A voltage clamp is reached when the temperature compensated voltage specification on the limiting module is reached.

Volt (V)

The potential difference between two points. The symbol used to represent volts is V.

Valve-Regulated Lead-Acid (VRLA)

All HORIZON® batteries operate as sealed, maintenance free modules. No water or electrolyte is required to be added during the designed lifespan. However, all sealed valve regulated lead acid batteries are subject to venting if overcharged. The level of venting is a function of voltage and current level. HORIZON® battery valves are adjusted for an approximate pressure release of 1.5 psi. Individual module balancing Battery Management Systems are highly recommended. A Battery Management System will manage charging and discharging to insure this. Since all sealed batteries have a designed amount of electrolyte, it is important to minimize gassing. This is easily accomplished by designing and verifying a proper charge procedure.

APPENDIX C

**ADVANCED LEAD ACID BATTERY TEST PLAN
SACRAMENTO MUNICIPAL UTILITY DISTRICT**

ADVANCED RESEARCH PROJECTS AGENCY GRANT NO. MDA972-93-1-0025

**Revision 0
March, 1995**

ADVANCED LEAD ACID BATTERY TEST PLAN
Revision 0

I. PURPOSE

This Test Plan addresses the testing to satisfy the Advanced Lead-Acid Battery Test Project funded by ARPA Grant No. MDA972-93-1-0025. The project involves field testing of approximately 318 modules of the first battery model manufactured by Electrosource, Inc. in about fifteen selected Sacramento Consortium vehicles prepared for use of this battery model. This field test also involves laboratory testing of battery modules as they arrive and as battery packs in the vehicles.

II. REFERENCES

- A. Advanced Research Projects Agency Grant No. MDA972-93-1-0025
- B. Contract No. F-397 - UC Davis
- C. Work Order No. 701258
- D. United States Advanced Battery Consortium (USABC) Electric Vehicle Battery Test Procedure Manual Revision 1, dated July, 1994.

III. TEST CRITERIA

- A. Selected battery modules shall be characterized prior to installation to determine capacities at the C/1, C/2, and C/3 discharge rates following receipt (C/3 rate), and following charging to manufacturer specification (C/1 and C/2 rate).
- B. Each battery module shall be inspected on receipt for general condition, and its serial number recorded, its weight recorded, its as-received voltage recorded, and any other identification assigned at that time.
- C. Laboratory testing shall generally be in compliance with Test Procedure No. 2 of the USABC Test Procedures Manual, "Constant Current Discharge Test Series". Data acquisition and reporting shall meet the applicable requirements for "Performance Test Reporting" (refer to Appendix B of USABC Manual).

IV. PLANNED SCOPE AND RATIONALE

- A. The Horizon battery test program, i.e., the Advanced Lead Acid Battery Test and Demonstration Project, will include laboratory testing at UC Davis's Electric Vehicle Power Systems Laboratory, supplemented by spot test and monitoring by SMUD and McClellan AFB personnel, as well as field testing on a continuous basis by SMUD and McClellan personnel.
- B. Test vehicles are to be of a variety of configurations, as well as in a variety of services. Although not necessary for adequate battery testing, the variety of vehicles involved will lend variability to the project that will provide for verification of specified and/or expected battery performance.

The following vehicle and battery configurations are planned:

1. Light duty commuter vehicles with a single string of battery modules in series (Solectria or other light duty passenger sedan).
 2. Medium duty vehicles with two parallel strings of battery modules in a moderate voltage (120 nominal end terminal voltage) and parallel drive system vehicles (Electricar shuttle busses).
 3. Light duty vehicles with a single string of battery modules in series in a high voltage (240 volt nominal end terminal voltage) series battery pack (General Motors S-10/S-15 pickup).
 4. Light duty vehicles with two parallel strings of battery modules in series to form one pack powering a single drive train (General Motors S-10/S15 pickup).
 5. Medium duty vehicles with two parallel strings of battery modules in a moderate-to-high voltage parallel battery pack arrangement (G-Vans).
 6. Medium duty vehicles with "series/parallel" battery strings in a moderate-to-high voltage battery pack (G-Vans.)
 7. Light duty composite based vehicles with a single string of battery modules forming a moderate voltage (120 to 144 volt) series battery pack (Horlacher/Electricar pickup and commuter prototypes).
- C. Charging control systems are to be evaluated for their effectiveness, necessity, and other factors relative to life and life cycle cost of Horizon and other similar batteries.

- D. An inherent aspect of this test project will be the evaluation of terminal connector designs used for the test batteries. The Radsock connector manufactured by Konnectek is specified by Electrosorce for use on their Horizon battery. Variations of this connector, or alternatives may be used. Performance of the connectors will be assessed and abnormal conditions recorded and reported.
- E. Vehicles will be equipped with data acquisition equipment as available within the Sacramento Consortium. These systems will include, but not necessarily be limited to the following:
- 1) Badicheq control and monitoring systems will likely be installed in all packs. For direct comparison, some vehicles may be tested with this system to quantify it's effectiveness;
 - 2) Kilowatt-hour and Ampere-hour meters;
 - 3) Campbell CR-10 based data acquisition system;
 - 4) Fluke Data Bucket based data acquisition system;
 - 5) Detection Limit Technology, Inc., Integrated Data Logging and Management Systems.
- F. Vehicle usage is monitored periodically, with usage data recorded in a SMUD data base. This usage data will supplement other test data.
- G. As available, charge and discharge cycle efficiencies will be calculated and reported. A variety of charging systems may be used for this project due to the variety of vehicles and drive systems involved, and the resultant variation in battery pack configurations. Charge and discharge cycle efficiency information is valuable regardless of the charging technology used.
- H. Primary performance specifications of the Horizon batteries are cycle life and usable capacity. Secondary performance specifications will include specific power, self discharge, maximum and minimum charge rate, and other performance characteristics no described as primary performance specifications.

Field and laboratory testing will be used to measure battery performance as necessary to determine the level of conformance to predicted or otherwise stated primary performance specifications. This testing will be performed periodically throughout the project.

Field and laboratory testing may be used to measure battery performance relative to secondary performance specifications. Testing for conformance with secondary performance characteristics may be performed at irregular times in the life of the various battery packs, as budget and other considerations allow during the project.

V.

DOCUMENTATION

- A. Test documentation shall include battery serial number(s).
- B. Test reports shall be completed for each test cycle, and submitted to SMUD Electric Transportation upon completion.
- C. Test results for each quarter shall be summarized and submitted within ten working days following the end of the quarter.

APPENDIX D

**REPORT ON RETROFIT
OF A SOLECTRIA FORCE
WITH HORIZON BATTERIES**

**Sacramento Municipal Utility District
Electric Transportation Department**

I. Introduction:

Advanced electric vehicle batteries can greatly enhance the acceptance of EVs by providing greater range, acceleration, and life. Maintenance-free batteries are desirable, especially in fleet operations, because of reduced maintenance costs.

The Electrosorce *Horizon* battery was developed specifically for EVs to provide a long life to a high energy sealed lead acid battery. A pilot production facility in San Marcos, Texas was built in 1993 to manufacture these batteries. The *Horizon* battery has been extensively tested in laboratories with very favorable results on the following attributes:

- 27% greater specific energy than conventional flooded batteries
- 3.5 times specific power of conventional flooded batteries
- 2.5 times longer cycle life than conventional flooded batteries
- short recharge time
- sealed, requiring no watering
- low cost of raw materials

A battery pack with these attributes would improve the range and performance of existing electric vehicles. While lab bench testing of batteries is useful, field tests with high use vehicles is a more realistic way to verify the performance of the batteries.

The Sacramento Municipal Utility District (SMUD) endeavored to test these batteries in a variety of EVs in the fleet. One of these vehicles is a 1993 Geo Metro Force previously converted by Solectria Corporation with 144 volts of flooded lead acid batteries and purchased by McClellan Air Force Base. The vehicle, having driven 1964 miles on its original battery pack, was converted to Horizon batteries in August , 1994.

II. Horizon Battery Pack Specifications

The battery pack is made up of 12 Horizon Model 12N95 advanced lead acid batteries. The outside dimensions of each battery, including their recessed battery terminals, are:

- Length 30.304" (769.8 mm)
- Width 5.05" (128.3 mm)
- Height 5.215" (132.6 mm)

Each battery weighs 60 pounds (27.5 kg). The weight of the battery pack is 720 pounds (330 kg) not including the weight of the battery containment box, cables or ventilating fans. Each battery is rated at 12 volts and has a capacity of 95

amphours at a C/3 rate (1.14 kWh). The total pack is rated at 13.7 kWh at the C/3 rate. A diagram of the battery pack is shown in Figure 1.

The Horizon Model 12N95 was designed with terminal posts on each end of the battery that do not extend above the top surface of the battery. These terminal posts were designed to fit a 10.3mm Radsok terminal connector crimped to a 2/0 cable. This connector is made to slide on and off the terminal easily and maintain good electrical contact. The 90° connector (P/N 103-0004-2X) was purchased from KONNEKTECH, 34230 Riviera Dr., Fraser, MI 48026, (810) 294-7400. For a series string of 12 volt batteries, one connector is required for each terminal. A Safe-mate crimper (Model #94283 or #94285) was used to crimp the terminal connectors onto 2/0 copper wire. The crimper was obtained from a source recommended by Mauldin Industrial Park at (803) 967-2615. The connectors can also be ordered from KONNEKTECH with the cables factory crimped including insulating boots.

III. Battery Containment Box Design

A diagram of the front and rear battery boxes is provided in Figure 2.

Front Battery Box:

The front battery box was used in its original location, however, spacers were added to adjust the height of the box to allow for 2 layers of Horizon batteries. The sides and bottom are constructed of 14 gauge aluminum sheet metal welded together. The box is mounted under the hood and runs the full width of the vehicle from left strut tower to right strut tower. The box lid is made of 1/16" fiberglass and is bolted to the box with a solid 1"x1" PVC spacer between the box and lid leaving a 1" gap at the end of each spacer. A 4" brushless exhaust fan is mounted in the lower left rear of the battery box. A heating blanket is located on the bottom of the box. This blanket is only active when 220 vac is applied (same for the exhaust fan). The blanket is controlled by a thermostat to come on when the temperature dips below 60° F. The 4 batteries are mounted transversely in 2 layers of 2 batteries. 1/4" PVC spacers are located between battery layers for ventilation, and extra dense 1" foam rubber is placed around all sides and tops of batteries.

Rear Battery Box:

The original rear battery box in the rear deck of the hatchback Geo Metro was completely removed and replaced with a new battery box designed and built by Solectria. The battery box is sized for eight batteries in a transverse orientation leaving about 1 1/2 inches excess space on every side which allows the necessary clearance for cable strain relief and for ventilation.

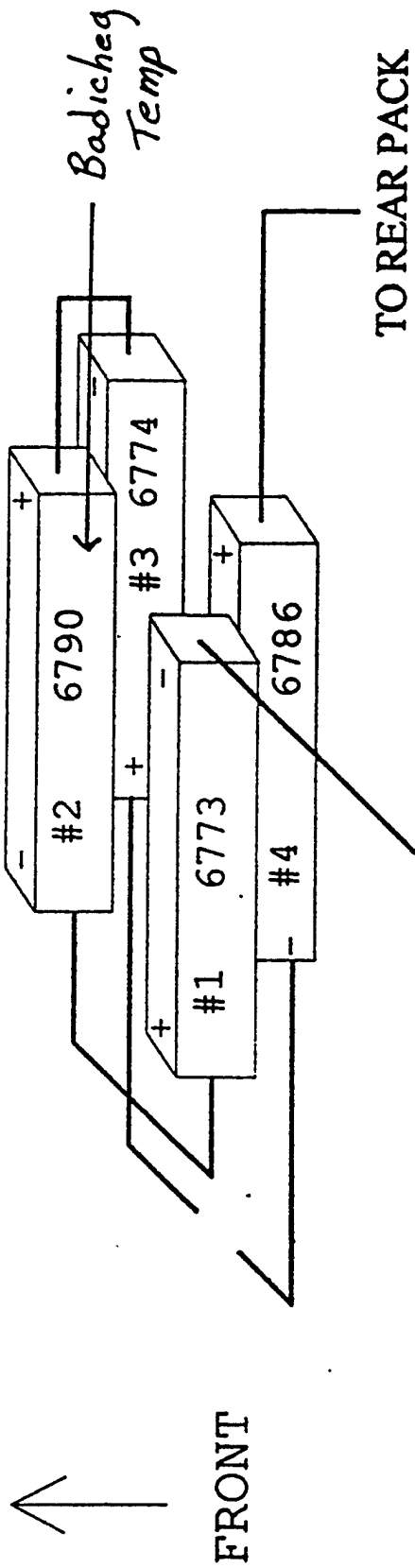

AS OF 01/03/96 TO MAIN FUSE

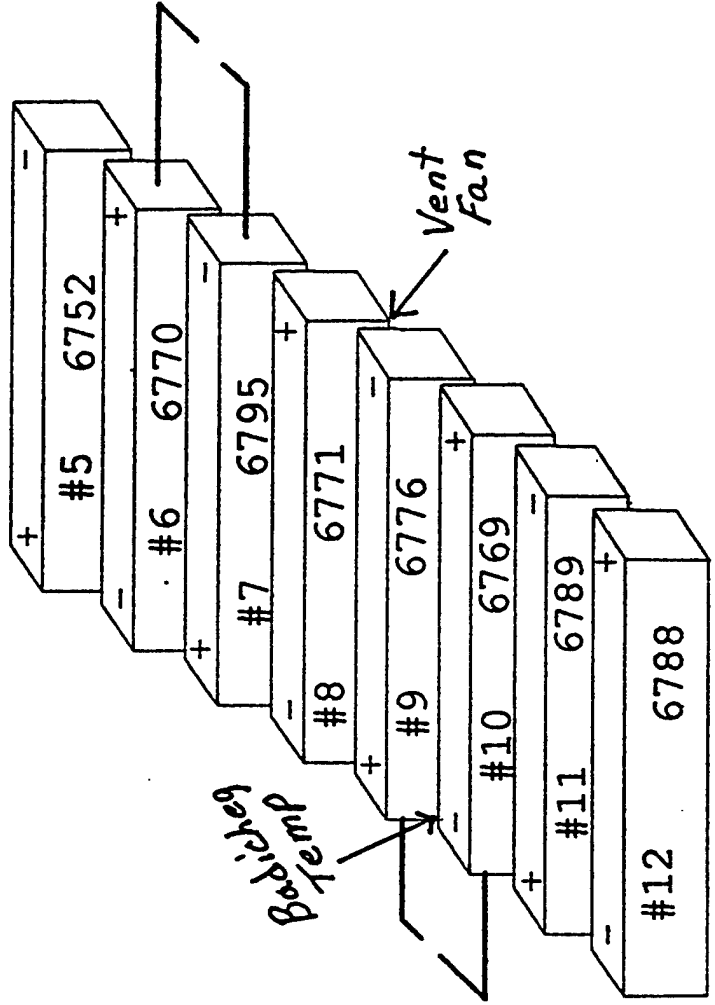
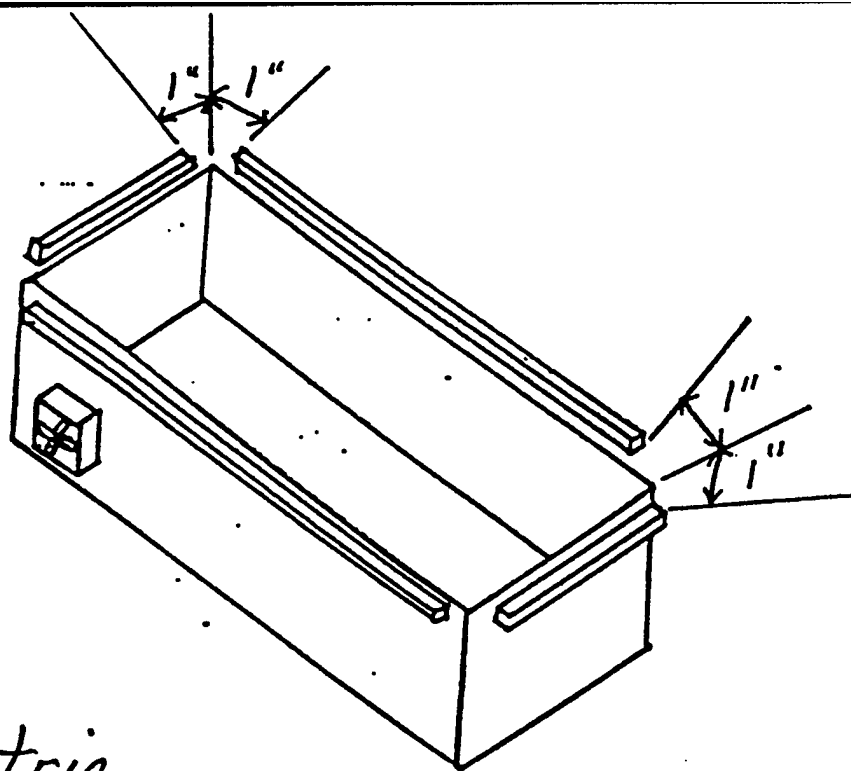

Figure 1. M01 Slectria Battery Pack Configuration



FRONT BOX

FRONT

Figure 2.

101-Solectria

Battery Box Configuration

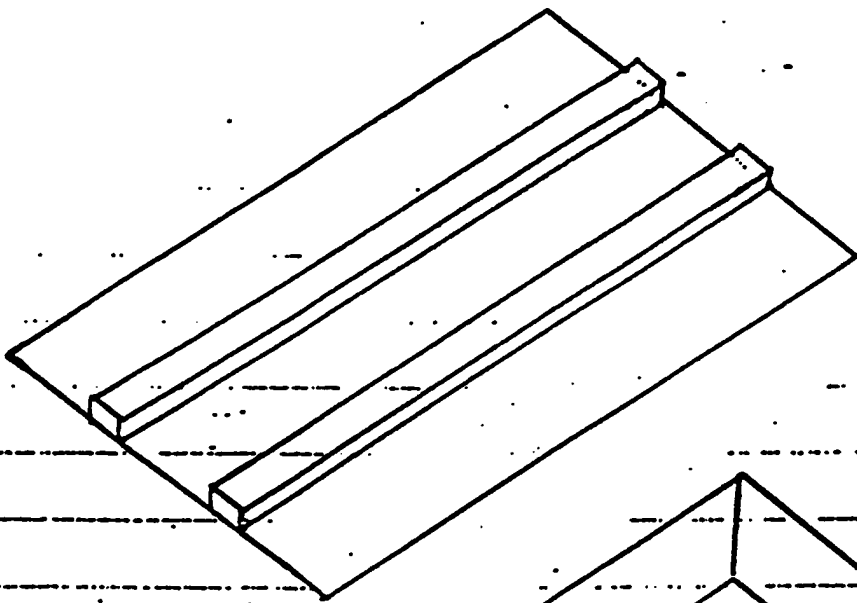

Rear Box

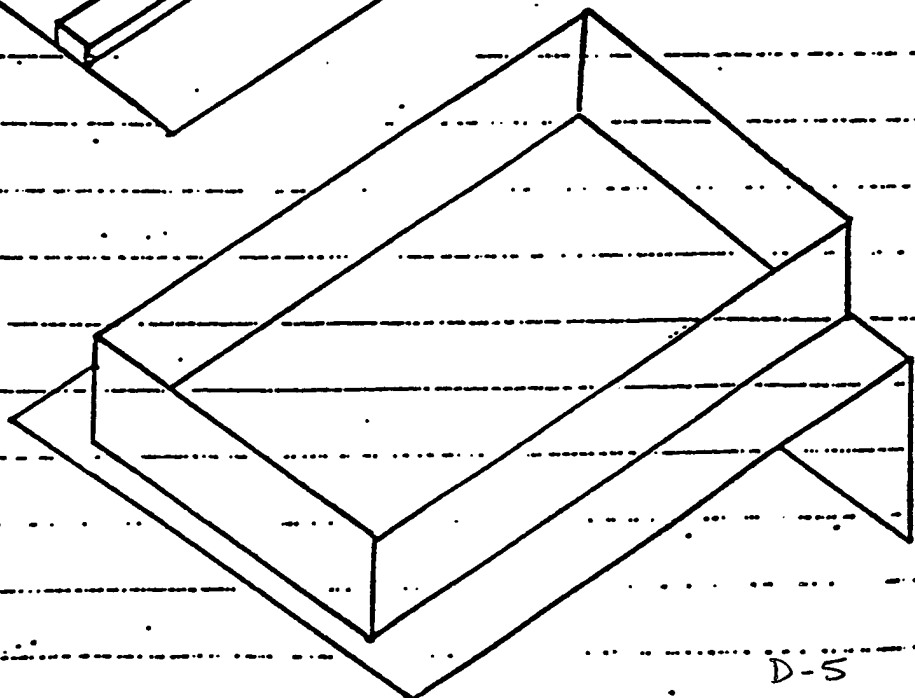

FRONT

The base of the box is 1/8" aluminum sheet metal, mounted behind the front seat and extends to the rear of the vehicle. The sides are 14 gauge aluminum sheet metal welded to the base. The top is 14 gauge aluminum sheet metal, reinforced with 2 each 2"x1"x.065 rectangular tubing running front to rear and is bolted to the box. Foam weatherstripping is glued to the top edge of the box to seal it. The top, sides and base are covered with thin black carpet. In the center of the base is a 4" brushless exhaust fan (between batteries #8 and #9) that vents out under the vehicle and is on only when 220 vac is applied. The 8 batteries are mounted transversely in a single layer. Small strips of extra dense 1" foam rubber are used to space the batteries, but are not intended for insulation purposes. 2 each heating blankets are used to cover the bottom of the box. The blankets are only active when 220 vac is applied. The blankets are controlled by a thermostat to come on when the temperature dips below 60° F. The rear box is approximately 6"H x 35"W x 42"L. Photos of the rear battery box are provided in Figures 3 through 5.

IV. Temperature Sensors

The Badicheq system has two temperature sensors, one in each battery box. The front box sensor is located between batteries #1 and #2. The rear box sensor is located between batteries #8 and #9.

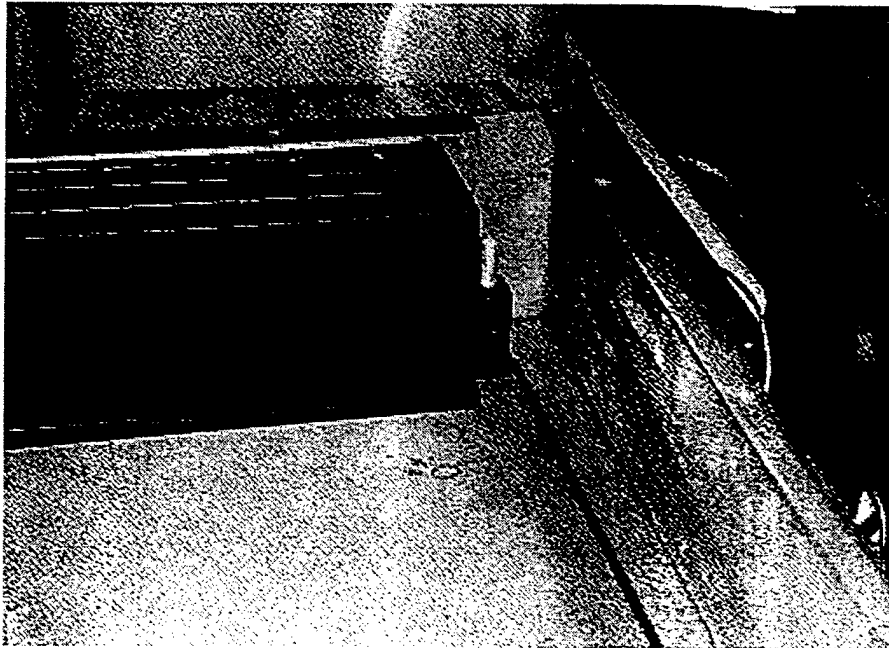

Figure 3. Horizon battery as it fits in the battery containment box in the rear of the Solectria Force. Terminal is below the top of the battery.

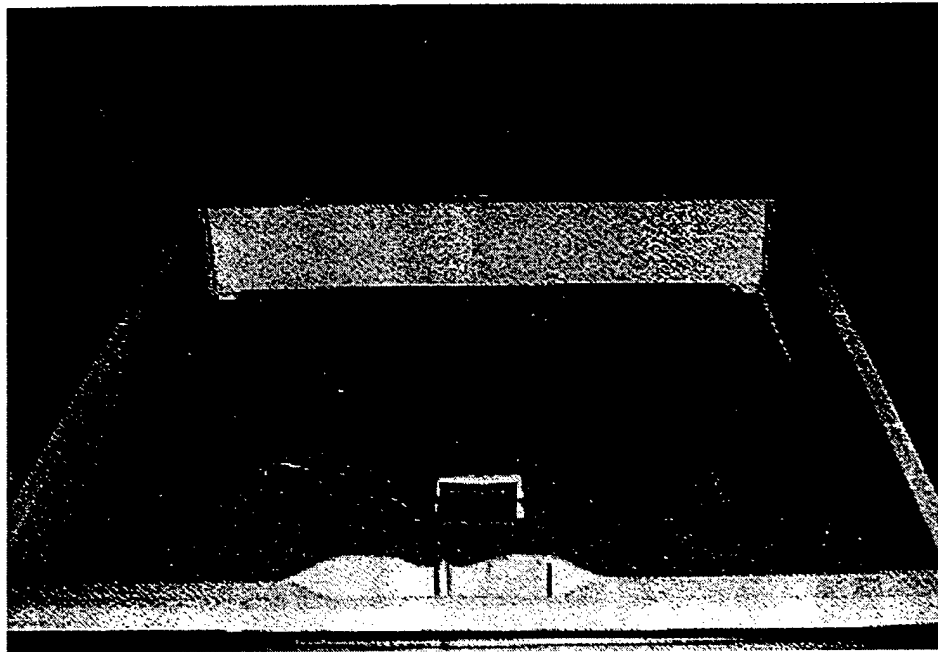

Figure 4. Rear battery containment with ventilation fan installed through the floor. Fan turns on when charging begins.

V. Charging System

A system was needed to properly control the end of charge and equalize the pack when charging.

Electrosource recommends use of a battery charge management system with their batteries. The Badicheq Charge and Discharge Equalization System was chosen and acquired through Drake Associates, 490 Wheeler Rd, Ste 100, Hauppauge, NY 11788, (516) 666-1354. This system has been used on 50 systems in the US and over 300 gel-cell battery packs in Europe.

The Badicheq battery management system ordered for the vehicle was programmed for the exact number and location of batteries, the type of battery and the size of the shunt being used. The system was then installed according to the manufacturer's instructions and with the assistance of the distributor's technician. The Badicheq system monitors each individual battery voltage every 50 milliseconds during discharge and charge. Two temperature sensors, one in each battery box, monitor the pack temperature. By use of a digital display the Badicheq system warns the driver of a low battery.

The Badicheq also controls the charger to prevent overcharge, and provides an equalizing charge to individual batteries. The purpose of the system is to prevent any damage to the batteries and to allow full utilization of the battery pack during its life. Each positive battery terminal is fitted with an 18 gauge wire for communication to the Badicheq and for additional equalizing charge current.

The charger must be able to accept the signal of the Badicheq system which signals the charger to reduce its current when the first battery module reaches the temperature compensated clamp voltage of 14.25 volts. The charger must be a programmable switchmode charger that will accept a pulse width modulated (PWM) signal. A C1/CV/C1 charge profile was recommended with the charge current to the batteries beginning at 38 amps. A charger capable of this current level was not available at the time of installation.

The charger chosen for the Solectria is a Mentzer 3kW charger operating off of 208/240 volt 40 amp service. The charger output is approximately 16 amps during peak charging and it accepts the signal from the Badicheq to ramp down the current at the appropriate time. A new cord and plug assembly was made for this charger and the digital AC kWh meter previously installed by SMUD was modified to work with 208/240 voltage rather than 110 volts.

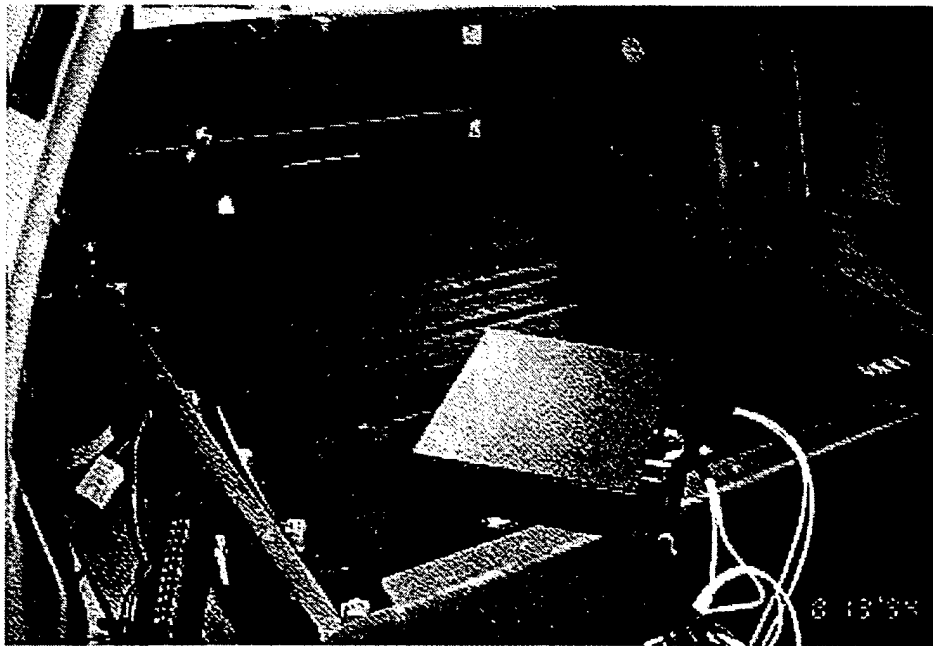

Figure 5. Eight Horizon batteries in back of Solectria Force with Badicheq Battery Charge Management System resting on top.

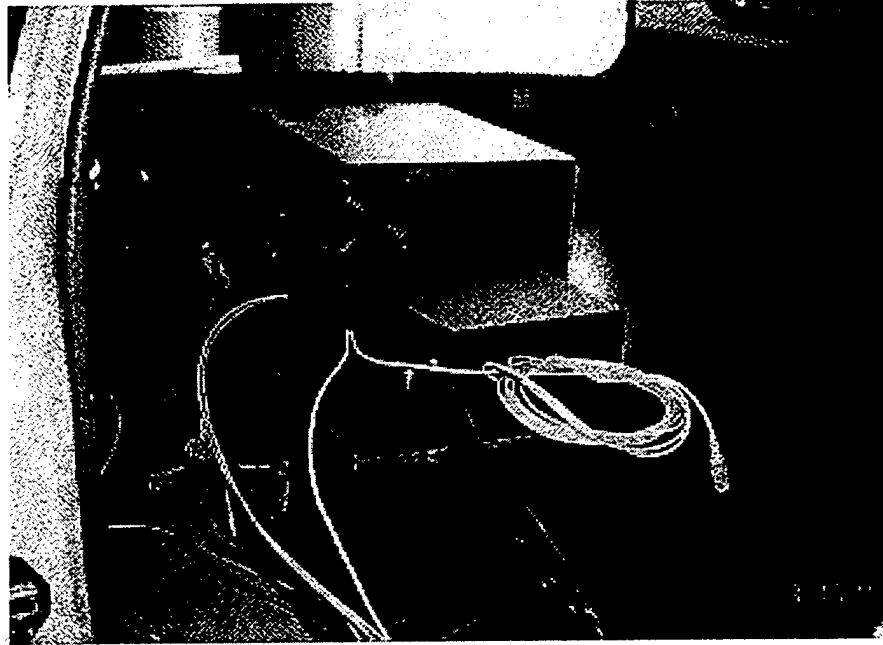

Figure 6. Charger and Badicheq installed on top of battery box in Force

VI. State of Charge Indicator

A key benefit of the Badicheq system is the accuracy of its state of charge indicator. The state of charge is calculated by the Badicheq software constantly checking the voltage, current, and temperature. This figure is displayed on the digital LED display provided with the Badicheq was mounted in front of the "gas gauge" section of the dash. The number displayed as "FULL" is about 80, so while the vehicle is being driven this capacity gauge counts down from 80 to 0. The starting number of 80 is used as a reminder that the driver is only taking 80% of the capacity from the battery, so the vehicle can be driven from 80 down to zero. The Horizon Battery 12N95 is at 80% DOD at 11.25 volts. At this point the Badicheq display will read "HALT" and the driver knows that it is time to charge the car.

Badicheq bases its starting capacity on the capacity of the lowest performing battery module in the pack. When the Badicheq is first installed, a calibration cycle is done. The vehicle is discharged into a load bank at approximately the C-5 rate (95 ah X 80% DOD / 5 hours is 15.2 amps) until one module reaches 11.6 volts. At this point, the digital SOC display will read "E-6". The discharge is terminated and the car is put on charge.

From this point on, the Badicheq computes the capacity of the battery pack based on the capacity of this lowest performing battery. After driving the car

about twenty more cycles bringing them up to full capacity, another calibration cycle is done and a calibration is repeated about every 6 months thereafter. The digital display also provides other information about the battery pack through the use of error codes. Following are the most pertinent codes:

- FULL charging complete
- HALT 80% DOD of lowest battery module - time to charge
- E-6 low battery module voltage (100% DOD or below 11.25 volts)
- E-25 low battery pack voltage (below 135 volts)
- P-1 phase one of charging - or regen braking active
- E-30 overcharge has occurred - (this has appeared sometimes when the car was left on charge for several days - the amount of overcharge was insignificant)

The amphour counter originally in the vehicle remains in the mid dash area. This counts up to about 75 amphours and then counts down when charging to a minus number. The amphour counter "zeros out" when the car is driven after a full charge.

VII. Performance Characteristics

Total weight of the vehicle with the new battery pack is 2210 pounds. The vehicle has less sway with the lower center of gravity than before the retrofit. After testing the vehicle on short trips, the vehicle was charged and then driven over hilly terrain with stop and go traffic. A total of 85 miles was achieved when the battery pack was discharged 89.2 amphours. Acceleration throughout the discharge cycle was significantly improved over the previous battery pack.

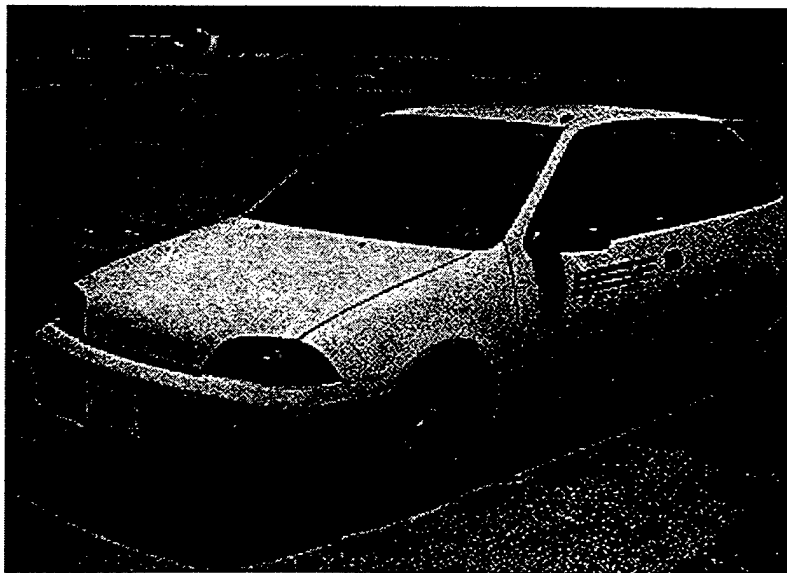

Figure 7. Solectria Force with Horizon batteries installed.

VII. Data Acquisition Results

In addition to calculating the state of charge and managing the charging of the batteries, the Badicheq system also keeps a statistical record of each charge and discharge cycle up to 256 cycles, after which it begins to write over the first cycles saved. The statistical data is automatically collected in the Badicheq's memory and can be viewed from a personal computer using the DOS based software provided with the Badicheq. By connecting an RS232 cable to the 9-pin port on the Badicheq, the operator can view real-time and historical data on the car and save files when needed.

A saved file will capture a graphic display of the last cycle whether it is a charge or discharge. The files are already labeled with a date and cycle number, therefore, it is most helpful to name the file with a three digit vehicle identifying number and the mileage from the odometer ending with a "D" for discharge and a "C" for charge.

Following is a discharge chart from the vehicle when driven in city traffic about 70 miles. The chart graphs the voltage of the best battery, the worst battery and an average battery in the upper plot and graphs the discharge current in the lower plot.

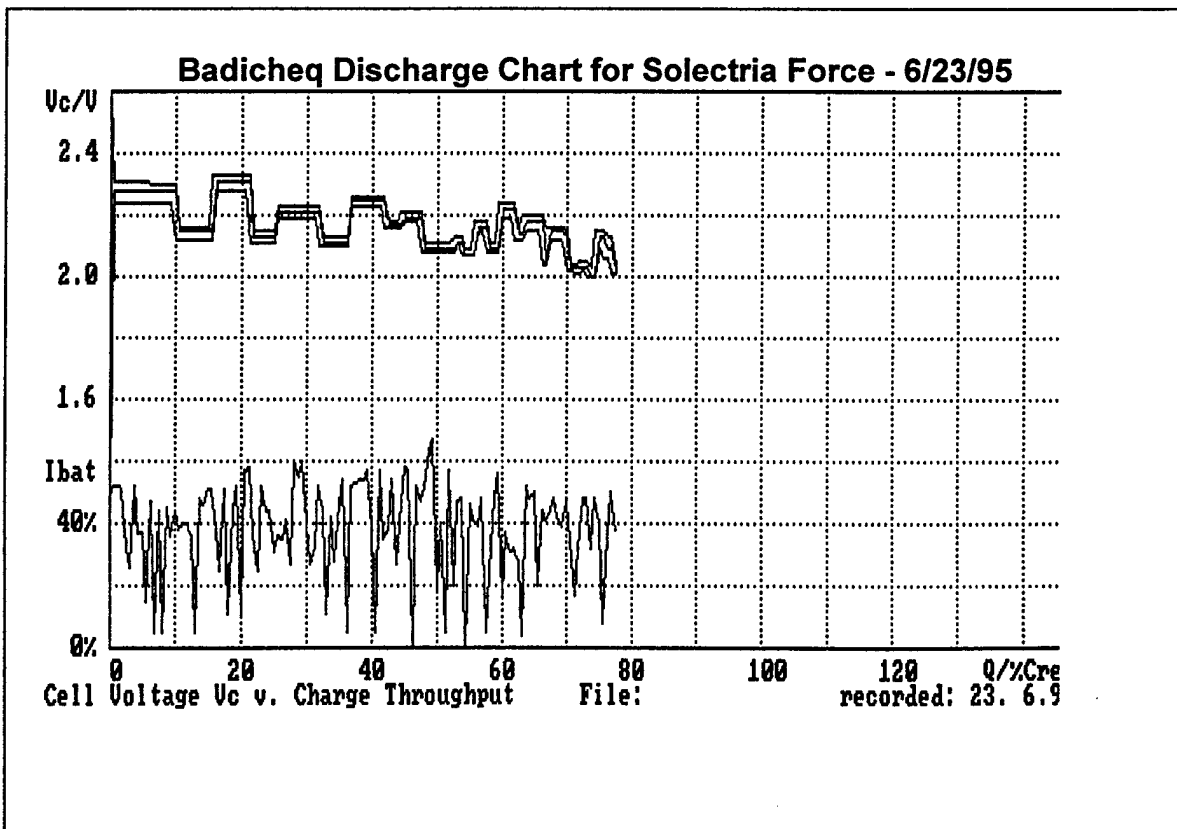

Figure 8 Badicheq discharge chart

The pack was discharged almost 80% of its capacity as can be seen by the end point of the dynamic cycle tracked along the horizontal axis. The current trace indicates that the average discharge current was about 30% of the current limit for the vehicle. For the Solectria Force, discharge current is limited to 160 amps, so the 30% mark is approximately a 48 amp draw.

The upper plot corresponds with the volts per cell of the best battery, the worst battery, and an average battery. Measurements are taken every 50 milliseconds, but the data and voltage plot is only updated about every 10 minutes during the early part of the discharge resulting in a voltage plot that appears erratic early in the discharge. Towards the end of the discharge (based on capacity) the Badicheq updates the data more frequently, and we can see a more accurate glimpse of the state of the battery voltage. Having started out at 2.3 volts per cell (13.8 volts) on the left, they are at about 2 volts per cell (12 volts) at the end of the discharge.

The following table of actual Badicheq data output shows the voltages of the six lowest batteries in the battery pack during this discharge cycle. This type of data is held in memory and can be accessed at any time. The cycle number is displayed down the column at the left. All odd cycle numbers are charges and all even cycle numbers are discharges. The voltage history, Figure 9, is stated in volts per cell as are the graphs. Reading the top line, Cycle #45, you can see that battery module #2 has reached 2.441 volts per cell at the time the reading was taken which was at the end of a charge cycle. A 12 volt battery has 6 cells, so the battery reached 14.6 volts (6 X 2.441 volts). This is the desired voltage for a fully charged Horizon battery. At the end of the previous discharge (Cycle #44), the same battery #2 (4th from the left) was at 1.982 volts per cell or 11.9 volts.

VOLTAGE HISTORY File: 0050623C recorded: 23. 6.94										
Cycl	Ba W0	Ba W1	Ba W2	Ba W3	Ba W4	Ba W5	Ba Best	Avg	QM	T
45!	2:2441	9:2330	7:2324	10:2314	4:2307	3:2307	11:2291	2314	88	1
44!	1:1972	4:1979	3:1979	2:1982	11:2014	10:2014	7:2027	2005	66	0
43!	5:2399	9:2314	7:2314	10:2304	12:2294	8:2294	1:2281	2301	88	1
42!	11:2073	5:2076	10:2080	6:2080	12:2083	8:2086	4:2099	2086	65	0
41!	1:2486	3:2438	4:2425	9:2389	7:2386	10:2379	5:2317	2376	53	1
40!	2:2050	3:2054	1:2054	12:2057	11:2060	5:2060	7:2080	2060	25	0
39!	7:2184	9:2180	12:2174	8:2174	10:2171	6:2171	1:2141	2164	11	0
38!	1: 0	1: 0	1: 0	1: 0	1: 0	1: 0	1: 0	0	100	1
37!	4:2441	5:2412	3:2405	1:2366	7:2363	10:2350	11:2307	2356	75	1
36!	1:2027	10:2031	6:2031	5:2031	3:2031	12:2034	7:2041	2034	53	0

Figure 9 Badicheq voltage history

Following is a chart showing the charge cycle which followed the Cycle No. 44 discharge noted above. When the first battery reached over 2.4 volts per cell (14.4 volts), the Badicheq signaled the charger to ramp down the current slowly and end with a low amperage finish charge. The batteries continue to float at around 2.4 volts per cell until charging is terminated.

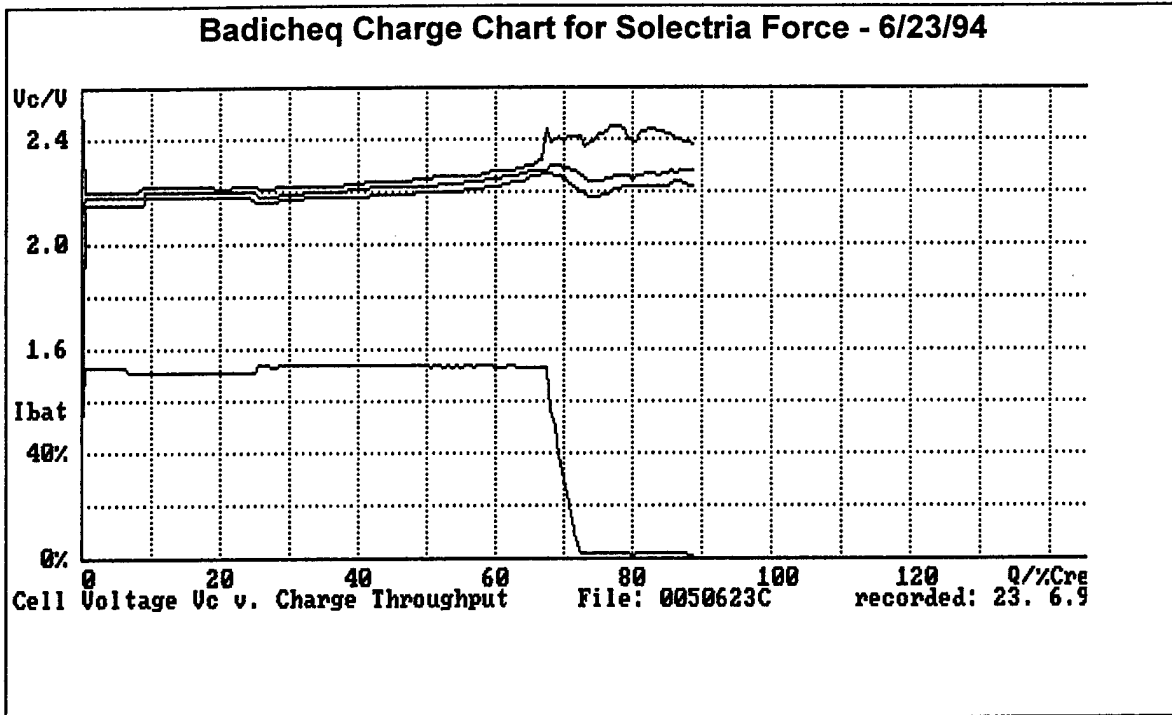

Figure 10 Badicheq charge chart

VIII. Conclusions

The Solectria Force retrofitted with Horizon batteries met our expectations in areas of range and exceeded our expectations in maintaining the same ability to accelerate throughout a discharge cycle. Evidence on the cycle life performance of the pack is inconclusive at this time.

APPENDIX E

**REPORT ON RETROFIT
OF A G-VAN TO
HORIZON BATTERIES**

**Sacramento Municipal Utility District
Electric Transportation Department**

I. Introduction:

Advanced electric vehicle batteries can greatly enhance the acceptance of EVs by providing greater range, acceleration, and life. Maintenance-free batteries are desirable because of reduced maintenance costs.

The Electrosource *Horizon* battery was developed to provide a long life to a high energy sealed lead acid battery, specifically for EVs. A pilot production facility in San Marcos, Texas was built in 1994 to produce these batteries. The *Horizon* battery has been extensively tested in laboratories with very favorable results on the following attributes:

- 27% greater specific energy than conventional flooded batteries
- 3.5 times specific power of conventional flooded batteries
- 2.5 times longer cycle life than conventional flooded batteries
- short recharge time
- completely sealed, requiring no maintenance
- low cost of raw materials

Such a battery can significantly enhance the performance of electric vehicles. While lab bench testing of batteries is useful, field tests with high use vehicles is a more realistic way to verify the performance of the batteries.

The Sacramento Municipal Utility District (SMUD) endeavored to test these batteries in a variety of EVs in the fleet. One of these vehicles is a 1990 Conceptor G-Van previously equipped with 216 volts of flooded tubular lead acid batteries.

II. Horizon Battery Pack Specifications

The battery pack is made up of 36 Horizon Model 12N95 advanced lead acid batteries assembled in a series string of pairs of batteries wired in parallel. We call it a series/parallel pack for brevity. The dimensions of each battery are:

- Length 30.304" (769.8 mm)
- Width 5.05" (128.3 mm)
- Height 5.215" (132.6 mm)

Each battery weighs 60 pounds (27.5 kg). The weight of the battery pack is 2178 pounds (990 kg) not including the weight of the battery tray and cables. This replaces a battery pack weighing 2520 pounds. The stored energy is comparable to the previous battery pack and is summarized in the following table.

	number of cells	voltage of cells	Ah at C/3	total kWh in pack	weight (lbs)
Chloride 3 ET 215	36	6 V	191	41.4	2520
Horizon 12N95	36	12 V	95	41	2178

Table 1. Comparison of energy stored in G-Van with Horizon batteries.

The Horizon Model 12N95 was designed with terminals on each end of the battery that fit a 10.3mm Radsok terminal connector for 2/0 cable. This connector is made to slide on and off the terminal easily and maintain good electrical contact. For the series/parallel pack two types of connectors are needed. A 90° connector is used for the series connections and a 180° connector is used for the parallel connections. For a G-Van battery pack 36 of each type connector are needed. Connectors were purchased from KONNEKTECH, 34230 Riviera Dr., Fraser, MI 48026, (810) 294-7400. The batteries are connected in series/parallel/series configuration laid out according to the drawing below:

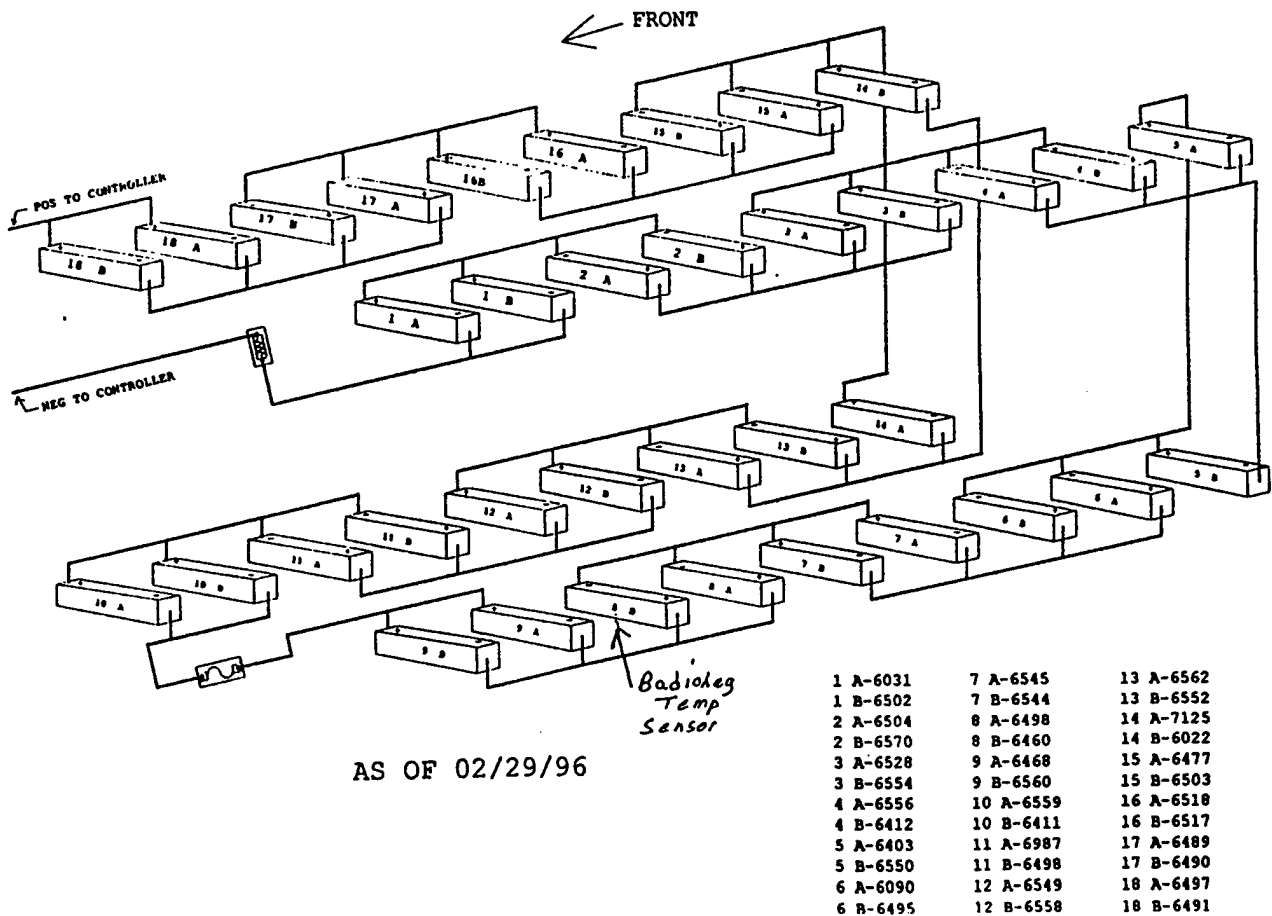

Figure 1. Series of 18 sets of two Horizon batteries connected in parallel.

III. Battery Containment Box Design

The original battery tray was removed and replaced with a new battery tray designed by Electrosorce and built by Industrial Trucking in New York.

The G-Van batteries are contained in a single battery box mounted under the vehicle. The box is roughly 60 inches long by 64 inches wide (the full width of the vehicle) and is 9 inches tall. The box is mounted 4" below the vehicle frame starting 18" behind the front wheels and ending 18" in front of the rear wheels.

The batteries are placed in the box in a transverse orientation in two layers, with a 1/2" to 3/4" space between layers and 1" between batteries. Each layer has two rows of batteries separated by a divider made up of 3 each 1 "x2.5"x1/8" rectangular tubes. The battery box frame is constructed primarily from 1"x2.5"x1/8" rectangular A36 steel tubing welded together. Upper and lower trays hold the batteries, with the upper trays made of 16 gauge Galvaneel steel and the lower trays 20 gauge. Reinforcement plates, gussets and mounting hardware are made from 1/2" steel plates. A photo of the battery box with batteries installed is provided in Figure 2.

The batteries are held in place by a retaining structure that passes over the top of the batteries and anchors to the battery tray. This structure uses 11 gauge clamp brackets and 1/4" bolts.

There is no top or final enclosure. When the vehicle is driven, ambient air blows between the frame and the top layer of batteries. The lower layer of batteries is vented through 1/8" x 2" slots between frame side tubes, roughly 5" from the bottom. Because of the open design of the battery box, passive ventilation around the batteries keeps them cool during charging. However, the batteries are exposed to cold ambient temperatures in the winter. There are no ventilation fans, thermal blankets or insulation around the batteries and there is no thermal management system for heating the batteries.

IV. Temperature Sensor

The vehicle is equipped with the Badicheq charge management system. This system monitors and records pack maximum and minimum temperature during an operating cycle (either charge or discharge). The G-Van uses a single temperature sensor located between batteries #8 and #9 (see Figure 1).

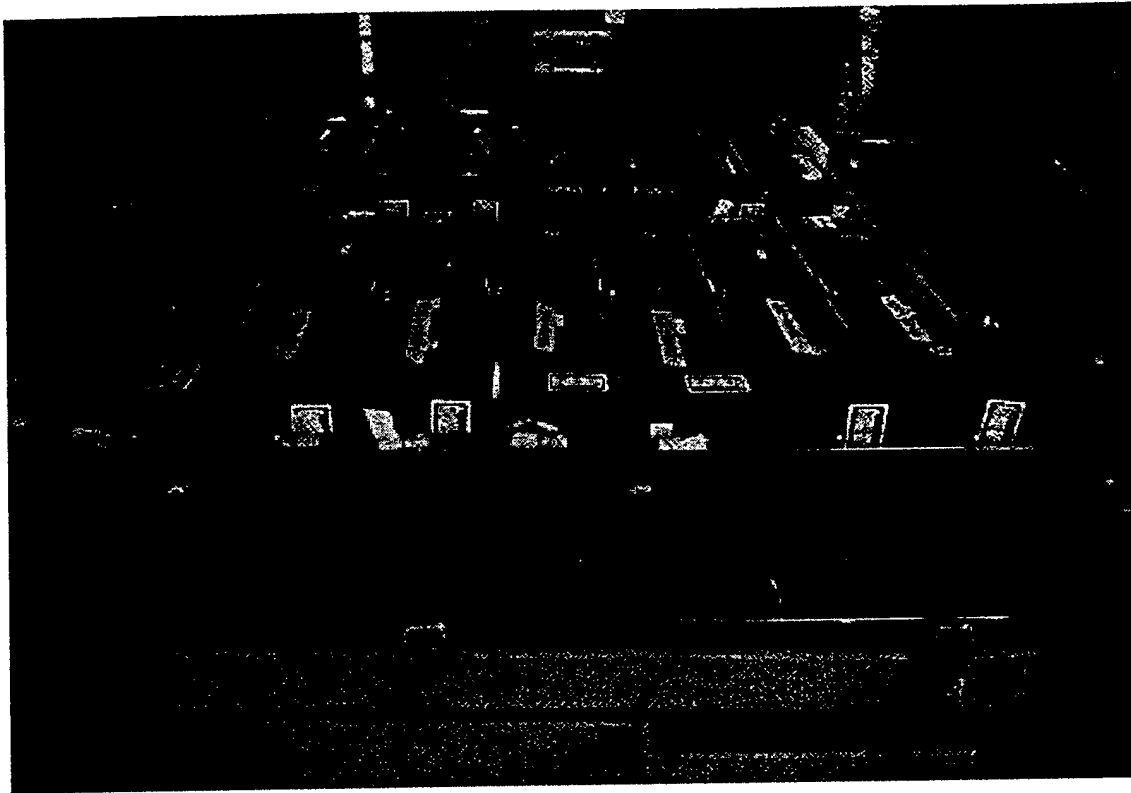

Figure 2. Thirty-six Horizon batteries in new battery tray ready for installation.

V. Charging System

A system was needed to properly control the end of charge and equalize the pack when charging. A battery charge management system is recommended for use with any sealed lead acid battery, including the *Horizon* batteries. The Badicheq Charge and Discharge Equalization System was chosen and acquired through Drake Associates, 2941 Sunrise Hiway, Islip Terrace, NY 11752, (516) 277-6700.

The Badicheq battery management system was installed according to the manufacturer's instructions. The Badicheq system monitors individual batteries on discharge, warns the driver of a low battery, monitors the batteries on discharge, controls the charger to prevent overcharge, and provides an equalizing charge to individual batteries. The purpose of the system is to prevent any damage to the batteries and to allow full utilization of the battery pack during its life. Each positive battery terminal is fitted with an 18 gauge wire for communication to the Badicheq and for additional equalizing charge current.

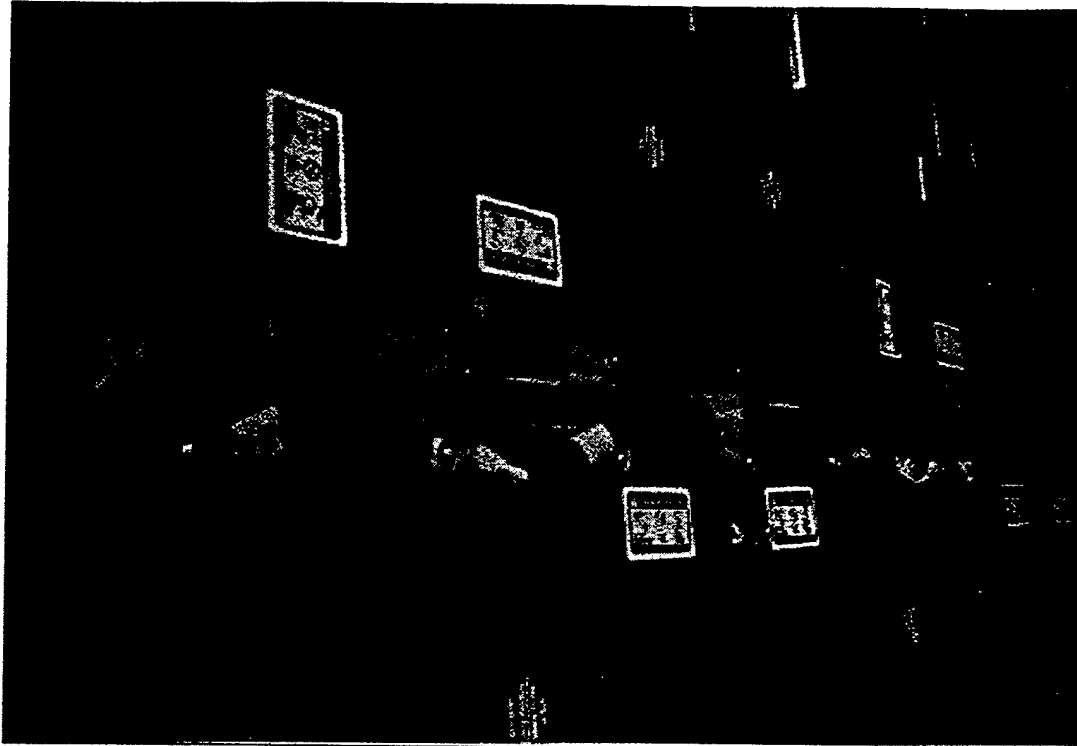

Figure 3. Badicheq communication wires connected to each positive terminal of a two-battery set.

The charger must be able to take the signal of the Badicheq system which signals the charger to reduce its current when the first module reaches the temperature compensated clamp voltage of 14.25 volts. The charger must be a programmable switchmode charger that will accept a pulse width modulated (PWM) signal. A C1/CV/C1 charge profile is recommended with the charge current to the batteries at 38 amps. With a parallel pack the charger needs to supply 76 amps. The combination charger described below provides about 34 amps to the batteries.

The bulk charge is provided by a combination of the original 10 kW Chloride charger and a 3 kW Mentzer charger installed inside the Chloride charger case. The overvoltage limit on the Chloride charger was adjusted so that it turns the charger off when the pack voltage has reached an average 14.25 volts per battery. The 3 kW Mentzer charger continues to operate to finish the charge under control of the Badicheq battery management system. This charger accepts the signal from the Badicheq is delivered through an additional Amp connector attached to the Chloride charger cord and plug assembly. This must be plugged in to completely charge the vehicle.

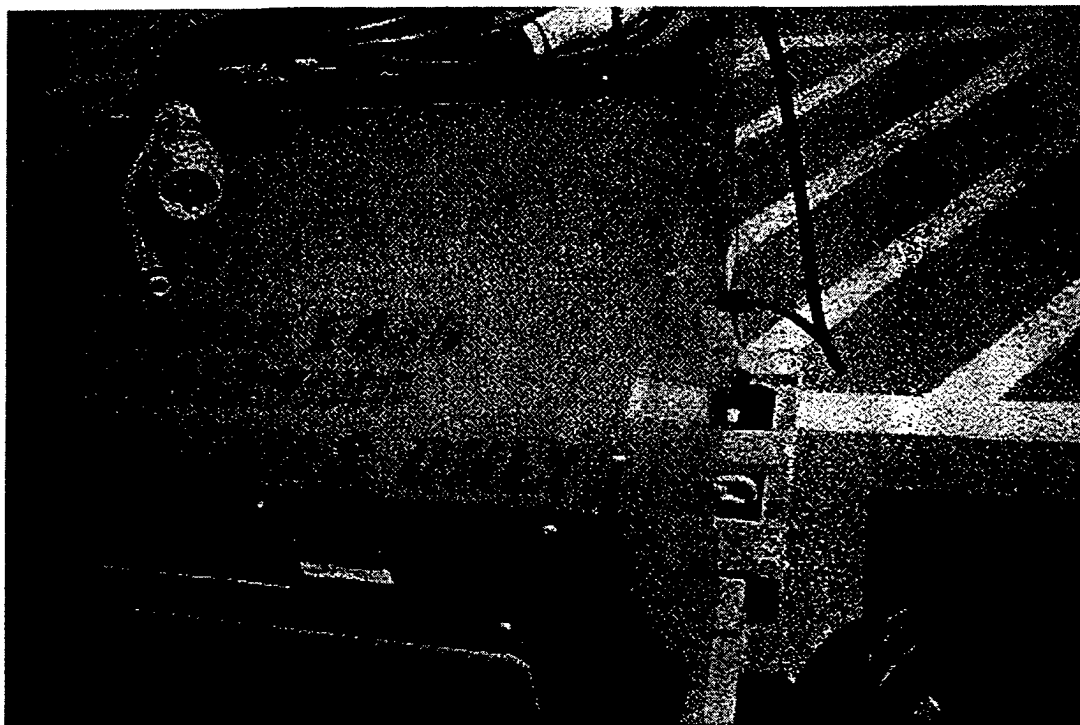

Figure 4. Original CEN charger with Mentzer charger installed inside. Yellow plug is an extra communication link with the Badicheq battery management system.

VI. State of Charge Indicator

The analog state of charge indicator supplied with the Badicheq system was mounted in the dash. This display gives the driver an indication of the capacity with the needle moving from 100% position down to zero with zero meaning 80% depth of discharge. There are also 3 LED lights to inform the driver if the battery pack is being charged (green LED) , is approaching 80% DOD or at 80% DOD (yellow LED) or if there are any error conditions (red LED).

VII. Performance Characteristics

Total weight of the vehicle with the new battery pack is 7500 pounds. This is about 400 pounds less than the weight of the original G-Van. Since the energy stored on board the vehicle is approximately the same, a slight increase in range was anticipated due to the 5% decrease in vehicle weight.

After testing the vehicle on short trips, the vehicle was charged and then driven over hilly terrain with stop and go traffic. A total of 50 miles was achieved when the battery pack was discharged to 80% depth of discharge. Acceleration

throughout the discharge cycle was significantly improved over the previous battery pack. Remarks from the Van Pool participants verify this improvement in acceleration.



Figure 5. SMUD G-Van with Horizon batteries installed is in daily use as an employee Van Pool.

VII. Data Acquisition Results

The Badicheq data is automatically collected in the Badicheq's memory and can be downloaded through an RS232 cable. The Badicheq collects statistical data for the life of the battery pack. Figure 6 shows the consistent pattern of use of the G-Van in Van Pool operations (consistent discharge cycles - as a percent of total charge - over a large number of operating cycles).

Figure 7 is a chart showing the charge cycle with the combination Chloride and Mentzer chargers. The Chloride charger reduces its current as the pack voltages rises until it hits about 2.4 volts per cell (14.4 volts per module). Then the Mentzer charger continues (the horizontal line from 25% to 37% until the Badicheq signals the charger to ramp down the current slowly and end with a low amperage finish charge. The batteries continue to float at around 2.4 volts per cell until charging is terminated.

APPENDIX F

**HORLACHER VEHICLE
BATTERY PACK DEFINITION**

Includes:

- E036 Horlacher Sport
- E037 Horlacher Pickup I
- E038 Horlacher Pickup II

Sacramento Municipal Utility District

July 1996

Horlacher Sport

I. Battery Pack Specification

The battery pack consists of 12 Horizon Model 12N95 (12 volt - 95 AH) advanced lead acid batteries assembled in a series string for a nominal pack voltage of 144 vdc. The weight of the battery pack is 720 pounds (327 kg). The pack is divided in two parts, 6 batteries in the nose of the vehicle and 6 behind the passenger compartment, forward of the rear axle. A diagram of the battery pack is shown in Figure 1.

II. Battery Box Design

The battery boxes are integral with the vehicle structure. Materials of construction are a composite consisting of carbon fiber over polyurethane cores. Diagrams of the front and rear battery boxes are provided in Figures 2 and 3, respectively.

The front battery box contains 2 layers of 3 batteries mounted laterally. It is not a box, per se, but consists of the batteries stacked in the front well and held down with straps (which don't always work). A front box cover, shown in Figure 2, is proposed for better holding the batteries and for mounting of the Badicheq and dc-dc converter. The front box is not actively ventilated (i.e. no fan), but holes in each fender well provide for ambient air flow axially along the battery length.

The rear battery box contains 3 layers of 2 batteries mounted laterally. The box is cooled by muffin fans pulling air from one side of the box to the other, axially along the battery length. Size and location of vent holes are shown in Figure 3.

III. Temperature Sensors

The vehicle is equipped with the Badicheq charge management system. This system monitors and records pack maximum and minimum temperature during an operating cycle (either charge or discharge). The Sport has two temperature sensors, one in each battery box (see Figure 1). The front sensor is located between batteries #8 and #11. The rear sensor is located on the outside of battery #4.

IV. Charging System

The battery pack is charged with a 3 kW Mentzer charger operating from a 220 vac, 20 amp (minimum) service. The Mentzer charger is controlled by the

Badicheq, which also provides the operator with discharge information during driving to prevent under-voltage on the weakest battery.

The battery current limits on the AMC 320 motor controller are set at 180 amps on discharge and 80 amps on charge (regen). Battery cables are 2/0 600V welding cable, rated at 275 amps.

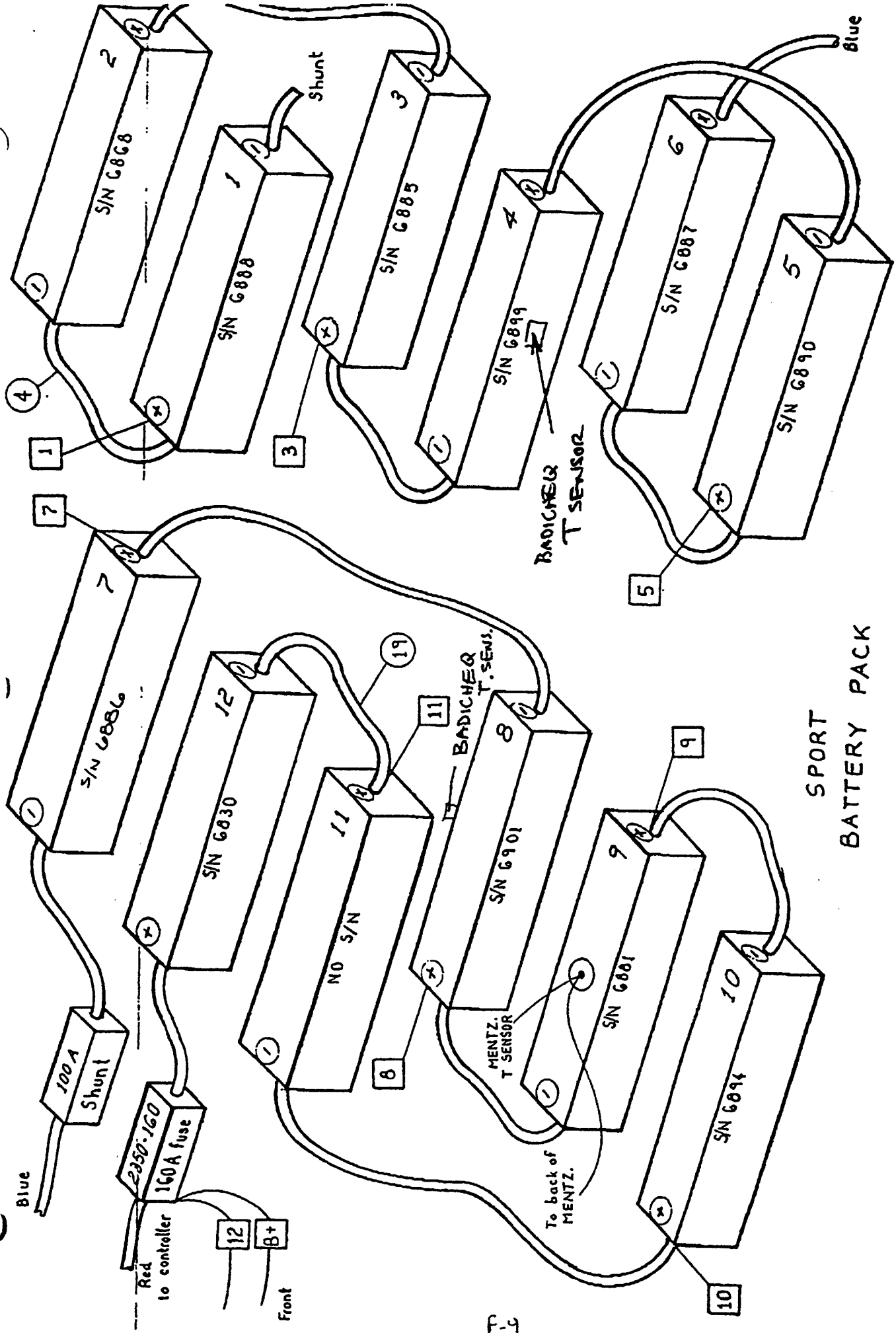

SPORT BATTERY PACK

Figure-1. Horlocker Sport Battery pack

SPORT FRONT BATTERY PACK

1/5 SCALE

PROPOSED COVER
MT6 FOR BADICHER &
DC-DC CONV.

12N95
HORIZON (G)

50MM HOLES
EACH FENDERWELL

HONEYCOMB

FOOT
WELL

IMPACT BEAM

F.V.
252

395

845mm wide b. box.

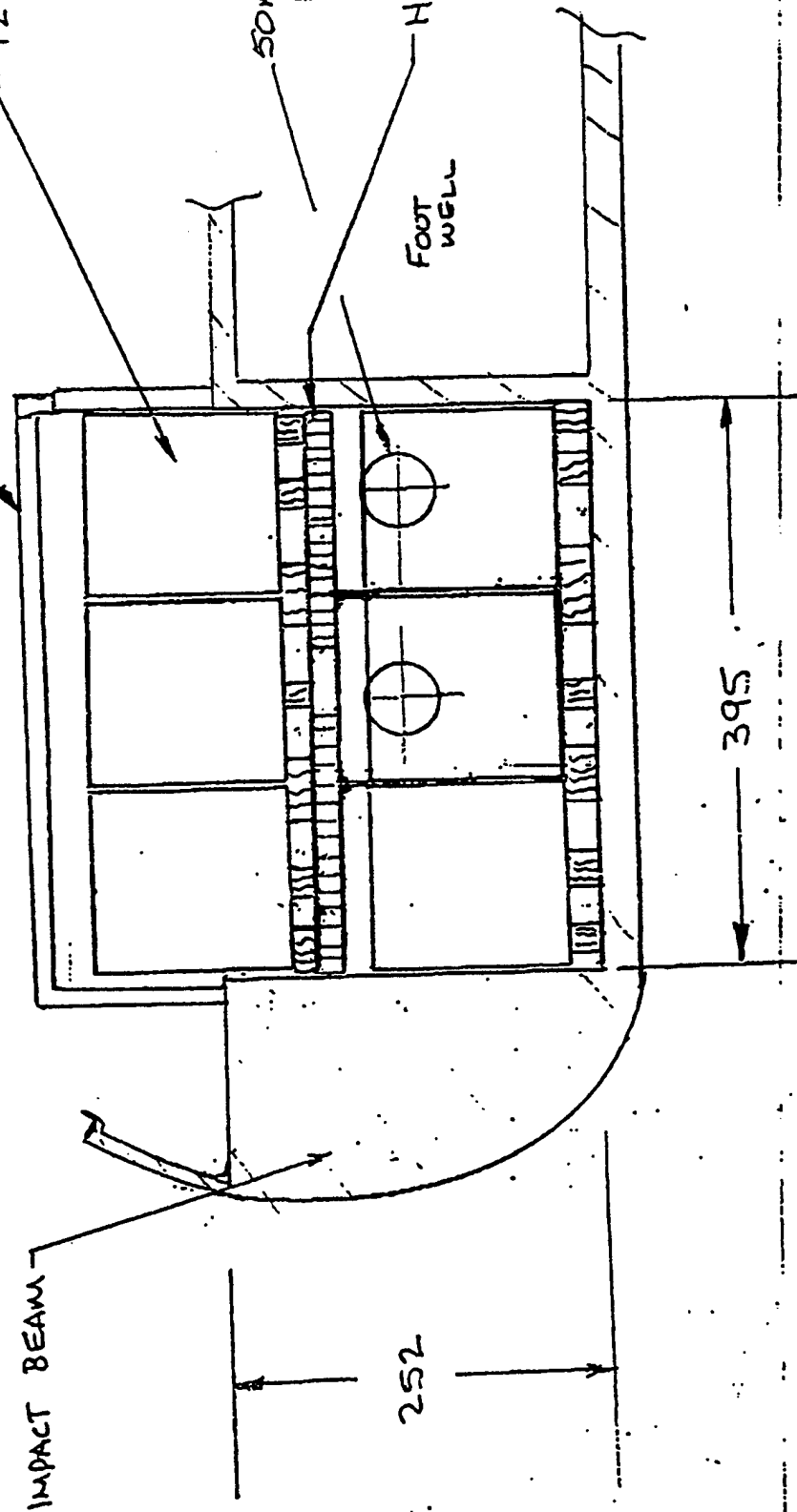

WUWAF 7/23/96

Figure 2. Horlacher Sport Front Battery Box

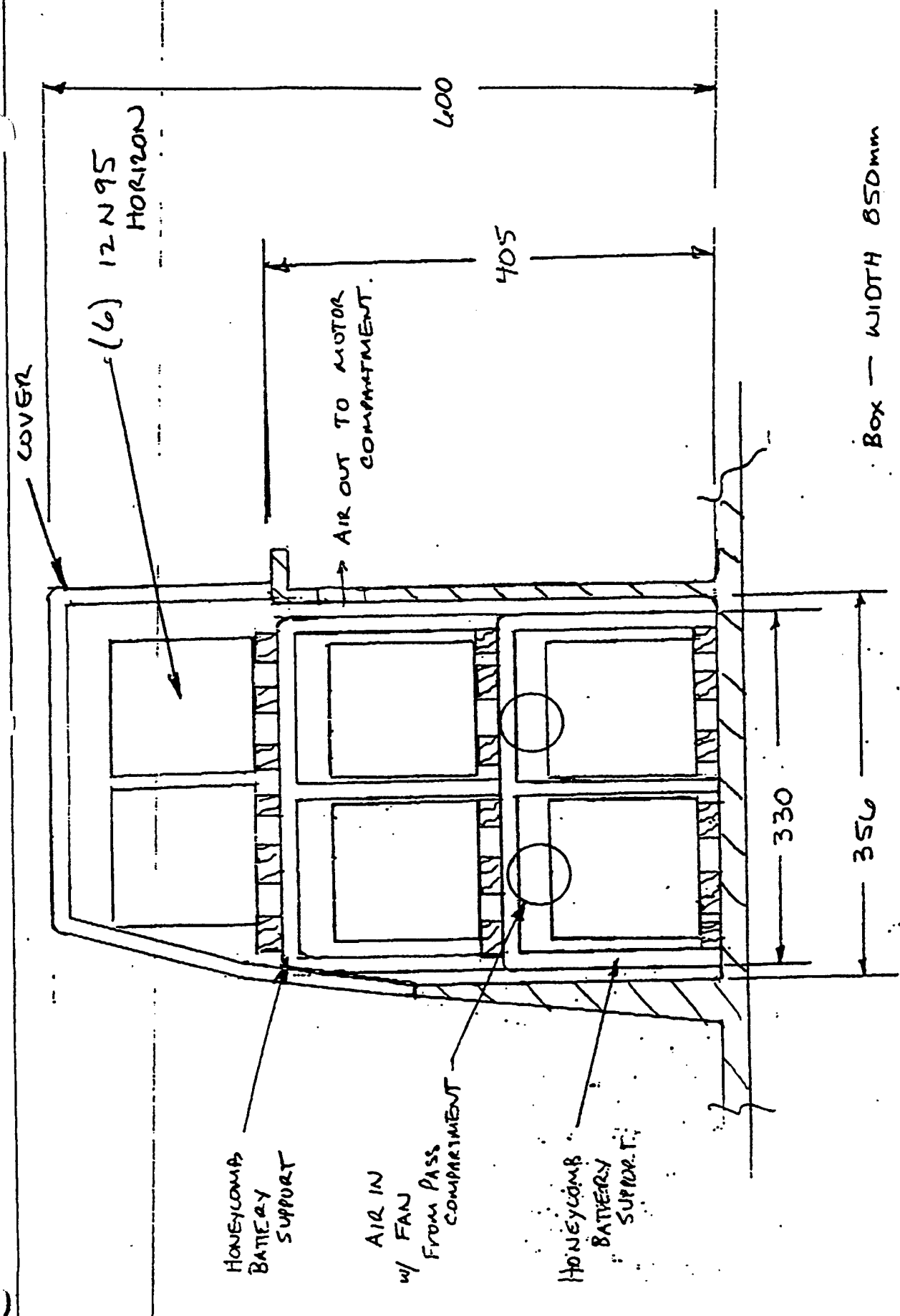

SPORT REAR BATTERY BOX 1/5 scale.

Figure 3. Horlacher Sport Rear Battery Box

WAPF 7/23/94

REVISED BY: [unclear] DATE: [unclear]

Horlacher Pickup I

I. Battery Pack Specification

The battery pack consists of 12 Horizon Model 12N95 (12 volt - 95 AH) advanced lead acid batteries assembled in a series string for a nominal pack voltage of 144 vdc. The pack is divided in two parts, 4 batteries in the nose of the truck and 8 underneath the passenger seat (extending rearward under the bed).

II. Battery Box Design

The battery boxes are integral with the vehicle structure. Materials of construction are a composite consisting of glass fiber over polyurethane cores. Diagrams of the front and rear battery boxes are provided in Figures 1 and 2, respectively.

The front battery box contains 2 layers of 2 batteries mounted laterally. The box walls are 3/4" foam core composite. Foam blocks are used to support the batteries within the box, with the spacing and dimensions shown in Figure 1. 2.25 inch diameter ventilation ducts are located in the lower front corners that vent forward in the vehicle. A fan on one side of the box pulls in air from the wheel well axially along the battery length.

The rear battery box contains 8 batteries in a single layer mounted axially. A wiring tunnel passes through the center of the box fore to aft. Foam blocks support the batteries within the box, and completely cover batteries #5 and #12. Two holes at the front of the box (near batteries #6 and #11) provide ventilation to the bottom of the vehicle (see Figure 2).

III. Temperature Sensors

The vehicle is equipped with the Badicheq charge management system. This system monitors and records pack maximum and minimum temperature during an operating cycle (either charge or discharge). A recent inspection identified a single temperature sensor, located in the rear box on the surface of battery #6. The Badicheq system is set up to record two temperature measurements, and it is likely that a sensor does or did reside in the front box.

IV. Charging System

The battery pack is charged with a 3 kW Mentzer charger operating from a 220 vac, 20 amp (minimum) service. The Mentzer charger is controlled by the Badicheq.

13 112 20 BUREAU FILES 4 SQUARE
 13 131 50 TUBES 1/2" DIA. 5 SQUARE
 13 132 50 TUBES 1/2" DIA. 5 SQUARE
 13 133 50 TUBES 1/2" DIA. 5 SQUARE
 13 134 50 TUBES 1/2" DIA. 5 SQUARE
 13 135 50 TUBES 1/2" DIA. 5 SQUARE
 13 136 20 RECYCLED WHITE 5 SQUARE
 MADE IN U.S.A.

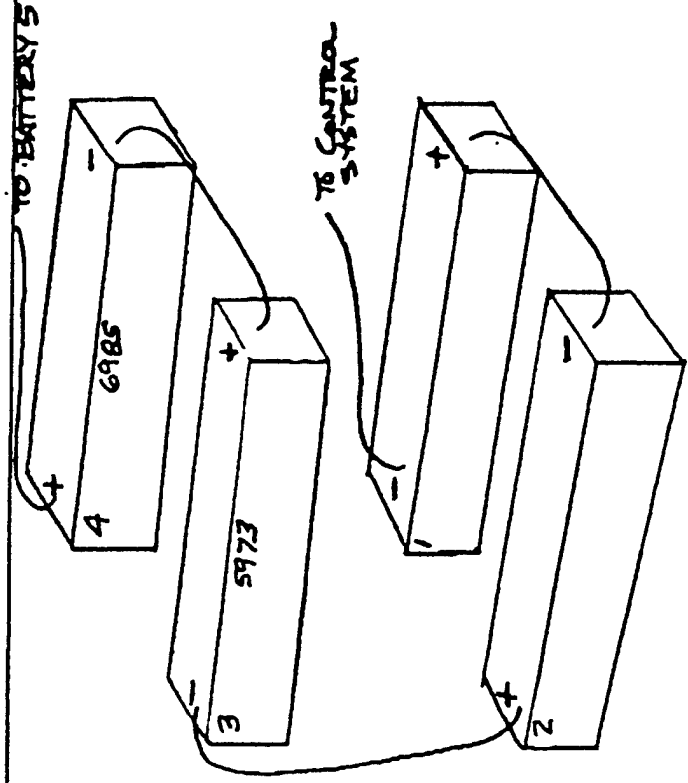

McLELLAN AFB
 GREEN HORLACHER
 PICKUP I

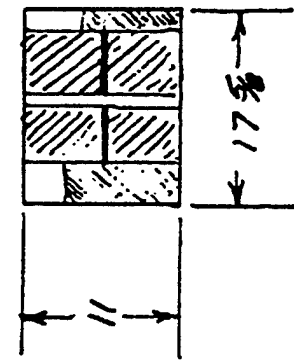
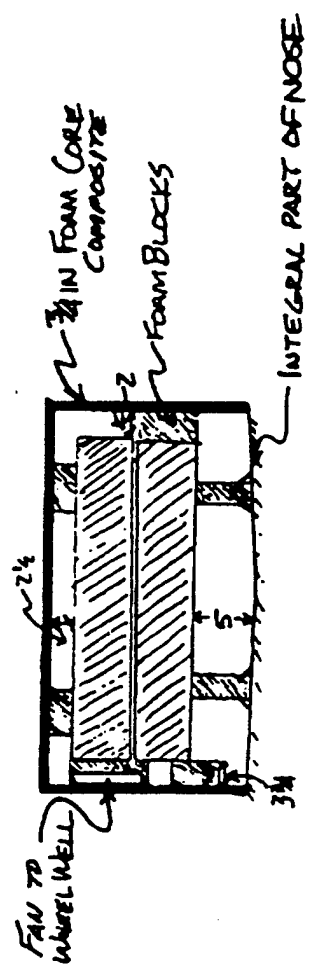

SIDE

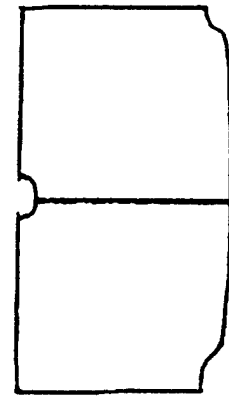

BACK

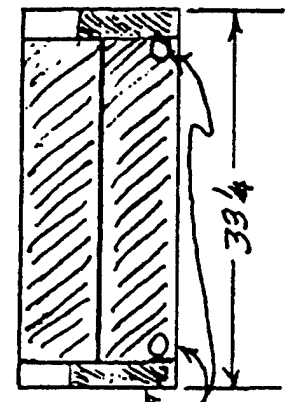

FRONT

NOTCH FOR WIRES

VENTILATION
 DUCTS TO FRONT
 OF VEHICLE
 (2 1/2 IN DIA)

2 REEL BOX COVER
 COVER SECURED BY SQUARE
 TUBING BAR BOLTED TO FENDER
 WELLS.

FRONT BATTERY BOX

FIGURE 1

NOT TO SCALE
 ALL DIMENSIONS IN INCHES

F-8

100% RECYCLED PAPER
 50% RECYCLED FIBER
 100% RECYCLED INK

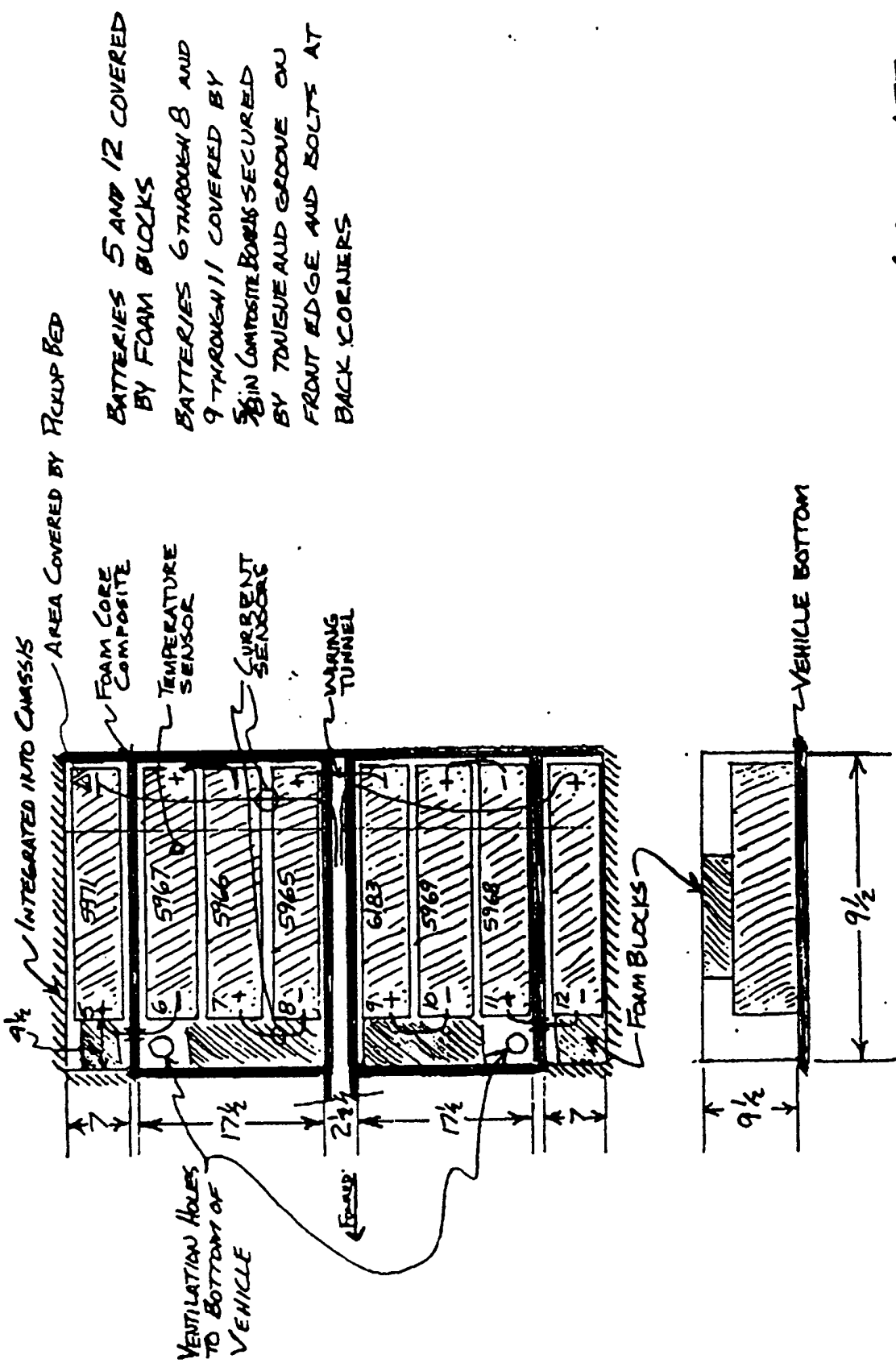

BATTERIES 5 AND 12 COVERED BY FOAM BLOCKS
 BATTERIES 6 THROUGH 8 AND 9 THROUGH 11 COVERED BY 5/8 IN COMPOSITE BORDERS SECURED BY TONGUE AND GROOVE ON FRONT EDGE AND BOLTS AT BACK CORNERS

MC CLELLAN AFB
 GREEN HORLACHER
 PICKUP I

BACK BATTERY BOX

Figure 2.

Horlacher Pickup II

I. Battery Pack Specification

The battery pack consists of 14 Horizon Model 12N95 (12 volt - 95 AH) advanced lead acid batteries assembled in a series string for a nominal pack voltage of 168 vdc. The weight of the battery pack is 847 pounds (385 kg). The pack is comprised of two layers of 7 each batteries, located under the driver and passenger seats and extending rearward under the pickup bed. A diagram of the battery pack is shown in Figure 1.

II. Battery Box Design

The battery box is integral with the vehicle structure. A diagram of the battery box location in the vehicle is shown in Figure 2. Materials of construction are a composite of epoxy/glass fiber over honeycomb cores. Overall dimensions are 1100 mm long x 1100 mm wide x 280 mm high. The batteries, mounted longitudinally, take up 770 mm of the box length, leaving "space" fore or aft. For better weight distribution and vehicle ride height the batteries are presently positioned in their forward position (8/27/96).

Two battery compartment inlet ventilation ducts originate at the front of the rear wheel wells. Four thermostatically controlled (muffin) fans draw air from the rear wheel wells and routes the air to the forward left and right sides of the battery box. The thermal switch for the fans is active at all times. The ducted air enters the sides of the battery box, passes over the battery pack and exits through holes in the rear of the battery compartment.

Each battery in the lower row sits on top of a 55 watt, 230 volt, model CH-8422, Prang and Partner AG silicone coated electric heater pad. These pads are wired in parallel and are bonded to a thin aluminum sheet to maintain location and even out the distribution of heat to the batteries in the box. The heater pads are thermostatically controlled by a temperature sensor located on the lower level between batteries 7 and 8. The heater pads can be set to maintain the battery pack temperature during cold weather for optimum range and battery performance. At this time the blanket is not connected but could be with notice. The battery blanket will be operating during the winter of 1996 / 1997.

III. Temperature Sensor(s)

The vehicle is equipped with the Badicheq battery management system. This system monitors and records pack maximum and minimum temperature during an operating cycle (either charge or discharge). Quantity and location of sensors are shown in Figure 3 (8/27/96). Due to relatively frequent relocation (move forward/aft) and changeout of pack batteries, it is likely that the sensors from the original installation of the pack have been moved.

IV. Charging System

The battery pack is presently charged with a 3.3 kW Mentzer charger operating from a 220 vac, 20 amp (minimum) service. The Mentzer charger is controlled by the Badicheq, which also provides the operator with discharge information during driving to prevent under-voltage on the weakest battery. Charge time will likely be approximately 4 to 6 hours from 80% DOD.

Our Brusa 6.6kW charger will be installed once the GFI tripping problem is fixed. This charger operates at 220 vac and is to be connected to GFI protected 50 amp service with a 14-50 plug. Charge time will likely be approximately 2 to 3 hours from 80% DOD.

The battery current limits on the AMC 325 controller are set at 275 amps on discharge and 100 amps on charge (regen). Battery cables are 2/0 600v welding cable rated at 275 amps, continuous duty.

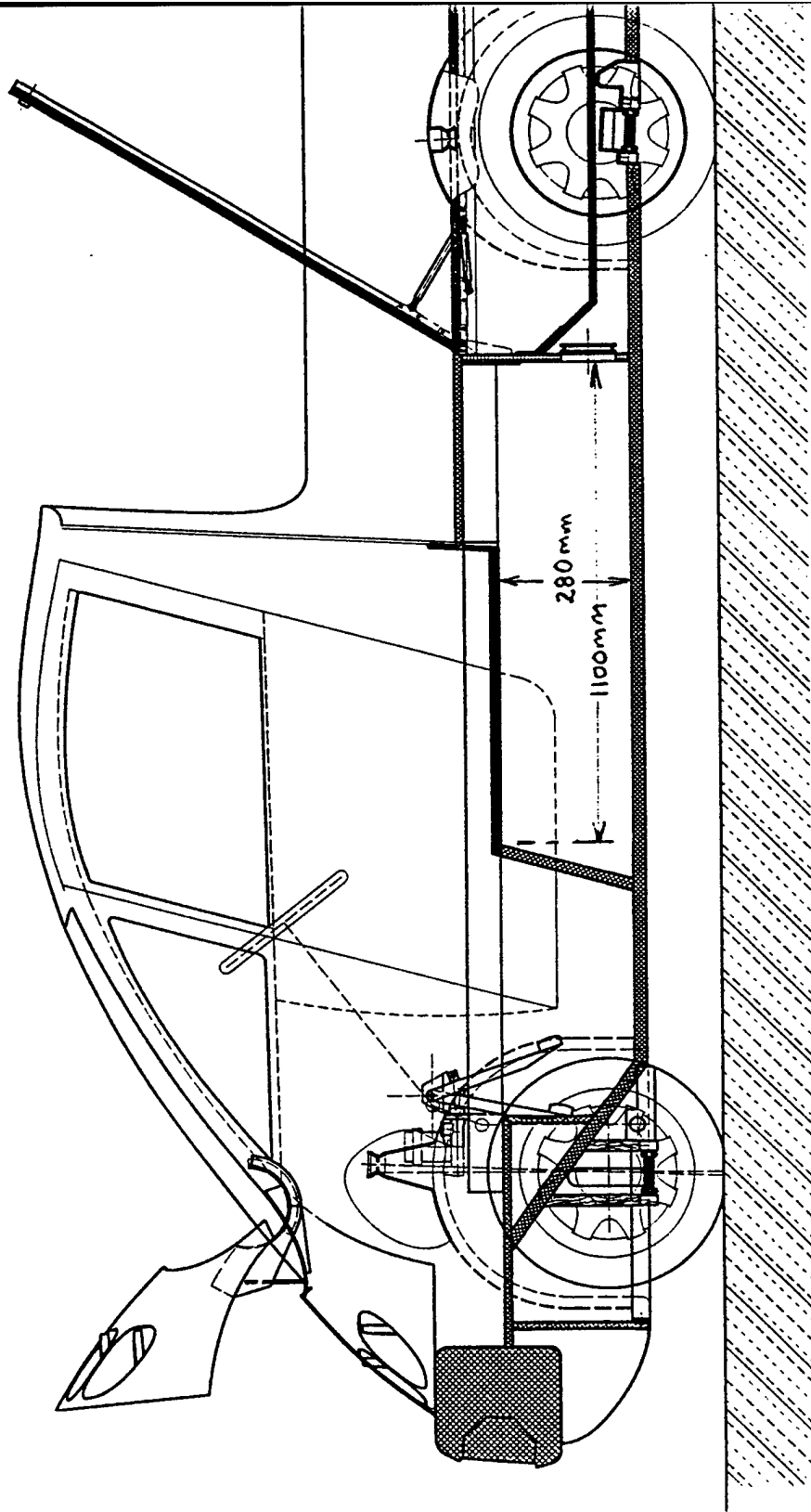

FIGURE 2

HORLACHER
P/U. II

BADICHEQ Cycle: 76
FRONT →

E-038

Date: 27 Aug. 96
Mileage: 592.5

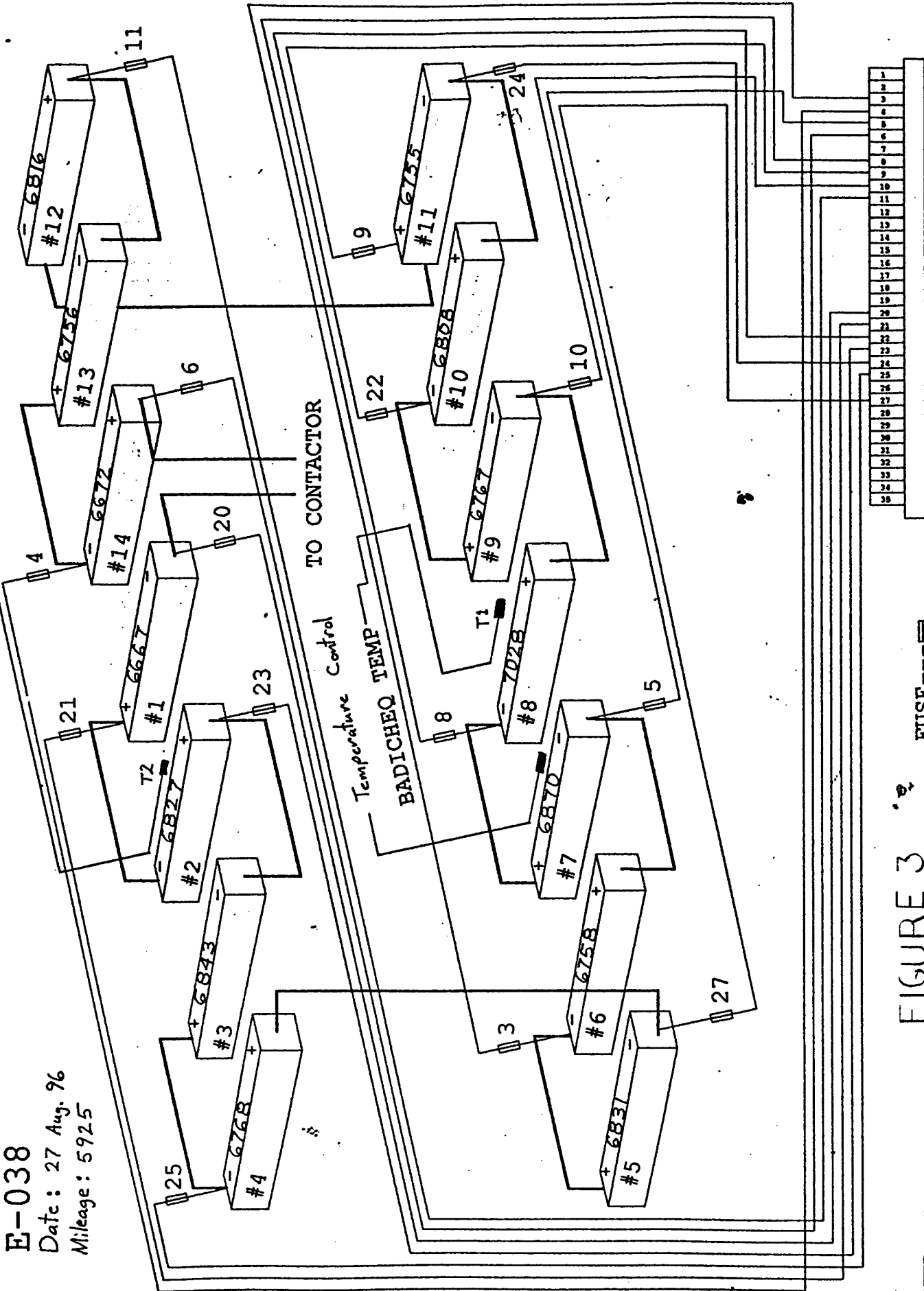

F-14

FIGURE 3

FUSE

APPENDIX G

**ADVANCED LEAD ACID BATTERY DEVELOPMENT PROJECT
VEHICLE RANGE TEST REPORT**

Advanced Lead Acid Battery Test Project Range Test Report

This report describes the conditions and results of the range testing performed on vehicles in the Advanced Lead Acid Battery Test Project.

A 45 mile per hour constant speed range test was chosen to allow comparison with vehicles undergoing a similar test for EV America. A track had to be located where a constant speed of 45 mph was possible. The California Highway Patrol Test Track in West Sacramento was found to be the best track available for this purpose. It is a 1.8 mile moderate speed closed track with one small banked curve and one small elevation change.

Test Methodology

The range test was begun by accelerating up to 45 mph on the test track and maintaining the 45 mph speed the entire test until the batteries were at 80% depth of discharge (DOD). Because the track was not perfectly flat and contained some curves, it was only possible to maintain a speed of 45 mph on approximately 75% of the track.

Two vehicles, the Solectria Force and the Horlacher Sport, were equipped with dash-mounted auxiliary potentiometers that can control the speed manually by limiting the current output of the controller. The driver was able to determine the minimum current requirement necessary to maintain the 45 mph speed and limit the current level to that minimum by manually setting this potentiometer. For the entire course, the accelerator pedal was fully depressed and the current limit was maintained. During the elevation change and the tight corner, the vehicle slowed down slightly from 45 mph and the vehicle subsequently gained speed on the decent, going slightly over 45 mph. The discharge current was constant, as if the track was perfectly flat. The accuracy of this method is illustrated by the attached graphs of the actual tests (Attachment A). These graphs are printed from records of the Badicheq battery diagnostic and charge equalization system. The vehicles equipped with an auxiliary potentiometer exhibited constant currents, shown as a straight horizontal line in the bottom half of the graph.

In the Horlacher Pickup II and SMUD G-Van, where there was no auxiliary potentiometer control in addition to the accelerator pedal, the driver had to hold the current constant using the accelerator pedal. As this was a difficult task, the current fluctuated as is evident by the jagged line on the attached discharge graph. Nevertheless, fairly consistent lap times were achieved indicating that the average 45 mph speed was maintained.

Since these were baseline range tests, it was our intention to begin each test with a fully charged and balanced battery pack, cycled to its full capacity. Unfortunately, the test was performed under less than ideal conditions for a baseline test. Two of the battery packs were very new and had not been cycled to full capacity. These two vehicles were also undergoing beta-testing of a new charging algorithm and it was determined before that test that the charging algorithm was

not fully charging the batteries. Therefore, these two packs started the test slightly undercharged between 12.1 and 12.4 average volts per module (temperature compensated volts).

Our decision to terminate the test at 80% DOD differs from the EV America test which runs the vehicle until it can no longer maintain 45 mph. Since the Horizon battery maintains a high specific power even at 80% DOD, and the "knee" of the curve drops off very quickly after 80% DOD, the vehicle would not show any indication of slowing down until the battery was almost 100% discharged. This is not desirable for any lead acid battery and would subject the batteries to greater hardship than recommended for a lifecycle test.

Test Conditions

Following is a summary table of the test conditions for the baseline range tests:

	Solectria Force	Horlacher Sport	Pickup II	G-Van
Date and Time	9/9/95 - 8:56AM	9/9/95 - 10:39AM	9/19/95 - 5:13PM	2/11/96 - 3:30PM
Battery Pack	144 volt Horizon	144 volt Horizon	168 volt Horizon	216 volt Horizon
Previous cycles on battery pack	7 cycles	12 cycles	3 cycles in vehicle 10 factory cycles	34 cycles
Ambient temperature	approx 62° F	approx 70° F	approx 68° F	approx 66° F
Vehicle curb weight	2265 pounds	1470 pounds	2125 pounds	7500 pounds
Weight of Driver	210 pounds	210 pounds	210 pounds	170 pounds
Tire inflation	to rated capacity	to rated capacity	to rated capacity	to rated capacity
Current to maintain 45 mph	50 amps	42 amps	50 amps	80 amps
DC wh/mile used	159 wh/mile	120 wh/mile	146 wh/mile	820 wh/mile
State of Charge at start of test	avg. 12.4 volts (slight undercharge)	avg. 12.1 volts (slight undercharge)	avg. 12.95 volts	avg. 14.2 volts
Voltage at 80% DOD	11.4 volts/module (1.9 volts/cell)	11.5 volts/module (1.933 volts/cell)	11.4 volts/module (1.9 volts/cell)	11.4 volts/module (1.9 volts/cell)
Auxiliary potentiometer	Yes	Yes	No	No

Each vehicle is equipped with a Badicheq system which monitors and records the voltage and current of each battery periodically during every charge and discharge. The driver can view the most recent battery data during the cycle by accessing it using a personal computer. The driver reported this data on the battery pack and readings from the odometer and ampmour counter mounted on the vehicle dash. This data was read at the track's start/finish line and was communicated by two-way radio to the data recorder. The range test data sheets are attached to this report (Attachment B).

Determining End of Test

Lead acid batteries have a very consistent relationship between current and voltage as to state of charge, known as the Puckert relationship. Discharge tests performed on the Horizon accurately predict what voltage will be reached when discharged at a particular current. For this range test, the Constant Current Discharge @ 80°F chart was used (see Attachment C) to predict the individual battery voltage when 80% DOD is reached.

For the Horlacher Sport which, required 42 amps to maintain 45 mph, we interpolated a 42 amp curve between the 32 amp and 50 amp curves. By extending the curve to the X axis, we see that we could maintain that discharge rate for approximately 2.3 hours if we were to discharge the battery 100%. Since we were only intending to discharge to 80%, we calculated the test would last 80% of 2.3 hours or 1.84 hours. The voltage line which intersects with the vertical line at 1.84 hours is approximately **11.5 volts, the voltage per battery when 80% DOD is reached at 42 amps constant discharge current.** This is equivalent to 1.933 volts per cell. In the Horlacher Sport, that voltage was reached at 94 miles.

For the Pickup II and the Solectria, which both required about 50 amps to maintain 45 mph, the curve is already plotted. The calculated 80% DOD (80% of 2.95 hours) is at 2.36 hours which intersects with **11.4 volts per module or 1.9 volts per cell.**

In every case, the *average* battery voltage was still above the cutoff voltage, but the tests were terminated because one or two of the weaker modules dipped below 80% DOD. In the Horlacher Pickup II, battery #7 quickly dropped in voltage at 88 miles, even though the average battery voltage was 1.96 volts per cell or 11.76 volts per module, essentially at 70% DOD.

The range tests were all terminated before the average pack voltage reached 80% DOD because one or two modules were discharged more deeply than the rest of the pack. Horlacher Pickup II pack had been precycled at the factory but a weak module caused early termination. This module is undergoing complete testing at Electrosorce at the time of this writing. The other battery packs were unbalanced because of the lack of a good finish charge caused by a charging algorithm beta-test problem mentioned earlier.

Range Test Results and Predicted Range

The Badicheq calculates the capacity which is discharged from the pack and compares that to the usable capacity to 80% DOD (based on the manufacturer's specified capacity of 95 Ahr at C/3 at 77° F). This number, under the column labeled QM, is updated every time the Badicheq takes a voltage measurement. A QM of 80 would indicate that you have discharged the battery pack to 80% DOD. The "QM" can be used to predict the range that would have been achieved had one module not dropped out early.

The table below shows the QM number at the end of each range test and the predicted range of each vehicle using the following formula:

$$\frac{\text{Miles achieved}}{\text{QM at test}} \times \text{times} = 80$$

For example - Solectria test:

$$\frac{64 \text{ miles}}{73 \text{ QM}} = 0.877 \times 80 = 70 \text{ miles predicted}$$

This calculation has been performed using results from the constant speed range tests and is shown in the table below:

	Solectria Force	Horlacher Sport	Pickup II	G-Van
Ending QM (DOD)	73	66	70	**
Miles Achieved	64	94	88	40
Optimal QM (80% DOD)	80	80	80	80
Miles predicted with full charge & balanced pack	70	114	101	54

** Capacity not calibrated for G-Van battery pack

Conclusions

The batteries performed well in these initial on-road range tests. The goals of the test were achieved, which were to perform a baseline test on the vehicles tested and to establish a test procedure for range testing where most conditions could be duplicated for future testing.

A second observation was the importance of accurately measuring the temperature of the batteries. If an inaccurate temperature measurement is used by the battery management system to calculate compensated module voltage, this can lead to reduced range (if actual voltage is underestimated) or module overdischarge (if actual voltage is overestimated).

To remedy this situation, attention needs to be paid to the method in which thermocouples are installed in the battery boxes, and the location. Normally the thermocouples are taped onto a centrally located battery in each box. This method is susceptible to the effects of temperature fluctuations caused by air flow within the battery box. Two methods to correct the problem are suggested: using cork mastic material to glue the thermocouple on; or by placing Styrofoam over the thermocouple to insulate it from moving air. The ultimate method would be to imbed thermocouples into the batteries during manufacture, however this is impractical at this time.

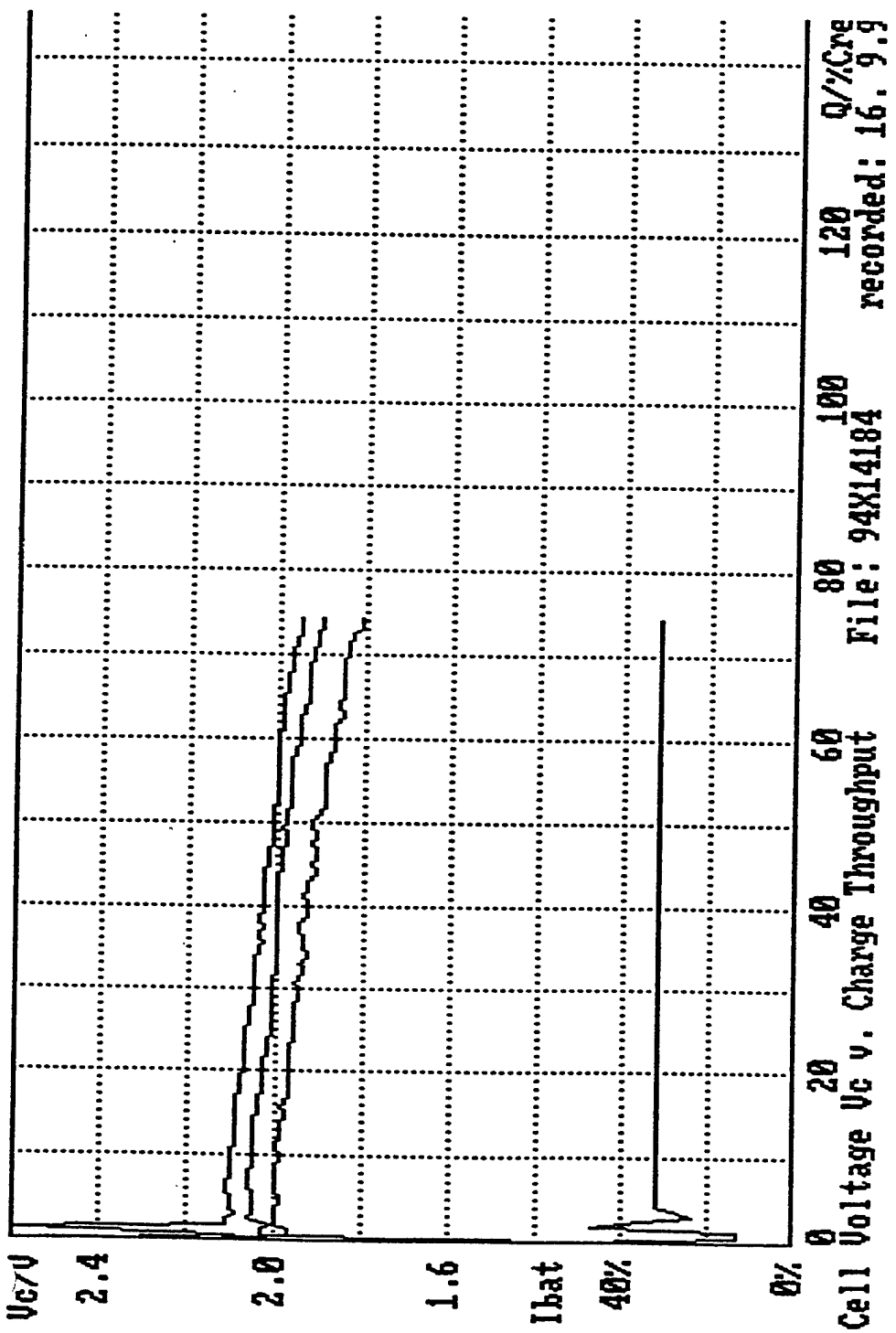

144 volt Horizon batteries - 45 mph constant speed range test in Solectria Force

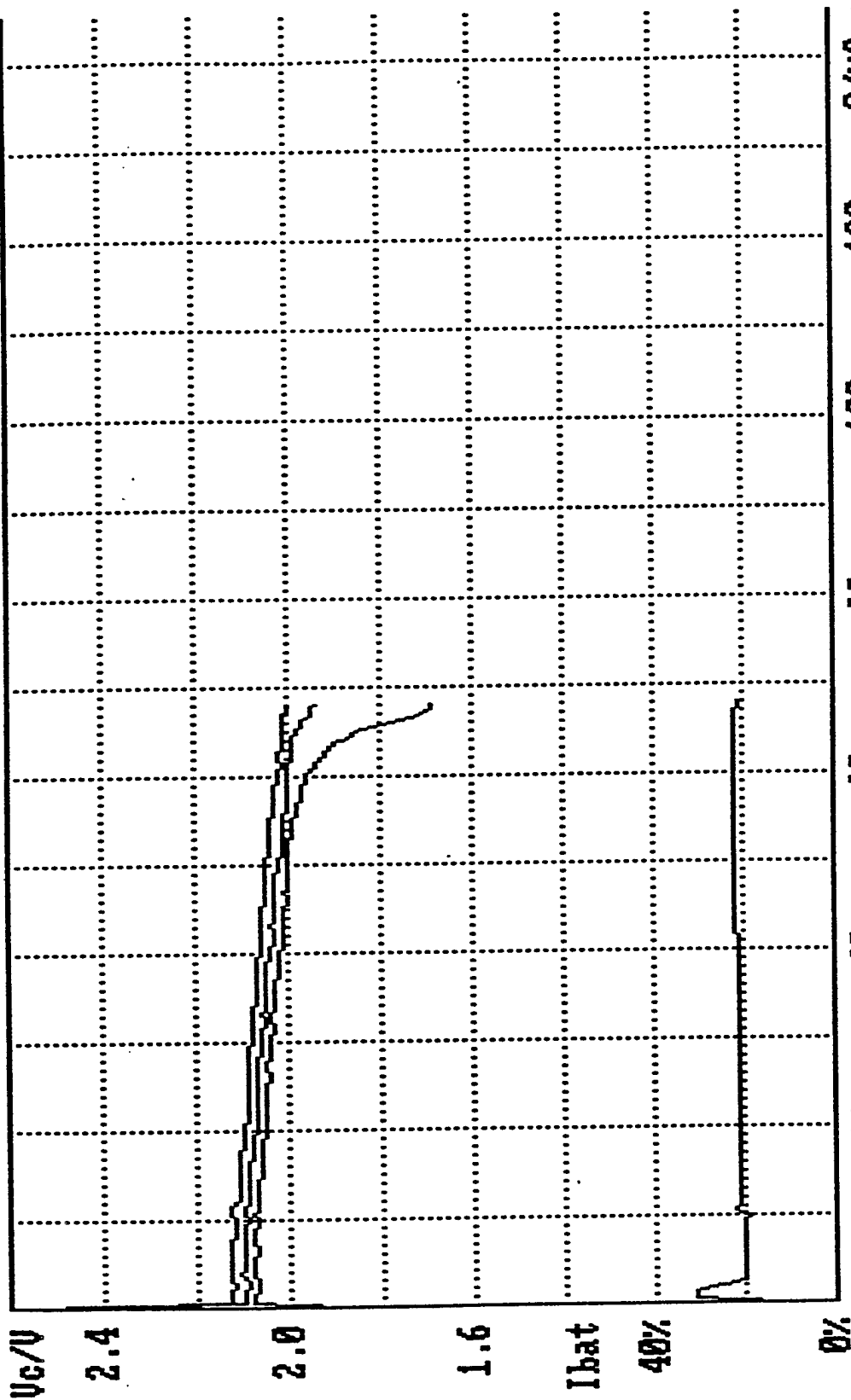

Cell Voltage Vc v. Charge Throughput File: 03636369 recorded: 16. 9. 9

144 volt Horizon batteries - 45 mph constant speed range test in Horlacher Sport

Attachment A

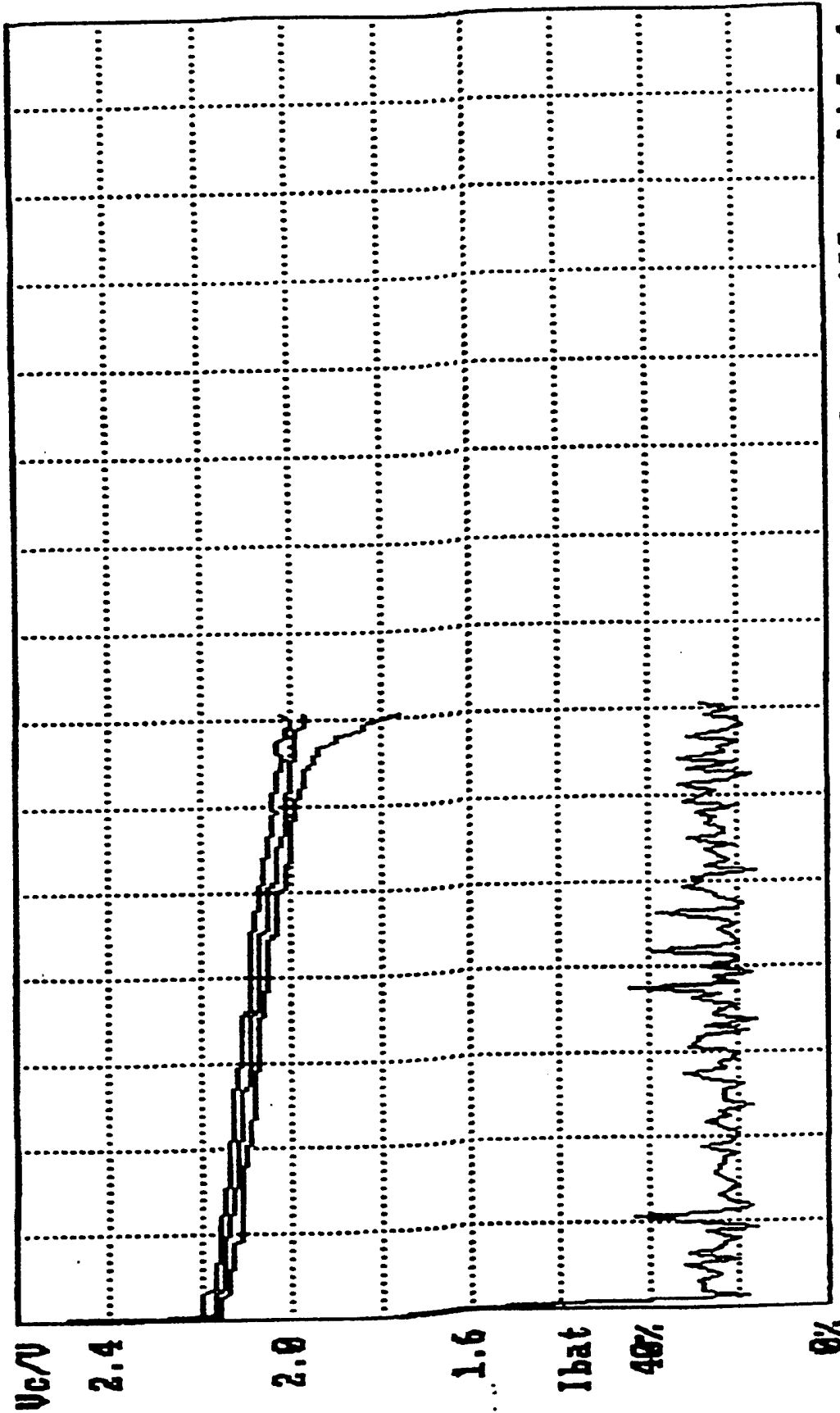

Cell Voltage Vc v. Charge Throughput File: 0381468 recorded: 19. 9.95
0 20 40 60 80 100 120 Q/%Cref

168 volt Horizon batteries - 45 mph constant speed range test in Horlacher Pickup II

Attachment A

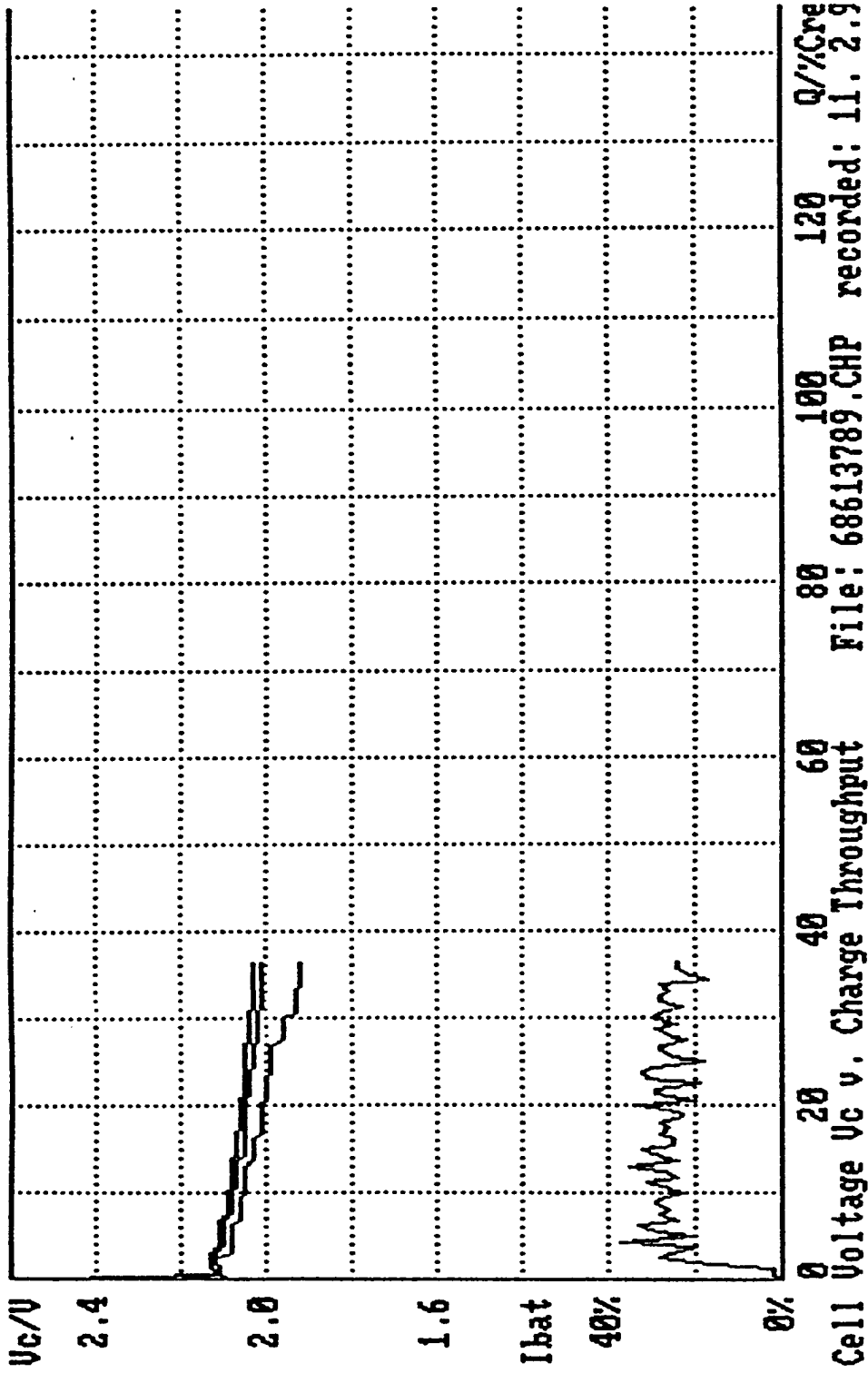

216 volt Horizon batteries - 45 mph constant speed range test in SMUD G-Van E686

Attachment B

McClellan Solectria Force Constant Speed Range Test @45 mph - CHP Track 9/16/95

Time	Odometer Reading	Amphours	QM (DOD)	Average Battery Volts*	Lowest 3 Batteries			Battery Module#s
					Bat 1	Bat 2	Bat 3	
8:56:27	4120.6	0.23			1980	2021		
8:57:27	4122.5	3						
	4124.3							
8:57:52	4125.1	5.95						
	4127.8	9.26			1992	2011	2024	
9:03:40	4129.6	11.39		2050				
9:06:10	1434.4	13.49						
9:08:30	4133.1	15.6		2044	1983	2002	2014	
9:10:55	4134.9	17.77						
9:13:20	4136.7	19.8		2034	1979	2001	2005	
9:15:50	4138.5	21.92						
9:18:10	4140.3	24.03		2021	1953	1988	2001	12,6,9
9:20:30	4142	26.14						
9:22:56	1443.8	28.24		2014	1953	1972	1979	12,6,9
9:25:20	4145.6	30.36						
9:27:45	4147.4	32.48						
9:30:10	4149.5	34.6		1998	1923	1956	1972	12,9,6
9:32:35	4150.9	36.72						
9:35:03	4152.7	38.84	37	1995	1933	1953	1962	12,9,6
9:37:28	4154.5	40.97						
9:39:55	4156.3	43.1	41	1988	1920	1953	1953	12,9,6
9:42:18	4158	45.24						
9:44:40	4159.8	47.37	46	1979	1904	1940	1946	12,9,6
9:47:08	4161.6	49.5						
9:49:35	4163.4	51.63	50	1969	1910	1930	1936	12,9,6
9:52:00	4165.15	53.76						
9:54:27	4166.9	55.9	54	1956		1920	1927	12,9,6
9:56:50	4168.7	58.04	56	1956	1878	1930		
9:59:20	4170.5	60.19	58	1949	1874	1914	1923	12,9,6
10:01:45	4172.3	62.35	60	1940	1865	1904	1910	12,9,6
10:04:10	4174	64.49	62	1933	1848	1894	1807	12,9,6
10:16:40	4175.8	66.65	65	1923	1845	1888	1824	12,9,6
10:00:03	4177.6	68.88	66	1920	1842	1884	1891	12,9,6
10:11:30	4179.4	70.94	68	1914	1842	1881	1891	12,6,5
10:14:00	4181.1	73.09	70	1907	1826	1881	1884	12,5,6
10:16:25	4182.9	75.25	72	1894	1819	1865		
10:18:00	4184.7	77.1	73	1891	1803	1845	1868	12,5,6
Current to maintain 45 mph = 50 amps								
* The voltage is read in volts per cell x 10 ⁻³								
Start	-4120.6 miles							
Finish	4184.7 miles							
	64.1 miles							

Attachment B

Horlacher Sport Constant Speed Range Test @45 mph - CHP Track 9/16/95

Time	Odometer		Pack Volts/ QM (DOD)	Average Battery Volts*	Lowest 3 Batteries			Battery Module#s
	Reading	Amphours			Bat 1	Bat 2	Bat 3	
10:39:20	36217.9	0.28						
10:42:00	6221	2.21		2016	2086	2086	2098	8,2,1
??	6224.1	3.71						
10:46:??	6227.2	5.17						
10:49:40	6230.3	6.63	QM=6	2106	2083	2086	2088	9,8,2
10:52:10	6233.4	8.09						
10:54:50	6236.5	9.55						
10:57:20	6239.5	11.04						
10:59:45	6242.4	12.55	150 volts					
11:02:18	6245.7	14.02						
11:04:48	6248.8	15.49		2089	2063	2076	2076	8,9,2
11:07:00	6251.9	16.96						
11:10:??	6255	18.4						
11:12:18	6258.1	19.88						
11:14:40	6261.1	21.35						
11:17:20	6264	22.82		2080	2054	2063	2070	9,8,12
11:19:??	6266.9	23.27	147 volts					
11:22:18	6270.4	25.74						
11:24:40	6273.5	27.2						
11:27:10	6276.6	28.67	QM=26	2070	2054	2054	2060	9,2,12
11:29:40	6279.7	30.13						
11:32:10	6282.8	31.59						
11:34:40	6285.8	33.06						
11:37:10	6288.9	34.52	QM=33	2060	2044	2044	2047	1,4,5
11:39:40	6292	36						
11:42:05	6295	37.46						
11:44:30	6298.2	38.93						
11:47:00	6301.3	40.41	QM=36	2050	2034	2034	2037	9,2,8
11:49:30	6304.4	41.88						
11:52:00	6307.4	43.37						
11:54:30	6310.6	44.85						
11:56:54	6313.6	46.31						
11:59:20	6316.7	47.8						
12:01:50	6319.8	49.29						
12:04:00	6322.9	50.77	QM=47	2031	2008	2018	2018	2,12,11
12:06:45	6326	52.35						
12:09:10	6329.1	53.74						
12:11:40	6332.1	55.21						
12:14:08	6335.2	56.7						
12:16:30	6338.3	58.17	QM=54	2014	1979	1995	1995	2,12,4
12:19:00	6341.4	59.65						
12:21:25	6344.5	61.13						
12:23:50	6347.6	62.61						
12:26:00	6350.7	64.08						
12:28:50	6353.8	65.57	QM=61	1985	1933	1953		11,12
12:31:20	6356.8	67.08						
12:33:40	6359.9	68.55						
12:36:10	6363.1	70.04	QM=64	1972	1868	1923	1936	2,11,12
12:37:40	6366.1	71.53	QM=66	1936	1712			2,11,12
End	6369.2	72.88						
Current to maintain 45 mph = 42 amps								
* The voltage is read in volts per cell x 10 ⁻³								
Start	-36217.9 km							
Finish	36369.2 km							
151.3 km =				94 miles				

Attachment B

Horlacher Pickup II Constant Speed Range Test @45 mph - CHP Track 9/19/95

Lap #	Stopwatch Time	Odometer		QM (DOD)	Average Battery Volts*	Lowest 3 Batteries			Battery Module#s
		Reading*	Amphours			Bat 1	Bat 2	Bat 3	
1	N/A	1334	2.24			1980	2021		
2	2:18:00	1343	3.8		2158	2141	2145	2154	7,11,13
3	2:20	1345	5.34						
4	2:23:00	1348	6.86						
5	2:22	1351	8.37						
6	2:24:00	2.9	9.85	6	2154	2132	2141	2141	11,7,6
7	2:23:00	5.6	11.29						
8	2:23:00	8.2	12.76						
9	2:23:00	10.9	14.21	11	2135	2115	2125	2125	11,7,6
10	2:24:00	13.6	15.66						
11	2:24:07	16.3	17.14						
12	2:23:04	18.9	18.61						
13	2:24:05	21.6	20.06	17	2122	2106	2106	210?	11,2,7
14	2:24:09	24.3	21.53						
15	2:23:00	26.9	23.02						
16	2:23:36	29.6	24.49						
17	2:23:18	32.3	25.97	23	2109	2086	2096	209?	3,2,7
18	2:24:09	34.9	27.44						
19	2:23	37.6	28.92						
20	2:23:36	40.3	30.42						
21	2:23:49	43	31.91						
22	2:23:41	35.6	33.41	29	2093	2076	2080	208?	11,7,3
23	2:23:02	48.3	34.9						
24	2:24:58	50.9	36.37						
25	2:22:35	53.6	37.89						
26	2:25:51	56.3	39.36						
27	2:23:50	58.9	40.87						
28	2:23:59	61.6	42.39						
29	2:23:49	64.3	43.9						
30	2:22:42	66.9	45.44	41	2070	2054	2060	2063	7,11,6
31	2:23:59	69.6	46.96						
32	2:25:04	72.3	48.46						
33	N/A	75	49.98						
34	2:23:00	77.6	51.53	47	2054	2034	2037	2041	2,7,11
35	2:22:00	80.3	53.11						
36	2:23:27	83	54.66						
37	2:23:03	85.6	56.22						
38	2:22:32	88.3	57.79	53	2031	2008	2008	2018	11,7,3
39	2:23:37	91	59.36						
40	2:24:57	93.6	60.91						
41	2:24:59	96.3	62.43	58	2011	1982	1988	1992	7,3,11
42	2:24:59	98.9	64.02						
43	2:22:10	101.6	65.63	61	2005	1972	1975	1988	7,3,11
44	2:23:31	104.3	67.2						
45	2:25:59	106.9	68.73	65	1985	1943	1972	1972	7,11,2
46	2:25:01	109.6	70.32		1985	1930	1962	1962	7,11,3
47	2:23:11	111.2	71.96	66	1975	1894	1959	1959	
48	2:23:53	114.8	73.58			1793			
49		117.7	75.03	70	1959	1748	1946	1953	7,11,3
Current to maintain 45 mph = 50 amps									
* The odometer was not calibrated properly and did not read in 10ths so the trip odometer which reads in 10ths was used after lap 6.									
** The voltage is read in volts per cell x 10 ⁻³									
Laps = 49 laps X 1.8 miles = 88.2 miles									

Attachment B

SMUD G-Van #686 Constant Speed Range Test @45 mph - CHP Track 2/11/96

Lap #	Stopwatch Time	Odometer Reading	State of Charge*	I _{me} (%) QM (DOD)	Average Battery Volts**	Lowest 3 Batteries			Battery Module#s
						Bat 1	Bat 2	Bat 3	
1		0	71						
2		1.7	70						
3		3.4	68						
4		5.1							
5		6.9							
6		8.65	63						
7		10.4	61		2070	2057			
8		12.1	60		2070	2057	2057	2063	16,2,17
9		13.9	58		2057	2037	2044	2044	16,17,2
10		15.6	55		2057	2037	2044	2044	16,17,2
11		17.35	53		2050	2018	2034	2034	17,16,2
12		19.1	51		2050	2018	2034	2034	17,16,2
13		20.8	50	I _{me} =21					
14		22.6	47		2044	1995	2021	2024	
15		24.35	45	QM=23					
16		26.1	43	I _{me} =25	2034	1979	2011	2021	17,2,16
17		27.85	41	I _{me} =25	2027	1953	2005	2005	17,16,2
18		29.6	40	QM=26	2027	1953	2005	2005	17,16,2
19		31.3	37			1927	1985	1995	17,2,16
20		34.8	36		2011	1910	1982	1985	17,2,16
21		36.6	36						
22		38.35	33		2011	1900	1982	1985	17,16,2
23		40.1	33						
Current to maintain 45 mph = 80 amps									
I _{me} = current as % of 320 (reference number), I _{me} of 25 = 25% of 320 = 80 amps									
* The digital Badicheq gauge was used but was not calibrated before the test.									
** The voltage is read in volts per cell x 10 ⁻³									
***The odometer reading is slightly out of calibration.									
Comparison of energy stored in G-Van with Horizon batteries									
Battery	# of cells	volts each	Ah at C/3	total pack kWh	@80% do	pack wt.			
Chloride 3 ET 215	36	6 V	191	41.4	33 kwh	2520 lbs.			
Horizon 12N95	36	12 V	95	41	32.8 kwh	2178 lbs.			

ELECTROSTAR RCE 12N95 MODULE
CONSTANT CURRENT DISCHARGE @ 80°F

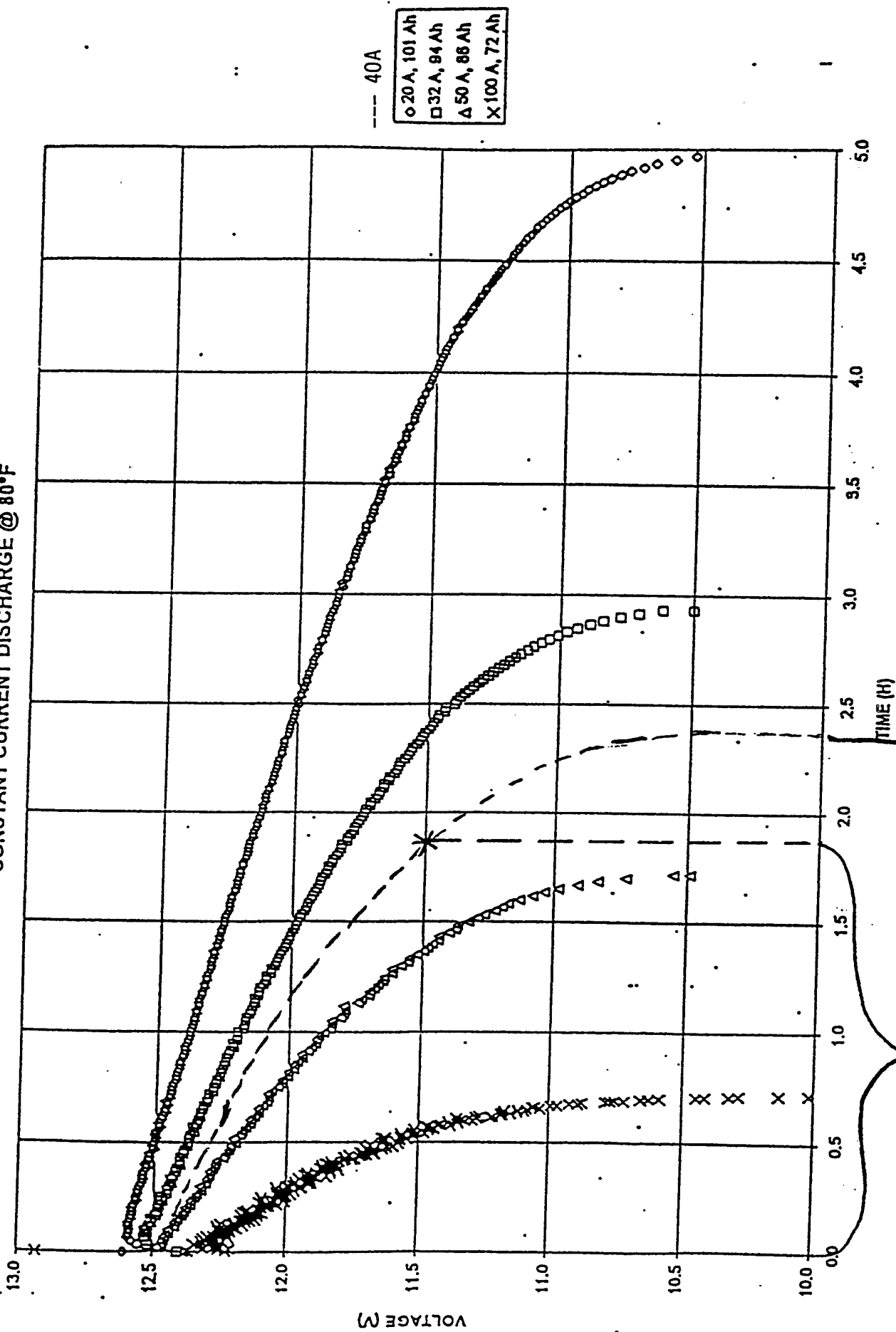

H. Talaria
4/18/95

APPENDIX H

**ELECTRIC VEHICLE CHARGER
POWER QUALITY TESTS**

Summary Report on Electric Vehicle Charger Power Quality Tests

Three chargers were tested by SMUD Power Quality Department in November, 1994. The vehicles were discharged to 80% DOD and then the charge cycle was recorded. The recording instrument was a Basic Measuring Instrument (BMI) 3030 made by Fluke Instruments.

Charging voltage in each case was 208 volts single phase. The following results are summarized:

	E005 3 kW Mentzer charger without PF correction	E037 3 kW Mentzer charger <i>with</i> PF correction	Impact #48 6.6 kW Hughes inductive charger
Instantaneous Power (Max)	2.5 kW	2.4 kW	6.4 kW
Power Factor (Ave)	0.55	0.87	0.86
Current Imbalance (Max)	17.3 amp	17.3 amp	30.5 amp

note: Power factor values were measured during the bulk charge phase after charger stabilization.

POWER QUALITY TEST
3 KILOWATT MENTZER CHARGER

EO05 PWR Q TEST Nov 15 1994 (Tue)

INSTANTANEOUS POWER 12:00:01 AM

FROM: MIDNIGHT Nov 13 1994 (Sun)

To: MIDNIGHT Nov 14 1994 (Mon)

Total:

MAX: 2.5 kW, 5:17 PM

MIN: 0.0 kW, 2:16 PM

Phase A-N:

MAX: 1.3 kW, 5:17 PM

MIN: 0.0 kW, 2:16 PM

Phase B-N:

MAX: 1.2 kW, 5:17 PM

MIN: 0.0 kW, 2:16 PM

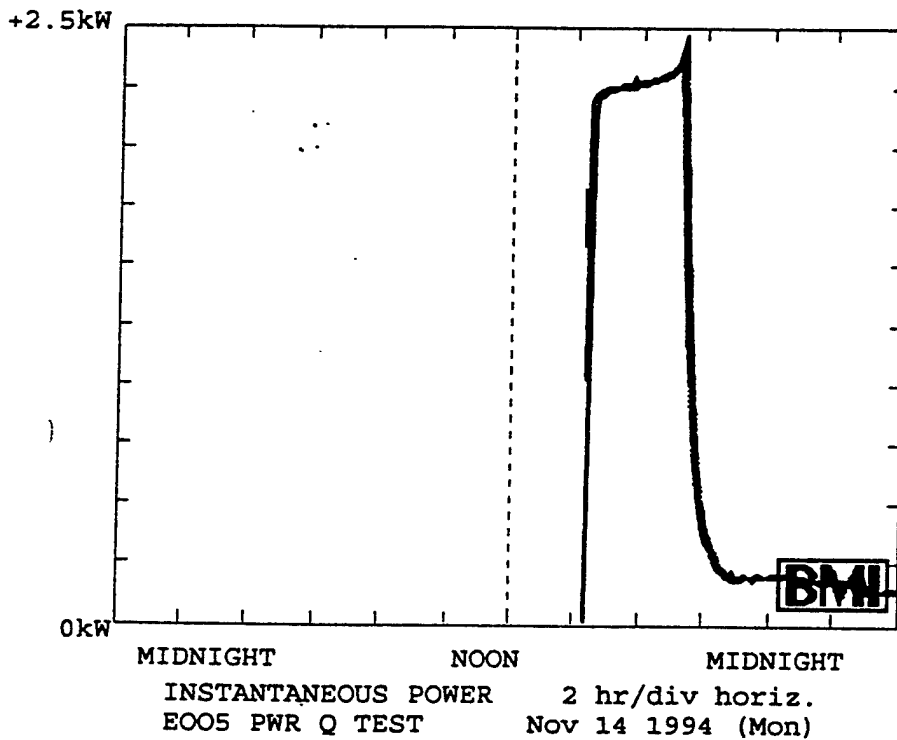

3kw mentzer
Location: Heavily to basement
208V single phase

EO05 PWR Q TEST Nov 15 1994 (Tue)

TRUE POWER FACTOR 12:00:59 AM

FROM: MIDNIGHT Nov 13 1994 (Sun)

To: MIDNIGHT Nov 14 1994 (Mon)

Total:

MAX: 1.00 PF, 2:16 PM
MIN: 0.13 PF, 2:16 PM

Phase A-N:

MAX: 1.00 PF, 2:16 PM
MIN: 0.11 PF, 11:58 PM

Phase B-N:

MAX: 1.00 PF, 2:16 PM
MIN: 0.51 PF, 5:49 PM

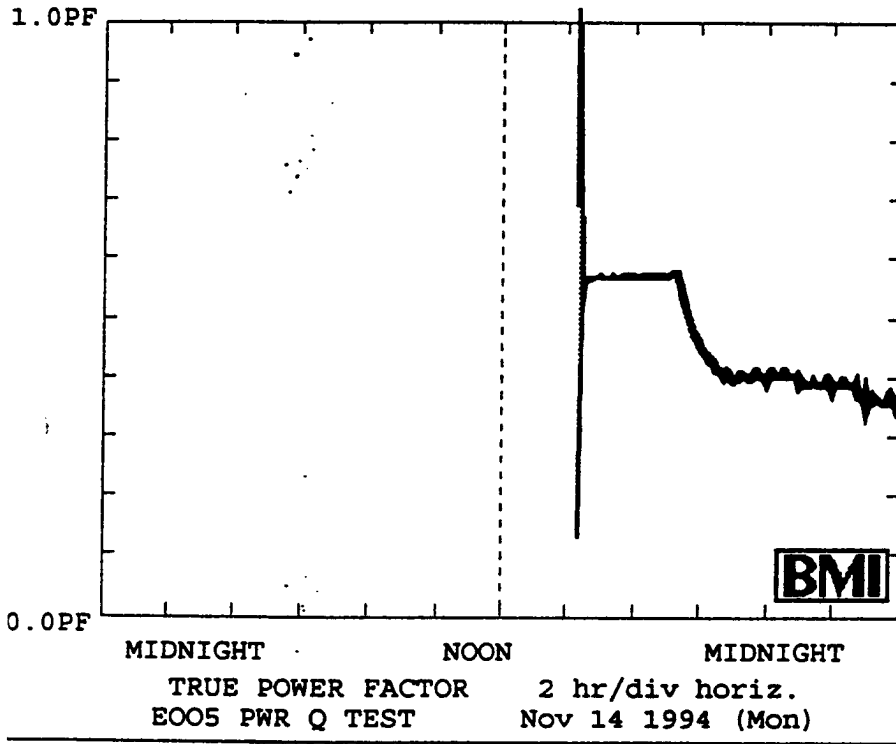

EOOS PWR Q TEST Nov 15 1994 (Tue)

VOLTAGE 12:02:43 AM

FROM: MIDNIGHT Nov 13 1994 (Sun)

To: MIDNIGHT Nov 14 1994 (Mon)

Average:

MAX: 126.9 V, 11:42 PM

MIN: 121.9 V, 5:15 PM

VOLTAGE IMBALANCE:

MAX: 0.7%, 10:15 PM

MIN: 0.1%, 11:45 PM

Phase A-N:

MAX: 127.2 V, 11:42 PM

MIN: 122.6 V, 5:15 PM

Phase B-N:

MAX: 126.6 V, 11:39 PM

MIN: 121.3 V, 5:15 PM

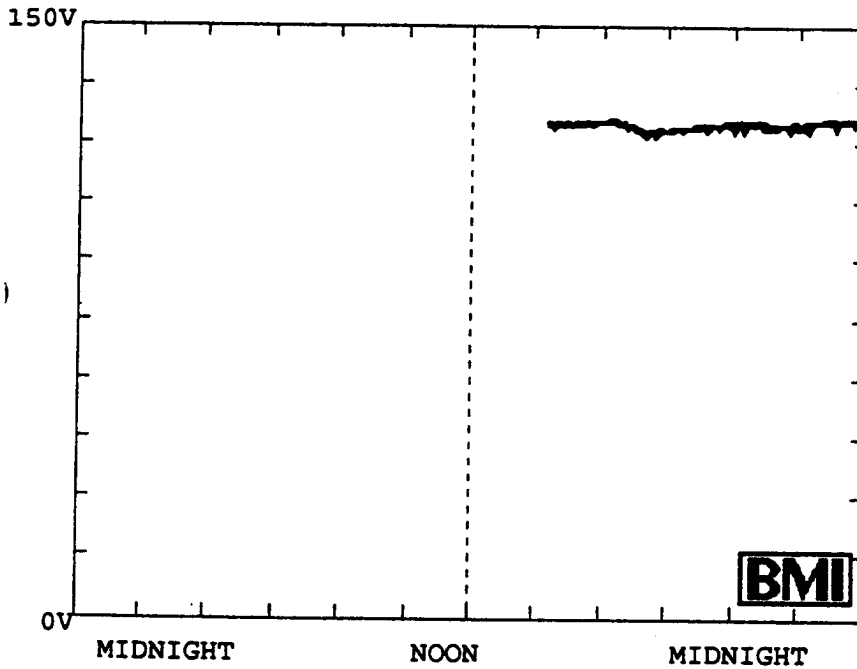

VOLTAGE 2 hr/div horiz.
EOOS PWR Q TEST Nov 14 1994 (Mon)

CURRENT

12:02:55 AM

FROM: MIDNIGHT Nov 13 1994 (Sun)

To: MIDNIGHT Nov 14 1994 (Mon)

Phase 1:

MAX: 34.5 A, 5:17 PM
MIN: 0.0 A, 2:16 PM

CURRENT IMBALANCE:

MAX: 0.3%, 9:58 PM
MIN: 0.0%, 7:32 PM

Phase A:

MAX: 17.2 A, 5:17 PM
MIN: 0.0 A, 2:16 PM

Phase B:

MAX: 17.3 A, 5:17 PM
MIN: 0.0 A, 2:16 PM

50.0A

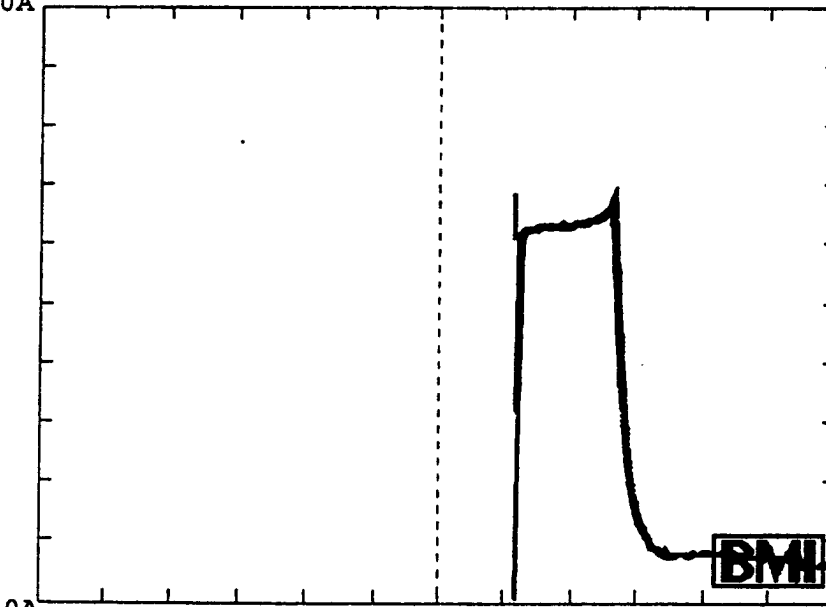

0A

MIDNIGHT

NOON

MIDNIGHT

CURRENT
EO05 PWR Q TEST

2 hr/div horiz.
Nov 14 1994 (Mon)

POWER QUALITY TEST
3 KILOWATT MENTZER CHARGER
WITH POWER FACTOR CORRECTION

7 E037

Nov 24 1994 (Thu)

INSTANTANEOUS POWER

12:00:01 AM

FROM: MIDNIGHT Nov 22 1994 (Tue)

TO: MIDNIGHT Nov 23 1994 (Wed)

Total:

MAX: 2.4 kW, 3:10 PM

MIN: -0.0 kW, 10:32 AM

Phase A-N:

MAX: 1.1 kW, 3:10 PM

MIN: -0.0 kW, 10:21 PM

Phase B-N:

MAX: 1.2 kW, 3:10 PM

MIN: -0.0 kW, 10:32 AM

+2.5kW

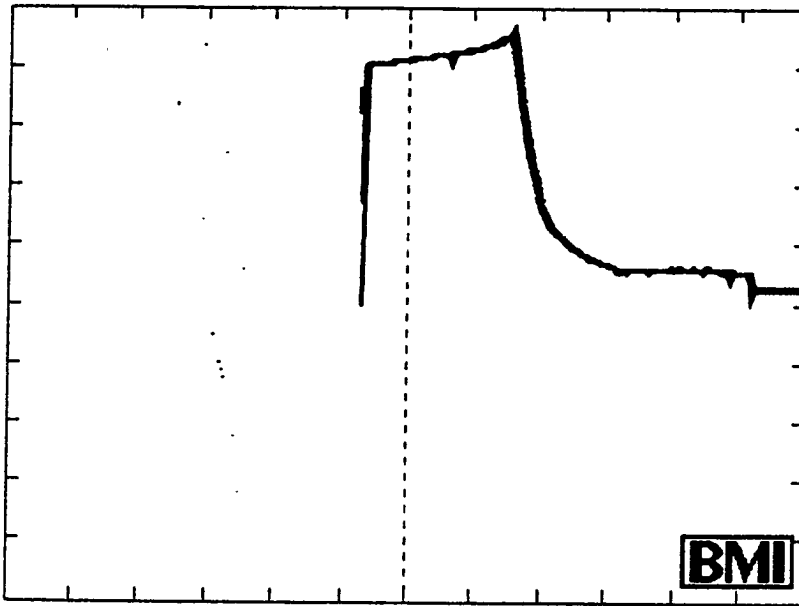

2.5kW

MIDNIGHT

NOON

MIDNIGHT

INSTANTANEOUS POWER 2 hr/div horiz.

EV E037

Nov 23 1994 (Wed)

Power factor corrected 3kw mentzer
 Location: Headquarters basement
 207V single phase

EV E037

Nov 24 1994 (Thu)

TRUE POWER FACTOR

12:01:02 AM

FROM: MIDNIGHT Nov 22 1994 (Tue)

To: MIDNIGHT Nov 23 1994 (Wed)

Total:

MAX: 0.87 PF, 11:05 AM
MIN: -0.18 PF, 10:32 AM

Phase A-N:

MAX: 1.00 PF, 10:32 AM
MIN: -0.19 PF, 10:20 PM

Phase B-N:

MAX: 1.00 PF, 10:32 AM
MIN: -0.27 PF, 10:32 AM

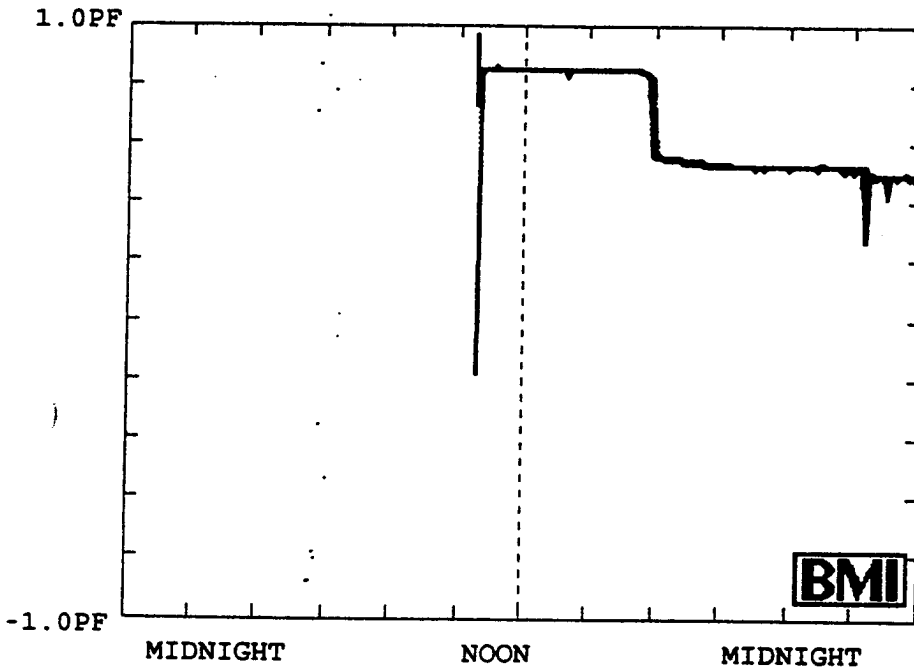

V E037

Nov 24 1994 (Thu)

VOLTAGE

12:02:45 AM

FROM: MIDNIGHT Nov 22 1994 (Tue)

TO: MIDNIGHT Nov 23 1994 (Wed)

Average:

MAX: 126.5 V, 11:51 PM

MIN: 122.3 V, 8:19 PM

VOLTAGE IMBALANCE:

MAX: 0.7%, 10:54 AM

MIN: 0.1%, 12:12 PM

Phase A-N:

MAX: 126.8 V, 11:51 PM

MIN: 122.8 V, 6:01 PM

Phase B-N:

MAX: 126.3 V, 11:52 PM

MIN: 121.5 V, 8:19 PM

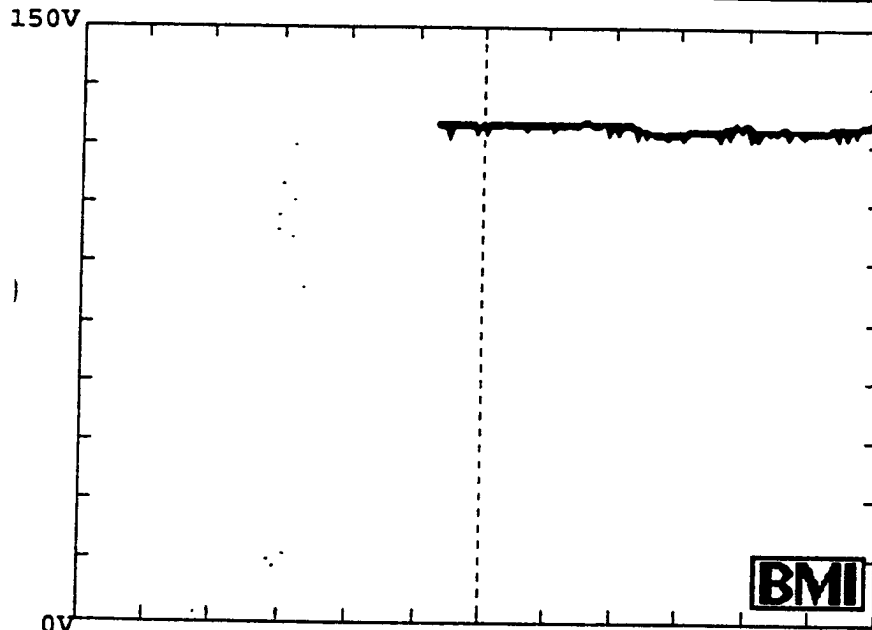

MIDNIGHT

NOON

MIDNIGHT

VOLTAGE
EV E037

2 hr/div horiz.
Nov 23 1994 (Wed)

POWER QUALITY TEST
HUGHES 6.6 KILOWATT INDUCTIVE CHARGER

IMPACT NO 48

Nov 10 1994 (Thu)

INSTANTANEOUS POWER

4:00:34 PM

FROM: MIDNIGHT Nov 09 1994 (Wed)

TO: MIDNIGHT Nov 10 1994 (Thu)

Total:

MAX: 6.4 kW, 10:21 AM

MIN: 0.0 kW, 2:56 PM

Phase A-N:

MAX: 3.4 kW, 10:21 AM

MIN: -0.0 kW, 2:56 PM

Phase B-N:

MAX: 2.9 kW, 10:21 AM

MIN: 0.0 kW, 3:28 PM

+10.0kW

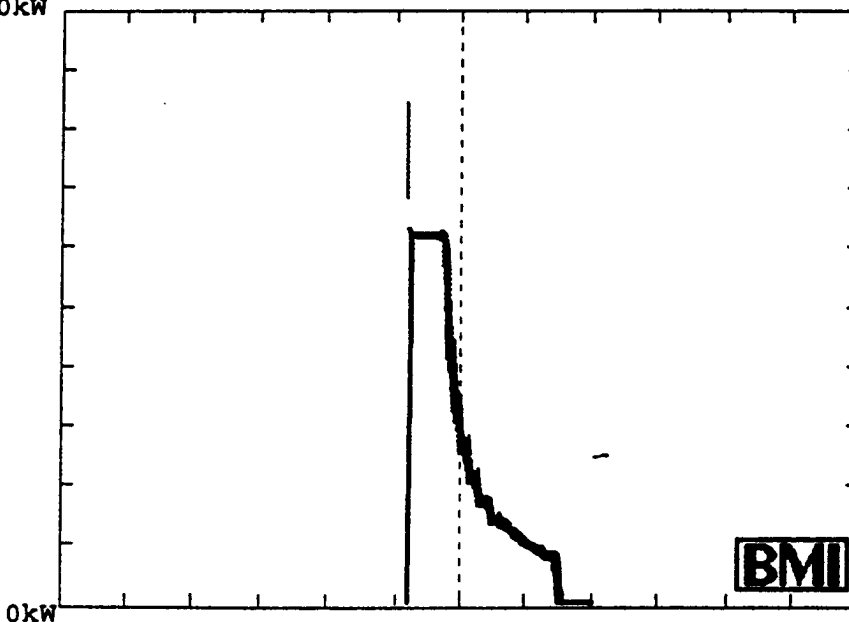

0kW

MIDNIGHT

NOON

MIDNIGHT

INSTANTANEOUS POWER 2 hr/div horiz.

IMPACT NO 48

Nov 10 1994 (Thu)

*Hughes Inductive charger
 Location GM Prevent-Drive Service Center
 208V single phase*

BMI 3030A

Basic Meas. Instruments

H-13

IMPACT NO 48 Nov 10 1994 (Thu)

TRUE POWER FACTOR 4:01:44 PM

FROM: MIDNIGHT Nov 09 1994 (Wed)
O: MIDNIGHT Nov 10 1994 (Thu)

Total:

MAX: 0.86 PF, 12:05 PM
MIN: 0.02 PF, 2:56 PM

Phase A-N:

MAX: 0.92 PF, 10:21 AM
MIN: -0.47 PF, 2:56 PM

Phase B-N:

MAX: 0.86 PF, 2:52 PM
MIN: 0.50 PF, 2:56 PM

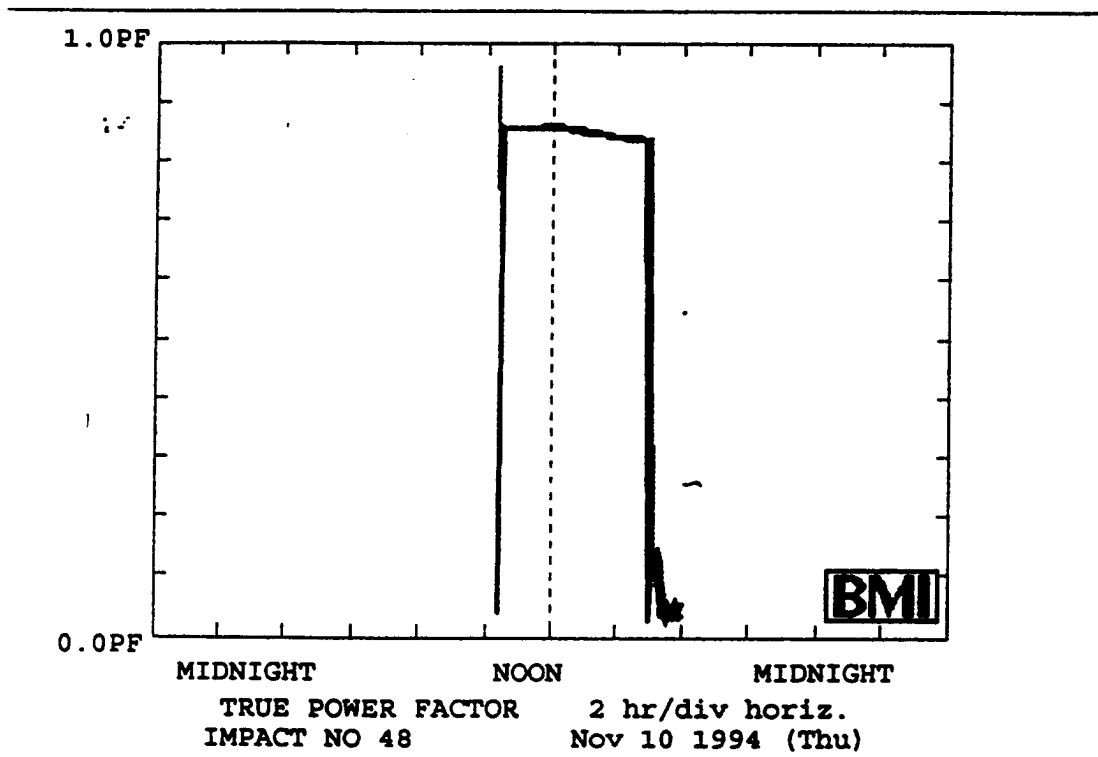

IMPACT NO 48 Nov 10 1994 (Thu)

VOLTAGE 4:03:28 PM

FROM: MIDNIGHT Nov 09 1994 (Wed)
To: MIDNIGHT Nov 10 1994 (Thu)

Average:
MAX: 123.1 V, 3:39 PM
MIN: 119.7 V, 10:43 AM

VOLTAGE IMBALANCE:
MAX: 0.5%, 11:27 AM
MIN: 0.0%, 2:48 PM

Phase A-N:
MAX: 123.3 V, 3:39 PM
MIN: 119.9 V, 12:47 PM

Phase B-N:
MAX: 122.9 V, 2:38 PM
MIN: 119.3 V, 10:43 AM

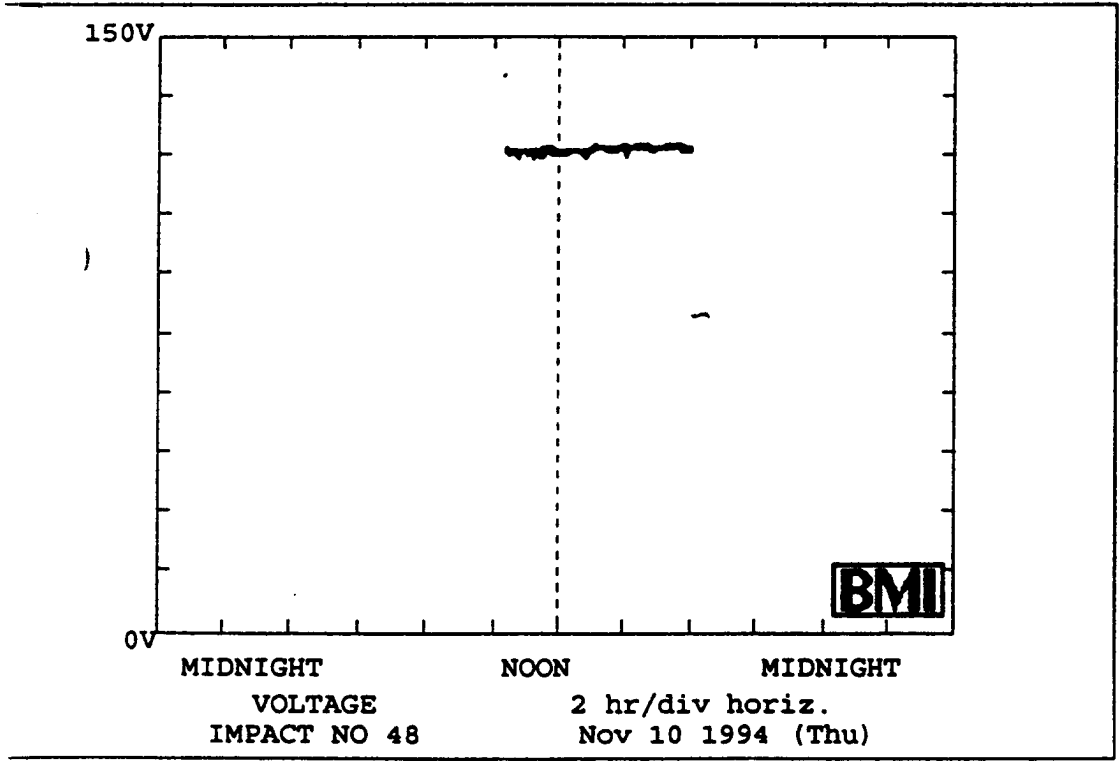

IMPACT NO 48

Nov 10 1994 (Thu)

CURRENT

4:03:41 PM

FROM: MIDNIGHT Nov 09 1994 (Wed)

TO: MIDNIGHT Nov 10 1994 (Thu)

Total:

MAX: 61.1 A, 10:21 AM
MIN: 1.0 A, 3:41 PM

CURRENT IMBALANCE:

MAX: 0.7%, 3:58 PM
MIN: 0.0%, 3:10 PM

Phase A:

MAX: 30.5 A, 10:21 AM
MIN: 0.5 A, 3:41 PM

Phase B:

MAX: 30.6 A, 10:21 AM
MIN: 0.5 A, 3:46 PM

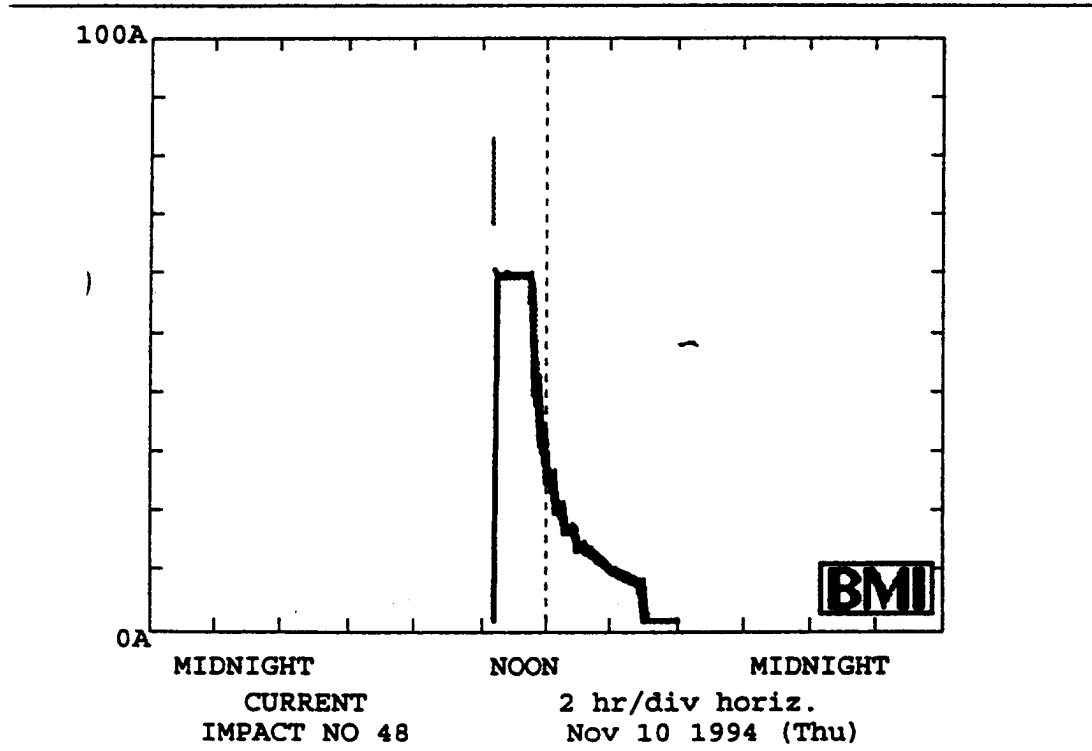

APPENDIX I

BADICHEQ CHARGE MANAGEMENT SYSTEM REPORT

Prepared By:

Sacramento Municipal Utility District

February 1997

BADICHEQ CHARGE MANAGEMENT SYSTEM REPORT

Table of Contents

<u>Section</u>	<u>Page</u>
I. OVERVIEW	I-3
II. FEATURES AND FUNCTION	I-3
A. Charge Control Feature	I-3
B. Equalization Feature	I-3
C. State of Charge (SOC) Gauge	I-5
D. Battery Monitoring	I-6
E. Battery Pack Diagnostics	I-7
F. Identifying Battery Pack Problems	I-14
III. INSTALLATION AND OPERATION	I-16
A. Installation Procedure	I-16
B. Configuration	I-17
C. Start-up Procedure	I-17
D. Calibration Procedure	I-17
E. Procedure for Conditioning a Battery Pack	I-19
F. Procedure for Replacing Batteries	I-19
G. Maintenance Procedure	I-20
IV. EXPERIENCE	I-20
V. HORIZON BATTERY PACK RESULTS	I-22
A. Analysis of Discharge Current Frequency	I-22
B. Overcharge and Overdischarge	I-24
C. Energy Efficiency	I-25
VI. CONCLUSIONS	I-25

I. OVERVIEW

Module-based battery charge management has been shown to prolong the life of sealed advanced lead acid batteries. Modules in a battery pack may have different capacities due to manufacturing differences, pack dynamics, and temperature differences within a pack. Individually controlling the charge of each battery is a method to optimize the capacity while preventing damage from overcharge. Electrosource recommended use of the Badicheq, the only battery management system available which met their desired charge control criteria at the inception of the field test project. The data collection feature of the Badicheq also allowed Electrosource to evaluate how the batteries were being used in electric vehicles.

The name Badicheq stands for Battery Diagnostic and Charge Equalization. The system was designed to perform the following functions:

- Control the vehicle charger using a variable 2kHz PWM signal to regulate current output with control based on individual module voltage to prevent overcharge of any one module in a pack.
- Provide an equalizing charge to modules that require it using a small integrated charger, Badicheq's proprietary software, and historic data to determine which batteries are of low capacity.
- Provide output of the pack state of charge, accurate to 5%, giving the user information for terminating the discharge.
- Monitor the voltage and temperature of up to 60 cells or modules in a battery pack and the current running through the pack.
- Collect and record battery pack data and provide the data in a diagnostic summary of 128 charge/discharge cycles which can be read using an RS232 interface and a PC.

II. FEATURES AND FUNCTION

A. Charge Control Feature - The Badicheq microcontroller contains the program to control the charge profile based on the battery manufacturer's specifications. The charge profile prescribed by Electrosource for the Horizon battery was a typical constant current, constant voltage, constant current (CV, CC, CV) charge profile (Version A). The charge profile was changed to a multi-step charge profile during the project (Version B), in which the bulk current was reduced by half each time the batteries reached a limiting voltage (called a clamp voltage), however, this profile was not successfully implemented into the charge control scheme and was discontinued after a short time.

Typically, a charger is controlled based on the value of the overall pack voltage. The Badicheq bases its control on the highest individual module voltage. This prevents overcharge of any individual module and those modules that are not fully charged during the main charge cycle receive individual charging during the Badicheq equalizing phase. The charger must be capable of responding to a 2kHz PWM signal received from the Badicheq for controlling the charge.

B. Equalization Feature - The purpose of the Badicheq equalizing charge is to keep the battery pack balanced by reducing the voltage spread from module to module. To do this the Badicheq provides preferential charge of a maximum 5 amps to as many as four chosen modules using a small integrated 20 watt charger. The Badicheq identifies which four, if any, modules to

equalize, by a computation based on the history of the individual modules in the battery pack. Badicheq must see a module delivering low capacity consistently (for 14 cycles) before activating the equalizing charge, a conservative approach which protects modules from being overcharged.

Over the course of the project, the manufacturer of the Badicheq made several revisions to the charging algorithm in response to the battery manufacturer's suggestions.

- Initially (in Version A), the Badicheq supplied a trickle equalizing charge during the first constant current phase ("I" phase) of charging of the CI,CV,CI charge profile and the multi-step profile.
- Later, an upgrade to the Badicheq algorithm implemented by newly programmed EPROM, added a second equalizing charge during the last "I" phase of charging (Version A-2). This second equalizing charge is activated when any module drops below 2.25 volts per cell (11.5 volts per module) and can continue as long as the vehicle is plugged in, effectively preventing the battery from suffering from self-discharge or parasitic losses.

Below is a graphic illustration of the equalization feature and its timing during the various charge phases:

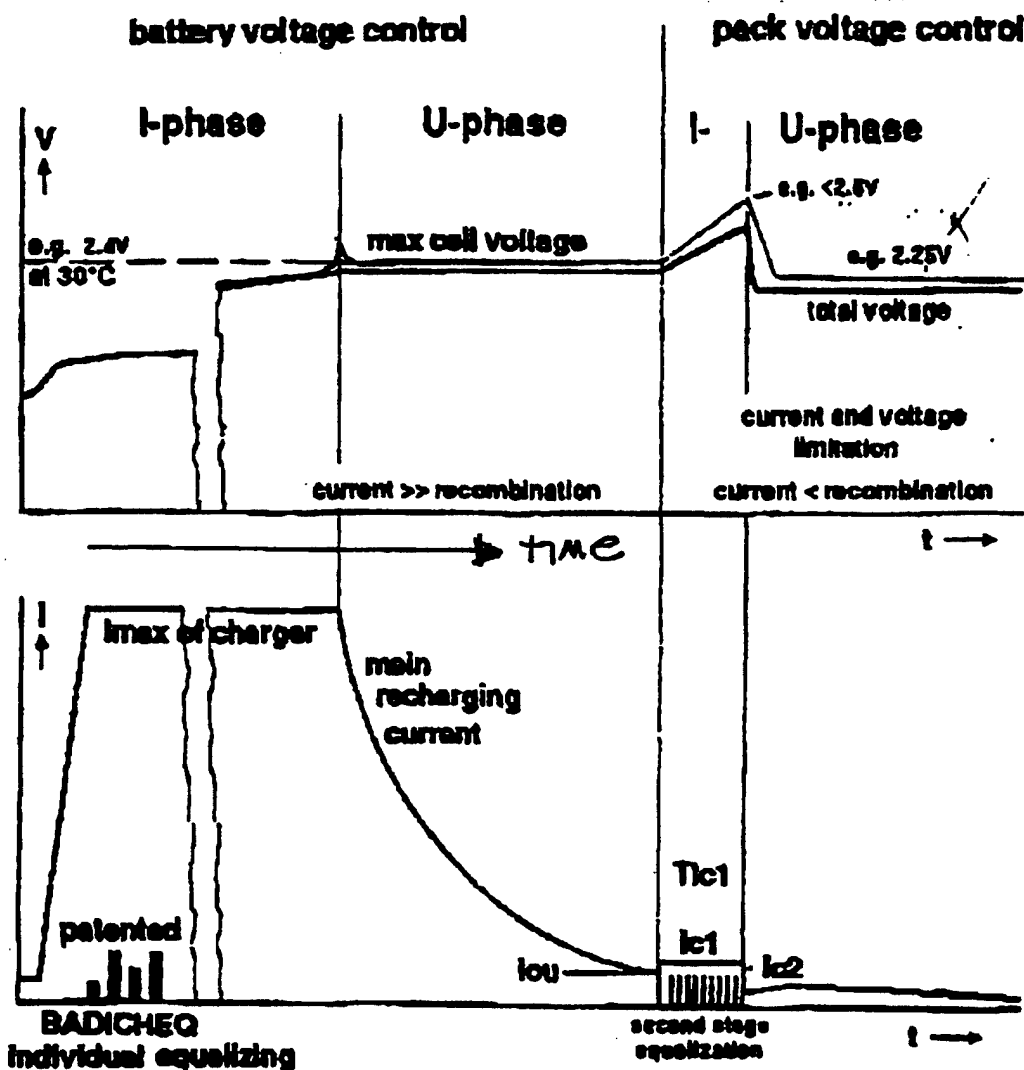

C. State of Charge (SOC) Gauge - To determine the SOC within a 5% accuracy, the Badicheq performs several calculations. It measures the voltages of each module, compensates for temperature of the battery, measures the discharge current once a second, and calculates amp-hours based on the measured rate of discharge and the peukert battery model. With this data, Badicheq then performs an elaborate computation, calculating the expected SOC based on the "reference capacity" of the battery pack.

This reference capacity (called Cref) is the 5 hour constant current discharge capacity for the particular battery, supplied by the battery manufacturer, and is programmed into the EPROM. Since battery capacity changes over its life, the reference capacity is updated by the Badicheq periodically, allowing the SOC determination to keep track of the changing capacity of a battery pack. This update occurs whenever a calibration procedure is performed on the battery pack (or sometimes naturally during a discharge as described in Section III D).

The capacity of a battery pack is limited by its lowest capacity module (limiting module), so the calibration procedure essentially finds the capacity of this module. Normally, the change in capacity experienced by a battery pack is gradual and the recalibration need only occur about every six months to assure that the SOC measurement remains fairly accurate. If the battery pack capacity changes dramatically for some reason, such as a short circuit in one of the modules, the Badicheq SOC algorithm recognizes the sudden change and tracks the new lower capacity of the pack.

The Badicheq system output also includes a series of status and warning lights indicating the following conditions:

<u>INTERPRETING THE LED WARNING LIGHTS:</u>		
<u>Color</u>	<u>LED</u>	<u>Meaning</u>
green	flashing	Charging the battery
green	steady	Charging complete
yellow	flashing	Capacity of the battery <15% - meaning the last 15% of usable capacity (100% SOC to 20% SOC)
yellow	steady	Voltage of 1 module <1.7 volts/cell
red	flashing	small error - such as high temperature
red	steady	significant error, service station must be contacted

The analog gauge which is the SOC output displays the status on a scale from Full to Empty (Empty being 20% SOC). A battery is at 20% SOC (80% depth of discharge) when 80% of its amp-hour capacity has been discharged. Even though voltage depression occurs when a battery is under a heavy load, the open circuit voltage (OCV) reliably falls at approximately the same level at various depths of discharge for a given discharge cycle. For the 3 hour constant current discharge (C/3), dynamic stress test (DST) or Federal Urban Driving Cycle (FUDS), the 80% DOD point is found at approximately 1.91 to 1.93 volts per cell or 11.5 volts per module (OCV) for the Horizon battery. In driving tests performed with the Badicheq's analog SOC gauge, this point was also reached when the SOC gauge reached Empty.

D. Battery Monitoring - The Badicheq system provides the ability to monitor and diagnose the condition of the batteries in present time. It is designed to monitor the voltage and temperature of each cell or module in a battery pack and the current running through the pack. It does this with a 16 gauge wire attached to the positive terminal of each battery module and routed to the Badicheq microprocessor. A temperature sensor is situated in each of as many as three discreet battery locations and a dedicated current shunt is wired in-line near the Badicheq.

Accessing the condition of the batteries is performed using Badicheq software on a remote PC interfaced with a D-SUB jack interface and an RS232 cable connected to the Badicheq. This can be performed safely when an isolated charger is used. However, when a non-isolated charger is used, the interface should take place only when the vehicle is unplugged. The Badicheq measuring cycle occurs about every four minutes at the beginning of a charge or discharge cycle and increases in frequency to approximately every minute as the battery approaches the upper or lower voltage limits.

Battery Data Retrieval - Battery data can be retrieved by PC at anytime during the cycle and viewed via command keystrokes. (At anytime, with ESC (escape), you can quit the screen and return to the Main Menu.) The keystrokes, which are case sensitive, are identified on the Main Menu Screen below:

- **m** - display actual cell voltages
- **g** - get data
- **p** - save data
- **v** - voltage history
- **V** voltage history graph
- **r** - recharge history
- **R** - recharge history graph
- **c** - charge throughput graph
- **e** - error history
- **l** - last cycle graph
- **s** - overall statistics

A description of the command keystrokes is provided in the following paragraphs:

“m” = Displays Actual Cell Voltages - The “m” screen shows the temperature compensated voltage readings of **all** the modules at the time that the “m” key is pressed. The “m” command can **only** be used when the PC is communicating with the Badicheq via an RS232 cable and the values cannot be stored in memory for later retrieval. Below is an example of the Cell Voltage Display:

1:2431	2:2430	3:2415	4:2440	5:2436	6:2402	7:2423	8:2427	9:2442	10:2445
11:2448	12:2412								

i. Voltage Readings - All voltages are read as millivolts per cell and must be multiplied by the number of cells in the module to find the module voltage. For example:

1933 mv per cell x 6 cells = 11.6 volts per module

2450 mv per cell x 6 cells = 14.7 volts per module

ii. Temperature Compensation - All the voltage readings whether viewed or recorded to memory, are not the actual voltages that would be measured by a voltmeter, but are temperature compensated. This adjustment reflects the change in capacity experienced at different temperatures. The temperature compensation factor is programmed into the Badicheq memory according to battery type:

- For Horizon 12N95 the adjustment is +/-5mv/cell per degree C above or below 25°C
- Example: an actual voltage of 1950mv when read at 5°C will be calculated as:
 $25^{\circ}\text{C} - 5^{\circ}\text{C} = 20^{\circ}\text{C}$ $20 \times (-5) = 100 \text{ mv}$ $1950\text{mv} - 100\text{mv} = 1850\text{mv/cell}$

The cell voltage will be displayed as 1850mv/cell. When the ambient temperature is at 5°C, the SOC gauge will not read "Full" even though the battery is fully charged, but will be downwardly adjusted according to this temperature compensation. This indicates to the driver that they have less than the usual capacity and allows them to plan their trip accordingly.

E. Battery Pack Diagnostics - The Badicheq system provides the opportunity to analyze historical data on the battery packs by viewing the cumulative statistics which the Badicheq collects and saves to memory.

Cycles - A Badicheq cycle is defined as either a charge or a discharge, therefore it takes two cycles for a complete "cycle" in the usual term used for battery life cycles. The Badicheq identifies charge cycles with an 'odd' number and discharge cycles with an 'even' number. For all historical data screens, the cycle number is listed on the far left. After writing 256 cycles to file (128 charges and 128 discharges) the Badicheq will begin writing over the first cycle. The cycle at the top of the screen is the latest available data.

Delay Between Cycles - There is a time delay after a charge or discharge begins before the Badicheq registers the cycle as an actual charge, for instance, rather than a long period of regenerative braking. At very low rates of charge or discharge the time before the "new cycle" is registered is longer than it is at high rates.

"g" - Get Data - This command allows the viewer to retrieve battery data from the Badicheq memory. Data from the latest cycle or from an existing (stored) file can be read after performing the "g" command.

"f" - Get Data from Disk - An "f" command, following a "g" command, allows the viewer to retrieve historical data stored under a particular filename.

"p" - Saving Files to Disk - Historical data is saved in numerical form only. To store graphic files of the latest cycle retrieved with the get data command (see "g" above) they must be saved using the "p" command. The following identification protocol was chosen for naming the saved files. The first three digits represent the vehicle identifier, and since Badicheq does not record mileage, we use the odometer reading and a C or D to represent charge or discharge. A typical file name is labeled as follows:

<u>Vehicle #</u>	<u>Odometer Reading</u>	<u>dot</u>	<u>Charge or Discharge</u>	
M01	4846	.	C or D	= M014846.D

“v” = **Voltage History** - The Voltage History screen displays the temperature compensated voltage on the top line and earlier cycles below it. The screen displays the six lowest or highest voltage modules, the best module and the average module in a pack for each charge and discharge cycle. This screen is updated periodically during a Badicheq measuring cycle.

When looking at historical data, it is important to know that the **final recorded voltage in a charge cycle** will be made at the time when the batteries reach their **first clamp voltage** at the end of the first Constant Current (I) phase of charging. The reason for this is that this voltage reading, recorded while charging at a high inrush current, is more significant than the higher voltages the batteries experience during the ‘very low’ final charge current (second I phase).

The **final recorded voltage in a discharge cycle** is the lowest voltage reached by the batteries during the discharge cycle, and not necessarily the final voltage. Very short voltage excursions are not recorded by the Badicheq on the Voltage History so that the technician does not misconstrue these readings but is only made aware of the more significant low voltage readings.

Following is an example of three cycles from a Voltage History screen:

VOLTAGE HISTORY File: M014846.D recorded: 21. 1.96										
Cyc!	Ba W0	Ba W1	Ba W2	Ba W3	Ba W4	Ba W5	Ba Best	Avg	QM	T
232!	12:1936	7:1943	6:1943	11:1946	10:1946	9:1946	2:1953	1946	43	0
231!	10:2395	5:2392	9:2386	12:2382	6:2382	7:2379	3:2291	2360	27	1
230!	12:1959	9:1966	10:1972	7:1972	5:1975	11:1979	1:2001	1979	25	0

Under column headings, the screen first identifies the cycle number, and then it identifies the battery number and voltage of the lowest or highest six modules in a battery pack (labeled W0, W1, W2, W3, etc. from left to right). At the right is best module and the average module as recorded at the end of the charge or discharge cycle (see note above). In the example given, for discharge cycle #232, the lowest battery is #12 at 1936 mv. It is the limiting module in the battery pack.

QM - The QM number is the charge throughput in percentage of the C/5 capacity (capacity at a 5 hour discharge rate). For a new battery pack, the C/5 capacity is initially the value provided by the battery manufacturer and programmed into the Badicheq software (via an EPROM) as the “Cref” value. This value is updated every time a “calibration” is performed on the battery pack. A calibration “teaches” the Badicheq the “new capacity” of the battery pack. (See calibration procedure).

“I” = **Last Cycle Graph or Cell Voltage/Cell vs. Charge Throughput** - The “I” graph is a graphic representation of the voltage and current during a charge or discharge cycle. The voltage graph on top displays three voltages, the maximum, the minimum, and the average voltage (not necessarily tracing the same module throughout the cycle). The lower trace shows the battery pack current during the charge cycle.

Below is an example of an "I" graph for a charge cycle:

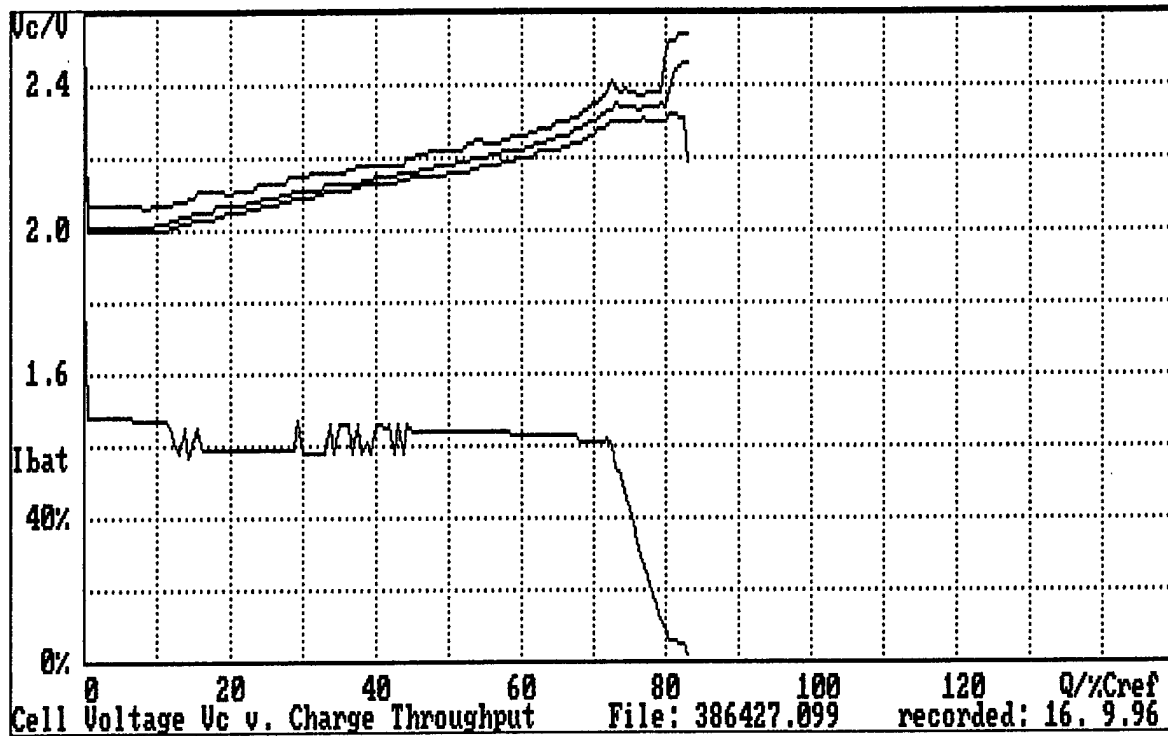

VOLTAGE HISTORY File: 386427.099 recorded: 16. 9.96

Cyc!	Ba	W0 Ba	W1 Ba	W2 Ba	W3 Ba	W4 Ba	W5 Ba	Ba Best	Avg	QM	T
99!	11:	2395	5:2382	9:2363	10:2360	6:2360	13:2356	1:2304	2350	80	1

RECHARGE HISTORY File: 386427.099 recorded: 16. 9.96

Cyc!	Ba:Mi	Ba:Mi	Ba:Mi	Ba:Mi	IMe.D	QM	QO	Q2	QD	Tpu	Tpo	TCy	TAc	Egy	EPRSNDOT
99!	2:60				3.0	80	2	0	0	25	40	28	128	93	01000001

The X and Y axis values on the "I" screen can be interpreted as follows:

i. The three traces on the top of the "I" graph are stated in volts per cell. They illustrate the high, average, and low voltages as the battery pack is charged.

ii. The Y axis in the lower trace of the "I" graph is stated as a percentage of a reference current as defined by the shunt values. In the example above, a current trace at the 60% level, (only the 0% and 40% level is labeled), represents a charge current of 10 amps. The charge current can be calculated as follows:

- we are using a 60mv 100amp shunt - $100\text{amps}/60\text{mv} = 1.66 \text{ amp/mv}$ factor
- the first I phase charge current is at 60% on the Y axis = $0.60 \times 1.66 \times 10 = 10 \text{ amps}$
- the second I phase charge current is <5% on the Y axis = $0.05 \times 1.66 \times 10 = 0.8 \text{ amp}$

iii. The X axis is stated in percent of capacity of the battery, full capacity being 100%. It is important to understand that the X axis of the "I" graph is related to capacity and not time so that

a particular phase of a charge may appear to be of short duration graphically because the capacity of charge delivered is small even though in real time it may take hours.

Following is an example of an "I" graph showing a discharge cycle:

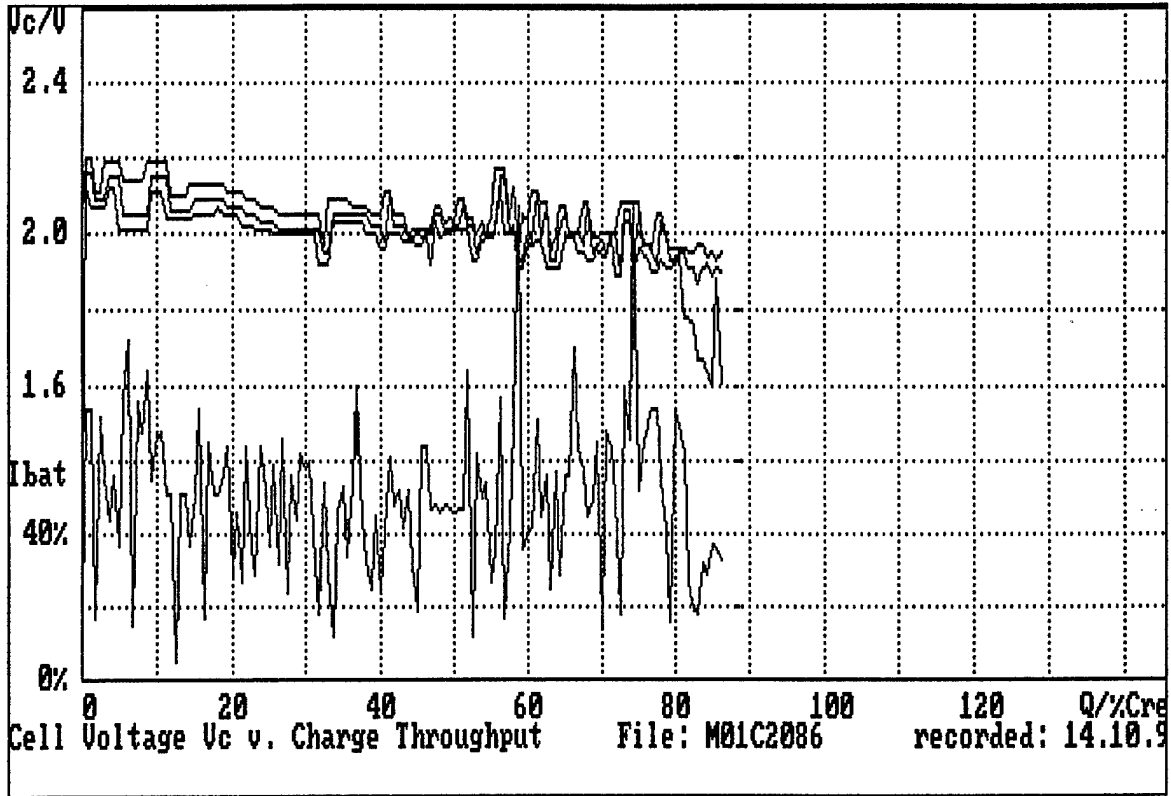

Use nearly the same criterion to interpret data from this discharge graph, except that discharge current is calculated by multiplying the IMe by only 1.66 (without the factor of 10). You can see that a battery voltage has dropped to 1600 mv at the end of discharge. The graph records every fluctuation, however, the recorded voltage (on the Voltage History below) is 1634 mv, because it remained at that voltage long enough for Badicheq to consider it significant.

VOLTAGE HISTORY File: M01C2086 recorded: 14.10.94										
Cyc!	Ba W0	Ba W1	Ba W2	Ba W3	Ba W4	Ba W5	Ba Best	Avg	QM	T
20!	11:1634	12:1816	7:1868	5:1868	10:1871	3:1881	9:1914	1865	86	0

RECHARGE HISTORY File: M01C2086 recorded: 14.10.94															
Cyc!	Ba:Mi	Ba:Mi	Ba:Mi	Ba:Mi	IMe.D	QM	QO	Q2	QD	Tpu	Tpo	TCy	TAc	Egy	EPRSNDOT
20!					-18.0	86	1	18	33	10	30	10	26	93	1000000

“R” = Recharge History - The “R” screen provides an abundance of information about the charge and discharge cycles. In the example below, four lines from a Recharge History (“R” screen) are shown with four lines from the corresponding Voltage History (“V” screen) also shown for reference:

RECHARGE HISTORY File: M0113621 recorded: 5.7.95															
Cyc!	Ba:Mi	Ba:Mi	Ba:Mi	Ba:Mi	IMe.D	QM	QO	Q2	QD	Tpu	Tpo	Tcy	Tac	Egy	EPRSNDOT
136!					-53.0	42	1	3	8	10	40	255	22	39	10000001
135!	3:40				6.0	58	0	0	0	10	35	67	151	69	01000001
134!					-12.0	34	0	0	12	5	30	255	16	38	10000000
133!	8:40	3:40			6.0	54	0	0	0	10	30	24	218	60	11000001

VOLTAGE HISTORY File: M0113621 recorded: 5.7.95											
Cyc!	Ba W0	Ba W1	Ba W2	Ba W3	Ba W4	Ba W5	Ba Best	Avg	QM	T	
136!	4:1601	10:1725	12:1897	9:1901	5:1910	7:1927	8:1992	1894	42	1	
135	2:2434	1:2428	11:2347	6:2343	9:2337	7:2307	8:2246	2327	58	1	
134!	4:1914	5:1927	6:1930	3:1930	1:1930	11:1936	12:1940	1933	34	0	
133!	2:2421	1:2347	6:2268	5:2262	9:2259	12:2255	3:2213	2268	54	1	

Cycle numbers against the left margin identify the charge and discharge cycles. Four columns titled “BaMi” identify up to four batteries that may receive trickle equalizing recharge. The amount of additional recharge is given in 20 minute increments:

- 0 means 0 to 19 minutes
- 20 means 20 to 39 minutes
- 40 means 40 to 60 minutes

In the example above, the #3 battery received 40 to 60 minutes of extra charge in cycle #135 and both #3 and #8 received 40 to 60 minutes of extra charge in cycle # 133.

Other information regarding charge current, overcharge, temperature, duration of the cycles, and errors are described below as identified by its column heading.

- **IMe** - The number in the “IMe” column indicates the nominal current, or rate of discharge, at the time of the latest Badicheq measuring cycle. This number is not stated in actual amps but is a percentage of a reference current related to the shunt size (as shown in the calculation on page 7). For most of the SMUD vehicles with a 60mv, 100 amp shunt, the actual discharge current can be derived by multiplying the “IMe” number by 1.66.
- It is important to consider this number when viewing the corresponding data from the “V” screen (Voltage History). For instance, a high negative “Ime” number refers to a high rate of discharge and the corresponding voltages on the “V” screen will be depressed. In the example above the “Ime” value of -53 ($-53 \times 1.66 = 88$ amps), represents a fairly high discharge current.
- The third and fourth lowest batteries and the average battery in the pack (all around 1894 to 1901 mv/cell) are at 84% DOD when the discharge current of 88 amps is considered. If the voltages dropped to those levels when the current draw was at 35 amps (Ime of 39) the battery would be at 95% DOD. The first two batteries at 1601mv and 1725 mv per cell at a discharge current of 88 amps are below 100% DOD.

- A zero (0) in the IMe column is the same as the open circuit voltage (OCV) and a relatively low negative "IMe" number, such as -3 is close enough to be interpreted as OCV. At those low rates, during a dynamic discharge, the voltage at 80% depth of discharge is about 1933 mv per cell.
- **QM** - charge throughput in % of the C/5 capacity - described above under "V" screen.
- **QO** - overcharge or over-discharge in % of C/5. This is an indication of very deep discharge below 1700 mv/cell or charge above 2500 mv/cell. The example on the previous page contains a number in the QO column of Cycle #136. It appears that even though two batteries were discharged very deeply, it amounted to only 1% of the capacity of the battery pack. A high QO value, like 10, is equivalent to about 10 amphours of overdischarge in a Horizon battery.
- **Q2** - Discharge below 20% of the C/5 value. This figure indicates discharge beyond the 80% DOD value. To use the example of Cycle #136 on page 9, the value in the Q2 column is 3. This is equivalent to about 3 amphours. Below is an example Recharge History (with Voltage History interjected) showing a battery pack with two cycles overdischarged and one cycle that is not overdischarged. The high value in the Q2 column in cycles #88 and #90 depict the overdischarge.

RECHARGE HISTORY File: M014846 recorded: 21. 1.96															
Cyc!	Ba:Mi	Ba:Mi	Ba:Mi	Ba:Mi	IMe.D	QM	QO	Q2	QD	Tpu	Tpo	TCy	TAc	Egy	EPRSNDOT
90					-21.0	71	10	18	6	15	20	4	24	66	10000001
90!	3:1686	12:1878	8:1881	10:1888	9:1904	6:1904	4:1962	1894	71	1					
88!					-21.0	51	18	18	6	5	20	31	50	99	10001001
88!	8:1178	3:1777	12:1910	10:1930	5:1930	9:1933	4:1949	1855	51	1					
86!					-6.0	38	0	0	21	5	30	1	6	35	00000000
86!	12:1949	10:1949	8:1953	11:1956	5:1956	9:1959	4:2067	1988	38	0					

- **QD** - dynamic charge in % of C/5. This is an indication of the amount of discharge that has occurred at a high rate of acceleration calculated differently from the QM value.
- **Tpu and Tpo** - is the maximum and minimum temperature in degrees Celsius experienced in the charge or discharge cycle. This includes the temperature change over the entire cycle (until the cycle changes direction (charge or discharge) *including idle time on the charger*). Although temperature sensors are very accurate and this accurate reading is used in calculating the temperature compensated voltage, the readings are rounded up or down to the nearest 5°C.
- **TAc** - the current length in number of six minute intervals. Since 6 minutes is one tenth of an hour, a reading of 59 = 5.9 hours, a typical charge length. This is the length of time that the battery is being actively charged or discharged.
- **TCy** - the cycle length in the number of hours up to a maximum of 255 hours. This is the full length of time between the beginning of the active cycle and the next active cycle. It can indicate how long the vehicle was left unplugged after it was driven and before it was

plugged in. The following example of data is from a G-Van driven every evening as an employee vanpool and charged everyday at SMUD:

1. For a charge cycle, if the TAc column = 35, then 35 x 6 min = 3.5 hours actively charging
 2. For a discharge cycle, if the TAc column = 10 = 10 x 6 min = 60 minutes of driving
 3. For a charge cycle, if the TCy column = 9 = 9 x 60 min = 9 hours on the charger
 4. For a discharge cycle, if the TCy column = 15 = 15 x 60 min = 15 hours off the charger, either driving or idle
 5. The typical cycle for the G-Van is that it was plugged in and actively charged for 3.5 hours at work. It then continued to sit idle on the charger during the workday, completing its 9 hour cycle on the charger, then was driven to an employees home for 30 minutes and did not move again until the next morning when it was driven 30 minutes to work again, completing a total of an hour of active driving. This was 15 hours from the time it was last charged, so it the discharge cycle was 15 hours long.
- **Egy** = a percentage (%) of the kWh throughput during the cycle. Using this number you can arrive at an approximation of the kWh used in the cycle by multiplying by the nominal pack voltage of the vehicle:

- Example = G-Van at 216 volts x Egy of 48 = 10.4 kWh charged

RECHARGE HISTORY File: M014990 recorded: 2. 2.96															
Cyc!	Ba:Mi	Ba:Mi	Ba:Mi	Ba:Mi	IMe.D	QM	QO	Q2	QD	Tpu	Tpo	TCy	TAc	Egy	EPRSNDOT
99!					6.0	46	0	0	2	5	30	48	200	48	11000001

Of the letters EPRSNDOT heading the right hand column above, only a few have been observed during the test project:

- **E** = denotes that errors have been identified during the cycle
- **P** = denotes that the Badicheq controlled the charger during the cycle
- **N** = denotes that the Badicheq has been disconnected during the cycle - important in troubleshooting because the Badicheq can give false readings for a cycle when re-connected after being disconnected.
- **T** = denotes that all charging phases have been completed.

“c” Screen - Charge Throughput Graph - This graph provides a “snapshot” view of the last 128 charge and discharge cycles. The vehicle duty cycle and typical percentage of capacity used is apparent from this screen. Below is an example of the “c” screen.

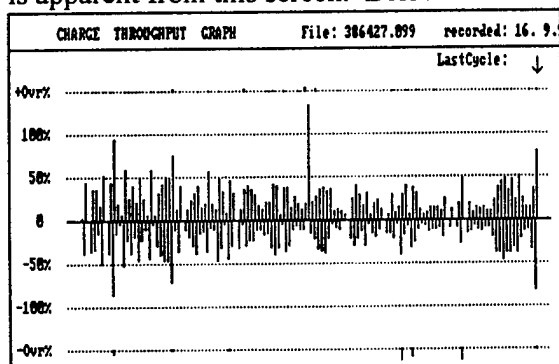

Demonstration Vehicle - irregular trips

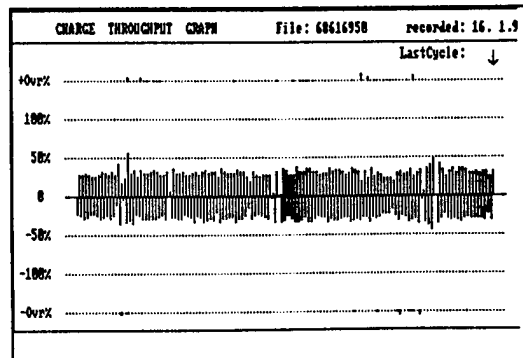

Employee Van Pool - routine trips

“e” Screen - Error History - The Error History lists any error messages with the corresponding cycle number. Below is an example of an Error Screen (“e”) and a listing of the most common error codes:

25	- supply voltage is too low (total pack voltage)
6	- discharge below 1.7 volts / cell on one module, deep discharge
22	- error with temp sensor 1-3
28	- total voltage is too high (overcharge)
7	- the integration of charges has passed the max. value (overflow)

“s” Screen - Battery Overall Statistics - The top of this screen shows the cumulative statistics for the vehicle and is used for a quick diagnostic check on how the battery has been treated. Following is an example from G-Van #686:

BATTERY OVERALL STATISTICS - G-Van #686	
<u>From Badicheq Screen</u>	<u>SMUD Analysis</u>
Number of cycles : 268	<i>in roundtrip cycles (134 discharges)</i>
Number of overcharges : 33	<i>33 charges slightly over 2.45 volts per cell</i>
Number of total discharges: 2	<i>2 discharges to 100% DOD</i>
Number of >80% discharges: 10	<i>10 discharges over 80% DOD</i>
Total charge/CRef : 38.99	
Total overcharge/CRef : 0.45	<i>very little overcharge (.45/38.99 = 0.01%)</i>
Total discharge/CRef : 39.10	<i>39 actual discharge cycles on the battery</i>
Total deep discharge/CRef : 0.6	<i>very little total discharge (.06/39.10 = 0.002%)</i>
Total >80% discharge/CRef : 0.35	<i>very little overdischarge (.35/39.10 = 0.009%)</i>
Total input energy/ERef : 78.84	
Total output energy/ERef : 68.38	<i>battery charge efficiency is 68.38 / 78.84 = 87%</i>

“s” Screen - Driving Attitude - The bottom portion of the Battery Overall Statistics screen shows the battery current during the total driving time. The battery current is divided into 8 sections. During each drive it is recorded how often the current falls within one of the sections where this statistic is stored and displayed. A comparative analysis of the driving attitude can be performed to analyze effects of vehicle design and driver training.

“V” Screen - Voltage History Graph - This screen accessed with a “capital V” gives a graphic view of individual modules which are discharged over 80% DOD.

F. Identifying Battery Pack Problems

Identifying Bad Modules - Consistently bad battery modules can be identified graphically using the “V” chart accessed on the main menu. The modules which are discharged beyond 80% DOD are shown as a dark rectangle to the right of the number. The purpose of this graphic is to spot trends. In the example below, batteries #9, #10, and #12 were consistently being overdischarged. Battery #10 was replaced at cycle #150 and the improvement is evident:

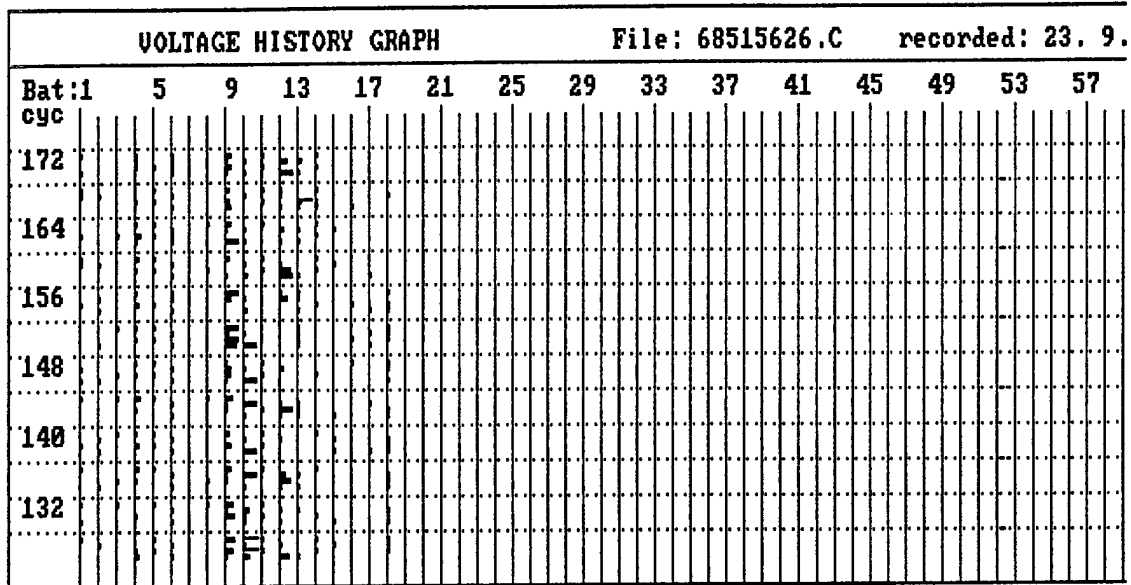

Determining Voltage Spread - One observation that can be made from the Voltage History screen are an indication of voltage spread, by comparing the worst, the best and the average modules in a pack. The following example of an unbalanced battery pack and a balanced battery pack. The unbalanced pack shows a voltage spread of about 350 mv per cell or 2.1 volts between the lowest and highest module. The corresponding graphic screen (L screen below) shows three distinct lines.

Cyc!	Ba W0	Ba W1	Ba W2	Ba W3	Ba W4	Ba W5	Ba Best	Avg	QM	T
137!	1:2421	2:2395	6:2366	11:2333	5:2324	9:2314	4:2073	2291	98	0
	worst module (2421mv)		best module (2073mv)			average module (2291 mv)				

- **Balanced Battery Pack** - A close relationship between the worst, best, and average modules is an indication of a well-balanced battery and is illustrated with the voltage history and graphic below:

VOLTAGE HISTORY										
File: 0376174C recorded: 24. 8.95										
Cyc!	Ba W0	Ba W1	Ba W2	Ba W3	Ba W4	Ba W5	Ba Best	Avg	QM	T
157!	4:2379	2:2379	1:2360	11:2343	3:2340	5:2337	7:2311	2337	70	0
	worst module (2379mv)		best module (2311mv)			average module (2337mv)				

Only 68mv/cell difference or total of 0.4 volts per module as illustrated by the graphic below:

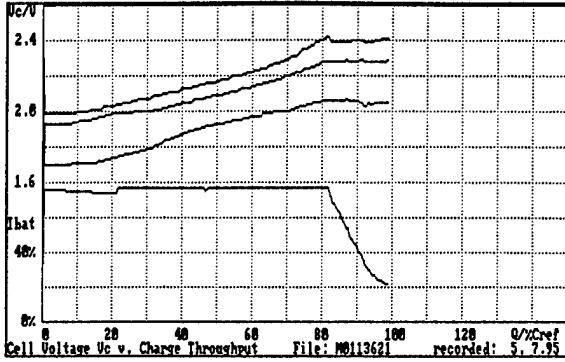

Unbalanced battery pack

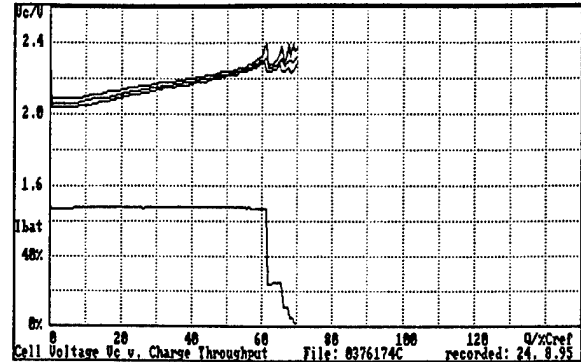

Balanced battery pack

Determining Battery Capacity - Battery pack capacity can be determined best by calibration procedure (discharging the pack to 100% DOD at the 5 hour rate - described under Calibration Procedure, Section III-D). This operation is very time consuming. A way to estimate the capacity by looking at the data is by adding the QD and QM numbers when the pack has been discharged to about 80%DOD. Following is an example of this determination on a G-Van pack just before and just after replacement:

RECHARGE HISTORY File: 68616600.D recorded: 12.12.96												
Cyc!	IME	QM	QO	Q2	QD	Tpu	Tpo	TCy	TAc	Egy		
		QM	QD								<i>calculation</i>	<i>Avg</i>
102!	-3.0	46	0	6	17	10	15	5	11	46	$46 + 17 = 63$	1943
												Ba W0 Ba W1 Ba W2
												13:1923 7:1927 12:1930
100!	3.0	40	0	3	17	10	15	1	8	38	$40 + 17 = 57$	1943
												7:1923 13:1933 12:1933
98!	-3.0	36	0	0	15	10	15	3	9	36	$36 + 15 = 51$	1953
												7:1943 12:1946 8:1946
New pack installed here												
80!	-18.0	28	1	0	8	10	20	63	8	28	$28 + 8 = 36$	1881
												13:1425 2:1858 9:1861
78!	-6.0	20	0	0	6	15	20	15	7	19	$20 + 6 + 26 = 52$	1979
												13:1936 16:1969 9:1969
76!	-31.0	26	0	0	7	10	20	39	9	29	$26 + 7 = 33$	1940
												9:1829 16:1907 13:1907
74!	-3.0	26	0	0	8	15	20	15	6	26	$26 + 8 = 34$	1988
												13:1901 14:1982 10:1982
72!	-3.0	26	0	0	10	15	25	64	8	26	$26 + 10 = 36$	1946
												13:1933 16:1936 10:1936

It can be derived from this example that for Cycles #72 through #80, battery pack capacity had declined to around 35 amp hours or half of the 70 amp hours that might be expected out of an 80% DOD discharge from this battery. The battery pack was replaced and the new battery pack, Cycles #98 through #102 are showing capacity increasing as the battery pack goes through its conditioning cycles. (See procedure for conditioning a battery pack - Section III.E.)

III. INSTALLATION AND OPERATION

Following is a description of the installation and operation procedures for the Badicheq:

A. Installation Procedure - The Badicheq distributor supplied most of the parts necessary for installation of the Badicheq, including the D-SUB connector, 35 pin AMP-jack, crimp contacts, cables in 2, 4, and 6 meter lengths for the following: temperature sensors, shunt cables, display cables, charger cables. A choice of 60mV shunts in 60, 100, 150, 200 amp values are

used. The shunt was installed at the negative end of the battery pack so that all power is measured that goes through the battery pack. Each battery was wired into the Badicheq by its positive terminal.

The first installation of a Badicheq was performed by the distributor's representative and training was provided so that subsequent installations could be performed in-house. The installation procedure was followed carefully to assure that the Badicheqs were wired properly and no wiring problems have occurred in the program.

B. Configuration - It is necessary to provide to the Badicheq distributor the vehicle and battery configuration before ordering the Badicheq. The parameters are the battery type, number of batteries, shunt size, number and length of temperature sensors, location of temperature sensors, type of display (analog or digital). This information is programmed into the Badicheq's EPROM memory and must be changed if any of the parameters change. The configuration of the seven vehicles field tested over the course of the test project are listed in the table below:

	Solectria Force	Horlacher P-I	Horlacher P-II	Horlacher Sport	G-Vans
Battery type	Horizon 12N95	Horizon 12N95	Horizon 12N95	Horizon 12N95	Horizon 12N95
No. of batteries	12	12	14	12	36 in parallel
Shunt size	100a/60mv	100a/60mv	100a/60mv	100a/60mv	200a/60mv
Temperature sensors - #'s	Front: 1 - 6 Back: 7-12	Front: 1 - 4 Back: 5-12	All: 1 - 14	Front: 1 - 6 Back 7-12	All: 1 - 18
Cable length	front-short back-long	front-short back-long	short	front-short back-long	long
Charger	Mentzer	Mentzer	Brusa	Mentzer Cube	CEN and Mentzer
EPROM Vers.	A-2	A	A-2	A-2	special
DISPLAY	analog	digital	analog	digital	analog

C. Start-up Procedure - Each newly installed battery pack, Badicheq, or charger must be monitored by a PC and test driven to assure that it is functioning properly. The display should be checked for accuracy. Several new chargers or EPROMS containing a new charger algorithm were integrated as part of the project. The first charge cycle was always carefully observed to assure that it was under control of the Badicheq knowing that an uncontrolled charge could result in excess gassing and loss of electrolyte. This control can be verified by a "flag" under the "P" column in the Recharge History ("R" screen), and by seeing that the bulk charge current decreases to about 1 amp after the first battery voltage reaches 2450 mv per cell.

D. Calibration Procedure - To properly calibrate a Badicheq requires a load bank or battery cyler capable of discharging the battery pack at a C/5 rate. Prior to a calibration cycle, the vehicle needs to be discharged at least 30% so that a full charge takes place and a T-flag is obtained. The vehicle was charged close to where the calibration cycle was to take place. Using a resistive load, the vehicle is discharged at a constant current equal to the C/5 rate until at least one module reaches 1.70 volts per cell. When this occurs, the blinking yellow LED low battery warning becomes a constant yellow light. This must remain constant for at least 10 seconds,

then it is time to stop the discharge. A successful calibration is also indicated by accessing the "m" screen and seeing the actual battery voltages, one of which will be below 1.70 volts/cell.

Once the calibration is confirmed, the vehicle should be plugged in and allowed to charge uninterrupted until full (a solid green light). The charge after the calibration will indicate a T-flag also for the calibration to be effective, but this can only be detected after the subsequent discharge begins and the Badicheq makes its final update on the charge cycle. When calibrating a fully conditioned battery pack, the capacity measurement or QM should reach 100. These parameters must exist for a successful calibration of the Horizon Model 12N95:

- a full charge has occurred previous to the calibration indicated by a T-flag (Note: the T flag cannot be observed on the charge cycle until after the first measuring cycle occurs on the subsequent discharge cycle)
- a fairly constant discharge is performed at a C/5 rate (C/3 will also work)
- the limiting battery is discharged to 1.70 volts per cell
- a full uninterrupted charge occurs after the calibration

Following is a calibration cycle which stops when the lowest battery reaches 1.7 volts/cell:

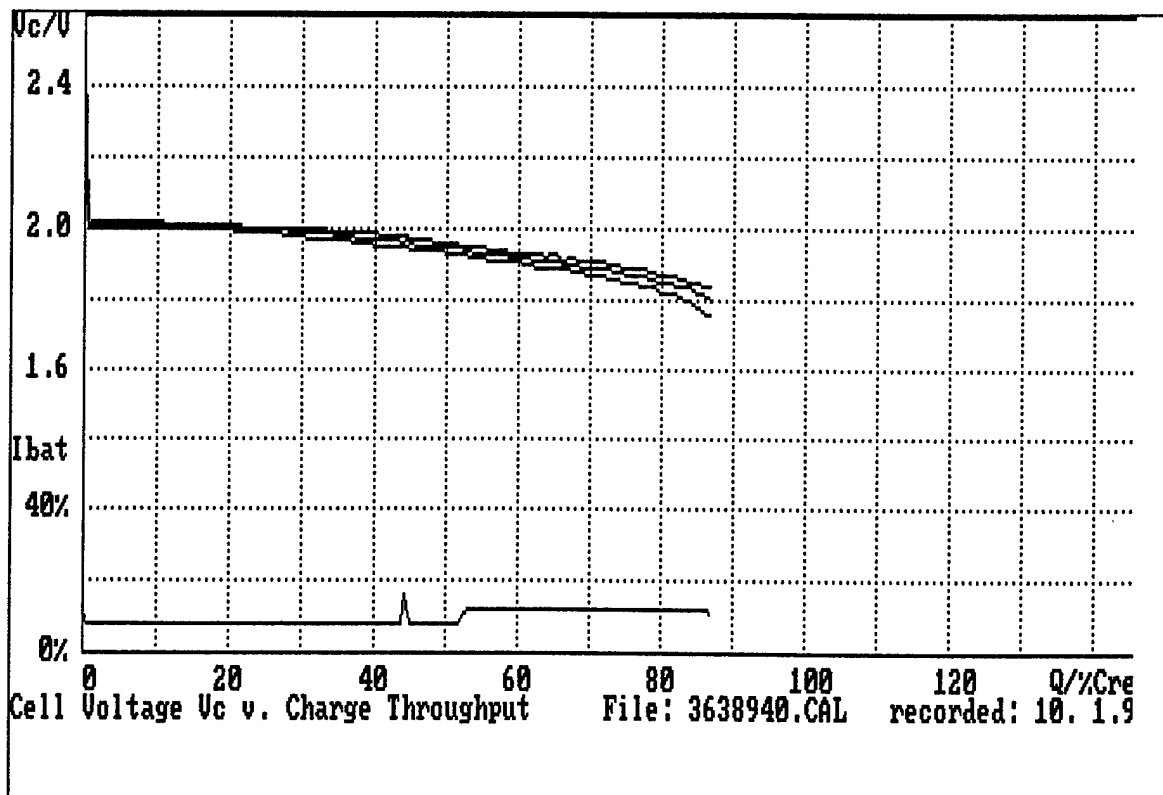

The most recent calibration is the basis of the capacity determination by the Badicheq as reflected on the SOC gauge and in the QM calculation. This will continue to be used until another calibration takes place. If the battery pack capacity is in a state of flux, growing or declining rapidly, the calibration needs to be repeated frequently, approximately every 25 or 50 cycles for accurate indication of state of charge. Under certain conditions, a vehicle will calibrate automatically while it is being driven. These conditions occur when, during a drive,

one module has been discharged down to 1.70 volts per cell and the previous and subsequent charge cycles are complete.

E. Procedure for Conditioning a Battery Pack - The following procedure was devised for breaking in new battery packs during the project. The first three to five discharges are driven gently, (i.e. non-highway drives with easy accelerations). A portable computer was used to periodically collect the Badicheq data and observe the progress of each discharge. While watching the Voltage History, the vehicle was driven until the lowest module reached 80% DOD at about 1910 to 1930 mv/cell (when the "Ime" number on the corresponding Recharge History screen was zero (0) or minus 3 (-3) (See caution under Section II.E. - Voltage History).

If the batteries are not pre-conditioned, the first drive on a new battery pack typically results in only about 50% to 75% of the expected range of the vehicle, so care must be taken to calculate the distance of the turn-around point and to drive within a couple of miles of the charging location when approaching 80% DOD. Each subsequent cycle will result in a slightly higher range and higher QM, often increasing as much as 10% each cycle. By the fifth cycle the QM is about 75 if the temperature is about 77°F and at this point the range should stabilize. A calibration is performed before placing the vehicle in service.

VOLTAGE HISTORY File: M014846 recorded: 21. 1.96										
Cyc!	Ba W0	Ba W1	Ba W2	Ba W3	Ba W4	Ba W5	Ba Best	Avg	QM	T
240!	12:1929	10:1936	9:1936	7:1936	11:1940	5:1940	3:1969	1940	54	0
239!	9:2399	4:2395	1:2369	12:2360	10:2360	5:2356	3:2285	2353	54	1
238!	12:1930	9:1933	10:1936	7:1946	4:1946	6:1949	1:1982	1946	52	0
237!	1:2412	2:2382	9:2369	10:2356	8:2353	5:2350	4:2307	2350	48	1
236!	10:1920	7:1920	12:1923	11:1927	9:1927	8:1927	3:1959	1933	44	0

F. Procedure for Replacing Batteries - A module is a candidate for replacement if its capacity is widely different from the rest of the pack and therefore limits the overall pack capacity. It can usually be identified on the Voltage History ("V" screen) showing up on the left side of the screen constantly as the lowest voltage battery on discharge and the highest voltage battery on charge. This indicates that it has the least capacity. It is usually a module that has repeatedly received additional equalization charge (as indicated on the Recharge History) but has not responded.

Successfully replacing a battery in an existing pack is difficult without either pre-conditioning the new module or monitoring the batteries during the initial discharges which act as conditioning cycles. The following procedure is used for replacing one to four bad modules in a battery pack of twelve sealed batteries with a Badicheq. If more than four modules are bad it is recommended that the entire pack be replaced. Replacement is only attempted after the battery pack in the vehicle has been fully discharged and then fully charged. Following is the complete procedure:

- The weak battery can be discharged as low as 9 volts under load as long as none of the others go below 1.75 volts/cell.
- Fully charge the vehicle.
- To replace the bad module, we move an existing battery into the spot where the bad one was and place the "fresh" module into the new open position.
- The vehicle is then driven for five conditioning cycles as described above until the "fresh" module reaches 80% depth of discharge (while driving the vehicle gently, watch that the cell

voltage on the new module does not go below 1.933). These five cycles should help to condition the new module.

- The Badicheq must be recalibrated at this point to protect the new battery module from overdischarge. It may still limit the battery pack capacity for some time before it is fully integrated into the pack.
- Repeat the calibration procedure after 25 or 50 cycles.

G. Maintenance Procedure - The change to sealed lead acid batteries have reduced the necessary maintenance dramatically. The battery pack does require some oversight to assure that it is running properly.

Diagnostic Check - Once a month, the Badicheq is downloaded and the technician makes the following observations:

- Are there any error codes, such as low battery, low pack voltage, etc.?
- Are any voltages dropping below 1910 mv/cell on the "V" screen?
- On the "S" Screen:
 - Is the total number of overcharges or undercharges excessive?
 - Is the total quantity of overcharge or undercharge excessive?
 - Does the energy efficiency calculation remain good (75% to 85%)?
- On the "L" screen for a full discharge or charge cycle:
 - Is a battery dropping out?
 - Is there excessive voltage spread?
- On the "R" Screen:
 - Has a module been repeatedly receiving additional charge and not responded?

Calibration - A calibration should be performed every six months. If the battery pack is less than 80% of its rated capacity, it should be considered for replacement. A decision should be made regarding whether it fits the mission and whether there has been an increasing incidence of module failure.

IV. EXPERIENCE

Pack Integration Experience - SMUD installed a Badicheq in each of the seven Horizon battery field test vehicles with generally good results. The Badicheqs are robust and never failed on a vehicle or during installation. Problems were encountered in interpreting the data from the Badicheq diagnostics screens and in the numerous changes in charging configuration that were implemented as part of the program. Following is a discussion of the problems that occurred:

Charge Algorithm Changes - Several changes to the charge profiles took place over the course of the project, to implement changes required either by Electrosource or Badicheq. Viewing the graphs provided the easiest way to verify the correct charge profile when integrating a new charger or charge algorithm. The various charge profiles are listed below:

<u>Version</u>	<u>Profile</u>	<u>Equalization</u>	<u>Date</u>
Version A	CI, CV, CI	equalization at 1st "I" phase only	8/94 - 10/95
Version B	multi-step	equalization at 1st "I" phase only	10/95 - 1/96
G-Van	special	allowed the CEN/Mentzer combo	???
Version A-2	CI, CV, CI	equalization at 1st and 2nd "I" phases	1/96 to present

New Charger Integration - Each time a new charger or charge profile was introduced, it was necessary to watch the first charge to assure that everything was functioning properly. There were many times when problems were discovered during this first charge cycle. This was evident from observing the graphic of the charge cycle ("I" screen) and noticing that the trace showing the current was not at an appropriate level, or noting from data in the Recharge History ("r" screen) that the charge was not properly controlled by the Badicheq.

1. In introducing a new Mentzer "cube" charger, the constant voltage portion of the charge profile was very erratic and the initial EPROM program had to be corrected.
2. The Brusa charger had several problems either with the control (PWM) cable interface, or with "noise" which interfered with the voltage reading by the Badicheq.

Multi-step Charge Profile - Implementation of the multi-step profile was troublesome. The multi-step profile is designed to reduce charge current by half every time the batteries reached 2450 mv per cell. It was not clear from the beginning that this was occurring and it was eventually discovered that the batteries were being undercharged because the charge was finishing prematurely.

G-Van Configuration - For the G-Vans converted to Horizon batteries, it was necessary to create a whole new charge profile EPROM. This EPROM attempted to carry out the bulk charge with a combination of the CEN charger (originally supplied by Conceptor with the G-Van) and the Mentzer charge, but with second "I" phase charge only supplied by the Mentzer. Several iterations were tried, but the right combination was not found until the CEN charger was adjusted so that it had a lower voltage threshold for end of charge. This compelled the CEN charger to shut down safely below any overcharge condition. The remaining charge was carried out by the Mentzer charger completely controlled by the Badicheq.

SOC Gauge Change - The Badicheq SOC gauge originally used in the project was a digital gauge. This provided a 4 digit number of which 2 digits represented the current and the other 2 digits represented the "QM" or % of reference capacity remaining. This was difficult for most drivers to understand and these were changed to the analog gauge when that new display became available.

Lack of Calibration Equipment - An automatic discharge device would be ideal for performing a calibration. As this was not available, the calibrations had to be performed manually, which was time- and space-consuming and was therefore not performed often enough.

Understanding the Badicheq Outputs - Reading the Badicheq screens has never been intuitively easy and required many months of observation before being able to understand them. The screens are not designed for the ordinary user, but for a trained technician or engineer. An adequate instruction manual was not supplied until early 1996.

The steep learning curve necessary for using the Badicheq was complicated by the problems experienced with the Horizon batteries and the chargers, making it difficult to tell if the problem was in the Badicheq, the battery, or the charger. This was a contributing factor which led to overdischarging the Horizon batteries and resulted in shorter than desirable lifecycle.

Out of Calibration SOC Gauge Readings - The SOC gauges were tested at various times during the project to determine accuracy. Since accuracy is dependent upon knowing the

capacity of the lowest or limiting module, the gauge was only accurate soon after a calibration. When there was a gradual decline in capacity and the calibration was not performed in a timely manner, the gauge became inaccurate and the readout misleading. The Horizon battery test vehicles required frequent recalibration. The time consuming calibration process was not performed frequently enough for the users to gain confidence in the Badicheq gauge. This was exacerbated by the fact that the Horizon battery had sufficient specific power to provide quick acceleration to the vehicle even if a battery or two were deeply discharged. Drivers began to ignore the gauge if they felt the gauge was reading erroneously.

Parasitic Losses - The Badicheq draws energy continuously from the main battery pack at a rate of 2.5 watts to operate its micro-processor. This is an insignificant amount relative to the size of most battery packs. The energy is easily replaced on the next charge cycle. It can cause a problem, however, if a vehicle is not driven for several weeks and if a vehicle is down for a couple of months awaiting repairs. The battery can become completely drained, yet the discharge rate is below the threshold that signals the Badicheq to activate the charger. This problem has been corrected by the new charging algorithm which provides an equalizing charge only on the second I phase of charging and activates the charger anytime a module drops below 2.25 volts per cell.

V. HORIZON BATTERY PACK RESULTS

The battery test project involved integration of Horizon batteries in seven test vehicles over the course of two years. There were five different vehicle types in the project so many challenging system integration tasks were performed. The Horizon battery also underwent several changes in the manufacturing processes as Electrosorce geared up for full-scale production. Following is a description of several types of data that was collected and analyzed:

- the number of cycles on battery packs
- the number of kwh into and out of the battery pack
- the number of kwh overdischarged below 80% DOD
- the number of kwh overcharged
- the discharge current frequency (driving style)

A. Analysis of Discharge Current Frequency - The Badicheq keeps track of the battery current during every discharge. This is a cumulative value in the Battery Statistics screen. The driving attitude frequency results are divided into eight sections. Results below are calculated from this data taken from Badicheq files on each of the vehicles. These numeric results are shown graphically below to illustrate the relative power use:

All AC Drivetrain Lightweight Vehicles - Driving Attitude Table					
Current Range (amps)	Horlacher PU-I E-037	Horlacher PU-II E-038	Horlacher Sport E-036	Solectria Force M-01	Average
145 -165	1.83%	1.55%	0.97%	0.94%	1.32%
125-144	1.17%	1.44%	1.07%	1.75%	1.36%
103-124	1.72%	3.78%	2.90%	3.85%	3.06%
83-102	3.13%	6.95%	3.61%	6.77%	5.12%
62-82	6.84%	7.46%	8.06%	7.64%	7.50%
42-61	11.58%	10.46%	15.76%	10.86%	12.17%
20-41	73.73%	68.37%	67.64%	68.18%	69.48%
Total	1.00	1.00	1.00	1.00	1.00

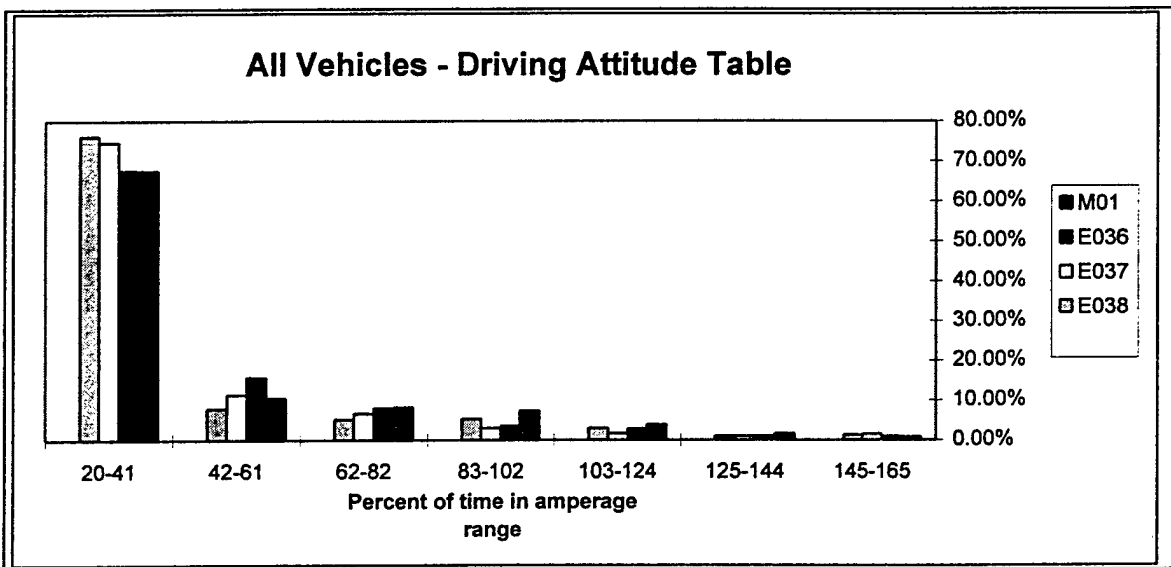

The G-Van is a special case. Because it has a 200 amp shunt, the "I" values are doubled. To the right are the calculated Driving Frequency results for G-Van #686 with its corresponding graphic chart below:

G-Van #686 - Driving Attitude		
Current Range (amps)	Current Duty Cycle	Average Current (amps)
290-330	0%	310.00
250-287	1.34%	268.33
207-247	7.86%	226.67
167-203	12.65%	185.00
123-163	17.00%	143.33
83-120	13.44%	101.67
40-80	47.72%	60.00

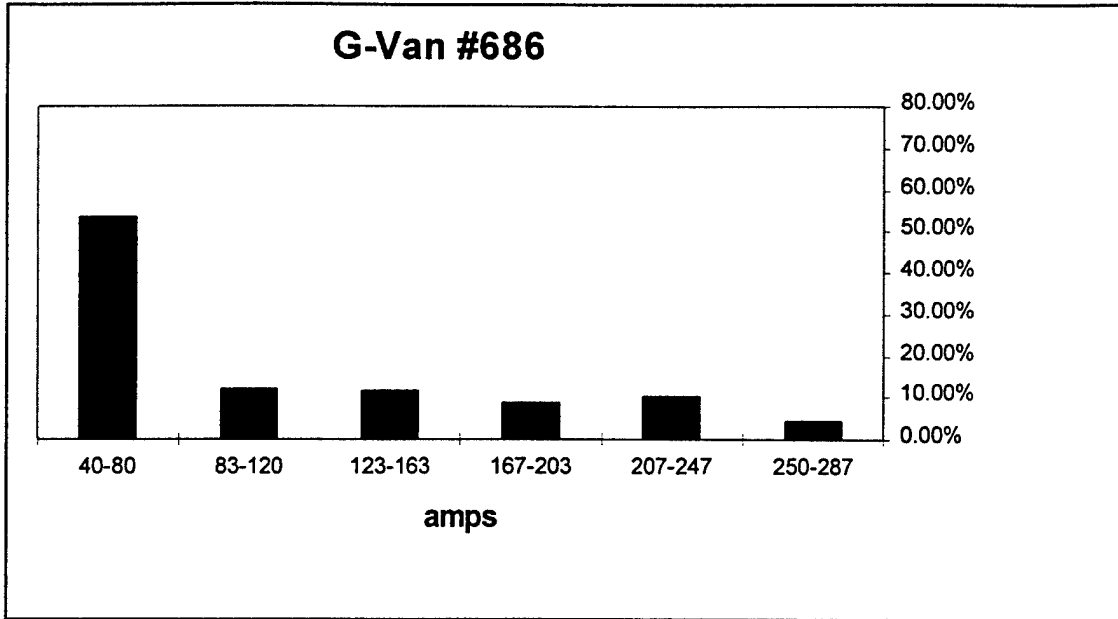

It is evident that the three lightweight composite vehicles and the lightweight Solectria Force coupled with efficient AC drivetrains provided very low demand on the batteries (average of 70% of the discharge time was under 40 amps). For comparison, we find the 8000 pound DC drivetrain G-Van experienced double the current demand (54% between 40 and 80 amps) and much higher peak demands (up to 287 amps).

B. Overcharge and Overdischarge - The cumulative amount of overcharge and overdischarge is tallied on the Battery Statistics screen ("s" screen) of each Badicheq file. The results for the field test vehicles are in the table below:

	Solectria Force	Horlacher P-I	Horlacher P-II	Horlacher Sport	G-Vans #685
Total cycles	396	456	364	193	209
# 100% discharges	36	19	14	28	13
# >80% discharges	77	59	43	57	17
total >80% + 100%	113	78	57	85	30
% over 80%+100%	57%	34%	31%	88%	29%
% overdischarge	1.9	1.12	0.63	1.94	.45

The high number of cycles experiencing overdischarge are a result of two situations mentioned earlier in this report:

- The calibration process which is so necessary to the proper functioning of the SOC gauge was time consuming and did not occur as often as needed for the changing state of the batteries.
- Misinformation in the beginning of the project about what constituted 80% DOD lead us to believe that 80% DOD was between 1.75 and 1.85 volts per cell (10.5 to 11 volts per module). In actuality, this represents 95% to 100% DOD. The repeated deep discharges

affected the life and subsequent capacity of the battery. Our understanding now is that in a dynamic driving cycle, 80% DOD falls between 1.916 to 1.933 volts per cell (11.5 to 11.6 volts per module) when read at open circuit voltage.

C. Energy Efficiency - The cumulative amount of DC energy "in" and DC energy "out" is saved on the Battery Statistics screen. Energy efficiency results from calculating in/out are listed in the table below. It is apparent from this table that the old Version A EPROM is not operating quite as efficiently as the others.

Also shown are the results of the overcharges derived from the Battery Statistics for the Horizon vehicles. The high percentage of overcharges may have impacted battery life, though the % overcharge is relatively low. There is a very consistent percentage of overcharges relative to the number of cycles. The significance of this number warrants equal scrutiny.

Vehicle	Solectria Force	Horlacher P-I	Horlacher P-II	Horlacher Sport	G-Vans (686)
Total # of cycles*	396	456	364	193	359
Total # charge cycles	198	228	182	97	180
# of overcharges	109	127	102	50	50
% of overcharges	55%	56%	56%	52%	28%
% overcharge	1.85	2.6	1.53	1.21	.9
Charge efficiency	74%	72%	79%	80%	88%
Present charge profile EPROM	A-2	A	A-2	A-2	special

*Badicheq cycles, which are only one way, charge or discharge

VI. CONCLUSIONS

Conclusions on the use of the Badicheq system in this project are as follows:

1. Overall, the Badicheq Battery Management System and Mentzer charger combination proved to be very robust. We experienced no failures of the Badicheq components themselves.
2. The use of the Badicheq prevented battery damage due to excessive overcharge and the equalization feature helped in maintaining pack charge balance.
3. Misunderstandings regarding 80% depth of discharge (DOD) determination caused a high number of deep discharges, which likely reduced battery life.
4. Frequent and high quality calibration of the State of Charge (SOC) metering function is necessary if the battery pack will be routinely discharged near 80% DOD. This improves data accuracy (and the resulting diagnostics), and reduces the risk of overdischarge.
5. Proper integration of new chargers and charge algorithms was a time consuming but necessary operation to assure that the charging system was working together and under control of the Badicheq.
6. The Badicheq output screens contain highly valuable information for pack diagnostics, however significant training and experience is needed to use them effectively.

APPENDIX J

HORIZON BATTERY INSTALLATION CONSIDERATIONS

Sacramento Municipal Utility District

March 1995

HORIZON BATTERY INSTALLATION CONSIDERATIONS

SACRAMENTO MUNICIPAL UTILITY DISTRICT - MARCH, 1995

The Horizon battery Project has provided a significant amount of installation related information. This brief summation of certain installation requirements, recommendations and considerations are intended to reflect critical and advisable steps to be taken for installation of Horizon batteries.

As more experience is gained with these and other sealed traction batteries, these considerations will be updated. The following summarizes findings thus far:

Connectors and Cables: The Electrosource Horizon 12N95 Model (12 volt-95 Amp-hr) was designed with terminal posts to fit Radsok 90° 10.3mm connectors, sized for 2/0 power cable (KonneKtech P/N 103-0004-2X). These connectors can be purchased from KonneKtech at (810) 294-7400. For a series battery pack, one connector is required for each terminal.

The recommended crimping tool is a Safe-mate crimper, Model No. 94283 or 94285. Sources for this tool can be found by contacting Mauldin Industrial Park at (803) 967-2615. Attached are a drawing and brief set of crimping instructions from KonneKtech (Attachment A). Connectors can be ordered factory crimped, and with insulating boots.

Connectors are also available from KonneKtech for use in series/parallel packs and parallel packs. The double end connector for use in these packs is a 180° 10.3mm Radsok connector for 2/0 cable, P/N 103-0041-2X. Additional information on parallel pack installations is included in the following section. Prior to any crimping, battery management system connections to terminals must be considered, as the battery management system leads can be crimped with the main power leads in the same connector barrel, or data tabs can be attached to the connector barrel.

The current recommendation of Electrosource is to use only connector cables that have a curve of approximately 1/2 inch fabricated into the cable prior to crimping. This is to minimize the side load on terminal posts. To minimize other loads, the cables should be fabricated using a fixture to position the connectors as they will be used in the pack.

Parallel Packs: One pack configuration that is currently being recommended is a series/parallel arrangement. One variation on this arrangement is shown in Attachment B. This example shows one half (one side) of a G-Van battery pack. Approximately half of the terminal connectors must be the 180° double end connector noted above. This arrangement appears to require the least power cable for a series/parallel pack.

A simple parallel arrangement is not now recommended by Electrosource. However, there may be advantages to the simple parallel pack in battery charge management. In the series/parallel arrangement, the preferential charging of individual modules will be less accurate. This issue is under review.

Battery Containment: Battery enclosures are advised for firm positioning of batteries. A side benefit is maintaining cleanliness of terminals and other areas of the pack.

Due to the need to allow for curved battery connector cables, the enclosures must be larger than the general outside dimensions of the battery modules would indicate. Allowance for approximately one inch of clearance from the end of the modules to the enclosure sides is advised.

Spacing of battery modules for ease of assembly and removal must be considered. Air circulation is accommodated more easily with gaps between modules, however, each module must be secure to prevent shifting during use.

A flat surface is recommended by Horizon for the surface on which the modules will rest.

Battery management systems, such as the Badicheq discussed below, can be installed in the battery enclosure if adequate space is provided or in an adjacent enclosure. A weather resistant enclosure is needed should the battery management module(s) not be weather resistant by design.

Multiple Layer Battery Packs: Horizon batteries may be layered provided certain considerations are taken during design and assembly of the pack. If the upper layer is not supported by a support framework or other means to physically support the second layer above the bottom layer, spacer strips between the layers may be used at 6 inch intervals along the length of the modules. The strips are positioned crosswise to the major dimension of the batteries. The spacing between layers is necessary for air flow. The spacing between support strips is necessary to spread the load of the top layer or battery modules.

Thermal Management & Ventilation: For minimization of thermal gradients and to prevent any hydrogen gas from remaining in the battery enclosure, ventilation of the battery enclosure is recommended. No gassing from valve regulated lead acid batteries will normally occur, but there is a potential for release of small amounts. A fan capable of one air change every ten minutes should be adequate.

A thermal management system that maintains battery temperature in its optimum range will enhance range and increase battery life. SMUD is testing a simple thermostatically controlled heating pads in one vehicle. SMUD does not have full thermal management systems planned for the current ARPA project, but may incorporate testing of such a system should one become available that can reasonably be incorporated into SMUD's program.

Battery Management System: The Badicheq battery charge management system is currently the only system recommended for Horizon batteries. Other systems are to become available soon that should also provide charge control and monitoring equivalent to the Badicheq. The Badicheq can be obtained through Drake Associates at (516) 666-1354.

The Badicheq does the following:

- monitors individual module voltage on discharge
- provides a low battery warning to the driver
- provides a preferential equalizing charge to selected modules
- monitors individual module voltage during charge
- controls the charger to prevent overcharge of any module

The equalizing function of the system improves the available capacity of the pack to increase range. The Badicheq is capable of adding one amp charge current to four modules at the beginning of the charge cycle. The overcharge control prevents life reduction of the pack due to thermal damage during excessive charging. The low battery alarm is set at 10.2 volts for the Horizon 12N95 battery, which helps prevent damage due to deep discharge.

The Badicheq measures 8 inches by 10 inches by 3 inches. This volume must be provided in the battery enclosure or other area.

Electrosources recommends placing a 2 amp fuse on each 18 gauge Badicheq lead close to the battery terminal connectors. Fusing of battery strings is also recommended. The National Electric Code and SAE EV safety codes should be consulted for guidance on safety of high voltage battery strings.

Charging Recommendations: The recommended initial charging current of 12N95 batteries is 38 amperes. A multistep charge profile is recommended that reduces the current by one half when all modules have reached 14.25 volts with no modules over 15.5 volts. Each subsequent step down in current is half the previous phase. The finishing/maintenance charge level is one amp.

If a multistep charge system is not available, a constant current/constant voltage/constant current charge profile is recommended. The initial charge current should be 38 volts for the 12N95 Model. For use with Badicheq or other charge management systems, the charger must be compatible with Badicheq signals for reduction of charge current when any module reaches the temperature compensated clamp voltage of 14.25 volts. Switched-mode, pulse width modulated chargers typically are compatible with the Badicheq.

One option being considered by SMUD is charging of discrete segments of a pack to reduce the charger power required to available power levels. Additional power cable is necessary for this method.

Table 1 lists the charger suppliers currently thought to supply Badicheq-compatible chargers. The Norvik charger is included, although Norvik's own charge management system is used.

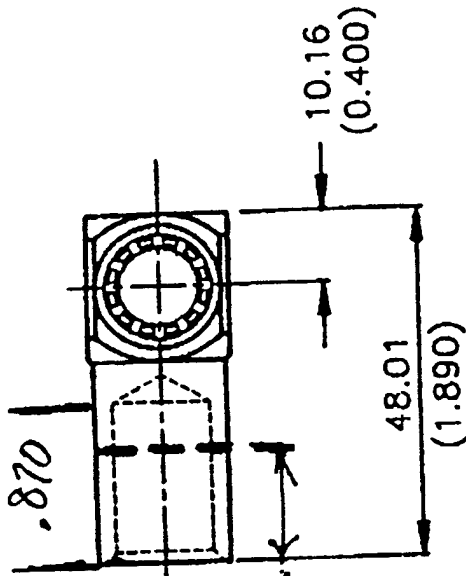

WIRE BARREL CRIMP AREA 5/8" WIDE

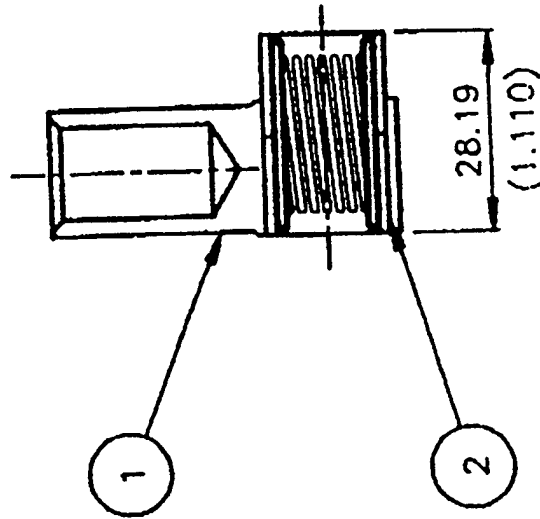
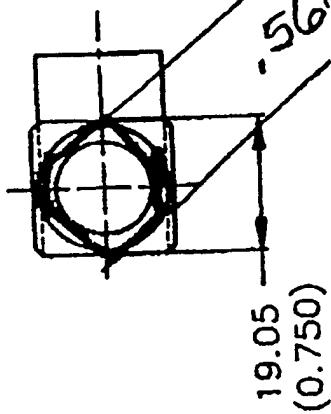

J-5

TOLERANCES EXCEPT AS SHOWN		SCALE FULL		DIMENSIONS METRIC		DRAWN BY: DJE	
METRIC (0.X) ± 0.25 (0.XX) ± 0.13 (INCH) (0.1XX) ± 0.010 (0.1XX) ± 0.005		DATE 11/10/93		APPROVED BY:			
ANGULAR ± 5		TITLE 10.3 MM RADSOK® CONNECTOR WITH 90° BARREL CRIMP HOLDER		MATERIAL FINISH		SEE DETAILS	
DRAWING NUMBER 103-0004-2X		PART NUMBER 103-5003-2X		SHEET 1 of 2		REV. D	

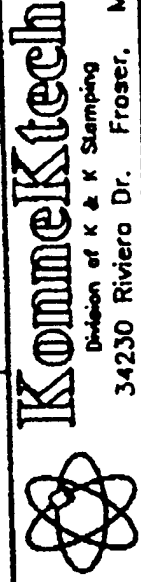

DETAIL	PART NUMBER
1	103-5003-2X
2	103-001

PART NUMBER



KONNEKTECH

DIVISION OF K & K STAMPING COMPANY

34230 Riviera Drive • Fraser, Michigan 48026 • U.S.A.

(810) 294-7400 • (810) 294-7402 FAX

FAX TRANSMITTAL COVER SHEET

DATE <i>12-28-94</i>	NUMBER OF PAGES <i>2</i> <small>(INCLUDING THIS SHEET)</small>
ATTENTION <i>RUTH</i>	COMPANY <i>SMUD</i>
FROM <i>JULIE TRUDEAU</i>	PLEASE <input type="checkbox"/> PHONE RESPOND <input type="checkbox"/> FAX RESPOND

MESSAGE:

RUTH:

REGARDING CRIMP ON BRASS HOLDER

- 1) DEPTH OF WIRE HOLE IS .870" DEEP - STAY BACK TOWARDS THE END DO NOT EXCEED 5/8" WIDE CRIMP*
- 2) USE .500" (ACROSS FLATS) HEX CRIMP TO AVOID OVER CRIMPING*
- 3) YOUR CRIMP SYSTEM SHOULD BE ACCEPTABLE JUST BE CERTAIN THE CRIMP ISN'T TOO CLOSE TO THE MAIN CONNECTOR BODY HOLDING THE RADSOX CONTACT*

Julie

FAX TO: <i>916-732-6839</i>	CONTACT US AT (810) 294-7400
--------------------------------	------------------------------

Note to Facsimile Operator: Please deliver this facsimile transmission to the above addressee(s). If you do not receive all of the pages in good condition, please advise the sender at your earliest convenience. Thank you.

TABLE 1

<u>Vendor</u>	<u>Status</u>
Mentzer Charger Drake Associates (516) 666-1354 57 Park Ave Bayshore, NY 11706	Designed for the Badicheq. Maximum charge current for 3 kw charger is 11 amps, for 6 kw it is 22 amps.
Martin Marietta Charger Ulysses Camillo (607) 770-3063 600 Main Street Johnson City, NY 13798-1888	10 kW charger Available after January of 1995 Can interface with Badicheq.
George Bellino (310) 517-6001 Hughes Power Control Systems PO Box 2923 Torrance, CA 90509-2923	Off board inductive charger can acheive 20 amps. Can interface with Badicheq.
David Packard (404) 449-1104 EPTI Rapid Charging System 6400 Atlantic Blvd, Ste 130 Norcross, GA 30071	6.6 kW Pulse charging system. Working on interface with Badicheq.
Sandi Salvhus (303) 484-3080 Good-all Electric 3725 Canal Drive Fort Collins, CO 80524	Only off board chargers available. Can interface with Badicheq.
K & W Charger BC 250 Ken Koch (909) 949-7914 KTA Services 12531 Breezy Way Orange, CA 92669	Interface is possible with Badicheq.
Zivan Onboard Charger Gary Flo (707) 964-1331 MendoMotive 30151 Navarro Ridge Road Albion, CA 95410	Interface is possible with Badicheq. Provides 15 amps to 144v pack with 240 volt 50amp plug.
Curtis Pearson (410) 993-2697 Westinghouse Electric Co. PO Box 746, MS B420 Baltimore, MD 21203	
Janet Vogt (905) 828-7700 Norvik Charger 2480 Dunwin Drive Mississauga, Ontario Canada L5L 1J9	Smart charger of 24kW or 33 kW size can be paired with BEMS system for best charge management.