

X-17416

UNCLASSIFIED

AECD-3885

Subject Category: CHEMISTRY

UNITED STATES ATOMIC ENERGY COMMISSION

LABORATORY UNITS FOR DISSOLVING, HEAD-END TREATMENT, AND SOLVENT EXTRACTION

By
J. R. Gould

19970311 131

October 3, 1952

Knolls Atomic Power Laboratory
Schenectady, New York

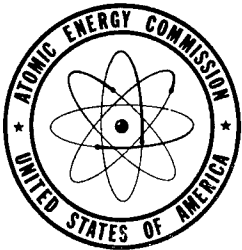

Technical Information Service, Oak Ridge, Tennessee

DISTRIBUTION STATEMENT A
Approved for public release;
Distribution Unlimited

UNCLASSIFIED

DTIC QUALITY INSPECTED 1

Date Declassified: January 6, 1956.

This report was prepared as a scientific account of Government-sponsored work. Neither the United States, nor the Commission, nor any person acting on behalf of the Commission makes any warranty or representation, express or implied, with respect to the accuracy, completeness, or usefulness of the information contained in this report, or that the use of any information, apparatus, method, or process disclosed in this report may not infringe privately owned rights. The Commission assumes no liability with respect to the use of, or from damages resulting from the use of, any information, apparatus, method, or process disclosed in this report.

This report has been reproduced directly from the best available copy.

Issuance of this document does not constitute authority for declassification of classified material of the same or similar content and title by the same authors.

Printed in USA, Price 20 cents. Available from the Office of Technical Services, Department of Commerce, Washington 25, D. C.

AECD-3885

General Electric Company
KNOLLS ATOMIC POWER LABORATORY
Schenectady, New York

LABORATORY UNITS FOR DISSOLVING, HEAD-END TREATMENT,
AND SOLVENT EXTRACTION

J. R. Gould

October 3, 1952

Operated for the
United States Atomic Energy Commission
by the
General Electric Company
Contract No. W-31-109 Eng-52

AECD-3885

CONTENTS

	<u>Page</u>
Acknowledgement	5
Abstract	5
I. Introduction	6
II. Cell Structure	6
III. Slug Dissolving	7
IV. Head-End	12
V. Sampling of Process Streams	12
VI. Waste Disposal	13
VII. Batch Countercurrent Extraction Unit	13
VIII. Design Aspects	15
IX. Unit Services	16
X. Health Physics	16

ACKNOWLEDGEMENT

The author desires to express his thanks to J. V. Bechard, J. W. Coddling, J. L. Lawler, T. M. Shepherd, and D. J. Smith for their helpful contributions in the development of the unit.

ABSTRACT

This report describes a laboratory-scale unit equipped to dissolve Hanford slugs, head-end treat, and solvent extract the feeds. These facilities are very useful for the testing and development of a variety of processes with a minimum expenditure of time, manpower, and money. With equipment of this type, complete process information may be obtained on a 300 ml scale at full activity level.

LABORATORY UNITS FOR DISSOLVING, HEAD-END TREATMENT,
AND SOLVENT EXTRACTION

J. R. Gould

I. INTRODUCTION

A laboratory-scale facility consisting of a one-slug dissolver, head-end apparatus, and a solvent extraction unit was designed to study head-end process variables and solvent extraction flow sheets. Experimentation to date has been largely devoted to the treatment of dissolved metal prior to solvent extraction, that is, head-end processing, in order to minimize the number of extraction cycles necessary to meet uranium and plutonium decontamination specifications. Liquid-liquid solvent extraction studies have been associated with flow sheet variations and related problems.

II. CELL STRUCTURE

A concrete cell which is partitioned by two steel panels into three chambers houses the apparatus (Figure K-6A3834). The first chamber contains a dissolver, storage vessel, and off-gas scrubber; the second, a make-up vessel, waste tank, and a filter; and the third, a fifteen-stage batch countercurrent contactor with feed and end-stream tanks. The cell dimensions are given in Figure K-6A3834 while the capacities and relative locations of the various units in the cell are shown in Figure TH-9A9505.

A steel door, the height of the cell, provides entry into an access corridor running the length of the cell. From this corridor are operated 1-inch lead doors, not shown in Figure K-6A3834, which enclose the cell blocks. These doors provide radiation protection for personnel entering the access corridor.

The top of the cell is enclosed by a plexiglas hood. This hood and the use of mirrors permit remote inspection of operations in any portion of the cell. Located in the hood are damper-controlled air intakes equipped with filters which control the flow of air to the cell. The exhaust duct is extended to the floor level of the access corridor (Figure K-6A3834) to effect a downdraft circulation of air. Pressure in the cell is maintained below that of the room in order to isolate air-borne contamination. The air change rate in the cell is 40 times per hour. Fluorescent lights, located above the hood, illuminate the cell.

Shielding was designed on the basis of 2 curies of activity in the stages of the contactor. The stages were selected as the basis for shielding calculations, since the necessity of visually inspecting stage operation prohibited the shielding of each stage. All other sources of feed in excess of 2 curies were independently shielded. Concrete was selected as the

shielding material, and the cell walls were made 2 feet thick in order to limit the radiation at the exterior surface to 1 mr/hr.

In addition to the indirect method of inspecting operations by means of mirrors, direct observation is obtained by viewing windows designed for zinc bromide solutions. The shielding provided by these baths is equivalent to 2 feet of concrete. Water, in place of zinc bromide, has been used to date as the shielding medium since 90% of the gamma radiation is removed by head-ending the feeds used in separations studies. The size (4 feet x 2 feet x 2 feet) of the inspection window in the contactor cell is sufficiently large to enable viewing all stage and stage-sampling operations. A four-power telescope is used to improve the accuracy in reading the interface for phase separation in liquid-liquid extractions. Other readings in the unit, such as liquid level in the condensate receiver, are observed by means of similar baths made of 1 1/2-inch diameter sleeves through the cell wall.

III. SLUG DISSOLVING

Slugs are transferred from SPRU slug carriers to a one-slug carrier adapted for the unit. The unit carrier, as shown on Plate 1111433, is then elevated above the cell by a crane and positioned over the dissolver by a monorail. The carrier is lowered, guided by a carrier chute, to a retractable plate on which the carrier plug is deposited. The slug is then released after lowering the carrier to the dissolver chute. These operations are conducted remotely by means of reach rods inserted through ports in the cell wall (Figure KH-9A2164) and used to disengage the carrier pins holding the slug and carrier plug in place.

Normally, one quarter of the slug is dissolved, and the dissolved metal solution is transferred to storage for batch processing. All active solution transfers are effected by reducing the pressure in the receiving vessel. This method is used in order to eliminate dilution of the feed that would be encountered by jet transfers and to minimize the chances of displacing feed from the system which would be possible when using pressure as a means of transfer. Thermal agitation of the feed has proved satisfactory in past operations; however, additional agitation may be obtained, when warranted, by sparging through nitrogen dip legs.

Thermocouples in the vessels and jackets, in conjunction with controlled steam pressure and/or water rate to the vessel jacket, provide temperature control to within $\pm 2^{\circ}\text{C}$. A bubbler manometer system is used to measure the specific gravity and liquid level of the feed in the dissolver and head-end process vessels (Figure TH-9A9505).

During feed processing, the vessel pressure is maintained at 1 to 2 inches of water below atmospheric by an air jet. The jet capacity is controlled to effect a very slight air sweep of the vessel observable in a pressure indicator

- 1. CONCRETE SHIELD
- 2. PLEXIGLASS HOOD
- 3. VENT DUCT
- 4. CONTROLLED VENT
- 5. 4" STEEL DOOR
- 6. SAMPLE EXIT
- 7. CELL NO. 1
- 8. CELL NO. 2
- 9. CELL NO. 3
- 10. INSPECTION WINDOW
- 11. SAMPLE CART DRIVE
- 12. SAMPLE CART

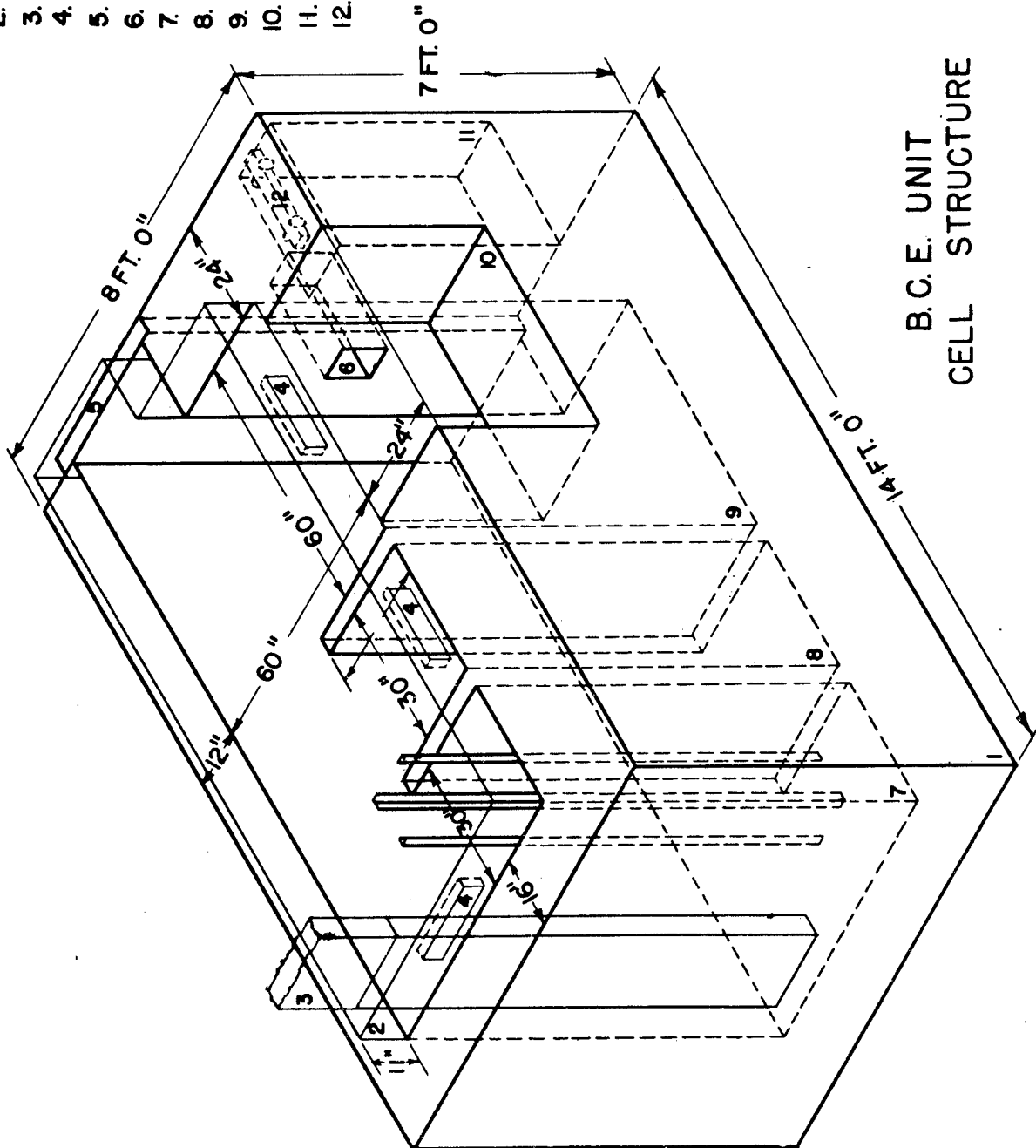

B.C.E. UNIT
CELL STRUCTURE

K-6A3834

- S.L. SAMPLE LINE
- P.I. PRESSURE INDICATOR
- C.E. CHEMICAL ENTRY
- C.O. COLD WATER
- H.W. HOT WATER
- N₂ SPRAY NITROGEN PRESSURE
- ST. STEAM
- V_g VACUUM
- Hot Valve Being Shield
- Cold Valve Being Shield

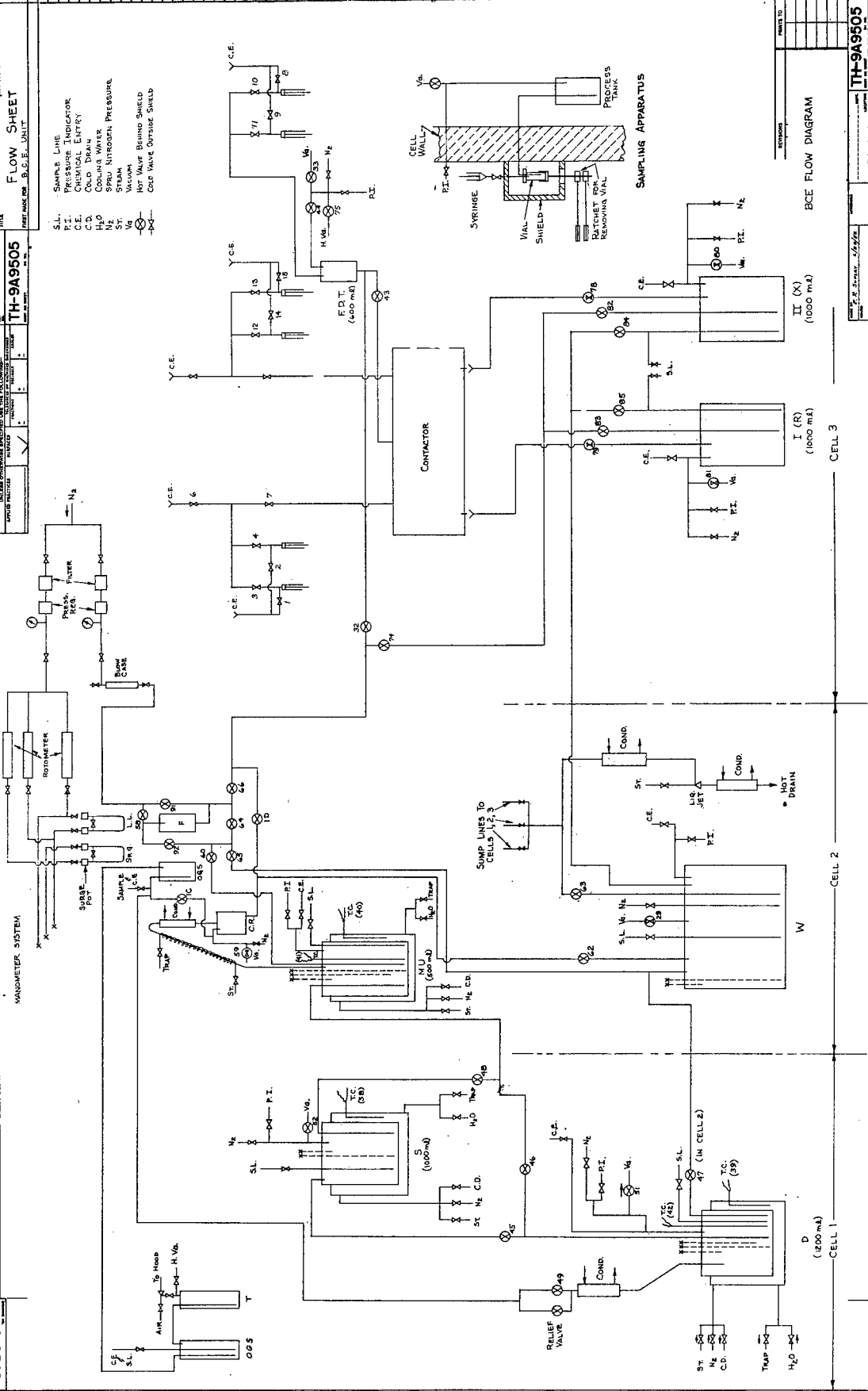

BCE FLOW DIAGRAM

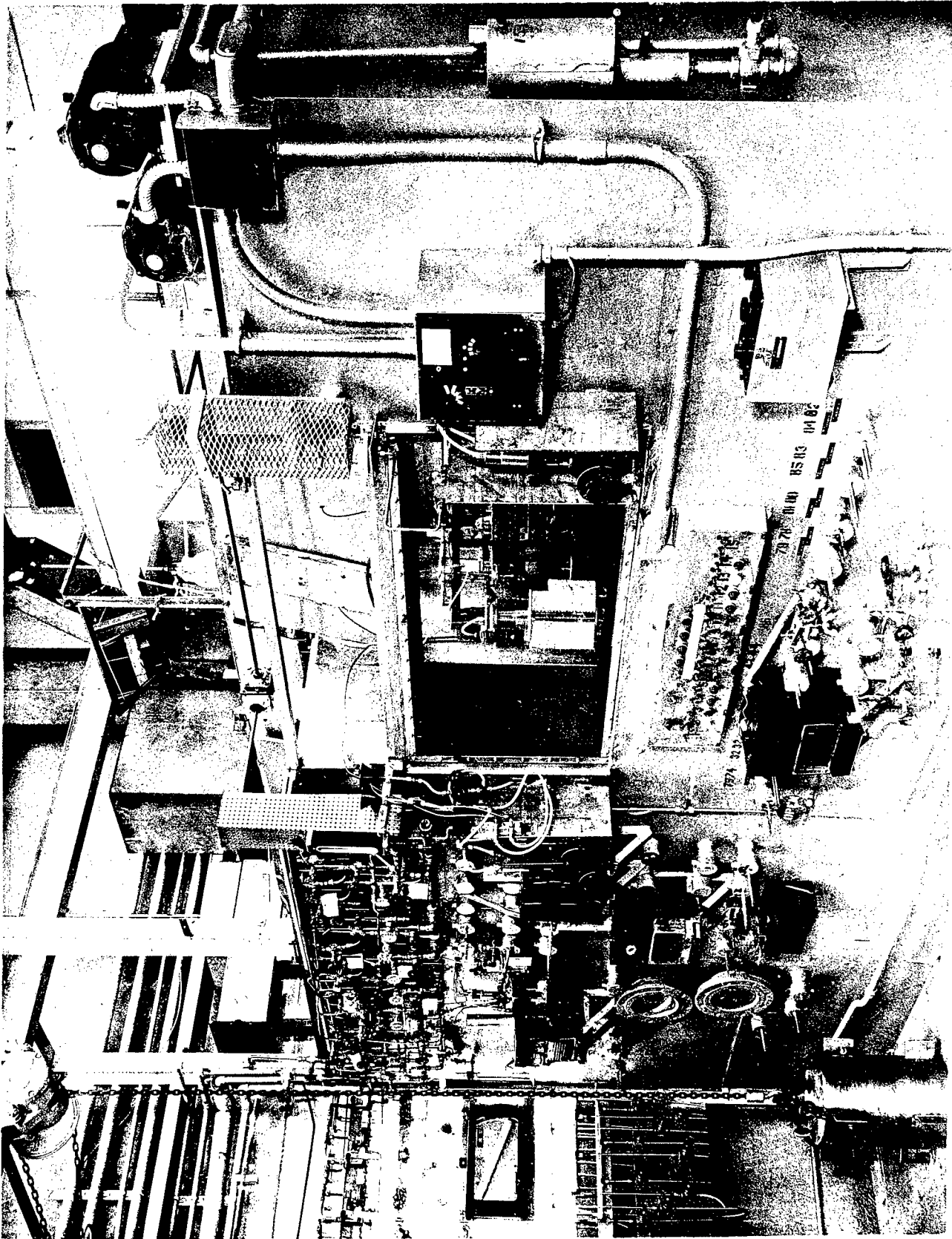

1111433 Photograph of Cell

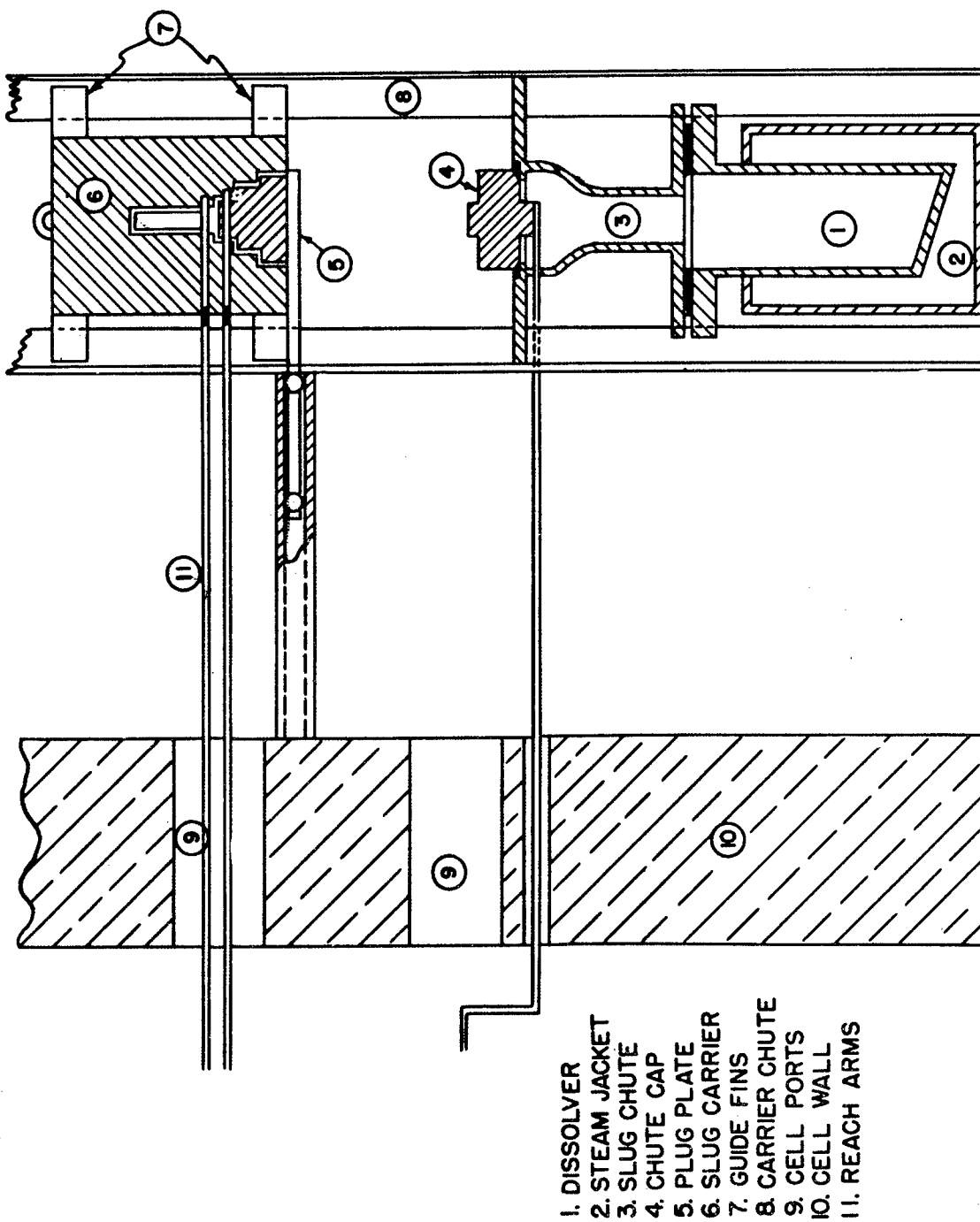

DISSOLVER CELL

KH-9A2164

located at the cell exterior. The radioactive gases volatilized from solution are scrubbed with caustic prior to entering the cell exhaust duct. Glass wool and CWS filters located in the exhaust duct retain any particulate matter leaving the system.

IV. HEAD-END

Head-end treatment of the dissolved metal consists of the oxidation and volatilization of ruthenium, the scavenging of zirconium and niobium, clarification of the feed, adjustment of the feed to meet flow sheet specifications, and plutonium valence stabilization. In place of a centrifuge, a stainless steel porous filter, with a filter aid, has been used in the laboratory to clarify the feed.

Treatment of the feed takes place in the make-up vessel located in the second cell. This vessel is equipped with a refluxing condenser and a condensate receiver for the purpose of concentrating feeds to meet flow sheet specifications. Feed clarification, prior to transfer of feed from the make-up vessel to Cell 3, is accomplished by a "porosity H" (5 micron), Micro-Metallic filter. The filter is positioned in a glass pipe case in order to observe the effectiveness of filtering operations. In conjunction with the filter, a sight glass is used as a blow case in order to control purging of the system with either gases or liquids under pressure.

V. SAMPLING OF PROCESS STREAMS

Samples of the feed are transferred from the process tanks by means of syringes to shielded vials located at the cell exterior. Two dip legs enter the vial. The longer dip leg originates in the vessel and extends into the vial to a predetermined depth which regulates the sample size. The shorter dip leg is attached to the syringe and functions to eliminate overflow of the vial. A double ratcheting arrangement is used to remove and replace the vials which are coupled to the system by ferrule and nut fittings. Lead glass viewing windows, which are noted in connection with the lead boxes masked in black on Plate 1111433, are used to observe manipulations in the sample ports. Calibrated displacement of the syringe plunger and monitoring of the sample port are the techniques used to determine the presence of sample in the vial. Chemicals may be charged to the process vessels through the sample lines as well as through the lines installed for this purpose. A schematic arrangement of the sampling apparatus is shown on Figure TH-9A9505.

Valve stem extensions, housed in sleeves through the cell wall, enable flow control from the cell exterior. For the most part, Cooper-Alloy blunt needle valves are used in both the hot and semihot areas. Extended leak-free service has been obtained from these valves by using shredded teflon and neoprene washers as packing material -- the neoprene supplying the needed resilience, lacking in teflon, to extend the life of the packing without packing-gland adjustment.

The process vessels and flow lines are constructed of Type 347 stainless steel, with the exception of the condensate receiver, filter case, and feed displacement tank which are made of pyrex glass pipe. The use of glass in the system has been minimized to avoid the attendant problems resulting from breakage; however, the direct viewing of calibrated glass vessels has proved to be an excellent method of checking feed volumes metered by bubbler manometers.

VI. WASTE DISPOSAL

Disposal of waste materials is effected by collecting these solutions in the waste tank, diluting to allowable activity levels, and jetting to (waste recovery). The bottom of each cell chamber contains a catch basin (sump) 4 inches high, covering the floor surface. These basins, when contaminated from spills and/or leaks in the system, may be flushed with decontaminating solutions which are collected in the waste tank by sump lines to each basin. The cell walls, inside and out, the cell floor, and the operating floor have been strip-coated to prevent corrosion on nonstainless surfaces and to provide a surface which, if contaminated, could be conveniently removed and restripped.

VII. BATCH COUNTERCURRENT EXTRACTION UNIT

A positive displacement system is used for feeding both active and inactive feeds to the bank. Displacement fluids, which are mutually insoluble with respect to the feed, are used to confine active feeds to the shielded zone. Conventional glass syringes, the plungers of which are positioned by turning a graduated dial, charge regulated volumes of feed to the stages.

The contactor consists of 15 stages: eight (odd-numbered) are mounted on a stationary plate, and the remaining seven (even-numbered) on a movable plate. The even stages operate in a vertical plane to positions above and below each odd adjacent stage. Countercurrent flow of phases is effected by collecting the lower phase from the odd stages to the left and the remaining phases from the even stages to the right -- alternate stages containing both phases prior to the mixing of phases.

Each stage has an operating capacity of 25 ml (Figure KH-9A1076). A magnetic coupling agitates the phases. The drive magnets are chain driven, and the speed is controlled by a variable speed motor. Theoretical efficiencies are obtained

at 700 rpm. Two fins attached to the slave magnet and the cycling of the phases through a "milled-out" section of the stem, as shown in section "A-A", improve the mixing characteristics of the stage. Both the drive and slave magnets are encased in stainless steel to prevent corrosion.

Feed is charged to the stages through a funnel to which a valve stem is coupled. The stainless steel stem is ground into a conical glass seat and is held in place by spring tension to prevent leakage. A lever actuated by a solenoid opens the valve. On, off, and momentary toggle switches mounted

**B. C. E. UNIT
(CONTACTOR STAGE)**

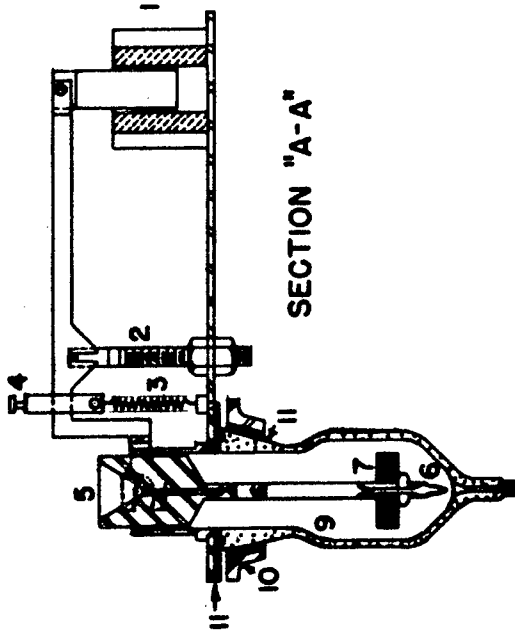
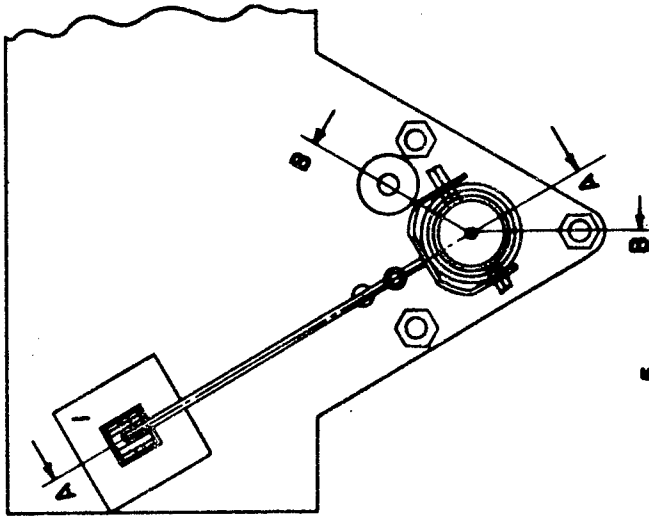

SECTION "A-A"

- 1 SOLENOID
- 2 PIVOT & ADJUSTMENT
- 3 TENSION SPRING
- 4 TENSION ADJUSTMENT
- 5 ENTRY FUNNEL
- 6 VALVE STEM

- 7 SLAVE MAGNET
- 8 DRIVE MAGNET
- 9 STAGE BODY (GLASS)
- 10 FLANGE
- 11 GASKET
- 12 PLATE

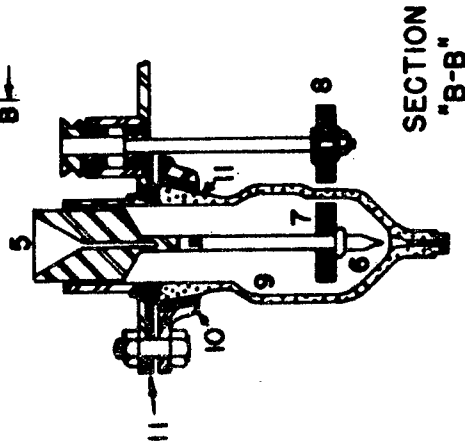

SECTION "B-B"

KH-9A1076

on the control panel enable continuous release or dropwise control of liquid transfers. End streams from the stages are transferred by funnels to end-stream tanks where they are held for continued processing or are discarded as waste.

Since each stage acts independently as a unit and stage holdup is less than 1% of operating capacity, back-mixing of phases will not significantly affect operation. The unit is also quite flexible because it can be conveniently arranged, within the 15-stage limitation, to simulate the various liquid-liquid extraction units used in the decontamination of uranium and plutonium streams.

Stage samples for equilibrium evaluations are taken by elevating vials, positioned on a sample carriage, to the stage tips. The vials are placed in the bottom half of vial shields prior to transferring the carriage into the contactor cell (Cell 3). As the carriage emerges from the cell, the top half of the shield is positioned over the vials to eliminate personnel exposure during sampling operations.

As may be observed on Plate 1111432, the even stages are positioned to receive liquid transfers from the odd stages to the left. The feed streams to the bank are attached to the stationary plate so that feed is charged to Stages 3, 7, and 13--the end stream funnels collecting from Stages 3 and 13. The arrangement indicated would be representative of an eleven-stage bank of five extraction and six scrub stages. The sample carriage is elevated above the transfer rail to receive samples from Stages 6, 8, 10, and 12. The vial adapters on the carriage are those used in relatively cold studies and are not to be construed as the bottom half of the vial shield previously discussed. Stage 15 is partially obscured by the spot lamp located on the right. The feed displacement tank, in which the head-ended feed is collected prior to extraction processing, is visible at the left of the plate.

The stage and sampling operations in the third cell are remotely controlled by switches on the control panel located below the inspection window (Plate 1111433). Position lights indicate the location of the stages and the sample carriage. Safety circuits prevent overtravel that would cause mechanical damage, and relay locking devices prevent resetting stage directional switches until the selected motion has been completed. The unit has been operated with but minor mechanical and electrical difficulties encountered on the start-up by using cam-actuated microswitches to energize the circuit relays. A schematic representation of the electrical system is shown in Figure KH-9A1077.

VIII. DESIGN ASPECTS

To expedite the completion of the unit, certain features of the initial design were not included in the construction. The process stream sampling system now in use is not to be recommended for high-level operations for the following reasons:

1. The radiation exposure received per sample is one-third the daily permissible limit.

2. The operations involved in transferring the vial from the sample port to the vial shield enhances the possibility of a spill.

3. The remote handling equipment used in the transfer is a source for the spread of contamination in the laboratory.

4. The system is very difficult to decontaminate.

A sampling unit is now being constructed which eliminates the first three difficulties because the sample may be removed from the unit completely shielded by remote handling equipment contained in the sample port. This unit may also be easily decontaminated since all points of suspected contamination may be conveniently flushed.

Although each chamber in the cell may be isolated to make repairs, extensive time is required to decontaminate a chamber. Ports through the cell wall which would provide convenient access to specific items in the cell, such as valves, would enable repairs without the time-consuming operation of decontaminating the entire chamber.

IX. UNIT SERVICES

Services available to the unit include high-pressure steam, nitrogen, air, and water; 440, 220, and 110-volt a-c electricity; 220 and 125-volt d-c electricity; off-gas, waste disposal, and liquid transfer vacuum systems.

X. HEALTH PHYSICS

Every effort is made to minimize the radiation exposure to personnel in the laboratory. Protective clothing is worn which is frequently monitored and discarded if found contaminated. In addition to pocket meters, film badges, and finger rings normally worn by personnel associated with activity, films are placed on the safety glasses worn on the head in order to better estimate over-all body exposure. Health Physics makes a daily survey of the laboratory prior to the start of operations in order to familiarize the operating personnel with the radiation zones and the time limits in these zones. Daily samples of the air are also taken and inspected for air-borne contamination. A continuously recording ionization chamber adapted to sound an alarm in the event radiation levels exceed room background is another protective measure taken. The close inspection of operations by the Health Physics Unit and the training of personnel in the handling of active materials has contributed largely to the prevention of any serious overexposures in the laboratory.

The results from the laboratory have been found to be in very good agreement with those from similar studies. The program and the results of studies made in the laboratory are discussed in detail in the KAPL Chemistry and Chemical Engineering Quarterly Reports.

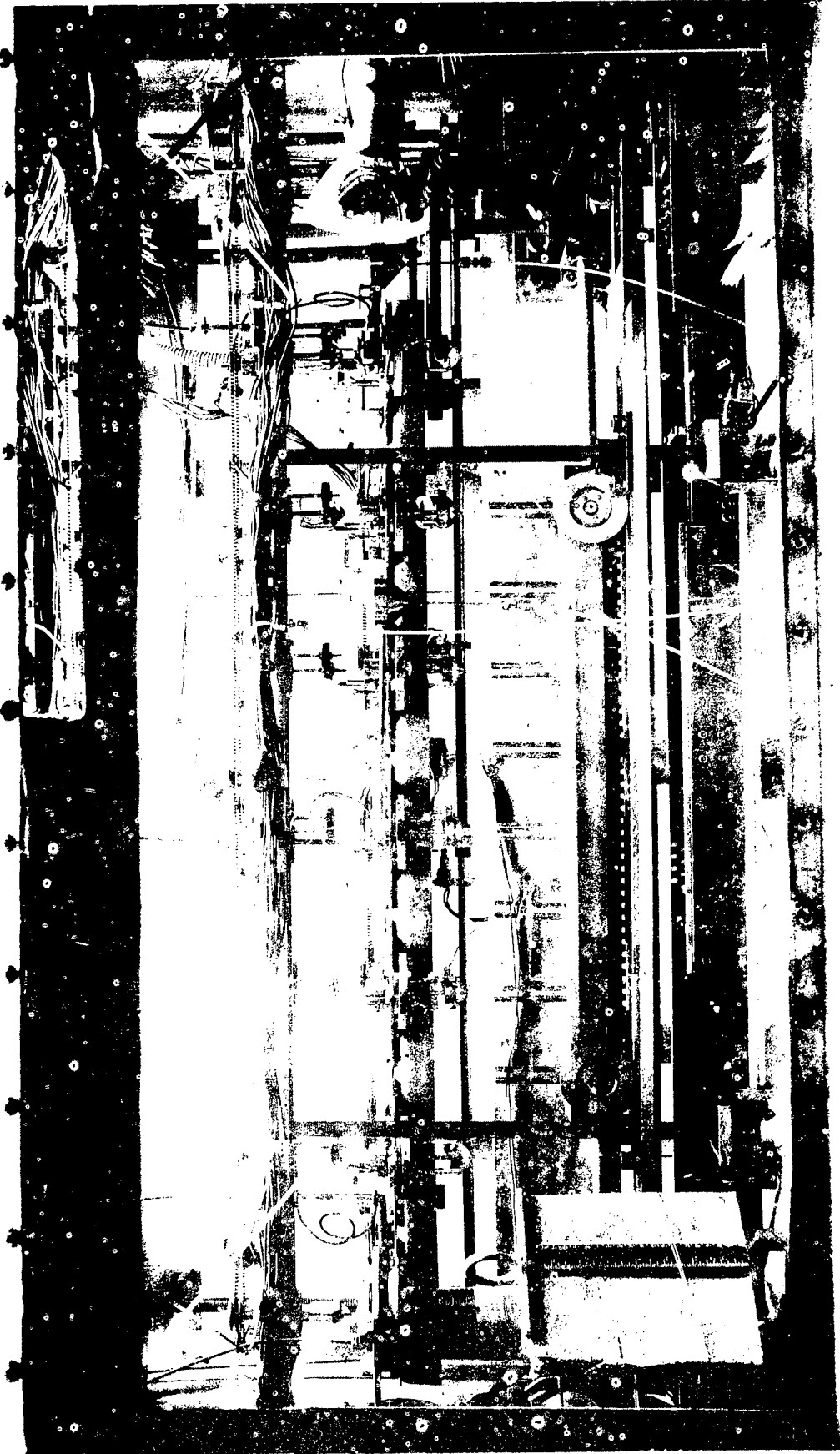

1111432 Photograph of Contactor

B.C.E. UNIT (ELECTRICAL DIAGRAM)

