

TARDEC

---TECHNICAL REPORT---

THE NATION'S LABORATORY FOR ADVANCED AUTOMOTIVE TECHNOLOGY

No. 13712



WINNER OF THE 1994 FEDERAL QUALITY IMPROVEMENT PROTOTYPE AWARD

M-2 BAILEY BRIDGE
COMPONENT INSPECTION PROCEDURES

March 1997

19970321 086

By Anh V. Nguyen

APPROVED FOR PUBLIC RELEASE:
DISTRIBUTION IS UNLIMITED

U.S. Army Tank-Automotive Research,
Development, and Engineering Center
Detroit Arsenal
Warren, Michigan 48397-5000

DTIC QUALITY INSPECTED 3



DEPARTMENT OF THE ARMY
UNITED STATES ARMY TANK-AUTOMOTIVE AND ARMAMENTS COMMAND
WARREN, MICHIGAN 48397-5000

REPLY TO
ATTENTION OF

March 17, 1997

At the conclusion of World War II, the US Army had as its dry gap support bridge, the M2 Bailey Bridge developed by the British Army. Most of the US Army Bailey assets were fabricated in the US from British drawings. At one time, the US Army had an inventory of approximately 5 miles of Bailey Bridge.

The current 3.5 miles of M2 Bailey Bridge is stored in Depots, Combat Engineering Groups, and other organizations. There are no Active Force Panel Bridge Engineering Companies.

The availability of the current stockpile of M2 Bailey Bridge for operational use was unknown. No procedures existed for the systematic inspection and classification of M2 Bailey Bridge Components. Many of the M2 Bailey Bridge sets have been in storage for extended periods of time.

With this in mind, the US Army Aviation-Troop Command and Tank-automotive & Armaments Command initiated a project to develop inspection procedures using the Federal Condition Codes.

This report documents the Inspection Procedures and their development. The procedures have been successfully used by the Sierra Army Depot and several Engineer Combat Equipment Companies in Europe.

Inspection and maintenance of the existing M2 Bailey Bridge assets are an important measure in insuring its availability for use by the Engineers in the future.

John D. Stanek
Support Bridge Team Leader

REPORT DOCUMENTATION PAGE

Form Approved
OMB No. 0704-0188

Public reporting burden for this collection of information is estimated to average 1 hour per response, including the time for reviewing instructions, searching existing data sources, gathering and maintaining the data needed, and completing and reviewing the collection of information. Send comments regarding this burden estimate or any other aspect of this collection of information, including suggestions for reducing this burden, to Washington Headquarters Services, Directorate for Information Operations and Reports, 1215 Jefferson Davis Highway, Suite 1204 Arlington, VA 22202-4302, and to the Office of Management and Budget, Paperwork Reduction Project (07040188), Washington, DC 20503.

1. AGENCY USE ONLY (Leave blank)		2. REPORT DATE 6-Mar-97	3. REPORT TYPE AND DATES COVERED FINAL	
4. TITLE AND SUBTITLE M-2 BAILEY BRIDGE COMPONENT INSPECTION PROCEDURES			5. FUNDING NUMBERS	
6. AUTHOR(S) ANH V. NGUYEN DSN 786-6291/COMM 810-574-6291 nguyenan@cc.tacom.army.mil				
7. PERFORMING ORGANIZATION NAME(S) AND ADDRESS(ES) US ARMY TANK-AUTOMOTIVE AND ARMAMENTS COMMAND SUPPORT BRIDGE TEAM AMSTA-TR-R/21 WARREN, MI 48397-5000			8. PERFORMING ORGANIZATION REPORT NUMBER 13712	
9. SPONSORING / MONITORING AGENCY NAME(S) AND ADDRESS(ES) US ARMY AVIATION -TROOP COMMAND WEAPON SYSTEMS MANAGEMENT - ENGINEERING EQUIPMENT AMSAT-D-WME 4001 GOODFELLOW DRIVE ST. LOUIS, MO 63120-1798			10. SPONSORING / MONITORING AGENCY REPORT NUMBER	
11. SUPPLEMENTARY NOTES This report is not to be construed as an official Department of the Army position. Destroy this report when no longer needed. Do not return to the originator.				
12a. DISTRIBUTION / AVAILABILITY STATEMENT Distribution A. Approved for public release; distribution is unlimited.			12b. DISTRIBUTION CODE	
13. ABSTRACT (Maximum 200 words) This report includes a manual of the M-2 Bailey Bridge (M2BB) Component Inspection Procedures which were developed from April 1996 to November 1996. The M2BB is an old system of the Army, and there were no inspection procedures available to classify their components using the Federal Condition Codes before this development. Early in FY96, the US Army Aviation-troop Command (ATCOM) tasked the Support Bridge Team (SBT), US Army Tank-Automotive Research, Development and Engineering Center (TARDEC) to develop inspection procedures to evaluate the Bailey Bridge assets. These procedures were developed to inspect all components of the M2BB basic set and classify them as serviceable with qualification or not. In July 1996, ATCOM requested SBT to update these procedures to include components of M2BB erection equipment set and conversion set and using the Federal Condition Codes B (serviceable with qualification), E (limited restored), F (unserviceable but repairable), G (unserviceable - incomplete), and H (unserviceable and condemned) in order to evaluate Bailey Bridge assets in Europe. During the progress of the development, the target audience of soldiers with MOS 12C was always kept in mind. In November 1996, the M-2 Bailey Bridge Component Inspection Procedures were finalized and put together as a manual.				
14. SUBJECT TERMS M-2 Bailey Bridge (M2BB), Condition Codes, Excessive Rust/Corrosion, Physical Damage, Cracked or Broken Welds.			15. NUMBER OF PAGES 58	
			16. PRICE CODE	
17. SECURITY CLASSIFICATION OF REPORT UNCLASSIFIED	18. SECURITY CLASSIFICATION OF THIS PAGE UNCLASSIFIED	19. SECURITY CLASSIFICATION OF ABSTRACT UNCLASSIFIED	20. LIMITATION OF ABSTRACT UL	

TABLE OF CONTENTS

1. INTRODUCTION 1

2. METHODS, ASSUMPTIONS, AND PROCEDURES 1

3. RESULT & DISCUSSION 4

4. CONCLUSION AND RECOMMENDATIONS 4

5. DISTRIBUTION LIST 5

6. ANNEX 1:
M-2 BAILEY BRIDGE COMPONENT INSPECTION PROCEDURES 6

1. INTRODUCTION

Currently, the United States has 142 M-2 Bailey Bridge (M2BB) basic sets, 65 M2BB erection equipment sets, 37 M2BB conversion sets, and 15 M2BB cable reinforcement sets but there were no inspection procedures available to classify the Bailey Bridge components using the Federal Condition Codes. For this reason, the Weapon Systems Management Directorate, US Army Aviation-Troop Command (ATCOM) requested the Support Bridge Team (SBT), US Army Tank-Automotive Research, Development and Engineering Center (TARDEC) to develop inspection procedures for M2BB components early in FY96.

First, the procedures were developed to inspect components of the M2BB basic set for inventory of Bailey Bridge assets at Sierra Army Depot. Then, these procedures were updated to also inspect components of the M2BB erection equipment set and conversion set to evaluate bridging assets at several Combat Equipment Companies in Europe.

The inspection procedures of the first version only classify components as serviceable with qualification or not serviceable with qualification. The procedures of the updated version classify components as Condition Code B, E, F, G, or H. All of these procedures are developed for use by soldiers with MOS 12C.

2. METHODS, ASSUMPTIONS, AND PROCEDURES

Early in FY96, ATCOM requested the SBT to develop procedures to inspect components of the M2BB basic set. The procedures would be used for inventory of M2BB assets at Sierra Army Depot. The procedures would explain how to examine M2BB components in order to inspect them and classify them as serviceable with qualification (Federal Condition Code B) or not Condition Code B. The target audience would be soldiers with MOS 12C.

Upon receipt of the request, the SBT prepared a plan to show how the procedures would be developed. The initial plan included the following:

1. Initial site visit
2. Review Existing Manuals
3. Develop inspection procedures for all components of the M2BB basic set
4. Review and Update Initial Draft
5. Approve Inspection Procedures

6. Train Inspectors
7. Inspect M-2 Bailey Bridge components using the developed procedures
8. Update and finalize the Inspection Procedures

Following this plan, two members of the SBT traveled to Sierra Army Depot from 9 to 11 January 1996 to investigate the conditions of the Bailey Bridge components there. The procedures were then developed based on these known conditions. The SBT completed the first version of the inspection procedures in June 1996. These procedures were developed to inspect all the components of the M2BB basic set which includes the Panel, Transom, Sway Brace, Plain Stringer, Button stringer, Chess, Riband, Raker, Bracing Frame, Bearing, Female End Post, Male End Post, Plain Ramp, Button Ramp, Aluminum Footwalk, Footwalk Bearer, Footwalk Post, Transom Clamp, Ramp Pedestal, Base Plate, Overhead Bracing Support, Panel Pin, Short Panel Pin, Tie Plate, Bracing Bolt, Chord Bolt, and Riband Bolt.

The procedures of each component or each group of components were presented on a page which contains four parts as follows:

1. Illustration of a component or a group of components with some major instructions;
2. Estimated time required to do the inspection;
3. Equipment and personnel required to do the inspection; and
4. Detailed inspection procedures.

Procedures for each component or each group of components explain how to examine the component(s) and look for rust and corrosion, loss of material from rust and corrosion, physical damage such as bending, dent, and crack, cracked or broken welds, and operability where applicable and to apply the Federal Condition Code B or not B for each event.

After being reviewed internally and by the TARDEC Materials & Environmental Packaging Special Processing Team, these procedures were used to train personnel at Sierra Army Depot to evaluate Bailey Bridge assets. The training occurred at this depot from 18 to 20 June 1996 with the observation of the Item Manager for Bridging of ATCOM. During this period, the SBT also explained how to inspect components of the M2BB erection equipment set and conversion set because there were some of these components at this location.

Early in the fourth quarter of FY96, ATCOM requested the SBT to update the inspection procedures to include components of the M2BB erection equipment set and conversion set for use to evaluate Bailey Bridge assets in Combat Equipment Group - Europe. The conditions of these bridges are unknown. The updated procedures would classify the inspected components using the following Federal Condition Codes:

- B (serviceable with qualification)
- E (limited restore)
- F (unserviceable but repairable)
- G (unserviceable - incomplete)
- H (unserviceable and condemned)

The SBT updated the inspection procedures per the request of ATCOM. According to Federal Logistics Data File, most Bailey Bridge components are non-repairable. However, these inspection procedures recommend Condition Code F (repairable) for several Bailey Bridge components due to the unavailability of new components. Condition Codes used in these procedures are F, G, and H. A component is classified as Condition Code B if it is not Condition Codes F, G, and H. A serviceable (Condition Code B) component, which has surface rust more than 20% of parent surface (but not excessive rust/corrosion) is still serviceable. Generally, the component is still useable if it is stored in covered storage. Otherwise, it needs to be re-painted (Condition Code E, limited restore).

The updated version also includes lists of all components of the M2BB for the basic set, erection equipment set, and conversion set, and description of these components.

Upon the completion of the update, these procedures were used to train personnel of the 16th, 18th, 19th, and 22nd Combat Equipment Companies (CECs) in Europe from 15 to 28 September 1996 to inspect components of M2BB basic set, erection equipment set, and conversion set.

In November 1996, the M-2 Bailey Bridge Component Inspection Procedures were finalized and put together as a manual. These procedures are developed for use by soldiers with MOS 12C.

3. RESULT & DISCUSSION

The result of this development is a manual of the M-2 Bailey Bridge Component Inspection Procedures shown in ANNEX 1.

The manual has 49 pages and contains the following:

- (1) Cover Page
- (2) Forward
- (3) Table of Contents
- (4) M-2 Bailey Bridge Component Inspection Procedures for the basic set, erection equipment set, and conversion set.
- (5) Appendix A lists all components of the M2BB for the basic set, erection equipment set, and conversion set.
- (6) Appendix B includes description of all M2BB components covered in this manual.

All the component sketches illustrated in this manual are reproduced from the Field Manual No. 5-277, Bailey Bridge.

Since the procedures do not use any test equipment and the target audience are soldiers with MOS 12C, the manual includes a definition of the term "excessive rust/corrosion". This term used in these procedures means that more than 15% of parent material for a given cross-sectional area, is rusted or corroded; this figure is a visual estimate.

The estimation of time required to do the inspection for each component listed in the manual is base on the weight of the component, its complicity, and hands-on experience during the Bailey Bridge assets at Sierra army Depot, and at several Combat Equipment Companies in Europe. These times are for inspection only and do not include time for handling.

4. CONCLUSION AND RECOMMENDATIONS

These inspection procedures have been used in Sierra Army Depot and in several Combat Equipment Companies in Europe and the result was very successful. The use of this manual is recommended.

5. DISTRIBUTION LIST

<u>ORGANIZATION</u>	<u>COPIES</u>
COMMANDER, US ARMY AVIATION - TROOP COMMAND WEAPON SYSTEMS MANAGER-ENGINEERING EQUIPMENT ATTN: AMSAT-D-WME 4001 GOODFELLOW DRIVE ST. LOUIS, MO 63120-1798	3
DEFENSE TECHNICAL INFORMATION CENTER ATTN: DTIC-BRR 8725 JOHN J. KINGMAN ROAD, SUITE 0944 FT. BELVOIR, VA 22060-6218	2
COMMANDER, US ARMY TANK-AUTOMOTIVE AND ARMAMENTS COMMAND DIRECTOR TARDEC ATTN: AMSTA-TR/204 WARREN, MI 48397-5000	1
COMMANDER, US ARMY TANK-AUTOMOTIVE AND ARMAMENTS COMMAND TECHNICAL DIRECTOR TARDEC ATTN: AMSTA-TR-R/202 WARREN, MI 48397-5000	1
COMMANDER, US ARMY TANK-AUTOMOTIVE AND ARMAMENTS COMMAND BUSINESS MANAGEMENT TEAM ATTN: AMSTA-TR-O/204 WARREN, MI 48397-5000	1
COMMANDER, US ARMY TANK-AUTOMOTIVE AND ARMAMENTS COMMAND SUPPORT BRIDGE TEAM ATTN: AMSTA-TR-R/21 WARREN, MI 48397-5000	5
COMMANDANT, US ARMY ENGINEER SCHOOL TRADOC SYSTEM MANAGER ATTN: ATSE-TSM FORT LEONARD WOOD, MO 65473	2
COMMANDANT, US ARMY ENGINEER SCHOOL DIRECTOR FOR COMBAT DEVELOPMENTS ATTN: ATSE-CDM FORT LEONARD WOOD, MO 65473	2
COMMANDANT, US ARMY ENGINEER SCHOOL DIRECTOR FOR TRAINING DEVELOPMENT ATTN: ATSE-T-TA-N FORT LEONARD WOOD, MO 65473	2
COMMANDER, US ARMY MATERIEL COMMAND ATTN: AMCDE-SD 5001 EISENHOWER AVE, ALEXANDRIA VA 22333-0001	2
COMMANDER, US ARMY TRAINING AND DOCTRINE COMMAND ATTN: ATCD-MR FORT MONROE, VA 23651	2
COMMANDER HEADQUARTERS COMBAT EQUIPMENT GROUP - EUROPE UNIT 21615 BOX 44 APO AE 09703	6
COMMANDER, SIERRA ARMY DEPOT ATTN: SIOSI-QA HERLONG, CA 96113-5000	5

6. ANNEX 1

M-2 BAILEY BRIDGE COMPONENT INSPECTION PROCEDURES

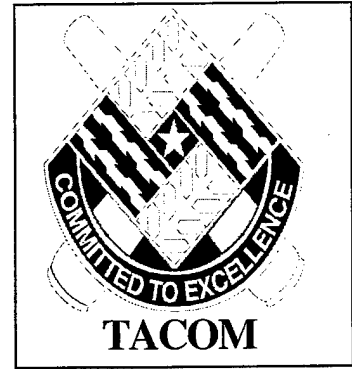
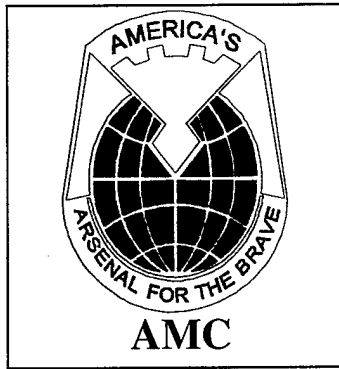

M-2 BAILEY BRIDGE COMPONENT INSPECTION PROCEDURES

FOR USE IN EUROPE

**Version 1.2
November 1996**

**SUPPORT BRIDGE TEAM
ENGINEERING & LOGISTICS EQUIPMENT BUSINESS AREA
AMSTA-TR-R/21**

FORWARD

1. The M-2 Bailey Bridge Component Inspection Procedures here-in are developed by the Support Bridge Team, Engineering & Logistics Equipment Business Area, AMSTA-TR-R/21, Warren. MI 48397-5000 for use in Europe.

2. Users are invited to provide beneficial comments (recommendations, additions, deletions) and any pertinent data which may be of use in improving this document to:

- (a) John D. Stanek, Support Bridge Team Leader
DSN 786-6012 or Commercial (810) 574-6012
e-mail address: stanekj@cc.tacom.army.mil
- (b) Anh V. Nguyen, Senior Project Engineer
DSN 786-6291 or Commercial (810) 574-6291
e-mail address: nguyenan@cc.tacom.army.mil
- (c) Clarence Aycock, Project Engineer
DSN 786-6252 or Commercial (810) 574-6252
e-mail address: aycockc@cc.tacom.army.mil

TABLE OF CONTENTS

M-2 Bailey Bridge Component Inspection Procedures	
M-2 Bailey Bridge Basic Set	2
M-2 Bailey Bridge Erection Equipment Set	17
M-2 Bailey Bridge Conversion Set	26
Appendix A	
A-1: Components of a M-2 Bailey Bridge Basic Set	35
A-2: Components of a M-2 Bailey Bridge Erection Equipment Set	36
A-3: Components of a M-2 Bailey Bridge Conversion Set	37
Appendix B	
B-1: M-2 Bailey Bridge Component Description Basic Set	39
B-2: M-2 Bailey Bridge Component Description Erection Equipment Set	43
B-3: M-2 Bailey Bridge Component Description Conversion Set	45

M-2 BAILEY BRIDGE COMPONENT INSPECTION PROCEDURES

These procedures cover the inspection of M-2 Bailey Bridge sets in Europe. Procedures for all main components for the basic set, erection equipment set, and conversion set are outlined.

A listing of complete components of the M-2 Bailey Bridge is given Appendix A.

Appendix B provides a brief description of all components covered in the procedures.

According to Federal Logistics Data File, most Bailey Bridge components are non-repairable. However, these inspection procedures recommend Condition Code F (repairable) for several Bailey Bridge components due to the unavailability of new components.

These inspection procedures classify components using the following Federal Condition Codes:

- B (serviceable with qualification)
- E (limited restore)
- F (unserviceable but repairable)
- G (unserviceable - incomplete)
- H (unserviceable and condemned)

A component is Condition Code B (serviceable with qualification) if it is not Condition Codes F, G, and H.

A serviceable (Condition Code B) component, which has surface rust more than 20% of parent surface (but not excessive rust/corrosion) is still serviceable. Generally, the component is still useable if it is stored in covered storage. Otherwise, it needs to be re-painted (Condition Code E, limited restore).

The term "Excessive rust/corrosion" means that more than 15% of parent material for a given cross-sectional area, is rusted or corroded. This figure is a visual estimate.

M-2 BAILEY BRIDGE
BASIC SET

PANEL

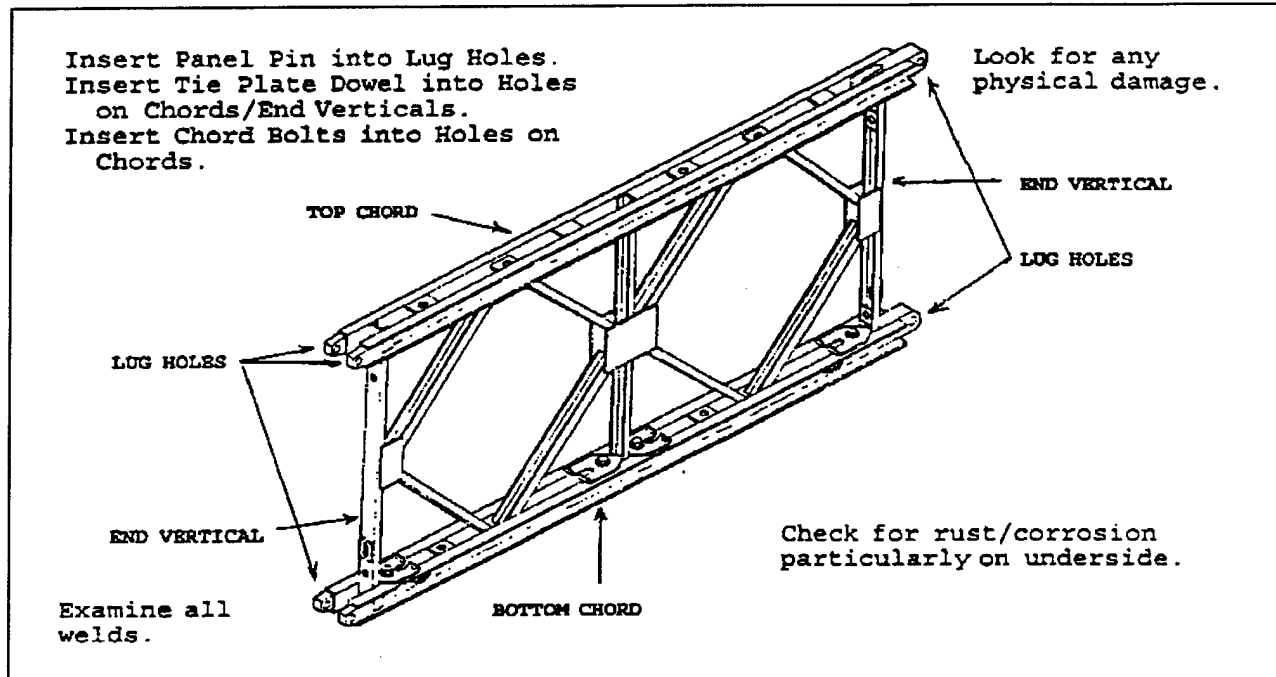

Time Required: 2:00 mins/Panel

Equipment/Personnel Required:

1. Sufficient personnel and/or equipment necessary to lift, move, and rotate a Panel. Six to seven personnel suggested.
2. A clean Panel Pin, a clean Chord Bolt, and a Tie Plate with Dowels.

Inspection Procedures:

1. Examine the entire surface of the Panel including underside.
Any of the following indicates that Panel is Condition Code F:
 - A. Excessive rust/corrosion, visible loss of material from rust/corrosion on other members than chords and end verticals.
 - B. 'Dimpling' on surface of painted members. (This indicates that the Panel rusted in the past and was then repainted.)
 - C. Rust in pin/bolt holes. (If any rust is present then ensure Panel Pin/Chord Bolt/Tie Plate Dowel can still be inserted in proper hole. The Panel is OK if Panel Pin/Chord Bolt/Tie Plate Dowel can be inserted.)Any of the following indicates that Panel is Condition Code H:
 - A. Excessive rust/corrosion, visible loss of material from rust/corrosion on chords and end verticals.
2. Look for any physical damage.
Any of the following indicates that Panel is Condition Code F:
 - A. Bent members (Except chords and end verticals).
 - B. Cracks in any member (Except chords and end verticals).
 - C. Badly nicked or dented members.Any of the following indicates that the Panel is Condition Code H:
 - A. Bent chords and end verticals.
 - B. Cracks in chords and end verticals.
3. Look for cracked or broken welds. Any such weld indicates that Panel is Condition Code F.

TRANSOM

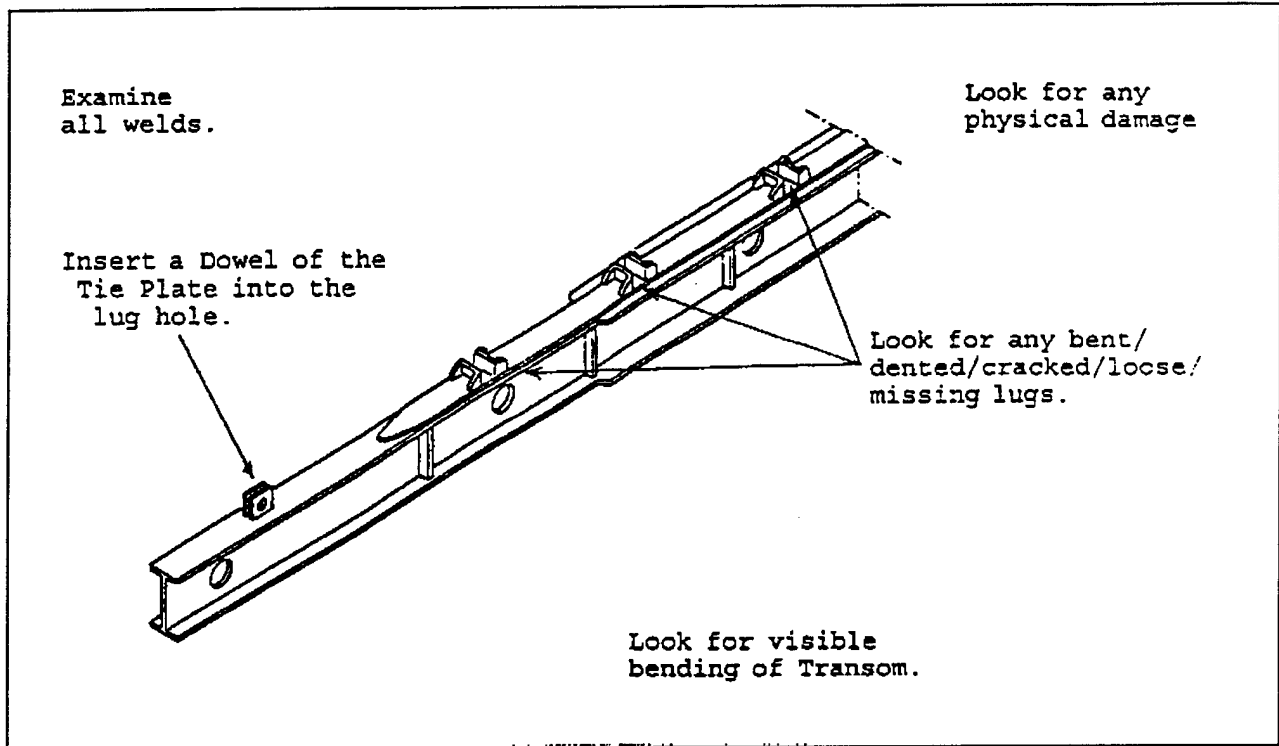

Time Required: 2:00 mins/Transom

Equipment/Personnel Required:

1. Sufficient personnel and/or equipment necessary to lift, move, and rotate a Transom. Eight personnel suggested.
2. A clean Tie Plate with Dowels.

Inspection Procedures:

1. Examine the entire Transom including its underside.
Any of the following indicates that Transom is Condition Code H:
 - A. Excessive rust/corrosion and visible loss of material from rust/corrosion on the I-beam, especially where the Transom was resting on the ground.Any of the following indicates that Transom is Condition Code F:
 - A. Excessive rust/corrosion and visible loss of material from rust/corrosion on other members than the I-beam.
 - B. Rust in lug holes. (If any rust is present then ensure a Dowel of the Raker can still be inserted. The Transom is OK if a Dowel of the Tie Plate can be inserted.)
2. Look for any physical damage.
Any of the following indicates that Transom is Condition Code H:
 - A. Visible bending of the Transom.Any of the following indicates that Transom is Condition Code F:
 - A. Bent lugs.
 - B. Badly dented lugs.
 - C. Cracked/loose lugs
 - D. Missing lugs.
3. Look for cracked or broken welds. Any such weld indicates that Transom is Condition Code F.

SWAY BRACE

Unfold and Fold Sway Brace.

Turn Turnbuckle & Lock Nut.

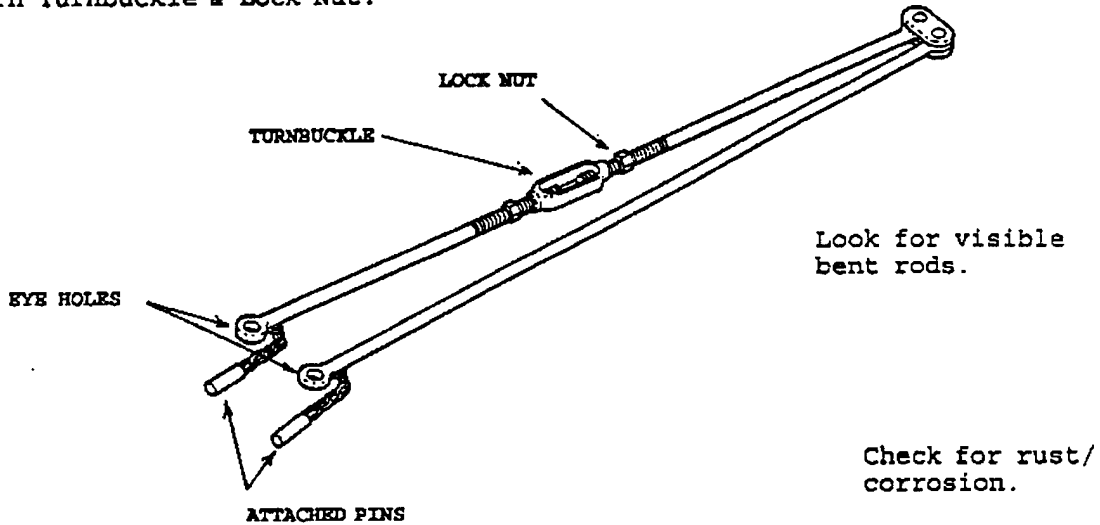

Insert attached Pin into its Eye Hole.

Time Required: 2:00 mins/Sway Brace

Equipment/Personnel Required:

1. Sufficient personnel necessary to lift and unhinge a Sway Brace. Two personnel suggested.
2. Lubricant.
3. An erection wrench.

Inspection Procedures:

1. Examine the entire surface of the Sway Brace.
Any of the following indicates that Sway Brace is Condition Code H:
A. Excessive rust/corrosion and visible loss of material from rust/corrosion.
Any of the following indicates that Sway Brace is Condition Code F:
A. Rust in eye holes. (If any rust is present then ensure the attached pin can still be inserted. Sway Brace is OK if the attached pin can be inserted.)
2. Look for any physical damage.
Any of the following indicates that Sway Brace is Condition Code H:
A. Bent rods or turnbuckles.
B. Damaged threads on rod ends.
Any of the following indicates that Sway Brace is Condition Code G:
A. Missing pins or no lock nut.
3. Ensure the Sway Brace can still be operated. If any of the following cannot be performed this indicates that Sway Brace is Condition Code F.
A. Unfold and fold the Sway Brace.
B. Turn turnbuckle and lock nut.
Lubricant can be used to loosen up stiff members. The Sway Brace is OK if it operates after lubrication.

STRINGER

Check for rust/corrosion.
Look for any physical damage.
Examine all welds.

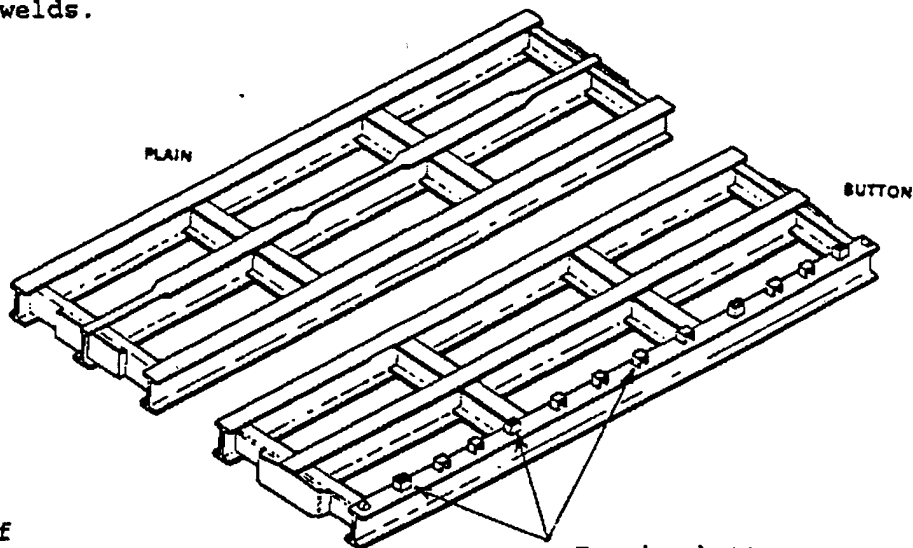

Check ends of
center member.

Examine buttons
(Button Stringers
Only).

Time Required: 2:00 mins/Stringer

Equipment/Personnel Required:

Sufficient personnel and/or equipment necessary to lift, move, and rotate a Stringer. Five or four personnel suggested.

Inspection Procedures:

1. Examine the entire surface of the Stringer.
 - Any of the following indicates that Stringer is Condition Code H:
 - A. Excessive rust/corrosion and visible loss of material from rust/corrosion on the three main I-beams.
 - Any of the following indicates that Stringer is Condition Code F:
 - A. Excessive rust/corrosion and visible loss of material from rust/corrosion on other members than the three main I-beams.
2. Look for any physical damage.
 - Any of the following indicates that Stringer is Condition Code F:
 - A. Bent members (Except the three main I-beams).
 - B. Badly nicked/dented/cracked members (Except the three main I-beams).
 - Pay particular attention to the buttons on the Button Stringers. Bent buttons may prevent the Chess from being laid between them. Visually check distance between bent buttons to ensure Chess will fit. Check ends of center member. If bent, it may mean that the Stringer can no longer be placed on a Transom.
 - Any of the following indicates that Stringer is Condition Code H:
 - A. Bent main I-beams.
 - B. Badly nicked/dented/cracked main I-beams.
3. Look for cracked or broken welds. Any such weld indicates that Stringer is Condition Code F.

CHES

Look for rot and warpage.
Look for gouges and missing material.
Examine both sides.

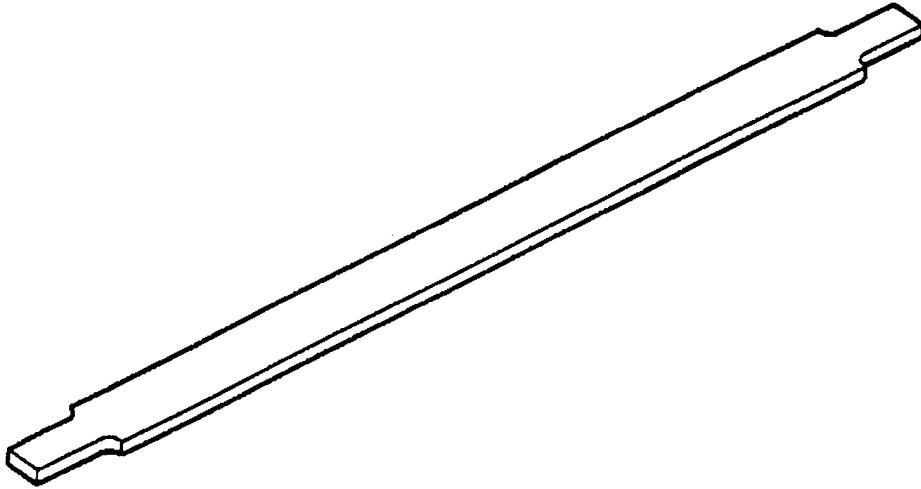

Time Required: 10:00 mins/Bundle of 16 Chess

Equipment/Personnel Required:

Sufficient personnel and/or equipment necessary to lift, move, and rotate a Chess. Two personnel suggested.

Inspection Procedures:

Examine the entire surface of the Chess. Any of the following indicates that Chess is Condition Code H:

- A. Large gouges or missing material.
- B. Rot. Pay particular attention to the Chess in the interior of bundles, towards the bottom. Water may collect in between the Chess and accelerate rot. Also pay attention to the Chess missing paint or which is unpainted. The Chess without the protection of paint is more susceptible to rot.
- C. Warped Chess. Excessive warpage indicates the Chess may not lay flat on Stringers.

RIBAND

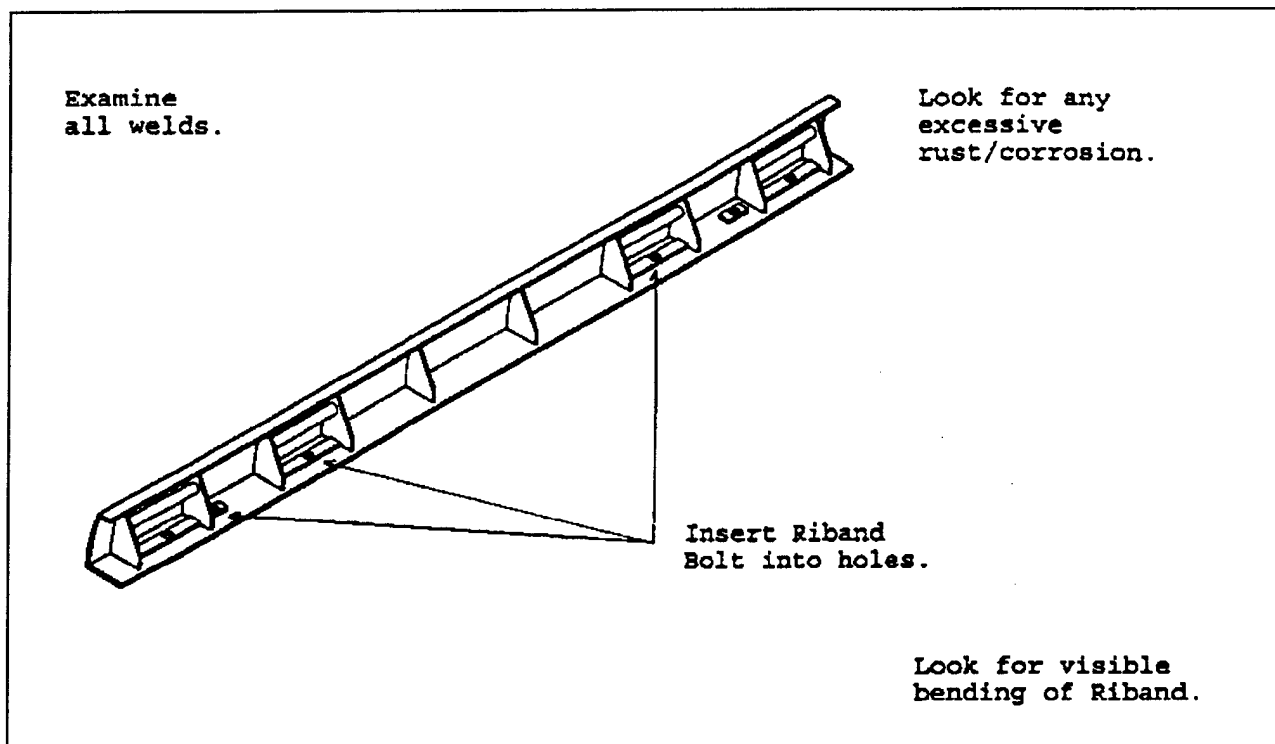

Time Required: 1:00 min/Riband

Equipment/Personnel Required:

1. Sufficient personnel and/or equipment necessary to lift, move, and rotate a Riband. Four personnel suggested.
2. A clean Riband Bolt.

Inspection Procedures:

1. Examine the entire Riband.
Any of the following indicates that Riband is Condition Code F:
 - A. Excessive rust/corrosion and visible loss of material from rust/corrosion.
 - B. Rust in the Riband holes. (If any rust is present then ensure a Riband Bolt can still be inserted. The Riband is OK if a Riband Bolt can be inserted.)Any of the following indicates that Riband is Condition Code H:
 - A. Visible bending of the Riband.
2. Look for cracked or broken welds. Any such weld indicates that Riband is Condition Code F.

RAKER & BRACING FRAME

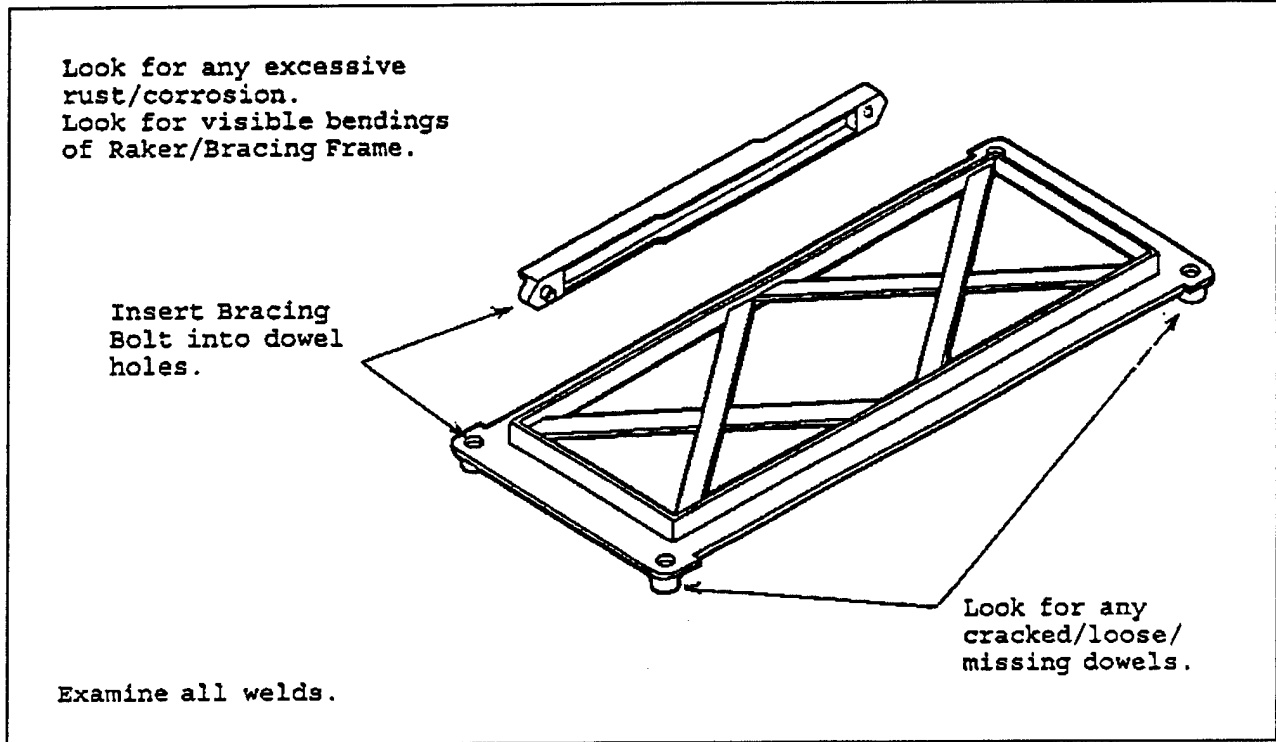

Time Required: 1:00 min/3 Rakers and 2:00 mins/3 Bracing Frames

Equipment/Personnel Required:

1. Sufficient personnel and/or equipment necessary to lift, move, and rotate a Raker/Bracing Frame. Two personnel suggested.
2. One clean Bracing Bolt.

Inspection Procedures:

1. Examine the entire Raker/Bracing Frame. Any of the following indicates that Raker/Bracing Frame is Condition Code F:
 - A. Excessive rust/corrosion and visible loss of material from rust/corrosion.
 - B. Rust in dowel holes. (If any rust is present then ensure a Bracing Bolt can still be inserted. The Raker/Bracing Frame is OK if a Bracing Bolt can be inserted.)

2. Look for any physical damage.

Any of the following indicates that Raker/Bracing Frame is Condition Code

H:

- A. Visible bending of the Raker/Bracing Frame.

Any of the following indicates that Raker/ Bracing Frame is Condition Code

F:

- A. Cracked/loose dowels.
- B. Missing dowels.

3. Look for any cracked/broken welds. Any such weld indicates that Raker/ Bracing Frame is Condition Code F.

BEARING (BEARING SHOE) & END POST

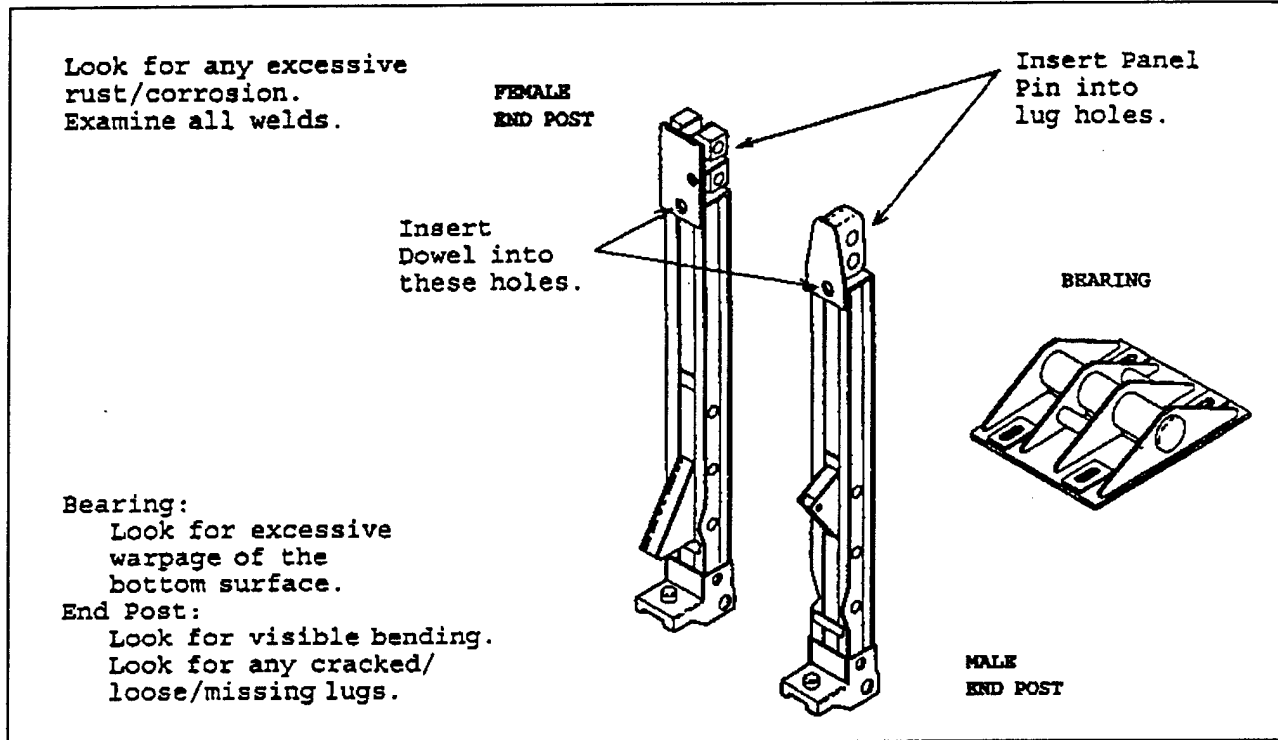

Time Required: 1:00 min/3 Bearings and 1:00 min/2 End Posts

Equipment/Personnel Required:

1. Sufficient personnel and/or equipment necessary to lift, move, and rotate a Bearing/End Post. Three personnel suggested for End Post and two for Bearing Post.
2. One clean Panel Pin and one Tie Plate with Dowels for End Post.

Inspection Procedures:

1. Examine the entire Bearing/End Post.
Any of the following indicates that Bearing/End Post is Condition Code H:
A. Excessive rust/corrosion and visible loss of material from rust/corrosion.
Any of the following indicates that Bearing/End Post is Condition Code F:
A. Rust in holes (End Post only). (If any rust is present then ensure a Panel Pin/Tie Plate Dowel can still be inserted. The End Post is OK if a Panel Pin/Tie Plate Dowel can be inserted.)
2. Look for any physical damage.
Any of the following indicates that Bearing/End Post is Condition Code H:
A. Excessive warpage of the bottom surface (Bearing only).
B. Visible bending.
Any of the following indicates that End Post is Condition Code F:
A. Cracked/loose lugs.
B. Missing lugs.
3. Look for any cracked/broken welds. Any such weld indicates that Bearing/End Post is Condition Code F.

RAMP

Check for rust/corrosion.
Look for any physical damage.
Examine all welds.

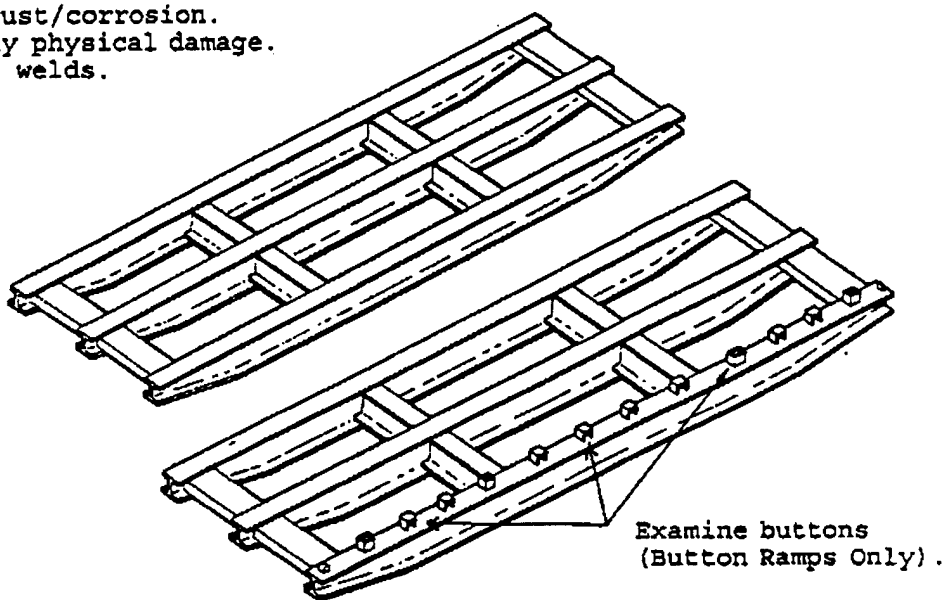

Time Required: 2:00 mins/Ramp

Equipment/Personnel Required:

Sufficient personnel and/or equipment necessary to lift, move, and rotate a Ramp. Six personnel suggested.

Inspection Procedures:

1. Examine the entire surface of the Ramp.
 - Any of the following indicates that Ramp is Condition Code H:
 - A. Excessive rust/corrosion and visible loss of material from rust/corrosion on the three main I-beams.
 - Any of the following indicates that Ramp is Condition Code F:
 - A. Excessive rust/corrosion and visible loss of material from rust/corrosion on other members than the three main I-beams.
2. Look for any physical damage.
 - Any of the following indicates that Ramp is Condition Code F:
 - A. Bent members (Except the three main I-beams).
 - B. Badly nicked/dented/cracked members (Except the three main I-beams).
 - Pay particular attention to the buttons on the Button Ramp. Bent buttons may prevent the chess from being laid between them. Visually check distance between bent buttons to ensure the chess will fit.
 - Any of the following indicates that Ramp is Condition Code H:
 - A. Bent main I-beams.
 - B. Badly nicked/dented/cracked main I-beams.
3. Look for any cracked/broken welds. Any such weld indicates that Ramp is Condition Code F.

WOODEN FOOTWALK

Look for rot and warpage.
Look for gouges and missing material.
Examine both sides.
Look for any loose/missing bolts and nuts.

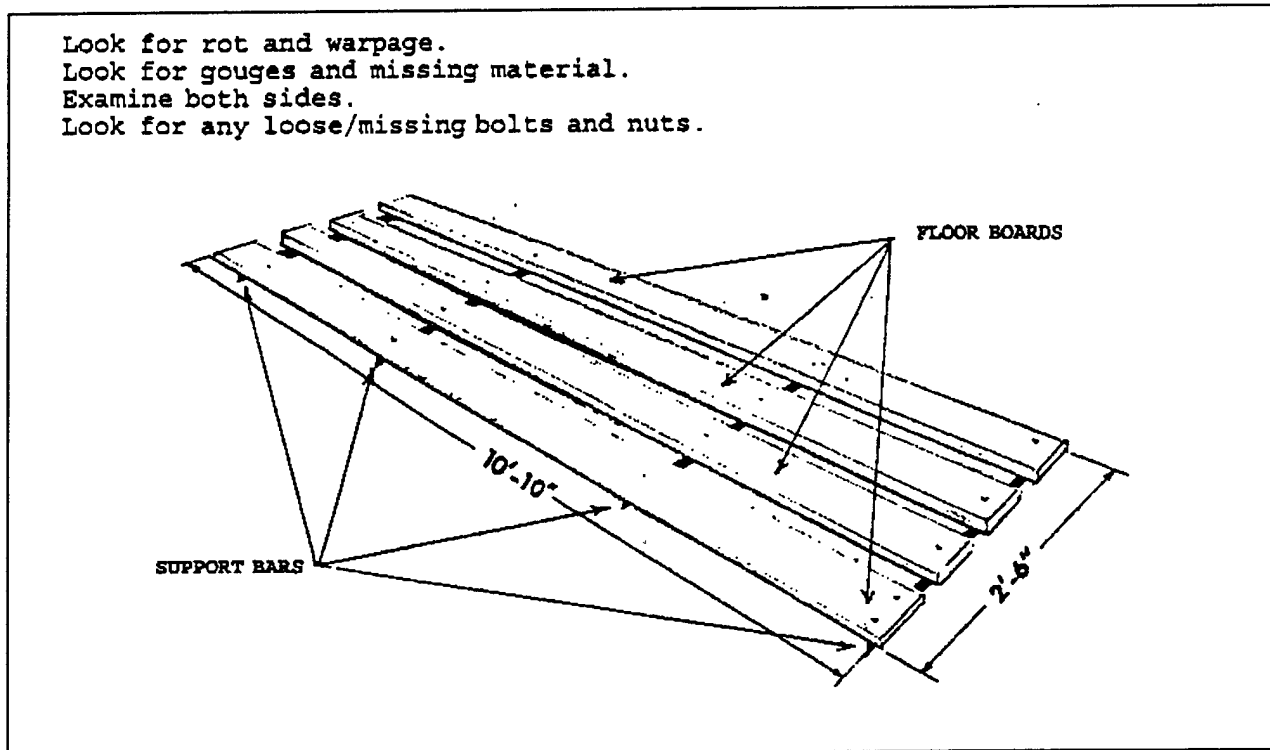

Time Required: 2:00 mins/Footwalk

Equipment/Personnel Required:

Sufficient personnel and/or equipment necessary to lift, move, and rotate a Footwalk. Four personnel suggested.

Inspection Procedures:

1. Examine the entire surface of the wooden Footwalk. Any of the following indicates that Footwalk is Condition Code F:

- A. Warpage (floor boards or support bars).
- B. Large gouges.
- C. Missing material.
- D. Rot.

2. Look for any physical damage.

Any of the following indicates that Footwalk is Condition Code F:

- A. Missing members.
- B. Cracked/loose members.
- C. Damaged bolts/nuts.

Any of the following indicates that Footwalk is Condition Code G:

- A. Missing bolts/nuts.

ALUMINUM FOOTWALK, FOOTWALK BEARER & FOOTWALK POST

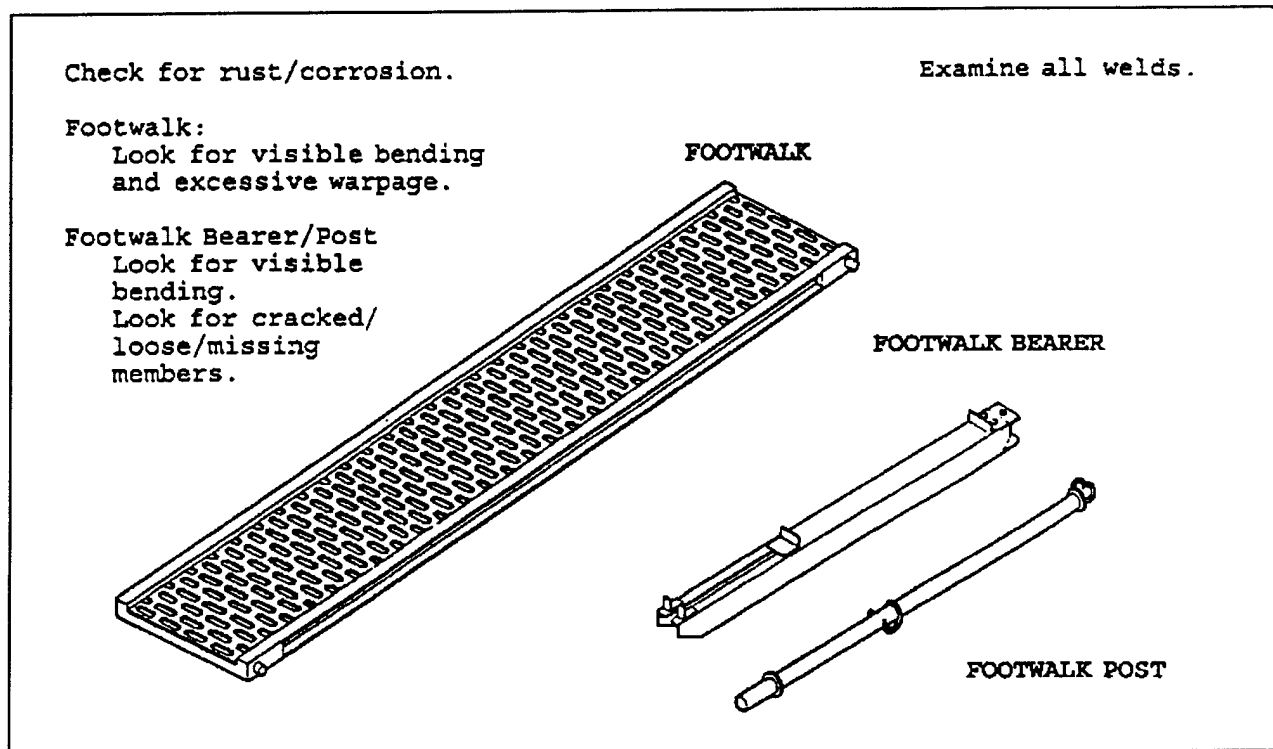

Check for rust/corrosion.

Examine all welds.

Footwalk:
Look for visible bending
and excessive warpage.

FOOTWALK

Footwalk Bearer/Post
Look for visible
bending.
Look for cracked/
loose/missing
members.

FOOTWALK BEARER

FOOTWALK POST

Time Required: 3:00 mins/5 Footwalks, 5 Bearers or 10 Posts

Equipment/Personnel Required:

Sufficient personnel and/or equipment necessary to lift, move, and rotate a Footwalk, Footwalk Bearer, or Post. Four personnel suggested for a Footwalk and one for a Footwalk Bearer or a Footwalk Post.

Inspection Procedures:

1. Examine the entire surface of the Footwalk/Footwalk Bearer/Footwalk Post.
Any of the following indicates that Footwalk/Footwalk Bearer/Footwalk Post is Condition Code F:
 - A. Excessive rust/corrosion and visible loss of material from rust/corrosion.
2. Look for any physical damage.
Any of the following indicates that Footwalk/Footwalk Bearer/Footwalk Post is Condition Code H:
 - A. Visible bending, excessive warpage (Footwalk).
 - B. Visible bending (Bearer and Post).Any of the following indicates that Footwalk Bearer or Post is Condition Code F:
 - A. Cracked/loose members.
 - B. Missing members.
3. Look for any cracked/broken welds. Any such weld indicates that Footwalk/Footwalk Bearer/Footwalk Post is Condition Code F.

TRANSOM CLAMP & RAMP PEDESTAL

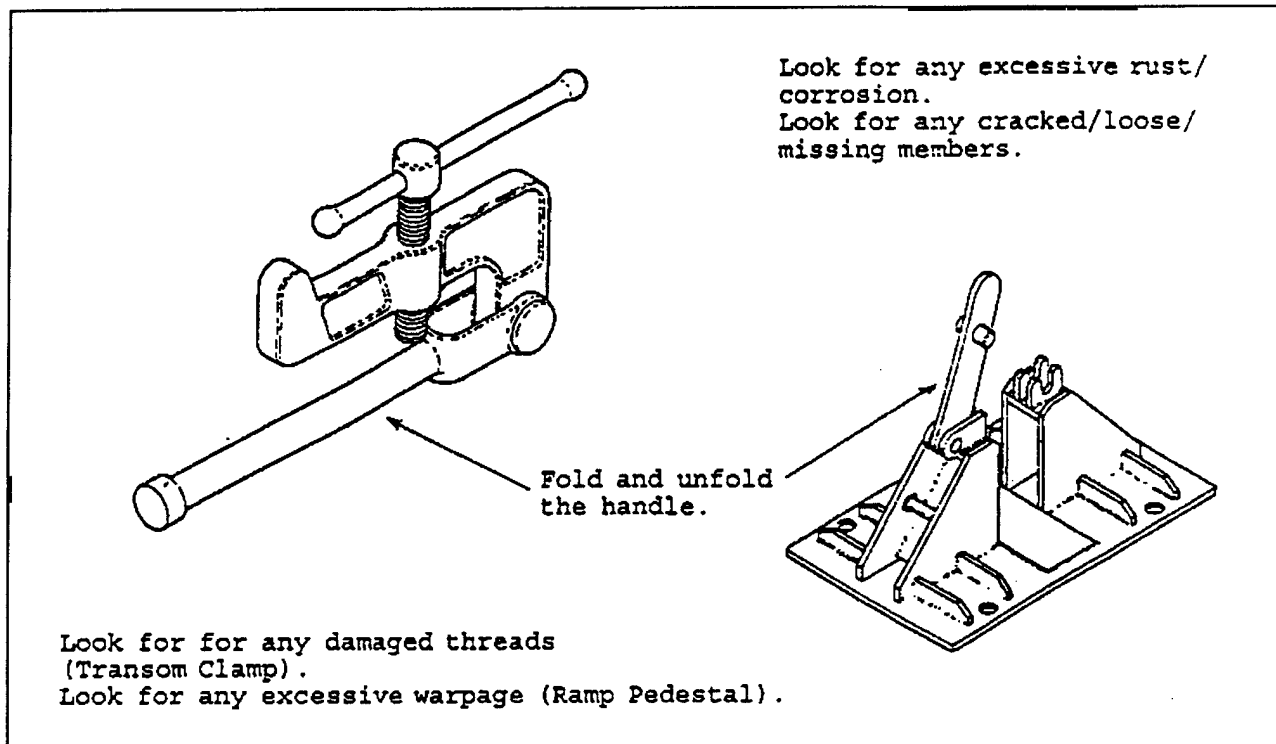

Time Required: 2:00 mins/5 Transom Clamps or 3 Ramp Pedestals

Equipment/Personnel Required:

1. One personnel suggested for a Transom Clamp. Sufficient personnel and/or equipment necessary to lift, move, and rotate a Ramp Pedestal, two personnel are suggested.
2. Lubricant.

Inspection Procedures:

1. Examine the entire Transom Clamp/Ramp Pedestal. Any of the following indicates that Transom Clamp/Ramp Pedestal is Condition Code H:
 - A. Excessive rust/corrosion and visible loss of material from rust/corrosion.
2. Look for any physical damage.
Any of the following indicates that Clamp/Pedestal is Condition Code F:
 - A. Cracked/loose/missing members.
 - B. Damaged threads (Transom Clamp only).Any of the following indicates that Ramp Pedestal is Condition Code H:
 - A. Excessive warpage of the bottom surface of the Ramp Pedestal.
3. Ensure Transom Clamp/Ramp Pedestal can still be operated. If any of the following cannot be performed this indicates that Transom Clamp/Ramp Pedestal is Condition Code F:
 - A. Fold and unfold the handle.
 - B. Turn the threaded member (Transom Clamp only).Lubricant can be used to loosen up stiff members. The Transom Clamp/Ramp Pedestal is OK if it operates after lubrication.

BASE PLATE, & OVERHEAD BRACING SUPPORT

Check for excessive rust/corrosion.

Look for:

Bending/cracks.

Missing Members.

Loss of Materials.

Excessive warpage

(Overhead Bracing

Support).

Examine all welds.

OVERHEAD BRACING SUPPORT

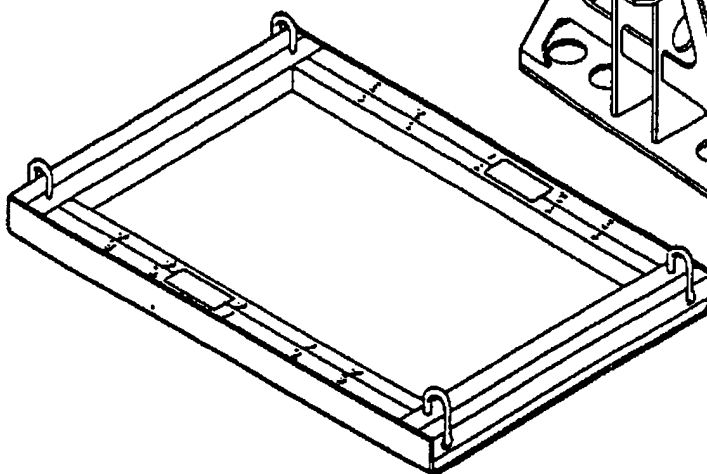
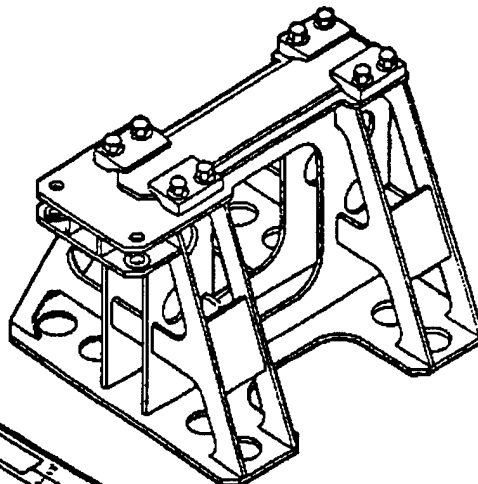

BASE PLATE

Time Required: 1:00 min/Base Plate and 2:00 mins/Overhead Bracing Support

Equipment/Personnel Required:

1. Sufficient personnel and/or equipment necessary to lift, move, and rotate a Base Plate/Overhead Bracing Support. Four five personnel suggested for an Overhead Bracing Support and 6 for a Base Plate.

Inspection Procedures:

1. Examine the entire surface of the Base Plate/Overhead Bracing Support. Any of the following indicates that these items are Condition Code H:

A. Excessive rust/corrosion and visible loss of material from rust/corrosion.

2. Look for any physical damage.

Any of the following indicates that these items are Condition Code F:

A. Cracked/missing members.

Any of the following indicates that these items are Condition Code H:

A. Visible bending.

B. Excessive warpage of top and bottom surface of Overhead Bracing Support.

3. Look for any cracked/broken welds. Any such weld indicates that these items are Condition Code F.

PANEL PIN, SHORT PANEL PIN, TIE PLATE,
BRACING BOLT, CHORD BOLT, RIBAND BOLT

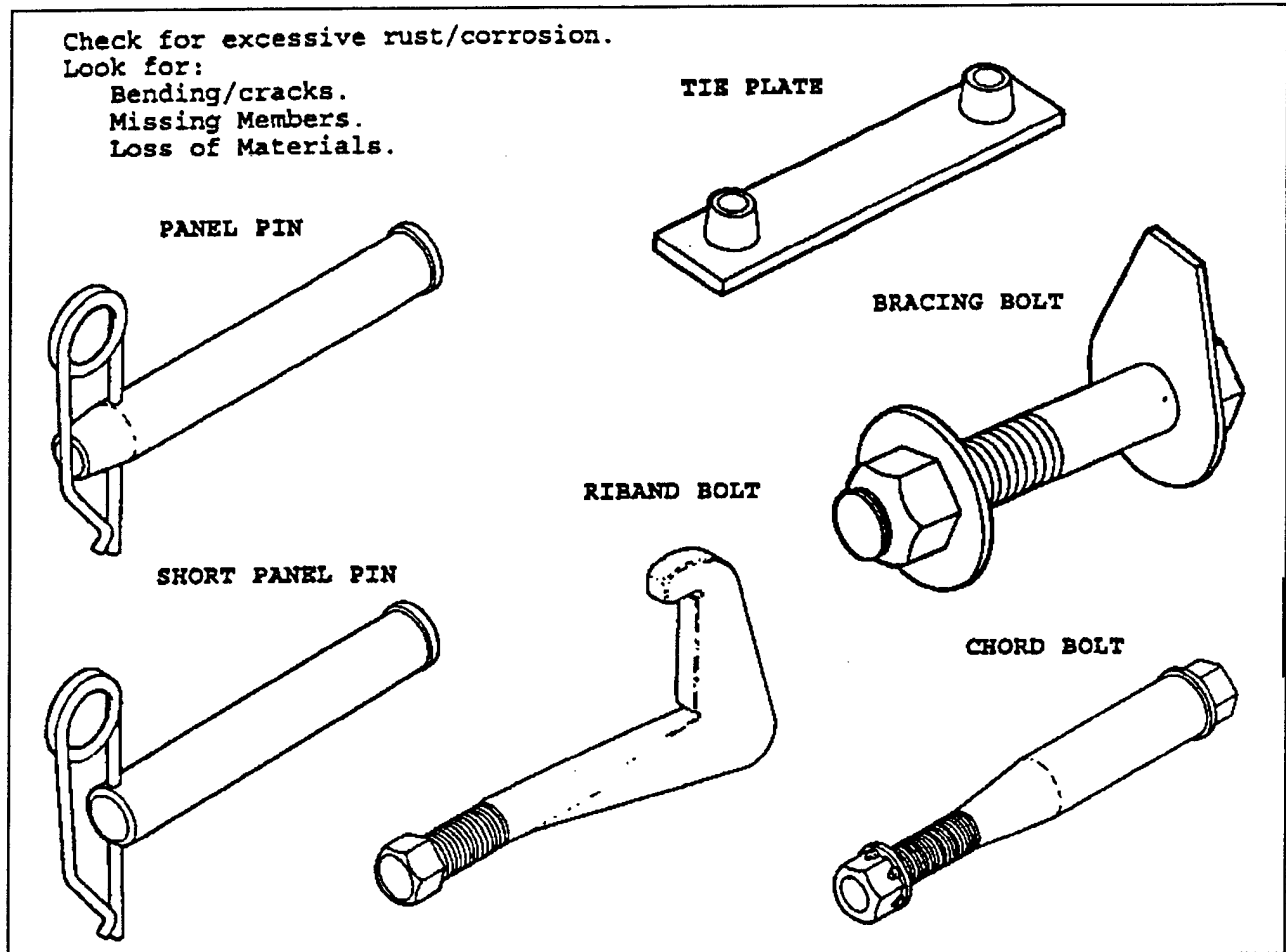

Time Required: 2:00 mins/container

Equipment/Personnel Required:

1. Sufficient personnel and/or equipment necessary to lift, move containers or pallets of these items. Two personnel suggested.

Inspection Procedures:

1. Visual and random check only. Any of the following indicates that these items are Condition Code F:

- A. Excessive rust/corrosion.
- B. Bending/cracks.
- C. Damaged threads (Bracing Bolt/Chord Bolt/Riband Bolt).
- D. Visible loss of material from rust/corrosion.
- E. (For Tie Plate only) If a bracing bolt cannot be inserted into dowels of the Tie Plate.

2. Any of the following indicates that Panel Pin/Short Panel Pin/Bracing Bolt/Chord Bolt/Riband Bolt is Condition Code G:

- A. Missing pin retainer or nut.

M-2 BAILEY BRIDGE
ERECTION EQUIPMENT SET

ROCKING ROLLER

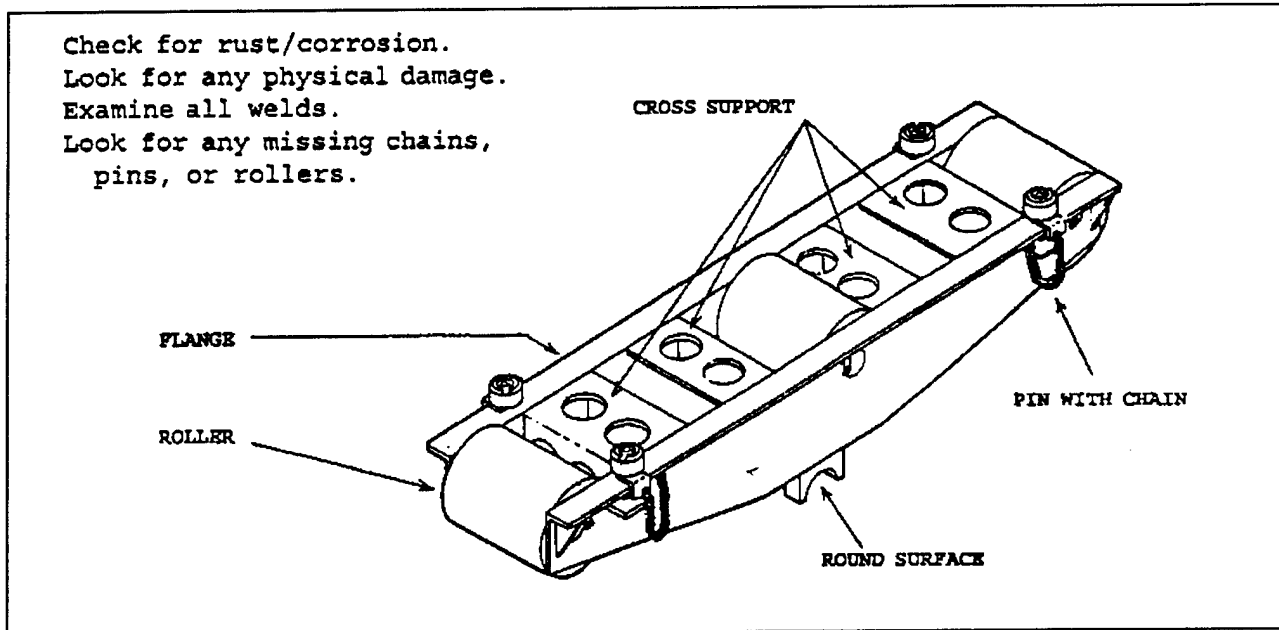

Time Required: 2:00 mins/Rocking Roller

Equipment/Personnel Required:

1. Sufficient personnel and/or equipment necessary to lift and move a Rocking Roller. Four personnel suggested.

Inspection Procedures:

1. Examine the entire Rocking Roller. Any of the following indicates that Rocking Roller is Condition Code H:

A. Excessive rust/corrosion, visual loss of material from rust/corrosion.

2. Look for any physical damage.

Any of the following indicates that Rocking Roller is Condition Code H:

A. Bending or distortion of the flanges, or cross-supports, which keeps the rollers from rolling.

B. Damage to the rollers such that they are no longer round.

C. Broken roller axles; cracked members.

D. Damage/distortion such that the three rollers are no longer in line.

Any of the following indicates that Rocking Roller is Condition Code F:

A. Main rollers or side rollers cannot roll freely.

B. Side rollers cannot be removed from the flanges.

C. Chains are not attached to the frame.

D. The round surface which fits over the bearing is damaged or worn such that the Rocking Roller cannot freely rock on the bearing.

Any of the following indicates that Rocking Roller is Condition Code G:

A. Missing pins.

B. Missing side rollers.

3. Look for cracked and broken welds. Any such weld indicates that Rocking Roller is Condition Code F.

PLAIN ROLLER & TRANSOM ROLLER

Check for rust/corrosion.
Look for any physical damage.
Examine all welds.

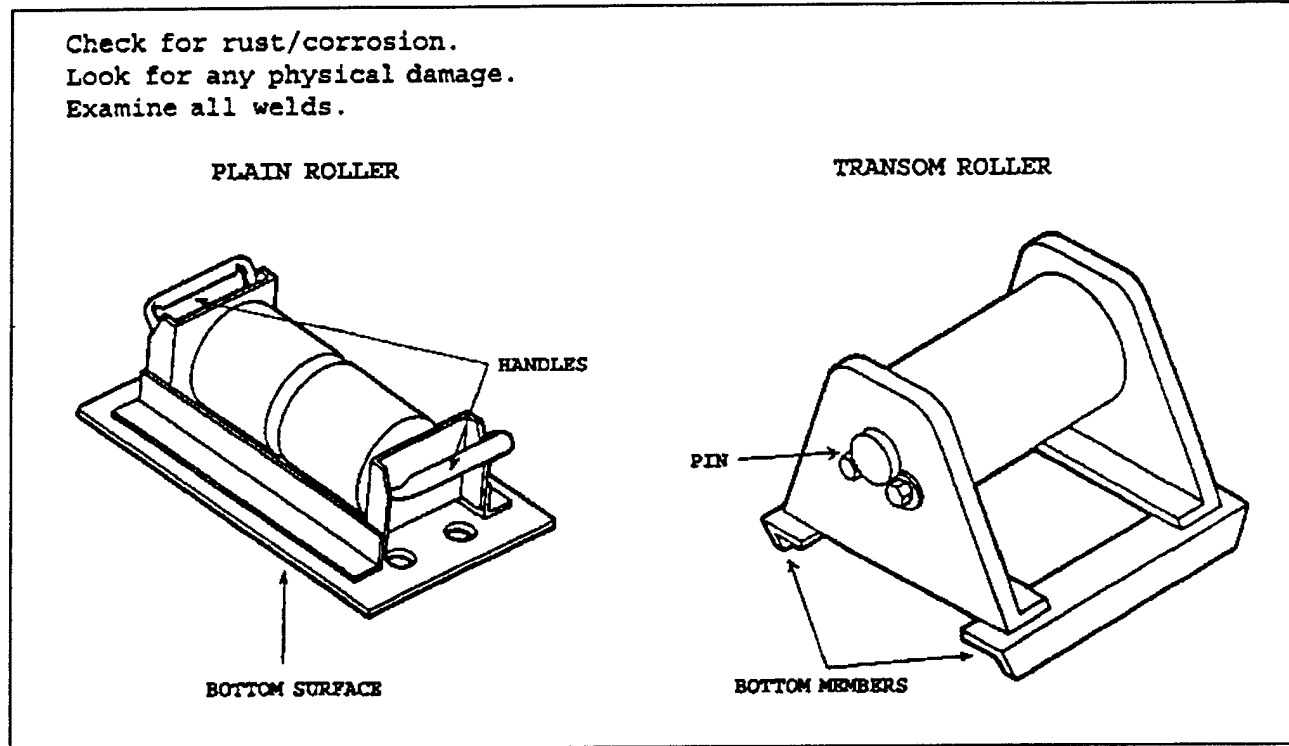

Time Required: 1:00 min/Plain or Transom Roller.

Equipment/Personnel Required:

1. Sufficient personnel and/or equipment necessary to lift and move a Plain Roller or Transom Roller. Two personnel suggested for Plain Roller and one for Transom Roller.

Inspection Procedures:

1. Examine the entire Plain Roller/ Transom Roller. Any of the following indicates that Plain Roller/Transom Roller is Condition Code H:

A. Excessive rust/corrosion, visual loss of material from rust/corrosion.

2. Look for any physical damage.

Any of the following indicates that Plain Roller/Transom Roller is Condition Code H:

A. Bending/distortion of members of the Plain Roller/Transom Roller which keeps the roller from freely rolling.

B. Severe warpage on the bottom surface of the Plain Roller or severe bending of the bottom members for the Transom Roller.

C. Badly distorted/dented rollers.

Any of the following indicates that Plain Roller/Transom Roller is Condition Code F:

A. The roller cannot roll freely.

B. Missing or broken handles.

3. Look for cracked and broken welds. Any such weld indicates that Plain Roller/Transom Roller is Condition Code F.

JACK & JACK SHOE

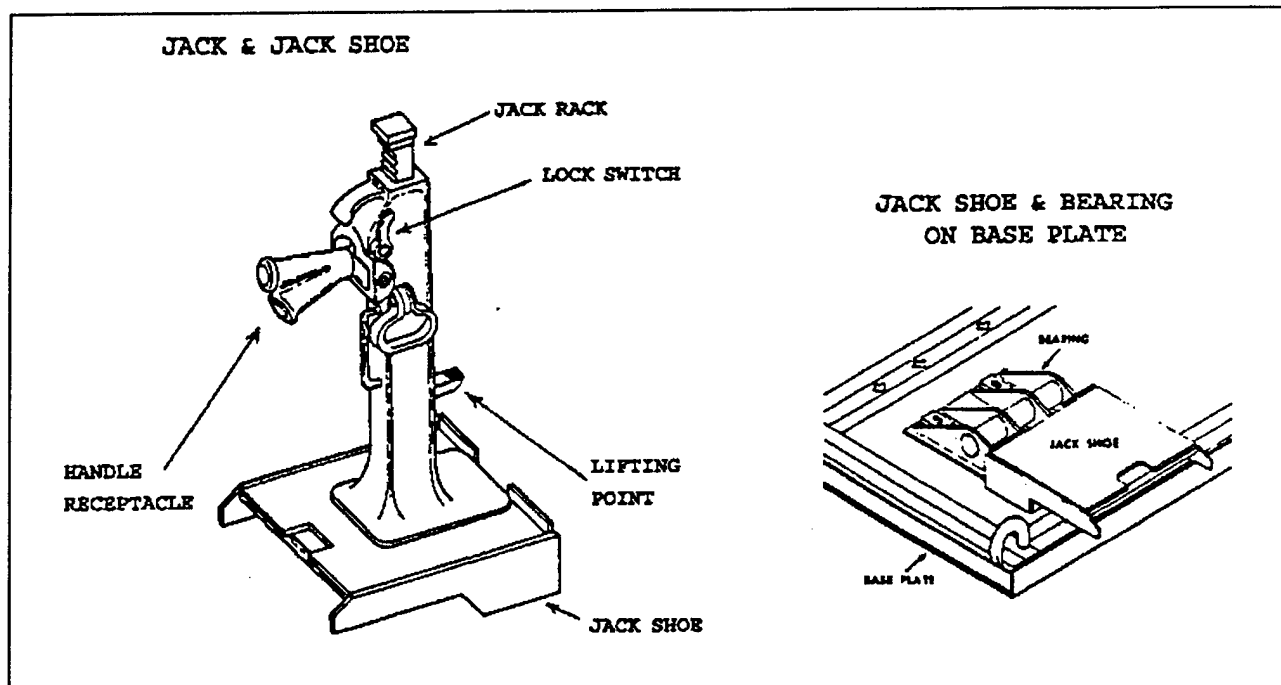

Time Required: 2:00 mins/Jack and Jack Shoe

Equipment/Personnel Required:

1. Sufficient personnel necessary to lift and move a Jack and Jack Shoe. Two personnel suggested.

Inspection Procedures:

1. Examine the entire Jack and Jack Shoe. Any of the following indicates that Jack/Jack Shoe is Condition Code H:
 - A. Excessive rust/corrosion, visual loss of material loss from rust/corrosion.
2. Look for any physical damage.
 - Any of the following indicates that Jack/Jack Shoe is Condition Code H:
 - A. Severe bending or distortion of the Jack which keeps it from standing firmly on a flat surface or from functioning properly.
 - B. Severe bending or distortion of the Jack Shoe which keeps it from staying firmly over a bearing or on a base plate.
 - C. Broken/worn teeth on the jack rack.
 - D. Missing parts; excessive wear of moving parts.
 - E. Bent, cracked or broken lifting point or lock switch.
 - Any of the following indicates that Jack/Jack Shoe is Condition Code F:
 - A. Handle cannot be properly inserted into the handle receptacle.
 - B. Jack does not lock in up position or does not descent.
 - Any of the following indicates that Jack is Condition Code G:
 - A. Missing a handle.
3. Look for cracked and broken welds. Any such weld indicates that Jack Shoe is Condition Code F.

PANEL LEVER

Look for any physical damage.
Look for rot or bending/twisting.
Examine all welds

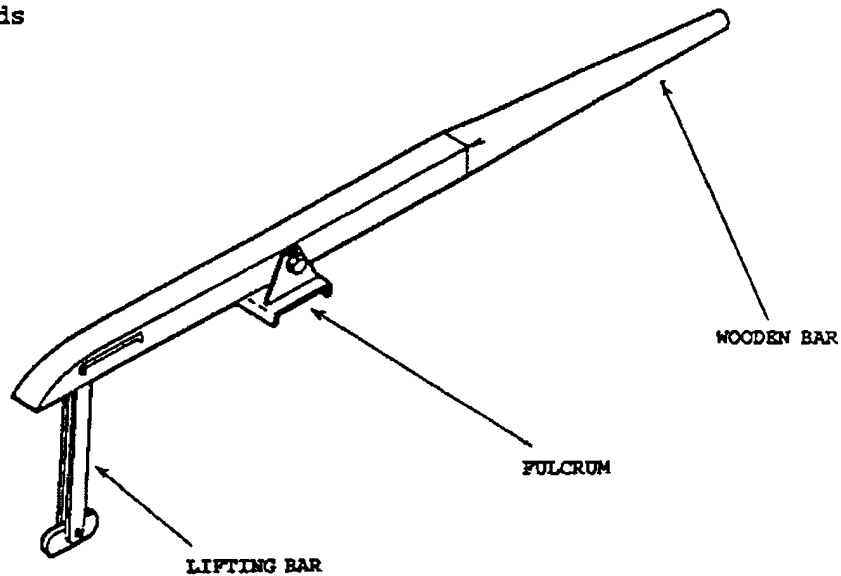

Time Required: 1:00 min/Panel Lever

Equipment/Personnel Required:

Sufficient personnel necessary to lift, move, and rotate a Panel Lever.
Two personnel suggested.

Inspection Procedures:

1. Examine the entire Panel Lever and look for any physical damage.
Any of the following indicates that Panel Lever is Condition Code H:
 - A. Rot or bending/twisting/distortion of the wooden bar.
 - B. Distortion of the fulcrum or bending of the link.Any of the following indicates that Panel Lever is Condition Code G:
 - A. Missing a lifting link or the fulcrum.
2. Look for cracked and broken welds. Panel Lever is Condition Code F if its fulcrum has a cracked or broken weld.

CHORD JACK

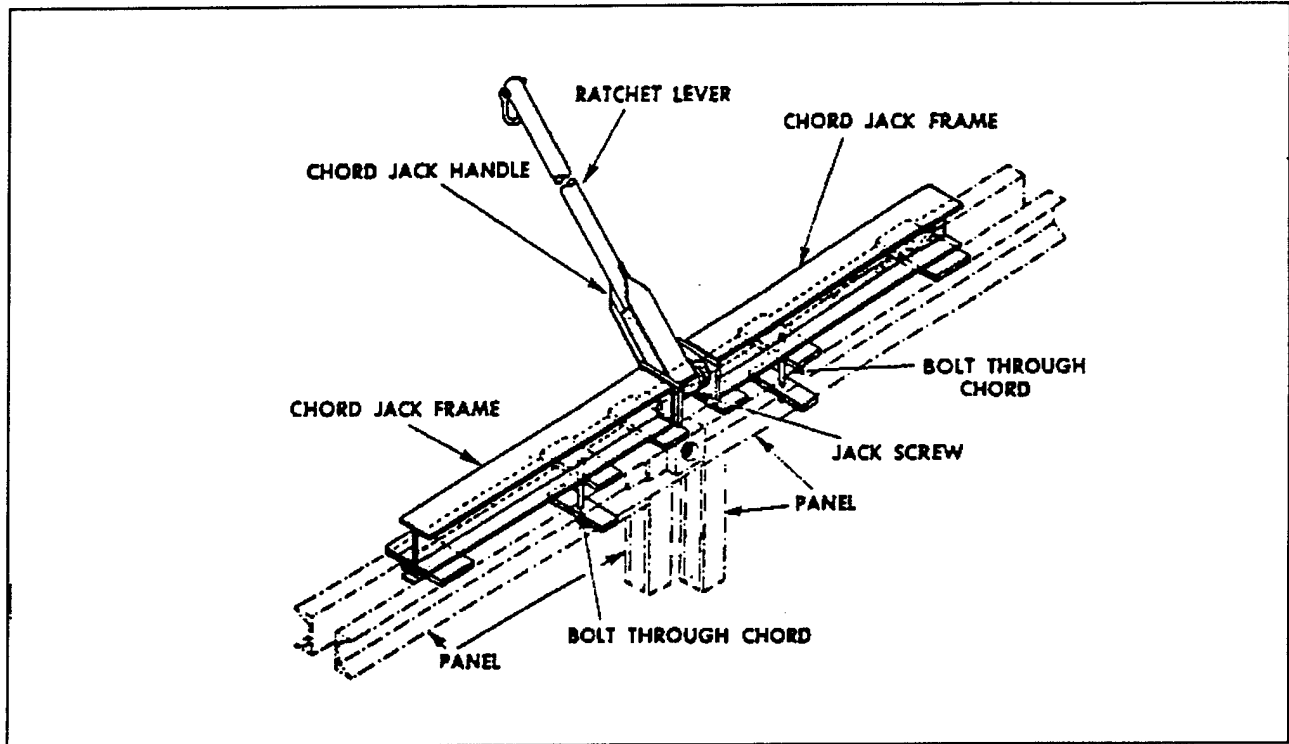

Time Required: 2:00 mins/Chord Jack

Equipment/Personnel Required:

Sufficient personnel necessary to lift, move, and rotate a Chord Jack. Three personnel suggested.

Inspection Procedures:

1. Examine the entire Chord Jack. Any of the following indicates that Chord Jack is Condition Code H:
 - A. Excessive rust/corrosion, visual loss of material from rust/corrosion.
2. Look for any physical damage. Any of the following indicates that Chord Jack is Condition Code H:
 - A. Severe bending/distortion of the steel frames.
 - B. Missing the chord jack handle.
3. Look for cracked and broken welds. Chord Jack is Condition Code F if its steel frames has a such weld.
4. Ensure the Chord Jack can still be operated. Chord Jack is Condition Code F if it does not function properly.
5. Look for missing parts. Any of the following indicates that Chord Jack is Condition Code G:
 - A. Missing the lever or its shackle.

PIN EXTRACTOR

Check for rust/corrosion.
Look for any physical damage.
Check the operation.

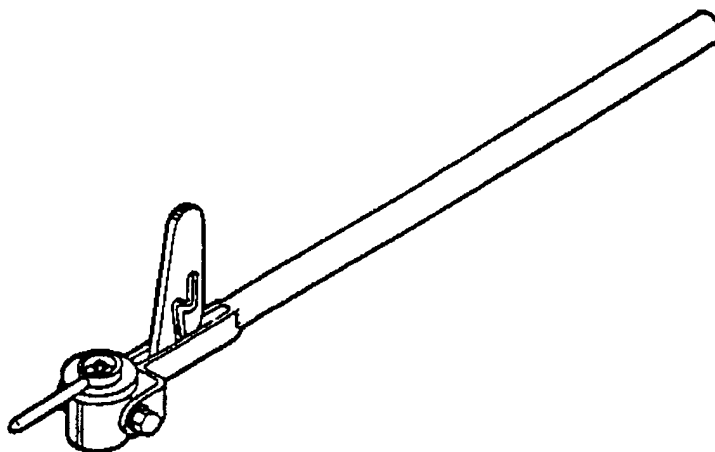

Time Required: 1:00 min/Pin Extractor

Equipment/Personnel Required:

1. One personnel suggested.

Inspection Procedures:

1. Examine the entire Pin Extractor. Any of the following indicates that Pin Extractor is Condition Code H:

A. Excessive rust/corrosion, visual loss of material from rust/corrosion.

2. Look for any physical damage.

Any of the following indicates that Pin Extractor is Condition Code H:

A. Severe distortion which keeps the Pin Extractor from functioning properly.

B. Severely bent extractor handle.

C. Loose/missing/cracked members.

3. Ensure the Pin Extractor can still be operated.

Any of the following indicates that Pin Extractor is Condition Code F:

A. Moderate rust which keeps the Pin Extractor from functioning properly.

B. The Pin Extractor cannot fit over the pin head.

LAUNCHING-NOSE LINK

Check for rust/corrosion.
Look for any physical damage.
Examine all welds.

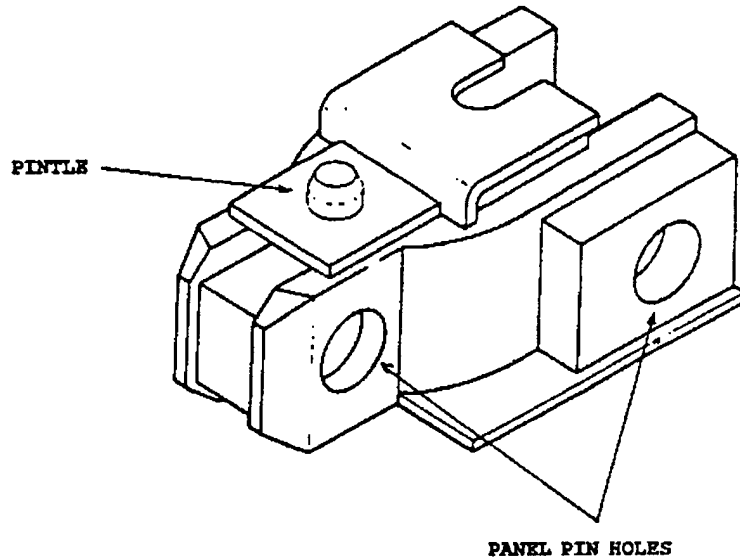

Time Required: 1:00 mins/Launching-Nose Link

Equipment/Personnel Required:

1. One personnel suggested.
2. One clean Panel Pin.

Inspection Procedures:

1. Examine the entire Launching-Nose Link.
Any of the following indicates that Launching-Nose Link is Condition Code H:
A. Excessive rust/corrosion, visual loss of material from rust/corrosion.
Any of the following indicates that Launching-Nose Link is Condition Code F:
A. Rust in the pin holes. If rust is present then ensure a Panel Pin can still be inserted in the pin holes. The Launching-Nose Link is OK if a Panel Pin can be inserted.
2. Look for any physical damage.
Any of the following indicates that Launching-nose link is Condition Code H:
A. Severe distortion of the link.
Any of the following indicates that Launching-nose link is Condition Code F:
A. Missing, cracked, bent pintle.
3. Look for cracked and broken welds. Any such weld indicates that Launching-Nose Link is Condition Code F.

TEMPLATES

Look for rot and warpage.
Look for loose strips/angle cleats.

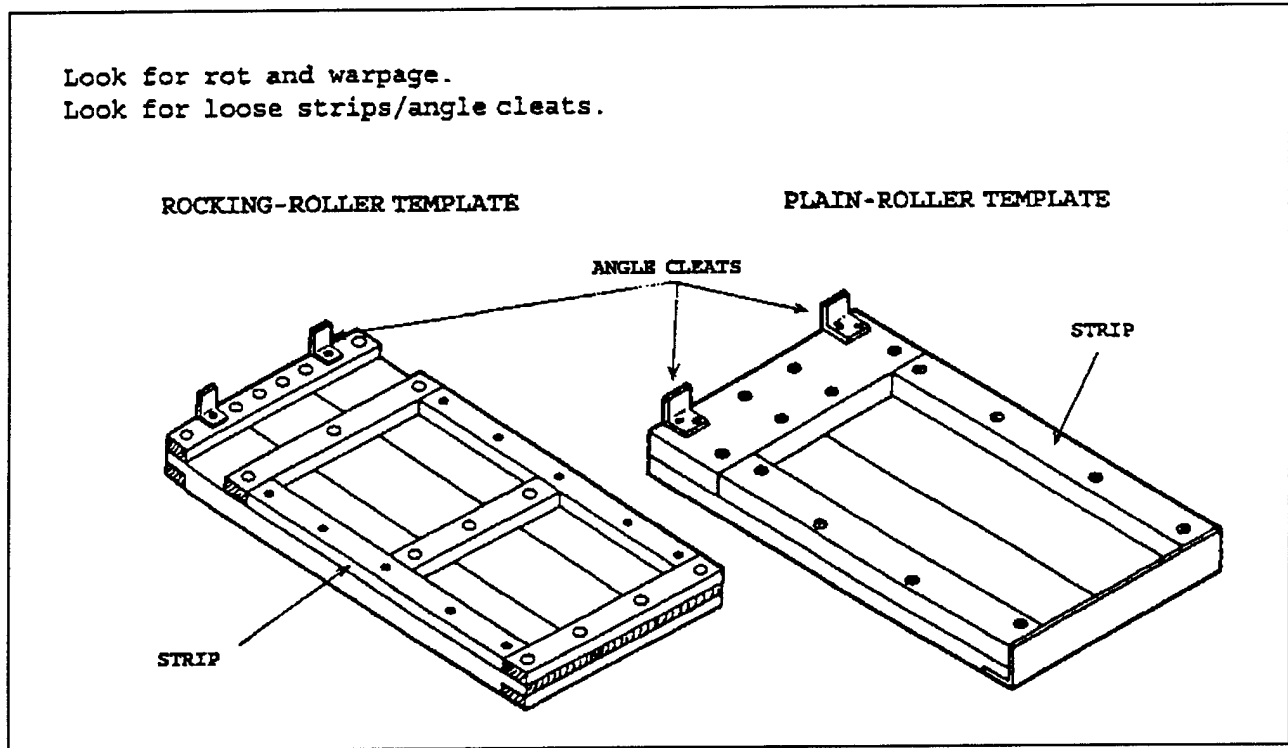

Time Required: 1:00 min/Plain Roller Template and 2:00 mins/Rocking Roller Template

Equipment/Personnel Required:

1. Sufficient personnel and/or equipment necessary to lift, move, and rotate a Template. Three personnel suggested for a Rocking Roller Template and one personnel for a Plain Roller Template.

Inspection Procedures:

1. Examine the entire template. Any of the following indicates that Template is Condition Code H:

- A. Rot of timber.
- B. Warped template.
- C. Loose strips.
- D. Loose angle cleats.

M-2 BAILEY BRIDGE
CONVERSION SET

SPAN JUNCTION POST

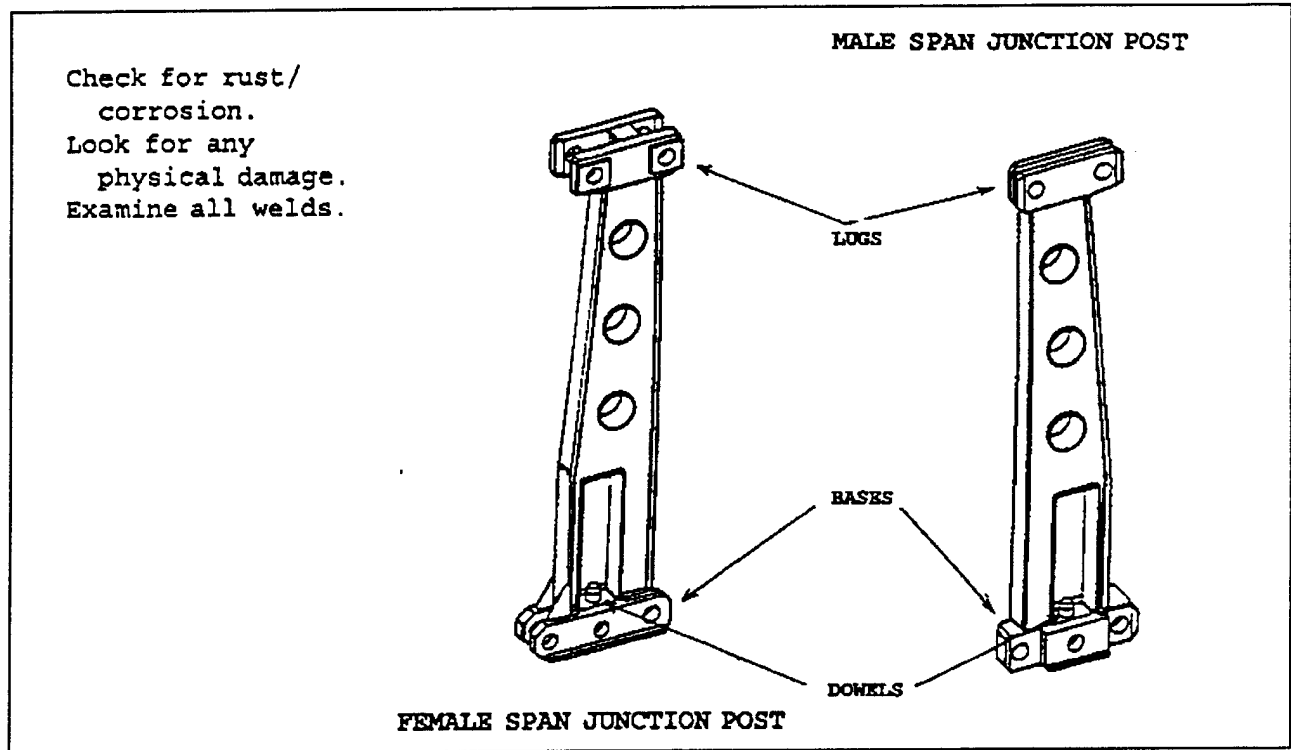

Time Required: 1:00 min/Span Junction Post

Equipment/Personnel Required:

1. Sufficient personnel and/or equipment necessary to lift, move, and rotate a Span Junction Post. Five or six personnel suggested.
2. A clean Panel Pin.

Inspection Procedures:

1. Examine the entire span junction post. Any of the following indicates that Span Junction Post is Condition Code H:

A. Excessive rust/corrosion, visual loss of material from rust/corrosion.

2. Look for any physical damage.

Any of the following indicates that Span Junction Post is Condition Code H:

A. Visual bending of the Post or male and female lugs can no longer receive the panel.

B. Cracked, loosed, or missing dowels or lugs.

Any of the following indicates that Span Junction Post is Condition Code F:

A. A Panel Pin cannot be inserted through any of the lug holes or base holes of the Post.

3. Look for cracked or broken welds. Any such weld indicates that Span Junction Post is Condition Code F.

JUNCTION CHESS

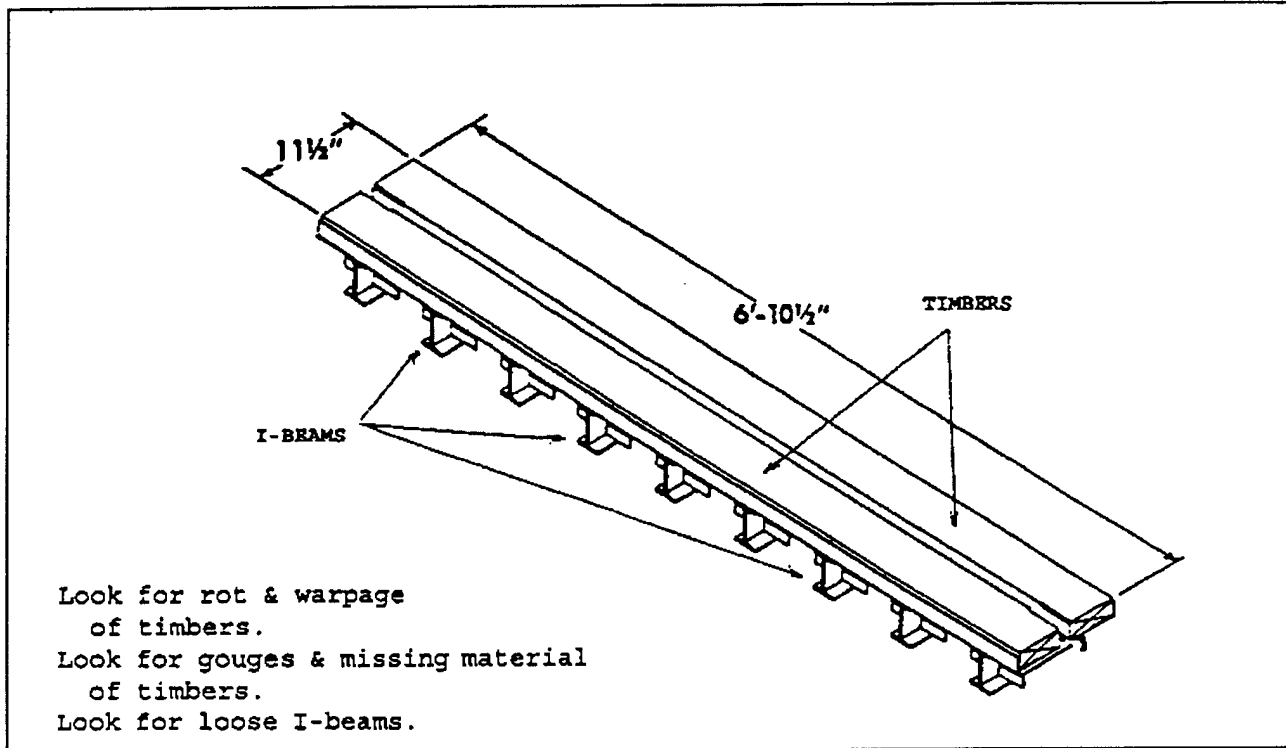

Time Required: 2:00 mins/Junction Chess

Equipment/Personnel Required:

1. Sufficient personnel and/or equipment necessary to lift, move, and rotate a Junction Chess. Four personnel suggested.

Inspection Procedures:

1. Examine the entire junction chess. Any of the following indicates that Junction Chess is Condition Code H:

- A. Excessive rust/corrosion of I-beams, visual loss of material from rust/corrosion of I-beams.
- B. Large gouges or missing material of the timbers.
- C. Rot of timbers.
- D. Excessive warpage of the timbers.
- E. Loose I-beams.

JUNCTION LINK

Check for rust/corrosion.
Look for any physical
damage.

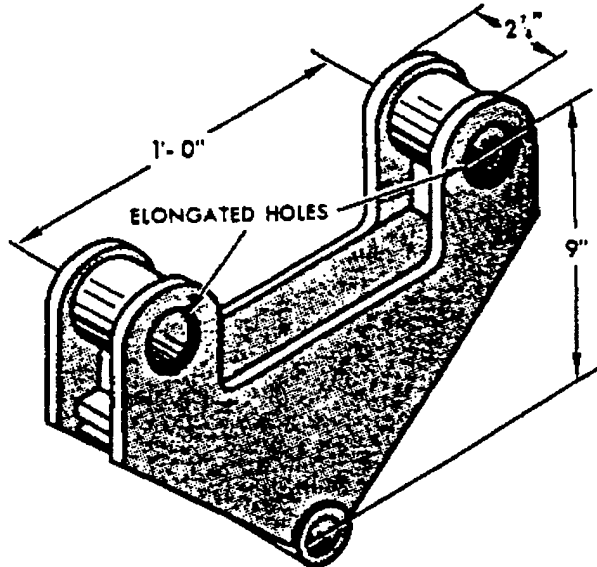

Time Required: 1:00 min/Junction Link

Equipment/Personnel Required:

1. Sufficient personnel necessary to lift and move a Junction Link. Two personnel suggested.
2. A clean Panel Pin.
3. A clean Captive Pin of the Junction-Link Bearing.

Inspection Procedures:

1. Examine the entire junction link. Any of the following indicates that Junction Link is Condition Code H:
 - A. Excessive rust/corrosion, visual loss of material from rust/corrosion.
2. Look for any physical damage.
 - Any of the following indicates that Junction Link is Condition Code H:
 - A. Bending or distortion of the assembly.
 - Any of the following indicates that Junction Link is Condition Code F:
 - A. A Panel Pin cannot be inserted through any of the elongated holes.
 - B. A Captive Pin cannot be inserted into the bottom hole.

JUNCTION-LINK BEARING

Check for rust/corrosion.
Look for any physical damage.
Examine all welds.

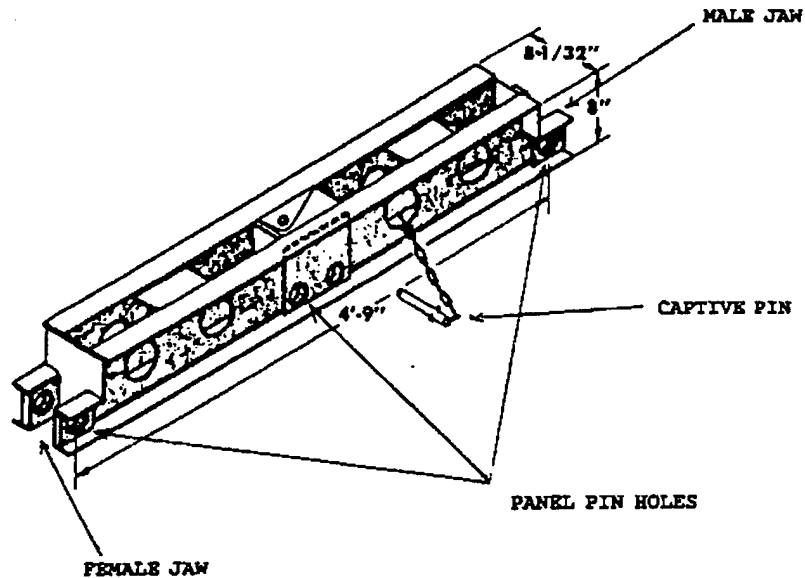

Time Required: 2:00 mins/Junction-Link Bearing

Equipment/Personnel Required:

Sufficient personnel and/or equipment necessary to lift, move, and rotate a Junction-Link Bearing. Five personnel suggested.

Inspection Procedures:

1. Examine the entire junction-link bearing. Any of the following indicates that Junction-Link Bearing is Condition Code H:
 - A. Excessive rust/corrosion, visual loss of material from rust/corrosion.
2. Look for any physical damage.
 - Any of the following indicates that Junction-Link Bearing is Condition Code H:
 - A. Bending or distortion of the Junction-Link Bearing.
 - B. Missing jaws.
 - Any of the following indicates that Junction-Link Bearing is Condition Code F:
 - A. A Panel Pin cannot be inserted through panel-pin holes.
 - B. A Captive Pin cannot be inserted into the hole just above the curved bearing plate.
 - Any of the following indicates that Junction-Link Bearing is Condition Code G:
 - A. Missing captive pin.
3. Look for cracked or broken welds. Any such weld indicates that Junction-Link Bearing is Condition Code F.

CHORD CLAMP

Check for rust/corrosion.
Look for any physical damage.

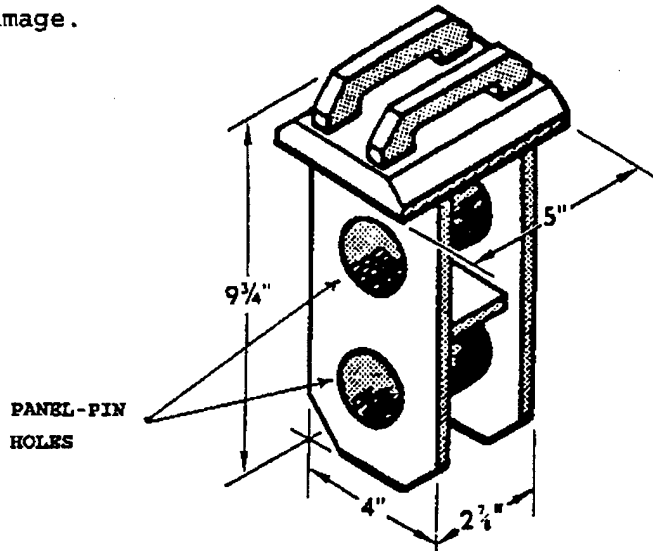

Time Required: 5:00 mins/52 Chord Clamps

Equipment/Personnel Required:

1. One personnel suggested.
2. One clean Panel Pin.

Inspection Procedures:

1. Perform random inspection if the Chord Clamps are stored in containers. Examine the entire chord clamp. Any of the following indicates that Chord Clamp is Condition Code H:

A. Excessive rust/corrosion, visual loss of material from rust/corrosion.

2. Look for any physical damage.

Any of the following indicates that Chord Clamp is Condition Code H:

A. Bending or distortion of the Chord Clamp.

B. Missing members of the Chord Clamp.

Any of the following indicates that Chord Clamp is Condition Code F:

A. A Panel Pin cannot be inserted into any panel-pin hole of the Chord Clamp.

CRIB CAPSILL

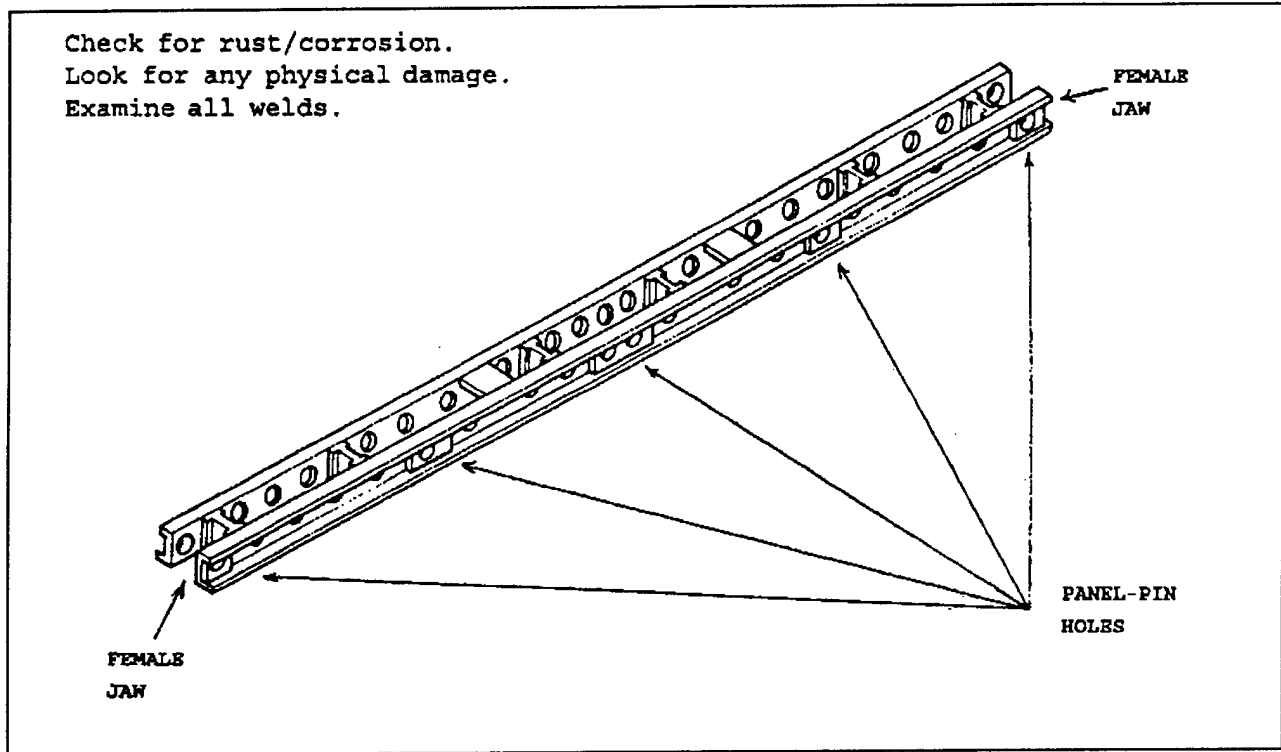

Time Required: 2:00 min/Crib Capsill

Equipment/Personnel Required:

1. Sufficient personnel and/or equipment necessary to lift, move, and rotate a Crib Capsill. Four or five personnel suggested.
2. One clean Panel Pin.

Inspection Procedures:

1. Examine the entire crib capsill. Any of the following indicates that Crib Capsill is Condition Code H:
 - A. Excessive rust/corrosion, visual loss of material from rust/corrosion.
2. Look for any physical damage.

Any of the following indicates that Crib Capsill is Condition Code H:

 - A. Bending/twisting/distortion of the Crib Capsill.

Any of the following indicates that Crib Capsill is Condition Code F:

 - A. A Panel Pin cannot be inserted into any panel-pin hole of the Crib Capsill.
3. Look for cracked or broken welds. Any such weld indicates that Crib Capsill is Condition Code F.

CRIB BEARING

Check for rust/corrosion.
Look for any physical damage.

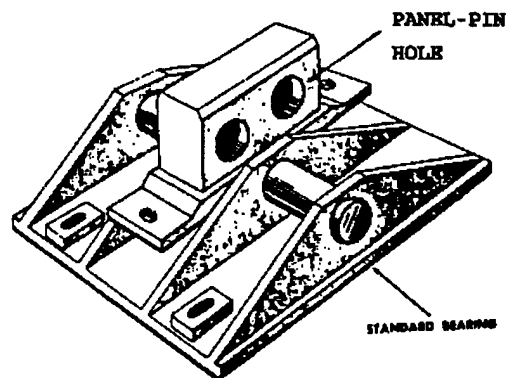

CRIB BEARING
ON A STANDARD BEARING

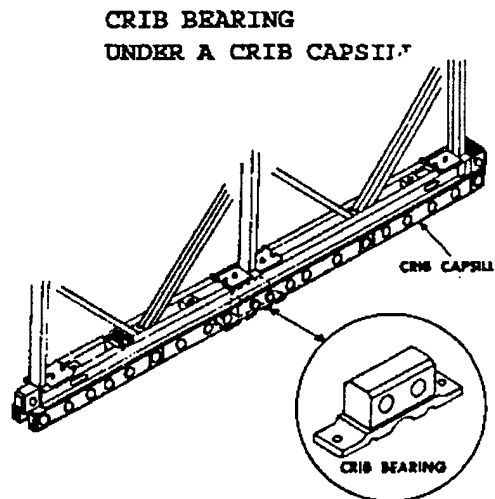

CRIB BEARING
UNDER A CRIB CAPRAIL

Time Required: 2:00 mins/Crib Bearing

Equipment/Personnel Required:

1. Sufficient personnel and/or equipment necessary to lift and move a Crib Bearing. Two personnel suggested.
2. One clean Panel Pin.

Inspection Procedures:

1. Examine the entire crib bearing. Any of the following indicates that Crib Bearing is Condition Code H:

A. Excessive rust/corrosion, visual loss of material from rust/corrosion.

2. Look for any physical damage.

Any of the following indicates that Crib Bearing is Condition Code H:

A. Bending or distortion of the Crib Bearing.

B. Severe warpage on the bottom surface of the Crib Bearing.

Any of the following indicates that the crib bearing is Condition Code

F:

A. A Panel Pin cannot be inserted into any panel-pin hole of the Crib Bearing.

B. The semi-circular bearing of the underside of the block is not smooth.

APPENDIX A

This appendix lists all components of the M-2 Bailey Bridge for the basic set, erection equipment set, and conversion set. The basic set and erection equipment set contain enough components and equipment to install two 80-foot (24.4 meters) double-single (DS) bridges with launching nose or 130-foot (39.0 meters) double-double (DD) bridge with launching nose. The Panel Bridge Engineer Company normally transports one basic set and one erection equipment set of the Bailey bridge on 5-ton dump trucks and 4-ton bolster trailers. The company has two platoons, each capable of transporting one 80-foot (24.4 meters) DS bridge.

APPENDIX A-1

COMPONENTS OF A M-2 BAILEY BRIDGE BASIC SET
(SC 5420-97-E39, NSN 5420-00-530-3784)

NOMENCLATURE	:WT (LBS	:QTY	AUT	: TOT WT	: NOTES
Footwalk Bearer	: 23.00	: 80	: 1,840	:	
Bracing Bolt	: 1.00	: 500	: 500	:	
Chord Bolt	: 7.50	: 200	: 1,500	:	
End-Post Bolt	: 0.75	: 24	: 18	:	
Riband Bolt	: 4.50	: 300	: 1,350	:	
Sway Brace	: 68.00	: 64	: 4,352	:	
Chess	: 65.00	: 370	: 24,050	:	
Transom Clamp	: 7.00	: 300	: 2,100	:	
Aluminum Footwalk	:	:	: 36	:	
Wood Footwalk	: 104.00	: 36	: 3,744	:	Not included in Supply Catalog
Bracing Frame	: 44.00	: 50	: 2,000	:	
Hexagon Plain Nut	:	: 24	:	:	
Panel (Truss)	: 577.00	: 126	: 72,702	:	
Ramp Pedestal	: 93.00	: 16	: 1,488	:	
Steel Picket	: 12.00	: 40	: 480	:	
Panel Pin	: 6.10	: 300	: 1,830	:	
Short Panel Pin	: 5.80	: 25	: 145	:	
Sway-Brace Pin	: 1.10	: 50	: 55	:	
Base Plate	: 381.00	: 8	: 3,048	:	
Tie Plate	: 3.50	: 25	: 88	:	
Female End Post	: 130.00	: 12	: 1,560	:	
Male End Post	: 121.00	: 12	: 1,452	:	
Footwalk Post	: 10.00	: 80	: 800	:	
Raker	: 22.00	: 64	: 1,048	:	
Button Ramp	: 348.00	: 16	: 5,568	:	
Plain Ramp	: 338.00	: 32	: 10,816	:	
Pin Retainer	: 0.13	: 1,000	: 130	:	
Riband	: 162.00	: 48	: 7,776	:	
Fibrous Rope	: 160.00	: 1	: 160	:	
Hexagon Cap Screw	:	: 24	:	:	
Bearing Shoe	: 68.00	: 16	: 1,088	:	
Button Stringer	: 267.00	: 36	: 9,612	:	
Plain Stringer	: 260.00	: 72	: 18,720	:	
Transom	: 618.00	: 56	: 34,608	:	
Parts & Tools Bag	:	: 20	:	:	

APPENDIX A-2

COMPONENTS OF A M-2 BAILEY BRIDGE
ERECTION EQUIPMENT SET
(SC 5420-97-E40, NSN 5400-00-530-3785)

NOMENCLATURE	:WT (LBS):	QTY	AUT	: TOT WT	: NOTES
Carrying Bar (42" long)	: 8.00	: 14	:	112	:
Double Block (3/4" rope)	: 8.00	: 8	:	64	:
Triple Block (1" rope)	: 20.00	: 4	:	80	:
Snatch Block (3/4" rope)	: 6.30	: 4	:	25	:
Pin Extractor (~40" long)	: 18.00	: 4	:	72	:
Double-Face Hand Hammer	: 8.00	: 12	:	96	:
Carpenter Hammer (Curved Claw	: 1.00	: 1	:	1	:
Socket Wrench Handle, Steel	:	: 10	:	:	:
Reversible	:	:	:	:	:
Holdfast w/ 9 pickets	: 160.00	: 12	:	1,920	:
Chord Jack	: 82.00	: 6	:	492	:
Rack Bar Jack, 15-ton	: 128.00	: 10	:	1,280	:
Panel Lever	: 48.00	: 6	:	288	:
Launching Nose Link	: 28.00	: 24	:	672	:
Softwood Lumber, Dimension	: 18.00	: 324	:	5,832	:
Softwood Lumber, Timber	: 52.00	: 194	:	10,088	:
Rubber Mallet	:	: 10	:	:	:
Steel Nail, 50lb/Box	: 50.00	: 6	:	300	:
Common Nail, Box	:	: 20	:	:	:
Plain Roller	: 116.00	: 12	:	1,392	:
Rocking Roller	: 206.00	: 12	:	2,472	:
Guide Roller Assembly	:	: 6	:	:	:
Transom Roller	: 12.00	: 4	:	48	:
Rope, 3" Circular	: 325.00	: 1	:	325	:
Rope, 2 1/4" Circular	: 100.00	: 1	:	100	:
Rope, 2" Circular	: 160.00	: 3	:	480	:
Shackle, Anchor-Type	: 5.00	: 4	:	20	:
Jack Shoe	: 36.00	: 8	:	288	:
Sling & Wire Rope Assembly	:	: 4	:	:	:
Socket, 1 1/8", 12 PT	:	: 10	:	:	:
Socket, 1 7/8", 12 PT	:	: 10	:	:	:
Steel Anchor Stake	: 12.00	: 18	:	216	:
Rocking Roller Template	: 78.00	: 12	:	936	:
Plain Roller Template	: 22.00	: 12	:	264	:
Carrying Tong	: 13.00	: 20	:	260	:
Wood Wedge	: 12.00	: 32	:	384	:
Wire Rope Assembly	: 12.00	: 4	:	48	:
Box Wrench, 3/4", 12 PT	:	: 4	:	:	:
Open End Wrench, 1 1/8"	:	: 10	:	:	:
Open End Wrench, 1 1/2"	:	: 10	:	:	:
Open End Wrench, 1 7/8"	:	: 10	:	:	:
Single Socket Wrench, 1 1/8"	:	: 20	:	:	:

APPENDIX A-3

COMPONENTS OF A M-2 BAILEY BRIDGE CONVERSION SET
(SC 5420-97-E29, NSN 5420-00-267-0026)

NOMENCLATURE	:WT (LBS):	QTY	AUT :	TOT WT :	NOTES
Transport Bag	: 2.00 :	30 :		60 :	
Crib Bearing	: 37.00 :	24 :		888 :	
Junction-Link Bearing	: 217.00 :	6 :		1,302 :	
Bracing Bolt	: 1.00 :	36 :		36 :	
Chord Bolt	: 7.50 :	28 :		210 :	
Sway Brace	: 68.00 :	12 :		816 :	
Crib Capsill	: 251.00 :	12 :		3,012 :	
Junction Chess	: 149.00 :	4 :		596 :	
Chord Clamp	: 11.00 :	52 :		572 :	
Transom Clamp	: 7.00 :	44 :		308 :	
Bracing Frame	: 44.00 :	9 :		396 :	
Junction Link	: 36.00 :	6 :		216 :	
Launching-Nose Link	: 28.00 :	6 :		168 :	
Panel Pin	: 6.10 :	160 :		976 :	
Sway Brace Pin	: 1.10 :	2 :		2 :	
Tie Plate	: 3.50 :	16 :		56 :	
Female Span Junction Post	: 202.00 :	6 :		1,212 :	
Male Span Junction Post	: 194.00 :	6 :		1,164 :	
Raker	: 22.00 :	16 :		352 :	
Panel Pin Retainer	: 0.13 :	200 :		26 :	

APPENDIX B

BAILEY BRIDGE COMPONENT DESCRIPTION

APPENDIX B-1

M-2 BAILEY BRIDGE COMPONENT DESCRIPTION BASIC SET

01. Panel

(a) The panel is the basic member of the bridge. It is a welded high tensile steel truss section 10 feet long (3.0 meters), 5 feet 1 inch (1.5 meters) high, and 6 1/2 inches (16.5 centimeters) wide. It weighs 577 pounds (262 kilograms) and can be carried by six soldiers using carrying bars.

(b) The horizontal members of the panel are called chords. Both chords have male lugs at one end and female lugs at the other. Panels are joined end to end by engaging these lugs and placing panel pins through the holes in the lugs. On top of the bottom chord are four seatings or dowels. The beams that support the bridge roadway will be clamped to these dowels..

02. Transom

(a) The transom supports the floor system of the bridge. It is 10 inches (25.4 centimeters) by 19 feet 11 inches (6.1 meters) long. It has a 4 1/2-inch (11.4 centimeters) flange and a 5/6-inch (0.8 centimeter) cover plate on each flange. It weighs 618 pounds (280 kilograms) and can be carried by eight soldiers using carrying tongs clamped to the upper flange or carrying bars inserted through holes in the web.

(b) The under side of the transom has six holes into which the panel dowels fit. The transom rests on the lower chord of the panel and is held in place with a transom clamp. The upper side of the transom has six lugs with an additional lug near each. The stringers and rakers attach to these lug.

(c) Transoms are normally spaced 5 feet (1.5 meters) apart, one at the middle and one at the end of each panel, to support vehicles of Military Load Class (MLC) 70 or less. Four transoms per bay - two in the middle and one at each end of the panel - are required to support vehicles of MLC over 70.

03. Sway Brace

The sway brace is a 1 1/8-inch (2.9 centimeter) steel rod, hinged at the center, and adjusted by a turnbuckle. It weighs 68 pounds (30.8 kilograms). At each end is an eye, and a chain with a pin attached. This pin is inserted through the eye to the sway brace to the panel. The sway brace is given the proper tension by inserting the tail of an erection wrench in the turnbuckle and screwing it tight. The locknut is then screwed up against the turnbuckle.

Two sway braces are required in the lower chord of each bay of the bridge, except the first bay of the launching nose, and in each bay of overhead bracing.

04. Stringer

Stringers carry the roadway of the bridge. Each stringer consists of three 4-inch (10.2 centimeters) steel beam, 10 feet (3.0 meters) long, joined by welded braces. There are two types of stringers: plain stringers weighing 260 pounds (118 kilograms) and button stringers weighing 267 pounds (122 kilograms). They are identical except that the latter has 12 buttons which hold the ends of the chess in place. Each bay of bridge has six stringers: four plain stringers in the middle, and a button stringer on each side. The stringers are positioned by the lugs on top of the transoms.

05. Chess

Chess, often referred to as deck or decking, form the road surface. A

piece of chess is 2 inches (5.1 centimeters) by 8 3/4 inches (22.2 centimeters) by 13 feet 10 inches (4.2 meters). It is made of wood and weighs 65 pounds (29.5 kilograms). It is notched at the ends to fit between the buttons of the button stringer. Each bay of bridge contains 13 chess, which lie across the stringers and are held in place by the buttons on the stringers. Chess are held down by ribands.

06. Riband

A riband is a metal curb 8 inches (20.3 centimeters) high and 10 feet long (3.0 meters). It weighs 162 pounds (73.5 kilograms). It is fastened to the button stringers by four J-type riband bolts.

07. Raker

The raker is a 3-inch (7.6 centimeters) steel beam with a 2 3/8-inch (6.0 centimeters) flange. It is 3 feet 8 5/16 inches (1.1 meters) long and weighs 22 pounds (10.0 kilograms). A raker connects the ends of the transom to the top of one end of each panel of the inner truss. This prevents the panels from overturning. An additional raker is used at each end of the bridge. Both ends of the raker have hollow dowels for the bracing bolts. The dowels fit through a hole in the panel and a hole in the transom.

08. Bracing Frame

The bracing frame is a rectangular frame, 4 feet 3 inches (1.3 meters) by one foot 8 inches (50.8 centimeters), with a hollow conical dowel in each corner. It weighs 44 pounds (20.0 kilograms). The bracing frame is used to brace the inner two trusses on each side of the double- and triple-truss bridge. Bracing bolts attach the bracing frames horizontally to the top chords of the bridge and vertically on one end of each panel in the second and third stories.

09. Bearing (Bearing Shoe)

The bearing spreads the load of the bridge to the base plate. A bearing is a welded steel assembly containing a round bar which, when the bridge is completed, supports the bearing blocks of the end posts. During assembly of the bridge, it supports the bearing block of the rocking roller. The bar is divided into three parts by two intermediate sections that act as stiffeners.

The bearing is 4 5/16 inches (11.9 centimeters) high and weighs 68 pounds (30.8 kilograms). One bearing is used at each corner of a single-truss bridge and two bearings per corner for a double- or triple-truss bridge.

10. End Post

End posts are used on both ends of each truss of the bridge to take the vertical shear. They are placed only on the story carrying the decking. They are 5-foot 8-inch (1.7 meters) columns made of two 4-inch (10.1 centimeters) channels and plates welded together. There are two types, male and female, having male and female lugs, respectively. These lugs are secured to the end panels of the bridge by panel pins through holes in the lugs. The male and female end posts weigh 121 and 130 pounds (54.9 and 59.0 kilograms), respectively. End posts have a step to support a transom outside the panel at one end of the bridge. In jacking the bridge, the jack is placed under the step. The lower end of the end post has a bearing block with a semicircular groove which fits over the bearing.

11. Ramp

Ramps are similar to stringers, but consist of three 5-inch (12.7 centimeters), instead of 4-inch (10.2 centimeters), steel beams. They are 10 feet (3.0 meters) long and are joined by welded braces. The lower surface of the ramp tapers upward near the ends. There are two types of ramps: plain

ramps weighing 338 pounds (153 kilograms), and button ramps weighing 349 pounds (158 kilograms). They are identical except the latter has 12 buttons which hold the ends of the chess in place. The ends of the ramps fit into lugs on the transoms at the ends of the bridge.

12. Footwalk

The footwalk may be of wood or aluminum. The wood footwalks are 2 feet 6 inches (0.8 meter) wide and 10 feet (3.0 meters) long and weighs 104 pounds (229 kilograms). The aluminum footwalks are 25 3/4 inches (65.4 centimeters) wide and 9 feet 11 1/2 inches (3.0 meters) long. Supported on footwalk bearers, footwalks are laid along the outer sides of the bridge for use by foot troops.

13. Footwalk Post

A footwalk post is 4 feet (1.2 meters) high and weighing 10 pounds (4.5 kilograms) is fitted into every footwalk bearer. Hand ropes are threaded through two eyes on each post and secured either to holdfasts on the banks or the end footwalk posts.

14. Footwalk Bearer

A footwalk bearer is a built-up beam of pressed steel 4 feet (1.2 meters) long, weighing 23 pounds (10.4 kilograms). Bearers are attached to all transoms and holds the footwalk post.

15. Transom Clamp

The transom clamp is a hinged screw-in type clamp, 13 1/2 inches (34.3 centimeters) high and 8 inches (20.3 centimeters) across the top. It weighs 7 pounds (3.2 kilograms). It clamps the transom to the vertical and bottom chord of the panel. It is tightened by a vise-handled screw.

16. Ramp Pedestal

Ramp pedestals are built-up welded steel assemblies weighing 93 pounds (42 kilograms). They prevent the transoms supporting multiple-length ramps from overturning and spread the transom load over the ground. They are held in place by spikes or pickets driven through holes in their base plates.

17. Base Plate

The base plate is a welded steel assembly with built-up sides and lifting-hook eyes on the top at each corner. It is used under the bearings to spread the load from the bearings over the ground or grillage. The bottom surface of the base plate is 13 1/2 square feet (1.25 square meters). The base plate weighs 381 pounds (173 kilograms) and is large enough for the bearings at one corner of a single-, double-, or triple-truss bridge. Bearings can slide 9 inches (22.9 centimeters) longitudinally on the base plate. The number 1, 2, and 3 are embossed on the edges of the base plate to indicate the position of the plate under the inner truss of single-, double-, and triple-truss bridges respectively.

18. Overhead Bracing Support

The overhead bracing support is used to clamp overhead transoms and sway braces to trusses for overhead bracing of triple-story bridges. The support is a welded metal assembly that weighs 150 pounds (68 kilograms). It is fastened to the tops of third story panels by chord bolts. A transom is seated over the pintles on top of the support and secured by cleats over the lower flange held by 4 nuts and bolts. One support per girder is placed on each bay of bridge.

19. Panel Pin

The panel pin is 8 5/16 inches (21.1 centimeters) long, 1 7/8 inches (4.8 centimeters) in diameter, and weighs 6 pounds (2.7 kilograms). It has a

tapered end with a small hole for a retainer clip. A groove is cut across the head of the panel pin parallel to the bridge pin retainer hole. Panel pins should be inserted with the groove horizontal; otherwise, the flanges of the panel chord channels make it difficult to insert the retainer clip.

20. Short Panel Pin

The short panel pin is $\frac{3}{4}$ inch (1.9 centimeters) shorter than the normal panel pin and weighs 5.8 pounds (2.6 kilograms). It is used to pin the end posts of the outer and middle trusses in a triple-truss bridge.

21. Tie Plate

A tie plate is a piece of flat steel $2\frac{1}{2}$ by $\frac{3}{8}$ by 12 inches (6.4 by 1.0 by 30.5 centimeters) weighing $3\frac{1}{2}$ pounds (1.6 kilograms). It has a hollow conical dowel at each end. The tie plate is used only in triple-truss bridges. It secures the second truss to the third truss, using the unoccupied raker holes in the panels at each joint and at the ends of the bridge.

22. Bracing Bolt

A bracing bolt is $\frac{3}{4}$ inch (1.9 centimeters) in diameter, $3\frac{1}{2}$ inches (8.9 centimeters) long, and weighs about 1 pound (0.5 kilograms). A special lug on each head prevents rotation when the bolt is tightened. A $1\frac{1}{8}$ -inch (2.9 centimeters) wrench is used to tighten it. The bracing bolt is used to attach rakers, bracing frames, and the tie plates to panels. It is inserted into the hollow dowels of the braces to draw parts into proper alignment.

23. Chord Bolt

A chord bolt is $1\frac{3}{4}$ inches (4.4 centimeters) in diameter, $10\frac{1}{2}$ inches (26.7 centimeters) long, and weighs $7\frac{1}{2}$ pounds (3.4 kilograms). It is tapered through half its length to assist in drawing the panels into alignment. A $1\frac{7}{8}$ -inch (4.8 centimeters) wrench is used to tighten it. Chord bolts join the panels, one above the other, to form double- and triple-story bridges. Two bolts per panel pass upward through holes in the panel chords and are tightened with nuts on the lower chord of the upper story. They are also used to fasten overhead bracing supports to the top panel chord.

24. Riband Bolt

A riband bolt is a J-type bolt 1 inch (2.5 centimeters) in diameter and $8\frac{5}{8}$ inches (21.9 centimeters) long. It weighs $4\frac{1}{2}$ pounds (2.0 kilograms). A $1\frac{1}{2}$ -inch (3.8 centimeters) wrench is used to tighten it. The riband bolt fastens the riband to the button stringers and ramps. The hook end of the bolt grips the lower flange of the outer beam of the button stringer or ramp.

APPENDIX B-2

M-2 BAILEY BRIDGE COMPONENT DESCRIPTION ERECTION EQUIPMENT SET

01. Rocking Roller

The rocking roller consists of three rollers housed in a balanced arm which fits over the bearing, and is free to rock on it. The side rollers can be removed from the flanges by removing split pins from spindles underneath the flange; they then remain loosely attached to the frame by a chain. The rollers are used for trusses and distribute the bridge load along the bottom chord during launching.

02. Plain Roller

The plain roller consists of a welded housing containing a single roller split in two. Trusses can be carried on either half of the roller for single-truss bridges or on both halves for double- and triple-truss bridges.

03. Transom Roller

The transom roller consists of a roller which is fitted with bronze bushings at each end and revolves on a 1-inch diameter steel pin mounted in a steel frame. The roller is used to make the placement and removal of transoms easier during the assembly and disassembly of the bridge.

04. Jack & Jack Shoe

The jack used to lift the bridge on and off the rocking rollers is a mechanical lifting jack of the type normally used in rigging and construction work. The jack shoe is a welded assembly which fits over the bearing and on the base plate to support the jack.

05. Panel Lever

The panel lever is used to assemble the second and third trusses after the first truss is in place over the gap. It consists of a wooden bar, a fulcrum near the center, and a lifting link at the end of the bar.

06. Chord Jack

The chord jack consists of two welded steel frames which fit on the top chord and engage with the plates which carry the holes for bracing frame dowels. Each frame is held down by a bolt through the chord and the frame. A knuckle-threaded screw assembly fits between the frames and is operated by a ratchet lever to force them apart. The ratchet lever has a shackle at its end to which a rope can be attached to facilitate operation. The chord jack is used to spread the upper jaws of the second-story panels and allow the upper panel pins to be inserted.

07. Pin Extractor

The pin extractor assists in dismantling the bridge. After the pin has been driven part way out, and the recess under the head of the pin is exposed, the pin extractor grips the pin head and forces the pin out by a levering action.

08. Launching-Link Nose

The launching-nose link MK II consists of two steel frames welded back to back. The lugs of two panels fit into the link. The sides of the link have holes into which panel pins can be inserted. The links lie with the underside

of the bottom chords and have a false flange welded on the bottom edge so that the bridge can be rolled out on launching rollers. It also has a pintle on the top to seat a transom. Launching-nose links overcome the sag occurring when the launching-nose is cantilevered over the gap.

09. **Template**

Two types of templates are provided, one to locate the bearings for the rocking rollers and the other for the plain rollers. The rocking roller template consists of a timber base with timber strips on top forming two spaces large enough for rocking roller bearings. The plain roller template consists of a timber base with timber strips on three sides and a steel strip on the fourth. The strips surround a space large enough for the base of a single plain roller. At one end of both types of templates are two angle cleats which are used as measuring points.

APPENDIX B-3

M-2 BAILEY BRIDGE COMPONENT DESCRIPTION CONVERSION SET

01. Span Junction Post

Male and female span junction posts are used in place of the standard end posts for connecting adjacent ends of two spans and supporting them on the same bearing. The male and female junction posts have lugs that are pinned to female and male ends, respectively, of standard panels. At the junction, each post has two other connecting lugs, a male and female lug at the top according to type, and a universal jaw at the base. Irrespective of type, two posts can be connected at the base by a normal panel pin.

02. Junction Chess

The junction chess is used to span the gap in the bridge floor between the ends of the two spans connected by span junction posts. Four junction chess are used for each span junction. The junction chess consists of two 6-foot 10 1/2-inch timbers fastened to nine steel I-beams 11 1/2 inches long.

03. Junction Link

The junction link transfers the end reaction from two span junction posts to a junction link bearing. The junction link is a triangular-shaped steel assembly with two projected male lugs on each top side spaced to pin with panel pins to the two-span junction posts. Both holes are elongated to permit some play in the joint. The bottom of the junction link tapers down to a nose with a tubular bearing which seats on the curved bearing plate of the junction-link bearing and is held in place by a captive pin on the junction-link bearing.

04. Junction-Link Bearing

The junction-link bearing is used under the junction link which support the ends of the bridge. It is made of two 8-inch channels welded back to back with the same spacing as between channels in the chords of the panel. It is 5 feet 1 inch long and has female jaws at each end. There is a panel-pin holes on each jaw. Between the webs of the channels in the center of the junction link bearing is a curved bearing plate on which the junction link bears. There is a hole through the webs of the channels just above the curved bearing plate for a captive pin which locks the junction link in place. There are two panel-pin holes in the webs of the channels beneath the curved bearing plate.

They are used to pin the crib bearing which fits in the recess between the channels.

05. Chord Clamp

The chord clamp is used to pin (a) crib capsill to panel chord, (b) crib capsill to female jaw of panel, (c) crib capsill to junction-link bearing, and (d) junction-link bearing to female jaw of panel. The chord clamp is in effect a double-length male lug with two panel-pin holes and a T-head. The clamp is slipped between the chord channels of a panel until the head bears on the channel flanges, then the clamp is pinned to a crib capsill or other female joint with a panel pin. If the chord clamp is slipped through two adjacent female jaws, it is pinned to each by panel pins through both holes in the chord clamp.

06. Crib Capsill

The crib capsill distributes the load from the bridge to the main chords of vertical panels or to the three verticals of horizontal panels in a crib. The crib capsill is made of two 4-inch channels welded back to back to spacer lugs with the same spacing between channels as in the chord of the standard panel. It is 10 feet 2 inches long, and has female jaws at each end. Holes are spaced along the webs of the channels. Six pairs of panel-pin holes are reinforced with steel blocks and spaced so male lugs of two adjacent panels or of a single panel can be connected to the crib capsill with panel pins.

07. Crib Bearing

The crib bearing is used as a base of panel cribs and can be pinned with a panel pin to the following: (a) one female jaw of a vertical panel; (b) two female jaws of adjacent vertical panels; (c) two central holes of a crib capsill; two central holes of a junction-link bearing. The crib bearing can be spiked to a timber sill or set on a standard bearing. The crib bearing is a double-length male lug welded horizontally to a base block. One of the pin hole is elongated to make pinning easier when both holes are used. If only one hole is needed, the round one is used. Holes are provided in the base block of the crib bearing for spiking to a timber sill. The underside of the base block has a semi-circular bearing to seat on a standard bearing.