

| REPORT DOCUMENTATION PAGE | | | Form Approved OMB No. 0704-0188 | |
|--|---|--|------------------------------------|----------------|
| Public reporting burden for this collection of information is estimated to average 1 hour per response, including the time for reviewing instructions, searching existing data sources, gathering and maintaining the data needed, and completing and reviewing the collection of information. Send comments regarding this burden estimate or any other aspect of this collection of information, including suggestions for reducing this burden, to Washington Headquarters Services, Directorate for Information Operations and Reports, 1215 Jefferson Davis Highway, Suite 1204, Arlington, VA 22202-4302, and to the Office of Management and Budget, Paperwork Reduction Project (0704-0188), Washington, DC 20503. | | | | |
| 1. AGENCY USE ONLY (Leave blank) | 2. REPORT DATE 1996 | 3. REPORT TYPE AND DATES COVERED Final 1 Jun 93 - 31 May 96 | | |
| 4. TITLE AND SUBTITLE Nonlinear Dynamics of Quasi-Optical Device Arrays | | 5. FUNDING NUMBERS DAAH04-93-G-0210 | | |
| 6. AUTHOR(S) Robert A. York | | | | |
| 7. PERFORMING ORGANIZATION NAME(S) AND ADDRESS(ES) Dept. of Electrical & Computer Engineering University of California Santa Barbara, CA 93106 | | 8. PERFORMING ORGANIZATION REPORT NUMBER | | |
| 9. SPONSORING/MONITORING AGENCY NAME(S) AND ADDRESS(ES) U.S. Army Research Office P.O. Box 12211 Research Triangle Park, NC 27709-2211 Attn: Patsy S. Ashe/Grants Officer | | 10. SPONSORING/MONITORING AGENCY REPORT NUMBER ARO 30853.17-EL-41P | | |
| 11. SUPPLEMENTARY NOTES The view, opinions and/or findings contained in this report are those of the author(s) and should not be construed as an official Department of the Army position, policy, or decision, unless so designated by other documentation. | | | | |
| 12a. DISTRIBUTION/AVAILABILITY STATEMENT Approved for public release; distribution unlimited. | | 12b. DISTRIBUTION CODE | | |
| 13. ABSTRACT (Maximum 200 words) This project involved an exploration of mutual synchronization phenomenon in coupled-oscillator systems. The systems under study were comprised of microwave or millimeter-wave oscillators arranged in a one or two-dimensional array. Each oscillator delivers its power to a planar antenna structure so that the power is collected and combined radiatively, or "quasi-optically." The oscillators are coupled together either through radiative interactions between the antennas, or through dedicated transmission-line circuits. Such systems can be used for coherent power combining of solid-state sources. | | | | |
| 14. SUBJECT TERMS Oscillators, synchronization, beam scanning, nonlinear dynamics, noise | | 15. NUMBER OF PAGES 17 | | 16. PRICE CODE |
| 17. SECURITY CLASSIFICATION OF REPORT UNCLASSIFIED | 18. SECURITY CLASSIFICATION OF THIS PAGE UNCLASSIFIED | 19. SECURITY CLASSIFICATION OF ABSTRACT UNCLASSIFIED | 20. LIMITATION OF ABSTRACT UL | |

19970321 018

DTIC QUALITY INSPECTED 2

BRIEF OUTLINE OF RESEARCH FINDINGS

Specific Aims — The goals of our work have not changed from the original proposal.

Summary Results — The principle achievement during this reporting period was the demonstration of a high-power two-dimensional coupled oscillator array at X-band, which produced approximately 12 Watts of RF power using twelve oscillators arranged in a 2×6 array. In addition, exploratory work in chaotic dynamics of coupled-oscillator systems was initiated, and low-dimensional chaos was identified in small chains of coupled oscillators both theoretically and experimentally.

High Power Array: For power-combining purposes, our best result using the coupled-oscillator concept has been a 6×2 array operating at 11 GHz. This array used a transmission-line coupling network similar to previously reported arrays in this program, with two linear arrays of six oscillators interconnected at the edges to form a 12-element loop. The oscillators were designed around packaged GaAs power FETs (NEC 9008-11) in a feedback oscillator topology. Since this was a power design, care was taken to provide adequate heatsinking for the device. Consequently a "tray" approach was adopted as illustrated in figure 1, where each oscillator circuit was constructed on a Duroid substrate with a thick (quarter inch) Aluminum ground plane. Each oscillator fed a patch antenna on a separate board via short coaxial feed-throughs. The feed point on the probe-fed patches was selected to provide an optimal impedance match for maximum output power, which was determined empirically using a mechanical tuner and network analyzer. Each oscillator produced approximately 1 Watt in this configuration, under typical bias conditions of 8.5 V @ 900 mA.

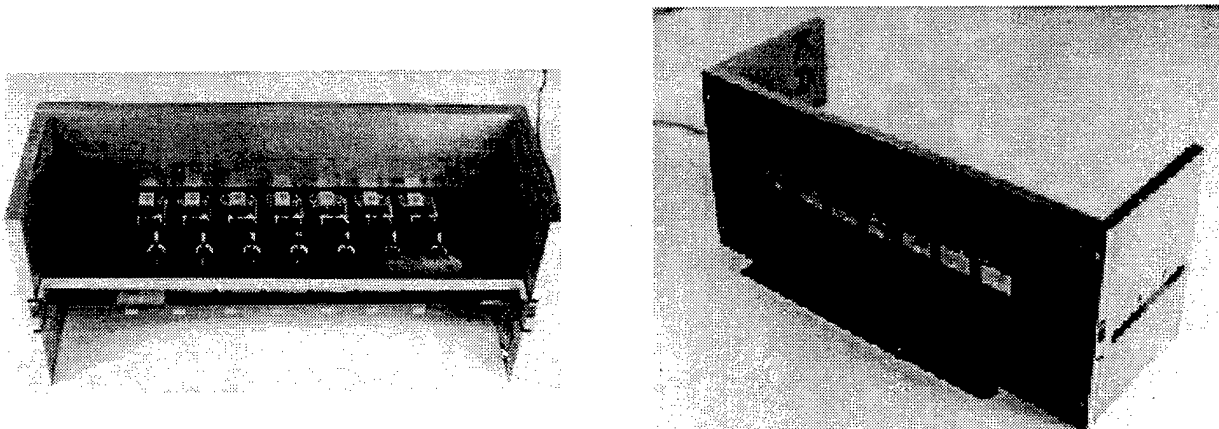

Figure 1 — Photograph of an 11 GHz power-oscillator array palette (rear-view and front-view) producing 6 Watts. The measured radiation pattern showing in-phase operation is given in fig. 2. The oscillators are to connected to a patch array on the front board using coaxial feed-throughs.

The array was built from two linear array oscillator "palettes", one of which is shown in figure 1. The measured H-plane pattern for the 6×2 array is shown in figure 2. The measured Effective Isotropic Radiated Power (EIRP) for this array was 933 Watts. The E-plane patterns were distorted by the presence of additional parasitic patches on one side of the array (the array was actually a sub-array of a larger 6×6 version. Since the E-plane pattern for this array does not closely match the theoretical pattern for a twelve element patch array, the total power could not be reliably estimated by finding the theoretical directivity for the array. An empirical estimate of the directivity was made by constructing an approximate three-dimensional pattern from the measured principal pattern cuts and integrating according to the standard definition of directivity. This gave a directivity of $D_0 = 81$ (19 dB), which leads to a total radiated power of 11.7 Watts, and an estimated power-combining efficiency of 96% based on the direct power measurements of the individual oscillators. The total

arrays drew 9 A of current at 8.5 V, giving a wall-plug efficiency of 15%.

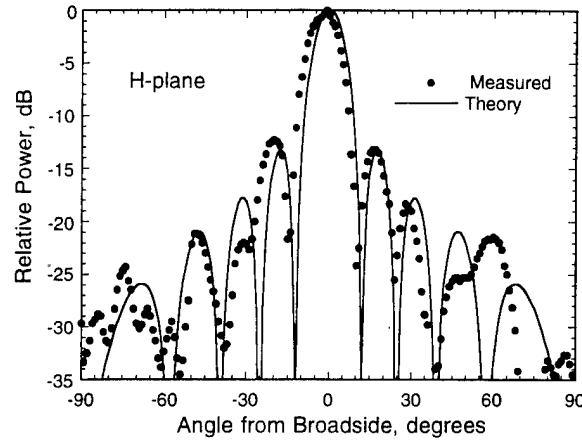

Figure 2 — Measured H-plane pattern for the 12 Watt 2×6 coupled oscillator array. The measured EIRP for this array was 933 Watts, with an estimated directivity of 81 (19 dB)

Chaotic Dynamics: The chaotic regimes of practical systems are currently of interest for a variety of potential applications including chaotic communications. Our interest stems from recent work in feedback control techniques, where it has been shown that chaotic systems can be stabilized and manipulated in very simple ways. A chaotic system in essence is constantly hopping between an infinite number of “orbits” in its return map. The feedback control techniques are designed to occasionally nudge the system back into a particular orbit whenever it begins to wander away. Interestingly, this nudge can be very small and can represent almost any parameter in the system. To understand why this could be useful in oscillator arrays, note that the power fluctuation in figure 3 implies that the main-lobe of the radiation pattern is constantly in motion. Using an appropriate feedback network, the system could be stabilized into a desired phase-plane trajectory which would correspond to a desired scanning pattern. We have recently demonstrated that our models do lead to low-dimensional chaotic behavior for systems of four oscillators. A typical chaotic output power waveform and corresponding return map computed from our dynamic models are shown in figure 3.

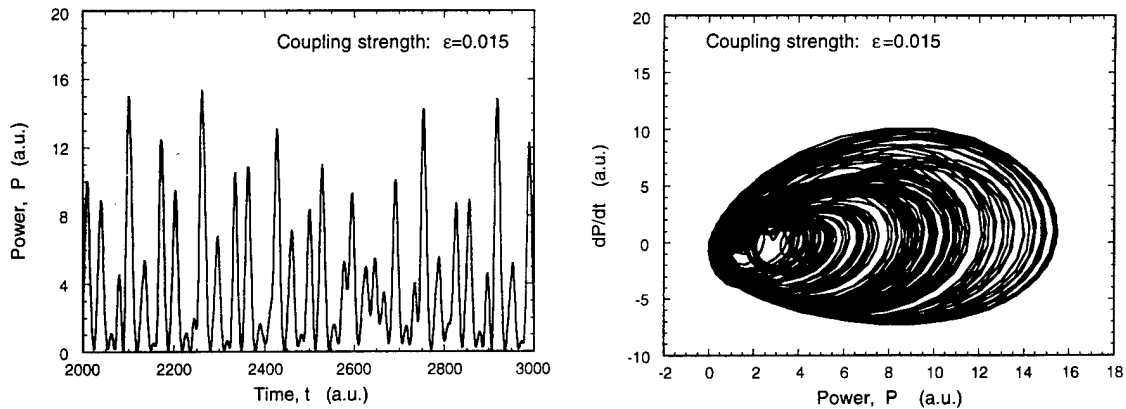

Figure 3 — (Left) Output power waveform for a weakly-coupled 4-element oscillator array, showing apparent chaotic behavior. (Right) Corresponding phase-plane diagram.

Nonlinear Dynamics of Quasi-Optical Device Arrays

FINAL REPORT

Dr. Robert A. York

30 December 1996

U.S. Army Research Office

ARO Proposal: 33098-EL-YIP

Grant Number: DAAH04-93-G-0210

*Department of Electrical and Computer Engineering
University of California at Santa Barbara
Santa Barbara, CA 93106*

Approved for Public Release;
Distribution Unlimited.

THE VIEWS, OPINIONS, AND/OR FINDINGS CONTAINED IN THIS REPORT ARE THOSE OF THE AUTHOR AND SHOULD NOT BE CONSTRUED AS AN OFFICIAL DEPARTMENT OF THE ARMY POSITION, POLICY, OR DECISION, UNLESS SO DESIGNATED BY OTHER DOCUMENTATION.

Table of Contents

| | |
|--|----|
| A. Statement of Problem Studied | 1 |
| B. Summary of Important Results | 1 |
| B.1 Theoretical Developments..... | 2 |
| B.2 High Power Array..... | 3 |
| B.3 Scanning Arrays..... | 5 |
| B.4 Refinements..... | 8 |
| B.5 Enhanced Locking Range VCO..... | 10 |
| B.6 Phase Noise Reduction..... | 11 |
| C. List of Publications and Reports | 13 |
| D. Participating Scientific Personnel | 15 |

A. STATEMENT OF THE PROBLEM

This project involved an exploration of mutual synchronization phenomenon in coupled-oscillator systems. The systems under study were comprised of microwave or millimeter-wave oscillators arranged in a one or two-dimensional array. Each oscillator delivers its power to a planar antenna structure so that the power is collected and combined radiatively, or "quasi-optically". The oscillators are coupled together either through radiative interactions between the antennas, or through dedicated transmission-line circuits. Such systems can be used for coherent power combining of solid-state sources.

The behavior of coupled nonlinear oscillators is complicated. Simple dynamic modelling based on approximate equivalent circuits for the oscillators and coupling mechanisms was developed. The efficacy of this approach was examined during the project through careful experimental study. Critical issues for practical implementation of the approach were identified. Novel beam-scanning and pulse generating concepts were discovered and verified experimentally. During the latter stages of the project, refinements to the basic models and experimental prototypes were developed for improved performance. Finally, noise performance of the arrays was undertaken. The results of these efforts are summarized below; additional technical details can be found in the publications listed in section C.

B. SUMMARY OF IMPORTANT RESULTS

- Developed and verified a technique for dynamic modelling of oscillators coupled through arbitrary broadband circuits
- Discovered a simple technique for beam scanning in oscillator arrays which produces a linear phase progression simply by detuning peripheral array elements. This was verified experimental with numerous array prototypes operating from 4 GHz to 11 GHz.
- Demonstrated a 12 Watt two-dimensional coupled-oscillator array using a 2×6 array of 1 Watt microwave oscillators operating at 11 GHz, feeding a set of patch antennas. This array produced an effective radiated power of 933 Watts.
- Developed a simple technique for enhancing the scanning range using a set of frequency doublers. Experimental prototype operating at 8 GHz demonstrated a scanning range of 80° ($\pm 40^\circ$ around broadside) using patch antennas.
- Demonstrated the scanning array concept in a receiving mode as well as a transmitting mode.
- Developed a theoretical technique for dynamic modelling of oscillators coupled through resonant circuits, such as external Fabry-Perot cavities
- Developed and verified a coupled-phase-locked-loop technique for both beam-scanning and pulse generation (mode-locking) with improved locking range compared with coupled-oscillator systems, from 2-4 times larger depending on the PLL design.
- Developed a novel technique for enhancing the locking range of simple oscillators using a low frequency loop amplifier.
- Proved theoretically and experimentally that the phase noise in a coupled oscillator system is reduced in direct proportion to the number of oscillators.

Additional technical details for these items are given below. Note: for cited references please refer to section C.

B.1 Theoretical Developments

The practical use of nonlinear oscillators for coherent power-combining and phase control is based on the phenomenon of injection locking. Our approach to modelling synchronization phenomena is a complex amplitude method providing amplitude and phase dynamics of an oscillator array when coupled through an electrical N -port network as shown in figure 1. The coupling network is described in terms of Y -parameters, so that the input admittance at port i is

$$Y_{\text{circ},i} = \sum_{j=1}^N Y_{ij} \frac{V_j}{V_i} \quad (1)$$

where V_i is the terminal voltage at port i . Each oscillator circuit, described by Y_i^{osc} for the i th oscillator, contains an active device and embedding network, where the i th oscillator is described by a free-running frequency ω_i and free-running amplitude α_i . The load of each oscillator is typically the radiation resistance of a planar antenna (or the unit cell of a grid).

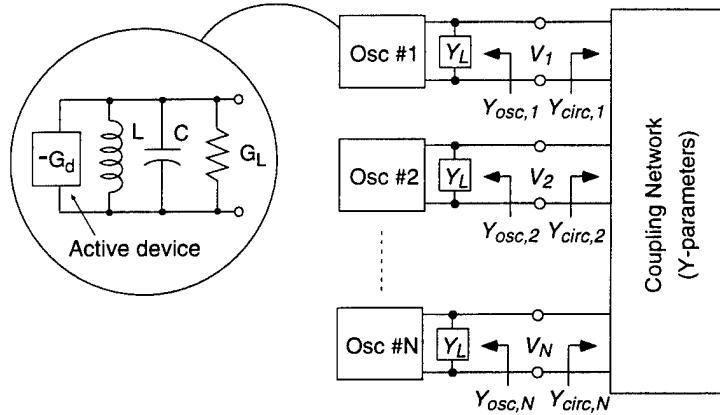

Figure 1 — Oscillator Array coupled by an arbitrary N -port network described by y -parameters.

For non-zero terminal voltages, the “connection” conditions

$$Y_i^{\text{osc}}(\omega, V_i) + Y_i^{\text{circ}}(\omega, \bar{V}) = 0 \quad i = 1, 2, \dots, N \quad (2)$$

must be satisfied at each frequency. For convenience, the total admittance at the i th port will be defined as $Y_i(\omega, \bar{V}) \equiv Y_i^{\text{osc}}(\omega, V_i) + Y_i^{\text{circ}}(\omega, \bar{V})$, so (2) is written as $Y_i(\omega, \bar{V}) = 0$. We anticipate sinusoidal (or nearly sinusoidal) oscillations of the form

$$V_i = A_i(t) e^{j[\omega_i t + \phi_i(t)]} = A_i(t) e^{j\theta_i(t)} \quad (3)$$

where the amplitude and phase are allowed to be slowly varying functions of time, and θ_i is the instantaneous phase of the i th oscillator. Considering the time derivative of V_i gives

$$\frac{dV_i}{dt} = j \left[\omega_i + \frac{d\phi_i}{dt} - j \frac{1}{A_i} \frac{dA_i}{dt} \right] V_i \quad (4)$$

Comparing (4) with the result from Fourier theory, $dV/dt \rightarrow j\omega V$, Kurokawa concluded that the expression in brackets must be the time-domain representation of the instantaneous frequency. Using this expression for the frequency, ω , and the slowly-varying approximations

$$\frac{d\phi_i}{dt} \ll \omega_i \quad \frac{1}{A_i} \frac{dA_i}{dt} \ll \omega_i \quad (5)$$

allows (2) to be expanded in a Taylor series about the free-running frequencies, leading to [7]

$$\begin{aligned}\frac{dA_i}{dt} &= A_i \operatorname{Im} \left\{ \left. \frac{Y_i}{\partial Y_i / \partial \omega} \right|_{\omega_i, A_i} \right\} \\ \frac{d\theta_i}{dt} &= \omega_i - \operatorname{Re} \left\{ \left. \frac{Y_i}{\partial Y_i / \partial \omega} \right|_{\omega_i, A_i} \right\}\end{aligned} \quad i = 1, 2, \dots, N \quad (6)$$

These equations describe the amplitude and phase dynamics for the coupled-oscillator system. Note that the total admittance Y_i depends nonlinearly on the amplitude and phase variables through (1), and hence (7) represent a complicated set of coupled nonlinear differential equations. We are most interested in steady-state solutions to (6) where all oscillators are synchronized to a common frequency, ω , which occurs when

$$\frac{dA_i}{dt} = 0 \quad \text{and} \quad \frac{d\theta_i}{dt} = \omega \quad i = 1 \dots N \quad (7)$$

A simple Van der Pol model (cubic nonlinearity, single-tuned circuit) is used for the oscillators, and all have nearly identical Q -factors and load conductances G_L but non-identical free-running frequencies and amplitudes. The total admittance and its derivative at each terminal are then [7]

$$\begin{aligned}Y_i(\omega_i, A_i) &= -\mu G_L f(A_i) + \sum_{j=1}^N Y_{ij} \frac{A_j}{A_i} e^{j(\theta_j - \theta_i)} \\ \left. \frac{\partial Y_i}{\partial \omega} \right|_{\omega_i} &= 2jQ G_L / \omega_i + \sum_{j=1}^N \left. \frac{\partial Y_{ij}}{\partial \omega} \right|_{\omega_i} \frac{A_j}{A_i} e^{j(\theta_j - \theta_i)}\end{aligned} \quad (8)$$

where $f(A_i) = (1 - A_i^2/\alpha_i^2)$, and μ is a dimensionless nonlinearity parameter [7]. Defining the normalized coupling parameters κ_{ij} as

$$\kappa_{ij} \equiv Y_{ij}/G_L \quad (9)$$

it can be shown [7] that for certain coupling structures the amplitude and phase dynamics are given by

$$\begin{aligned}\frac{dA_i}{dt} &= \frac{\mu\omega_i}{2Q} f(A_i) A_i - \frac{\omega_i}{2Q} \sum_{n=1}^N A_i \operatorname{Re} \left\{ \kappa_{in} e^{j(\theta_n - \theta_i)} \right\} \\ \frac{d\theta_i}{dt} &= \omega_i - \frac{\omega_i}{2Q} \sum_{n=1}^N \operatorname{Re} \left\{ \kappa_{in} \frac{A_n}{A_i} e^{j(\theta_n - \theta_i)} \right\}\end{aligned} \quad (10)$$

In the limit of strong coupling between the oscillators, the amplitude dynamics can be significant. Experiments have shown this to be an important factor in wide-angle scanning arrays, so a better understanding of the amplitude dynamics and suppression of undesirable amplitude fluctuations (or possible exploitation for beam shaping) is an important objective of the future work in this area.

B.2 High Power Array

For power-combining purposes, our best result using the coupled-oscillator concept has been a 6×2 array operating at 11 GHz [23]. This array used a transmission-line coupling network similar to previously reported arrays in this program, with two linear arrays of six oscillators interconnected

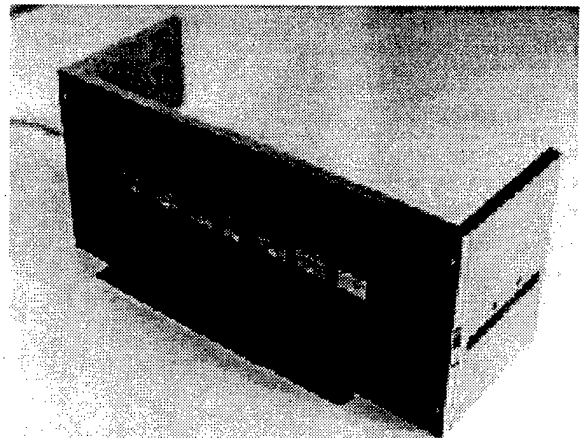
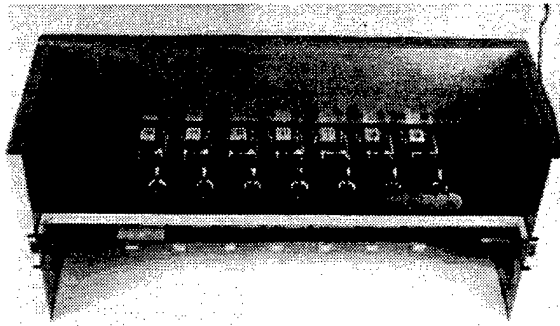

Figure 2 — Photograph of an 11 GHz power-oscillator array palette (rear-view and front-view) producing 6 Watts. The measured radiation pattern showing in-phase operation is given in fig. 3. The oscillators are to be connected to a patch array on the front board using coaxial feed-throughs.

at the edges to form a 12-element loop. The oscillators were designed around packaged GaAs power FETs (NEC 9008-11) in a feedback oscillator topology. Since this was a power design, care was taken to provide adequate heatsinking for the device. Consequently a “tray” approach was adopted as illustrated in figure 2, where each oscillator circuit was constructed on a Duroid substrate with a thick (quarter inch) Aluminum ground plane. Each oscillator fed a patch antenna on a separate board via short coaxial feed-throughs. The feed point on the probe-fed patches was selected to provide an optimal impedance match for maximum output power, which was determined empirically using a mechanical tuner and network analyzer. Each oscillator produced approximately 1 Watt in this configuration, under typical bias conditions of 8.5 V @ 900 mA.

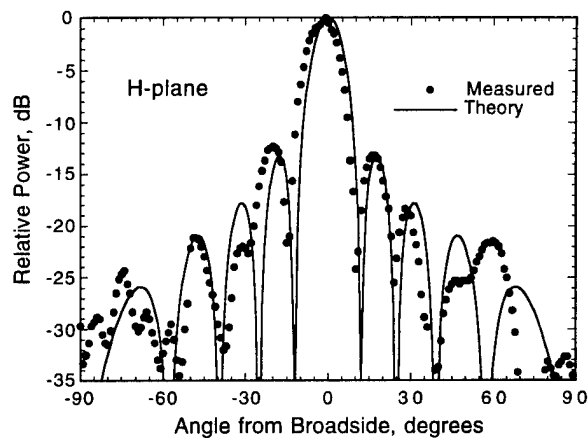

Figure 3 — Measured H-plane pattern for the 12 Watt 2×6 coupled oscillator array. The measured EIRP for this array was 933 Watts, with an estimated directivity of 81 (19 dB)

The array was built from two linear array oscillator “palettes”, one of which is shown in figure 2. The measured H-plane pattern for the 6×2 array is shown in figure 3. The measured Effective Isotropic Radiated Power (EIRP) for this array was 933 Watts. The E-plane patterns were distorted by the presence of additional parasitic patches on one side of the array (the array was actually a

sub-array of a larger 6×6 version. Since the E-plane pattern for this array did not closely match the theoretical pattern for a twelve element patch array, the total power could not be reliably estimated by finding the theoretical directivity for the array. An empirical estimate of the directivity was made by constructing an approximate three-dimensional pattern from the measured principal pattern cuts and integrating according to the standard definition of directivity. This gave a directivity of $D_0 = 81$ (19 dB), which leads to a total radiated power of 11.7 Watts, and an estimated power-combining efficiency of 96% based on the direct power measurements of the individual oscillators. The total arrays drew 9 A of current at 8.5 V, giving a wall-plug efficiency of 15%.

B.3 Scanning Arrays

For a single oscillator, (10) can be reduced to a form of Adler's equation for injection locking

$$\frac{d\theta}{dt} = \omega_0 + \frac{\omega_0}{2Q} \frac{A_{inj}}{A} \sin(\theta_{inj} - \theta) \quad (11)$$

where $\theta = \omega t + \phi(t)$ and $\theta_{inj} = \omega_{inj}t + \phi_{inj}$ are the instantaneous phases of the oscillator and the injected signal, respectively, A_{inj} and A are the amplitudes, similarly, and Q is the quality-factor of the oscillator resonant circuit. When the oscillator locks onto the injected signal, $d\theta/dt = \omega_{inj}$ in the steady-state, and (11) becomes

$$\omega_{inj} = \omega_0 + \Delta\omega_{lock} \sin \Delta\theta \quad \text{where} \quad \Delta\omega_{lock} = \frac{\omega_0}{2Q} \frac{A_{inj}}{A} \quad (12)$$

$\Delta\omega_{lock}$ is called the *locking bandwidth* of the oscillator, and $\Delta\theta$ is the steady-state phase difference between the oscillator and injected signal. Equation (12) indicates that as the injected signal frequency is tuned over the locking range of the oscillator, $\omega_0 \pm \Delta\omega_{lock}$, the phase difference will vary between $-90^\circ < \Delta\theta < 90^\circ$ as shown in figure 4.

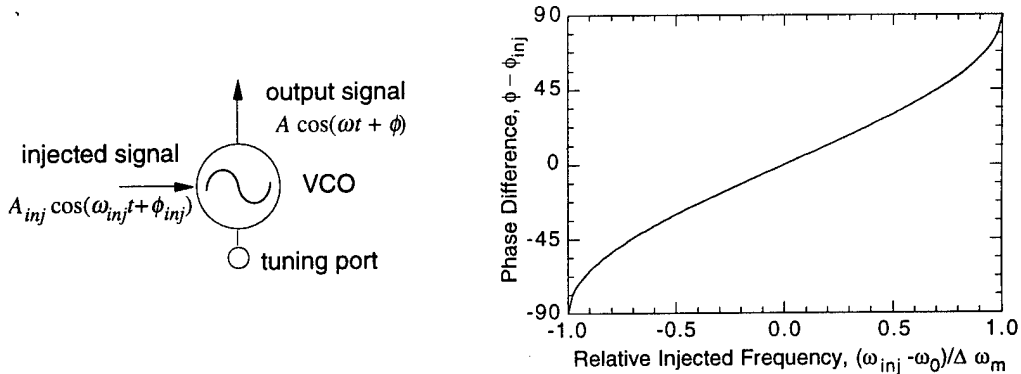

Figure 4 - Injection-locked oscillator and plot showing behavior of oscillator phase as injection frequency is varied relative to the free-running frequency.

The induced phase shift suggests the possibility of a simple technique for phase control in arrays. However, it is not trivial to graphically extrapolate the behavior of a coupled-oscillator array based on the result for a single oscillator shown in figure 4. Referring to equations (10), the steady-state phase distribution is a complicated *nonlinear* function of the oscillator tunings and amplitudes. For analytical simplicity and developing physical insight, we generally restrict attention to nearest-neighbor interaction and identical oscillators [3,7]. The mutual interaction between adjacent oscillators is described using a complex coupling coefficient, which is written in terms of a coupling strength and

phase as $\varepsilon \exp(-j\Phi)$, and can be related to the y - or z -parameters of the coupling circuit that connects the oscillators [7]. The phase dynamics of a system of N coupled oscillators can then be derived as

$$\frac{d\theta_i}{dt} = \omega_i - \frac{\varepsilon\omega_i}{2Q} \sum_{\substack{j=i-1 \\ j \neq i}}^{i+1} \sin(\Phi + \theta_i - \theta_j) \quad i = 1, 2, \dots, N \quad (13)$$

where ω_i , and θ_i are the frequency and instantaneous phase, respectively, of oscillator i , and Q is the Q -factor of the oscillator embedding circuits. When the free-running frequencies, ω_i , are similar enough, then the oscillators can lock to the same frequency so that $d\theta_i/dt = \omega$ in the steady-state. For beam-scanning a constant progressive phase shift of $\Delta\phi$ is required, represented mathematically as

$$\theta_i - \theta_{i-1} = \Delta\phi \quad i = 2 \dots N$$

Substituting this condition into (13) and assuming $\Phi = 0^\circ$ leads to a set of conditions on the free-running frequencies [2,3]

$$\omega_i = \begin{cases} \omega_0[1 - \Delta\omega_m \sin \Delta\phi]^{-1} & \text{if } i = 1 \\ \omega_0 & \text{if } 1 < i < N \\ \omega_0[1 + \Delta\omega_m \sin \Delta\phi]^{-1} & \text{if } i = N \end{cases} \quad (14)$$

where ω_0 is the desired steady-state synchronized frequency, and $\Delta\omega_m = \varepsilon\omega_0/2Q$ is the locking range. This indicates that a constant phase shift can be programmed by slightly detuning only the end elements of the array in opposite directions, independent of the number of oscillators in the array. This is a key advantage of the coupled-oscillator technique over other phase control methods, i.e. only peripheral array elements need to be manipulated. This is a remarkable result, but one that has resisted a simple physical interpretation and therefore broad acceptance in the field.

Although (4) seems to imply that any phase shift $\Delta\phi$ can be obtained, a stability analysis of (3) puts limits on this quantity [2,3]. For the special case of $\Phi = 0^\circ$, the limits are

$$-90^\circ < \Delta\phi < 90^\circ$$

In a typical array with element spacing of $d = \lambda_0/2$, this phase shift is sufficient to scan the beam over a $\pm 30^\circ$ range. This simplified analysis serves to introduce the beam-scanning concept, but in reality the dynamics are complicated by many factors that have been left out of (1), such as amplitude dynamics and non-uniformities, frequency-dependent coupling networks, non-nearest-neighbor interactions, non-uniform tuning profiles of the VCOs, and frequency-dependent device characteristics. Frequency-dependent coupling networks have been addressed recently in [10]; most of the remaining issues could be treated in a future work effort.

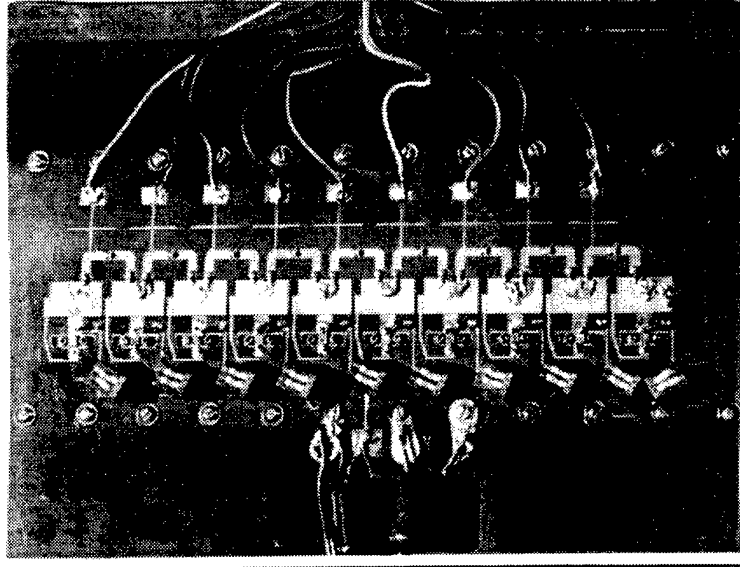

Figure 5 — Photograph of an 8-element MESFET VCO array using patch antennas, operating at 8.4 GHz.

In practice the implementation of the scanning oscillator array concept at microwave frequencies is complicated by the complexity of microwave oscillators (from an impedance point of view), the difficulty in controlling parasitics and device parameters variations, and the distributed nature of the coupling networks. Some of these problems are addressed later. To date our work has focused primarily on proof-of-concept arrays using very simple (in some cases crude) oscillator designs and coupling networks. Several prototypes have been made [2,4,15,20,21]; one scanning array is shown in figure 5, where a number of simple MESFET oscillators with patch antenna loads are coupled via resistively-loaded one-wavelength transmission lines. The array used a simple VCO based on a varactor-tuned patch antenna [6], and produced over 1 Watt at 8.4 GHz with a total scanning range of 45° (-15° to $+30^\circ$ around broadside). Typical radiation patterns are shown below [20].

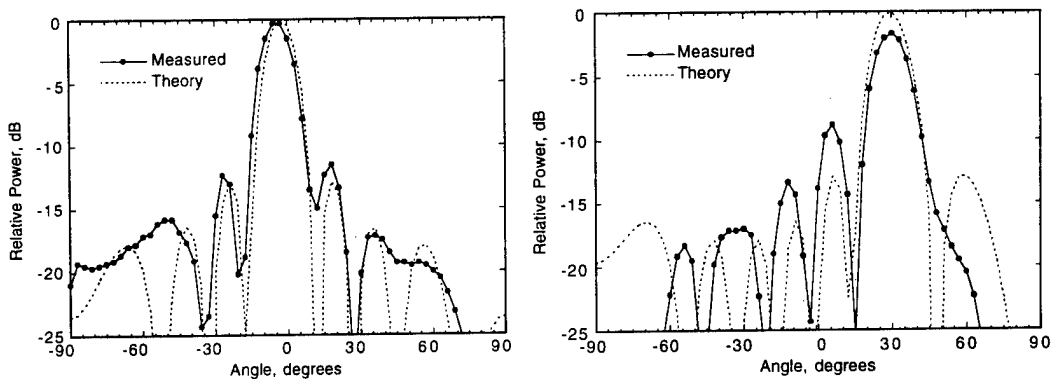

Figure 6 - Measured radiation patterns for two representative varactor tunings for the array of figure 5. A total scan range of 45° was achieved [20].

Note in figure 5 that as the beam pattern is scanned, a degradation in sidelobe levels is observed. This has been frequently observed in our prototypes, and appears to be a result of a complex interplay of the amplitude dynamics, coupling network design, and oscillator power variations and intrinsic

nonlinearity (or gain saturation). A future effort could address this problem.

B.4 Refinements

One apparent limitation of the injection-locked or coupled-oscillator topologies (for some applications) is the limited range of phase shifts that can be synthesized. This can be improved using the topology shown in figure 7 below. A frequency doubler circuit is used at each array element which effectively doubles the inter-element phase shift, which extends the theoretical scanning range to full hemispherical coverage [25]. The signals can then be amplified (for additional power and efficiency) and fed to a planar radiating element.

This technique has some other potential benefits: the oscillators can be designed at a lower frequency (half the desired output frequency), which is useful because oscillators are sensitive to parasitic reactances in hybrid circuits, and also because oscillator design is simpler when the device has high gain, which is more easily achieved at lower frequencies. The range of oscillator tuning required to achieve a given scan range is also significantly reduced, which is advantageous since operation of the array near the locking band edge is undesirable due to increased phase noise, reduced modulation range, and increased sensitivity to environmental disturbances. For $\pm 45^\circ$ scanning in a frequency-doubled array (half-wavelength spacing), the relationship between oscillator tunings and interelement phase-shift (fig. 4) is quite linear, which makes calibration and scan control circuit design much simpler. Finally, the doublers (and possibly amplifiers) following the oscillators provide a desirable measure of isolation between the antenna and oscillator. This has been a source of problems in the past, since load pulling effects due to phase-sensitive mutual coupling between antennas and environmental disturbances could cause the array to lose phase-lock. Using FET-based doublers, a stable broadband load impedance is presented to the oscillators. A prototype array has been demonstrated [25], achieving a total phase variation of $\approx 260^\circ$.

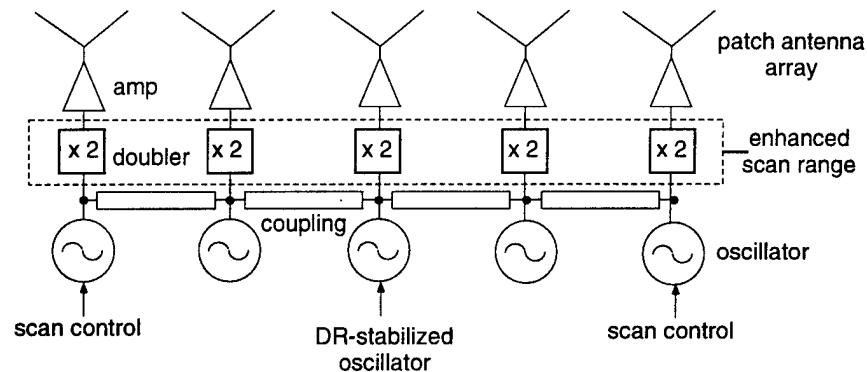

Figure 7 - An improved version of the scanning oscillator concept uses frequency doublers to increase the scan range, and a low-noise source to stabilize the array, as well as power amplifiers to buffer the oscillators and increase output power.

Industrial affiliates also expressed interest in lowering the phase-noise of the oscillator arrays (particularly for receiver applications). This will be especially important in a frequency-doubled array since the oscillator noise is also doubled. Low noise can be achieved by injecting a stable reference signal (which could also contain modulation) into the *center* element of the array, as shown in the figure 7. We have shown theoretically that this does not affect the scanning technique, and have measured dramatic improvement in phase noise, suitable for sensitive receiver applications using an earlier array prototype [24]. Typical measurements for a 5-element MESFET array are shown in figure 8

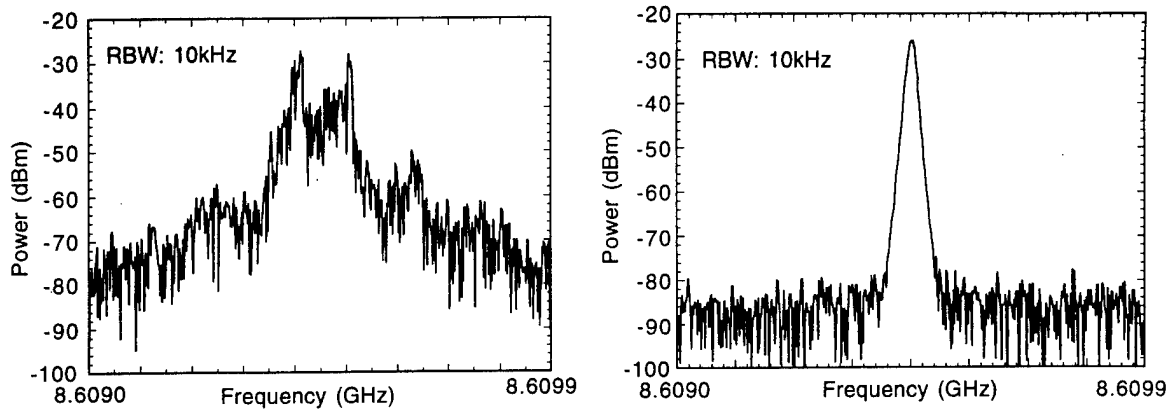

Figure 8 — (Left) Free-running spectrum of a 5-element $0.25\ \mu\text{m}$ GaAs MESFET array (oscillator $Q \approx 20$). (Right) Spectrum of same array after injection-locking the center-element to a YIG-stabilized Gunn oscillator.

below, showing the noise improvement after injection-locking the center-element to a YIG-stabilized Gunn oscillator.

The scanning oscillator configurations can also be used for receiving applications [26]. This is accomplished by using the scanning oscillator array as the local oscillator for a set of mixers, as shown in figure 9. Using one of our early array prototypes and some commercial packaged mixers, this concept was tested by first measuring the scanning properties in transmit mode (oscillators coupled directly to antennas), followed by the receive mode as shown. Identical scan ranges and patterns observed in each case, as expected. It may be possible to merge the transmit and receive functions, especially for FMCW imaging arrays, by making each array element a self-contained FMCW transmitter and receiver, where each array element is coupled to its neighbors. This has not yet been tested. It may also be possible to accomplish the receiving function with a subset of the total array elements, thereby saving on the number of additional circuit components that are required.

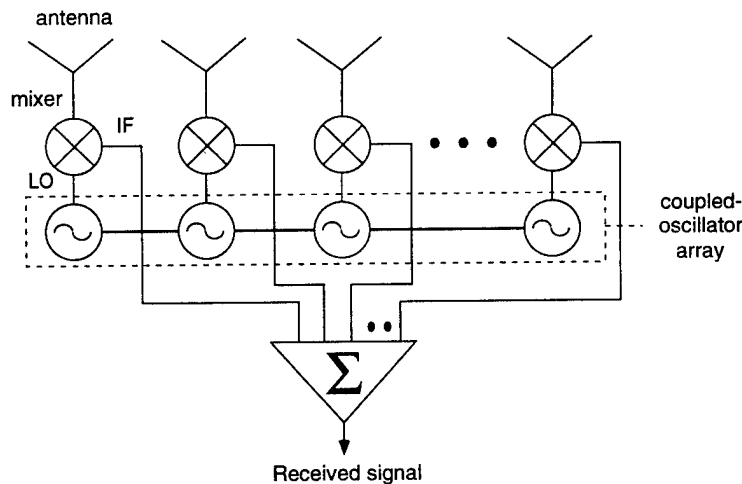

Figure 9 - The coupled-oscillator technique can be used for scanning receivers by using the array as a distributed local oscillator.

A further refinement of the coupled oscillator technique is the use of phase-locked-loop (PLL) tech-

niques to phase-lock the array elements [9,28], instead of the nonlinear injection-locking process. This is shown in figure 10. The phase dynamics of simple phase-locked loops are almost identical to that predicted by Adler's equation, hence all of the previously developed scanning techniques would be preserved. The benefit of this technique is more robust operation; the array elements are forced to lock to each other, and the locking or capture range can be much larger than that achieved with injection-locking techniques. In addition, the PLL technique does not suffer adversely from dynamic amplitude variations when strongly coupled, which appears to be a limiting factor in the coupled-oscillator technique. The disadvantage is, of course, the added complexity of the PLL circuitry. However, it is conceivable that a suitable PLL MMIC chip could be developed for use in such arrays, which would be cost effective in comparison to stand-alone VCO chips. Microwave prototypes of both a mutually synchronized PLL array and a "mode-locked" (pulsed) array [9] have been demonstrated.

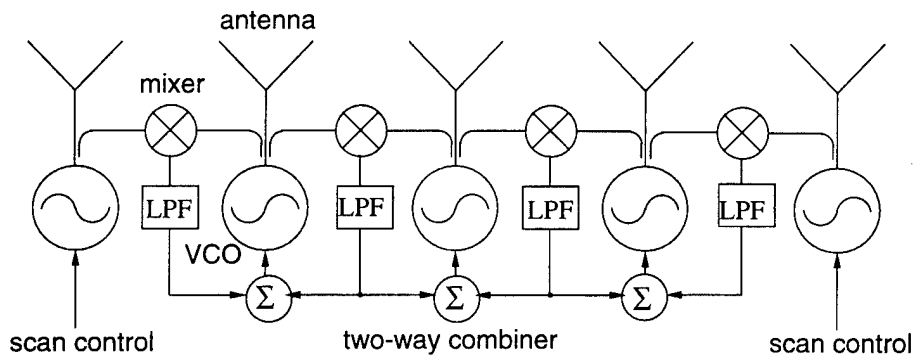

Figure 10 - Simple Phase-Locked Loop (PLL) circuits can be used as drop-in replacements for the oscillators with a large benefit in terms of bandwidth and sensitivity to circuit tolerances.

B.5 VCO with Enhanced-Locking Range

We mentioned the potential for phase-locked loop (PLL) techniques to be advantageously employed in coupled-oscillator configurations (figure 10). To the extent that FET oscillators can be used as self-oscillating mixers, we have demonstrated the possibility of making extremely simple PLL circuits by making only a slight modification to our standard VCO designs, as shown in figure 11a.

The essential point is that the nonlinearity of the device will mix the oscillator output against an injected signal, so mixing products will be superimposed on the oscillator output. If these low-frequency signals are amplified and fed back to the varactor tuning element appropriately, a PLL is created. This can be proved as follows. The VCO is designed so that the output frequency ω is a function of the varactor voltage V_b ,

$$\omega = \omega_0 + 2\pi KV \quad (24)$$

where K is the VCO tuning sensitivity (Hz/Volt). With the feedback loop shown in fig. 11a, the varactor voltage is given by

$$V = \alpha GA_0 A_{inj} \sin(\Delta\theta) \quad (25)$$

where α is the mixer conversion loss, G is the loop gain, A_0 and A_{inj} are the output and injected signal amplitudes, respectively, and $\Delta\theta$ is the relative phase difference of the two signals. When (24) and (25) are combined, the result is Adler's equation (or a first-order PLL equation) with a locking range given by

$$\Delta f_m = K\alpha GA_0 A_{inj} \quad (26)$$

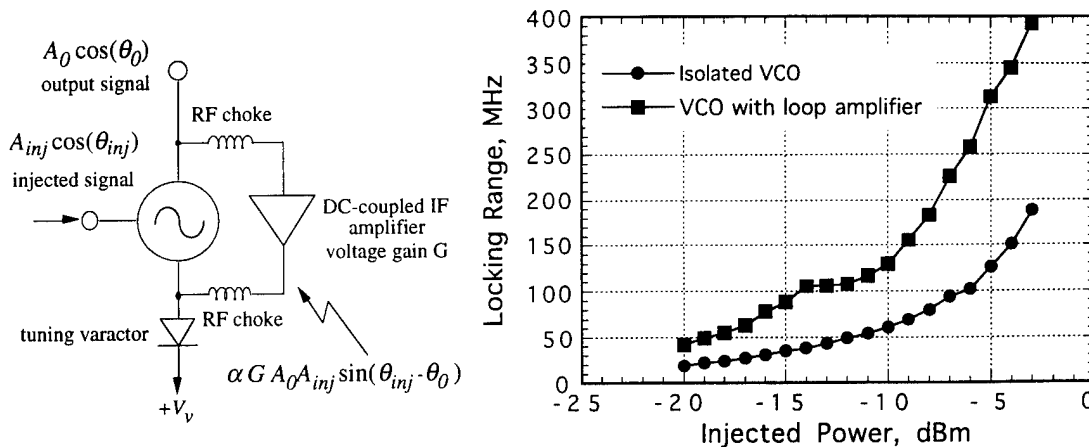

Figure 11 — (a) Simple PLL circuit concept using a FET oscillator with low-frequency feedback loop. (b) Preliminary measurements shown significant improvement in locking range using a 20dB loop gain in an X-band MESFET VCO.

This gives us some obvious ways to increase the locking range of the system without adversely affecting other dynamical aspects. Most importantly we require a large tuning sensitivity and a large loop gain.

A prototype has been constructed by simply adding a low-frequency DC-coupled amplifier (20 dB gain) to an existing X-band oscillator. The resulting locking range for this particular case is shown in figure 11b, and shows a significant increase over the injection-locking range for the same oscillator without feedback. We have proven that this is not simply a result of loading (which would lower the oscillator Q) since the feedback can also be made to lower the locking range by reversing the varactor polarity. This is a very simple technique for increasing the locking range, which should lead to robust power-combining and scanning arrays, while simultaneously reducing amplitude fluctuations.

B.6 Phase Noise Analysis

Regarding the practical use of oscillator arrays, phase noise has been identified as an important problem for study. This is a difficult subject. Intuitively one would anticipate a decrease in noise in an array environment as the array size increases, since the source of noise in each oscillator are independent random processes and would add incoherently, whereas the desired signal adds coherently. In the case of amplifier arrays, such as in a radiometric receiver array, it is well known that the lack of correlation of the noise fluctuations between array elements leads to a $1/\sqrt{N}$ dependence of total phase noise for the ensemble, where N is the number of array elements. The case of a mutually synchronized nonlinear oscillator array is much more complicated, because the mutual coupling between oscillators and nonlinear synchronization mechanisms leads to a partial correlation of the voltage fluctuations at the output of each oscillators. Computing the autocorrelation of the combined output waveform is therefore a difficult process.

We have examined phase noise in oscillator arrays [12] and shown that the noise is reduced in proportion to $1/N$. This was verified by experiments using a 5-element MESFET array. Figure 12 shows the noise measurements on this array. Also examined were the noise properties of the array under external injection locking. The measurements show excellent agreement in comparison to theoretical predications; some examples of the latter are shown in figure 13. The theory is involved,

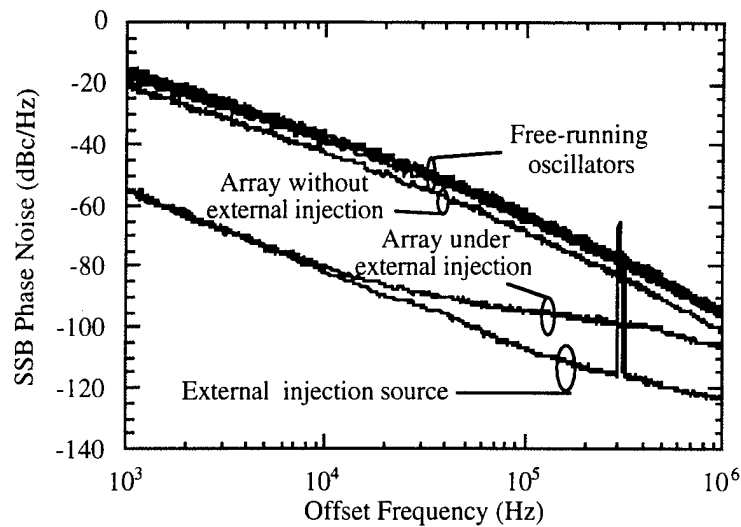

Figure 12 - Measurements of array phase noise in the free-running and injection-locked modes, and comparison to the individual oscillators and injected sources.

so the reader is referred to our recent paper [12]. The result for external locking shows that the array assumes the noise properties of the external source near the carrier, and reduces to the free-running array noise (which involves the $1/N$ reduction) far from the carrier. The results bode well for practical applications making use of coupled-oscillator techniques.

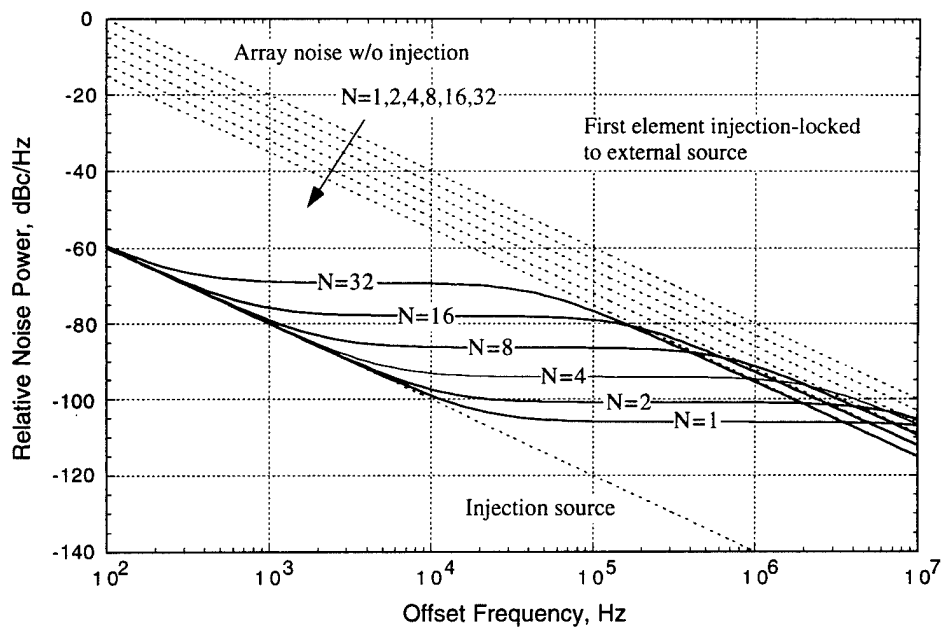

Figure 13 - Theoretical computation of phase noise versus offset frequency for different numbers of array elements.

C. LIST OF PUBLICATIONS AND REPORTS:

Books:

- B.1 *Active and Quasi-Optical Arrays for Solid-State Power Combining*, R. York and Z. Popović, eds., Wiley: New York. *In Press, due out March 1997.*

Book Chapters:

- C.1 R.A. York, "Quasi-Optical Power-Combining Techniques" in *Millimeter and Microwave Engineering for Communications and Radar*, J. Wiltse, ed., vol. CR54, pp. 63–97, SPIE Press: Bellingham, Washington, 1994.
- C.2 R.A. York, "Quasi-Optical Power-Combining" in *Active and Quasi-Optical Arrays for Solid-State Power Combining*, R. York and Z. Popović, eds., Chapter 1, Wiley: New York. *In Press.*
- C.3 J.J. Lynch, H.C. Chang, and R.A. York, "Coupled-Oscillator Arrays and Scanning Techniques" in *Active and Quasi-Optical Arrays for Solid-State Power Combining*, R. York and Z. Popović, eds., Chapter 4, Wiley: New York. *In Press.*

Journal Papers (listed chronologically)

1. H.P. Moyer and R.A. York, "Active cavity-backed slot antenna using MESFETs", *IEEE Microwave Guided Wave Lett.*, vol. 3, pp. 95–97, April 1993.
2. R.A. York and P. Liao, "A new phase-shifterless beam-scanning technique using arrays of coupled oscillators", *IEEE Trans. Microwave Theory Tech.*, special issue on quasi-optical techniques, vol. MTT-41, pp. 1810–1815, October 1993.
3. R.A. York, "Nonlinear analysis of phase relationships in quasi-optical oscillator arrays", *IEEE Trans. Microwave Theory Tech.*, special issue on quasi-optical techniques, vol. MTT-41, pp. 1799–1809, October 1993.
4. P. Liao and R.A. York, "A six-element scanning oscillator array", *IEEE Microwave Guided Wave Lett.*, vol. 4, no. 1, pp. 20–22, Jan 1994.
5. J.J. Lynch and R.A. York, "Stability of mode-locked states of coupled oscillator arrays", *IEEE Trans. Circuits and Systems, IEEE Trans. Circuits and Systems—I. Fundamental Theory and Applications*, vol. 42, pp. 413–418, August 1995.
6. P. Liao and R.A. York, "A varactor-tuned patch oscillator for active arrays", *IEEE Microwave Guided Wave Lett.*, vol. 4, no. 10, pp. 335–337, October 1994.
7. R.A. York, P. Liao, J.J. Lynch, "Oscillator array dynamics with broadband N-port coupling networks", *IEEE Trans. Microwave Theory Tech.*, vol. MTT-42, pp. 2040–2045, November 1994.
8. J.J. Lynch and R.A. York, "An analysis of mode-locked arrays of automatic level control oscillators", *IEEE Trans. Circuits and Systems—I. Fundamental Theory and Applications*, vol. 41, pp. 859–865, December 1994.
9. J.J. Lynch and R.A. York, "Mode-Locked Arrays of Coupled Phase-Locked Loops", *IEEE Microwave Guided Wave Lett.*, vol. 5, no. 7, pp. 213–215, July 1995.
10. J.J. Lynch and R.A. York, "Oscillator dynamics with frequency dependent coupling networks", to appear in *IEEE Trans. Microwave Theory Tech.*

11. R.J. Ram, R. Sporer, H.-R. Blank, P. Maccarini, H.-C. Chang, and R.A. York, "Chaos in Microwave Antenna Arrays", submitted to *IEEE Trans. Microwave Theory Tech.*, March 1996.
12. H.-C. Chang and R.A. York, "Phase Noise in Coupled Oscillators: Theory and Experiment", to appear in *IEEE Trans. Microwave Theory Tech.*, May 1996.
13. H.-C. Chang, E.S. Shapiro, and R.A. York, "Influence of the Oscillator Equivalent Circuit on the Stable Modes of Parallel-Coupled Oscillators", submitted to *IEEE Trans. Microwave Theory Tech.*, December 1996.

Conference Papers (listed chronologically)

14. H.P. Moyer and R.A. York, "Active cpw-fed slot antennas", presented at the *1993 Benjamin Franklin Symposium*, (Philadelphia) May 1993.
15. P. Liao and R.A. York, "Phase-shifterless beam-scanning using coupled oscillators: theory and experiment", *1993 IEEE Antennas & Propagation Society Symposium* (Ann Arbor, Michigan), June 1993.
16. R.A. York, "Toward an understanding of coupled oscillator dynamics for power-combining and beam-scanning arrays", *1993 Workshop on Millimeter-Wave Power Generation and Beam Control*, (Redstone Arsenal, Alabama), RD-AS-94-4, pp. 251-258, Sept 1993.
17. J.J. Lynch and R.A. York, "Mode-locked arrays of microwave oscillators", *1993 International Symposium on Nonlinear Theory and its Applications (NOLTA)*, (Hawaii), pp. 605-608, December 1993.
18. R.A. York, "Quasi-optical power-combining", (Invited Paper), *SPIE Int. Conf. on Millimeter and Submillimeter Waves* (San Diego), vol. 2250, Jan 1994.
19. J.J. Lynch and R.A. York, "Pulse power enhancement using mode-locked arrays of automatic level control oscillators", *IEEE MTT-S International Microwave Symposium* (San Diego), pp. 969-972, June 1994.
20. P. Liao and R.A. York, "A 1 Watt X-band power-combining array using coupled VCOs", *IEEE MTT-S International Microwave Symposium Digest* (San Diego), pp. 1235-1238, June 1994.
21. P. Liao and R.A. York, "Beam scanning with coupled VCO's", *IEEE Antennas and Propagation Society Symp. Dig.* (Seattle), pp. 836-839, June 1994.
22. H.-S. Tsai, P. Liao, J.J. Lynch, A. Alexanian, and R.A. York, "Active Antenna Arrays for Millimeter-wave Power-Combining", *1994 International Conference on Millimeter-waves and Far-Infrared science and Technology* (Guangzhou, China), pp. 371-374, Sept 1994.
23. P. Liao and R.A. York, "A high power two-dimensional coupled oscillator array at X-band", *1995 IEEE MTT-S International Microwave Symposium* (Orlando), pp. 909-912.
24. X. Cao and R.A. York, "Phase noise reduction in scanning oscillator arrays", *1995 IEEE MTT-S International Microwave Symposium* (Orlando), pp. 769-772.
25. A. Alexanian, H.C. Chang and R.A. York, "Enhanced scanning range in coupled oscillator arrays utilizing frequency multipliers", *1995 IEEE Antennas and Propagation Society Symposium Digest* (Newport Beach, CA), pp. 1308-1310.
26. X. Cao and R.A. York, "Coupled Oscillator Scanning Technique for Receiver Applications", *1995 IEEE Antennas and Propagation Society Symposium* (Newport Beach, CA), pp. 1311-1314.
27. H.C. Chang and R.A. York, "Optical control of scanning oscillator arrays", *USNC/URSI Radio Science Meeting Digest* (Newport Beach, CA), pp.135 (abstract only), 1995.
28. R.A. York, "Novel beam scanning techniques for low cost commercial applications", (Invited Paper), *SPIE Int. Conf. on Millimeter Waves and Applications* (San Diego), July 1995.

29. R.A. York, "Integrated antennas and quasi-optical device arrays" (Invited paper), *Fifteenth biennial IEEE/Cornell University conference on Advanced Concepts in High-Speed Semiconductor Devices and Circuits*, (Ithaca, NY), August 1995.
30. R.A. York, "Scanning oscillator arrays for low cost transceivers" (Invited paper), *1995 URSI International Symposium on Signals, Systems, and Electronics* (San Francisco, CA), October 1995.
31. R.J. Ram, R. Sporer, H.-R. Blank, P. Maccarini, H.-C. Chang, and R.A. York, "Chaos in Microwave Antenna Arrays" (Invited paper), *1996 IEEE MTT-S International Microwave Symposium* (San Francisco).
32. H.-C. Chang and R.A. York, "Enhanced MESFET VCO Injection-Locking Bandwidth using Low Frequency Feedback Techniques", *1996 IEEE MTT-S International Microwave Symposium* (San Francisco).

D. PARTICIPATING SCIENTIFIC PERSONNEL

Personnel supported over the duration of the award were:

Robert A. York, PI
Arvind Keerthi, graduate student
Peter Liao, graduate student
Jonathan Lynch, graduate student

Degrees Awarded:

PhD degree: Jonathan Lynch, March, 1995
PhD degree: Peter Liao, September 1995

Student Honors:

Peter Liao: 2nd place in student paper contest at 1994 IEEE MTT conference
Peter Liao: 2nd place in student paper contest at 1994 IEEE AP-S conference

Contract: 30853-EL-YIP
Title: Nonlinear Dynamics of Quasi-Optical Device Arrays
PI: Prof. Robert A. York

1. List of Manuscripts submitted or published under ARO sponsorship during this reporting period:

Journal Papers (listed chronologically)

1. J.J. Lynch and R.A. York, "Mode-Locked Arrays of Coupled Phase-Locked Loops", *IEEE Microwave Guided Wave Lett.*, vol. 5, no. 7, pp. 213-215, July 1995.
2. J.J. Lynch and R.A. York, "Oscillator dynamics with frequency dependent coupling networks", to appear in *IEEE Trans. Microwave Theory Tech.*
3. R.J. Ram, R. Sporer, H.-R. Blank, P. Maccarini, H.-C. Chang, and R.A. York, "Chaos in Microwave Antenna Arrays", submitted to *IEEE Trans. Microwave Theory Tech.*, March 1996.
4. H.-C. Chang and R.A. York, "Phase Noise in Coupled Oscillators: Theory and Experiment", to appear in *IEEE Trans. Microwave Theory Tech.*, May 1996.
5. H.-C. Chang, E.S. Shapiro, and R.A. York, "Influence of the Oscillator Equivalent Circuit on the Stable Modes of Parallel-Coupled Oscillators", submitted to *IEEE Trans. Microwave Theory Tech.*, December 1996.

Conference Papers (listed chronologically)

1. P. Liao and R.A. York, "A high power two-dimensional coupled oscillator array at X-band", *1995 IEEE MTT-S International Microwave Symposium* (Orlando), pp. 909-912.
2. X. Cao and R.A. York, "Phase noise reduction in scanning oscillator arrays", *1995 IEEE MTT-S International Microwave Symposium* (Orlando), pp. 769-772.
3. A. Alexanian, H.C. Chang and R.A. York, "Enhanced scanning range in coupled oscillator arrays utilizing frequency multipliers", *1995 IEEE Antennas and Propagation Society Symposium Digest* (Newport Beach, CA), pp. 1308-1310.
4. X. Cao and R.A. York, "Coupled Oscillator Scanning Technique for Receiver Applications", *1995 IEEE Antennas and Propagation Society Symposium* (Newport Beach, CA), pp. 1311-1314.
5. H.C. Chang and R.A. York, "Optical control of scanning oscillator arrays", *USNC/URSI Radio Science Meeting Digest* (Newport Beach, CA), pp.135 (abstract only), 1995.
6. R.A. York, "Novel beam scanning techniques for low cost commercial applications", (Invited Paper), *SPIE Int. Conf. on Millimeter Waves and Applications* (San Diego), July 1995.
7. R.A. York, "Integrated antennas and quasi-optical device arrays" (Invited paper), *Fifteenth biennial IEEE/Cornell University conference on Advanced Concepts in High-Speed Semiconductor Devices and Circuits*, (Ithaca, NY), August 1995.
8. R.A. York, "Scanning oscillator arrays for low cost transceivers" (Invited paper), *1995 URSI International Symposium on Signals, Systems, and Electronics* (San Francisco, CA), October 1995.

2. Scientific Personell and Degrees Awarded:

Personell supported during this contract period were:
Robert A. York, PI
Peter Liao, gradute student

Honors/Degrees Awarded:
PhD degree: Jonothan Lynch, March, 1995
PhD degree: Peter Liao, September 1995