

FWS/OBS-83/10
MARCH 1983

PRACTICES FOR PROTECTING AND ENHANCING FISH AND WILDLIFE ON COAL SURFACE-MINED LAND IN THE POWDER RIVER-FORT UNION REGION

DEPARTMENT OF THE INTERIOR
Approved for public release
Distribution Unlimited



19970320 100

Fish and Wildlife Service

In cooperation with
Bureau of Mines

U.S. Department of the Interior

DETC QUALITY INSPECTED 2

There are five manuals in this series:

Practices for protecting and enhancing fish and wildlife on coal surface-mined land in Central and Southern Appalachia. FWS/OBS-83/08.

Practices for protecting and enhancing fish and wildlife on coal surface-mined land in the Green River-Ham's Fork region. FWS/OBS-83/09.

Practices for protecting and enhancing fish and wildlife on coal surface-mined land in the Powder River-Fort Union region. FWS/OBS-83/10.

Practices for protecting and enhancing fish and wildlife on coal surface-mined land in the Southcentral U.S. FWS/OBS-83/11.

Practices for protecting and enhancing fish and wildlife on coal mined land in the Uinta-Southwestern Utah region. FWS/OBS-83/12.

FWS/OBS-83/10
March 1983

PRACTICES FOR PROTECTING AND ENHANCING FISH
AND WILDLIFE ON COAL SURFACE-MINED LAND IN THE
POWDER RIVER-FORT UNION REGION

by

Bettina R. Proctor
Richard W. Thompson
Jane E. Bunin
Kenneth W. Fucik
George R. Tamm
Edward G. Wolf
Science Applications, Inc.
2760 29th Street, Suite 209
Boulder, CO 80301-1293

FWS 14-16-0009-80-075

Project Officer

Phillip L. Dittberner
Western Energy and Land Use Team
2627 Redwing Road
Fort Collins, CO 80526

Performed for

Western Energy and Land Use Team
Division of Biological Services
Research and Development
Fish and Wildlife Service
U.S. Department of the Interior
Washington, DC 20240

DISCLAIMER

Mention of trade names or commercial products does not constitute endorsement or recommendation for use by the Division of Biological Services, Fish and Wildlife Service, U.S. Department of the Interior.

This report should be cited as:

Proctor, B. R., R. W. Thompson, J. E. Bunin, K. W. Fucik, G. R. Tamm, and E. G. Wolf. 1983. Practices for protecting and enhancing fish and wildlife on coal surface-mined land in the Powder River-Fort Union region. U.S. Dept. Int. Fish Wildl. Serv. FWS/OBS-83/10. 246 pp.

PREFACE

This handbook contains information on the best current practices to protect and enhance fish and wildlife resources on surface-mined land in the Northern Great Plains. Current State and Federal legislation was reviewed to determine those practices which were most compatible with the performance standards related to Best Technology Currently Available, Fish and Wildlife Plans, and Reclamation Plans. The information presented in the handbook is region-specific, including risks and limitations, approximate cost, and maintenance and management requirements of each practice. Reclamation plans, which integrate the best current practices with the restoration of specific habitats in the region, are also included.

This work was supported by funding from the U.S. Bureau of Mines, Minerals Environmental Technology Program. The Chief Project Officer was Tom Brady, Spokane Research Center.

The geographical area included in this handbook (Powder River-Fort Union) is illustrated by the map below.

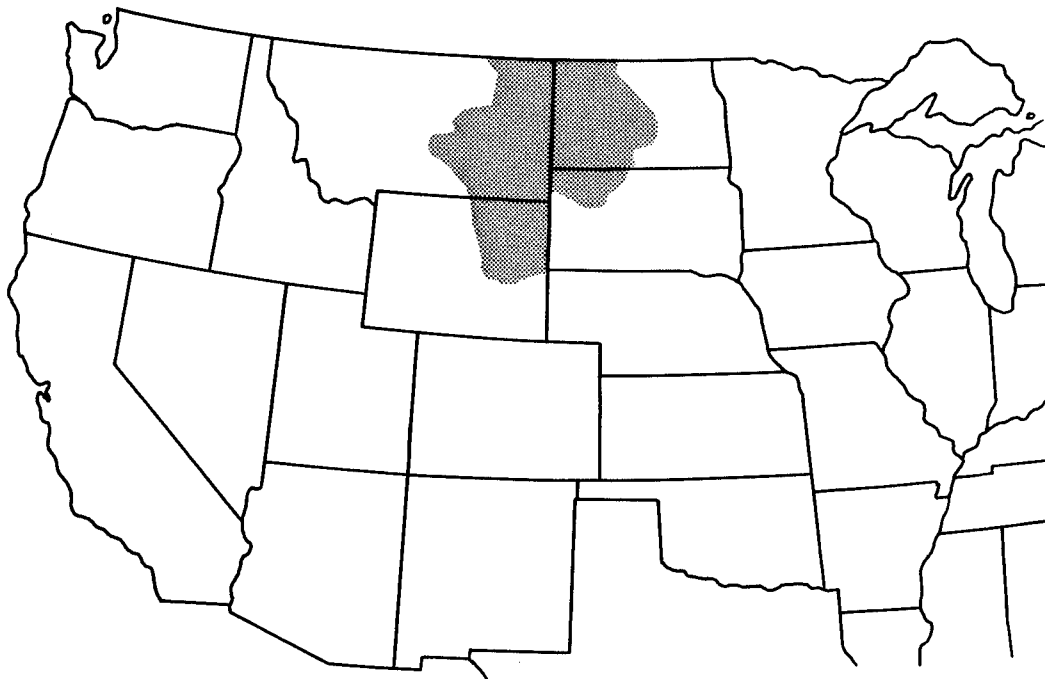

CONTENTS

	<u>Page</u>
PREFACE.....	iii
FIGURES.....	vii
TABLES.....	x
1. INTRODUCTION.....	1
1.1 Use of the Handbook.....	1
1.2 Factors Affecting Protection and Enhancement Practices.....	3
2. PLANNING.....	5
2.1 Fish and Wildlife Needs.....	5
2.1.1 Golden Eagle.....	5
2.2.2 Sage Grouse.....	6
2.2.3 Sharp-tailed Grouse.....	6
2.2.4 Turkey.....	6
2.2.5 Waterfowl.....	6
2.2.6 Raptors.....	7
2.2.7 Nongame Birds.....	7
2.2.8 Mule Deer.....	7
2.2.9 White-tailed Deer.....	7
2.2.10 Elk.....	8
2.2.11 Pronghorn.....	8
2.2.12 Cottontails and Jackrabbits.....	8
2.2.13 Small Furbearers.....	8
2.2.14 Wild Canids.....	9
2.2.15 Prairie Dogs.....	9
2.2.16 Endangered Species.....	9
2.2 Management for Fish and Wildlife.....	11
3. BEST CURRENT FISH AND WILDLIFE ENHANCEMENT/PROTECTION PRACTICES...	13
3.1 Premining Practices Used to Enhance and/or Protect Fish and Wildlife Resources.....	13
3.1.1 Design, Location, and Construction.....	13
a. Roads.....	13
b. Powerlines.....	18
c. Stream Crossings.....	24
d. Fences.....	28
3.1.2 Habitat Improvement on Adjacent Areas to Increase Carrying Capacity.....	36

CONTENTS (continued).

	<u>Page</u>
3.2 Practices Used During Mining to Enhance and/or Protect Fish and Wildlife Resources.....	41
3.2.1 Overburden and Soil Handling.....	41
a. General Procedures.....	41
b. Selective Placement of Spoils and Topsoil.....	43
c. Use of Mycorrhizae to Enhance the Establishment of Woody Plants for Wildlife Food and Cover.....	47
3.2.2 Wildlife Habitat Improvement and Development.....	51
a. Establishment of Buffer Zones.....	51
b. Rights-of-Way Management for Wildlife.....	54
3.3 Practices or Reclamation Techniques Used to Enhance and/or Protect Fish and Wildlife Resources.....	57
3.3.1 Revegetation.....	57
a. Use of the Plant Information Network (PIN) to Aid in Selection of Revegetation Plants.....	57
b. Fertilization.....	64
c. Seeding.....	69
d. Transplanting Native Vegetation.....	75
e. Transplanting Nursery Grown Plants.....	83
f. Cover Crops/Preparatory Crops.....	90
g. Water Conservation.....	93
h. Mulching.....	99
i. Irrigation.....	104
j. Pest Control.....	113
k. Grazing Management to Allow Vegetation Recovery.....	119
3.3.2 Water Resource Improvement and Development.....	123
a. Final Cut Lakes as Permanent Impoundments.....	123
b. Supplementary Water Resources.....	124
c. Creating Impoundments for Waterfowl.....	129
d. Island Development for Waterfowl.....	133
e. Creating Impoundments for Fish.....	137
f. Stocking Impoundments with Fish.....	142
g. Streambank Protection-Gabion Matting and Riprap.....	146
3.3.3 Wildlife Habitat Improvement and Development.....	151
a. Creating Topographic Features.....	151
b. Planting Patterns to Increase Wildlife Diversity.....	156
c. Creating Wind and Snowbreaks for Winter Wildlife Protection.....	160
d. Rock Piles.....	167
e. Brush Piles.....	170
f. Construction of Nesting Structures for Birds.....	173
g. Building Alternative Nest Sites for Golden Eagles.....	182

CONTENTS (concluded).

	<u>Page</u>
h. Maintenance of Sage Grouse and Sharp-tailed Grouse Habitats.....	186
i. Restoring Big Game Range.....	193
4 REGIONAL RECLAMATION PLAN.....	200
4.1 Introduction.....	200
4.1.1 Woody Draws.....	204
4.1.2 Ponderosa Pine Woodlands.....	205
4.1.3 Cottonwood Drainages.....	206
4.2 Regrading.....	206
4.3 Stream Restoration.....	210
4.4 Soil and Seedbed Preparation.....	210
4.5 Revegetation and Management.....	210
4.5.1 Cottonwood Drainages.....	210
a. Planting.....	212
4.5.2 Woody Draws.....	213
a. Species Selection.....	213
b. Seeding.....	213
c. Planting Techniques.....	213
d. Planting Rate and Timing.....	225
e. Weed Control.....	225
f. Water Harvesting.....	225
4.5.3 Ponderosa Pine Woodlands.....	225
a. Seeding - Preparatory Crops and Perennials.....	225
b. Seedling Source.....	225
c. Planting Bare Root Stock.....	226
d. Mulch and Weed Control.....	226
e. Irrigation.....	226
f. Planting Mature Vegetation.....	226
g. Animal Damage Control.....	226
4.6 Additional Enhancement for Wildlife.....	227
4.6.1 Brushpiles and Rock Piles.....	227
4.6.2 Nest Boxes.....	227
4.6.3 Access Restriction.....	227
4.7 References.....	227
Appendixes	
A. Sources of Information.....	229
Montana.....	229
North Dakota.....	232
Wyoming.....	235
B. Names of Plants Mentioned in the Text.....	240
C. Names of Animals Mentioned in the Text.....	244

FIGURES

<u>Number</u>		<u>Page</u>
3.1-1	Sight distance on vertical curves.....	15
3.1-2	Sight distance on horizontal curves.....	15
3.1-3	Vertical separation of the center and two outside conductors precludes the electrocution hazard on one type of pole.....	19
3.1-4	Artificial perches mounted above existing poles as an alternative to pole modification and perch assembly details.....	20
3.1-5	Protective conductor insulation cover for installation on poles used by raptors as an alternative to pole reconstruction.....	21
3.1-6	The arch culvert provides for fish passage.....	26
3.1-7	Fence types including cattle tight, sheep tight, cattle-sheep tight, and cattle-horse tight where deer, elk, and moose are present.....	29
3.1-8	Woven wire fencing on antelope range including tall sheep tight and cattle-horse tight where deer, elk, and moose are present and sheep are absent.....	30
3.1-9	Fencing layouts for preventing corner pile-up during blizzards and for directing animals around reclaimed or hazardous areas.....	31
3.1-10	Antelope passes utilizing cattleguards on woven-wire, sheep tight and barbed wire, cattle tight fencing.....	33
3.1-11	Chaining to improve wildlife habitat.....	38
3.1-12	Vegetative buffer zones to protect stream water quality.....	52
3.3-1	Tree spade and transporter.....	77
3.3-2	Front end loader and transplant bucket.....	78

FIGURES (continued).

<u>Number</u>		<u>Page</u>
3.3-3	Tractor-drawn modified Hodder gouger.....	95
3.3-4	Manifold detail.....	108
3.3-5	Solid set irrigation system on mined site.....	109
3.3-6	Artist's representation of a solid set irrigation system operating on a reclaimed mine site.....	110
3.3-7	Aerial view of an island created for waterfowl on a surface mine reservoir.....	133
3.3-8	Schematic showing possible areas of earth removal and areas of placement to create postimpoundment islands.....	134
3.3-9	Earthen-mound islands can easily be constructed with a bull- dozer during impoundment construction.....	135
3.3-10	Stream cross section showing the use of gabion mats on a sloping streambank.....	148
3.3-11	Placement of stone gabion to protect a streambank.....	148
3.3-12	Use of riprap to protect a streambank from erosion.....	149
3.3-13	Contouring to create wildlife habitat.....	152
3.3-14	Windbreak effect of land contouring.....	153
3.3-15	Contouring to create waterholes and simulate a rimrock habitat.....	155
3.3-16	Comparison of diversity indices for various geometrical shapes all with an area of 0.4 ha.....	157
3.3-17	Suggested wildlife planting for an open area.....	161
3.3-18	Multirow wildlife plantings with single species planted in blocks.....	162
3.3-19	Suggested design for large multirow wildlife plantings.....	163
3.3-20	A rock pile for use by amphibians and reptiles.....	168

FIGURES (concluded).

<u>Number</u>		<u>Page</u>
3.3-21	Construction of brush pile shelters demonstrating base construction methods and construction with dead brush.....	170
3.3-22	Diagram of artificial raptor nest platform with sunshade and perch mounted on utility pole.....	175
3.3-23	Finished tripod apex with attachments.....	177
3.3-24	Overview of raptor nesting tripod.....	177
3.3-25	Installation and operation of artificial burrowing owl nest burrows.....	179
3.3-26	Male sage grouse on strutting ground.....	187
4.1-1	Premining topography of the Porcupine Mine Site.....	201
4.1-2	Premining soils on the Porcupine Mine Site.....	202
4.1-3	Premining vegetation on the Porcupine Mine Site.....	203
4.2-1	Recontoured topography of the Porcupine Mine Site.....	207
4.2-2	Postmining vegetation on the Porcupine Mine Site.....	208
4.2-3	Proposed reclamation sequence at the Porcupine Mine Site.....	209

TABLES

<u>Number</u>		<u>Page</u>
3.3-1	List of descriptor and descriptor states under the general heading of "Economic Attributes" in the PIN data bank.....	58
3.3-2	Possible revegetation species for livestock forage on sandy soils in Campbell County, Wyoming.....	60
3.3-3	Seeding methods - advantages and disadvantages.....	70
3.3-4	Projected costs required to reestablish shrub densities on surface mined lands in northwestern Colorado.....	81
3.3-5	Comparison of seeding and transplanting nursery grown stock..	83
3.3-6	Comparison of nursery grown planting stocks.....	84
3.3-7	Cost required to establish one surviving nursery transplant..	87
3.3-8	Comparative cost of preparatory crops and crimped straw mulch.....	91
3.3-9	Advantages and disadvantages of surface manipulation techniques.....	96
3.3-10	Advantages and disadvantages of different types of mulches...	100
3.3-11	Advantages and disadvantages of drip and sprinkler irrigation systems.....	105
3.3-12	Nest box dimensions and placement height.....	174
4.5-1	Streamside seed mixture.....	211
4.5-2	Streamside seedling transplant mixture.....	211
4.5-3	Species to be used in the initial seeding and soil stabilization process for side slopes and secondary drainages.....	214
4.5-4	Adaptation matrix for species to be used in the initial seeding and soil stabilization process of side slopes and secondary drainages.....	215

TABLES (conclude).

<u>Number</u>		<u>Page</u>
4.5-5	Species to be used in the initial seeding and soil stabilization process for primary drainages.....	218
4.5-6	Adaptation matrix for species to be used in the initial seeding and soil stabilization process of primary drainages.....	219
4.5-7	Species selected for woodland revegetation.....	222

1. INTRODUCTION

Numerous techniques and methods are being used during surface mining and reclamation operations throughout the country to minimize disturbances and adverse impacts to fish and wildlife. Some of these methods are accepted or recognized as state-of-the-art technology; whereas others may be outdated or even detrimental. This handbook is written as a "first approximation" of design specifications, to document effective field techniques being used and to highlight sources of information for techniques that are now in use. This review will also consider equipment, devices, systems, and methods that have been useful in special cases. At a later date and as more information becomes available, this handbook will be revised and updated to reflect the best current practices state-of-the-art.

To facilitate the transfer of information, the term "Best Current Practices" (BCP) has been used to present field techniques that have been successful, or that show definite promise of being successful, on surface-mined land. The Surface Mining Control and Reclamation Act of 1977 states that "to the extent possible using the best technology currently available (BTCA), [the operator is required to] minimize disturbances and adverse impacts of the operation on fish, wildlife, and related environmental values, and achieve enhancement of such resources where practicable" (Section 515 [b] [24]). Furthermore, THE SURFACE COAL MINING AND RECLAMATION OPERATIONS PERMANENT REGULATORY PROGRAM STATES THAT "WITHIN THE CONSTRAINTS OF THE PERMANENT PROGRAM, THE REGULATORY AUTHORITY SHALL HAVE THE DISCRETION TO DETERMINE THE BEST TECHNOLOGY CURRENTLY AVAILABLE (BTCA) ON A CASE-BY-CASE BASIS" (Section 701.5). The BCP's presented in this handbook are being offered as guidelines to the mining community and regulatory agencies for use not only when an environmental problem arises, but also when an operator wishes to initiate a wildlife management program.

IN ALL CASES, THE BCP'S IN THIS HANDBOOK, THAT ARE SELECTED FOR USE ON A PARTICULAR SITE, MUST BE APPROVED FOR USE BY THE STATE REGULATORY AUTHORITY. IN SOME INSTANCES, A BCP MAY NOT CONFORM TO THE LATEST STATE REGULATORY PROGRAM.

1.1 USE OF THE HANDBOOK

This handbook is one of several guides being developed by the U.S. Fish and Wildlife Service to aid mid-level managers, field inspectors, and mine reclamation specialists in the coal regions. Its purpose is to identify the points at which fish and wildlife resources can be protected and enhanced during the various phases of mine development and reclamation on a regional basis. Some of the techniques and practices are applicable to more than one geographic region; others are region-specific.

The handbook has been arranged to include a section on the planning needs for fish and wildlife resources during the mining process. Regional problems are identified, and the specific needs that individual sites would have are highlighted. Planning needs, such as baseline data gathering, site potential evaluation, fish and wildlife plan preparation, and reclamation planning are discussed.

BCP's for the protection and enhancement of fish and wildlife resources are presented in Section 3. The format for each BCP generally follows the topical outline below:

Purpose: The usefulness of each BCP is explained, giving its geographic and habitat applicability.

Development: The steps for implementing each BCP are given, emphasizing the relationship to postmining land uses and compatibility with other BCP's.

Maintenance and Management: Considerations for the long-term upkeep of some BCP's are stressed.

Labor and Materials: To give some idea of the cost of implementing a BCP, levels of effort are given in terms of man-hours, types of personnel, and dollar values (where costs could be estimated). Equipment and construction materials are itemized.

Sources of Information: For further assistance, the following information has been provided: the company or agency who used or proposed the BCP; government contacts; and useful literature, such as books, articles, publications, and studies. Addresses and phone numbers of the referenced agencies are listed in Appendix A.

Finally, in Section 4, a regional reclamation plan is given for specific habitat types in the Powder River-Fort Union Coal Region. Within a specific habitat type, appropriate BCP's are presented which are compatible with the terrain and indigenous fish and wildlife resources. These reclamation alternatives are designed to be used as an example of what could be done for fish and wildlife under a certain set of environmental conditions. As a guide, they offer ideas and suggestions to aid the operator with site-specific reclamation planning.

The BCP's described in this handbook were chosen because of their applicability to the Powder River-Fort Union Coal Region. Considerations in their choice included the habitats to be reclaimed, major fish and wildlife species in the area, the postmining land use, and the objectives of the reclamation plan.

With the above considerations in mind, the BCP's are somewhat regionally specific. However, many of the BCP's can also be used in other areas that have similar combinations of habitats, species, postmining land uses, and objectives in the reclamation plan.

1.2 FACTORS AFFECTING PROTECTION AND ENHANCEMENT PRACTICES

Large western surface coal mines often occur on a variety of parcels owned by Federal agencies (such as the U.S. Forest Service and the U.S. Bureau of Land Management), State lands, and privately owned lands. The lease for mineral rights may be obtained from one or all of these entities, depending on surface ownership.

Federal agencies require environmental studies prior to leasing and may exclude certain lands from leasing that are considered environmentally sensitive. Buffer zones may be required as part of the lease to protect a particularly sensitive area. No occupancy requirements may be imposed during certain seasons, for example, when sensitive bird species are nesting.

The operator, with leases secured, must obtain a permit to mine from the Federal Office of Surface Mining and the State regulatory authority. In most cases, the land is required to be returned to a condition capable of supporting the premining land use. In much of the Powder River-Fort Union Coal Region, the land is used for cattle grazing, and croplands are limited to irrigated river valleys. However, in North Dakota, the primary land use is agricultural cropland. Wildlife needs must be considered in the restoration of both of these types of land use.

The mine permit application and the review process is another chance to evaluate sensitive wildlife areas and propose ways of mitigating impacts. This is a critical time for close contact between the landowner (assuming private ownership) and mineral lessor to cooperate and agree on postmining land use plans. If the landowner does not want sediment ponds or wetlands remaining on his land, they will probably be removed following the performance bond release and will not provide lasting wildlife value. Perhaps the landowner will have suggestions for reclamation projects, such as shelter belts, which will improve the land for both livestock and wildlife. Both the mine operator and landowner can benefit from a mutually agreed-upon plan. The landowner can benefit from the recreational aspects of wildlife on his land, while the operator will profit from favorable public relations stemming from the maintenance of wildlife areas. Sport fishing and hunting is a big business, and development of areas conducive to this industry certainly provides a stimulus to the local economy.

A significant portion of the coal and/or surface land in this region is Federally owned. Where this is the case, the BLM and Forest Service will negotiate the mitigation measures to be employed. The State regulatory authority, guided by the state game and fish department and the U.S. Fish and Wildlife Service, will also have considerable input.

Ultimately, the question arises as to how much additional costs, if any, would be associated with providing protection and enhancement to fish and wildlife. Efforts were made to answer this question; however, costs will vary with the site-specific characteristics of a particular mine. With this knowledge, the operator should then seek the advice of the local surface mining regulatory authority, fish and wildlife agencies, and Soil Conservation Service officials, who can help "fine-tune" site-specific cost information. In most cases, overall costs will be minimal, and, as mentioned earlier, may actually save money. The final cost, however, will depend on the combination of techniques the operator and landowner wish to use to satisfy the postmining land use objective at their particular mine site.

2. PLANNING

2.1 FISH AND WILDLIFE NEEDS

Fish and wildlife have certain basic habitat needs which must be met. These needs include the presence of food, cover, and water within the home range of the animal. These elements also have to be arranged in a particular pattern to ensure accessibility. A successful reclamation plan to enhance fish and wildlife resources must consider all these factors. If one or more of the elements is missing or if they are unavailable, no amount of effort can achieve the desired enhancement objective. For example, pronghorn distribution is restricted by late summer water availability on many ranges. In Wyoming's Red Desert, 95% of 12,465 pronghorn observed were sited within a 4.8- to 6.4-km (3- to 4-mi) radius of a water source. Adjacent, suitable areas lacking water sources received low utilization. Utilization of these adjacent ranges could be greatly improved if water sources (the deficient habitat requirement) were more evenly distributed (in this case, every 4 to 5 km [2.5 to 3.1 mi]), or if supplementary wells were provided.

Not all animals have the same habitat requirements. In fact, even closely related species may have important differences in habitat needs. These differences will ultimately determine the success or failure of the reclamation plan. General discussions on the habitat requirements of selected species in the Powder River-Fort Union Coal Region follow.

2.1.1 Golden Eagle

Golden eagles are often found where escarpments or large trees are available for nesting or roosting and open areas provide adequate hunting habitat. The home range of a pair of golden eagles is about 90 km² (35 mi²). Breeding pairs may use the same nest every year; others use alternate nests in successive years; and some apparently nest only every other year. The same nest site may be used by succeeding generations of eagles. Eagles eat jackrabbits, snakes, ground squirrels, prairie dogs, and some birds, such as magpies and pigeons. Carrion also constitutes a substantial portion of the eagle's diet. In coal mine areas, increased traffic results in more frequent road kills and, therefore, an elevated prey base. However, traffic also presents a hazard to eagles feeding on carrion along roads. Many eagles are electrocuted every year while landing on, or flying from, high-voltage power lines. Golden eagles, their nests, young, and eggs are protected from disturbance by Federal law. Additional information is provided in Section 3.3.3.g, Building Alternative Nest Sites for Golden Eagles.

2.2.2 Sage Grouse

As their name implies, sage grouse are closely associated with sagebrush. Sagebrush densities of 20 to 40% are considered optimum, particularly if the distribution is patchy. They are completely dependent on sagebrush for food from October through April. Summer food is mostly forbs, although young sage grouse feed on insects. Sage grouse require open areas (0.1 to 0.2 ha [0.2 to 0.5 acres]) for strutting grounds (leks) in the spring. A majority of sage grouse nests are found within a 2.4 km (1.5 mi) radius of the lek. Nesting habitat should have a sagebrush density of 20 to 40%, and heights should vary between 17 and 79 cm (6.6 and 30.8 in). Wintering areas may be nearby or several kilometers distant. The habitat selected depends on severity of winter weather, local topography, and vegetative cover. Additional habitat requirements and relationships are provided in Section 3.3.3.h, Maintenance of Sage Grouse and Sharp-tailed Grouse Habitats.

2.2.3 Sharp-tailed Grouse

Sharp-tailed grouse thrive on early successional vegetation. Strutting grounds are found on ridges surrounded by grassy terrain. Nest sites are usually located in grassy uplands in the taller vegetation. Shade provided by shrubs or tall grasses is essential for brood rearing. (For a list of habitat and vegetation requirements, see Section 3.3.3.h, Maintenance of Sage Grouse and Sharp-tailed Grouse Habitats.) In winter, sharptails seek out brushy draws or brushy, riparian bottoms where dried-up berries and rose hips are available for food. Sharptails sometimes burrow under the snow for cover. The winter daily cruising radius is about 1.6 km (1 mi).

2.2.4 Turkey

The wild turkey prefer pine-oak scrub, ponderosa pine, and riparian forest habitats in eastern and northern Wyoming, and in similar adjacent habitats in Montana and South Dakota. Turkeys roost in trees at night. The male has a harem comprised of several females. Following the breeding season, there is a segregation of the sexes. Turkeys are rarely found more than 3 km (2 mi) from water. Food includes seeds, wild fruits, and a wide variety of insects. Most coal mines in the region are not in areas of turkey habitat.

2.2.5 Waterfowl

Blue-winged teal, mallard, pintail, American wigeon, gadwall, northern shoveler, green-winged teal, cinnamon teal, redhead, lesser scaup, canvasback, ruddy duck, and Canada geese are the most common waterfowl species breeding and rearing their young in the Powder River-Fort Union Coal Region. Other species occur frequently, particularly in the pothole regions of North Dakota. Most common are the first five species listed above. All five are dabbling ducks and require shallow water areas (0.6 m [2 ft] or less) to feed. Small, irregularly shaped ponds with emergent vegetation and islands provide areas for courtship, nesting, and brood rearing.

2.2.6 Raptors

In the Powder River-Fort Union Coal Region, the most common raptors are the sparrow hawk, Swainson's hawk, red-tailed hawk, ferruginous hawk, and golden eagle. All inhabit open, rolling hills characteristic of the region. Prey range from insects for the sparrow hawk to rodents, jackrabbits, and carrion for the larger species. Nest sites include the cavities of trees, abandoned buildings, or magpie nests (sparrow hawk); the ground (marsh hawk); or on cliffs, knolls, or in isolated trees (ferruginous hawk, golden eagle). Most are intolerant of human disturbance which may lead to the abandonment of the nest and/or young.

2.2.7 Nongame Birds

Nongame birds associated with grasslands and sagebrush habitats include meadowlarks, horned larks, longspurs, lark buntings, and a variety of sparrows, such as vesper sparrows. Woody draws and riparian areas provide food and/or cover for owls, hawks, woodpeckers, swallows, warblers, vireos, and towhees. Potholes, small stock ponds, and wetlands attract many species of waterfowl, blackbirds, and shorebirds. Rocky outcrops provide important habitat for raptors, swallows, and rock wrens.

2.2.8 Mule Deer

Mule deer are found in the Powder River-Fort Union Coal Region where the occasional escarpments, buttes, draws, and stream bottoms provide adequate forage and cover. In general, three conditions are important for good mule deer habitat: (1) early stages of plant succession are more beneficial than climax vegetation; (2) a mixture of plant communities provides better habitat than any single community (this is true for most wildlife); and (3) more browse species are preferable. Mule deer can adapt to a wide range of forage types. Browse, particularly sagebrush, is essential on winter ranges. This is not true because sagebrush is highly palatable or desirable to mule deer but because oftentimes it is the only palatable shrub available on ranches heavily used by livestock. The spatial distribution of mule deer habitat requirements is discussed in Section 3.3.3.i, Restoring Big Game Range.

2.2.9 White-tailed Deer

White-tailed deer are less common than mule deer, although they are found throughout the Powder River-Fort Union Coal Region in suitable habitats. This species is most common in the North Dakota portion of this coal region. They prefer coniferous forests and riparian forests with dense deciduous understory. These habitats are similar to those of the mule deer and, in some areas, the two species crossbreed; however, the whitetail usually prefers denser forests. Like the mule deer, food habits reflect the availability of different forage species in an area.

2.2.10 Elk

Elk are uncommon in the Powder River-Fort Union Coal Region. They occupy semiopen forests, mountain meadows (in summer), foothills, and valleys. Elk summer in the mountains or foothills and descend to the more protected lowlands for the winter. They forage primarily on grasses; however, in some areas, forbs comprise the major portion of the summer diet. Shrubs are more important during winter.

2.2.11 Pronghorn

Pronghorn occupy areas typified by low, rolling, wide-open, expansive terrain. Small herds may occupy ranges with sparse stands of ponderosa pine or juniper. Most pronghorn are found within 4.8 to 6.4 km (3 to 4 mi) of water (Sundstrom 1968). Pronghorn prefer succulent plants and thrive best on rangeland with a variety of shrubs, forbs, and grasses. Sagebrush is essential winter forage and is particularly important for cover during the fawning season. Monotypic shrubs or grasslands are not favored pronghorn habitat. Optimum habitat contains 40 to 60% vegetative cover, consisting of 10 to 20% sagebrush, 5 to 15% other browse species, 25 to 35% forbs, and 40 to 60% grass. (For a list of some important forage species, see Section 3.3.3.i, Restoring Big Game Range.) Winter herd concentrations often number 200 to 1,000. When spring approaches, dominant males establish territories with small bands of does, yearlings, and fawns. The range of a pronghorn herd is usually 8 to 16 km (5 to 10 mi) in diameter.

2.2.12 Cottontails and Jackrabbits

Whitetailed jackrabbits and cottontails inhabit the Powder River-Fort Union region. These species are active year-round and are primarily nocturnal, although they may be seen at any time during the day. Jackrabbits rest above ground in depressions which they construct at the bases of larger plants. Cottontails seek refuge in shrubs, rocks, or burrows. Both jackrabbits and cottontails feed on grasses and forbs; shrubs are consumed in winter. The home range for cottontails extends from 0.4 ha (1 acre) for females to 6 ha (15 acres) for males. Cottontails and jackrabbits serve as prey for many species of animals, including eagles, hawks, fox, coyotes, owls, and weasels.

2.2.13 Small Furbearers

Raccoons, skunks, long-tailed weasels, mink, and badgers are common furbearers in the Powder River-Fort Union Coal Region. All of these species eat a wide variety of foods. Weasels and badgers seek small mammals, such as mice and ground squirrels. Mink consume a variety of reptiles, amphibians, fish, and invertebrates associated with stream courses. Raccoons and skunks are omnivores and eat large amounts of plant materials, such as corn and fruit, as well as animals and invertebrates, such as crayfish, birds, insects, and small mammals. Badgers inhabit the open prairie where numerous burrowing rodents are available as food. Raccoons, skunks, and weasels require some type of denning cover, such as rocks, brush piles, or hollow logs. A stream or creek

is essential habitat for mink. These furbearers are valuable because of the number of small mammals they consume, but they can also reduce waterfowl nesting success where nesting habitat is easily hunted.

2.2.14 Wild Canids

The major wild canid in the Powder River-Fort Union Coal Region is the coyote; swift foxes and red fox also occur. Coyotes prey upon the entire range of small mammals, as well as game birds, waterfowl, reptiles, fish, and occasionally domestic livestock. Coyote dens are usually underground, beneath the roots of larger trees, or dug into a hill or gully. Coyotes are extremely adaptable and are able to survive on the plains if prey and water are available. Swift fox dig holes for dens and eat small mammals, small birds, reptiles, amphibians, and insects. Red fox may be found in a mixture of forests and open country, and agricultural land associated with river bottoms. In Montana and North Dakota, several red fox inhabited spoils and overburden stockpiles associated with sediment ponds of some mines.

2.2.15 Prairie Dogs

Prairie dogs are burrow-dwelling, colonial rodents which can be seen aboveground much of the year. Most of the time aboveground is spent feeding on grasses and annual forbs. During late fall, winter, and early spring, prairie dogs frequently dig and eat roots of forbs and grasses. Prairie dogs are social animals and live in "towns" which may cover dozens of hectares. Burrowing owls often use prairie dog burrows and can be seen during the day capturing insects. Prairie dog towns are essential habitat of the endangered black-footed ferret. Several ferrets have been sighted recently (November 1981) near Meeteetse, WY.

2.2.16 Endangered Species

There are a few species of plants and animals which are presently in danger of becoming extinct or eliminated from an area because of loss of suitable habitat. These species often have very special needs which are met only under certain environmental conditions in a few restricted geographic areas. For this reason, they are highly susceptible to changes in their habitat. The Federal Endangered Species Act protects many of these species while, in other cases, State regulations are in effect. If it is determined that one of those species occurs on a mine site, the State regulatory authority should be informed of its presence. This will enable the proper authorities to evaluate the impact of mining on the species and to take the steps necessary to minimize the impact.

The endangered species of concern to mine operators in this region is the bald eagle. The Gillette and Sheridan, WY, areas are inhabited by conspicuous winter populations which are much larger than the breeding populations (Dorn 1979). Occasionally, bald eagles may be seen flying over any of the coal mines in Campbell County, Wyoming. There is a winter roost approximately 3 km (2 mi) south of the Caballo Rojo Mine (Oakleaf et al. 1979; M. Lockhardt, personal communication, U.S. Fish and Wildlife Service, Sheridan; W. Gasson, personal communication, Wyoming Game and Fish Department, Gillette). The

peregrine falcon has a range encompassing this region, but probably utilizes the area only during migration. Black-footed ferrets are known from this region, but none have been reported recently (Weaver and Clark 1979). However, ferrets are not extinct and may occur in the region if the habitat is adequate. On 29 October 1981, a black-footed ferret was trapped, radio-collared, and released on a ranch west of Meeteetse, WY. This was the first confirmed sighting of a live ferret in the United States since a 1974 sighting in South Dakota. Several different individuals have been seen in the area since late October 1981. Ferrets feed primarily on prairie dogs and use their burrows for denning and shelter.

Endangered species are fully protected under the Endangered Species Act of 1973, Public Law 93-205, and may be protected under other Federal (Bald Eagle Protection Act of 1969, 16 USC 668, and Migratory Bird Treaties, 16 USC 703, 50 CFR 20.71) and State laws. Operators should contact the U.S. Fish and Wildlife Service if they suspect a Federally endangered species is inhabiting their lease.

2.2 MANAGEMENT FOR FISH AND WILDLIFE

Restoration of fish and wildlife habitat is a viable part of the surface mining process which can provide long-term benefits to the landowner and society in general. This is an important part of the mining process and should be integrated into all planning phases.

Long-range planning is necessary because the benefits from managing for fish and wildlife continue beyond the reclamation bonding period. For example, management for sage grouse, as mentioned above, would be a long-term goal over several years, realized only after sagebrush stands and other habitat needs were fully established on the site. In addition, some continued maintenance of the various vegetation phases may be necessary to retain the best habitat for a selected species. Thus, planning for wildlife should begin in the premining planning phase and should include consultation with appropriate Federal and State agencies.

Certain considerations are necessary to accomplish effective long-range planning that allows for full development of fish and wildlife in the reclamation plan. These considerations include:

- o existing data compilation to determine if and what baseline data are needed;
- o baseline data gathering;
- o site potential evaluation;
- o discussions with the postmining landowner;
- o goal-setting;
- o reclamation planning; and
- o fish and wildlife planning.

The baseline data provides the working foundation for effective management planning. Most of the information gathered in the permitting process can be used to help protect and enhance fish and wildlife resources. After the land use/cover types, wildlife habitat types, aquatic resources, types of fish and wildlife inhabiting the area, and unique habitat or other biological features have been determined, planning can be more responsive to fish and wildlife needs.

Knowledge of the premining site characteristics will provide the basis for determining the potential for fish and wildlife management. The success of species inhabiting the area provides insight into the potential success of managing selected species. The characteristics of the areas around the mine site will indicate the potential for selected species management on the site, particularly in cases where species home ranges extend beyond the reclaimed area.

Based on the site characteristics and the site potential, realistic goals may be set for managing fish and wildlife. It is critical at this time to consult with the postmining landowner so that the proposed reclamation and wildlife enhancement practices will be compatible with the landowner's goals. Creating a wetland that will be converted by a private landowner to grazing or agricultural land shortly after bond release will not provide long-term value to wildlife, nor will it be cost-effective for the mining company. This concept is discussed further in Section 1.2, Factors Affecting Protection and Enhancement Practices. With the knowledge of baseline characteristics and site potential, a wildlife biologist can effectively incorporate fish and wildlife needs into the goals set for postmining land use. For example, green belts may be interspersed in residential/commercial areas; buffer zones, wind breaks, hedgerows, food plots, and other vegetation patches, as well as impoundments, may be incorporated into grazing land, forest land, and agricultural land or other multiple land use alternatives. Areas dedicated solely for use by fish and wildlife are viable and quite reasonable goals.

Reclamation and planning for fish and wildlife should be coordinated, whether the proposed postmining land use is solely for fish and wildlife or for some multiple use. After the goals are set, specific measures may be taken to apply the best current technology or practices to achieve fish and wildlife enhancement. Federal and State agencies are required to assist in planning and developing fish and wildlife habitat. Some State regulatory authorities and Office of Surface Mining offices have staff biologists experienced in mining technology, as well as wildlife and fisheries management. Other agencies, such as the Soil Conservation Service, State wildlife agency, State forestry service, State reclamation service, the U.S. Fish and Wildlife Service, and the Federal and State regulatory authority can provide additional guidance in planning and implementing procedures best suited to a particular site. Publications such as this one and others mentioned throughout this handbook can provide additional guidance.

References cited:

- Dorn, J. L. Birds. Pages 57-62 in Clark, T. W.; Dorn, R. D. eds. Rare and endangered vascular plants and vertebrates of Wyoming; 1979.
- Oakleaf, B.; Downing, H.; Raynes, B.; Raynes, M.; Scott, O. Wyoming Avian Atlas. Wyoming Game and Fish Department; 1979.
- Sundstrom, C. Water consumption by pronghorn antelope and distribution related to water in Wyoming's Red Desert. Proc. Antelope States Workshop. 3:39-46; 1968.
- Weaver, J. L.; Clark, T. W. Mammals. Pages 63-76 in Clark, T. W.; Dorn, R. D. eds. Rare and endangered vascular plants and vertebrates of Wyoming; 1979.

3. BEST CURRENT FISH AND WILDLIFE ENHANCEMENT/PROTECTION PRACTICES

3.1 PREMINING PRACTICES USED TO ENHANCE AND/OR PROTECT FISH AND WILDLIFE RESOURCES

This group of BCP's is designed to allow the operator to initiate measures to protect wildlife in the design phase of mine development. An additional BCP is provided which can assist the operator in the mitigation of habitat losses by improving the carrying capacity of areas adjacent to the proposed mine. Wildlife displaced from the mined area can move into acceptable habitat. All mitigation should be coordinated with the State regulatory authority.

3.1.1 Design, Location, and Construction

a. Roads.

PURPOSE

Consideration of fish and wildlife in the design and construction of access and haul roads can greatly reduce impacts to animal life. Loss of habitat, disturbance from vehicles, creation of barriers to wildlife travel, and other negative impacts can be reduced by proper road location, design, construction, and timing to avoid biologically sensitive periods, such as the nesting season. In most instances, there is minimal direct danger to wildlife from vehicle collisions. However, where this is a problem, the following techniques, coupled with a reduction of speed, will minimize the problem.

DEVELOPMENT

Many standards and specifications concerning the design and construction of roads are included in Federal and State surface mining regulations. These requirements, along with other engineering aspects dictated by site-specific conditions, must be given first consideration when designing and constructing roads. However, Federal and State regulations are being abandoned in favor of professional engineering, design, and construction standards whose specifications are applied on a more site-specific basis. Most considerations given fish and wildlife during road development can be initiated during road location and design. Management practices for sedimentation and siltation control are required by the Surface Mining Control and Reclamation Act of 1977 and are extremely important for protection of fish and water resources. Best current practices for stream crossings (Section 3.1.1.c), use of buffer zones (Section 3.2.2.a), fencing (Section 3.1.4), and rights-of-way management (Section 3.2.2.b) are discussed in separate sections.

When possible, locate roads below ridgelines. This tends to confine any wildlife disturbance created by traffic to one side of the ridge (Thomas 1979). The benefits to be realized in the limiting of disturbance to wildlife must be carefully considered against the additional disturbance caused by having to cut roads into hillsides. Loose dirt cut from the roadway would be pushed downslope, causing additional disturbance in terms of loss of vegetation and siltation. Designing roads with minimum rights-of-way reduces habitat destruction and can also reduce construction costs. Areas of high quality or important habitat should be avoided; specifically, roads shouldn't pass through important nesting or reproduction areas. Wetlands (e.g., marshes, riparian zones) are important wildlife habitat and should be avoided.

Roads sometimes are barriers to animal movements and should not cross important migration routes. The State department of fish and game can give advice on avoiding wildlife migration areas. If bisecting a deer migration route is unavoidable, underpasses should be provided for migrating animals, and the road should be fenced to guide the animals to the underpass (see Section 3.1.1.d, Fences). Underpasses are infrequently used by pronghorn and elk (Ward et al. 1976; Reed et al. 1980).

Sharp curves in roads should be avoided to reduce possible animal-vehicle collisions because of poor visibility. Where a curve is necessary, fences can be provided to keep animals from crossing the road at that point. Sighting distances for vehicle operators and wildlife can be improved by using a larger radius for horizontal and vertical curves and by increasing the right-of-way width on the inside of horizontal curves (Figures 3.1-1 and 3.1-2). This allows more avoidance time for drivers and more escape time for animals. One of the most effective means of reducing animal-vehicle collisions is simply to reduce speed limits on mine access roads.

Rights-of-way management practices, such as planting browse species that may attract wildlife, especially elk, deer, and pronghorn, should be avoided along roads with large volumes of high velocity traffic. This can help reduce direct mortality due to animal-vehicle collisions. Where roads are not approved for retention after mining, the roadbeds must be revegetated in accordance with State regulatory requirements. Unpalatable vegetation species should be planted along the road right-of-way to discourage grazing and further minimize potential highway mortality.

Some basic rules to follow in building roads that could affect permanent and intermittent streams are:

- o Do not remove gravel from stream beds.
- o Do not operate heavy equipment in any stream except for essential bridge or culvert installation.
- o Plan road construction so that sediment eroding from road cuts will not reach streams.

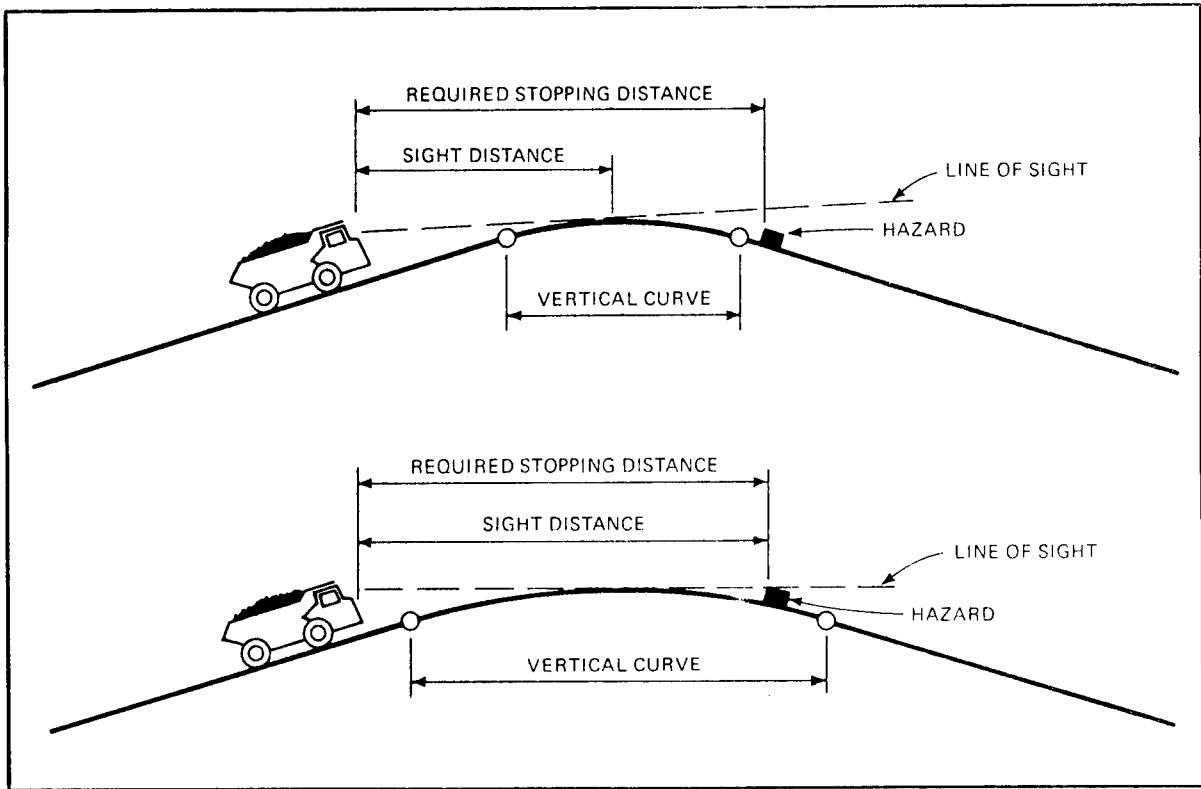

Figure 3.1-1. Sight distance on vertical curves (from Chironis 1978).

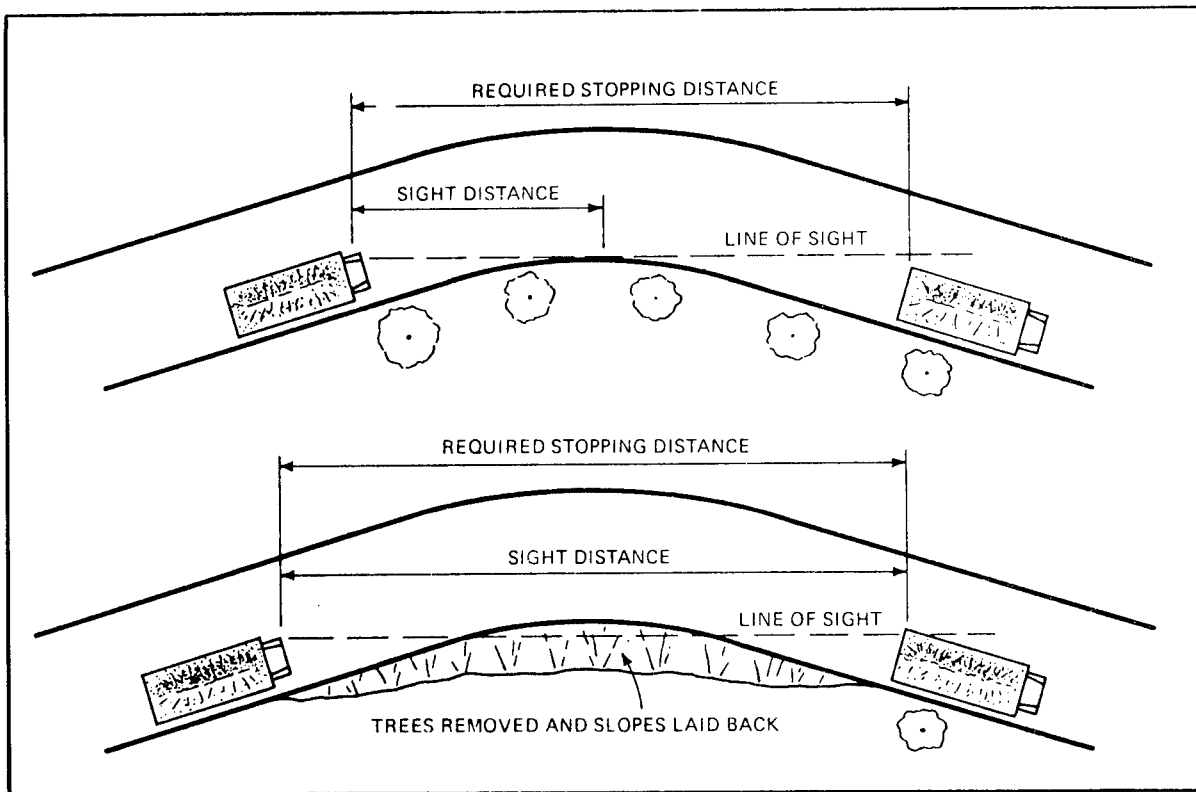

Figure 3.1-2. Sight distance on horizontal curves (from Chironis 1978).

- o Build roads in dry weather to reduce the potential for erosion materials to reach streams.
- o Make provisions to eliminate erosion and prevent drainage waters from entering streams.
- o Locate roads on natural benches and ridges well away from stream courses.

The Wyoming Department of Game and Fish (1976) recommends a minimum 152-m (500-ft) undisturbed buffer zone on both sides of large rivers and a 91-m (300-ft) buffer on smaller streams.

MAINTENANCE AND MANAGEMENT

Road design and construction techniques for fish and wildlife protection and enhancement generally do not require any maintenance beyond normal road maintenance. Structures that may require maintenance, such as culverts (Section 3.1.1.c), are addressed separately in this handbook (as well as Section 3.2.2.b, Rights-of-way Management).

LABOR/MATERIALS

Incorporation of fish and wildlife considerations in the road design is required during initial planning. Higher construction costs may be incurred while implementing some techniques, such as increasing a road's length when avoiding important habitat.

SOURCES OF INFORMATION

Information concerning the location and significance of the fish and wildlife resources within the permit area can be obtained from the fish and wildlife inventory prepared for the permit application. Additional planning information and technical assistance can be requested from:

- o State Regulatory Authority
- o Office of Surface Mining
- o State Game and Fish Agencies
- o State Department of Highways/Transportation
- o U.S. Fish and Wildlife Service
- o U.S. Forest Service

For addresses, see Appendix A.

References Cited:

Chironis, N. P., ed. Designing safer and speedier haul roads. In: Coal age operating handbook of coal surface mining and reclamation, vol. 2: McGraw-Hill, New York; 1978.

Reed, D. F.; Giunta, B. C.; Cebula, J. J.; Money, D. L.; Doose, C. A.; Merrell, C. L.; Dillinger, K. C.; Myers, G. T.; Zimmerman, W. B.; Fleming, J. D.; McDonnell, S. L.; Kincaid, K. R.; Pojar, T. M.; Woodard, T. N.; Beck, T. D. I. Deer vehicle accidents Statewide and methods and devices to reduce them. Proj. No. W-125-R. Colorado Division of Wildlife, Dept. Nat. Resour., Denver; 1980. 53 p.

Thomas, J. W., ed. Wildlife habitats in managed forests: The Blue Mountains of Oregon and Washington. Agriculture Handbook No. 553: U.S.D.A. Forest Service; published in cooperation with Wildlife Management Institute and U.S.D.I. Bureau of Land Management; 1979.

Ward, A. L.; Cupal, J. J.; Goodwin, G. A.; Morris, H. D. Effects of highway construction and use on big game populations. Rep. No. FHWA-RD-76-174. Fed. Highway Admin. Washington, DC; 1976. 92 p.

Wyoming Department of Game and Fish. Consideration for wildlife in industrial development and reclamation; 1976. 65 p.

Additional References:

Virginia State Water Control Board. Best management practices handbook: forestry. Planning Bulletin 317: Virginia State Water Control Board; 1979.

b. Powerlines.

PURPOSE

The design and construction of powerlines can significantly affect wildlife populations. Indirect impacts to wildlife occur from powerline design and management of the right-of-way. Direct impacts result from clearing, construction, and cleanup activities. Collisions, electrocutions, and entanglements are the principal causes of wildlife fatalities at powerline locations.

Several excellent publications are available to aid mine operators and other individuals responsible for planning and installing powerlines. Most newly installed powerlines are built to prevent injury or death of birds coming in contact with the lines. The information presented in this section is therefore brief and not intended to take the place of these other manuals. It is important, however, to highlight the design and construction concerns associated with powerlines and to emphasize their overall significance in planning.

DESIGN CONSIDERATIONS

- o In areas frequented by large birds (e.g. eagles and other raptors, herons, and pelicans), power poles are often used for hunting sites and feeding perches. Occasionally, birds are electrocuted when they contact two-phase conductors, or one-phase conductor and a ground wire while landing or taking off. On any given system, relatively inexpensive modifications can be made to highly frequented power poles that will greatly reduce mortality (Figures 3.1-3, 3.1-4, and 3.1-5) (see Ansell and Smith 1980).
- o Powerline routes should avoid open expanses of water and marshlands or waterways, which are used as flight lanes by migratory waterfowl and other birds. Areas heavily used for nesting, rearing, and roosting sites by wildlife should also be avoided. Areas where endangered or threatened species might be affected by the powerline construction and design should be avoided or appropriate mitigation must be considered. The local wildlife agency can advise appropriate measures. (Others are provided in BCP's, such as Section 3.1.2.a, Habitat Improvement on Adjacent Areas to Increase Carrying Capacity; Section 3.2.2.a, Establishment of Buffer Zones; and Section 3.2.2.b, Rights-of-Way Management for Wildlife.)

CONSTRUCTION CONSIDERATIONS

- o Access, construction, and maintenance roads should be located so erosion will be minimized. When possible, road grades and alignments should follow the contour of the land with smooth, gradual curves. If it is necessary to use heavy equipment along the path of the power poles, care should be taken to operate such equipment in a manner that does not result in stream degradation. Stringing line with helicopters can be done to avoid damage to other sensitive habitats and avoid road access.

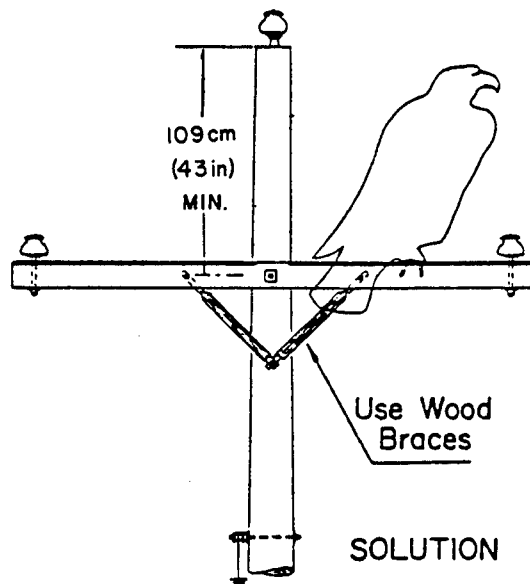
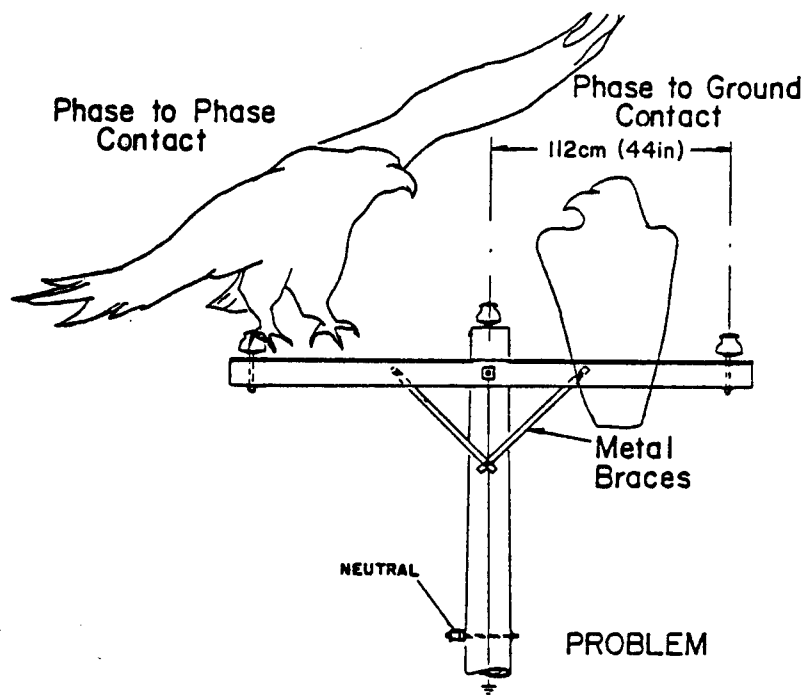
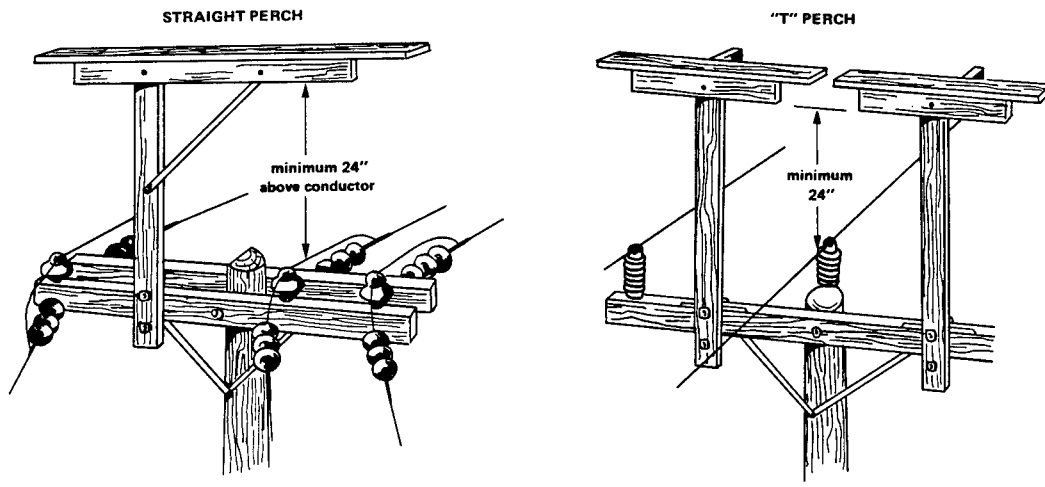

Figure 3.1-3. Vertical separation of the center and two outside conductors precludes the electrocution hazard on one type of pole (after Steenhof 1978).



TYPICAL PERCH APPLICATIONS

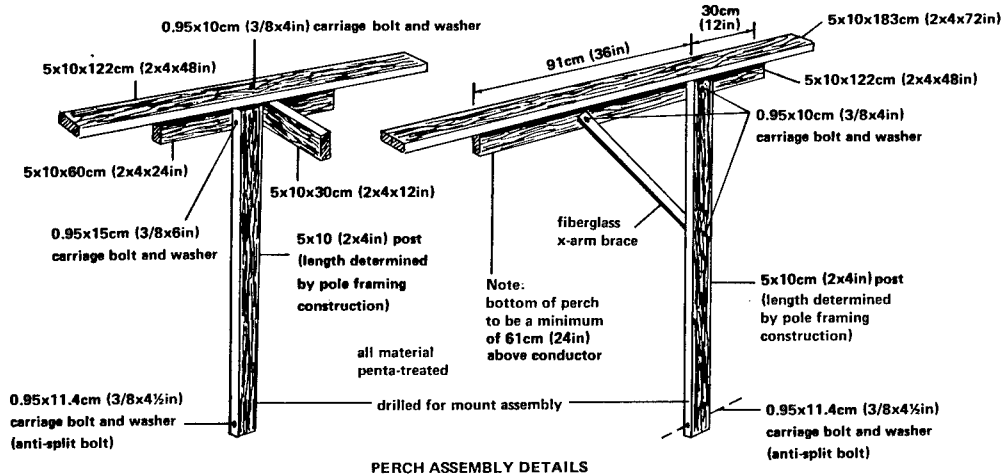

Figure 3.1-4. Artificial perches mounted above existing poles as an alternative to pole modification (suitable primarily for tree-less areas) and perch assembly details (after Ansell and Smith 1980).

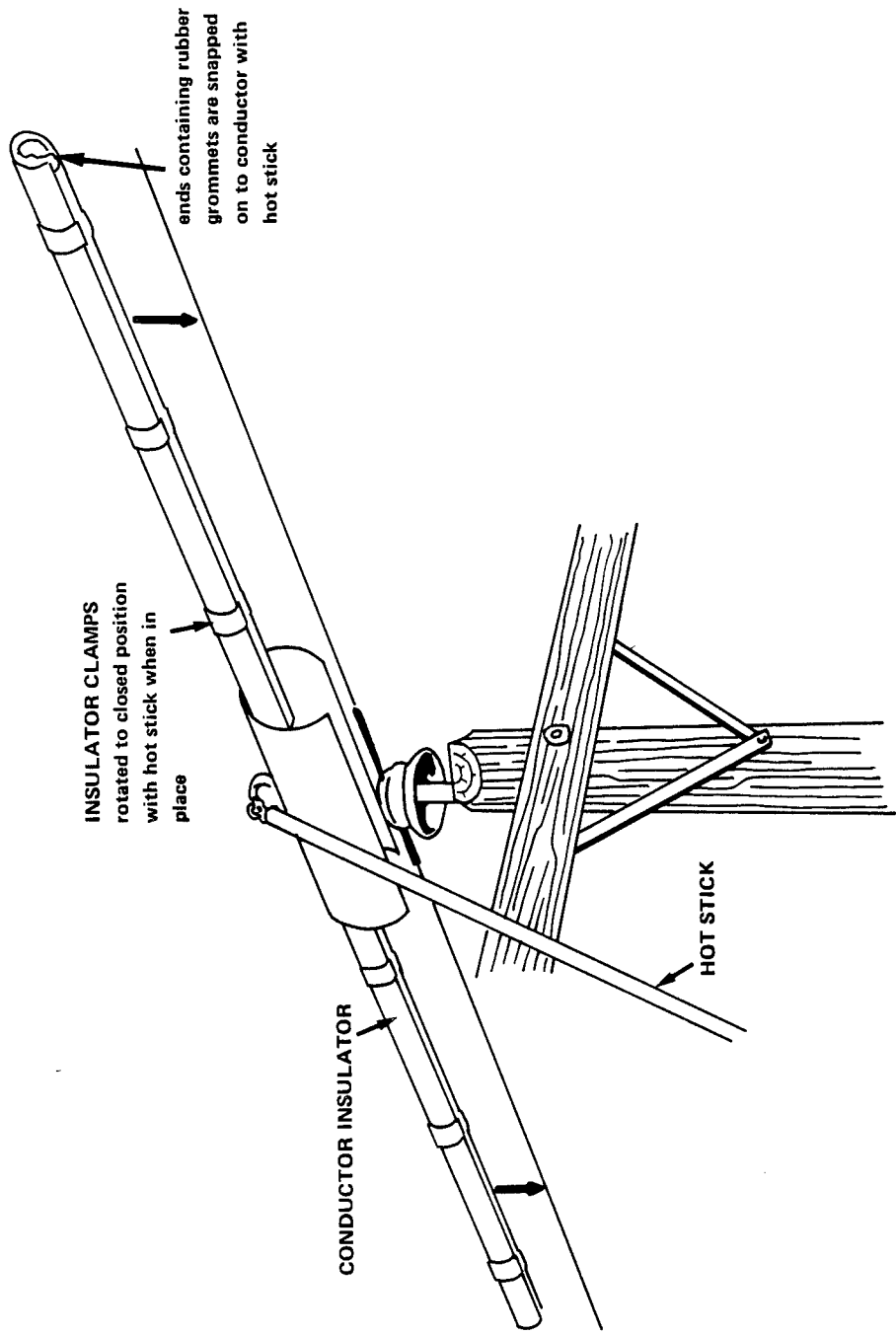

Figure 3.1-5. Protective conductor insulation cover for installation on poles used by raptors as an alternative to pole reconstruction (after Ansell and Smith 1980).

- o When clearing rights-of-way, practices should be used which minimize the amount of cutting and reduce marring of the landscape and silting of streams.
- o Revegetation and closure of access roads should occur as soon as possible after the power line has been installed. Plants should be used that have value as food and cover for wildlife, if this is compatible with the postmining land use, and if approved by the regulatory authority. Brush or small trees which are cut for clearing can be piled to provide cover habitat for small animals and birds (see Section 3.3.3.e, Brush Piles).

SOURCES OF INFORMATION

References Cited:

- Ansell, A. R.; Smith, W. E. Raptor protection activities of the Idaho Power Company. Pages 56-70 in Howard, R. P., and J. F. Gore, eds. Workshop on raptors and energy developments; 1980.
- Steenhof, K. Management of wintering bald eagles, U.S. Fish and Wildlife Service, FWS/OBS-78/79; 1978.

Additional References:

- Raptor Research Foundation. Suggested practices for raptor protection on powerlines. Provo, UT; 1975.
- Rural Electrification Administration. Powerline contacts by eagles and other large birds. REA Bull. No. 61-10; 1972.*
- U.S. Department of Interior; U.S. Department of Agriculture. Environmental criteria for electric transmission systems; 1970.*
- U.S. Department of Interior. Management of transmission line rights-of-way for fish and wildlife. Volume 1. Background information. U.S. Fish and Wildlife Service, FWS/OBS-79/22; 1979.
- U.S. Department of Interior. Management of transmission line rights-of-way for fish and wildlife. Volume 2. Eastern United States. U.S. Fish and Wildlife Service, FWS/OBS-79/22; 1979.

*These guidance manuals may be available at the nearest Office of Surface Mining office or the central office of the State regulatory authority. These offices must be consulted before construction begins, and the operator must check with the appropriate State regulatory authority to find out specific criteria for construction and design.

U.S. Department of Interior. Management of transmission line rights-of-way for fish and wildlife. Volume 3. Western United States. U.S. Fish and Wildlife Service, FWS/OBS-79/22; 1979.

U.S. Department of Interior. Impacts of transmission lines on birds in flight. U.S. Fish and Wildlife Service, FWS/OBS-78/48; 1978.

c. Stream crossings.

PURPOSE

Stream crossings may have several adverse impacts on fish and wildlife. Clearing and shaping of the stream banks cause temporary sedimentation of the stream. Removal of stream-bank vegetation not only destroys wildlife cover but increases the chance that erosion and sedimentation will occur and destroy the aquatic habitat by silting over spawning and feeding areas. In some cases, structures impeding fish movement could significantly affect upstream travel to spawning grounds, resulting in population decline.

Crossing streams for exploration, access, and haul roads should be kept to a minimum. Any stream crossing, whether temporary or permanent, must be approved beforehand by the Federal or State regulatory authority. Where drainage structures are required for stream-channel crossings, they must not affect the normal flow or gradient of the stream or adversely affect fish migration, aquatic habitat, or related environmental values.

DEVELOPMENT

The development of buffer zones to protect streams is often times needed and may be required by the regulatory authority. The width is established through consultation with the regulatory authority. These areas are set aside for the purpose of preventing erosion of streambanks and sedimentation of streams. In addition, these areas provide "edge" for wildlife; protective cover for terrestrial wildlife; water, shading, and cover for aquatic species; and habitat for nesting and feeding of both terrestrial and aquatic wildlife. In essence, these zones protect many facets of fish and wildlife habitat. For more information, see Section 3.2.2.a, Establishment of Buffer Zones.

Crossings may be accomplished in several ways, depending on the type of road and the type of stream. Fords may be used to cross streams on a temporary basis during construction of Class I and Class II roads. In the case of Class III roads (access other than haul roads and are used less than six months), temporary fords may be used to cross ephemeral and intermittent streams. Culverts and/or bridges must be used with Class I and II roads and where Class III roads cross perennial streams.

Fords - Several considerations should be made with respect to temporary stream fords.

- o Place rock or other stabilizing material on the approach and exit to reduce erosion and sedimentation of aquatic habitat.
- o Align the crossing at right angles to the stream to minimize stream-bed disturbance.
- o Choose a crossing point with stable bottom materials to prevent erosion.

- o Revegetate the streambank upon abandonment of the crossing to re-establish the riparian habitat and stabilize the bank to prevent erosion.

Culverts/Bridges - Culverts/bridges must be designed to handle predicted site-specific precipitation events. Since culverts/bridges are subject to regulatory changes, assistance in premining planning should be sought from the regulatory agency or OSM.

The type and size of the culverts/bridges and installation specifications will depend on site-specific considerations. Engineering specifications should be obtained from publications that provide criteria for construction methods approved by the regulatory authority.

Certain factors in the design of culverts/bridges must be considered to provide minimal impediment to fish movement. Major factors are:

- o Culvert outlets must not be above streambed level, preventing upstream movement of fish.
- o Flow through the culvert must not be too fast and shallow, impeding movement of fish.
- o Riprap and materials used to stabilize the culverts/bridges must not impede natural channel flow, restricting movement of fish.

Several methods have been demonstrated to provide fish passage through culverts (Watts 1974; Evans and Johnston 1976). However, only the arch culvert (Figure 3.1-6) has been shown to be effective in maintaining "natural" water flow. A pipe culvert may be set below the streambed level to allow passage of fish. This eliminates the problem of a culvert ending above the streambed level. Streambed gravel in the culvert and the slope of the culvert help control the natural rate of flow so that the culvert does not become a barrier.

MAINTENANCE AND MANAGEMENT

Debris that collects in the culvert or against bridge structures can also impede fish movement. Periodic checks should be made and such materials should be removed. Culverts and bridges must be maintained within appropriate standards as required by the Federal and State regulatory agencies.

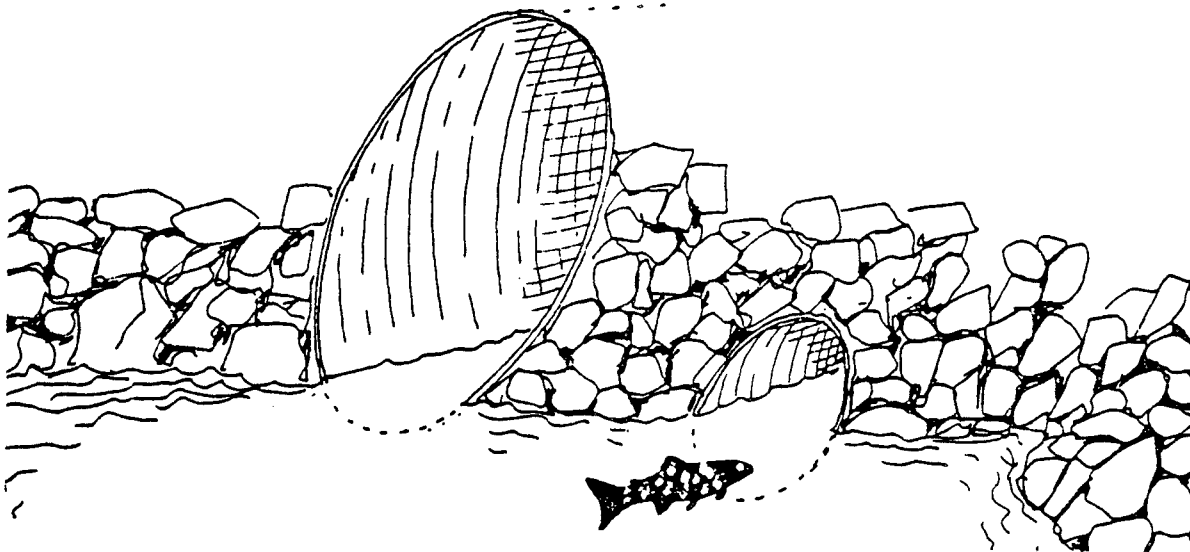

Figure 3.1-6. The arch culvert provides for fish passage (from Nelson et al. 1978).

LABOR/MATERIALS

Culvert or bridge materials, equipment operation, fill haulage, fill placement, and labor cost will vary according to stream width, slope of stream bank, and other site-specific considerations. Most road building contractors and State highway department personnel have ready access to the cost of such materials. Some States maintain a Unit Bid Price List that contains costs of these and related activities. Some sample costs of culverts are given below:

<u>Corrugated Metal Pipe Culvert</u>	<u>Average Price</u>
91 cm (36 in)-14 gauge	\$ 27.23 per 0.3 m (lin ft)
122 cm (48 in)-14 gauge	34.82 per 0.3 m (lin ft)
183 cm (72 in)-16 gauge	66.43 per 0.3 m (lin ft)
<u>Corrugated Metal Area Culvert</u>	
89 x 61 cm (35 x 24 in)-14 gauge	\$ 24.06 per 0.3 m (lin ft)
125 x 84 cm (49 x 33 in)-14 gauge	30.78 per 0.3 m (lin ft)
285 x 191 cm (112 x 75 in)-12 gauge	110.00 per 0.3 m (lin ft)

SOURCES OF INFORMATION

Further guidance and information on stream crossings may be acquired from:

- o State Regulatory Authority
- o Office of Surface Mining
- o U.S. Forest Service
- o State Highway Department
- o U.S. Army Corps of Engineers
- o Soil Conservation Service

For addresses, see Appendix A.

References Cited:

- Evans, W. A.; Johnston, F. B. Fish migration and fish passage - A practical guide to solving fish passage problems. U.S. Forest Service; 1976.
- Nelson, R. W.; Horak, G. C.; Olson, J. E. Western reservoir and stream habitat improvements handbook. Western Energy and Land Use Team, U.S. Fish and Wildlife Service. FWS/OBS-78/56; 1978.
- Watts, F. J. Design of culvert fishways. Water Resources Research Institute, University of Idaho, Moscow, ID; 1974.

d. Fences.

PURPOSE

Fencing may be used to exclude pronghorn or deer from areas such as toxic ponds and reclamation areas to reroute pronghorn or deer around haul roads and similar areas, and to allow pronghorn or deer to pass freely while excluding certain animals, such as cattle. With careful design, fencing can be used to accomplish its purpose on the surface mine area with minimal impact on the big game animals present.

DEVELOPMENT

Antelope (pronghorn)

Several types of fences may be used for various purposes on antelope range. Listed below are some common fencing applications and the specific type of fence which can be used to solve them:

<u>Problem</u>	<u>Fence Type</u>
o During winter, fence out cattle in areas of antelope concentration and migration routes.	Three strands barbed wire, barbless bottom wire (Figure 3.1-7A).
o During winter, fence out sheep in areas of antelope concentration and migration routes.	Four strands barbed wire, barbless bottom wire (Figure 3.1-7B).
o During winter, fence out cattle and sheep in areas of antelope concentration and migration routes.	Four strands barbed wire, barbless bottom wire (Figure 3.1-7C).
o Fence out cattle and horses, but allow other wildlife access (no sheep present).	Four barbed strands (Figure 3.1-7D).
o Fence out all livestock and antelope.	Woven wire (Figure 3.1-8B).
o Fence out sheep, cattle, and horses, as well as deer and other high-jumping wildlife.	Woven wire (Figure 3.1-8A).

Since antelope typically will not jump fences, fence type and location must consider antelope. For example, an angle of 90° is very hazardous during blizzards because antelope tend to crowd into corners. Several small angles in corners (Figure 3.1-9) will prevent this from happening. Fences should also

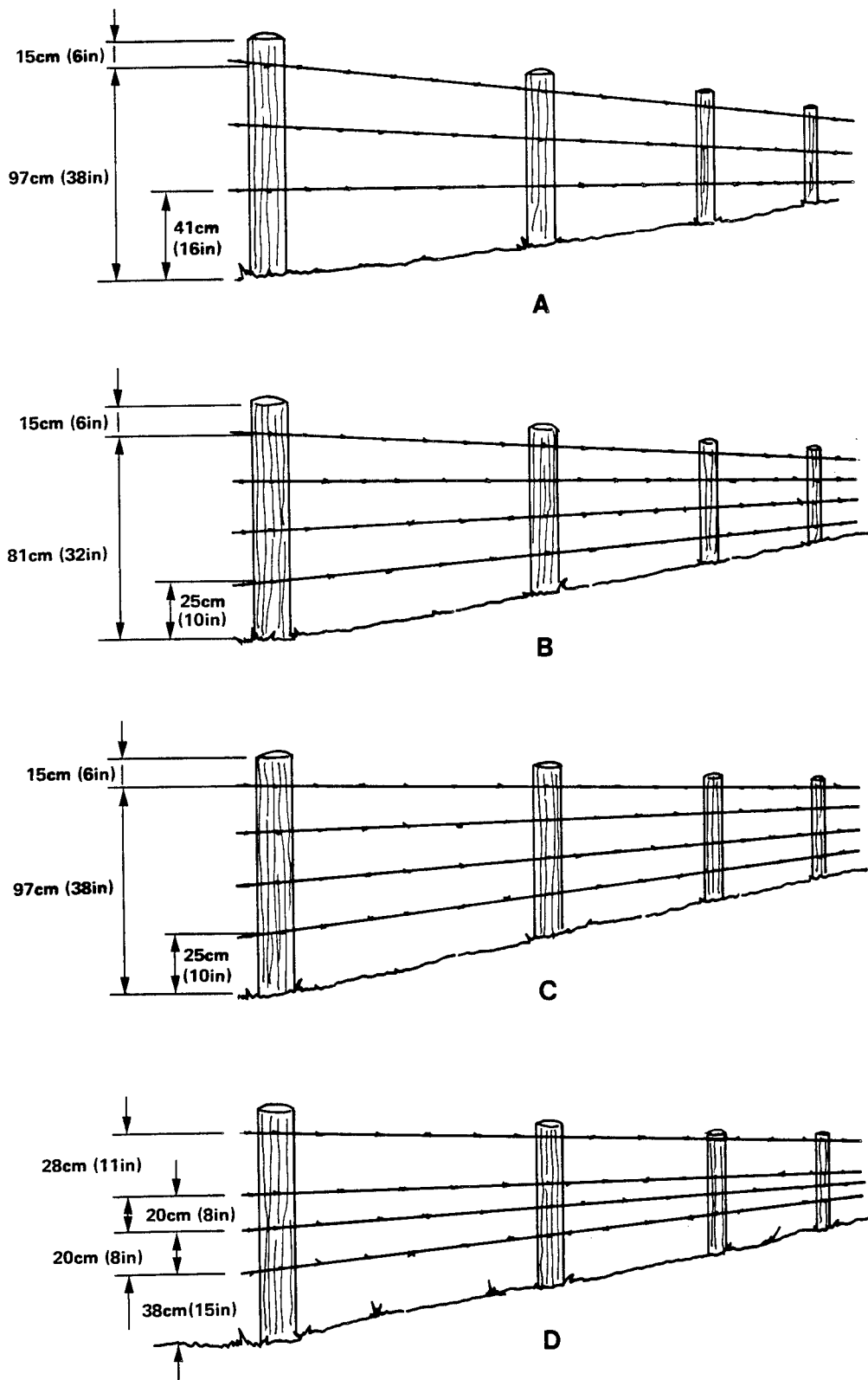

Figure 3.1-7. Fence types including cattle tight (A), sheep tight (B), cattle-sheep tight (C), and cattle-horse tight (D) where deer, elk, and moose are present.

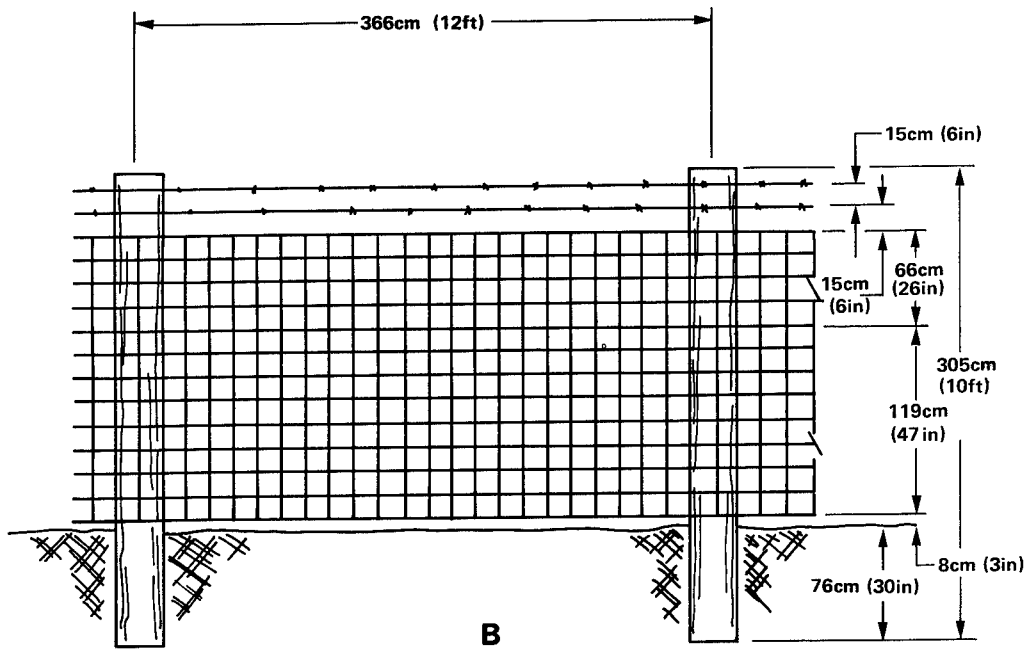
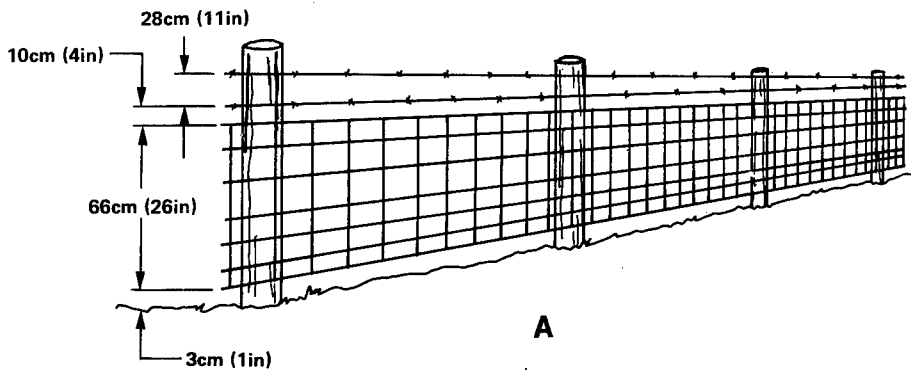
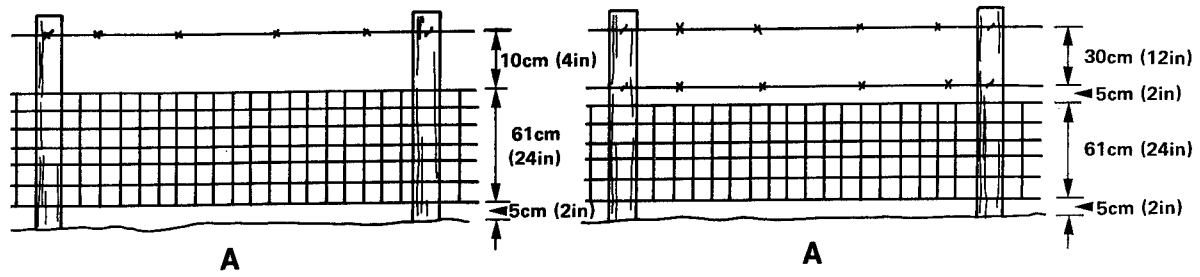
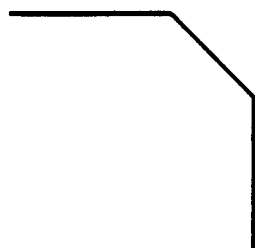
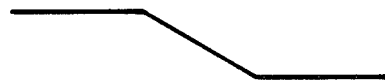

Figure 3.1-8. Woven wire fencing on antelope range including tall sheep tight (A), and cattle-horse tight (B) where deer, elk, and moose are present and sheep are absent.



Fenceline Corner

A



Narrowing Down Right-of-Way

B



C

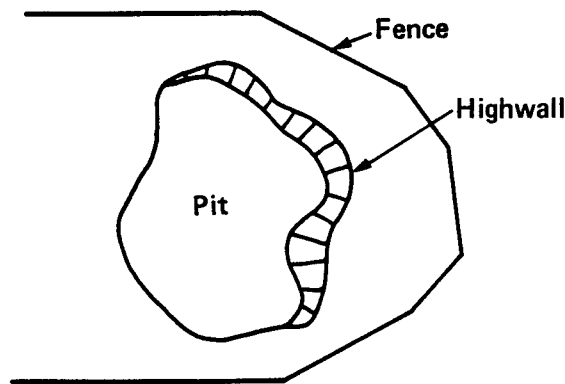

D

Figure 3.1-9. Fencing layouts for preventing corner pile-up during blizzards (A-B) and for directing animals around reclaimed or hazardous areas (C-D).

be angled along migration routes (Figure 3.1-9) rather than at right angles to the path of movement. Such angled fencing will help guide animals around hazardous areas.

Where sheep-tight fencing has to be used (Figure 3.1-8A), underpasses, overpasses, or other passageways should be placed every mile and at natural crossings. Antelope will not normally use an underpass. Passageways, such as cattle guards (Figure 3.1-10), placed at fence corners and other locations will allow antelope movement through fences but should not be used in place of fences that will permit passage of antelope (Mapston and ZoBell 1972).

Standards for constructing fences may vary from State to State and on Federal lands. Check with State authorities and the Bureau of Land Management to ensure that proper standards are met.

Deer

Deer characteristically jump over fences, and this often leads to entanglement and death. While the adult deer is jumping, its hind feet can become entangled between the top two wires of range fences. The best fence adapted to allow deer passage should contain the following specifications (Yoakum et al. 1980).

- o Bottom wires up 40.6 cm (16 in) from ground, allowing for movement of fawns.
- o Only three strands of wire required. On open rangeland, this is enough to control cattle.
- o Top wire is smooth and 91.4 cm (36 in) from ground, thus allowing deer greater ease in jumping over the fence.
- o Stays are placed between posts to make a more rigid fence, since deer frequently become entangled when the top two wires twist around the legs.

To keep deer out of an area, such as an area being reclaimed, a woven mesh wire fence at least 1.8 m (6 ft) in height is required; however, a fence height of 2.4 m (8 ft) is preferred. Since deer will crawl under a fence wherever possible, the mesh wire should be secured and kept close to ground level. An extra strand of barbed wire stretched along the ground will help prevent deer from crawling under.

MAINTENANCE AND MANAGEMENT

Fencing should be checked periodically for broken wire, loose staples, and broken or fallen posts. Replacement or repair is necessary until the need for the fence has passed. On BLM land, fencing must be maintained to current BLM standards.

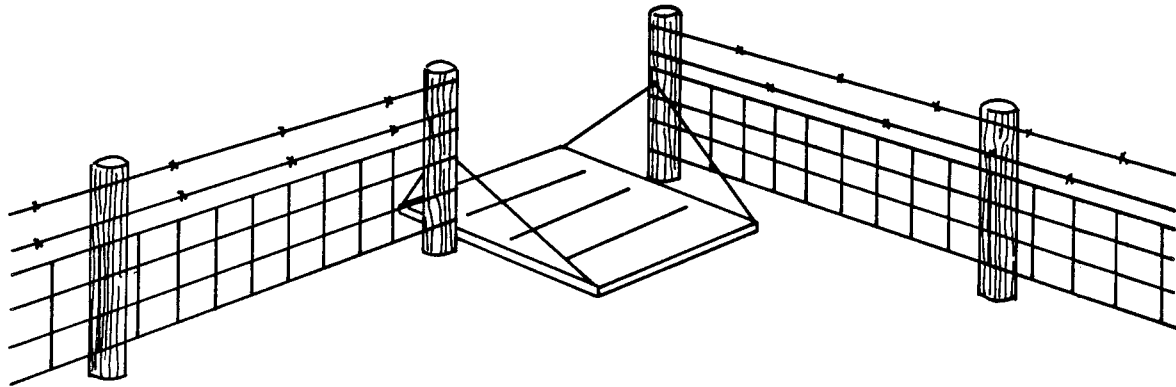

A

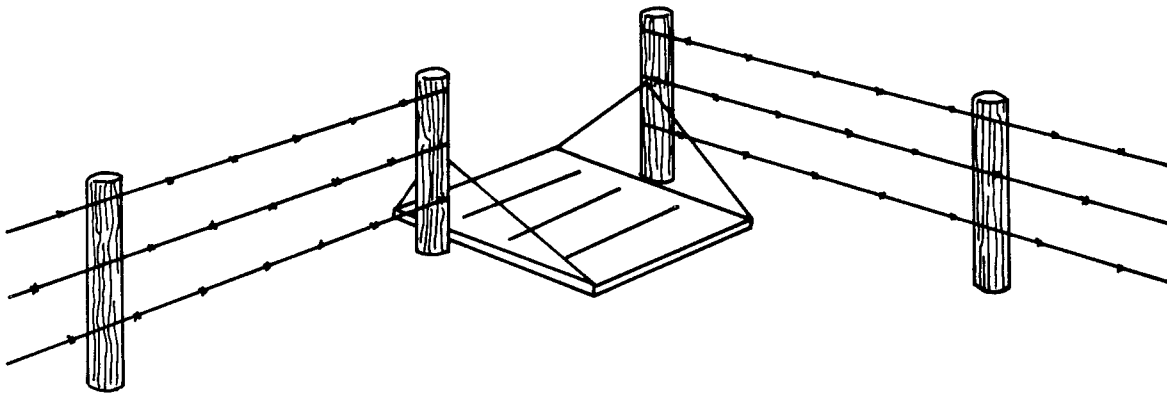

B

Figure 3.1-10. Antelope passes utilizing cattleguards on woven-wire, sheep tight (A) and barbed wire, cattle tight fencing (B).

LABOR/MATERIALS

Cost, man-hours, equipment, and materials needed for fence construction will vary with type of fencing and site-specific characteristics, such as terrain, vegetation types, etc. For example, a square 0.4-ha (1-acre) area on level, cleared land will generally require the following materials and labor in order to enclose the site with livestock-proof fencing, 81 cm (32 in) high (U.S. Forest Service 1969):

<u>Cattle Range</u>	<u>Sheep Range</u>
3 strands of barbed wire spaced at 20, 41, and 61 cm (8, 16, and 24 in) from the ground up, with top rails.	81-cm (32-in) woven wire, with rails. Woven wire is stapled to the top pole.
14 corner and brace posts (15 cm [6 in] diameter and 1.7 m [5.5 ft] long).	Same.
39 lineposts on 3.7 m (12 ft) centers (15 cm [6 in] diameter and 1.4 m [4 ft 8 in] long).	Same.
54 rails ¹ , 10 cm [4 in] diameter and 3.7 m [12 ft] long.	Same.
125 rods barbed wire.	None.
None.	200 m (40 rods) woven wire (81 cm [32 in]).
2.3 kg (5 lbs) of staples (3.8 cm [1.5 in]).	2.7 kg (6 lbs) of 3.8-cm (1.5-in) staples.
5.5 kg (12 lbs) of nails (40 d).	Same.

¹Rails give adequate bracing, so no brace material is needed.

The number of man-hours necessary to construct the fence described above will vary with the equipment used (e.g., mechanical post hole diggers, etc.). However, approximately 60 to 80 man-hours will be needed in most cases.

SOURCES OF INFORMATION

More information on the use and construction of fences may be obtained from:

- o State Regulatory Authority
- o Office of Surface Mining

- o State Game and Fish Agencies
- o U.S. Fish and Wildlife Service
- o U.S. Bureau of Land Management
- o U.S. Soil Conservation Service
- o U.S. Forest Service

For addresses, see Appendix A.

References Cited:

- Mapston, R. D.; ZoBell, R. S. Antelope passes, their value and use. USDI Bur. Land Manage. Tech. Note D-360; 1972. 11 p.
- U.S. Forest Service. Wildlife Habitat Improvement Handbook. Washington, DC.: U.S. Forest Service; Forest Service Handbook No. 2609.11; 1969.
- Yoakum, J.; Dasmann, W. P.; Sanderson, H. R.; Nixon, C. M.; Crawford, H. S. Habitat improvement techniques. Schemnitz, S. D., et al. Wildlife management techniques manual. Washington, DC.: The Wildlife Society; 1980.

Additional References:

- Dorn, R.; Strickland, D. Fencing. Cheyenne, WY: Wyoming Department of Environmental Quality, Land Quality Division; Guideline No. 10; 1979.
- U.S. Bureau of Land Management. Fencing. Denver, CO: Bureau of Land Management; BLM Manual Insert 1737; 1975.

3.1.2 Habitat Improvements on Adjacent Areas to Increase Carrying Capacity

PURPOSE

Because there is such drastic disturbance of wildlife habitat during strip mining, it is possible to compensate for some of these losses by increasing the carrying capacity of adjacent or nearby property. This practice would be useful under any of the following conditions:

- o The State requires mitigation measures for destruction of wildlife habitat.
- o Adjacent land is owned by the mining company.
- o Adjacent landowner wishes the land to be improved for wildlife.
- o Adjacent land is federally or State owned and an agreement could be made following multiple use guidelines.

DEVELOPMENT

In all habitats, there is a limitation on the number of animals of any one species that can be maintained. That limitation is known as the carrying capacity (Dasmann 1964). Carrying capacity can be increased by concentrating on the needs of a single species, or by improving a habitat requirement, such as water, that might be limiting the abundance of several species and the number of individuals of each species.

Food

Food is one requirement that can be enhanced to increase carrying capacity. The amount of food can limit the abundance of a species; however, the nutritional components of the food, although less obvious, may limit the carrying capacity.

For meat-eaters (coyote, bobcat), nutritional requirements are met by consuming other animals. Generally, the carnivores do not suffer nutritional deficiencies, but often the quantity of food is limited. Seed-eating birds and mammals (rodents) obtain most of their dietary requirements from the seeds they eat. Again, food quantity, rather than nutritional quality, is the most likely deficiency.

Seasonally, grazers and browsers (deer, antelope) can suffer from deficiencies in food quality. A shrub may contain 16% protein in its terminal twigs during summer and only 3 to 4% in winter. Grazers thrive on tender young shoots, buds, and leaves, but may encounter nutritional difficulties when forced to eat old, coarse foliage.

Providing a balanced diet for grazers and browsers involves the maintenance of a variety of highly nutritional foods. For example, if the goal is to improve the habitat for pronghorn, the following nutritional conditions and composition (Yoakum 1979) should be incorporated into the reclamation plan:

- o Ground cover averaging 50% living vegetation and 50% nonliving vegetation.
- o The general composition of vegetation should be 40 to 60% grass, 10 to 30% forbs and 5 to 20% browse.
- o A variety of species should be present, including 5 to 10 species of grasses, 20 to 40 species of forbs, and 5 to 10 species of shrubs.
- o Succulent plants are much preferred.
- o Vegetation should average 38 cm (15 in) in height.

It should be remembered that other factors, such as water, should also be considered in providing optimum pronghorn habitat.

Soil fertility can also be a factor in providing adequate nutritional components. A general relationship between soil fertility, food quality, and the abundance, size, health, and vigor of wild animals has long been known (Albrecht 1944). One method of improving habitat would be to fertilize with soil amendments to provide not only more vegetation, but more nutritious forage (See Section 3.3.1.b, Fertilization). Irrigation of adjacent lands would similarly produce a greater quantity of forage, as well as a greater diversity of available succulent vegetation. In many places in the Powder River-Fort Union Coal Region, the availability of water for irrigation is low. (For more information, see Section 3.3.1.i, Irrigation.)

Water

In many areas of the west, water sources may be so far apart that the range between them is poorly utilized, even though the forage and other habitat requirements are entirely adequate. For example, studies in Wyoming disclosed that 95% of 12,465 pronghorn were within a 4.8 to 6.4 km (3 to 4 mi) radius of water (Sundstrom 1968). To increase utilization on such areas, more water must be developed. For a discussion of creating water sources for wildlife, see Section 3.3.2.b, Supplementary Water Resources.

Interspersion

Spatial relationships of habitat components are an important factor in determining habitat utilization. The "edge effect" means that wherever two habitat types come together, the edge between the two types will be more favorable as wildlife habitat than either type considered alone (Odum 1959). It is possible to change a nearby monotypic or low diversity pasture into an area of more value to wildlife by adding "patches" of vegetation of a different species or structure, such as by adding shrubs to a grassland or by planting trees in a natural gully. Besides seeding or planting, it is also possible to reduce competition between desirable browse plants and less desirable species. Four general methods of reducing competition are mechanical and manual treatment, chemical sprays (see Section 3.3.1.j, Pest Control), and prescribed burning.

Vegetative manipulation projects, such as chaining, can change the aesthetic and biological values of an area. Consequently, it should be conducted with caution and with a clear idea of the principles and procedures for pre-treatment, treatment, and post-treatment.

Chaining is a mechanical method which consists of dragging a heavy chain through vegetation to break off or uproot woody plants (see Figure 3.1-11). The general procedure is for two tractors, one attached to each end of the chain, to travel on parallel courses 18.3 to 30.5 m (20 to 33 yd) apart (Yoakum et al. 1980). The spacing is dependent upon density of vegetation, weight and length of chain, size of tractors, bite of tracks, and slope. The degree of kill desired is dependent upon chain size, number of passes, and direction of passes.

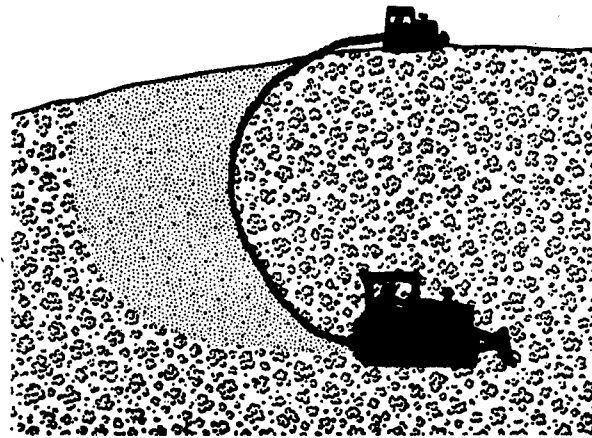

Figure 3.1-11. Chaining to improve wildlife habitat.

Plowing with a heavy offset disc or wheatland plow is used to open up thick strands of nonsprouting plants, such as sagebrush. A brushland plow is best for rough, moderately rocky areas.

Controlled burning is an economical procedure for removing a stand of vegetation but must be done with extreme care to prevent wildfire from starting. Burning may immediately stimulate plant growth, resulting in greater forage yield (Yoakum et al. 1980). On burned areas, soil fertility is usually increased due to the release of nutrients. Most prescribed fires lead to an increase in protein content and palatability of resprouting plants. For more information on the use of fire in land management, see the annual Proceedings of the Tall Timbers Fire Ecology conferences which have been held since 1962.

MAINTENANCE AND MANAGEMENT

Maintenance and management will depend upon the habitat improvement practice used and the length of time involved.

LABOR/MATERIALS

Most of the habitat improvement practices discussed in this section are labor intensive and expensive. The actual cost involved will vary according to technique and how it is applied. Costs for fertilizing (Section 3.3.1.b), irrigation (Section 3.3.1.i), and creating additional water sources (Section 3.3.2.b) are discussed under the appropriate section. Fire is probably the least expensive of the vegetation manipulation techniques because minimal equipment is required. Chaining, plowing, and other mechanical control methods require the use of heavy equipment (e.g., tractors, bulldozers, etc.) and can treat 4 to 16 ha (10 to 40 acres) of rangeland per hour.

SOURCES OF INFORMATION

- o State Regulatory Agency
- o Office of Surface Mining
- o State game and fish agencies
- o U.S. Bureau of Land Management
- o U.S. Forest Service
- o University wildlife departments

For addresses, see Appendix A.

References Cited:

- Albrecht, W. A. Soil fertility and wildlife: cause and effect. Trans. N. Amer. Wildl. Conf. 9:19-28; 1944.
- Dasmann, R. F. Wildlife biology. New York, New York: John Wiley & Sons, Inc; 1964.
- Odum, E. P. Fundamentals of ecology. Philadelphia, Pa.: W. B. Saunders Company; 1959.
- Sundstrom, C. Water consumption by pronghorn antelope and distribution related to water in Wyoming's Red Desert. Antelope States Workshop Proc. 3:39-46; 1968.
- Yoakum, J. D. Pronghorn. Schmidt, J. L.; Gilbert, D. L. eds. Big game of North America. Harrisburg, Pa.: Stackpole Books; 1979.
- Yoakum, J.; Dasman, W. P.; Sanderson, H. R.; Nixon, C. M.; Crawford, H. S. Habitat improvement techniques. Schemnitz, S. D., ed. Wildlife Management techniques manual. Washington, D.C.: The Wildlife Society; 1980.

Additional References:

- Green, L. P. Fuelbreaks and other fuel modification for wildland fire control. USDA For. Serv. Agric. Handbook 499; 1977.

- Pechanec, J. F.; Plummer, A. P.; Robertson, J. H.; and A. C. Hull, Jr. Sagebrush control on rangelands. USDA Agric. Handbook 277; 1965.
- Plummer, A. P.; Hull, A. C.; Stewart, G.; Robertson, J. H. Seeding rangelands in Utah, Nevada, southern Idaho, and western Wyoming. USDA For. Serv. Agric. Handbook. 71; 1955.
- Tall Timbers Fire Ecology Conference Proceedings. (See local library for source of Proceedings.)
- U.S. Forest Service. Range seeding equipment handbook. Washington, D.C.; 1965.
- Vallentine, J. F. Range development and improvements. Brigham Young Univ. Press, Logan, Utah; 1971.

3.2 PRACTICES USED DURING MINING TO ENHANCE AND/OR PROTECT FISH AND WILDLIFE RESOURCES

This section provides the operator with a series of BCP's which provide guidance on creating zones that protect wildlife or their habitat or which suggest techniques by which continued disturbance is restricted. It is only through the conservation and rehabilitation of spoils and topsoils that a useful wildlife habitat can be created after mining.

The requirements and procedures of handling topsoil, spoil, and overburden vary between mines, or even between different portions of one mine, due to differences in topsoil and overburden thickness, amount of material to be stockpiled, chemical and physical characteristics of stockpiled material, length of time materials are to be stored, etc. Procedures also differ with individual State regulations. Site-specific requirements should be obtained from the State regulatory authority and OSM.

3.2.1 Overburden and Soil Handling

a. General procedures. Incorporating the proper procedures for handling overburden and soil materials into the mine plan is necessary to ensure successful reclamation. The decisions on how these materials will be handled will depend in large part on their physical and chemical characteristics, which are determined during the premining analysis of the overburden and soils. The amount of sampling required for the analysis depends on applicable Federal and State regulations, the amount of on-site disturbance, and problems foreseen on the site based on other activities in the area.

The object of the sampling and analysis is to obtain a general knowledge of the soils and overburden and to detect inhibitory zones in the overburden. Site-specific procedures can then be instituted to provide the best situation for counteracting problems in toxicity, salinity-sodicity or acidity, infertility, weatherability, and erodibility. Successful reclamation is dependent on the ability to stabilize a site and to reestablish a good vegetative cover.

Depending on the site-specific situation, mining procedures almost always include:

- o segregation and treatment of toxic materials.
- o segregation and amendment of topsoil, subsoil, and/or soil substitute to be used as a medium for revegetation.

For specific requirements within any one State, the State regulatory authority must be contacted and its regulations followed.

Each mine site will require different procedures, depending on the physical and chemical characteristics of the overburden. It is highly advisable to solicit the help of experts to identify potential problem areas so that mitigative actions can be incorporated into the overall mine plan. The regulatory authority can advise on problems that have occurred in the area,

and local soil conservationists can advise on problems related to soil and overburden handling to achieve the best reclamation. General publications, such as the following, provide overviews that can aid in planning:

- o USDA Forest Service. User Guide to Soils - Mining and Reclamation in the West. Intermountain Forest and Range Experiment Station, U.S. Forest Service, Ogden, UT. Gen. Tech. Rpt. INT-68, SEAM; 1979.
- o USDA Forest Service. Procedures Recommended for Overburden and Hydrologic Studies on Surface - Thunder Basin Project. Intermountain Forest and Range Experiment Station, USDA Forest Service, Ogden, UT. Gen. Tech. Rpt. INT-71, 1980.

It is the responsibility of the operator to gather sufficient data to describe soil and overburden characteristics, propose methods to alleviate any problems, and obtain approval from the regulatory agency on the proposed methods. Information provided in the following sections is designed to provide further guidance in handling overburden and soil materials.

b. Selective placement and stabilization of spoils and topsoils.

PURPOSE

In the mining process, it is important to identify problem-producing strata in the overburden so that they can be handled in such a manner that they will not create spoils that are toxic to plants. Basically, this means separating acid-forming and toxic-forming strata from the neutral or non-acid forming and non-toxic forming strata and burying the acid- and toxic-forming strata at the proper depth within the neutral material to prevent leaching, contact with ground water, and contamination of topsoil or soil substitute. Topsoil removal, stockpiling, and replacement on top of graded spoil is required by regulation in Montana, North Dakota, and Wyoming. To determine placement of spoils and topsoil during the mining process, the following should be considered:

- o whether storage needs will be permanent or temporary;
- o the quantity and characteristics of the material to be stored;
- o potential toxicity and stability problems during storage;
- o slope and aspect of the storage pile;
- o access of the mine operator to the storage site;
- o effect of wind and water on the storage site and the need for erosion control practices;
- o effects of material storage on adjacent land uses;
- o treatment, if necessary, to neutralize the material before placement;
- o location of the stored acid-forming or toxic-forming material within the fill to segregate materials from aquifers; and
- o location of fill to segregate it or runoff from it from water courses.

DEVELOPMENT

In the Northern Great Plains, the depth of topsoil ranges from 12.7 to 91.4 cm (5 to 36 in) and averages 30.5 cm (12 in) (Barth 1977). Topsoil is the dark-colored, unconsolidated surface material which supports plant growth. The precise definition of topsoil varies from State to State.

In 1977, 24% of the surface mines in the Northern Great Plains were applying a layer of subsoil between the topsoil and spoils (Barth 1977). Depth of subsoil averages 83.8 cm (33 in) and ranges from 61 to 101.6 cm (24 to 40 in). Subsoil can be described as the light-colored, unconsolidated

subsurface material found adjacent to the topsoil and within 1.5 m (5 ft) of the surface. The depth of topsoil and subsoil applied to spoils is determined by State regulations and by the supply of soil.

Direct topsoil respreading from the mine's working face to the area to be reclaimed is favored by most companies because it is the least expensive method of handling and it is best for maintaining soil characteristics. Although placement of topsoil from the area of removal directly to graded spoil reduces the cost of topsoil handling by at least 50%, all mines in the Northern Great Plains find it necessary to stockpile some topsoil and 82% of the mines stockpile all of their topsoil (Barth 1977).

Topsoil stockpiles must be graded and seeded if the material is to be stored for any length of time. This practice prevents erosion of the stockpile. Because stockpiles are constructed with scrapers, topsoil leaching is virtually impossible. Compaction is generally so great that little infiltration occurs. The major problem associated with leaching is the loss of nutrients and subsequent decrease in fertility of the topsoil (Moore and Mills 1977). Deterioration of stockpiled topsoil characteristics is not critical because of the inoculation potential from wind (J. Brown, North American Coal Corp., pers. comm.).

Leaching of stored subsoil or overburden may represent greater potential water quality problems than leaching of the stored topsoil layers. Alkaline spoils are found in arid and semiarid regions where precipitation is insufficient to leach out salts (U.S. Forest Service 1979). Part of the rationale for separating and replacing subsoil materials as soon as possible is that, when replaced, they will provide a chemically and physically compatible base upon which to place the topsoil material (Moore and Mills 1977).

Whether the overburden is stored in piles or in the pit, it will be subject to erosion and leaching processes. The potential for these effects will be largely a function of the degree to which water infiltrates into or runs off the spoiled material and the runoff water control techniques employed. As stated above, piles constructed with scrapers generally have minimal infiltration and leaching.

In the Northern Great Plains, as in other regions, there is some variability in overburden characteristics. For example, the overburden of the North Dakota lignite region, located under Fort Union overburden, weathers to a hard packed, dense, impermeable clay that increases erosion and will not support vegetation unless special reclamation procedures are followed and amendments are added. On the other hand, the overburden in southeastern Montana weathers to a clay and shale weathers to sand. Consequently, the permeability of the mixture is increased and, despite the occasional high sodium content, the overburden can be successfully revegetated without topsoil and without large amounts of soil amendments (Moore and Mills 1977). The use of overburden as a growth medium in this region is sometimes necessary because of the natural paucity of topsoil. Montana, Wyoming, and North Dakota all require detailed soils and overburden testing before mining begins, and many decisions involving overburden treatment must depend on the results of these tests.

If stabilization of spoil piles is necessary, contouring to reduce steep slopes and creating small depressions or furrows to increase water filtration will greatly improve the chance for plant establishment (Institute for Land Rehabilitation 1978).

At the Amax Belle Ayr South Mine near Gillette, WY, Yamamoto (1975) found the sandy soil-sandstone overburden material to be capable of supporting plant growth. Cable (1977) experimented with western wheatgrass plug transplants on raw coal mine spoils in New Mexico and found that this technique was very successful for small problem areas where seeding would otherwise have little chance of success.

In Kemmerer, WY, a study on the use of jute netting as a means for spoil bank stabilization (Lang 1971) showed that, when the jute netting was supplemented with barley straw mulch, it was very effective in reducing erosion. Seedling survival was much greater under the jute netting plus straw mulch than when jute netting was used alone.

The placement and stockpiling of spoils and topsoil may destroy additional wildlife habitat, and leaching of spoils may affect the water quality. Changes in the chemical and physical nature of the soil over time will affect the kinds of plants that can grow once the mined land is reclaimed and thus will influence the type of habitat that is created.

LABOR AND MATERIALS

Scrapers are used to transport topsoil and overburden material to offsite storage locations and back to the mine during reclamation. The amount of labor and equipment time will vary with the size of the operation. According to Barth (1977), most mines estimate that it costs approximately \$1,000 per 0.4 ha (acre) to remove, store, and replace 0.3 m (1 ft) of topsoil. Jim Brown (North American Coal Corp., pers. comm.) estimates that costs run between \$0.50 to \$1.50 to transport 0.76 m³ (1 yd³) from the mine to a stockpile using a scraper.

For information on mulches and seeding, see the appropriate BCP's.

SOURCES OF INFORMATION

- o State Regulatory Authority
- o Office of Surface Mining
- o U.S. Soil Conservation Service

For addresses, see Appendix A.

References Cited:

- Barth, R. C. Reclamation practices in the Northern Great Plains coal province. Mining Cong. J. 63(5):60-64; 1977.

- Cable, D. R. Western wheatgrass transplants grow well on raw mine spoil. USDA Forest Service Res. Note 345. Rocky Mtn. Forest and Range Exp-Sta., Albuquerque, NM; 1977.
- Institute for Land Rehabilitation. Rehabilitation of western wildlife habitat: a review. USDI Fish and Wildlife Service. FWS/OBS 78/86; 1978.
- Lang, R. Reclamation of strip mine spoil banks in Wyoming. Wyoming Agr. Exp. Sta. Res. J. 51; Laramie, WY: U. of Wyoming; 1971. 32 p.
- Moore, R.; Mills, T. An environmental guide to western surface mining. Part two: impacts, mitigation and monitoring. USDI Fish and Wildlife Service. FWS/OBS-78/04; 1977.
- U.S. Forest Service. User guide to vegetation. Gen. Tech Report INT-64; Intermt. For. and Range Exp. Sta., Ogden, UT 84401; 1979. 85 p.
- Yamamoto, T. Coal mine spoil as a growing medium: Amax Belle Ayr South Mine, Gillette, WY. Third Symp. on surf. min. and reclam. Vol. 1. NCA/BCR Coal Conf. and Expo II; Washington, DC: Natl Coal Assoc; 1975.

Additional References:

- Gilley, J. E. Runoff and erosion characteristics of a revegetated surface mined site in western North Dakota. North Dakota Farm Res. 37(6):17-20; 1980.

- c. Use of mycorrhizae to enhance the establishment of woody plants for wildlife food and cover.

PURPOSE

Most flowering plants are associated with a root-inhabiting fungi (mycorrhizae; fungus-roots). The food exchange between the roots of the host plants and the mycorrhizal fungi is a relationship beneficial both to the plant and to the fungi (Marx 1972). According to Parkinson (1978), mycorrhizae represent one of the most important and complex coupling mechanisms between ecosystem components. The response of roots to stresses, such as drought, disease, lack of nutrients, and their patterns of growth and death, may be controlled by the mycorrhizal association. The success of revegetation of mine spoils will be greatly enhanced by the inoculation of the proper species of mycorrhizae into the roots of newly planted seedlings.

Use of mycorrhizae to enhance plant growth on mine spoils is largely an experimental practice and has not been widely applied in the field at present.

DEVELOPMENT

There are two distinct kinds of mycorrhizae, ectocellular, which do not penetrate the cells of the root tissue, and endocellular, which do penetrate the cells.

Ectomycorrhizal fungi growth is stimulated by root secretions, and dispersion to other plants is primarily through root contact. Reproduction may also occur through airborne spores (Marx 1972).

Mine spoils present harsh conditions for both plant and microbial growth because of low organic content, unfavorable pH, and either coarse structure (low water retention and consequent dry conditions) or compacted structure (poor drainage). For areas strip-mined and being reclaimed, most of these problems will be solved or at least lessened during the replacement of topsoil and preparation for revegetating. Tree or shrub seedlings can be inoculated with ectomycorrhizae species to help increase the chance of survival. It is important to use the ectomycorrhizae which has formed an association with the shrubs and trees to be planted.

Generally, inoculation takes place in the nursery where the seedlings were grown (Ruehle and Marx 1979; Marx 1980). Other inoculation methods include introducing duff, humus, infected soil, or excised roots containing mycorrhizae into the growth medium. Although these methods normally ensure ectomycorrhizal development, they may also create undesirable results. The inoculum may lack the most desirable mycorrhizae for the particular woody species and planting site. It usually contains extraneous material that is expensive to transport and harmful microorganisms and noxious weeds. In addition, sufficient quantities of sporophores or colonized roots may not be available when needed.

Endomycorrhizal associations have received greatly increased study over recent years (Parkinson 1978). One problem is that endomycorrhizae have not been cultured with much success.

Aldon (1978) has found Glomus fasciculatus, an endomycorrhizal fungi, associated with rubber rabbitbrush. G. fasciculatus has also been found in association with other western species, including winterfat, mountainmahogany, skunkbush, gambel oak, littleleaf mockorange, and common Apacheplume.

Unfortunately, there is still very little information on the species of endomycorrhizal fungus found with many of the major revegetation plants in the Powder River-Fort Union Coal Region. In addition, no commercial inoculum is available. However, according to Aldon (1981, pers. comm., Earl F. Aldon, U.S. Dept. Agr., Forest Service, Rocky Mountain Forest and Range Expt. Sta., 2205 Columbia, S.E., Albuquerque, NM.), the best method for inoculation of endomycorrhizae is to collect soil from beneath native stands of mature plants of the particular species to be planted. This soil should be mixed with the soil in which the plants are placed. Although this is a tedious method, it is superior to waiting for the spores to blow in from somewhere else. Although aerial dispersion of spores does occur, the time period may be critical in ensuring better survival of transplants. If careful removal of the top few inches of topsoil would occur in the mining process, so that this soil would be placed on top of a reclaimed area, enough mycorrhizal spores might be present and would make inoculation unnecessary.

In addition, Ponder (1979) assayed recently graded stripmined coal spoil and found that plants grown in this soil formed abundant endomycorrhizae in the greenhouse. He concluded that grading could be an important means of dispersing endomycorrhizal inoculum in spoil.

MANAGEMENT AND MAINTENANCE

Once the mycorrhizae has been established, it will spread naturally. Maintenance is not required.

LABOR/MATERIALS

Materials for inoculation of mycorrhizae do not cost anything if soil is taken from around plants that are already infested. The labor costs would be high because of the time involved to find the desired plants, collect the soil, and mix it with the growth medium for the new plants.

According to Dr. Donald Kenney of Abbott Laboratories (pers. comm), Pisolithus tinctorius ectomycorrhizal inoculum is available commercially in small quantities only in the southern U.S. on a test basis. The inoculum sells for \$16 per liter (1.1 quart). This volume, when applied with the injection planter developed by the USDA Forest Service, will inoculate approximately 750 seedlings.

SOURCES OF INFORMATION

Institute for Mycorrhizal Research and Development
USDA Forest Service
Southeastern Forest Experiment Station
Forestry Sciences Laboratory
Athens, GA 30602
(404) 546-2435

Rocky Mountain Forest and Range Experiment Station
USDA Forest Service
Albuquerque, New Mexico
(505) 766-2384

References Cited:

- Aldon, E. F. Endomycorrhizae enhance shrub growth and survival on mine spoils. Wright, R. A., ed. The reclamation of disturbed arid lands. Albuquerque: Univ. of New Mexico Press; 1978.
- Marx, D. H. Mycorrhizae, a type of root infection beneficial to plant growth. *Agrichemical Age* 15(1):13-14, 16; 1972.
- Marx, D. H. Role of mycorrhizae in forestation of surface mines. Proc. trees for reclamation, Lexington, KY. 1980 October 27-28. Interstate Mining Compact Commission and USDA Forest Service: 109-116; 1980.
- Parkinson, D. Microbes, mycorrhizae and mine spoil. Wali, M. K., ed. Ecology and coal resource development. Elmsford, NY: Pergamon Press; 1978.
- Ponder, F., Jr. Presence of endomycorrhizal fungi in recently graded coal mine spoil. *J. Soil and Water Conserv.* 34:186-187; 1979.
- Ruehle, J. L.; Marx, D. H. Fiber, food, fuel and fungal symbionts. *Science* 206:419-422; 1979.

Additional References:

- Aldon, E. F. Endomycorrhizae enhance survival and growth of fourwing saltbush on coal mine spoils. Fort Collins, Colorado: USDA For. Serv. Res. Note RM-294, Rocky Mtn. For. and Range Exp. Stn.; 1975.
- Lindsey, D. L., Cress, W. A., and Aldon, E. F. Endomycorrhizal (vesicular-arbuscular) associations of some arid zone shrubs. *Southwest Natur.* 20(4):437-444; 1976.
- Miller, M. R. Some occurrences of vesicular-arbuscular mycorrhizae in natural and disturbed ecosystems of the Red Desert. *Can. J. Bot.* 57:619-623; 1979.

- Moorman, T., and Reeves, F. B. The role of endomycorrhizae in revegetation practices in the semi-arid West. II. A bioassay to determine the effect of land disturbance on endomycorrhizal populations. Amer. J. Bot. 66:14-18; 1979.
- Williams, S. E.; and Aldon, E. F. Endomycorrhizal (vesicular-arbuscular) associations of some arid zone shrubs. Southwest Natur. 20(4):437-444; 1976.
- Williams, S. E.; Wollum II, A. G.; and Aldon, E. F. Growth of Atriplex canescens (Pursh) Nutt. improved by formation of vesicular-arbuscular mycorrhizae. Soil Sci. Soc. Am. Proc. 38:962-965; 1974.

3.2.2 Wildlife Habitat Improvement and Development

a. Establishment of buffer zones.

PURPOSE

Buffer zones may be used for a wide variety of purposes, such as protecting the nesting sites of threatened and endangered species, protecting critical habitat, providing a visual screen (e.g., to hide a roadway), and protecting streams or other bodies of water from sedimentation and other disturbances.

DEVELOPMENT

Several important factors should be considered in utilizing buffer zones for the purposes outlined above. However, it must be emphasized that different wildlife species have different buffering needs, and zones must be established on a site-specific basis. The specific species involved and the surrounding topography will often determine the time of year a buffer zone is needed and the size and configuration of the zone. Existing vegetation and type of mining practice will dictate the need for additional protective measures.

The protection of nesting sites of threatened, endangered, and otherwise protected species and critical habitats may require the establishment of a buffer zone. The size of the area, maintenance requirements, and management considerations should be determined in consultation with the U.S. Fish and Wildlife Service and State wildlife agency. In the case of extremely unique or rare habitat and/or species, a professional familiar with the local situation may be needed.

In some cases, the actual need and configuration of the buffer zone may be hard to determine. In the case of golden eagles, Tyus and Lockhart (1979) found that the level and proximity of disturbances to eagle nests and other habitats (e.g., hunting perches and feeding areas) are important considerations in mitigating surface mining disturbances (see Section 3.3.3.g, Building Alternative Nest Sites for Golden Eagles). In open country, a zone of 0.8 km (0.5 mi) or more may be required around an eagle nest; whereas, 0.4 km (0.25 mi) may be sufficient if the nest is obstructed from the disturbance by a visual barrier. Because of the complexity of site-specific factors needed to determine the size of the buffer zone, Tyus and Lockhart (1979) suggest that situations be assessed on a case-by-case basis. Protection may be needed not only for nesting but also for perching and foraging habitat. (Refer to the State game and fish department, U.S. Fish and Wildlife Service, and/or the State regulatory authority for species- and site-specific guidance.)

Buffer zones may be used to screen out haul and access roads. In general, roads should be designed to go around important wildlife use areas and be hidden from view by animals using the areas. The width of the buffer zone will vary with the species of concern and site conditions.

Complete or partial fencing of stockponds or permanent impoundments with an appropriate design to allow big game access (see Section 3.1.1.d, Fences)

will improve shoreline cover and water quality. This practice should be compatible with postmining land use.

The method of development of riparian buffer zones to protect streams must be determined through consultation with the regulatory authority. These areas are set aside for the purpose of preventing erosion of streambanks and sedimentation of streams (Figure 3.2-12). In addition, these areas provide "edge" for wildlife, protective cover and a source of water for terrestrial wildlife, shading and cover for aquatic species, and habitat for nesting and feeding. In essence, these zones provide many facets of fish and wildlife habitat.

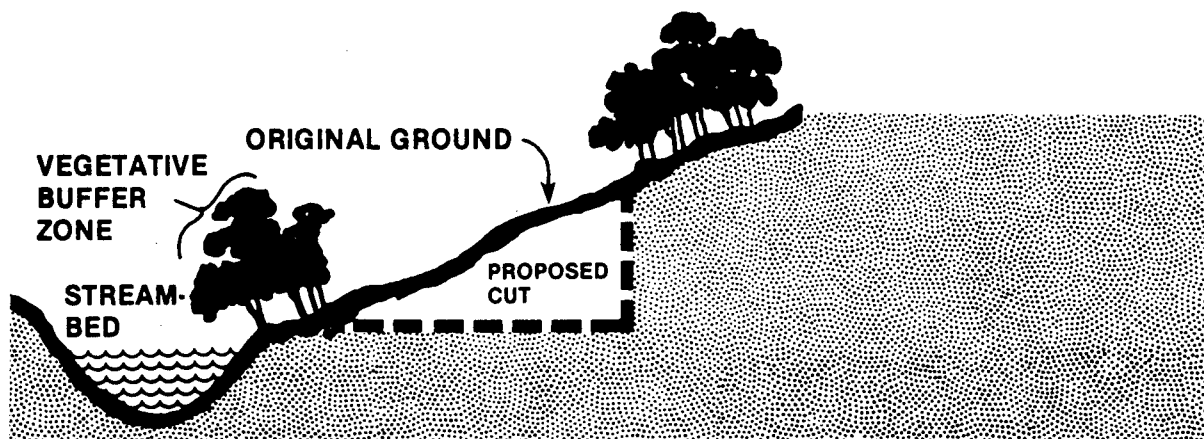

Figure 3.2-12. Vegetative buffer zones to protect stream water quality (after U.S. Environmental Protection Agency 1976).

MAINTENANCE AND MANAGEMENT

The State regulatory authority will provide guidance on specific steps to be taken for delineating, marking, and maintaining stream buffer zones. Maintenance will depend on the specific needs of a site, but, for the most part, once set aside, these areas require little management. However, they could provide an opportunity for adding food plots, planting cover, or producing clearings in such a way as to enhance the buffer zone for wildlife use (see Section 3.3.3.b, Planting Patterns to Increase Wildlife Diversity).

LABOR/MATERIALS

Labor costs will depend largely on many of the factors already discussed. Ordinarily, low or minimal costs are involved since buffer zones are largely precautionary, non-use zones around a sensitive area. Where enhancement for wildlife is incorporated into the management of a buffer zone, the degree of effort and materials will vary with each area.

SOURCES OF INFORMATION

- o State Regulatory Agency
- o Office of Surface Mining
- o State Game and Fish Department
- o U.S. Fish and Wildlife Service
- o Land Management Agencies

References Cited:

- Tyus, H. M.; Lockhart, J. M. Mitigation and research needs for wildlife on western surface mined lands. In: Swanson, G. A., technical coordinator. The mitigation symposium: a National workshop on mitigating losses of fish and wildlife habitats. General Tech. Rept. RM-65. Rocky Mtn. Forest and Range Expt. Station, U.S. Dept. Agr., For. Serv.; 1979. p. 252-255.
- U.S. Environmental Protection Agency. Erosion and sediment control - Surface mining in the Eastern U.S. EPA Tech. Seminar Publ., EPA-625/ 3-76-006; 1976.

Additional References:

- Stubbs, C. W.; Markham, B. J. Wildlife mitigative measures for oil and gas activity in Alberta. In: Swanson, G. A., technical coordinator. The mitigation symposium: A National workshop on mitigating losses of fish and wildlife habitats. General Tech. Rept. RM-65. Rocky Mtn. For. and Range Expt. Sta., U.S. Dept. Agr., For. Serv.; 1979. P. 264-269.

b. Rights-of-way management for wildlife.

PURPOSE

Rights-of-way (ROW) for roads and powerlines often involve large areas of land which require continual maintenance. The primary purpose of powerline maintenance is to protect the lines from damage and to provide access. Along roadways, maintenance is directed toward improving visibility and removing roadside obstacles.

Along heavily used roads, maintenance activities of ROW should not encourage use by large animals. High mortality of deer and other grazing animals occurs frequently along roads, as the animals are hit by vehicles. Vegetation unpalatable to wildlife should be planted to discourage grazing by big game, such as deer, elk, and antelope, and further minimize potential vehicle/wildlife encounters. The benefits from providing more food or cover for these animals along well-used roads would be offset by increasing the chance of injury or death. Animal/vehicle collisions can also be minimized by reducing speed limits.

ROW management along powerlines, however, should be promoted. Powerline corridors are often in isolated areas, providing locations where animals can feed and rest undisturbed. In such areas, the wildlife manager can greatly improve wildlife habitat by appropriate initial cutting and/or replanting and periodic maintenance pruning or thinning.

DEVELOPMENT

A substantial amount of literature is being developed on powerline ROW management for wildlife (Electric Power Research Institute, in press; Tillman 1976; U.S. Department of Interior 1979). The art of powerline ROW management for wildlife is also well-developed for many parts of the country. However, because of the diverse requirements of wildlife species, the variable terrain in a region, and surrounding land uses, all techniques suitable for a region should be considered during ROW planning and management. The publication entitled Management of Transmission Line Rights-of-Way for Fish and Wildlife (U.S. Department of Interior 1979) is an excellent manual and should be consulted. It lists practices which have been successful, as well as plant species suitable for ROW planting in many geographic areas. Several important considerations found in this manual and other publications concerning wildlife habitat management along ROW's are listed below.

Vegetation Management by Mechanical Means

Clear- and selective-cutting techniques have been widely used to manage wildlife habitat, but the specific effects of any method depend on the composition of the vegetation, climate, topography, soil conditions, time of cut, and the interval since last cutting.

For areas where trees are numerous, "hinge cutting" or the "cut-and-bend" method of cutting selected trees eventually produces a low, dense, living brush pile. This provides ideal winter cover for small game. The technique

involves cutting trees just deep enough so that the tops can be pushed over. The lower branches (no longer shaded) grow vigorously, while the connected tops grow upward again.

Bulldozing is a popular way to initially clear a ROW. Typically, seeding and replanting is necessary after the bulldozing to prevent erosion and to improve wildlife habitat (see Section 3.3.1.c, Seeding).

Brush Piling

In general, piling brush, rather than leaving cut brush on the ground or removing it, provides cover for numerous small animals. Piling brush in the downslope of natural depressions and gullies also prevents erosion (see Section 3.3.3.e, Brush Piles).

Long, narrow brush piles, less than 2 m (6 ft) high, are preferable to higher rounded piles. They are most effective when placed near the "edge" of other types of habitat.

Planting and Seeding

Wildlife management through planting and seeding has been practiced for many years in the mid-Atlantic and Southeastern States. It is a relatively newer science in the West and Southwest.

Sagebrush, saltbush, bitterbush, and snowberry are some of the shrub species planted for reclaiming wildlife habitat in the West.

Wetlands

Avoiding wetland areas where possible will protect these valuable and fragile resources for wildlife use. In addition, Executive Orders (Nos. 11990 and 11988) require the protection of wetlands and floodplains that may be impacted by a significant Federal action, such as a strip mine.

Where the ROW impacts wetland areas, management should concentrate on minimizing the impacts, rather than managing the wetlands.

During construction, avoid drainage ditches, spoil banks, or access roads that might restrict or prevent normal water movement.

SOURCES OF INFORMATION

References Cited:

Electric Power Research Institute. Proceedings of the second National symposium on environmental concerns in right-of-way management. Palo Alto, CA; in press.

- Tillman, R., editor. Proceedings of the first National symposium on environmental concerns in right-of-way management. Miss. State Univ: State College, MS; 1976.
- U.S. Department of Interior. Management of transmission line rights-of-way of fish and wildlife. Volume 1. Background information. U.S. Fish and Wildlife Service. FWS/OBS-79/22; 1979.
- U.S. Department of Interior. Management of transmission line rights-of-way for fish and wildlife. Volume 2. Eastern United States. U.S. Fish and Wildlife Service. FWS/OBS-79/22; 1979.
- U.S. Department of Interior. Management of transmission line rights-of-way for fish and wildlife. Volume 3. Western United States. U.S. Fish and Wildlife Service. FWS/OBS-79/22; 1979.

3.3 PRACTICES OR RECLAMATION TECHNIQUES USED TO ENHANCE AND/OR PROTECT FISH AND WILDLIFE RESOURCES

In this section, the operator will find a number of BCP's which facilitate restoration of disturbed areas for wildlife use as soon as possible following completion of mining. Other BCP's provide alternate reclamation approaches to enhance or provide new habitat for a desired wildlife group, e.g., fish, waterfowl.

3.3.1 Revegetation

- a. Use of the Plant Information Network (PIN) to aid in selection of revegetation plants.

PURPOSE

The Plant Information Network (PIN) is a computer-based service available to the public, developed to rapidly store, organize, and retrieve information on the native and naturalized vascular plants of several Western States. The PIN system data bank currently has ecological and economic information on approximately 5,000 plants found in Colorado, Montana, North Dakota, Wyoming, and Utah, and taxonomic, biological, and geographic distribution data for all species in the region.

DESCRIPTION OF THE SYSTEM

The information in the PIN data bank is in the form of "descriptors" and "descriptor states". Descriptors correspond to the attributes of the plants included in the system. Descriptor states represent the possible ratings a plant may have for a given descriptor. For example, high, medium, and low are the descriptor states for the descriptor LONG-TERM REVEGETATION POTENTIAL. PIN currently lists information on over 500 descriptors under the general headings of taxonomic, geographic, biologic, ecologic, and economic plant attributes. The taxonomic, geographic, and biologic descriptors have been stored for all plants in the data bank. Many of the ecologic and economic descriptors, however, have been examined only for plants identified as important for reclamation, rangeland, wildlife habitat, legal status, or other resource management concerns. These plants are referred to as "priority species."

The list of descriptors and descriptor states under the "economic" heading, shown in Table 3.3-1, indicates PIN's value in being able to identify potential plants for use in revegetating wildlife habitat and rangeland. Descriptors and descriptor states under the "ecologic" heading are also valuable as indicators of the growth requirements of each species.

USE AND AVAILABILITY

An example of the type of information that can be obtained by using the PIN system is shown in Table 3.3-2. Other types of information can also be

acquired, depending on what questions are asked. Staff members who handle PIN inquiries can help format these questions so that only the information specifically requested is received, eliminating the need for sorting through unnecessary data.

For more information about PIN contact the following address:

U.S. Fish and Wildlife Service
Division of Biological Services
Western Energy and Land Use Team
2627 Redwing Road, Drake Creekside One
Ft. Collins, Colorado 80526
phone: (303) 226-9388, FTS 323-5388

Table 3.3-1. List of Descriptor and Descriptor States under the General Heading of "Economic Attributes" in the PIN Data Bank*

Human Health and Food Value

HAYFEVER CAUSING (yes, maybe, no)
EDIBLE (yes, yes-qualified, no, poisonous)

Reclamation Planting

CULTURE (a text on planting requirements of a species)
EROSION CONTROL POTENTIAL (high, medium, low)^a
ESTABLISHMENT REQUIREMENTS (high, medium, low)^a
SHORT-TERM REVEGETATION POTENTIAL (high, medium, low)^a
LONG-TERM REVEGETATION POTENTIAL (high, medium, low)^a
WEEDINESS (noxious-CO, noxious-CO/MT, noxious-CO/MT/ND, noxious-CO/MT/ND/WY, noxious-CO/MT/WY, noxious-CO/ND, noxious-CO/ND/WY, noxious-CO/WY, noxious-MT, noxious-MT/WY, noxious-CO/WY, noxious-ND, noxious-WY, economic, colonizing, non-weedy)

Wildlife Values

Cover

ELK COVER VALUE (good, fair, poor)^a
MULE DEER COVER VALUE (good, fair, poor)^a
WHITETAIL DEER COVER VALUE (good, fair, poor)^a
ANTELOPE COVER VALUE (good, fair, poor)^a
UPLAND GAME BIRD COVER VALUE (good, fair, poor)^a
WATERFOWL COVER VALUE (good, fair, poor)^a
SMALL NON-GAME BIRD COVER VALUE (good, fair, poor)^a
SMALL MAMMAL COVER VALUE (good, fair, poor)^a

Table 3.3-1 (concluded)

Food Value

ELK FOOD VALUE (good, fair, poor)^a
MULE DEER FOOD VALUE (good, fair, poor)^a
WHITETAIL DEER FOOD VALUE (good, fair, poor)^a
ANTELOPE FOOD VALUE (good, fair, poor)^a
UPLAND GAME BIRD FOOD VALUE (good, fair, poor)^a
WATERFOWL FOOD VALUE (good, fair, poor)^a
SMALL NON-GAME BIRD FOOD VALUE (good, fair, poor)^a
SMALL MAMMAL FOOD VALUE (good, fair, poor)^a

Livestock Values

Palatability

CATTLE FORAGE PALATABILITY (good, fair, poor)^a
SHEEP FORAGE PALATABILITY (good, fair, poor)^a
HORSE FORAGE PALATABILITY (good, fair, poor)^a

Nutrition

ENERGY VALUE (good, fair, poor)
PROTEIN VALUE (good, fair, poor)

Toxicity

POISONOUS-LIVESTOCK (major, minor, mechanical injury, suspected, no)

*Descriptors are printed in capital letters, descriptor states in parenthesis.

^aDescriptors provide a separate rating for each of the five States in the system. For example, erosion control potential ratings can be obtained for a given plant that is specific to Colorado, Montana, North Dakota, Utah, or Wyoming.

Table 3.3-2. Possible Revegetation Species for Livestock Forage on Sandy Soils in Campbell County, Wyoming*

MEMO Infrspecific--

Infrspecific names refer to subspecies, varieties, or forms. When a plant has an infrspecific name, it is printed immediately after the species name. If no infrspecific name is recognized, the word "None" is printed. Occasionally, PIN obtains County records for plants which have not been keyed out to variety or subspecies. In such instances, the word "Unknown" is printed after the species name, indicating we are uncertain which infrspecies the record should be tied to*

MEMO Abbreviations used for origin descriptor states--

Austral = Australia-Pacific
North A = North America
South A = South America*

MEMO Abbreviations used for soil type descriptor states--

G = Good
F = Fair
p = Poor*

60

MEMO Abbreviations used for potential biomass production, erosion control potential, establishment requirements, short-term revegetation potential, and long-term revegetation potential descriptor states--

H = High
M = Medium
L = Low
V = Very Low*

MEMO Abbreviations used for poisonous-livestock descriptor states--

Mechani = Mechanical Injury
Suspect = Suspected*

COLUMNS 10,-2,36=3,-1,31,-1,7,-2,13,-2,1,-1,1,-2,7*

Print, habit, genus, species, infrspecific, common name, origin, habitat, growth on sand-WY, establishment requirements-WY, long-term revegetation potential-WY, poisonous-livestock for plants with Campbell-WY, present or reported and growth on sand-WY, good or fair and establishment requirements-WY, low or medium

Table 3.3-2 (continued)

and long-term revegetation potential-WY, good or fair and weediness-WY, high or medium and cattle forage palatability-WY, good or fair and weediness, non-weedy or colonizing and not poisonous-livestock, major*

Column Descriptors

- A = Habit
- B = Genus
- Species
- Infraspecific
- C = Common name
- D = Origin
- E = Habitat
- F = Growth on sand-WY
- G = Establishment Requirements-WY
- H = Long-term revegetation potential-WY
- I = Poisonous-livestock

List 38

Response

A	B	C	D	E	F	G	H	I
Forb	<u>Astragalus adsurgens</u>	Standing milkvetch	Native	Dry	F	L	M	No
	<u>robustior</u>							
Forb	<u>Ipomopsis spicata</u>	Spike gilia	Native	Dry	G	M	M	No
Forb	<u>Liatris punctata</u>	Dotted gayfeather	Native	Dry	G	M	M	No
Forb	<u>Medicago sativa</u>	Alfalfa	Europe	Moist	F	M	H	Minor
Forb	<u>Melilotus alba</u>	White sweetclover	Eurasia	Dry-Moist	G	L	M	Minor
Forb	<u>Melilotus officinalis</u>	Yellow sweetclover	Europe	Dry-Moist	G	L	M	Minor
Forb	<u>Trifolium repens</u>	White clover	Europe	Moist	F	M	M	Minor
Grasslike	<u>Agropyron cristatum</u>	Fairway wheatgrass	Asia	Dry-Moist	F	M	M	No
Grasslike	<u>Agropyron intermedium</u>	Intermediate wheatgrass	Europe	Dry-Moist	F	M	M	No
	<u>intermedium</u>							
Grasslike	<u>Agropyron spicatum</u>	Beardless bluebunch wheatgrass	Native	Dry	F	M	M	No
	<u>spicatum</u>							
Grasslike	<u>Andropogon scoparius</u>	Little bluestem	Native	Dry	F	M	H	No
	<u>scoparius</u>							

Table 3.3-2 (concluded)

A	B	C	D	E	F	G	H	I
Grasslike	<u>Bouteloua gracilis</u> None	Blue grama	Native	Dry	F	M	H	Minor
Grasslike	<u>Bromus inermis inermis</u>	Smooth brome	Eurasia	Dry-Moist	F	L	M	No
Grasslike	<u>Buchloe dactyloides</u> None	Buffalograss	Native	Dry	F	M	H	No
Grasslike	<u>Calamovilfa longifolia</u> None	Prairie sandreed	Native	Dry	G	M	H	No
Grasslike	<u>Carex eleocharis</u> None	Needleleaf sedge	Native	Dry	F	M	M	No
Grasslike	<u>Carex filifolia</u> None	Threadhead sedge	Native	Dry	F	M	M	No
Grasslike	<u>Carex heliophila</u> None	Sun sedge	Native	Dry	G	L	M	No
Grasslike	<u>Carex lanuginosa</u> None	Woolly sedge	Native	Wet	G	L	M	No
Grasslike	<u>Danthonia unispicata</u> None	Onespike danthonia	Native	Dry-Moist	G	M	M	No
Grasslike	<u>Elymus canadensis</u> None	Canada wildrye	Native	Dry-Moist-Wet	G	M	H	No
Grasslike	<u>Koeleria cristata</u> None	Prairie junegrass	Native	Dry	F	M	M	No
Grasslike	<u>Oryzopsis hymenoides</u> <u>hymenoides</u>	Indian ricegrass	Native	Dry	G	M	H	No
Grasslike	<u>Phleum pratense</u> None	Timothy	Europe	Moist	F	M	H	No
Grasslike	<u>Sporobolus airoides</u> None	Alkali sacaton	Native	Dry-Moist	F	M	M	No
Grasslike	<u>Sporobolus cryptandrus</u> None	Sand dropseed	Native	Dry	F	M	M	No
Grasslike	<u>Stipa comata comata</u>	Needle-and-thread	Native	Dry	G	M	H	Mechani
Grasslike	<u>Stipa viridula</u> None	Green needlegrass	Native	Dry	F	L	H	Mechani
Shrub	<u>Artemisia cana</u> Unknown	Silver sagebrush	Native	Dry-Moist	F	M	M	No
Shrub	<u>Artemisia cana cana</u>	Silver sagebrush	Native	Dry-Moist	F	M	M	No
Shrub	<u>Atriplex canescens</u> None	Fourwing saltbrush	Native	Dry	F	M	H	Minor
Shrub	<u>Ceratoides lanata</u> None	Common winterfat	Native	Dry-Moist	F	M	H	Minor
Shrub	<u>Rhus trilobata trilobata</u>	Skunkbush sumac	Native	Dry	F	M	M	Suspect
Shrub	<u>Ribes cereum</u> None	Wax currant	Native	Dry-Moist	F	M	M	No
Shrub	<u>Rosa woodsii</u> None	Wood's rose	Native	Dry-Moist	F	M	M	No
Shrub	<u>Symphoricarpos occidentalis</u> None	Western snowberry	Native	Moist	F	M	M	No
Shrub-Tree	<u>Prunus americana</u> None	American plum	Native	Dry-Moist	F	M	M	No
Shrub-Tree	<u>Salix amygdaloides</u> None	Peachleaf willow	Native	Wet	F	M	M	No

No. of items in query response = 38

No. of items in the data bank = 4297

Percentage of response/total data bank = .884

End*

US Fish and Wildlife Service
Office of Biological Services
Western Energy and Land Use Team
2625 Redwing Road, Drake Creekside One
Ft. Collins, Colorado 80526
phone: (303) 226-9389, FTS 323-5389

SOURCES OF INFORMATION

Additional References:

- Evans, G.; Vories, K. C. The plant information network: volume IV. A subject guide and annotated bibliography to selected literature on land reclamation and rehabilitation in the western United States. Ft. Collins, CO: Western Energy and Land Use Team, Off. of Bio. Serv. U.S. Fish and Wildlife Serv.; 1977.
- Vories, D. C.; Sims, P. L. The Plant Information Network: volume I. A user's guide. Ft. Collins, CO: Western Energy and Land Use Team, Off. of Bio. Serv. U.S. Fish and Wildlife Serv.; 1977a.
- Vories, K. C.; Sims, P. L. The Plant Information Network: volume II. Reclamation and PIN on northwestern Colorado. Ft. Collins, CO: Western Energy and Land Use Team, Off. of Bio. Serv. U.S. Fish and Wildlife Serv.; 1977b.
- Vories, K. C.; Sims, P. L. The Plant Information Network: volume III. Reclamation and PIN in Powder River Basin of Montana and Wyoming. Ft. Collins, CO: Western Energy and Land Use Team, Off. of Bio. Serv. U.S. Fish and Wildlife Serv.; 1977c.

Copies of publications can be obtained by contacting:

Publication Distribution Manager
U.S. Fish and Wildlife Service
Western Energy and Land Use Team
Drake Creekside One
2625 Redwing Road
Fort Collins, CO 80526
Commercial Telephone: (303) 226-9311
FTS: 323-5311

b. Fertilization.

PURPOSE

Fertilizers are added to the soil to supply one or more elements essential for plant growth. If the soil material contains less of a certain nutrient than is required for the initial establishment and maintenance of vegetation, fertilizers or other soil amendments are needed.

DEVELOPMENT

In semiarid regions, such as the Powder River-Fort Union Coal Region, nitrogen and phosphorus are the nutrients most often found deficient (Tucker and Day 1980). According to Barth (1977), 82% of the surface coal mines in the Northern Great Plains coal province were fertilizing with nitrogen and phosphorus in 1976. The typical method of fertilizing at these mines is by broadcasting, followed by disking, chisel plowing, harrowing, or some other treatment designed to incorporate fertilizer into the top 10 to 15 cm (4 to 6 in) of soil.

Deficiencies of other essential plant nutrients have seldom been recognized in mine spoils in the Northern Great Plains; however, research on this subject is limited. Power et al. (1978) reports that, in some areas, exchangeable magnesium levels may be high enough to restrict calcium uptake, even from soils containing 10% free calcium carbonate. Also, molybdenum levels in plants may occasionally be high enough to interfere with copper metabolism in livestock.

Two other problems should be considered before proceeding with fertilization:

- o The use of fertilizer may reduce the amount of water available for plant absorption, especially during the critical period of seed germination.
- o Fertilization at the time of seeding often benefits the annuals or weeds more than the seeded species.

The first problem can be solved by refraining from fertilizing or by deciding that the benefits of fertilizing outweigh the disadvantages of decreased water absorption. Delaying fertilization for one year may help solve the latter problem.

Scientists at the Northern Great Plains Research Center (NGPRC), which is operated by the USDA Agricultural Research Service in Mandan, North Dakota, have done extensive research on revegetation of spoils, including the correction of plant nutrient deficiencies. While phosphorus appears to be universally deficient in spoils of the Fort Union area, NGPRC investigators have determined that freshly exposed shales frequently contain exchangeable ammonium (a form of plant-available nitrogen) in quantities comparable to the nitrate-nitrogen (also a form of plant-available nitrogen) that is found in the upper

foot of cultivated soils in North Dakota. After exposure to weathering, the exchangeable ammonium is transformed to nitrate-nitrogen (U.S. Agricultural Research Service and North Dakota Agricultural Experiment Station 1977). Thus, depending upon the quantity of exchangeable ammonium present and plant needs, nitrogen may not be deficient in recently exposed spoils. The growth of nitrogen-fixing legumes will help to sustain the supply of plant-available nitrogen in such spoils.

NGPRC scientists have shown that tests developed over the last 25 years to determine soil nutrient deficiencies on unmined lands have proven useful on reclaimed mine soils also, whether the proposed land use is grazing or crop production. Before a fertilization plan, which includes rate and timing, can be formulated, a soil test should be made. In addition, the following factors should be considered:

- o what species of grasses, forbs, or shrubs are to be planted;
- o the available water supply in the rooting zone at seeding;
- o the thickness of the topsoil; and
- o whether an organic mulch will be used.

The use of native plants for revegetation has increased over the past five years. Native plants have evolved under conditions of infertile soils, often do not have high nutrient requirements, and may not require the same amount of fertilizer as introduced species. Another influence on amount of fertilizer is the water supply. What is the expected precipitation? Will supplementary water be used? Thickness of topsoil influences the potential yield of grasses (U.S. Agricultural Research Service and North Dakota Agricultural Experiment Station 1977) and should be considered when determining fertilization rate (see Section 3.2.1.a, General Procedures). In other words, topsoil of 4.7 cm (12 in) would require less fertilizer than topsoil of 1.6 cm (4 in). In addition, if organic mulch is used, nitrogen fertilization must be increased because 9.1 kg (20 lb) or more of nitrogen per 0.9 MT (ton) of mulch may be consumed or "tied up" by microbial metabolism as the mulch decomposes.

To correct a phosphorus deficiency, P_2O_5 (phosphorus pentoxide) is added at a recommended rate of 89.1 kg/ha (100 lb/acre) on coarse-textured soils and 178.2 kg/ha (200 lb/acre) on fine-textured clay soils (U.S. Forest Service 1979). (This is a general figure, and specific rates should be determined by laboratory analyses of soil material from the site in question.) Because phosphate-phosphorus is not water soluble, it must be incorporated into the root zone to be effective. In semiarid regions, the best results are obtained if the soil is treated prior to seeding. Phosphorus fertilization has a long-lasting effect and the soil/spoil may need only one application.

Nitrogen fertilizer, applied at 35.6 to 44.5 kg/ha (40 to 50 lb/acre), may be necessary to correct a nitrogen deficiency. With straw mulch, this amount would have to be doubled (U.S. Forest Service 1979). If seeding is

done in the late fall, nitrogen should be applied after germination in the spring. In spring, nitrogen can be applied at the time of seeding, before expected moisture, if possible. As mentioned above, if annual weeds are a problem, nitrogen may be applied at the beginning of the second growing season to avoid fertilizing the weeds. Nitrogen is water soluble and can be spread on the soil surface. Nitrogen availability is more short-term than phosphorus, and more than one application may be required.

Nutrient deficiencies can be corrected by the application of fertilizer in the form of ammonium nitrate, phosphoric acid, and potash. These compounds provide nitrogen, phosphorus, and potassium, respectively. These compounds can be obtained as a straight fertilizer containing only one compound or as a mixed fertilizer which contains two or all three nutrients. Fertilizers are identified by percentage analysis of the three major nutrients. An analysis of 0-46-0 indicates that this fertilizer is concentrated superphosphate and provides only phosphorus at a percentage of 46% by weight (100 kg [220 lbs] of fertilizer contains 46 kg [101 lbs] of phosphorus).

Likewise, a fertilizer with an analysis of 10-10-10 provides 10 kg (22 lbs) each of nitrogen, phosphorus, and potassium per 100 kg (220 lbs) of fertilizer. Minimum rates of fertilization are required by some State regulation agencies.

For more information on types of fertilizers, rates, and methods of fertilization, see the publications under "Additional References."

MAINTENANCE AND MANAGEMENT

Proper seedbed preparation greatly increases the chances of successful revegetation. If vegetation begins to fail during the bonding period, the affected areas should be checked for nutrient deficiencies. Refertilization may be necessary to correct these conditions.

Nitrogen may have to be added every two or three years on certain nitrogen-deficient soils. If the vegetation on reclaimed areas is a light green color and/or there is a substantial reduction in ground cover, nitrogen fertilization should be considered.

LABOR/MATERIALS

The amount of effort required to prepare a seedbed depends on site conditions, such as soil compaction, size and quantity of rocks, slope, and length of time since final grading. These conditions, in addition to the size of the area, will dictate the type of equipment and the number of hours of equipment time required for tilling.

Soil amendments can be performed by a number of methods. Application costs vary depending upon method and terrain. A particularly rough area may require many man-hours of hand labor, but only one hour of aircraft time. Combining the application of fertilizer with seeding by using a hydroseeder or dry-application blower can reduce costs considerably.

Phosphorus is added prior to seeding, while nitrogen may be added during seeding, which reduces labor costs. A spreader can be mounted on a trailer or a truck and driven or pulled near the area to be treated. For steep, rough terrain or a confined area, a fertilizer blasting gun may be used. The blasting gun is hand-held and connected to a portable air compressor which should allow fertilizer granules to be sprayed up to 23 m (75 ft) if maintained at a pressure of 1,278 to 1,420 kg/cm² (90 to 100 lb/in²). For more information on equipment for fertilization, see the catalog of revegetation equipment by Larson (1980).

Material and labor costs for fertilization can be reduced by using fertilizers with high nutrient analyses. This reduces unnecessary handling of often unneeded bulk by allowing specific fertilizer requirements to be fulfilled.

The cost of a 22.7 kg (50 lb) bag of phosphorus (0-46-0), which contains 10.4 kg (23 lbs) of phosphorus, is approximately \$15. To apply 89.1 kg phosphorus/ha (100 lb/acre) would require 194 kg (430 lbs) of 0-46-0 fertilizer at a cost of \$129/ha (\$52/acre). Nitrogen applied as ammonium nitrate (33-0-0) costs \$12/22.7 kg (50 lb). An application of 44.5 kg/ha (50 lb/acre) would require 134 kg (295 lbs) of 33-0-0 fertilizer at a cost of \$70.80/ha (\$28.66/acre).

SOURCES OF INFORMATION

- o State Regulatory Authority
- o Office of Surface Mining
- o North Dakota Agricultural Experiment Station
- o USDA Northern Great Plains Research Center
- o Soil Conservation Service
- o Montana Agricultural Experiment Station
- o Wyoming Agricultural Experiment Station

For addresses, see Appendix A.

References Cited:

- Barth, R. C. Reclamation practices in the Northern Great Plains coal province. *Mining Cong. J.* 63(5):60-64; 1977.
- Larson, J. E. Revegetation equipment catalog. USDA Forest Service Equipment Development Center, Missoula, MT 59801; 1980. p. 83-87.
- Power, J. F.; Ries, R. E.; Sandoval, F. M. Reclamation of coal-mined land in the Northern Great Plains. *J. of Soil and Water Conservation* 33(2):69-74; 1978.
- Tucker, T. C.; Day, A. D. Vegetative reclamation of mine wastes and tailings in the Southwest. Brittain, R. G.; Myhman, M. A., eds. 1980 April 23-25; Mine Reclamation Center, U. of Arizona, Tucson, AZ; 1980. p. 7-1 to 7-3.

U.S. Agricultural Research Service and North Dakota Agricultural Experiment Station. North Dakota progress report on research on reclamation of strip-mined lands - update 1977; 1977. p. 17-19.

U.S. Forest Service. User guide to soils. USDA For. Serv. Gen. Tech. Rep. INT-68. Intermt. For. and Range Exp. Stn., Ogden, UT 84401; 1979. 85 p.

Additional References:

Soil Improvement Committee, Calif. Fertilizer Assn. Western fertilizer handbook. Danville, IL: Interstate Printers and Publishers, Inc.; 1975.

Tisdal, S. L.; Nelson, W. L. Soil fertility and fertilizers. New York, NY: MacMillan Publications; 1975.

c. Seeding.

PURPOSE

For the Powder River-Fort Union Coal Region, the major post-mining land uses will be grazing of livestock and wildlife and raising crops. In considering wildlife habitat as an important land use, the primary revegetation goal is to produce hardy, drought resistant plants which will provide food or cover for various wildlife species. However, in North Dakota, such a practice may be contrary to the general, preferred land use. In this area, consideration should be given to wildlife habitat restoration when habitat is destroyed by mining.

DEVELOPMENT

Much consideration is being given to the use of native species in designing seed mixtures. Native species are adapted to local climatic conditions and introduced species in general possess a wider range of adaptation to soils and climate. In Montana, studies (DePuit et al. 1980) have shown that when mixtures of native and introduced species are used, the plant community is dominated by a small number of vigorous, highly productive introduced species, even if these varieties comprised only a small percentage of the seed mixture. Berg (1975) recognized that communities on reclaimed mined lands, when dominated by certain introduced species, would be best used for grazing pastures; whereas, lands reclaimed with more diverse, native plant species would be better for more general grazing and diversified wildlife habitat. In any case, the State regulatory authority will be the final decision maker on the adequacy of the operator's proposed seed mixture.

However, producing a climax community from seed may not be realistic. A more attainable goal would be to produce a successional stage that is easier to establish, which will then gradually change toward the expected climax community. Because the soil has been altered to some degree in a reclamation project (it is impossible to replace the soil profile exactly as it was), the suitability of the area for preexisting plant species may be radically affected (Moore et al. 1977). The best adapted inhabitants of these disturbed environments are annual grasses and forbs, including introduced species. Few of the original native species will be capable of reestablishing themselves because they belong to a more advanced successional stage than a newly disturbed mine site can provide.

In developing a seed mixture for a specific site, the following considerations are important: soil conditions; micro-climate; slope; aspect; and water availability. To prepare a mixture of predominantly native species, seed availability, successional stages of surrounding plant communities, and wildlife and livestock food and cover values are all important factors. Seed mixtures can be site specific or can be used for a certain ecotype, such as woody draws or steep uplands.

Selection of native species for seeding is dependent upon availability of seeds that are adapted to the soil and climate of the mine site. Seeds of

many species are available commercially from collectors and seed companies. Seeds of some native plant species must be collected from native stands, since reliable commercial seed production techniques have not been developed for all species.

Seed production from wildland populations can be unpredictable from year to year (Institute for Land Rehabilitation 1979). Low precipitation, frost, insect damage, disease, and grazing can lower seed quality or even prevent production. Thus, most native species produce abundant seed crops only in favorable years.

Methods of Seeding

An important problem in reclaiming western coal lands is that both native and introduced species may require amounts of water beyond natural precipitation levels (see Section 3.3.1.a, Water Conservation). The method of seeding is also important. Seeds need to be planted at proper depths with as much conservation of moisture as possible.

Drilling and broadcasting are the two most commonly used methods of seeding in the West. Both drilling and broadcasting can be done by machines or by hand. Drilling is considered the superior method of seeding where site conditions permit; however, in some cases, the site may be accessible only for a specific type of broadcast seeding. Barth (1977) studied 17 existing surface coal mines and found that a rangeland seed drill was used at 94% of the mines. Seeding depths range from 1.3 to 3.8 cm (0.5 to 1.5 in).

The following table lists the advantages and disadvantages of broadcasting and drilling.

Table 3.3-3. Seeding methods - Advantages and Disadvantages (from Cook et al. 1974; Deput and Dollhopf 1978; Frischknecht and Ferguson 1979; Benally 1980).

	<u>Advantage</u>	<u>Disadvantage</u>
Broadcasting	<p>Lower cost</p> <p>Applicable to small, rough or steep sites</p> <p>Useful for seed mixtures with variable size, weight, structures</p> <p>Faster method of seeding</p>	<p>Seed desiccation if proper depth not achieved</p> <p>Uneven soil coverage</p> <p>More seed per unit area</p> <p>Loss of seed to rodents can be great</p> <p>Seed planting very variable and loss of seed to wind can be great</p>
Drilling	<p>Applicable to mulched surfaces</p>	<p>Restricted to smooth sites with gradual slopes</p>

Table 3.3-3 (concluded)

<u>Advantage</u>	<u>Disadvantage</u>
More uniform planting depth and resultant stands of seeded plants	Slower Higher cost
More rapid production of seeded plants	Requires more intensive seed bed preparation
Less seed per unit area	All seeds planted at same depth regardless of requirements

In general, broadcast seeding has traditionally taken twice the amount of seed as drilling (Cook 1974). In a recent study by DePuit et al. (1980), which compared both methods of seeding native species, initial establishment of seedlings was somewhat slower under broadcasting than drilling, but the ultimate (2 to 3 years) plant densities were similar under equal seeding rates.

As more complex mixtures of seeds of many different sizes are developed, drilling has become less efficient. Broadcast seeding, when preceded by a chisel plow (see Section 3.3.1.g, Water Conservation) and followed by a culti-packer, chain, drag bar, or spike tooth harrow to cover the seed, or when broadcasting follows a land imprinter, is an economical and productive alternative to drilling.

A hydroseeder is an alternative broadcast method that applies seed and mulch by means of a high-pressure stream of water and is an especially fast, efficient method of seeding steep, hard-to-reach areas. Disadvantages are that large amounts of water must be available, the seed may be held off the ground by the mulch fibers, many seeds may be damaged by the agitators and pump, and seed may germinate due to water in mulch but die before the root system can be established in the soil. For more information on types of broadcast and drill seeders, consult the USDA Forest Service Revegetation Equipment Catalog (Larson 1980).

Seeding of Shrubs

The seeding of shrubs, although an economical practice, has been limited in the past by unavailability of seed and a lack of understanding of seeding techniques. Crofts and McKell (1977) can be consulted for a list of seed and planting material sources in the Western States. Most States have a similar list, which is usually available from the Soil Conservation Service field offices and/or the regulatory authority. Plummer et al. (1968) provides data on the establishment requirements of shrubs, particularly for species important to big game.

Shrub seeds usually require a longer period of stratification (exposure to moisture and low temperature) than do seeds of most herbs. Consequently, shrub seedling growth is often suppressed by the more robust herbs. According to Crofts and Parkin (1979), an acceptable shrub seedling density can be obtained when planted at a rate of about six to ten seeds per 0.093 m² (1 ft²), even when seeded with highly competitive grasses and forbs.

Seeding Rates

Rate of seeding depends on seed quality. In order to account for quality, seeding rates should be expressed as pure live seed (PLS). PLS refers to the amount of live seed of the desired species in a bulk lot. An example given by Cook et al. (1974) is that if an order for 147.7 kg (325 lbs) of grass seed had 90% germination and 95% purity rates, the PLS would be 85.5% or 126.3 kg (278 lbs) pure live seed ($.90 \times .95 \times 147.7 = 126.3$).

There are several factors that influence the rate of seeding. As discussed, broadcasting usually requires more seed than drilling. Poorer sites require more seed than favorable sites. West and south slopes should have the quantity of seed increased by 50 to 100%. For a small-seeded species, fewer pounds per acre are required because of the greater number of seeds per pound.

Season of Planting

In the Powder River-Fort Union Coal Region, either mixtures of grasses and legumes or cool season grasses alone are suited to late summer seeding (National Academy of Sciences 1974). Warm season species should be seeded in the spring just prior to the period of the most favorable growing conditions, usually April.

Seeding a mixture of both cool and warm season species presents a problem. The decision on when seeding is most appropriate for this kind of mixture should be based on the dominant species being planted and the preceding and current climatic conditions. Late fall seedings are best when mixtures of grasses, forbs, and shrubs are used because the winter period provides stratification of the seed (Cook et al. 1974).

MAINTENANCE AND MANAGEMENT

Management of seeded areas may require fertilization or supplemental watering, depending on the site conditions. Choosing species with self-generating, long-lived, disease-resistant, and pest-resistant characteristics will lessen the amount of maintenance required.

LABOR/MATERIALS

There is a wide range of seeding equipment on the market from aircraft spreaders to seed dribblers to rangeland drills. Space does not allow even a brief description of all the possible seeders, but more information is available from the USDA Forest Service Revegetation Equipment Catalog (Larson 1980).

Seed sources are listed in Hinkle et al. (1981) or can be obtained from the State regulatory authority.

The cost of seeding mixtures will vary tremendously, depending on availability of seed, amount of seed used, and species selected. Crofts and Parkin (1979) compared costs of seeding and transplanting shrubs by extrapolating data from the Colowyo Mine and the Energy Fuels Mines. The cost of each shrub established from seeding ranged from \$0.001 to \$0.031 per plant, while transplanting one shrub using modified front end loaders, based on an expected 70% survival rate, is \$9.89 per surviving seedling. Projected costs for reestablishing shrub densities on surface-mined land using different planting methods are summarized in Section 3.3.1.d, Transplanting Native Vegetation. The cost variation for transplanting is tremendous; this makes seeding an attractive method of shrub propagation.

SOURCES OF INFORMATION

- o State Regulatory Authority
- o Office of Surface Mining
- o U.S. Forest Service, Rocky Mtn. Forest and Range Experiment Station
- o U.S. Forest Service, Intermountain Forest and Range Experiment Station
- o U.S. Forest Service - Equipment Development Center
- o U.S. Soil Conservation Service
- o USDA High Plains Grasslands Research Center
- o State Agricultural Research Stations

For addresses, see Appendix A.

References Cited:

- Barth, R. C. Reclamation practices in the Northern Great Plains coal province. *Mining Cong. J.* 63(5):60-64; 1977.
- Benally, R. Seed drilling and broadcasting. Brittain, R. G.; Myhrman, M. A., eds. *Vegetative reclamation of mine wastes and tailings in the Southwest*; 1980 April 23-25, Tucson, AZ. Mine Reclamation Center. Arizona Mining and Mineral Resources Research Institute; 1980. p. 13-1 to 13-5.
- Berg, W. A. Revegetation of land disturbed by surface mining in Colorado. Wali, M. K., ed. *Practices and problems of land reclamation in western North America*. Fargo, ND; University of North Dakota Press; 1975.
- Cook, C. W.; Hyde, R. M.; and Sims, P. L. *Revegetation guidelines for surface mined areas*. Colorado State University Science Series No. 16; 1974.
- Crofts, K. A.; McKell, C. M. *Sources of seeds and planting materials in the Western States for land rehabilitation projects - emphasizing native plant species*. Utah Agricultural Experiment Station, Land Rehabilitation Series No. 4; 1977.

- Crofts, K. A.; Parkin, C. A. Methods of shrub and tree establishment on strip mined lands in northwest Colorado. Symposium on surface coal mining and reclamation. Coal Conference and Expo V; 1979 October 23-25; Louisville, KY: McGraw-Hill, New York; 1979.
- DePuit, E. J., Coenenberg, J. G.; Skilbred, C. L. Establishment of diverse native plant communities on coal surface-mined lands in Montana as influenced by seeding method, mixture and rate. Montana Agr. Exp. Sta., Bozeman; Research Report 163; 1980.
- DePuit, E. J.; Dollhopf, D. J. Revegetation research on coal surface-mined lands at West Decker Mine, Decker, MT: Progress Report 1975. Montana Agr. Exp. Sta., Bozeman; Research Report 133; 1978.
- Hinkle, C. R.; Ambrose, R. E.; Wenzel, C. R. A handbook for meeting fish and wildlife information needs to surface mine coal. OSM Region 5, Washington, D.C.; USFWS FWS/OBS-79/48.3.5; 1981.
- Frischknecht, N. C.; Ferguson, R. B. Revegetating processed oil shale and coal spoils on semi-arid lands; interim report. Office of Research and Development, U.S. EPA; EPA-600/7-79-068; 1979.
- Institute for Land Rehabilitation. Selection, propagation, & field establishment of native plant species on disturbed arid lands. Utah Agricultural Exp. Sta. Bull. 500; 1979.
- Larson, J. E. Revegetation equipment catalog. USDA Forest Service Equipment Development Center, Missoula, MT; 1980.
- Moore, R. T.; Ellis, S. L.; Duba, D. R. Advantages of natural successional processes on western reclaimed lands. Paper presented at the 5th Symposium on surface mining and reclamation. Louisville, KY; 1977.
- National Academy of Sciences. Rehabilitation potential of western coal lands. Study Committee on the potential for rehabilitating lands surface mined for coal in the western United States. Cambridge, MA: Bullinger Publishing Company; 1974.
- Plummer, A. P.; Christensen, D. R.; Monsen, S. B. Restoring big game range in Utah. Utah Div. of Fish and Game Publ., 68-3; 1968.

Additional References:

- Everett, W. Sources of seed and plant stock. Vegetative Rehabilitation and Equipment Workshop. USDA Forest Service Equipment Development Center, Missoula, MT; 1981.

d. Transplanting native vegetation.

PURPOSE

In addition to being valuable in a situation where seeding is likely to fail, the transfer of existing vegetation from an area not yet mined to a location ready for planting offers the following advantages:

- o The vegetation is growing in the area and is already adapted to the site-specific environmental factors.
- o The soil-vegetation unit contains a portion of the soil profile and community, including the varied soil microorganisms (e.g., mycorrhizae) that enhance the health of the plants.
- o Food and cover for wildlife are provided.
- o The mature plants immediately provide seed sources and centers for vegetative reproduction, which hasten the revegetation of the surrounding area.
- o Species that cannot be effectively seeded or planted as nursery stock can be transplanted.
- o Patches of native vegetation can enhance the aesthetic value of the site.

DEVELOPMENT

Woody Vegetation

Two different methods are being used for transplanting native woody vegetation in the arid West. One is a tree spade which is mounted on a front-end loader. This can be used with a transport trailer (Larson and Knudson 1978; U.S. Forest Service 1980b). The tree spade has been tried at the Glenharold, Edna, Energy, Trapper, and Western Energy Mines, but is in regular use only at the Western Energy Mine. The other method is to use a front end loader (FEL), for which two modified transplant buckets have been developed (Frizzell et al. 1980; Larson 1980; U.S. Forest Service 1980a; Carlson et al. 1981). Use of a FEL with a transplant bucket has a large advantage over other methods because FEL's are widely used at all western surface mines and operate effectively on rocky soils where tree spades do not.

Tree Spade

The tree spade is designed to dig and transplant trees and shrubs with a minimum of root damage and is widely used in the nursery business. The plants are transplanted in a ball of soil that remains undisturbed and keeps the roots intact. Tree spades are available in three- or four-blade models, the former usually operating faster and the latter able to dig deeper. The blades are lowered into the ground hydraulically to form a soil ball which can be

transported in the spade or loaded onto a truck or trailer. Trees up to 7.6 cm (3 in) in diameter have been transplanted on mined lands. Leveling devices ensure that the tree is upright in the transplant hole. For use on mined lands, the spade can be mounted on trucks, tractors, trailers, or FEL's. Limitations include:

- o Use of the tree spade is restricted to slopes of less than 15% to ensure adequate depth of the soil ball and adequate roots on the downhill side.
- o The tree spade can be used only on sites with few rocks so that the spade can dig effectively.
- o The spade cannot be used on species with long tap roots.
- o Transportation distance should be less than 1.6 km (1 mi) due to the travel time needed; if distances are greater than 1.6 km (1 mi), then a transport trailer should be used.
- o Tree spades are more expensive than the use of FEL's (see Table 3.3-4).

The restriction of use to sites with virtually no rocks poses severe limitations on utility of the tree spade.

More information on the use of the tree spade for transplanting woody plants on disturbed western lands can be found in Dressler and Knudson (1976), Larson (1980), Larson and Knudson (1978), Jensen and Hodder (1979), and USDA Forest Service (1980b).

An experimental transplant system using a FEL mounted tree spade plus a transport trailer has been developed and tested by the U.S. Forest Service Equipment Development Center in Missoula, MT (Figure 3.3-1). A Vermeer Model TS-44A Tree Spade (four-blades) mounted on an articulated FEL was developed and used along with a specially built trailer that carries eight trees or shrubs. The tree transport truck consists of two rows of four cone-shaped pods. A crew of three is required, one to operate the FEL-spade, one working on the ground, and one driving the truck-trailer. Detailed information can be found in Larson (1980), Larson and Knudson (1978), and USDA Forest Service (1980b).

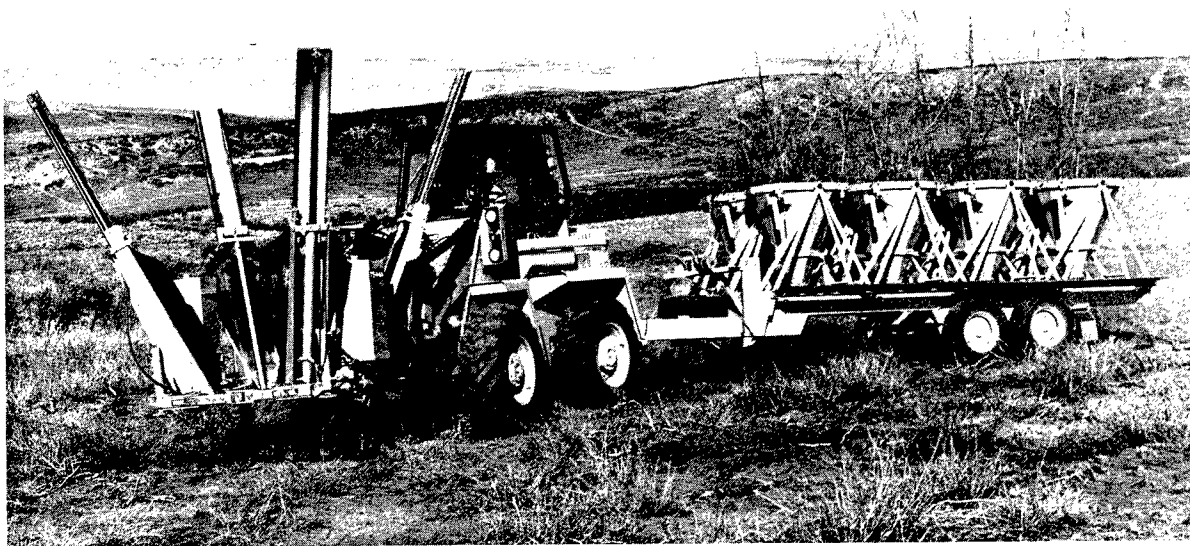

Figure 3.3-1. Tree spade and transporter (photo courtesy of USDA Forest Service).

Front End Loader

Three kinds of FEL buckets are used for transplanting shrub and tree pads on western mined lands. Coal buckets have been used successfully for several years in northwest Colorado (Crofts and Parkin 1979) and near Colstrip, MT (Sindelar et al. 1973; Jensen and Hodder 1979). Two buckets have been developed specifically for transplanting mature vegetation. An experimental unit was developed by the Missoula Equipment Development Center with funds from the Bureau of Land Management (Larson 1980; U.S. Forest Service 1980a) (Figure 3.3-2), and the other bucket was designed by Colorado State University (CSU) in cooperation with Energy Fuels Corporation (funded by the Bureau of Mines) (Frizzell et al. 1980; Carlson et al. 1981). The CSU bucket is used regularly at the Energy Fuels mine in northwest Colorado. The two transplant buckets have several characteristics in common.

- o Each bucket has straight rear and side walls so that tall plants can stand upright without being injured.
- o The load-carrying surface area of the bucket has been increased as compared to coal buckets.
- o A friction-reducing material has been applied to the bottom of the bucket so that the soil pad will slide smoothly and not break.

- o Each bucket is capable of picking up a soil pad at least 30 cm (12 in) thick.
- o Excavation is done by removing a "slice" parallel to the ground surface.
- o The bucket is unloaded by tilting it forward while the loader backs up.
- o They can move large shrubs as well as small trees (the CSU bucket, for instance, moves trees well over 15 cm [6 in] in diameter and up to 12 m [40 ft] high when operated by an experienced person).
- o Each unit is attachable to a variety of FEL's. (The Missoula Equipment Development Center, for instance, has drawings for adaptors for four FEL'S.)

The two buckets differ in surface area, shape, and method of control.



Figure 3.3-2. Front end loader and transplant bucket (photo courtesy of U.S. Forest Service).

A FEL used for transplanting is most effective when operated over short distances (less than one mile). At greater distances, travel times are excessive and wear and tear on the machine is great. In order to overcome this limitation, a transporter has been designed and used with the FEL bucket developed at CSU. The transporter moves the soil-vegetation pads more efficiently than the FEL and cuts down on the total time needed for the transplanting operation. Thus, the FEL would be used for a short time to remove a large number of clumps of vegetation from the undisturbed premined land and would then be free to again be used in mine production work. The transporter is a modified Hesston haystack mover that can pick up the stored vegetation clumps, move them to the planting site, and place them on the ground. The transporter is less expensive to operate and lower in initial cost than the FEL, and can be pulled by a variety of equipment (Frizzell et al. 1980).

The success of the transplants depends upon a variety of factors, the most important one being the lag time between transplanting and topsoiling around the exposed roots. To maximize survival, the exposed root pad must be backfilled as soon as possible after transplanting. Other factors include the species, size of the plants, soil moisture, distance travelled, experience of the operator, and location of the transplant. Guidelines for locating the transplant pads are discussed in Carlson et al. (1981). Considerations include plant species characteristics, site characteristics (e.g., topography, wind, and snow accumulation), and clump configuration and size (e.g., a number of pads placed together protect the inner plants from drying winds and damage due to wildlife use).

In general, shrubs should be planted in patches rather than uniformly, and the open areas (between patches) should be seeded with a shrub mix. A revegetation pattern of shrub patches interspersed with grass and forb stands will provide an area far more valuable as wildlife habitat (see Section 3.3.3.b, Planting Patterns to Increase Wildlife Diversity, and Section 3.3.3.a, Creating Topographic Features). Sites such as lowlands, drainages, depressions, north-facing slopes, and sheltered sides of topographic features are preferred sites for reestablishing shrub patches.

Sprigger

The sprigger developed by the Missoula Equipment Development Center is designed to gather bareroot, rhizomatous (i.e., with spreading, underground, horizontal stems) shrubs for transplanting. The shrubs are first mowed, and then the sprigs are gathered, separated from the soil, and carefully spread and covered with soil in the reclamation area. The sprigger can quickly gather a large number of shrubs for transplanting. In preliminary tests, it planted one quarter acre per day. Since mature, entire plants are not moved, sprigging does not provide the six advantages cited in the purpose section. A severe limitation on the use of the sprigger is its inability to separate roots from soil in heavy textured soils. It is still in the experimental stage.

More information is available from the Missoula Equipment Development Center (Fort Missoula, Missoula, MT 59801), Larson (1980), and U.S. Forest Service (1980c).

Herbaceous Vegetation

Transplanting of native herbaceous vegetation may be accomplished with the Missoula Equipment Development Center Dryland Sodder (i.e., a FEL with a modified bucket). Equipment and techniques specifically designed for transplanting grasses and herbs have been used on various disturbed western lands over the last 75 years (see Bunin et al. 1980 for a review of dry land sodding in the Northern Great Plains). A commercial sod cutter has been successfully used for several years at the Western Energy Mine in Colstrip, MT (Chris Cull, Western Energy, pers. comm., March 31, 1980) to revegetate reconstructed drainages where erosion is a potential problem. In order to ensure integrity of the relatively thin soil pad cut by commercial sod cutters, the vegetation must form a dense root mat in the top few centimeters (inches) of soil and the soil must be relatively rock-free.

At the Western Energy Mine, sod is cut into pieces 5 to 6 cm (2 to 2.5 in) deep, 45 cm (18 in) wide, and up to 8 m (25 ft) long with a commercial cutter. The pieces are rolled, transported immediately on a flatbed truck, and laid down with their long axes parallel to the contours. In critical areas, continuous rows of sod are laid with small overlaps, 3 to 4 cm (1.5 to 2 in), facing downhill, which aids the survival of the sod. Critical areas are identified by observations of runoff during a storm. Patches of sod are also used in other parts of drainages and are spaced 30 to 60 m (100 to 200 ft) apart. Sodding, done as early in the spring as possible, usually starts mid-April to May and ends by July 1. If the sod is dry, a hydroseeder is used to wet the sod the night before cutting. The sod takes approximately three weeks to bind to the soil sufficiently to withstand a normal runoff event. During this early period, a commercial product, Roll-lite, should be laid over the sod to protect the turf from water erosion.

MAINTENANCE AND MANAGEMENT

None of these methods of transplanting native vegetation depends upon supplemental watering or other care for their success. However, an initial watering immediately after transplanting is important for transplant survival. Protection from grazing and rodent damage is advisable (see Section 3.3.1.j, Pest Control, and Section 3.3.1.h, Grazing Management to Allow Vegetation Recovery).

The survival rate of the transplants depends upon a number of factors such as: rooting characteristics; environmental tolerances; soil moisture; precipitation and temperatures following transplanting; distance between sites; similarity of sites; and management practices.

Equipment maintenance is simplest in the case of the FEL since it is normally used as a part of routine mining activities. If a new piece of equipment is being used at a mine, additional maintenance is necessary. The tree spade-transport trailer system, the transporter used with a FEL, the sprigger, the commercial sod cutter and additional pieces of equipment would require additional maintenance time and expense.

LABOR/MATERIALS

All methods of transplanting native vegetation are far more expensive than seeding. In 1980, the use of a commercial sodder for transplanting small areas of grassy vegetation cost the equivalent of about \$54,340/ha (\$22,000/acre) (Chris Cull, Western Energy, pers. comm., March 31, 1980). A cost comparison for use of five methods of establishing woody plants is presented in Table 3.3-4. These figures are based upon the cost of the plant stock, equipment, labor, and survival rate of the transplants.

Table 3.3-4. Projected Costs Required to Reestablish Shrub Densities on Surface Mined Lands in Northwestern Colorado (modified from Crofts 1981)

<u>Cost/0.4 ha (Acre) of Various Shrub Planting Methods</u>				
<u>Seeding</u>	<u>FEL</u>	<u>Bareroot</u>	<u>Tree Spade</u>	<u>Containerized</u>
\$0.031/plant	\$3.37/plant	\$8.91/plant	\$28.14/plant	\$42.35/plant

SOURCES OF INFORMATION

- o State Regulatory Authority
- o Office of Surface Mining
- o State Agricultural Experiment Stations
- o USDA Forest Service Equipment Development Center

For addresses, see Appendix A.

References Cited:

- Bunin, J.; Hackos, J.; Harthill, M. The feasibility of dry land sodding for mined land reclamation. Prepared for U.S. Bureau of Mines, Denver, CO; 1980.
- Carlson, K.; Smith, J.; Crofts, K. Transplanting mature vegetation in mine reclamation. Presented before the American Society of Agricultural Engineers; 1981 March 20-21; Laramie, WY. St. Joseph, MO: American Society of Agricultural Engineers; 1981.
- Crofts, K. The nonconcept of species diversity and woody plant density as revegetation success standards. Proceedings of the Northwest Colorado Land Reclamation Seminar II. 1981. In press. To be published by Colorado State University Extension Service.

- Crofts, K.; Parkin, C. Methods of shrub and tree establishment on strip mined lands in northwest Colorado. Paper presented before the symposium on surface coal mining and reclamation. Coal Conference & Expo V: Louisville, KY. McGraw-Hill, NY; 1979.
- Dressler, R.; Knudson, R. Evaluation of Vermeer Model TS-44A Tree Spade for transplanting trees on surface mined land. Missoula, MT. USDA Forest Service Equipment Development Center; 1976. Available from: USDA Forest Service, MEDC, Missoula, MT.
- Frizzell, E.; Smith, J.; Crofts, K. Transplanting native vegetation. Staff-US Bureau of Mines. Proceedings of Bureau of Mine technology transfer seminars, surface coal mining reclamation equipment and techniques. 1980 June 3-5; Evansville, IN and Denver, CO. U.S. Bureau of Mines Information Circular 8823; 1980.
- Jensen, I.; Hodder, R. Tubelings, condensation traps, native tree transplanting and root sprigging techniques for tree and shrub establishment in semiarid areas. Montana Agricultural Experiment Station Research Report 141; 1979. 105 p.
- Larson, J. Revegetation Equipment Catalog. Missoula, MT. USDA Forest Service Equipment Development Center; 1980.
- Larson, J.; Knudson, R. A transplant system for revegetating surface mined land. Missoula, MT. USDA Forest Service Equipment Development Center; 1978. Available from: USDA Forest Service, MEDC, Missoula, MT.
- Sindelar, B.; Hodder, R.; Majcrus, M. Surface mined land reclamation research in Montana. Montana Agricultural Experiment Station Research Report 40; 1973. 122 p.
- U.S. Forest Service. Dryland sodder. Missoula, MT. USDA Forest Service Equipment Development Center; 1980a.
- U.S. Forest Service. Transplanting system. Missoula, MT. USDA Forest Service Equipment Development Center; 1980b.
- U.S. Forest Service. Sprigger. Missoula, MT. USDA Forest Service Equipment Development Center; 1980c.

e. Transplanting nursery grown plants.

PURPOSE

The use of young woody plants that have already germinated in the controlled conditions of a nursery can greatly increase the chances for successful mined land revegetation in situations where seeding is likely to fail. Seeding may be unsatisfactory for one or more of the following reasons:

- o The site is so dry that germination and establishment are poor.
- o Soil erosion or slope instability is critical.
- o Rapid vegetation establishment is required.
- o Seeds for desired species are not available.
- o A desired species will not reproduce satisfactorily by seed at the mine site but may reproduce by seed or by vegetative propagation in the controlled conditions of a nursery.

From the perspective of wildlife habitat enhancement, any procedure that recreates desirable food and cover rapidly and reliably is advantageous.

DEVELOPMENT

A comparison of seeding and transplanting is shown in Table 3.3-5. Although transplanting is far more expensive than seeding, transplanting offers several substantial advantages in terms of wildlife habitat restoration.

Table 3.3-5. Comparison of Seeding and Transplanting Nursery Grown Stock.

<u>Seeding</u>	<u>Transplanting</u>
Probability of success is lower due to the vulnerability of the young seedlings to frost and drought.	Likelihood of higher survival rates, especially on arid sites or where erosion is a potential problem.
	Makes possible establishment of species for which abundant seed is not available.
	Improves probability of successful establishment for species with low germination rates and poor establishment characteristics.

Table 3.3-5 (concluded)

Seeding	Transplanting
Techniques have been relatively well worked out and are usually simpler.	Preparatory storage and planting of stock is more laborious.
Far less expensive.	In northwest Colorado, each established shrub plant costs on the order of 25 to 50 times the seeding cost (Crofts and Parkin 1979).

Nursery grown transplants may be obtained in two forms, containerized or bare root stock. Containerized stock refers to young plants grown in a container that may range from a narrow tube to a milk carton to a 3.8 l (1 gal) plastic can. In general, the larger vessels hold older and larger plants, and such plants usually have better survival although they are more expensive. Container stock is typically grown in a greenhouse. Bare root stock is produced by digging up nursery plants and shaking the soil from the roots after they have been grown in beds for one to two years. Bare root plants are typically cultivated in outdoor beds and grow more slowly than containerized stock. They are planted in the same dormant season in which they were dug. Cold storage can maintain the bare root plants until the appropriate planting time. Early spring planting is best so that roots are established before top growth starts. A comparison of the two forms of nursery grown transplants is provided in Table 3.3-6.

Table 3.3-6. Comparison of Nursery Grown Planting Stock (Compiled from Institute for Land Rehabilitation 1979 and USDA Forest Service 1979.).

Container Grown	Bare Root
<p><u>Species</u> Some species are difficult to cultivate. In the northern Great Plains, recommended for evergreens by Orr (1977) and Bjugstad et al. (1980), and for general use by Jensen and Hodder (1979).</p>	<p>Most native shrubs and trees can be successfully grown and field planted. A few woody plants perform better in containers. Recommended for deciduous species by Orr (1977) and Bjugstad et al. (1980) and for general use by Crofts and Parkin (1979).</p>
<p><u>Availability</u> Available from Federal, State, and private nurseries during all seasons.</p>	<p>Available from Federal, State, and private nurseries. Not available at certain seasons, but may be stored in coolers for up to one year.</p>

Table 3.3-6 (concluded)

<u>Container Grown</u>	<u>Bare Root</u>
<p><u>Growth Time</u> Can be grown quickly by suppliers. In most cases should not be field planted when very young (i.e., less than about 10 weeks old) if frost is probable.</p>	<p>Usually field grown for one to two years.</p>
<p><u>Roots</u> Root system is better protected during planting. Nutrients and moisture are intact in containers. Roots may stagnate in the container after field planting (Stevens 1980).</p>	<p>Advisable for roots to be at least 15 to 20 cm (6 to 8 in) long, except on rocky sites where shorter lengths may be advantageous.</p>
<p><u>Preparation for Planting</u> Plants must be hardened before planting, i.e., exposed to cool temperatures and less watering, so that they resist cold, heat, and desiccation.</p>	<p>Dig up plants while dormant and plant in the same dormant season.</p>
<p><u>Ease of Handling</u> Heavier and bulkier. Many operations in the greenhouse can be mechanized.</p>	<p>Packages compactly in moist peat moss, but must be protected from wind and heat so that roots stay moist.</p>
<p><u>Maintenance before Planting</u> Difficult to maintain from delivery to field planting time because watering and daily care are needed.</p>	<p>Must be taken out of cold storage one day ahead of time to acclimate the stock. Roots must be kept moist.</p>
<p><u>Season to Plant</u> Spring best.</p>	<p>Early spring best so that new roots are established before top growth starts.</p>
<p><u>Cost</u> In northwest Colorado, from about 2 to 5 times more expensive per established plant (Crofts and Parkin 1979).</p>	<p>Less expensive.</p>

In the last decade, a number of plantings utilizing both containerized and bare root stock have been carried out in the West. Based on the results of eleven plantings in which the two stocks were directly compared, Crofts (1981) concluded that bare root nursery stock is clearly superior to containerized material. At best, containerized nursery stock is only half as cost-effective as bare root stock (using costs in Crofts and Parkin 1979).

In any particular case, there is substantial variability in the performance of bare root stock. Factors contributing to the unpredictability in performance include seed source and ecotype variability; nursery propagation techniques; handling, storage, and shipping; and destination storage, handling, and planting techniques (Orr 1977; Draves and Berg 1979; Institute for Land Rehabilitation 1979). In summary, bare root stock is less expensive and is easier to handle but takes more advance planning than container grown stock.

MAINTENANCE AND MANAGEMENT

Usually, supplemental watering after planting or other treatments are not necessary to ensure survival of most of the transplants. An initial watering immediately after planting is important for transplant survival. Protection from grazing and rodent damage is advisable (see Section 3.3.1.j, Pest Control, and Section 3.3.1.k, Grazing Management to Allow Vegetation Recovery). The degree of success depends on the particular seedling stock, its handling, the particular species, site characteristics, and the precipitation pattern and amount in the period immediately following the transplanting.

LABOR/MATERIALS

Three aspects of transplanting nursery grown stock will be discussed here: containers; holes to receive the stock; and costs.

Containers

Containers are important not only because they influence costs and techniques for transplanting, but also because the container size and shape can cause a deformed root system, which reduces plant survival and growth after outplanting. For instance, rectangular containers direct the roots to the corners and then downward. Or, a bottom on a container causes roots to become twisted and netted (Institute for Land Rehabilitation 1979). A study near Billings, MT demonstrated that tubelings with a polyethylene mesh sleeve can influence root growth, depending on the species rooting characteristics. Species with small diameter primary and secondary roots were not restricted in growth; whereas, species with enlarged primary and secondary roots were adversely affected by the mesh (Jensen and Hodder 1979).

A variety of containers have been used, including "tubelings" (Jensen and Hodder 1979), small plastic tubes, cardboard tubes, milk cartons, and one-gallon plastic and metal food cans (Gass 1980). Much useful information can be obtained from Tinus et al. (1974).

Planting Stock

Below are some considerations for planting nursery grown stock (Soil Conservation Service 1979):

- o Roots should be kept moist at all times before planting by covering with moist burlap or submersing in a container of water.
- o Roots should be spread out as close to natural position as possible during planting.
- o Holes should be deep enough to accommodate seedlings without bending roots.
- o Stock should be set the same depth as in the nursery or slightly deeper. In no case should a plant be set shallower than it was in the nursery.
- o Soil should be packed well around roots until seedling cannot be easily pulled from the ground. Care should be taken to eliminate all air pockets in the soil around the roots.
- o Stock should be watered at planting time.

Most planting is done by hand or with planting augers. The hand tools most commonly used are planting hoes and planting bars. Other specialized tools are used for container stock. Planting augers are portable powered tools that dig holes for bare root or containerized seedlings. More information on the use and availability of hand planting tools and planting augers are in Larson (1980). Larson's Revegetation Equipment Catalog also describes and presents capabilities and limitations for a tractor drawn implement for planting bare root seedlings. In addition, the U.S. Forest Service Equipment Development Center in Missoula (1980) is working on a dryland plug planter prototype for mechanized planting of containerized seedlings.

Costs

Crofts (1981) has calculated the comparative costs of obtaining a surviving plant from bare root and containerized stock (Table 3.3-7).

Table 3.3-7. Cost Required to Establish One Surviving Nursery Transplant.*

Method	Cost per Surviving Seedling by Year					
	1	2	3	4	5	6
Bare root	\$0.44	\$0.63	\$0.64	\$0.51	\$0.75	\$1.04
Containerized	\$0.88	\$1.62	\$1.34	\$1.17	\$5.00	\$6.11

*Based upon acquisition and planting cost of \$0.27 per bare root seedling and \$0.55 per containerized seedling from Crofts and Parkin (1979).

In short, bare root transplants are from 2.3 to 4.9 times more cost effective than containerized transplants (Crofts and Parkin 1979).

Sources of nursery grown stock are listed in Hinkle et al. (1981) or can be obtained from the State regulatory authority.

SOURCES OF INFORMATION

- o State Regulatory Authority
- o Office of Surface Mining
- o Nurseries: Federal, State, and private
- o State Agricultural Experiment Stations
- o State Forest Service
- o U.S. Soil Conservation Service
- o U.S. Forest Service Equipment Development Center

For addresses, see Appendix A.

References Cited:

- Bjugstad, A.; Yamamoto, T.; Uresk, D. Upland shrub establishment on coal and bentonite clay mine spoils. Proceedings of the Shrub Establishment Symposium; 1980 December 2-3; Laramie, WY; 1980.
- Crofts, K. The nonconcept of species diversity and woody plant density as revegetation success standards. Proceedings of the Northwest Colorado Land Reclamation Seminar II; 1981. Colorado State University Extension Service. (In press)
- Crofts, K.; Parkin, C. Methods of shrub and tree establishment on strip mined lands in Northwest Colorado. Paper presented before the symposium on surface coal mining and reclamation. Coal Conference Expo V; 1979 October 23-25; Louisville, KY. New York: McGraw-Hill; 1979.
- Draves, R.; Berg, W. Establishment of native shrubs on disturbed lands in the mountain shrub vegetation type. Ft. Collins, CO: Colorado State University Department of Agronomy; 1979.
- Gass, R. Options for transplanting. Brittain, R.; Myrman, M., eds. Vegetative reclamation of mine wastes and tailings in the Southwest; 1980 April 23-25; Tucson, AZ. Mine Reclamation Center. Arizona Mining and Mineral Resources Research Institute; 1980.
- Hinkle, C. R.; Ambrose, R. E.; Wenzel, C. R. A handbook for meeting fish and wildlife information needs to surface mine coal. OSM Region 5, Washington, D.C.; USFWS FWS/OBS-79/48.3.5; 1981.
- Institute for Land Rehabilitation. Selecting, propagation and field establishment of native plant species on disturbed arid lands. Utah Agricultural Experiment Station Bulletin 500: Logan, UT; 1979. 49 p.

Jensen, I.; Hodder, R. Tubelings, condensation traps, mature tree transplanting and root sprigging techniques for tree and shrub establishment in semiarid areas. Montana Agricultural Experiment Station Research Report 141: Missoula, MT; 1979. 105 p.

Larson, J. Revegetation equipment catalog. USDA Forest Service Equipment Development Center, Missoula, MT; 1980.

Orr, H. K. Reestablishment of wooded waterways and associated upland shrub communities in surface coal mining areas of the northwestern Great Plains. Fifth symposium surface mining and reclamation NCA/BCR coal conference and expo IV; October 18-20; Louisville, KY; 1977.

Soil Conservation Service. Standards and specifications: tree planting. Technical Guide, Section IV, Code 612; 1979.

Stevens, R. Shrubs can be transplanted successfully with a tree transplanter. Russell, T. V., chairman. 34th Annual Report. Vegetative Rehabilitation and Equipment Workshop; 1980 February 10-11; San Diego, CA. USDA Forest Service, Washington, D.C. 20013; 1980.

Tinus, R. W.; Stein, W. I.; Balmer, W. E., editors. Proceedings of the North American Containerized Forest Tree Seedling Symposium. Great Plains Agricultural Council Publication 68; 1974. 458 p.

U.S. Forest Service. User guide to vegetation. Mining and Reclamation in the West. USDA Forest Service Gen. Tech. Rep. INT-64: Intermountain For. and Range Exp. St., Ogden, UT; 1979. 85 p.

U.S. Forest Service. Dryland plug planter. Missoula, MT. USDA Forest Service Equipment Development Center; 1980.

Additional References:

Hartman, H. T.; Kester, D. E. Plant propagation. 3rd ed. Englewood Cliffs, NJ: Prentice Hall, Inc.; 1975.

f. Cover crops/preparatory crops.

PURPOSE

Cover crops and preparatory crops are species planted to act as temporary stabilizers of the site until permanent vegetation can be established. Even though their functions are similar, there are important differences in the two crop systems. Cover crops (sometimes called companion or nurse crops) are annual crops, such as peas, barley, sorghum, rye, sudan-grass, or oats, that are seeded with perennial species to modify microenvironmental conditions until the perennial species can become established. Preparatory crops are seeded before the perennial forage; the crop is mowed, and the perennial species are seeded directly into the stubble (U.S. Forest Service 1979). These crops can be used to stabilize the site as well as provide a cleaner (weed-free) seedbed.

DEVELOPMENT

Cover crops are not recommended for semiarid regions where moisture shortages are likely during the establishment period, or on soils of low fertility (U.S. Forest Service 1979). The cover crop will compete with perennial grasses for nutrients, light, and especially water, resulting in poor establishment of the perennial species. If irrigated, cover crops will not compete as severely with the desired permanent vegetation.

Preparatory crops have been more successful in the West. Advantages of using a preparatory crop are that it may:

- o protect topsoil until a permanent species can be established;
- o control wind and water erosion;
- o reduce evaporation from around seeds and establishing plants;
- o smother out germinating weeds;
- o reduce or prevent a new crop of weeds; and
- o provide food or cover for small mammals, birds, and waterfowl.

In the Powder River-Fort Union Coal Region, many mines plant barley or wheat in the spring as preparatory crops. At Peabody Coal's Seneca Mine, barley or wheat are cover cropped in the fall if the reclaimed area is ready for seeding at that time. Since each site has different environmental influences, the decision to use a nurse or preparatory crop depends on rainfall, steepness of slope, and the timing of revegetation. The local Soil Conservation Service office can give advice on what species to use and the best timing according to local conditions.

Schuman et al. (1980) compared the effectiveness of crimped straw or hay residue used as a mulch with the use of a small grain planted in the spring and a grass mixture fall-seeded into the stubble. The stubble mulch or preparatory crop proved to be statistically as good as the straw mulch for establishment of perennial grasses, showed slight benefit in effects on soil moisture and temperature, and significantly increased the infiltration. The preparatory crop method gave about a 10% greater population of the native grass seeded.

In selecting species for use as preparatory crops, consideration should be given to quickness of germination, growth rate, water and temperature requirements, canopy cover produced, herbage and root production, and seed availability and cost.

MAINTENANCE AND MANAGEMENT

Preparatory crops should be mowed before they produce seed to prevent competition with the perennial species to be established.

LABOR/MATERIALS

Use of preparatory crops will increase the labor and other costs involved in reclamation but, in the long run, it may also increase the survival of the perennial species, so that seeding would not have to be repeated.

Items listed in Table 3.3-8 are adapted from Schuman et al. (1980), who compared the cost of preparatory crop treatments with crimped straw mulch at two locations in Wyoming.

Table 3.3-8. Comparative Cost of Preparatory Crops and Crimped Straw Mulch.

<u>Location</u>	<u>Cost of Crimped Straw (5 MT/ha)</u>	<u>Cost of Planted Stubble</u>
Northern Energy Resources Co., Glenrock Coal Co., WY	\$803/ha (\$326/acre)	\$ 40/ha (millet) (\$ 16/acre)
Pathfinder Mines Corp., Shirley Basin, WY	\$618/ha (\$251/acre)	\$148/ha (barley) (\$ 60/acre)

SOURCES OF INFORMATION

- o State Regulatory Authority
- o Office of Surface Mining
- o State Agricultural Experiment Stations
- o County Agricultural Extension Agents
- o University Agriculture Departments
- o Seed Suppliers

For addresses, see Appendix A.

References Cited:

Schuman, G. E.; Taylor, E. M., Jr.; Rauzi, F.; Howard, G. S. Standing stubble on mined lands. *J. of Soil and Water Cons.* 35(1):25-27; 1980.

U.S. Forest Service. A user guide to vegetation. USDA For. Serv. Gen. Tech. Rep. INT-64; Intermt. For. and Range Exp. Stn.: Ogden, UT; 1979.

g. Water conservation.

PURPOSE

In the arid West, conserving water for use by vegetation is extremely important. Increasing the amount of water stored in the soil for use by plants during the growing season may allow establishment and growth of seeded vegetation even in years of subnormal precipitation. Snow fences, windbreaks, and rock and brush piles allow a buildup of snow in specified areas which then is available to the soil as it melts. Surface manipulation, such as gouging or chiseling, also may restrict wind and water erosion, as well as conserve rainfall and provide suitable sites for vegetation establishment.

DEVELOPMENT

Snow Fences

Much of the precipitation in the Powder River-Fort Union Coal Region occurs as snow and may be lost through wind and sublimation. Usually, snow fences are used to keep an area free of deep snow, but the same type of barrier can be used to increase snow depth and, thus, the amount of available water to newly planted vegetation.

General topography limits the effectiveness of snow fences and not all locations are suitable. In a study near Kemmerer, WY (May and Lang 1971), it was determined that snow fences were effective only when placed on the leeward side of large, open level areas and at right angles to the prevailing wind.

Additional benefits of snow fences include the accumulation of natural mulch and windblown seed, and versatility as either a permanent or temporary treatment that can eventually be replaced by "living" snow fences (see Section 3.3.3.c, Creating Wind and Snowbreaks for Winter Wildlife Protection). The most effective fence design includes 50% porosity (open area between the slats), a bottom-gap of one-tenth the fence height, and the use of horizontal slats having widths less than 20.3 cm (8 in). Tabler (1980) studied drifts which accumulated behind snow fences of both the horizontal and vertical slat varieties and found the vertical slat drifts to contain 26% less water-equivalent volume. A fence 3.7 m (12 ft) high would be very useful for drift prevention, but snow fences for protecting transplanted shrubs and augmenting soil water should be shorter, or more porous (U.S. Forest Service 1979). Fences that are 0.6 m (2 ft) high, spaced 18.6 m (60 ft) apart, will provide a relatively uniform snow cover on level terrain. Fencing that is 1.2 m (4 ft) high, having about 75% porosity, will also result in a sufficiently shallow, uniform deposit on level terrain. Spacing should be about $30 \times H$ (height of the fence), which is the maximum length of the drift behind a fence.

To determine the volume of water stored behind a fence, a single equation - $10 \times H^2$ per linear foot of fence can be used (U.S. Forest Service 1980). For engineering drawings for effective snow fences, see Tabler (1975).

Tabler has conducted extensive research on snow fences at the Rocky Mountain Forest and Range Experiment Station in Laramie, WY. Contact the Experiment Station for more information on snow fence construction for increased water supply (see Appendix A).

Surface Manipulation

Compaction of the spoils by heavy equipment used in shaping and topsoiling processes can reduce infiltration and storage of precipitation. Consequently, oil, seed, and fertilizer could be washed from slopes before the stabilizing vegetation becomes established. Scarification before topsoiling or freeze-thaw periods can offset the compaction problem. In addition, mulching (see Section 3.3.1.h) can minimize the loss of topsoil, seed, and fertilizer.

Surface manipulation is the modification of the surface lands into configurations which reduce the rate of runoff by intercepting, storing, and encouraging infiltration. Four commonly used methods are gouging, deep chiseling, dozer basins, and land imprinters. Gouging is accomplished with a specially constructed machine having hydraulically operated 61.3 cm (25 in) scoops that are raised and lowered while being drawn by a tractor, creating elongated basins 30 to 40 cm (14 to 16 in) wide, 1.0 to 1.3 m (3 to 4 ft) long, and 15 to 20 cm (6 to 8 in) deep (Figure 3.3-3). Gouging is most effective on the slope contour.

Dozer basins are created by dropping the bulldozer blade at an angle to form elongated basins 3 to 5 m (10 to 16 ft) long and 0.6 to 1.0 m (2 to 3 ft) deep. Basins are constructed in parallel rows with about 6.2 m (20 ft) between rows, depending on the gradient of the slope, and are used for stabilization of steeper slopes (Sindelar et al. 1974).

Deep chiseling can be done with a modified Graham-Hoeme plow with 12 chisels to break up compacted surfaces to a depth of 20 to 30 cm (8 to 12 in). Improved infiltration rates are a major feature of deep chiseling.

The land imprinter creates a series of geometric patterns on the ground surface to control erosion and increase infiltration. The imprinter is essentially a towed chopper with two interchangeable drums mounted on a common axle, which crushes and chops brush; mixes and imbeds surface debris or seed; and forms stable, complex impressions on the ground. The resulting closed V-shaped furrows can collect up to 5 cm (2 in) of rainfall and displace concentrated runoff (Larson 1980).

The advantages and disadvantages of these surface manipulation techniques are presented in Table 3.3-9.

In a study done on surface manipulation that compared gouging, chiseling, and dozer basins at the Western Energy Company Rosebud Mine at Colstrip, MT, Sindelar et al. 1974, found that the most efficient treatment in terms of soil moisture storage in the upper 1.3 m (4 ft) of soil was gouging. Gouging greatly reduced the number of moisture stress days for vegetation and resulted in slightly increased seedling survival.



Figure 3.3-3. Tractor-drawn modified Hodder Gouger (Photo courtesy of U.S. Forest Service Equipment Development Center, Missoula, MT).

Table 3.3-9. Advantages and Disadvantages of Surface Manipulation Techniques.

Techniques	Advantages	Disadvantages
Gouging	<p>Most efficient in storing soil moisture in 1.3 m (4 ft) of soil</p> <p>Increases infiltration</p> <p>Improves erosion control</p>	<p>Pitted hillside produced</p> <p>Designed for slopes of 20% or less</p>
Dozer Basins	<p>Effective on hillsides</p> <p>High plant densities found in dozer basins</p> <p>Increases infiltration</p> <p>Improves erosion control</p>	<p>Not suited for level ground</p> <p>Sparse vegetation survival surrounding basins</p> <p>Deeply pitted hillsides produced</p> <p>Clay soils inhibit infiltration; water may evaporate without benefiting plants</p>
Deep Chiseling	<p>Good seedbed produced</p> <p>Can be used on level ground or hillsides</p> <p>Well suited to rocky land</p>	<p>Low ground clearance prevents effective brush control</p> <p>No improved soil moisture conditions</p>
Land Imprinter	<p>Improves erosion control</p> <p>Increases infiltration</p> <p>Can operate on rough, rocky or brush-covered terrain on slopes up to 45%</p>	<p>Cannot treat dense stands of sprouting brush</p>

Dozer basins did not appear to store significantly more moisture in the upper 1.2 m (4 ft) of soil than did chiseling. Although vegetation growing within dozer basins was profuse and resulted in high plant densities, areas between basins supported only sparse vegetation. While chiseling did not provide good soil moisture conditions and improved erosion control, it did produce a good seedbed which resulted in a satisfactory vegetation cover.

The benefits of erosion control and increased moisture storage must be weighed against the drawbacks of producing a pitted hillside that might prove dangerous to large herbivores, such as deer and pronghorn, as well as cattle. The land imprinter operates satisfactorily on rough, rocky, or brush-covered terrain and on most soil conditions. It can treat slopes up to 45% but cannot treat dense stands of sprouting brush.

MAINTENANCE AND MANAGEMENT

Snow fences require very little maintenance beyond occasional repair or replacement of weather damaged portions. Maintenance for surface manipulation would only apply to the equipment used. As the vegetation matures, no management should be necessary as the natural successional patterns take over.

LABOR/MATERIALS

Standard 1.2 m (4 ft) high snow fence is approximately \$3.75 to \$4 per running 0.3 m (foot) including fencing, T-bars, wire, and installation.

Surface manipulation devices can all be attached to crawler or standard tractors which most mines would use for other operations. The gouger implement costs \$12,000 and the land imprinter is slightly over \$11,000. A chisel plow can be obtained from most farm implement dealers for approximately \$1,000. Dozer basins are formed by standard dozer blades. A "D9 Cat" can bulldoze out a dozen basins over a 4- to 6-ha (10- to 15-acre) area in about 8 hours at a cost of around \$900 for the operation of the machine and the driver's labor. A basin blade that can be mounted on the rear of a crawler tractor to scoop out large basins would cost approximately \$9,000 to \$10,000 using the specifications of the USDA Forest Service Equipment Development Center in Missoula, MT.

SOURCES OF INFORMATION

- | | | |
|-----------------------|---|---|
| General: | o | State Regulatory Authority |
| | o | Office of Surface Mining |
| Snow fences: | o | Wyoming Department of Highways |
| | o | Fencing suppliers |
| | o | State Agricultural Research Stations |
| | o | Rocky Mountain Forest and Range Experiment Station, Laramie, WY |
| Surface manipulation: | o | Reclamation Equipment manufacturers |
| | o | State Agricultural Research Stations |

For addresses, see Appendix A.

References Cited:

- Larson, J. E. Revegetation equipment catalog. U.S. Forest Service Equipment Development Center, Missoula, MT; 1980.
- May, M.; Lang, R. Reclamation of strip mine spoil banks in Wyoming. Research Journal 51, Ag. Exp. Sta., Univ. of Wyoming, Laramie; 1971.
- Sindelar, B. W.; Atkinson, R.; Majerus, M.; Proctor, K. Surface mined land reclamation research at Colstrip, Montana. Montana Ag. Exp. Sta. Res. Report 69. Montana State Univ., Bozeman; 1974.
- Tabler, Ronald D. Estimating the transport and evaporation of blowing snow. Snow manage. on Great Plains symp. 1975 July, Bismarck, ND. Proc. Great Plains Agric. Counc. Publ. 73; 1975.
- Tabler, R. D. Geometry and density of drifts formed by snow fences. J. Glaciol. 26:405-419. 1980.
- U.S. Forest Service. User guide to vegetation. Gen. Tech. Report INT-64: Intermt. For. and Range Exp. Stn., Ogden, UT; 1979. 85 p.
- U.S. Forest Service. User guide to hydrology. Gen. Tech. Report INT-74: Intermt. For. and Range Exp. Stn., Ogden, UT; 1980. 64 p.

h. Mulching.

PURPOSE

A mulch is defined as any nonliving material placed or left on or near the soil surface for the purpose of protecting it from erosion or protecting plants from heat, cold, or drought. Mulches are effective in modifying environmental factors to improve soil properties, soil moisture availability, and temperature conditions. Stabilizing an area can be done by establishing plant growth as quickly as possible. Mulching can be used to protect the site until plants become established and will often shorten the time for adequate plant growth. Mulching is a reclamation practice required by most regulatory authorities.

DEVELOPMENT

Both organic and inorganic mulches can be used and include asphalt mulches, jute or excelsior netting, straw, sawdust, and chemical mulches; however, organic mulches have a relatively short effect, decomposing within about a year. In addition, organic mulches with a high carbon to nitrogen ratio (>25:1) can potentially cause nitrogen deficiencies because the microorganisms decomposing the organic matter are more efficient in using any inorganic nitrogen than are the plants. As a result, these microorganisms decrease the availability of inorganic nitrogen and leave a deficiency for a short time. Included among mulches that have a high carbon to nitrogen ratio are straw and wood waste.

Another problem associated with mulches is germination inhibition. Mulches high in nitrogen could produce ammonium concentrations that could be toxic to germinating seedlings. Light colored mulches can lower soil temperatures and, at certain times, this might have an inhibiting effect on plant growth.

Some mulches may contain weed seeds that could compete with the desired seedlings. Insects, fungi, and diseases can also be transported to the site via mulch. Rodents can be attracted to a mulch and then eat seeds or seedlings.

For mulching, the modified StakProcessor uses a flail device to distribute straw mulch from 680 kg (1,500 lb) round bales. The StakProcessor is not suited for steep terrain and the mulch should be incorporated into the ground in some fashion. Power mulchers blow dry fiber mulch, mostly straw and hay, onto treatment areas. These mulchers can cover inaccessible areas with self-attaching mulches blown from a nearby bench or road. Another blower, the Estes spreader, can blow up or down a slope but is limited to accessible areas.

The advantages and disadvantages of commonly used mulches are listed in Table 3.3-10 (U.S. Forest Service 1979). Factors to be considered when choosing a mulch are cost, type of vegetation to be planted, and characteristics of the site.

Table 3.3-10. Advantages and Disadvantages of Different Types of Mulches (from U.S. Forest Service 1979).

Type of Mulch	Advantages	Disadvantages	Comments
Hydraulic mulching	<p>Typical green color allows operator to get uniform distribution</p> <p>Hydromulching and hydroseeding can be done at the same time</p>	<p>Labor and maintenance costs high</p> <p>Of little value unless it adheres to the soil surface and remains intact during rainstorms, wind</p> <p>Hydromulch with fiber improves germination, not production</p> <p>When hydromulch and hydroseeding are done together, seeds may not have adequate soil contact</p>	<p>Application rate of 682 kg/0.4 ha (1,500 lb/acre) adequate for most situations; may need more for steep slopes</p> <p>May need to add N to hydro-mulch to compensate for C:N ratio of mulch chosen</p>
Fabric or mats: jute, excelsior, woven, paper, plastics, nets	<p>Especially useful on steep slopes</p> <p>Nets good in high wind areas</p>	<p>Expensive: 4-5 times more than tacked straw</p> <p>High labor input for anchoring</p> <p>Not effective on rough surfaces or rocky areas</p> <p>Erosion from beneath may be a problem</p>	<p>Used only on limited critical areas because of cost</p>
Manure and sewage sludge	<p>Can protect soil surface and adds nutrients, such as N, P, K, S</p>	<p>When used alone, it desiccates and can lose much of the N through volatilization of ammonia</p>	<p>Needs 4.5 to 13.6 MT/0.4 ha (5 to 15 tons/acre) in order to protect soil</p>

Table 3.3-10 (continued)

Type of Mulch	Advantages	Disadvantages	Comments
Asphalt	Rapid-curing asphalt keeps straw and other materials in place Slow-curing asphalt allows for growth of seedlings before it cures Coats surface, remains intact 4 to 10 weeks More porous than asphalt Insoluble in water Resistant to weathering Resistant to erosion	Nonporous, causes surface water to run off Some plants react negatively to it	4.542 ϵ /0.4 ha (1,200/gal/acre) an average application Typically, heated and spread by spraying Apply from top of slope down 2,271 ϵ /0.4 ha (600 gal/acre) good against wind erosion Often considered superior to asphalt
Resin emulsion in water	Resistant to erosion	Limits water penetration Some studies indicate it is less effective than other mulches	
Latex emulsion	Generally most economical Usually satisfactory under many circumstances	Weed seeds usually present; even hay seeds may be considered a weed on a particular site Straw may "wick-out" moisture from soils in very dry conditions, resulting in poor germination and seedling establishment	Anchor mulch, especially on slopes, by crimping or using plastic meshes, jute, chemical tackifiers Uniform application important Generally, 0.91 MT/0.4 ha (1 ton/acre) adequate
Crop residues; Straw or hay			

Table 3.3-10 (concluded)

Type of Mulch	Advantages	Disadvantages	Comments
Native grasses; prairie hay	Adds desirable native species seeds to area and mulches at same time	May harvest weeds along with native species	
Wood residues; sawdust, wood-chips, bark, shavings	Protects surface Adds organic matter No weed seeds More fire resistant than straw Long lasting Easy to apply	Shavings and sawdust blow Nitrogen deficiency Packing may occur resulting in less aeration May float on running water May prevent precipitation from reaching soil	Chips: 1.8 MT/0.4 ha (2 tons/acre) usually adequate; chip size, 13 to 0.5 mm (0.5 to 1/50 in)
Plastic film	Excellent vapor barrier Good weed control	Labor intensive High cost	Information on temperature effect varies Color is important because of reflection, absorption
Fiber tackifiers and soil binders	SBR Styrenebutadiene and SS Super Slurper have been found to be very absorbent and thus help provide water	Quite expensive Must be applied correctly for maximum effectiveness In high wind areas, it can solidify, break into pieces and blow away	Typically added into water carriers; can also be added with seed slurries 227 to 455 kg (500 to 1,000 lb) of solids/0.4 ha (1 acre) usually sufficient, dilution rates of 5:1 to 7:1 optimum
Rocks, gravel, pebbles	Effective at specific sites Are permanent--do not disintegrate	Smaller than 2.1 mm (1/12 in) diameter poor for wind erosion	Must nearly cover entire ground surface 2.5 to 5 cm (1 to 2 in) thick to be effective control (123 MT 0135 tonso/0.4 ha (1 acre) = about 2.5 cm (in) depth)

MAINTENANCE AND MANAGEMENT

Mulching is a one-time application and therefore requires no further maintenance. As the vegetation matures, no management should be necessary as the natural successional patterns take over.

LABOR/MATERIALS

Mulching equipment costs are extremely variable. The StakProcessor costs slightly over \$7,000 and can be attached to a tractor. Finn power mulchers are towed and vary from \$8,000 for the smaller models to \$17,300 (\$20,300 for diesel) for the larger models (freight charges included). The Estes Blower Spreader is mounted on a truck and costs \$20,540 for a 3-m (10-ft) hopper and \$22,185 for a 4.9-m (16-ft) hopper.

Material and application costs will vary with the type of mulch used. At the Kemmerer Coal Fields, material and labor costs (excluding seed costs and adjusted to approximate 1982 dollars) of comparative treatments ranged from \$550/0.4 ha (1 acre) for straw mulch held in place by a wire netting, to \$2,750/0.4 ha (1 acre) for jute netting, to \$3,200/0.4 ha (1 acre) for jute netting underlain with straw (Jacoby 1969).

SOURCES OF INFORMATION

- o State Regulatory Authority
- o Office of Surface Mining
- o Soil Conservation Service
- o County Agricultural Extension Agents
- o State Agricultural Research Stations
- o University Agriculture Departments

For addresses, see Appendix A.

References Cited:

- Jacoby, P. W. Revegetation treatments for stand establishment on coal spoil banks. *J. Range Manage.* 22:94-97; 1969.
- U.S. Forest Service. User guide to vegetation. Gen. Tech. Report INT-64: Intermt. For. and Range Exp. Stn., Ogden, UT; 1979. 85 p.

Additional References:

- Larson, J. E. Revegetation equipment catalog. U.S. Forest Service Equipment Development Center, Missoula, MT; 1980.
- U.S. Forest Service. User guide to hydrology. Gen. Tech. Report INT-74: Intermt. For. and Range Exp. Stn., Ogden, UT; 1980. 64 p.

i. Irrigation.

PURPOSE

The arid and semiarid conditions in the Powder River-Fort Union Coal Region are characterized by high intensity seasonal storms, long periods of drought, and unpredictable precipitation patterns. Although native vegetation survives under these conditions, the germination of many species is limited to the few years when soil moisture is sufficient (Sherman and Sullivan 1980). During the intervening years, the result can be a monoculture of vegetation best suited to prevailing moisture conditions. As a tool for use during the germination and initial growth stage, irrigation can be very useful for improving reclamation success.

DEVELOPMENT

Research at the Northern Great Plains Research Center, Mandan, ND has shown that the use of irrigation to supplement natural precipitation can help insure rapid and successful perennial plant establishment, especially when natural precipitation is low (Ries 1980). Irrigation is generally used for the first year or two. Once vegetation is established, plants require less water and the irrigation system is usually removed. Water suitable for irrigation is available in many of the mine pits or from wells that furnish water for various mining activities (May 1975). At the Jim Bridger Mine in Rock Springs, WY, irrigation is used to supplement the annual 20.32 cm (8 in) precipitation, speed up the process of seedling germination, and aid survival.

The two most frequently used irrigation systems for reclaiming mine sites are drip and sprinkler irrigation. The advantages and disadvantages of these two systems are outlined in Table 3.3-11.

Drip (trickle) irrigation is the process by which water is slowly delivered to a plant (approximately 1.9 to 7.6 μ /minute [0.5 to 2 gpm]) from a point source called an emitter (Sherman and Sullivan 1980). The application rate should not exceed the soil's intake rate. Drip irrigation is usually not a full coverage system; perhaps as little as 25 to 30% of the total field is wetted.

The laterals which supply water to the emitters are usually polyethylene hose of diameters varying between 1.37 and 1.47 cm (0.50 and 0.58 in) diameter. Several laterals may be joined by a manifold and connected to a water supply line through a common valve. This practice allows repairs to be made without shutting the entire system down. An extensive filtration system may be required for the drip system, depending upon water quality. Water must be as clean as tap water to prevent clogging problems. Generally, the lower the water quality, the greater the filtration system cost, complexity, and labor requirement.

Fertilizer which is water soluble may be applied through drip systems. Precautions should be taken so that precipitates do not form, which tend to coat the pipeline and clog the emitters.

Table 3.3-11. Advantages and disadvantages of drip and sprinkler irrigation systems (from USDA Forest Service 1979; Bengson 1980).

Type of Irrigation System	Advantages	Disadvantages	Comments
Drip irrigation	<p>Uses 1/3 less water than sprinkler systems</p> <p>Evaporation is minimal</p> <p>Amounts of water can be placed directly where wanted</p> <p>Especially wanted on steep slopes, under power lines (because it is safer), between buildings, on critical areas</p> <p>Moves salts away from plant roots</p> <p>Well suited for woody vegetation</p>	<p>If water contains high sediment level, it will clog the lines, unless well filtered</p> <p>If water is high in salt, deposits can build up around the emitter openings</p> <p>Requires more maintenance than sprinklers because the filtering system must be periodically inspected</p> <p>Labor intensive</p> <p>Less portable</p> <p>Shorter life span than sprinkler</p> <p>More easily damaged; e.g., rodents can chew holes in hoses</p> <p>More evaporation will occur</p>	<p>Also called trickle irrigation</p> <p>Plant densities will be less; this can be a disadvantage, but not always</p> <p>Adequate filtering system crucial</p> <p>Quality of water (sediment, salinity) a factor</p> <p>Three types of emitters; spitter (puts out a spray); single (puts small amount in local place); and bi-wall (plastic tubing with pin-prick opening to emit water)</p>
Sprinkler	<p>Less filtering needed</p>	<p>High plant densities possible</p>	

Table 3.3-11 (concluded)

Type of Irrigation System	Advantages	Disadvantages	Comments
Sprinkler (continued)	Less expensive than drip	Need larger water supply	
	Less labor intensive	Frequency of application higher than drip	
	Longer life	Can cause erosion problems	
	Easier to move, more flexible		
	Gentle on friable or easily crusted soils		
	Adaptable to most fields and terrains		

Drip systems usually operate at an emitter pressure of approximately 10 to 40 psi. An appropriate pumping unit should be selected to supply an adequate quantity of water at this pressure.

At the Westmoreland Absaloka Mine near Harden, MT, a drip irrigation system has been installed to improve the survival of ponderosa pine seedlings. Because the system is so new, an evaluation of the effectiveness of the system has not been made.

After a survey of the general irrigation methods of surface, subsurface, drip, and sprinkler, Sherman and Sullivan (1980) determined that, in the West, sprinkler irrigation in the form of above ground, portable, solid set was the most feasible and practical approach where rangeland or wildlife habitat is considered to be the final land use.

The solid set sprinkler fits the needs of native vegetation because it can supply a steady, moist environment in a timely fashion, without disturbing the seed or the soil around it. Solid set is a network of pipes and sprinklers typically spaced 10 or 12 m (30 or 40 ft) apart. An entire field can be irrigated by opening and closing valves, either automatically or manually.

The hardware used in solid set systems consists of five basic components:

- o Sprinklers
- o Laterals
- o Manifolds
- o Water Supply Lines
- o Water Source

Impact or rotary sprinklers, which typically emit 3.8 to 75.7 l (1 to 20 gal)/min at pressures of 30 to 80 psi, are generally used for irrigation. Risers connect the sprinklers to the water supply line, or lateral. Risers are required to provide proper clearance between the sprinkler and the crop and may benefit uniformity of application when windy conditions prevail. The assembly of sprinklers, laterals, risers, and the automatic or manual valves which direct water flow are illustrated in Figure 3.3-4.

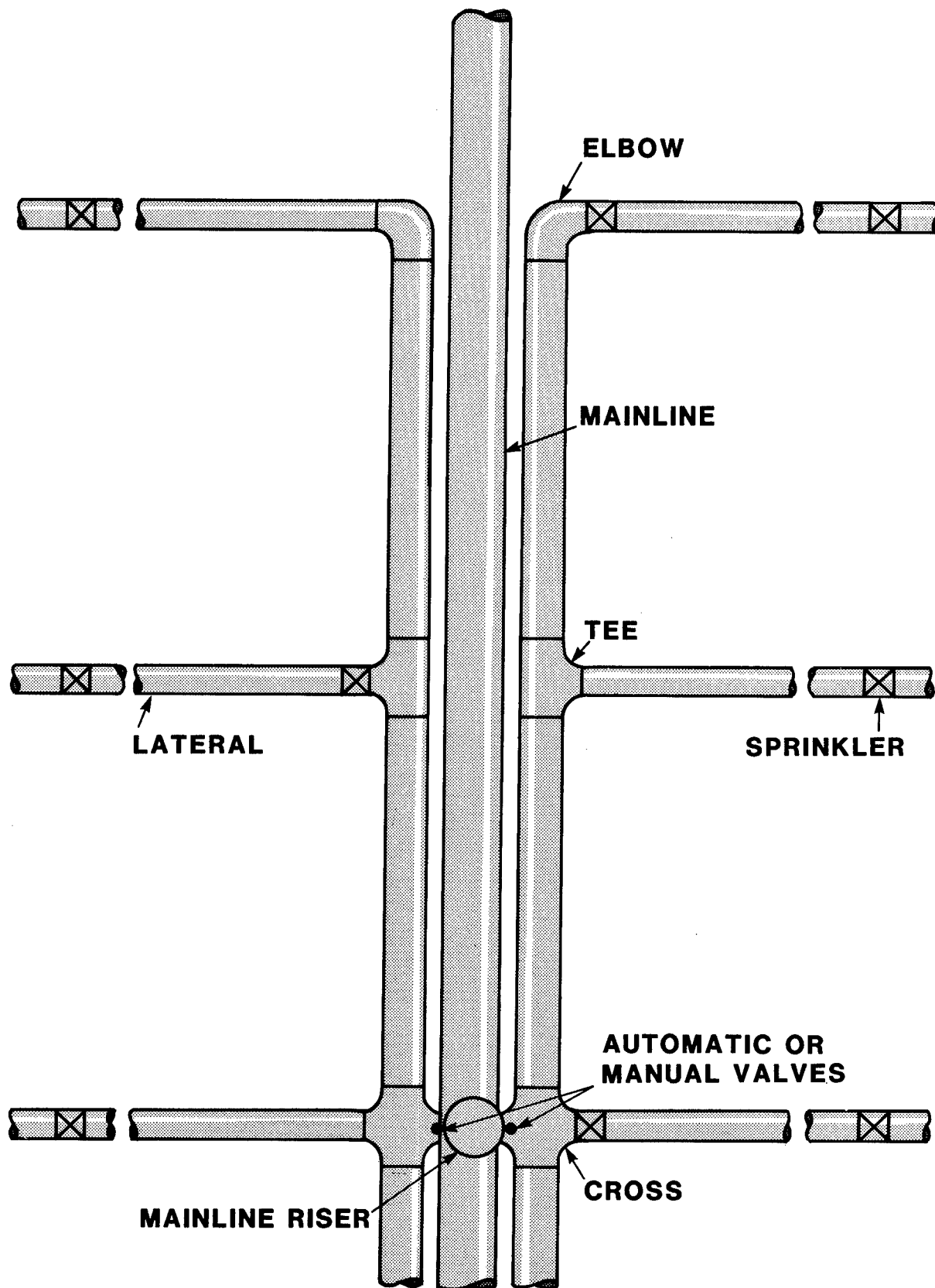

Figure 3.3-4. Manifold detail.

Principal advantages of solid set are the ability to irrigate and fertilize the entire field, regardless of configuration (see Figures 3.3-5 and 3.3-6), at low application rates and yet have flexibility in irrigation duration and frequencies. Reclamation irrigation is supplemental and temporary in concept and should be used on a given field for only one or two seasons. The vegetation should then be capable of surviving on its own, and the system can be moved to new areas as mining and reclamation progresses.

Water resources are usually very limited in the Powder River-Fort Union Coal Region. Often a 152.4 to 304.8 m (500 to 1,000 ft) well will yield no more than 37.9 to 75.7 ℓ /min (10 to 20 gallons/min) (Sherman and Sullivan 1980). The limited surface water resources are often fully allocated to downstream agricultural users. Sediment ponds and pit water are potential sources but use is dependent upon quality. Ries (1980) researched the use of supplemental water, including the use of poor quality water, for the establishment of perennial vegetation on strip-mined lands. Initial results indicated that stands irrigated with either good or poor quality water have been found equal. Where natural precipitation plus poor quality water were used for two seasons, the stands of seeded species had a higher productivity than stands established with only natural precipitation. Increases in salt, soluble sodium, and SAR were moderate where poor quality water (EC of 3.0 to 4.0 mmhos/cm²) was used.

The use of irrigation is dependent upon the availability and cost of water and the anticipated success of establishing plant growth without supplemental water.



Figure 3.3-5. Solid set irrigation system on mined site.

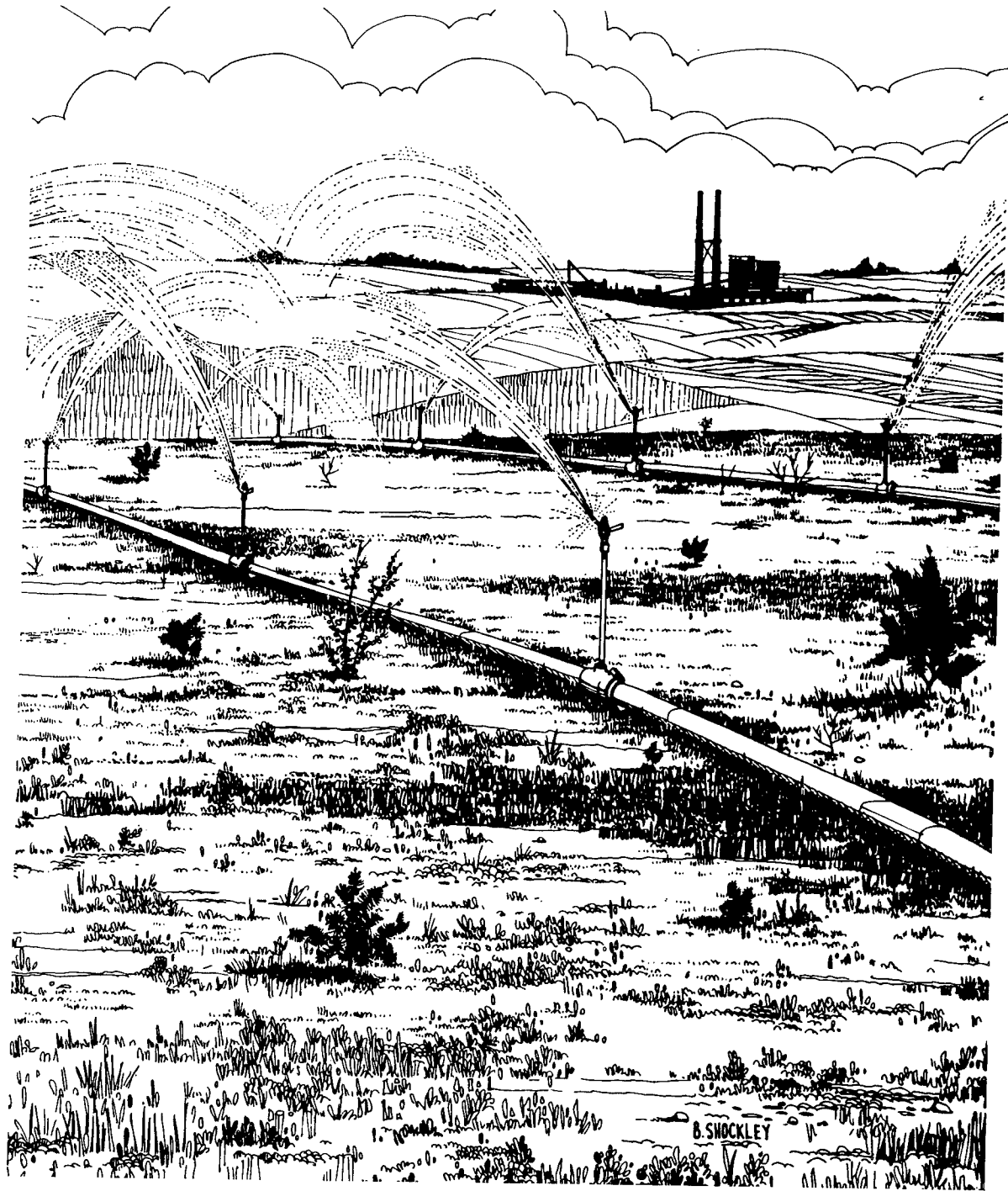

Figure 3.3-6. Artist's representation of a solid set irrigation system operating on a reclaimed mine site.

MAINTENANCE AND MANAGEMENT

Irrigation systems require a great deal of maintenance. The drip system often becomes clogged by sediment unless well filtered and salt deposits can build up around the emitter openings. The filtration system and the laterals must be periodically flushed to prevent buildup of fouling material. Corrosion of pipelines may occur where the water or soil quality are poor. If the system is automated, management is lower, except for increases in set-up time.

LABOR/MATERIALS

Both drip and solid-set systems have a high equipment cost. The Bridger Coal Company in Rock Springs, WY, is using a solid-set sprinkler system on the Jim Bridger Mine. The set-up cost was \$1 million to irrigate 97 ha (240 acres) at one time. Drip system costs are generally higher on a per-acre basis than sprinkler systems; comparative cost data were unavailable.

The labor required to maintain and operate a drip system must be available throughout the season. Since, in most cases, emitters operate silently, they must be checked frequently by inspecting each device. The filtration system must also be flushed regularly and requires skilled labor. The use of automatic valves and a controller allows sprinkler systems to operate with a minimal labor requirement.

SOURCES OF INFORMATION

- o State Regulatory Authority
- o Office of Surface Mining
- o U.S. Soil Conservation Service
- o County Agricultural Extension Agents
- o State Agricultural Research Stations
- o Irrigation Systems Manufacturers
- o USDA Northern Great Plains Research Center

For addresses, see Appendix A.

References Cited:

- Bengson, S. A. Irrigation techniques for mine revegetation in the arid Southwest. Brittain, R. G.; Myhrman, M. A. eds. Vegetative reclamation of mine wastes and tailings in the Southwest; 1980 April 23-25; Tucson, AZ. Mine Reclamation Center. Arizona Mining and Mineral Resources Research Institute; 1980.
- May, M. Moisture relationships and treatments in revegetating strip mines in the arid West. J. Range Manage. 28:334-335; 1975.
- Ries, R. E. Supplemental water for the establishment of perennial vegetation on strip-mined lands. North Dakota Farm Research 37(6):21-23; 1980.

Sherman, R. M.; Kinkead, J. A.; Campbell, G. J.; Alder, G. M. Irrigation for reclamation of strip mined lands (draft). Prepared for USDI Bureau of Mines; 1980.

U.S. Forest Service. User guide to vegetation. U.S. For. Serv. Gen. Tech. Report INT-64; Intermt. For. and Range Exp. Stn., Ogden, UT 84401; 1979. 85 p.

Additional References:

Hagen, R. M.; Haise, H. R.; Edminster, T. W., editors. Irrigation of agricultural lands. Agronomy No. 11. Madison, WI: American Society of Agronomy; 1967.

Israelson, O. W.; Hansen, V. E. Irrigation principles and practices. New York, NY: John Wiley and Sons, Inc.; 1962.

Merriam, J. L.; Keller, J. Farm irrigation system evaluation: a guide for management. Department of Agricultural and Irrigation Engineering, Logan, UT; 1978.

Ries, R. E.; Day, A. D. Use of irrigation in reclamation in dry regions. Schaller, F. W.; Sulton, P., editors. Reclamation of drastically disturbed lands; 1978.

j. Pest control.

PURPOSE

Grazing by wildlife and competition by weeds are two factors that contribute to seeding failures. Rodents, birds, and ants are common seed-eaters (granivores) in the Powder River-Fort Union Coal Region which can greatly affect the survival rate of seeds that are not covered by soil. Large herbivores, rabbits, hares, and rodents all can take their toll on transplanted or seeded forbs, shrubs, and trees. Since fencing out all of these wildlife species is impossible, other methods are available to substantially decrease the loss of seeds and plantings. Weeds, too, can affect germination success and compete with seedlings for moisture and nutrients and, therefore, must be controlled, either through mechanical or chemical means or by proper timing of planting.

Wildlife Predation on Seeds

Seeds planted by broadcasting (see Section 3.3.1.c, Seeding) are often vulnerable to predation. Studies on rangelands and forests in the northwestern United States have shown over 90% of the seeds are lost to rodents after broadcast seeding (Spencer 1954; Nelson et al. 1970), even after all rodents were previously removed from the site (Sullivan 1979). Goebel and Berry (1976), also working in the Northwest, showed that birds may significantly add to the degradation of a range site because of the preference for seed produced by native bunchgrass or other desirable forage species. Krementz et al. (1981, unpublished manuscript) and others have studied ant consumption of seeds with results varying by region. Krementz et al. found that ants consumed less seed than rodents at the Bridger coal mines in Wyoming's Red Desert, while Pulliam and Brand (1975) found ants consuming 50% more seeds than did rodents in southeastern Arizona.

It is clear from Sullivan's study (1979) in coastal British Columbia that actual removal (poisoning) of rodents has little effect on the amount of depredation because colonization from surrounding areas occurs very quickly. In addition, Reichman (1979), working near Tucson, AZ, found that seed predators adjust their predation levels, depending on the population of other seed predators.

Methods of granivore control which could be used on a reclamation site, if it became necessary, include decreasing seed exposure time through spring sowing, drilling instead of broadcasting or, if broadcasting is essential, then the seed could be covered with a cultipacker. Sowing the seed at a greater depth will help prevent predation but it might also interfere with seedling survival.

If it is not possible to cover the seed soon after sowing, other techniques to reduce predation include using unpalatable seed (once grown, the plants themselves are palatable) or by including a sacrifice species of preferred foods. Through feeding trials, Everett et al. (1978) studied deer mouse seed preference in western Nevada. They concluded that selecting species

less preferred by deer mice, such as flowering saltbush, bulbous bluegrass, sheep fescue, and smooth brome, should reduce the rate of predation of planted seed. Coating preferred seeds with an aversive chemical is another way to reduce predation. Everett et al. (1978) found that coating bitterbrush seeds with alpha-naphthylthiourea (ANTU) reduced their desirability markedly. Marsh et al. (1974) found Douglas fir seeds treated with 4.0%, by weight, ANTU adhered to the seed with a solution of Rhoplex AC-33 prepared at a dilution ratio of 1:7 with water and then dried, repelled deer mice.

Bird predation is a more difficult problem to identify because people do not normally observe bird activity at its peak (Goebel and Berry 1976). Since the numbers of birds are generally low in the Powder River-Fort Union Coal Region, bird predation may not be as great a problem unless seeding occurs at the time a migrating flock is passing through the area. This is likely to occur in the fall when granivorous birds travel in large flocks. Again, covering the seed would lessen the possibility of predation since birds feed by sighting their food.

Wildlife Depredation on Seedlings and Transplants

Herbivore damage to seedlings and transplants can be a significant source of failure and increase the cost of reclamation. Taste repellants or aversives, seedling protectors, and scaring are methods to reduce damage.

The Missoula Equipment Development Center (MEDC) has studied ways to prevent wildlife damage to seedlings. Methods evaluated were fences, noise barriers, special hunting seasons, chemical treatments, habitat manipulation, and individual seedling protectors (Knudson 1972). MEDC investigators found that individual seedling protectors were far superior to any of the other protection methods.

Vexar seedling protectors are manufactured by DuPont and are available in diamond, twill, or mesh patterns. Recommended tube lengths are 0.5 m (1.5 ft) for established stock and 1.5 m (5 ft) for hardwoods (Larson et al. 1979). Plastic tube seedling protectors are photodegradable and eventually break down when exposed to sunlight. The time required for breakdown is determined by the color of the plastic. Translucent green tubes with 5.0% ultraviolet inhibitor will provide 3.5 to 4.5 years of protection.

MEDC also did tests on support mechanisms for Vexar tubes (Larson et al. 1979). They evaluated wooden laths, spiral pins, straight pins, plastic stakes, short wooden stakes with locking nails, and wooden dowels. Results showed that two straight wires with hooks or two spiral wires provide sufficient support if the ground is not rocky or steep. Short wood stakes with locking nails should be used on areas that are rocky, steep, under heavy snowpack, or extensively used by elk.

At the Consol Glenharold Mine in Stanton, ND, Vexar seedling protectors are being used. This method has been tested and used with success in reforestation in the Pacific Northwest.

Thiram (Arasan) is a taste repellent which can be applied to trees, seedlings, and shrubs for protection from rabbits, mice, ground squirrels, and large ungulates (Hawthorne 1980). This product is available in aerosol sprays, a 20% solution to be diluted with water, and in a 42% concentrate to make a mixture of water and sticker. The plant should be sprayed thoroughly before damage begins. This product cannot be used on plant parts that will be eaten by humans or domestic animals. Livestock would have to be fenced from an area where Thiram was being used.

Deer-Away Big Game Repellent protects seedlings from browsing by deer and elk. This is a two-part product and must be mixed together before use at the rate of one part Concentrate 2103, one part Formula 2104, and six parts water, and must be used the same day of mixing. To protect against winter browsing, the repellent should be applied as close as possible to onset of browsing, but after seedlings are dormant and frost-hardy. For protection of new growth against spring browsing, treatment should start as soon as buds have fully opened and begun to elongate. One gallon of diluted repellent, applied from a pressurized hand sprayer to the point of run-off of repellent from the foliage, will treat about 400 seedlings that are 0.5 to 1 m (1.5 to 3 ft) tall.

Noise makers, flashing lights, or other visual repellents have been used to frighten deer away from plantings. Such devices provide fair success when first used, but prove ineffective as long-term repellents. Animals become accustomed to the noise or light and eventually ignore it unless a combination of devices are used. Woven wire fences 2.4 m (8 ft) high are recommended to exclude antelope, deer, and elk (see Section 3.1.1.d, Fences).

It has been suggested that providing habitat for predators, such as roosts, nest boxes, and rock piles, may provide a rodent control mechanism. Because of the high reproductive rate of rodents and their ability to move in quickly from elsewhere, it is unlikely that predators, such as kestrels, can actually provide adequate population control. However, some success has been reported. Rodent damage in a grassland habitat was significantly reduced by planting a snag (dead tree) in the middle of the area, which served as a hunting perch for raptors (Dick Hodder, Montana State University, pers. comm.). Such snags may also enhance the value of the area for perching birds. Peter Kiewit Son's in Sheridan, WY and Pittsburg-Midway near Steamboat Springs, CO are experimenting with kestrel nest boxes on some of their reclamation areas and should have more information on the success of this technique.

A variety or a combination of methods to control predation on both seeds and seedlings may have to be tried before success is achieved. The results of the described techniques are often unpredictable and may be expensive, but may be worth trying if predation is threatening to destroy the reclamation program.

Weed Control

Fall seeding is a common practice in the reclamation of coal mines in the Powder River-Fort Union Coal Region. If land shaping is finished in the late fall or spring and seeding is not done until the following fall, weedy growth can be abundant. The control of weeds during the summer growing season or

summer "fallowing" prevents weeds from going to seed, thereby reducing the likelihood of thick stands of weeds competing with the newly emerged seedlings.

Summer fallowing can be done by tilling the soil or through the application of preemergence and/or postemergence herbicides. Neither burning nor mowing is an effective means of summer fallowing (Cook et al. 1974). Preemergence herbicides are effective for annual grasses, while postemergence herbicides affect broad-leaved plants and should not be used where shrubs and trees are transplanted or must be saved. The application of herbicides as a summer fallow practice gives significantly better stands of seeded vegetation than untreated areas where the seed is drilled directly into the weedy growth of annuals.

Tillage is difficult and costly on steep or rocky slopes and the effectiveness would be reduced. However, the advantages of tillage on level ground is that working with chemicals can be avoided.

Common problem weeds in the Powder River-Fort Union Coal Region are Canada thistle, whitetop, prickly lettuce, Russian thistle, and leafy spurge. The Soil Conservation Service recommends aerial or hand spray treatment with 2,4-D (2,4-dichlorophenoxyacetic acid) or other appropriate herbicides. For information on current recommended application rates, contact the Soil Conservation Service, Environmental Protection Agency, and/or State Regulatory Authority.

The Environmental Protection Agency keeps a registry of legal pesticides which have an EPA registration number on the label, as well as a list of uses. To use EPA-restricted-use pesticides, State certification is required. For information on restricted-use pesticides and on obtaining a commercial applicator's license, contact the appropriate State agriculture agencies.

LABOR/MATERIALS

Many of the granivore control techniques would not increase the cost of seeding appreciably. Sowing seed in the spring instead of fall, making sure the seed is covered, and using less palatable species are inexpensive changes that could be made if seed predation is a problem. Rolled barley at \$6/22.7 kg (50 lbs) and Lab Chow at \$15/22.7 kg (50 lbs) can be mixed with seed. The number of pounds per ha (acre) to use would have to be derived experimentally, but the cost is minimal.

Taste repellants to protect shrubs, tree, and seedlings cost approximately \$20 to \$35/3.8 gal. Approximately 400 seedlings can be treated with 3.8 gal (1 gal). Labor time for 400 seedlings would be approximately five hours (Jack Terry, International Reforestation Suppliers, pers. comm.).

Plastic mesh tubes to protect seedlings can be obtained for \$0.20 to \$0.36 per tube, depending on the manufacturer, quantity, diameter, and freight

charges. Application rate for each tube, stakes, and tie would be approximately two to three minutes. For 400 seedlings, the labor time would be 13 to 20 hours.

SOURCES OF INFORMATION

- o State Regulatory Authority
- o Office of Surface Mining
- o State Game and Fish agencies
- o U.S. Forest Service
- o U.S. Bureau of Land Management
- o County Agricultural Extension Agents
- o U.S. Soil Conservation Service
- o State Agricultural Experiment Stations

For addresses, see Appendix A.

References Cited:

- Cook, C. W.; Hyde, R. M.; Sims, P. L. Revegetation guidelines for surface mined areas. Colorado State Univ. Science Series No. 16; 1974. 74 p.
- Everett, R. L.; Meenwig, R. O.; Stevens, R. Deer mouse preference for seed of commonly planted species, indigenous weed seed, and sacrifice foods. J. Range Manage. 31(1):70-73; 1978.
- Goebel, C. J.; Berry, G. Selectivity of range grass seed by local birds. J. Range Manage. 29(5):393-395; 1976.
- Hawthorne, D. W. Wildlife damage and control techniques. Pages 411-440 in Schemnitz, S. D. ed. Wildlife management techniques manual. Washington, D.C.: The Wildlife Society; 1980.
- Knudson, R. S. Survey of current methods for seedling protection. USDA Forest Service, MEDC Project Record; 1972.
- Kremetz, D. G.; Stanton, N. L.; Pentecost, E. D. Granivore communities on reclaimed mine spoils of northern desert shrub-steppe. Unpublished manuscript available from Dept. of Zoology, U. of Western Ontario, London, Ontario, Canada; 1981.
- Larson, J. E.; Campbell, D. L.; Evans, J.; Lindsey, G. D. Plastic tubes for protecting seedlings from browsing wildlife. Report on Equipment Development and Test Project 2217-Plastic Tube Seedling Protectors. USDA Forest Service; 1979.
- Marsh, R. E.; Passof, P. C.; Howard, W. E. Anticoagulants and alpha-naphthylthiourea to protect conifer seeds. Black, H. E., ed. Wildlife and forest management in the Pacific Northwest. Oregon State Univ.; 1974.

- Nelson, J. R.; Wilson, A. M.; Goebel, J. Factors influencing broadcast seeding in bunchgrass range. *J. Range Manage.* 23; 1970.
- Pulliam, H. R.; Brand, M. R. The production and utilization of seeds in plains grassland of southeastern Arizona. *Ecology* 56; 1975.
- Reichman, O. J. Desert granivore foraging and its impact on seed densities and distributions. *Ecology* 60(6); 1979.
- Spencer, D. A. Rodents and direct seeding. *J. For.* 52; 1954.
- Sullivan, T. P. Repopulation of clear-cut habitat and conifer seed predation by deer mice. *J. Wildl. Manage.* 43(4); 1979.

k. Grazing management to allow vegetation recovery.

PURPOSE

Grazing is the primary land use on much of the reclaimed mined lands in the western United States, but without some follow-up level of management, even the best plant stands can be destroyed by excessive or improper grazing (Institute for Land Rehabilitation 1978). The ultimate success of revegetation depends upon post-revegetation management. However, until the operator's bond is released on a given parcel of land, the State regulatory authority will determine what grazing practices should be used. The mining company should, therefore, work with the State regulatory agency and the Office of Surface Mining to determine the need for, and level of, post-revegetation management.

DEVELOPMENT

The immediate goal of a reclamation program should be to reestablish vegetation growth for site stabilization and soil cover before allowing grazing to commence. Young plants and seedlings do not develop well when cropped or trampled by large or small animals (Yoakum and Dasmann 1971). In seeded stands, the best rule to follow is to exclude grazing animals until the plants have become sufficiently established to withstand grazing (Institute for Land Rehabilitation 1978). Vallentine (1971) suggests that seeded or planted areas should not be grazed until after the second full growing season following seeding. Fencing to exclude large grazers and repellants to deter small mammals are some of the measures that can be employed to protect newly established vegetation (see Section 3.1.1.d, Fences, and Section 3.3.1.j, Pest Control).

In designing a grazing management program, it is important to understand that forage competition between domestic and native animals can be a major factor in both livestock and wildlife production. The degree of this competition depends upon the similarity in diets, the kind and amount of forage present, the relative size and numbers of domestic and wild herbivores, the intensity of grazing, and the degree to which they use the same part of the range (Stoddart et al. 1975). To minimize competition and to help ensure the success of the reclamation program for both wildlife and cattle, grazing management programs should be concerned not only with plant productivity, but also with diversity.

Berg (1975) recognized three grazing-forage management alternatives which he suggested be adopted for reclamation plans. These three alternatives are:

- o use of revegetated areas for special use pastures, with emphasis on establishment of a limited number of highly productive, probably introduced plant species (this alternative would rarely be implemented on Federal land, but may be a viable practice on private land, although it may require land use change approval by OSM or the State regulatory authority);

- o pastures of more general livestock use, primarily composed of native plant species; and
- o special use areas for wildlife, emphasizing establishment of suitable browse species.

Grazing management for livestock includes deferred grazing, rotation grazing, deferred rotation grazing, and rest rotation grazing (Stoddart et al. 1975). Deferred grazing refers to delaying grazing for some period of time during the growing season. An example of a deferred rotation system in which units are ungrazed during winter is (Stoddart et al. 1975):

<u>Year</u>	<u>Unit 1</u>	<u>Unit 2</u>	<u>Unit 3</u>
1	Spring	Summer	Fall
2	Spring	Summer	Fall
3	Summer	Fall	Spring
4	Summer	Fall	Spring
5	Fall	Spring	Summer
6	Fall	Spring	Summer

This system has some theoretical advantage in that forage plants are given a better opportunity to reproduce, delaying grazing until after the seed matures causes less injury to plants, and animals scatter and trample the seeds into the soil promoting establishment. In rotation grazing, the range is subdivided into units and each unit is grazed in succession. This system is based on the assumption that animals in large numbers make a more uniform use of the forage and that a rest from grazing is beneficial to the plants.

With the deferred rotation system, grazing is deferred on one part of the range during one or more years. By rotation, other areas are successively deferred until all have been deferred. The system consists of dividing a given range into two subunits, A and B. Animals are placed on unit A for the first half of the season to allow seed to mature on unit B. No animals are placed on B. This pattern is followed for two years. During the third year, Unit B is grazed during the first half of the year and A is allowed to mature seed. After two more years, the original order is followed. Three pastures are commonly used in this system, but there may be as many as ten.

The deferred part of the range is given complete rest for an entire year in the rest rotation system. The system has been widely used in areas where seasonal grazing is practiced and cool-season grasses make up most of the vegetation (Stoddart et al. 1975).

Another system developed for large, arid areas places all grazing animals into one unit. All other units are deferred. Animals are moved to another unit when 50% of the forage has been utilized.

At the Caballo Mine (Carter Mining Co.), Gillette, WY, a deferred grazing system is proposed for the reclaimed lands. Depending on the success of the

seeding, grazing is proposed to resume as early as the third season after planting. Grazing use would be deferred through the growing season during the three years immediately after planting. Light grazing use of 15% of the forage production would be allowed beginning no earlier than September 1.

The deferred grazing system would continue through the sixth year, with annual adjustments which account for variations in moisture and forage production. During years 7 through 10, the deferred grazing system would begin earlier in the year and grazing would increase to a 30 to 40% use of available forage. The management plan contains provisions to fence the lands and provide a stock watering facility for at least every square mile when sufficient reclaimed lands become available to provide a viable grazing area.

The Rosebud Mine (Western Energy Co.) will utilize a deferred-rotation grazing system on their postmined lands. A rest-rotation system will be implemented if it becomes apparent the deferred-rotation system is not producing the desired results. Deferred-rotation will be implemented at the end of the third growing season. Pastures will remain ungrazed during the winter. At the Rosebud Mine site, grazing of the entire unit will take place during the first year to allow for maximum livestock production and utilization of all forage plants. During year two, grazing will be deferred on the unit until after seed production to allow for vigor, seed production, and seed trampling. Grazing will be deferred on the unit in the third year until after flowering time to allow for seedling establishment.

In regards to the number of cattle that should be allowed to graze a particular range, the following rule of thumb should be applied. The maximum number of cattle that can be carried on any unit of land is the number that can be supported during a poor season (Stoddart et al. 1975). Ranges in most western States can support one animal unit on 10 to 32 ha (25 to 80 acres) per year. Each of the described grazing systems assumes that fencing will be used to control livestock. These systems also require a distribution of water sufficient to support the herd.

A variety of methods are available for keeping livestock away from a particular site. Indirect methods for accomplishing this are less costly than direct methods and include (Bjugstad 1979):

- o adding less palatable species to the seed mixture;
- o salting at least 0.4 km (0.25 mi) from the seeded area; and
- o providing permanent water away from the seeded area and fencing out nearby water.

Direct methods include the use of barriers, either of metal or wood, and ranging from barbed-wire fences to brush piles. Repellants have been developed for wild ungulates and are sometimes effective for sheep and cattle. Repellants specifically for livestock have not been fully developed. Herding may also be tried, although this requires the use of herders to keep the animals contained.

MAINTENANCE AND MANAGEMENT

Management to control grazing will require a concerted effort. However, the effort involved should be no more than would be expected on unmined lands. The procedures which have been described are those that would be required for any successful grazing operation. Costs should be expected to equal those of any other similar operation.

SOURCES OF INFORMATION

- o State Regulatory Agency
- o Office of Surface Mining
- o U.S. Soil Conservation Service
- o County Agricultural Extension Agents
- o U.S. Forest Service
- o U.S. Bureau of Land Management

For addresses, see Appendix A.

References Cited:

- Berg, W. A. Revegetation of land disturbed by surface mining in Colorado. Wali, M. K., ed. Practices and problems of land reclamation in western North America. Univ. North Dakota Press: Grand Forks, ND; 1975.
- Bjugstad, A. J. Management plan and monitoring. User guide to vegetation. Mining and reclamation in the West. USDA Forest Service Gen. Tech. Rep. INT-64: Intermtn. For. and Range Exp. Stn., Ogden, UT; 1979. 85 p.
- Institute for Land Rehabilitation. Rehabilitation of western wildlife habitat: A review. Washington, D.C. U.S. Fish and Wildlife Service, FWS/OBS-78/86; 1978.
- Stoddart, L. A.; Smith, A. D.; Box, T.W. Range management. New York: McGraw-Hill; 1975.
- Vallentine, J. F. Range development and improvements. Brigham Young University Press: Provo, UT; 1971.
- Yoakum, J.; Dasmann, W. P. Habitat manipulation practices. Giles, R. H., ed. Wildlife management techniques. Washington, D.C.: The Wildlife Society; 1971.

3.3.2 Water Resource Improvement and Development

a. Final cut lakes as permanent impoundments. Historically, Montana, North Dakota, and Wyoming have had final cut lakes left as permanent impoundments. Recently, however, Federal and State regulations began limiting the retention of this type of impoundment on reclaimed surface mines. The objective of the final cut regulations were to return the cut to its approximate original contour with all highwalls, spoil piles, and depressions eliminated. There is, however, a provision in the law allowing the mine operator a variance from this requirement if a proposed alternative postmining land use of the lake is deemed an equal or better economic or public use of the land compared to its premine utilization.

Various uses of final cut lakes have been proposed, including recreation, livestock watering, irrigation or community water supply, and fish and wildlife use. Problems arise when trying to determine the design criteria which should be met in order for the final cut lake to be practical in its postmining land use objective. A study has recently been completed, funded by the Office of Surface Mining, to assist operators with these and other problems associated with final cut lakes (Nelson et al. 1982). This manual is expected to address many of the problems associated with final cut lakes and set recommendations on design criteria and management of proposed permanent impoundments. Because of the comprehensive and definitive nature of this study, it is recommended that operators obtain a copy of this publication prior to considering the use of final cut lakes as permanent impoundments. Information on this manual can be obtained by writing to the following address:

Asst. Director for Technical Standards and Research
Office of Surface Mining
1951 Constitution Ave., N.W.
Washington, D.C. 20240

SOURCES OF INFORMATION

References Cited:

Nelson, R. W.; Osborn, J. F.; Logan, W. J. Planning and management of mine cut lakes at surface coal mines. U.S. Dept. Int., Office of Surface Mining, Washington, DC; OSM TR-82/1; 1982.

b. Supplementary water resources.

PURPOSE

Water is an essential requirement of most wildlife and, in some areas, such as the Northern Great Plains, is the key component dictating habitat use and population levels. Water holes in the semiarid West are often the center of wildlife activities, but the paucity of natural water impoundments on the unglaciated portion of this xeric region has placed the value of water for wildlife at a premium. Thousands of man-made ponds constructed for livestock use have alleviated this problem somewhat; however, water in this region is still locally limited.

Water developments extend the ranges of many species. Yoakum et al. (1980) provide an example of an area formerly void of natural surface waters where wildlife managers channeled water from an artesian well into a small excavated pond. The pond ultimately supported over 155 different species of wild mammals, birds, fishes, and amphibians. Such areas not only provide an animal's water requirements, but also create additional habitat and increase local species diversity. Creating supplementary water impoundments in the semiarid coal regions of Wyoming, Montana, and the Dakotas may greatly enhance the distribution, numbers, and diversity of wildlife in an otherwise hostile habitat.

DEVELOPMENT

The design and specifications below represent those of a basic embankment pond, the versatility of which promotes maximum utilization by a broad variety of wildlife species. Modifications for enhancing individual species are provided elsewhere in this publication (see Section 3.3.2.c, Creating Impoundments for Waterfowl, and Section 3.3.2.e, Creating Impoundments for Fish) or in the references cited in this section. General considerations for wildlife needs are:

- o Water sources should be present year-round to optimize benefits to wildlife. Ponds should be designed for at least a 20-year lifetime.
- o Several small, irregularly shaped ponds are more desirable than one large, uniformly shaped pond, particularly if they are dispersed.
- o Wildlife should have easy access to the water. Shoreline slopes should pitch at a gradient of 5 to 1 or less. Shorelines with gentle slopes also have minimal erosion problems.

The following are site/design considerations which should be incorporated into the selection of water impoundment sites:

- o Surface runoff and snowmelt are the primary water sources for these ponds. Ponds must be sited so that the watershed supporting them is of adequate area to provide sufficient water to replenish the reservoir annually, yet not so large that peak

runoff damages the spillway or the dam. The characteristics determining the amount of annual runoff are numerous and highly variable; however, 20.2 to 24.3 ha (50 to 60 acres) per acre foot of pond storage are generally required for this region (SCS 1971).

- o To facilitate revegetation and to comply with regulatory requirements, reclamation efforts often reestablish a moderate overall topography. If the reclaimed area is too flat, too high above groundwater aquifers, or lies in a drainage area inadequate to yield the required runoff to fill the reservoir annually, then the impoundment may be built on suitable, adjacent, undisturbed lands. Even when siting on undisturbed lands, areas disturbed during pond construction should be immediately revegetated to prevent excessive sediment loading. Proper planning should also mitigate runoff leaching and the transportation of toxic substances into the reservoir from tailings, overburden, and waste rock disposal and soil storage sites.
- o Water depths in some portion of the pond (33% is recommended by the SCS) should be at least 3 to 3.7 m (10 to 12 ft) in the Northern Great Plains, to ensure the presence of surface water year-round (SCS 1971). Deeper portions are required if a permanent water supply is essential or where seepage exceeds three inches per month (SCS 1971). This deep pool will provide the last remnant of water when the rest of the pond has dried up. In the wetter months, the pool should overflow and provide shallow water habitat. Surface area of the deep pool should be minimized to reduce evaporative losses. A moderate slope should be retained around some portions of the deep pool to allow access by wildlife at all water levels. Pond size will vary with runoff accumulation.
- o Proper impoundment siting is the most important step in pond construction from a wildlife and economic standpoint. Prior to construction, the topography, surface hydrology, geochemistry, vegetation, wildlife use patterns, and construction costs should be reviewed. Catchment basins along ephemeral streams are often the best sites for impoundment siting, especially in areas where the surrounding vegetation is comprised of bluegrasses, sedges, asters, or other wet meadow flora indicative of periodic flooding. Furthermore, construction costs can be lowered by using natural drainage systems where use of earth-moving equipment can be minimized.

The value of sedimentation ponds to wildlife varies greatly, depending on the level of toxic effluents present. These ponds may offer a great potential for wildlife enhancement to the mine company. If the design of such ponds intended for less toxic pollutants would also consider wildlife needs, the company could provide a highly beneficial postmining habitat with little additional cost.

ENGINEERING CONSIDERATIONS

Ponds can be excavated with tractor-pulled wheeled scrapers, bulldozers, or draglines. Prior to compacting the pond bottom, soil composition should be checked to ensure a minimum composition of 20% clay or other impervious material. If soils are too porous, a sealer, such as bentonite, can be mixed into the soil with a disk. A sheepsfoot roller can be used to compact the pond bottom. The deep portion of the pond can be excavated immediately upstream of the dam and the excavated material used in dam construction. Dam construction and engineering specifications for the materials used in the dam and spillway, the dimensions of each, the associated valves and instrumentation, and appropriate methods of excavation are described in Agriculture Handbook No. 387 (SCS 1971) and Technical Guide No. 378 (SCS 1980). Other related engineering standards and specifications for impoundment creation are available from the Soil Conservation Service and are identified below.

Creating supplementary water resources on or adjacent to coal lands, like all reclamation practices discussed in this publication, is obviously contingent upon the surface owner's land-use goals. Reclamation efforts would be possible under any of the following conditions:

- o adjacent or reclaimed land is owned by the mining company;
- o the owner of reclaimed or adjacent land wishes his or her land to be improved for wildlife; or
- o reclaimed or adjacent land is Federal or State owned and an agreement is made following multiple use guidelines.

REGULATORY SPECIFICATIONS FOR PERMANENT IMPOUNDMENTS

The first step for a coal mine operator planning to retain a permanent impoundment is to consult with the State regulatory agency. In Wyoming, the Department of Environmental Quality, Land Quality Division is the regulatory authority. The Water Quality Division grants the permit to create an impoundment and also the National Pollutant Discharge Elimination System (NPDES) permit. The State Engineer's office must be consulted if the impoundments are larger than 2.2 ha-m (20 acre-ft) or if water rights are in question. General design criteria for sediment ponds and permanent impoundments are specified in the "Rules and Regulations" (Wyoming Department of Environmental Quality 1981). The primary concern is that the impoundments have geotechnically stable dams, sealed and relatively inert pond bottoms, protection from excessive erosional products, pond water quality that will support a postmining land use equivalent to or greater than the premining land use, and discharge of water from the impoundment that will not degrade the quality of the receiving waters. The Montana and North Dakota regulatory agencies have comparable rules and regulations. These agencies refer the mine operator to several publications of the Soil Conservation Service (SCS 1971, 1976, 1980) for the engineering specifications to be followed in the design, construction, and maintenance of permanent impoundment structures. In light of the fact that techniques and procedures for the creation of supplemental water resources have yet to be tested with respect to enhanced wildlife use in the Northern

Great Plains, the guidelines presented in the Soil Conservation Service Technical Guide No. 378, "Ponds," are considered the best way to proceed for the present. In the future, some of the standards and specifications may be modified when the planned land use is primarily for wildlife (including livestock). Pond siting and construction criteria that are relevant to wildlife use are listed below:

- o Minimum distance between ponds in undulating prairie land should be 1.2 to 1.6 km (0.75 to 1 mi); in the foothills or on rolling land, the distance between ponds should be no less than 0.6 to 1.2 km (0.38 to 0.75 mi).
- o Ponds must have an effective life of 25 years. The drainage area should be large enough to ensure adequate water storage.
- o Water quality shall be suitable for the intended land use.
- o Ponds should have minimum size of 0.1 surface ha (0.25 surface acres).
- o No more than 20% of the pond surface shall have a depth less than 0.6 m (2 ft) when the pond is full.
- o The side slopes of the embankments shall be no steeper than 5 horizontal: 1 vertical, averaged over upstream and downstream sections.
- o Slopes must be of stable material.
- o The embankment dam is required to have an emergency spillway to prevent flood damage to pond.

LABOR/MATERIALS

Construction and reclamation costs are estimated in the bonding section of the mine permit application that each operator submits to the State regulatory agency. Costs are quite variable, depending on the mine site, geology, availability of equipment, the size of the ponds, etc. Cost of most "average" 0.4 to 0.81 ha (1- to 2-acre) ponds in this region run between \$35,000 and \$50,000 (Sam Scott, Peter Kiewitt Son's, pers. comm.); however, ponds beneficial to wildlife can be built far less expensively. Energy Development Co. excavated a 0.7 ha-m (6 acre-ft) pond in about 8 hours with a "D9 Cat" at a cost of about \$1,000 for the operation of the machine and labor. If the equipment had been rented, the price would have doubled. Engineering and permitting costs add significantly to the final cost.

Many operators simply convert sediment control ponds to permanent impoundments. In these cases, most costs are absorbed as part of normal mine operations, and the only additional cost is that of cleaning up the impoundments and converting them.

The major cost of most impoundments is incurred from permitting requirements. The applicant must guarantee dam stability, quantity and quality of water, etc. (as described above) for the proposed use. Water quality must be monitored, which often includes expensive laboratory procedures.

It is expensive to create water impoundments and later destroy the reservoir to reclaim the land. For this reason, operators appear interested in working with regulatory agencies to develop a set of procedures and methods that would allow sediment ponds to be cleaned, modified, and left as final impoundments that wildlife and livestock could use.

SOURCES OF INFORMATION

- o State Regulatory Authority
- o Office of Surface Mining
- o U.S. Fish and Wildlife Service
- o U.S. Bureau of Land Management
- o U.S. Soil Conservation Service
- o State Game and Fish Agencies

For addresses, see Appendix A.

References Cited:

- Soil Conservation Service. Ponds for water supply and recreation. Agricultural Handbook No. 387; 1971.
- Soil Conservation Service. Earth, dams and reservoirs. Tech. Release No. 60; 1976.
- Soil Conservation Service. Ponds. Practice Standard 378. SCS Denver, CO; 1980.
- Wyoming Department Environmental Quality. Rules and Regulations. Cheyenne, WY; 1981.
- Yoakum, J.; Dasmann, W. P.; Sanderson, H. R.; Nixon, C. M.; Crawford, H. S. Habitat improvement techniques. Schemnitz, S. D. ed. Wildlife management techniques manual. The Wildlife Society, Washington, D.C.; 1980.

Additional References:

- Moore, R.; Mills, T. An environmental guide to western surface mining. Part Two: Impacts, mitigation and monitoring. U.S. Fish and Wildlife Service, FWS/OBS-78/04; 1977.

c. Creating impoundments for waterfowl.

PURPOSE

The Powder River-Fort Union Coal Regions of Wyoming, Montana, and North Dakota are located in the semiarid prairie where the surface water acreage is relatively low. These coal regions are adjacent to the glaciated prairie region of the central plains. In the pothole region of North Dakota alone, there are an estimated 3.2 million acres of ponds (Stewart and Kantrud 1972) where 1.6 million pairs of ducks breed annually (Stewart and Kantrud 1974). Each spring about 75,000 to 100,000 geese and 50,000 to 225,000 ducks migrate over the two coal resource areas en route to the pothole wetlands (Bellrose 1976). These waterfowl make temporary use of prairie playas, catchment basins along ephemeral streams, and stock ponds. Relatively small numbers of mallards, pintails, blue-winged teals, American wigeons, and other waterfowl remain in the Powder River-Fort Union Coal Region, to breed and rear their young. The densities of waterfowl are limited by the extent and type of water bodies available. Lokemoen (1973), Ruwaldt et al. (1979), and others have shown that waterfowl, particularly mallards and gadwalls, will readily make use of new, man-made impoundments, provided they have the appropriate habitat features (Flake et al. 1977). By creating more permanent impoundments with suitable cover and food resources, waterfowl production will be enhanced in the Powder River and Fort Union Regions (Brewster et al. 1976).

DEVELOPMENT

Adequacy of Habitat

Thirteen species of waterfowl (blue-winged teal, mallard, pintail, American wigeon, gadwall, northern shoveler, green-winged teal, cinnamon teal, redhead, lesser scaup, canvasback, ruddy duck, and Canada goose) breed and rear their young in the two coal regions (Lokemoen 1973). The most common species are the first five listed above. Newly constructed impoundments designed for waterfowl should consider habitat needs of these species first. All five are dabbling ducks and require shallow (0.6 m; 2 feet or less) areas to feed in. Small, irregularly shaped ponds with emergent vegetation and islands provide areas for courtship, nesting, and brood raising. Flake et al. (1977) examined 28 habitat variables and found that pond size and distance between ponds were positively correlated with the presence of breeding pairs of mallards and gadwalls. The areal extent of emergent vegetation and percent of semi-open marsh were key features that attracted blue-winged teal and American wigeons. In addition to differences in species habitat preferences, ducks sought different environmental conditions as they age. Patterson (1976) showed that the number of breeding pairs of ducks was most closely correlated with pond size, the number of broods correlated with the suitability of escape cover and food, and fledgling numbers were positively correlated with wetland fertility. As a result, a small group of ponds would be more advantageous to waterfowl production than one large pond.

Design Features

Impoundment design should follow that suggested in Section 3.3.2.b (see especially the regulatory specifications) with the exceptions that 50 to 75% of the pond should consist of water less than 0.6 m (2 ft) deep, the pond should be irregularly shaped, and contain islands and side channels. The shallow areas suited for waterfowl feeding and emergent plant growth in turn make the pond more attractive for waterfowl nesting and brood rearing. A deep basin may attract diving ducks and serve as a prairie oasis in times of drought. Ideally, several ponds may be excavated within 0.4 km (0.25 mi) of the reservoir.

Specific design features of ponds that appear most suitable for waterfowl production have been reviewed by Lokemoen (1973), Patterson (1976), Flake et al. (1977), and Eng et al. (1979). These include:

- o Pond density: 2 to 3 ponds/2.59 km² (1 mi²).
- o Pond size: 0.4 to 4.0 ha (1 to 10 acres); 0.4 to 2.0 ha (1 to 5 acres) optimal.
- o Pond depth: Eng et al. (1979) recommend 50 to 75% of a pond be less than 0.6 m (2 ft) deep; the Wyoming Game and Fish Department (1977) suggests that no more than 30% of the pond be less than 0.9 m (3 ft) deep.
- o Pond configuration: Irregular with islands and side channels.
- o Islands: 0.009 to 0.06 ha (0.01 to 0.15 acres) in size, vegetated, at least 9.1 m (30 ft) from shore with a greater than 0.46 m (1.5 ft) channel depth between island and mainland (see Section 3.3.2.d, Island Development for Waterfowl).
- o Vegetation: Sedges, spikerush, smartweed, rushes, and duckweed are most likely pioneer species, but can be transplanted (rootstock, entire plant); emergents require water depths greater than 0.9 m (3 ft) to develop.
- o Fencing: Not required, provided some shoreline areas (e.g., islands) are kept free from excessive grazing pressure.

Engineering Considerations

If several satellite ponds are created in addition to damming the drainage system, they should be constructed first. The excavated material can be used in constructing the dam and islands of the main reservoir. When complete, these ponds should look like prairie playas and fill seasonally with surface

drainage. To ensure a maximal water supply, annual runoff must be accurately estimated and pond size adjusted accordingly. The dam construction procedures and engineering specifications outlined in Agriculture Handbook No. 387 (SCS 1971) may be recommended, but it is essential that the operator consult with the State regulatory authority before beginning construction of any impoundments on the mine permit area.

MAINTENANCE AND MANAGEMENT

Impoundment maintenance is required, and the State regulatory authority will provide guidance as appropriate.

LABOR/MATERIALS

The number of man-hours required depends upon the size, complexity, and location of the impoundment. Construction can be accomplished with heavy equipment normally used during mining and/or reclamation activities. Cost of most 0.4- to 0.81-ha (1- to 2-acre) ponds in this region averages between \$35,000 and \$50,000 (Sam Scott, Peter Kiewitt Son's, pers. comm.). Additional cost and labor estimates are provided in Supplementary Water Resources, Section 3.3.2.b.

SOURCES OF INFORMATION

- o State Regulatory Authority
- o Office of Surface Mining
- o U.S. Fish and Wildlife Service
- o U.S. Bureau of Land Management
- o State Game and Fish Agencies

For addresses, see Appendix A.

References Cited:

- Bellrose, F. C. Ducks, geese and swans of North America. Stackpole Books, Harrisburg, Pa.; 1976.
- Brewster, W. G.; Gates, J. M.; Flake, L. D. Breeding waterfowl populations and their distribution in South Dakota. J. Wildl. Manage. 40(1):50-59; 1976.
- Eng, R. L.; Jones, J. D.; Gjersling, F. M. Construction and management of stockponds for waterfowl. U.S. Dept. Interior, Bureau of Land Management Tech. Note No. 327; 1979.
- Flake, L. D.; Peterson, G. L.; Tucker, W. L. Habitat relationships of breeding waterfowl on stockponds in northwestern South Dakota. Proc. S. Dak. Acad. Sci. 56:135-151; 1977.

- Lokemoen, J. T. Waterfowl production on stockwatering ponds in the northern plains. *J. Range Manage.* 26(3):179-184; 1973.
- Patterson, J. N. The role of environmental heterogeneity in the regulation of duck populations. *J. Wildl. Manage.* 40(1):22-32; 1976.
- Ruwaldt, J. J., Jr.; Flake, L. D.; Gates, J. M.: Waterfowl pair use of natural and man-made wetlands in South Dakota. *J. Wildl. Manage.* 42(3):375-383; 1979.
- Soil Conservation Service. Ponds for water supply and recreation. *Agricultural Handbook No. 387*; 1971.
- Stewart, R. E.; Kantrud, H. A. Ecological distribution of breeding waterfowl populations in North Dakota. *J. Wildl. Manage.* 37(1):39-50; 1972.
- Stewart, R. E.; Kantrud, H. A. Breeding waterfowl populations in the prairie pothole region of North Dakota. *Condor* 76:70-79; 1974.
- Wyoming Game and Fish Department. Considerations for wildlife in industrial development and reclamation. *Wyoming Game and Fish Dept., Cheyenne*; 1977.

d. Island development for waterfowl.

PURPOSE

Small islands in permanent impoundments can provide an effective means of reducing terrestrial mammalian predation on waterfowl and their nests by providing sites which are relatively inaccessible (Figure 3.3-7). A number of species of waterfowl and shorebirds will benefit from such development. It has been shown from several studies that nesting success as high as 90% has been recorded for islands, compared to 20% for mainland-nesting individuals. Islands are also attractive to waterfowl because they represent places where general disturbance is minimized and the birds can rest undisturbed.



Figure 3.3-7. Aerial view of an island created for waterfowl on a surface mine reservoir (photo courtesy of North American Corporation).

DEVELOPMENT

Islands can be easily and inexpensively incorporated into the construction of the permanent impoundment. Islands should be 0.02 ha (10 x 20 m) or larger, with their distance from the mainland depending on each individual situation. In Alberta, it was found that channels 0.5 to 0.6 m (1.5 to 2 ft) deep and approximately 9 m (30 ft) wide between the island and the mainland were adequate (Keith 1961). Another study recommended long, narrow islands at least 15 m (50 ft) from the shore on impoundments larger than 0.8 ha (2 acres) (McCarthy 1973). Hook (1973) found that, on large water bodies, a minimum of 33 m (150 ft) between islands minimizes territorial strife and encourages nesting in Canada geese.

During impoundment construction, potential high points and deltas within the reservoir can be built up, while land which was previously a peninsula can be separated from the mainland (Figure 3.3-8). The location of islands with respect to the prevailing wind direction on large bodies of water represent special problems. Islands should be protected from strong wave action, which encourages erosion. Plantings on the mainland can reduce winds, while plantings on the island or in the shallow areas around the island can reduce wave erosion (see Section 3.3.3.c, Creating Wind and Snowbreaks for Winter Wildlife Protection, and Section 3.3.1.c, Seeding). Islands at least one meter (3 ft) high are recommended to avoid nest destruction due to flooding and eventual settling of the ground.

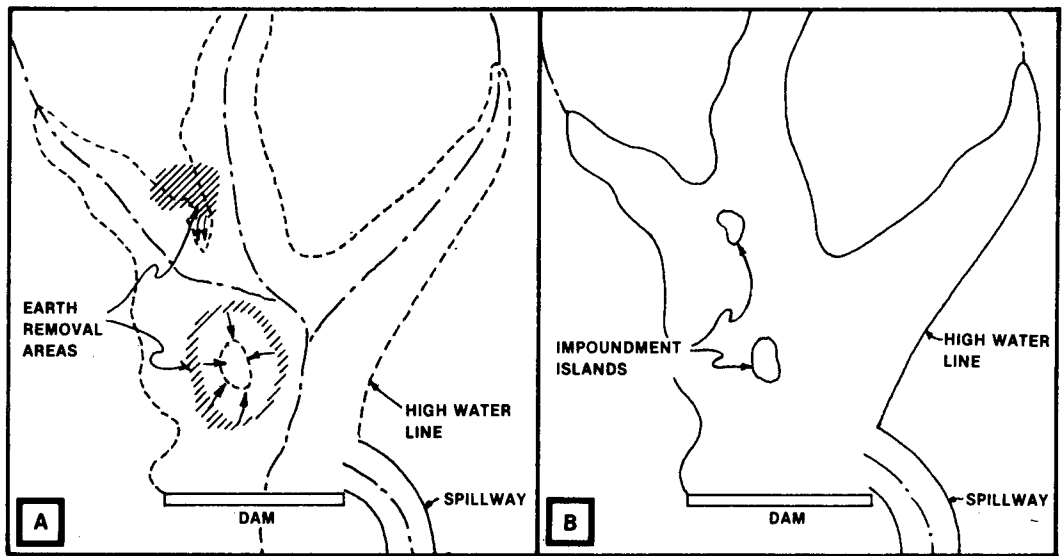

Figure 3.3-8. Schematic showing (A) possible areas of earth removal and (B) areas of placement to create postimpoundment islands (after Jones 1975).

Top soils should comprise the upper soils on the island, and reseeding with native grass species and low-growing legumes is recommended. In general, woody growth should be avoided because brushy areas that would develop are not desirable for waterfowl use. While establishing vegetation, hay or other suitable material should be spread on the surface of the island to encourage plant growth and to aid in stabilizing the island against wind and wave action (see Section 3.2.1, Overburden and Soil Handling; Section 3.3.1.c, Seeding; and Section 3.3.1.f, Cover Crops/Preparatory Crops).

MAINTENANCE AND MANAGEMENT

If properly designed, the type of island discussed in this section will be relatively maintenance free. Eventually, however, woody vegetation will invade the island and begin to grow. Since plants of this type are undesirable for waterfowl habitat, they should be removed, preferably by hand-thinning to reduce disturbance to other vegetation (see Section 3.3.1.j, Pest Control).

LABOR/MATERIALS

Small islands can be created with a few hours of equipment time (~ 2 hours/island). Draglines (0.38 to 0.57 m³ capacity [0.5 to 0.75 yd³]), scrapers, and bulldozers are among the types of equipment that can be used (Figure 3.3-9). An advantage of the use of heavy equipment is that compaction, resulting from operation of the machinery, will result in a more stable, erosion-resistant island.

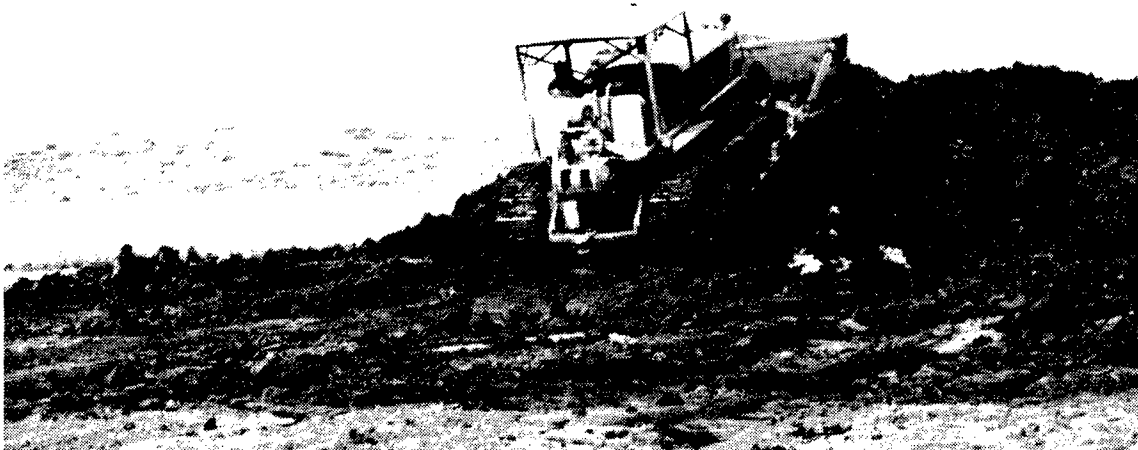

Figure 3.3-9. Earthen-mound islands can easily be constructed with a bulldozer during impoundment construction (Jones 1975).

SOURCES OF INFORMATION

- o State Regulatory Authority
- o Office of Surface Mining
- o U.S. Fish and Wildlife Service
- o U.S. Bureau of Land Management
- o U.S. Soil Conservation Service
- o State Game and Fish Agency

For addresses, see Appendix A.

References Cited:

- Hook, D. L. Production and habitat use by Canada geese at Freezeout Lake, Montana. M.S. Thesis, Montana State Univ.; 1973. 53 p.
- Keith, L. B. A study of waterfowl ecology on impoundments in southeastern Alberta. Wildl. Mono. No. 6. The Wildlife Society; 1961.
- Jones, J. D. Waterfowl nesting island development. Technical note 260; 1975. 17 p. (Available from Bureau of Land Management, Denver, CO.)
- McCarthy, J. J. Response of nesting Canada geese (Branta canadensis) to islands in stockdams in northcentral Montana. M.S. Thesis, Montana State University, Bozeman; 1973. 34 p.

Additional References:

- Hammond, M. C.; Mann, G. E. Waterfowl nesting islands. J. Wildl. Mgmt. 20(4):345-352; 1956.

e. Creating impoundments for fish.

PURPOSE

Impoundments supporting fish populations add complexity to the food web, enrich local wildlife diversity, and provide water for wildlife and livestock. Ponds further provide recreational opportunities. Most State regulatory authorities encourage the retention of such impoundments as enhancement features, provided water rights, long-term water quality, and other similar regulatory requirements are met (S. Tessman, Wyoming Department of Environmental Quality, pers. comm.; E. Englerth, North Dakota Reclamation Division, pers. comm.).

DEVELOPMENT

Pre-Construction Considerations

While ponds supporting a fish population offer a potential habitat improvement because of increased diversity, there are several constraints inherently imposed by the characteristics associated with reclaimed coal lands in the semiarid Powder River-Fort Union Coal Region. These constraints are the availability of a permanent water supply and acceptable water quality. Thus, it is difficult to establish a viable fishery in this region. Furthermore, "building a dam, impounding water, and stocking with fingerling fish does not assure satisfactory fish production" or even fish survival (Marriage and Davison 1971). Ponds supporting fish must be managed to some degree at least for the first few years. Therefore, when considering if the development of such a resource is feasible, the landowner or land management agency should also evaluate the level of postconstruction management required.

The following is a sequence of potential problems to consider before constructing an impoundment for fish:

- o Permanent water and adequate water quality are essential to fish production. Site selection, soil suitability, and a variety of other considerations are discussed under "Supplementary Water Resources" (Section 3.3.2.b). Water quality characteristics as they relate to fish species suitable for stocking are discussed in "Stocking Impoundments with Fish" (Section 3.3.2.f). The Soil Conservation Service (SCS 1971) states that ponds from 0.1 ha (0.25 acre) to several hectares can be managed for good fish production and that ponds greater than 0.8 ha (2 acres) are not as difficult to manage as smaller ones. However, Marriage and Davison (1971) contend that ponds less than 0.4 surface ha (1 acre) will not support enough fish, without supplementary feeding, to furnish much food or sport. Whatever size pond is constructed, it should be planned for the average annual runoff expected: 12 to 32 ha (30 to 80 acres)/acre foot of pond storage are generally required for this region (USDA 1971). Recommended minimum water depths in the ponds are 3 to 3.7 m (10 to 12 ft) (SCS 1971). At least one-fourth of the pond's area must be this deep to provide adequate fish habitat during all seasons

(USDA 1971), although deep areas are generally less productive than shallower areas. Deeper ponds should be excavated to guard against the ponds drying up following successive drought years. Final cut lakes and ponds (see Section 3.3.2.a, Final Cut Lakes as Permanent Impoundments) supplied groundwater by aquifers would probably require considerably less surface drainage area, depending upon flow rates from the aquifer.

- o Water quality is much more critical to fish than to terrestrial wildlife. The following parameters substantially influence fish production: water temperature; dissolved oxygen; pH; turbidity; nutrient levels (NO_3 , PO_4 , SO_4); concentration of metals; and permanent toxic materials (i.e., pesticides, hydrocarbons) (selected references on this subject are listed under Additional References at the end of this section). Prior to impoundment construction, an assessment of anticipated year-round water characteristics should be conducted and compared with the tolerance limits of fishes selected.
- o Even if the above problems are solved, it takes a relatively long time for a pond to evolve to where it can support a perennial fish population. It may take several years for adequate water to be impounded. Once the impoundment is full, 2 to 5 years are required until aquatic plants are well established (Bue et al. 1964). It may take even longer for adequate numbers of plankton and benthic fauna to be produced which serve as food for fishes. Minnows (Cyprinidae) or other nongame fish could be stocked to provide forage for piscivorous game species. In general, natural waters have low or moderate fertility. Good fish production usually necessitates the addition of commercial fertilizer which increases the growth of microscopic plants supporting the entire food chain. Fertilizer typically decreases the amount of time required before a pond can support a fish population and increases the number and size of fish a pond can produce.

Many habitat improvement programs are conducted by State game and fish agencies in conjunction with private groups. The State game and fish agency may actually help build the reservoir, supply submerged artificial breeding structures, and stock the impoundment in exchange for public access and use as a fishing area. While the impoundment is developing into a habitat supporting a self-sustaining fish population, the landowner might consider annual stocking with State-reared hatchery fish for the public. Such programs have not yet been conducted on surface mined lands; however, they would be beneficial both to the State and mine operator if the program could be worked out with the regulatory authority.

State laws on water storage and water rights vary greatly. Consult with the State engineer or water authority prior to construction.

Design Features

As stated in the previous sections, the State regulatory authority must be consulted prior to any impoundment construction. Many of the design

features and regulatory specifications for fish impoundments have been previously addressed either in this or the "Supplementary Water Resources" (Section 3.3.2.b, Specific features reviewed by the SCS (1971) and Marriage and Davison (1971) relevant to wildlife use are as follows:

- o Pond size: At least 0.4 ha (1 acre) if no supplemental feeding is intended.
- o Pond depth: A minimum depth of at least 3 to 3.7 m (10 to 12 ft) over one-fourth of the pond's area.
- o Drainage area: 12 to 32 ha (30 to 80 acres) per acre foot of water impounded in the Powder River-Fort Union Coal Region (e.g., for a 0.4-ha [1-acre] pond with an average depth of 2.1 m [7 ft], 85 to 227 ha [210 to 560 acres] are required to provide sufficient water if the pond is filled only by runoff).

Ponds designed exclusively for fish and fishing should have at least some shores which slope as abruptly as possible to a 1-m (3-ft) depth. This makes fishing easier, discourages growth of emergent aquatics and pond weeds (potentially interfering with fishing and fish production), and decreases the number of fish lost to wading birds (USDA 1971). The steep slope also may provide shelter for fish from high winds and may act as a sink in which the density of benthic organisms increases.

In ponds intended primarily for fishing, trees, stumps, shrubs, cattails, and debris should be removed from the pond site; however, this vegetation provides important habitat diversity for many wildlife species. The disturbed slopes of newly created ponds should be seeded with sod-forming grasses or woody plants (depending upon management objectives) to stabilize soil and reduce erosion and silting. Managers should avoid planting willows or deciduous trees within 9 m (30 ft) of a pond designed exclusively for fishing. These trees may interfere with fishing and their decomposing leaves deposited in the pond utilize valuable oxygen. Additional shoreline protection to minimize the effects of wave action, trampling by livestock, and other sources of damage may include berms, booms, riprap, or fencing. These methods are discussed in detail in SCS (1971).

Many of the figures and data given in this section apply to a broad geographical area and are generalized. For more detailed and site-specific design specifications, consult with local engineers and State authorities.

Engineering Considerations

As discussed in preceding sections, ponds can be excavated with bulldozers, scrapers, land planes, and/or draglines. Detailed construction procedures and engineering specifications are discussed in Agriculture Handbook No. 387 (SCS 1971), which should be consulted before construction activities begin.

MAINTENANCE

Impoundment maintenance must be carried out as required by the State regulatory authority.

LABOR/MATERIALS

The number of man-hours required obviously depends upon the size, specifications, and site of the impoundment. Construction can be accomplished with the heavy equipment normally used during mining and/or reclamation activities. Costs and labor are discussed under Supplementary Water Resources, Section 3.3.2.b. Many operators simply convert sediment control ponds to permanent impoundments. In these cases, most costs are absorbed as part of normal mine operations, and the only additional cost is that of cleaning the impoundments and converting them.

At the North Antelope Mine, Peabody Coal Company proposes to leave the final pit as a permanent impoundment (S. Tessman, Wyoming Department of Environmental Quality, pers. comm.). In this case, the cost of leaving the pit as an impoundment will probably be less costly than recontouring and revegetating.

SOURCES OF INFORMATION

- o State Regulatory Authority
- o Office of Surface Mining
- o U.S. Fish and Wildlife Service
- o U.S. Bureau of Land Management
- o U.S. Soil Conservation Service
- o State Game and Fish Agencies

For addresses, see Appendix A.

References Cited:

- Bue, I. G.; Uhlig, H. G.; Smith, D. J. Stock ponds and dug-outs. Linduska, J. P., ed. Waterfowl tomorrow; 1964. 770 p. (Available from the U.S. Government Printing Office, Washington, D.C.)
- Marriage, L. D.; Davison, V. E. Fish ponds--construction and management. Teague, R. D., ed. A manual of wildlife conservation. Washington, DC.: The Wildlife Society; 1971.
- Soil Conservation Service. Ponds for water supply and recreation. Agricultural Handbook No. 387; 1971.
- U.S. Department of Agriculture. Trout ponds for recreation. Farmers' Bull. No. 2249; 1971. 13 p. (Available from the U.S. Government Printing Office, Washington, DC.)

Additional References:

- Baxter, G. T.; Simon, J. R. Wyoming fishes. Bull. No. 4, Wyoming Game and Fish Dep., Cheyenne; 1970. 168 p.
- Burnham, B. L.; Peterka, J. J. Effects of saline water from North Dakota lakes on the survival of fathead minnows (Pimephales promelas) embryos and sac fry. J. Fish. Res. Board Can. 32:809-812; 1975.
- Chipman, R. K. Studies of tolerance of certain freshwater fishes to brine water from oil wells. Ecology 40:229-302; 1959.
- Everhart, W. H.; May, B. E. Effects of chemical variations in aquatic environments. Vol. I. Biota and chemistry of Piceance Creek. Ecol. Res. Ser. No. EPA-R3-73-011a, Environmental Protection Agency, Washington, D.C.; 1973. 117 p.
- Foster, M. A. Ionic and osmotic regulation in three species of Cottus (Cottidae, teleost). Comp. Biochem. Physiol. 30:751-759; 1969.
- Goettl, J. P., and Edde, J. W. Environmental effects of western coal surface mining. Part I - The fishes of Trout Creek, Colorado. Ecol. Res. Ser., Office of Research and Development, U.S. Environmental Protection Agency, Duluth, MN. (In Prep.)
- Grande, M. Effect of copper and zinc on salmonid fishes. Proc. 3rd Int. Conf. Water Pollut. Res. Munich, 1966. 1:96-111; 1967.
- McCormick, J. H.; Hokanson, E. F.; Jones, B. R. Effects of temperature on growth and survival of young brook trout, Salvelinus fontinalis. J. Fish. Res. Board Can. 29(8):1107-1112; 1972.
- McKim, J. M.; Christensen, G. M.; Tucker, J. H.; Lewis, M. J. Effects of pollution on freshwater fish. J. Water Pollut. Control Fed. 45(6):1370-1407; 1973.
- Peterka, J. J. Effects of saline waters upon survival of fish eggs and larvae and upon the ecology of the fathead minnow in North Dakota. PB-223 017, Natl. Tech. Inf. Serv., Springfield, VA 22161; 1972.

f. Stocking impoundments with fish.

PURPOSE

Impoundments in the Powder River-Fort Union Coal Region are stocked with fish to:

- o establish fish populations where there formerly were none;
- o increase local wildlife diversity;
- o enhance a preexisting population; and
- o introduce a species more desirable for recreation.

Ponds also provide valuable water for wildlife and may allow fishing, boating, and swimming while aesthetically enhancing the landscape (Marriage and Davison 1971).

DEVELOPMENT

Fish production is affected by water temperature, average annual water depth, dissolved oxygen, pH, turbidity, nutrient levels, food supply, concentration of metals, and the presence of toxic materials. Each species has a range of tolerance for each parameter. Therefore, it is essential that prior to stocking, water quality parameters be determined so appropriate fishes can be selected. For example, while the warm temperatures characteristic of most ponds and small impoundments in the northern and western segments of the Powder River-Fort Union Coal Region are generally unsuitable for perennial populations of trout and other cold-water species, trout may thrive in the colder higher altitude ponds in the southwest corner of the region. The analyses required to evaluate water quality and the interpretation of the results can be arranged through Soil Conservation Service conservationists, county agents, private consultants, and Federal or State fishery biologists.

Ponds should be stocked only after they are judged suitable for sustaining a perennial population. Impoundment design specifications required to sustain a perennial fishery are discussed under "Creating Impoundments for Fish" (Section 3.3.2.c) and "Supplementary Water Resources" (Section 3.3.2.b). The sunfish, minnows, catfish, and trout species which are most suitable for stocking in the warm- and cold-water ponds of this region are generally stocked as fry or fingerlings, although some catchable size can be maintained by stocking (Butler and Borgeson 1966). Ponds should be stocked with the proper species and number of individuals according to the size of the pond, its food supply, water characteristics, and the intended level of management (Dillon et al. 1971).

The stocking rate for a pond is related to its surface area, the amount of food available to the fish or fishes stocked, and the size of fish desired (Marriage and Davison 1971; Marriage et al. 1971). The surface area determines the amount of sunlight available for the photosynthetic production of food (Marriage and Davison 1971). Recommended stocking rates in warm-water ponds of average fertility are 125 bass and 1,235 bluegills per surface hectare (50 and 500 per surface acre, respectively (Dillon et al. 1971). In cold-water

ponds with average food supplies, spring stocking a 0.4-ha (1-acre) pond with 500, 5- to 10-cm (2- to 4-inch) trout fingerlings will yield 18- or 20-cm (7- or 8-inch) trout the first year. Stocking 250 fingerlings in the fall should produce 25-cm (10-inch) trout the first year (Marriage et al. 1971). Under normal fishing pressure, 10- to 13-cm (4- to 5-inch) trout fingerlings are restocked every two years to maintain the catchable population since trout generally do not reproduce in impoundments. For more specific stocking rates of other species and stocking combinations under different fertility levels, see Dillon et al. (1971) and Grizzell et al. (1975), or consult with fishery biologists from Federal or State game and fish agencies or the local SCS office.

Since summer water temperatures of most lower elevation ponds in the Powder River-Fort Union Coal Region reach 27°C (80°F) to 32°C (80° to 90°F) or higher (measured 15.2 cm [6 in] below the surface), they must be stocked with fish species adapted to this thermal environment. Species such as largemouth bass, bluegill and other sunfish ("bream"), channel catfish, and black bullhead are suitable for warm-water ponds where summer temperatures exceed 21°C (70°F) for four or more months per year (Baxter and Simon 1970; Dillon et al. 1971; Marriage and Davison 1971; Grizzell et al. 1975; Woodling 1980).

Trout can live in ponds containing water between 1° and 24°C (33° and 75°F), but grow most rapidly in water between 10° and 18°C (50° and 65°F). Trout die if the water temperature reaches 30°C (86°F). Rainbow trout are most frequently stocked in ponds because they thrive under a wide range of conditions and are widely available from hatcheries. Brook trout are also suitable for stocking and are often stocked with rainbows. Brown and cut-throat trout are not recommended for stocking in ponds (Marriage et al. 1971).

Fish may be obtained from Federal (U.S. Fish and Wildlife Service), State (game and fish agencies), or commercial hatcheries or from fish farmers. However, prior to stocking, the State game and fish agency should be contacted for approval of any permit that may be required. Often an agreement can be reached between the landowner and the fish and wildlife agency whereby the landowner's impoundment is stocked with fish in exchange for public access and use. In this case, Federal or State personnel transport and stock the pond with suitable fishes. Most likely, whether fish are obtained from a Federal, State, or private hatchery, the hatchery can arrange delivery in an insulated tank truck with mechanical refrigeration, oxygen, and a fish pump. For more information on the transportation of live fish and the factors influencing this, see Johnson (1979).

MAINTENANCE AND MANAGEMENT

The key to maintaining a viable fish population is the perpetuation of a suitable environment, specifically adequate water quality. However, maintenance of such water characteristics as fertility, turbidity, acidity, dissolved oxygen, and temperature in a range tolerated by fish, and fish management practices, such as supplemental feeding, fencing from livestock, pond depth, and fishing, are too complex to discuss in detail here. For more information on these factors and practices, see Marriage and Davison (1971),

Marriage et al. (1971), Dillon et al. (1971), Grizzell et al. (1975), Martin (1978), Johnson (1979), and Boyd (1980), or contact your local SCS office.

LABOR AND MATERIALS

Without assistance from Federal or State agencies, fish stocking costs are a composite of production, transportation, and personnel costs. The costs of raising fish at hatcheries varies between \$1.65 and \$2.73 per kg (\$0.75 and \$1.24 per lb) of fish released (1977 dollars) (Bell 1973; Nelson et al. 1978). Cost per kg to the landowner will be higher. Transportation costs vary with the type of equipment used, the transport distance, and the accessibility of the release site. Operating costs for a modern insulated tank truck with mechanical refrigeration and oxygen are around \$1.86 per km (\$3.00 per mi) (after Bell 1973, adjusted to 1981 dollars). Once at the release site, stocking should take approximately an hour while the fish are acclimated to the water characteristics of the pond (see Marriage et al. 1971).

SOURCES OF INFORMATION

- o State Regulatory Authority
- o Office of Surface Mining
- o U.S. Fish and Wildlife Service
- o U.S. Soil Conservation Service
- o State Game and Fish Agencies

For addresses, see Appendix A.

References Cited:

- Baxter, G. T.; Simon, J. R. Wyoming fishes. Wyoming Game and Fish Department Bull. No. 4. Cheyenne; 1970. 168 p.
- Bell, M. C. Fisheries handbook of engineering requirements and biological criteria. Fisheries Engineering Research Program, U.S. Army Corps of Engineers; 1973.
- Boyd, C. E. Water quality in catfish ponds. Aquaculture 6(6):39; 1980.
- Butler, R. L.; Borgeson, D. P. "Catchable" trout fisheries. Calhoun, A., ed. Inland fisheries management. California Department of Fish and Game; 1966.
- Dillon, O. W.; Neely, W. W.; Davison, V. E.; Compton, L. V. Warm-water fish-ponds. USDA Soil Conservation Service, Farmers' Bull. No. 2250. U.S. Govt. Printing Office, Washington, D.C.; 1971. 14 p.*
- Grizzell, R. A.; Dillon, O. W.; Sullivan, E. G.; Compton, L. V. Catfish farming. USDA Soil Conservation Service, Farmers' Bull. No. 2260. U.S. Govt. Printing Office, Washington, D.C.; 1975. 21 p.*

Johnson, S. K. Transport of live fish. *Aquaculture* 5(6):20-24; 1979.

Marriage, L. D.; Davison, V. E. Fish ponds--construction and management. Teague, R. D., ed. *A manual of wildlife conservation*. The Wildlife Society, Washington, D.C.; 1971. 100-102 pp.

Marriage, L. D.; Borell, A. E.; Scheffer, P. M. Trout ponds for recreation. USDA Soil Conservation Service, Farmers' Bull. No. 2249. U.S. Govt. Printing Office, Washington, D.C.; 1971. 13 p.*

Martin, M. Fish farmer must know what to do when turbidity becomes a problem in his ponds. *The Commercial Fish Farmer* 4(5):19-21; 1978.

Nelson, R. W.; Horak, G. C.; Olson, J. E. Western reservoir and stream habitat improvements handbook. U.S. Fish and Wildlife Service, FWS/OBS-78/56; 1978.

Woodling, J. Game fish of Colorado: an identification guide for sport fish commonly caught in Colorado. Denver: Colorado Division of Wildlife; 1980. 40 p.

*Publications often available from local Soil Conservation Service and County Agent offices.

g. Streambank protection-gabion matting and riprap.

PURPOSE

The purpose of streambank protection is to:

- o prevent bank erosion and subsequent sedimentation
- o prevent the destruction of riparian (streambank) habitat.

Two common methods used to stabilize streambanks until vegetation is re-established are gabion mats and riprap. Problems with these structures are that they provide poor hiding places for fish and tend to increase water velocity. However, bank erosion can be a very serious problem, and these structures should be used if revegetation or other methods to protect the bank are not feasible or are unsuccessful.

DEVELOPMENT

The basic elements of a gabion structure are rectangular wire-mesh cages and rock. Standard gabion mat sizes are given below as:

Dimensions in meters	Approximate equivalents in feet	No. of diaphragms (Partitions)	Capacity	
			Cubic meters	Cubic yards
2 x 1 x 1	6' 6" x 3' 3" x 3' 3"	1	2	2.616
3 x 1 x 1	9' 9" x 3' 3" x 3' 3"	2	3	3.924
4 x 1 x 1	13' 1" x 3' 3" x 3' 3"	3	4	5.232
2 x 1 x .5	6' 6" x 3' 3" x 1' 8"	1	1	1.308
3 x 1 x .5	9' 9" x 3' 3" x 1' 8"	2	1.5	1.962
4 x 1 x .5	13' 1" x 3' 3" x 1' 8"	3	2	2.616
2 x 1 x .3	6' 6" x 3' 3" x 1'	1	0.6	0.785
3 x 1 x .3	9' 9" x 3' 3" x 1'	2	0.9	1.177
4 x 1 x .3	13' 1" x 3' 3" x 1'	3	1.2	1.570

Fractional size mats may be placed along the slope of a streambank (Figures 3.3-10 and 3.3-11) to effectively prevent erosion. It is recommended that the wire baskets used to build the mats be assembled in place, formed, and stretched out prior to filling with rock. Where more than one mat needs tying together, it is easier to do prior to filling with rock. Hand placement of rock in the basket is suggested over machine fill since sagging is less likely to occur in hand-filled baskets. The top of the basket or lid should be closed and fastened on the downstream side to prevent debris from ripping it off.

Riprap may be less expensive to use than gabion matting. Large rocks may be piled along the bank to help prevent its eroding away (Figure 3.3-12). The rock should be large enough to prevent silting of the intervening spaces. These intervening spaces may actually provide fish habitat. Use of riprap is common along roads and specifications should comply with road building codes.

MAINTENANCE AND MANAGEMENT

These techniques of erosion control are temporary and should not be expected to replace the need for revegetation of a streambank. In cases where bank stabilization is a serious problem, however, these techniques can provide the protection to allow for reestablishing vegetative cover. Depending on the site, stream size, and degree of erosion, the need for replacement of gabions or riprap will vary.

LABOR/MATERIALS

Cost, man-hours, equipment needs, and materials will vary with site specific characteristics. Use of riprap is cheaper than gabions, but depends on the availability of the proper sized stone. Hauling stone long distances can significantly affect cost. Gabions require the use of wire mesh and therefore require the added cost of construction labor. If the rocks are placed in the wire cages by hand (as recommended), then labor cost will be incurred there also.

Generally, prices of stone riprap average \$24.00/0.77 m³ (1 yd³) dumped. Stone filler for gabion mats runs approximately \$24.00/0.77 m³ (1 yd³) but can range from \$14.00 to \$45.00/0.77 m³ (1 yd³). Wire mesh for constructing gabions varies in price based on mesh size and wire gauge but can range from \$4.64 to \$15.47 per linear meter (1.09 yd).

SOURCES OF INFORMATION

More information on the use and construction of gabions and riprap may be obtained from:

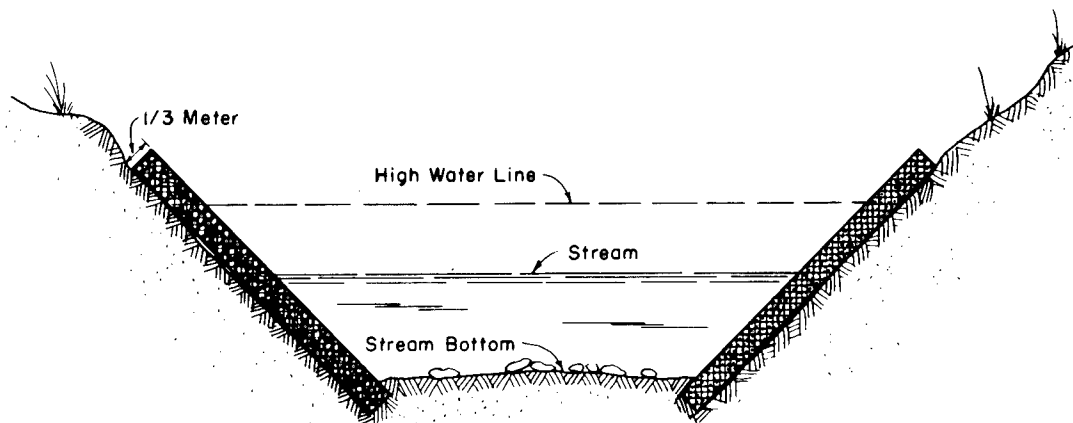

Figure 3.3-10. Stream cross section showing the use of gabion mats on a sloping streambank (from Nelson et al. 1978).



Figure 3.3-11. Placement of stone gabion to protect a streambank (from U.S. Forest Service 1969).



Figure 3.3-12. Use of riprap to protect a streambank from erosion (from U.S. Environmental Protection Agency 1976).

- o State Regulatory Authority
- o Office of Surface Mining
- o State Highway Department
- o U.S. Forest Service
- o U.S. Army Corps of Engineers
- o U.S. Soil Conservation Service
- o State Game and Fish Agencies
- o U.S. Fish and Wildlife Service

For addresses, see Appendix A.

References Cited:

- Nelson, R. W.; Horak, G. C.; Olson, J. E. Western reservoir and stream habitat improvements handbook. U.S. Fish and Wildlife Service, FWS/OBS-78/56; 1978.
- U.S. Forest Service. Wildlife habitat improvement handbook. USDA Forest Service, FSH 2609.11; 1969.
- U.S. Environmental Protection Agency. Erosion and sediment control-surface mining in the Eastern U.S. Technology Transfer, EPA-625/3-76-006; 1976.

Additional References:

- Keown, M. P.; Oswalt, N. R.; Perry, E. B.; Dardeau, E. A., Jr. Literature survey and preliminary evaluation of streambank protection methods. U.S. Army Engineer Waterways Experiment Station, Hydraulics Laboratory, Mobility and Environmental Systems Laboratory, Soils and Pavement Laboratory, Technical Report H-77-9; May 1977.

3.3.3 Wildlife Habitat Improvement and Development

a. Creating topographic features.

PURPOSE

The Powder River-Fort Union Coal Region is primarily flat to rolling terrain. In such areas, various approaches can be employed to increase the habitat diversity. These range from a minimal effort to maintain existing topographic features to large scale habitat creation. The overall purpose of each of these projects would be to create an environment that could better support a greater diversity of organisms.

Because strip mine reclamation has primarily focused on recontouring of the land to that original topography, almost no information is available concerning structuring the land with wildlife habitat as the focus. The enhancement measures in this chapter consider general ecological requirements of wildlife in the Powder River-Fort Union Coal Region. As stated in previous sections, all topographic features on coal mined lands will have to be approved by the State regulatory authority.

DEVELOPMENT

Dry stream beds or gullies can provide seasonal wetlands, as well as corridors for wildlife movement. These features should be maintained whenever possible. Planting of hedgerows along these features can improve and diversify wildlife habitat for escape, refuge, or travel lanes.

Rock piles are another feature which can be used to create a more diverse habitat. Rock piles are useful to small mammals and rodents which nest among the rocks. Construction of the rock piles is discussed in Section 3.3.3.d, Rock Piles.

For larger wildlife species, such as antelope, creation of land forms will require greater efforts. The features that the land form takes will vary according to the amount of overburden available, size of the pit left after coal removal, rainfall, etc. Richard Kerr (Bureau of Land Management, Denver), in an unpublished manuscript, described some options that are available. These are presented below, and may be used by the operator if the State regulatory authority finds that they fall within the approximate original contour requirements.

One experimental technique is to contour overburden or spoil materials to a form reminiscent of what Kerr calls a "poppy seed roll" (Figure 3.3-13). The advantages of such a form over uniform or flat areas is that it allows different sun exposures, provides various air or wind flows, creates a variety of plant habitats, and allows a varied elevation and topographic variety for viewing, hiding, and resting. Implementation of these forms will probably require a variance from the State regulatory authority because it does not conform to the approximate original contour concept.



Figure 3.3-13. Contouring to create wildlife habitat (after Kerr, no date).

Varying sun exposures create different conditions of humidity, air, and soil temperatures. Mule deer will congregate on the warm dry areas on south facing slopes in winter. The windbreak effect of these forms is also an important feature (Figure 3.3-14). Antelope will escape blizzard-like conditions on the lee sides of the slopes. Deer will also congregate on the upper half of the south facing slope in winter.

To enhance the windbreak effect, vegetation can be planted to provide shelter and habitat (for a discussion of windbreaks, see Section 3.3.3.c, Creating Wind and Snowbreaks for Winter Wildlife Protection). Timber growth may be possible on north facing slopes. This would provide for different small mammal and rodent habitats and increase hunting and roosting areas for raptors. A rolling hill with a downward view may enhance antelope fawning while escape is also offered to game animals from one side of a hill to the other.

The Thunder Basin Coal Co. in Wright, WY, has created promontories for eagles by building hills approximately 6 to 7.5 m (20 to 25 ft) high. On one corner of the hill is an even more elevated portion, approximately 9 m by 12 m (30 ft by 40 ft), littered with rocks. The hill has been situated so that it overlooks a valley providing a viewing area for eagles.



Figure 3.3-14. Windbreak effect of land contouring (after Kerr, no date).

Highwalls also offer an opportunity to create important wildlife habitat. George Larson (Thunder Basin Coal Co, pers. comm.) has seen eagles soaring above the highwall on the Thunder Basin Coal Co. property in North Dakota. The highwall can also provide nesting holes for raptors and cliffs for roosting bats and nesting swifts and swallows. Kerr has suggested building artificial nesting cavities by blasting or digging a flat bottomed hole 1.8 to 2.4 m (6 to 8 ft) wide, 1.8 m (6 ft) high, and 1.2 to 1.5 m (4 to 5 ft) deep. The nest locations should be about three quarters of the way up the wall and at least 1.8 m (6 ft) from the top. Ledges may also be constructed.

Highwalls, however, should not cater only to the habitat requirements of one species or group of species (e.g., golden eagles or raptors). RECLAIMED HIGHWALLS SHOULD SIMULATE A RIMROCK HABITAT. This habitat is extremely important to a wide variety of wildlife species.

They [rimrocks] serve as nesting and denning sites for many mammals, birds, and reptiles. Skunks, rabbits, bobcats, fox, pack rats, raccoons, and many species of mice and voles live in or around rimrocks for all or part of the year. Several species of hawks and owls, as well as a variety of smaller birds, nest in these areas. A number of reptiles utilize rimrocks as refuge and denning sites.

In many regions rimrocks are one of the only sources of cover during winter storms. They serve as windbreaks which are sought out by game animals and birds. In addition, because of the windbreak function these areas serve, they often accumulate moisture in the form of snow drifts. This increased moisture, coupled with variations in soil conditions in rimrock areas, results in the presence of many plants such as currant, bitterbrush, mountainmahogany, and others. These shrubs are important as a winter food source for a great many forms of wildlife.

A loss of a rimrock area and its associated vegetation can eliminate or reduce not only the resident wildlife but also wildlife from vast surrounding plains areas. For these reasons it is extremely important that rimrocks be preserved [and restored] where possible. [Wyoming Game and Fish Department 1976].

Reclaimed highwalls should include talus slopes (rock piles) at their bases, ledges, holes, an access corridor from bottom to top, vegetation to stabilize the slope and provide forage and cover, and shrub patches located around the base and throughout the area. A potential landform design is illustrated in Figure 3.3-15.

In the past, Federal and State regulations have required the elimination of highwalls during the reclamation process. The standard procedure for reclaiming highwalls has been to grade material over the highwall to an acceptable slope of at least 2:1, eliminating the wall. The Seminoe No. 1 Mine (Arch Mineral Corp., Hanna, WY) has requested a variance from the Wyoming Department of Environmental Quality and the Office of Surface Mining to leave a reduced highwall for the purposes of protecting a currently active golden eagle nest and providing additional raptor nesting and roosting habitat. A pair of eagles successfully produced young on the highwall for three years. This variance received support from the U.S. Fish and Wildlife Service, Bureau of Land Management, and Wyoming Game and Fish Department. The highwall modification would leave a 305-m (1,000-ft) section of a once 5,639-m (18,500-ft) highwall and reduce the present height to about 12 m (40 ft) (Arch Minerals Corp. 1982). Spoil will be banked against the highwall until at least 1.2 m (4 ft) of material has covered the last upper coal bed exposed. All acid-forming or toxic material, which lie in the pit, will be covered with at least 1.2 m of suitable material. The surface of the graded spoil will be roughened to facilitate water infiltration and retention. Shrubs will be broadcast seeded and shrub transplants and rockpiles will be placed at the base of the highwall, as well as on the regraded slope opposite.

A combination of the highwall and "poppy seed roll" provides another option (Figure 3.3-15). Allowing the area between the hills to fill with water further increases the habitat diversity of the area. Any form of water hole will provide an important habitat in dry, semiarid regions. Even if filled only during part of the year, the water holes will provide nesting or resting areas for many species of birds (see Section 3.3.2.c, Creating Impoundments for Waterfowl).

MAINTENANCE AND MANAGEMENT

For most of these features, maintenance would be restricted to ensuring vegetation establishment and slope stabilization once the structure has been completed.

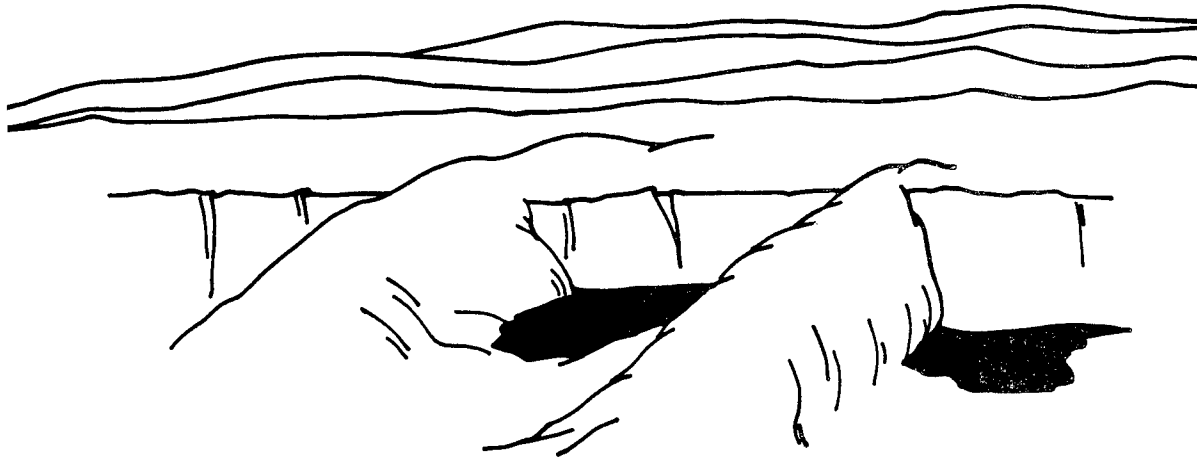

Figure 3.3-15. Contouring to create waterholes and simulate a rimrock habitat.

LABOR AND MATERIALS

Costs would be a function of engineering requirements and heavy equipment use. These costs would have to be balanced against those for reclaiming the land to its original contours.

SOURCES OF INFORMATION:

- o State Regulatory Authority
- o Office of Surface Mining
- o U.S. Fish and Wildlife Service
- o State Game and Fish Agency

For addresses, see Appendix A.

References Cited:

- Arch Minerals Corp. Permit to mine application, Seminoe No. 1 Mine. Hanna, Wyoming; 1982.
- Kerr, R. Ideas about reclaiming western mined lands for wildlife. Unpublished manuscript, Bureau of Land Management, Denver Service Center, Denver, CO.
- Wyoming Game and Fish Department. Considerations for wildlife in industrial development and reclamation. Cheyenne, WY; 1976. 65 p.

b. Planting patterns to increase wildlife diversity.

PURPOSE

The spatial arrangement of habitat requirements in a community is a key determinant of the area's value to, and use by, wildlife. Use is largely determined by the mobility of a species and the relative availability of food, water, cover, and other habitat requirements. The greater the interspersion of these habitat components, or the more patchiness or diversity that exists in the community, the more valuable the area is to wildlife, in general. For example, pronghorn distribution is restricted by late summer water availability on many ranges. Sundstrom (1968) found 95% of 12,465 pronghorn in Wyoming's Red Desert within a 4.8- to 6.4-km (3- to 4-mi) radius of a water source. Adjacent areas lacking water sources received low utilization. Utilization of adjacent ranges could be greatly improved if the habitat components (in this case, water sources) were more evenly distributed (in this case, every 4 to 5 km, 2.5 to 3 mi), or if supplementary wells were provided. Reclamation of mined coal lands, which incorporate the interspersion of vegetation types to increase habitat diversity and provide additional food and cover, potentially increase wildlife diversity. In all cases, the State regulatory authority will determine the acceptability of proposed revegetation species and the selective placement of such species.

DEVELOPMENT

"Edge" occurs where two habitat types come together, such as grasslands and shrubsteppe. A measure of total linear "edge" per unit area is a good general indicator of total (all species) wildlife production potential. Patton (1975), relating "edge" to diversity, proposed a means of measuring this diversity through an index using the circumference to area ratio of a circle (the geometric figure with the least perimeter for a given area) as the base value. He calculated that, compared to a circle of the same area, a square and a rectangle have 13 and 41% more "edge", respectively (Figure 3.3-16). Subdividing these figures into different vegetation types additionally increases the diversity index. Figure 3.3-16 shows that long narrow strips divided into different vegetation types provide the greatest diversity index value. However, PATTERNS OF VEGETATION TYPES ON RECLAIMED LANDS "MUST BE DESIGNED TO FOLLOW NATURAL TOPOGRAPHIC FEATURES (such as drainages, toe slopes, knolls, etc.) AS OPPOSED TO GEOMETRICAL" STRIPS (Yoakum et al. 1980). In most situations, this will actually further increase "edge." The goal for spatially arranging vegetation types is to maximize the interspersion of a variety of wildlife habitat requirements relative to their mobility (as measured by the home range). For example, the interspersion of habitat requirements for a deer mouse with a home range of 2 ha (5 acres) must be on a much smaller scale than for a highly mobile, far ranging golden eagle with a home range of 25,900 ha (100 mi²). (This, perhaps, unrealistically assumes the same number and proportionate area of habitat requirements for each species.)

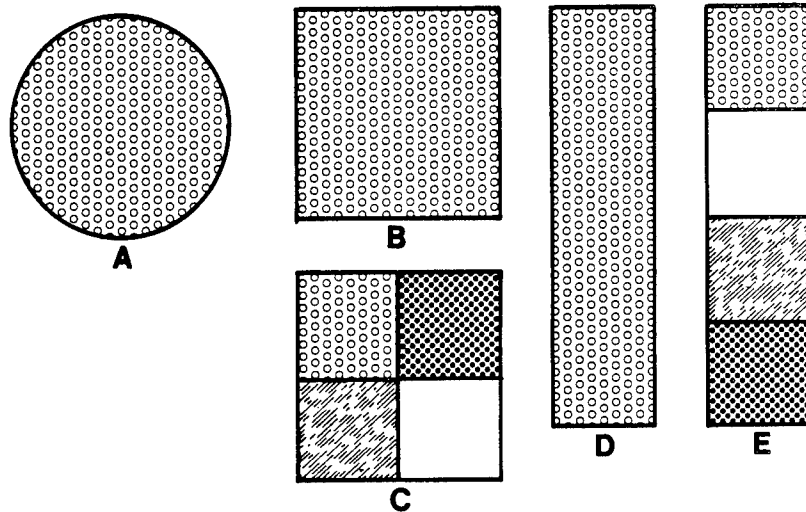

Figure 3.3-16. Comparison of diversity indices for various geometrical shapes all with an area of 0.4 ha (1 acre). A = 1.0, B = 1.13, C = 1.69, D = 1.41, E = 1.83 (Index values and figure after Patton [1975]). NOTE: The geometrical shapes used above serve only as examples to convey the concept of edge and interspersion. Patches of vegetation on reclaimed areas should have irregular shapes and vary with the topography.

Although increasing "edge" through habitat manipulation benefits the great majority of wildlife, some species will do best where diversity is lowest. Therefore, as with all environmental manipulations, the wildlife biologist must beforehand evaluate the effectiveness of the proposed alterations, and assess any potentially detrimental effects to sensitive species or species of special concern caused by the proposed practice.

What to Plant

Different types of vegetation yield different values for wildlife. They may provide food, cover, escape terrain, nesting habitat, and/or other habitat requirements. Trees and shrubs typically provide nesting habitat, cover, fawning areas, escape terrain, security, and foraging areas. Grasses and forbs generally provide food, but may also provide cover, nesting habitat, and escape terrain for smaller wildlife. A wildlife biologist can determine those habitat requirements, most needed by a single or a group of species, that can be provided through the spatial arrangement of selected vegetation types.

Once the desired life forms (trees, shrubs, grasses, or forbs) are determined, native or introduced species can be planted in a spatial arrangement best suited to the site. The land management agency and Soil Conservation

Service are good sources of information on plants adapted to a particular area. An additional source of information on suitable revegetation species is available through the Plant Information Network (PIN) (Section 3.3.1.a), a computer-based service available for public use at a minimal charge through the U.S. Fish and Wildlife Service. It provides relative importance values of food and cover for certain wildlife species or groups. For more information on this system, see "Use of the Plant Information Network (PIN) to Aid in Selection of Revegetation Plants" (Section 3.3.1.a).

Where to Plant

Microenvironmental site selection, site preparation, planting depth and soil moisture are the most important considerations leading to successful revegetation (Yoakum et al. 1980). Sites which formerly supported the species of concern offer the greatest probability for successful reestablishment.

The leeward side of hills are relatively protected areas which can be used to increase habitat diversity. Lee slopes generally have more soil moisture, potentially produce more succulent and vigorous vegetation, and have lower wind velocities. Such areas, when revegetated, provide ideal habitat for food, cover, and a variety of other wildlife requirements. At the Thunder Basin Coal Mine near Wright, WY, the broadscale planting of shrubs has been replaced by transplanting 0.4 to 0.8 ha (one to two acres) of shrub patterns on the lee side of hills (George Larson, pers. comm.).

The microclimate on north-facing slopes is generally cooler, more moist, and more shaded than other slopes, and, as such, is more conducive to the establishment of trees and shrubs, such as ponderosa pine, juniper, curlleaf mountainmahogany, antelope bitterbrush, big sagebrush, and rubber rabbitbrush. South-facing slopes, while drier during summer, have greater snow-shedding characteristics, making them important winter range and resting areas in the winter for big game.

"Odd areas" may also provide useful wildlife habitat. Such areas include eroded features in agricultural fields, bare knobs, sinkholes, blowouts, gullies, abandoned roads, railroad rights-of-way, borrow pits, hedgerows, fencerows, and areas cut off from the rest of a field by a stream, drainage ditch, or gully. Ditchbanks, when covered with grasses and legumes, provide ideal habitat for small mammals, passerines, and some game birds (Anderson 1969). During dry seasons, ditchbanks may provide escape corridors for larger wildlife. Plantings in the odd areas may include clumps of evergreens centrally located to provide cover. Shrubs, grasses, and forbs may be planted about the trees so as to intersperse the area with other wildlife requirements and provide additional habitat for small mammals and ground-nesting birds.

MAINTENANCE AND MANAGEMENT

Maintenance and management is generally restricted to the initial establishment of vegetation. Depending upon objectives, some areas may require biennial mowing to suppress woody plants. Mowing should occur only after the broods of ground-nesting birds have left the nest, generally in late summer.

LABOR/MATERIALS

Costs involved in modifying planting patterns for the benefit of wildlife include:

- o additional species to be used for reclamation; and
- o additional labor and materials costs for revegetating areas in a larger number of smaller, more diverse vegetation types rather than a single, expansive monoculture.

For more information on revegetating procedures and costs, see the appropriate practices under "Revegetation" (Section 3.3.1)

SOURCES OF INFORMATION

- o State Regulatory Authority
- o Office of Surface Mining
- o U.S. Bureau of Land Management
- o U.S. Fish and Wildlife Service
- o U.S. Forest Service
- o U.S. Soil Conservation Service
- o State Game and Fish Agencies

For addresses, see Appendix A.

References Cited:

- Anderson, W. L. Making land produce useful wildlife. USDA Farmers' Bull. No. 2035. U.S. Govt. Printing Office, Washington, D.C.; 1969. 29 p.
- Patton, D. R. A diversity index for quantifying habitat "edge." Wildl. Soc. Bull. 3:171-173; 1975.
- Sundstrom, C. Water consumption by pronghorn antelope and distribution related to water in Wyoming's Red Desert. Antelope States Workshop Proc. 3:39-46; 1968.
- Yoakum, J.; W. P. Dasmann; H. R. Sanderson; C. M. Mixon; H. S. Crawford. Habitat improvement techniques. Pages 329-403 in Schemnitz, S.D., ed. Wildlife management techniques manual. Washington, D.C.: The Wildlife Society; 1980.

Additional References:

- Ward, A. L. Multiple use of timbered areas: views of a wildlife manager specifically for elk and mule deer. Proc. Rocky Mountain Forest Industries Conf., May 7-10, Jackson, WY; 1980. 24 p.

c. Creating wind and snowbreaks for winter wildlife protection.

PURPOSE

The construction of wind and snowbreaks can be classified under the general heading of cover improvement. Specifically, breaks provide protection for both wildlife and livestock during severe weather, as well as escape refuge for wildlife. They also provide cover and food for birds. The absence of cover, its sparseness, or its poor distribution can limit the use of an area by wildlife (Yoakum and Dasmann 1971). Windbreaks and snowbreaks also help to reduce soil erosion, the drying effects of wind on soil and plants, and the abrasive action of rapidly moving soil particles on young seedlings. During the winter, windbreaks trap snow that provides moisture for plants in spring and summer.

Species selection and location of plantings on coal mined lands must be approved by the State regulatory authority.

DEVELOPMENT

When planting windbreaks to enhance wildlife habitat, there are a few generalizations that should be remembered during planning:

- o Tighter barriers are better than more porous ones. Tighter windbreaks can be assured by multirow plantings.
- o Trees and shrubs most useful for wildlife should be selected.
- o Plants selected for wildlife use should be planted in the correct location in the windbreak, generally on the leeward side. Middle or windward locations provide little use during the winter.
- o If possible, plantings should be on an east/west line. This provides wildlife loafing areas throughout the day.
- o With multirow plantings, the windward rows should provide as tight a barrier as possible to prevent snow drifting across the entire break.
- o When in doubt, plant shrubs rather than trees for wildlife; plant suckering rather than nonsuckering shrubs.
- o Plant tall trees a few rows from the shrubs to prevent overtopping or a high-wall effect.

Windbreaks should be planted at right angles to prevailing winds and should follow the contour in sloping fields, at right angles to the wind (Ferber 1969). Where damaging winds come from several directions, it is necessary to plant the windbreaks in patterns forming squares or two-direction combinations. For livestock, plantings should be in the form of an L, U, or E design and placed to protect feed and water supplies.

Windbreak designs can take several forms (Figures 3.3-17 to 3.3-19). In areas where blizzards are common, 10- to 15-row windbreaks are recommended. At a minimum, no less than five to seven rows should be planted. Shrubs are planted approximately 0.9 to 1.2 m (3 to 4 ft) apart, medium trees 1.2 to 1.8 m (6 to 8 ft), and tall trees 2.7 to 3.6 m (8 to 10 ft). In dry land areas, a 6-m (20-ft) spacing between rows should be established. Yoakum and Dasmann (1971) suggest a windbreak for each 9 to 10 ha (20 to 25 acres) in open country.

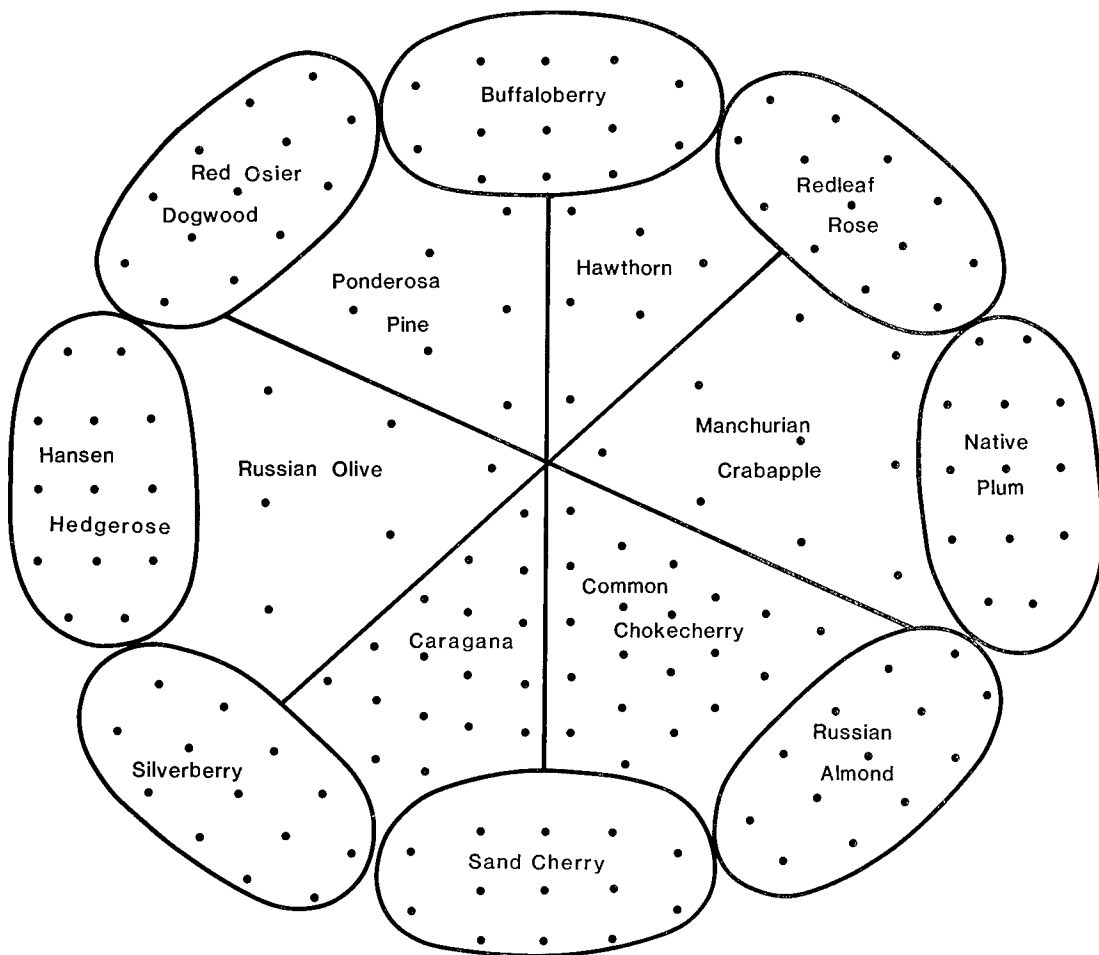

Figure 3.3-17. Suggested wildlife planting for an open area (from Heintz et al. no date).

Size: The size of the planting will depend on the area available. The number of wildlife species and individuals using the planting will increase with increasing size and diversity of the planting.

Row				
1				
2				
3	Blue spruce	Silverberry	Red osier dogwood	Rocky Mt. juniper
4				
5				
6				
7	Bur oak	American elm		Ponderosa pine
8				
9				
10				
11	Chokecherry	Hawthorn	"Midwest" crabapple	Buffaloberry
12				
	Optional Herbaceous Cover Strip (9.1 to 30.5 m 030 to 100 fto wide)			
13				
14				
15	H. hedgerose	R. almond	N. cherry	Caragana
			Sand cherry	Plum
			Juneberry	Redleaf rose
16				

Figure 3.3-18. Multirow wildlife plantings with single species planted in blocks (from Heintz et al. no date).

Example species are listed for a 16-row belt, but this planting in blocks can be applied to any width of belt. Openings of about one rod between blocks is advantageous. Blocks of single species provide more advantages to wildlife than single species rows. Let wildlife reap the benefits of a little extra planning at planting time.

- Redleaf rose(1) 1
- Buffaloberry (4) 4
- Russian olive (6) 2
- Hawthorn (12) 5
- Mixed¹ (13) 3

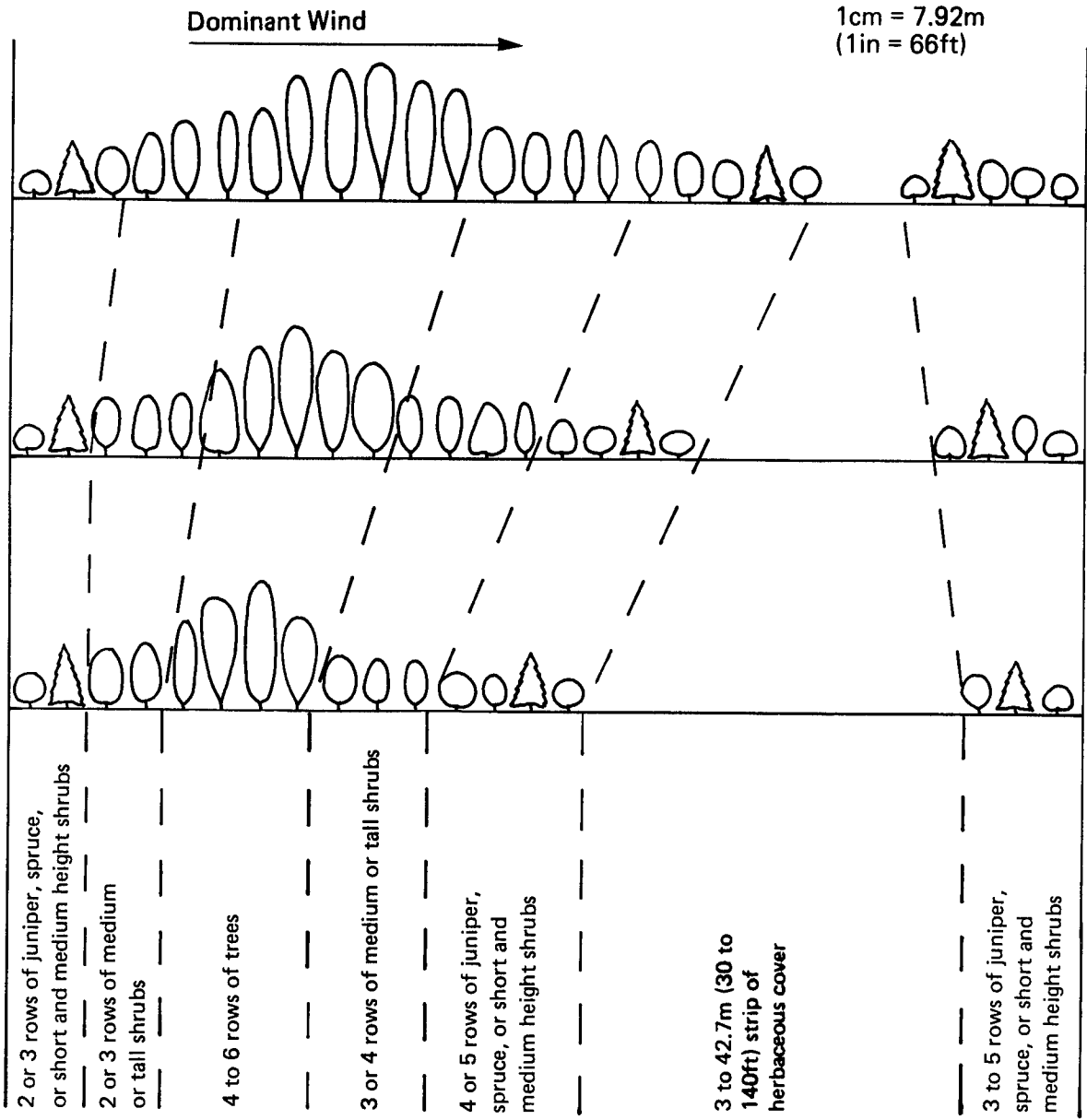

Figure 3.3-19. Suggested design for large multirow wildlife plantings (end view) (from Heintz et al. no date).

Spacing: Shrubs: 1 to 1.2 m (3 to 4 ft) by 3.7 to 4.6 m (12 to 15 ft).
 Low to medium trees: 1.8 to 1.4 m (6 to 8 ft) by 3.7 to 5.5 m (12 to 18 ft). Tall and bushy trees: 2.4 to 3.0 m (8 to 10 ft) by 3.7 to 6.1 m (12 to 20 ft). If cultivation is to take place, the size of the cultivator will dictate the width between rows.

The list below, which has been taken from the Tree Planting Handbook for the Dakotas (Heintz et al. no date), gives suggested arrangements of tree and shrub species of high value to wildlife. Other similar species may be substituted as necessary. State regulatory authorities are encouraging the use of native species in revegetation to the maximum extent possible, but some introduced species may be approved. The Tree Planting Handbook for the Dakotas and the Conservation Planting Handbook for Wyoming and Colorado (Johnson and Anderson 1980) describe plant species suitable for wildlife in the Powder River-Fort Union Coal Region. These books are available from the agricultural extension service in the representative States. The numbers on the right suggest which species should be included in a planting of the size needed. (Consult the above reports for instructions on the selection of species for various planting dimensions.) The numbers in parentheses behind the names give the relative position of that species within a planting. These parenthetical numbers should be arranged in ascending order from north to south, but may not be consecutive.

<u>Species and Location</u> ¹	<u>Index of Species to Include</u>
Redleaf rose (1) ¹	1
Silverberry (2)	12
Caragana (3)	14
Buffaloberry (4)	4
Chokecherry (5)	10
Russian olive (6)	2
Siberian elm (7)	15
American elm (8)	11
Green ash (9)	13
Boxelder (10)	6
"Midwest" crabapple (11)	7
Hawthorn (12)	5

9.1 to 30.5 m (30 to 100 ft) of herbaceous cover may be included here

Mixed ² (13)	3
Mixed ² (14)	8
Mixed ² (15)	9

¹Relative position of row in planting

²These rows should be identical so they form blocks of species when planted together. They may include Hansen hedgerose, red-osier dogwood, and fruit like Nanking cherry, sand cherry, juneberry, plum, or others.

Example: To create a five-row belt, include all species numbered 5 or less in the right column and arrange them according to the relative position number in the parenthesis behind the species name; i.e.,

Redleaf rose(1)	1
Buffaloberry (4)	4
Russian olive (6)	2
Hawthorn (12)	5
Mixed (13)	3

Species planted on the windward side should form the most dense barrier practical to block snow and wind.

The herbaceous cover strip should be as wide as possible to maximize wildlife food and cover uses. Legume and grass combinations are best. Acceptable species include alfalfa, sweetclover, tall wheatgrass, intermediate wheatgrass, pubescent wheatgrass, or similar species.

MAINTENANCE AND MANAGEMENT

Care of windbreaks does not end with the planting of trees. Windbreaks must be cultivated, weeds and grass kept out, insects controlled, and water conserved or diverted to their use. Livestock must be kept out of windbreaks at all times and cultivation maintained for at least five years. In dry areas, it may be necessary to cultivate for the life of the windbreak.

In planting the windbreak, the soil should be fallowed at least one year prior to planting (Johnson and Anderson 1980). In the fall, trees should be planted in strips and cultivated to protect against blowing soil and to catch snow during winter.

LABOR/MATERIALS

The Soil Conservation Service and the USDA Forest Service conduct programs that make trees and shrubs available to land owners specifically to plant as windbreaks. Such programs minimize the costs of obtaining the windbreak species. The costs for these trees vary depending on the size of the windbreak and the species planted. Most young (0.6 to 0.9 m [2 to 3 ft]) trees cost \$20 to \$30 per 100. The major cost for this action will be cultivating the soils to establish the windbreaks and then, on a yearly basis, to maintain the breaks. These costs will involve labor, equipment usage, and maintenance.

SOURCES OF INFORMATION

- o State Regulatory Agency
- o U.S. Soil Conservation Service
- o County Extension Agent
- o State Game and Fish Agency
- o U.S. Bureau of Land Management
- o U.S. Forest Service

For addresses, see Appendix A.

References Cited:

- Ferber, A. E. Windbreaks for conservation. USDA Soil Conservation Serv. Agr. Information Bull. 339; 1969. 29 p.
- Heintz, R.; Helwig, L.; Hinds, L.; Hintz, D.; Umland, E. Undated. Tree planting handbook for the Dakotas. This document can be obtained from the North Dakota Extension Service, State University Station, Fargo, ND 58102.
- Johnson, R. L.; Anderson, E. S. (eds.). Conservation planting handbook for Wyoming and Colorado. Ag. Ext. Serv., Univ. of Wyoming; 1980.
- Yoakum, J.; Dasmann, W. P. Habitat manipulation practices. Giles, Robert H., ed. Wildlife management techniques. Washington, D.C.: The Wildlife Society; 1971:173-232; 1971.

d. Rock piles.

PURPOSE

Rock piles provide several benefits to wildlife, such as:

- o perching sites;
- o protection from the elements;
- o concealment and protection for small mammals from predators;
- o nest sites; and
- o may enhance snow catchment and encourage vegetative development.

Rock piles are most beneficial to small game and nongame animals, especially on newly reclaimed areas where cover is minimal. Development of rock piles is also useful for enhancement of wildlife habitat in undisturbed areas adjacent to mining activities. As a mitigative measure, rock piles can be used to replace certain types of habitat lost during mining. Single boulders or clusters also provide useful wildlife habitat.

DEVELOPMENT

Rock piles are most easily constructed when the removal of rocks from topsoil is necessary for reclamation. Suitable rock can be stockpiled for placement after final grading, or disposed of directly on regraded areas.

Coarse material (rocks > 0.5 m in diameter) should be used for building rock piles (Figure 3.3-20). Coarse rocks provide more space and openings within a pile, are more stable, and are less subject to weathering than fine material. Rock piles intended as denning sites should be large enough to provide a relatively stable interior environment. Piles greater than 4 m (L) x 4 m (W) x 2 m (H) are usually sufficient to meet this criterion. Both the size of the material and the pile itself can influence what species of wildlife will utilize the rock structures and what they will use them for. Rock piles intended primarily for raptor perches or nest sites should be placed on the leeward side of hills, near (but not on) ridgetops (Phillips 1981; Tessman 1982). Such piles should consist of two or three boulders propped together that are as large as equipment can handle (Phillips 1981; Tessman 1982). Rock piles intended for small mammal use are more desirable along bottoms and in other protected areas (Tessman 1982). Rock piles are not advantageous in areas where such natural habitat does not exist. Recommendations on rock pile sizes, placement, and number can be made by a local wildlife biologist. There are no formal guidelines to follow for constructing rock piles, and almost any rock pile will benefit wildlife. Some general design criteria include:

- o Several smaller (e.g., 4 m x 6 m x 2 m), interspersed rock piles will be more beneficial than one large pile.
- o Boulders should be large enough so that, once piled, there is a maze of spaces within the pile.

- o In general, the greater "edge" (see Section 3.3.3.b, Planting Patterns to Increase Wildlife Diversity) the rock pile has (i.e., the more irregular the configuration), the more value it will have for wildlife.
- o Rock piles do not have to be neatly arranged. Several dump truck loads piled next to or on top of each other will be adequate.



Figure 3.3-20. A rock pile for use by amphibians and reptiles (from Johnson 1978).

MAINTENANCE AND MANAGEMENT

Rock piles require no maintenance. With proper stable placement and selection of durable materials, rock piles can be expected to provide benefits to wildlife for a considerable time.

LABOR/MATERIALS

Large rocks and boulders are readily available at some stage of the mining operation. Proper planning, such as stockpiling suitable boulders, can keep equipment usage to a minimum. When rock removal is necessary for reclamation, the creation of rock piles can reduce disposal costs. Any lifting equipment (high-lift front end loader) can be used for material handling. Placement of rocks is performed most economically by dump truck when long distance hauls are involved. The loading and placement of rocks for a pile 3 m (10 ft) in diameter by 1 m (3 ft) high should require 1-2 man-hours of labor and similar front-end loader and dump truck time.

SOURCES OF INFORMATION

Information on the usefulness, placement, and size requirements of rock piles to benefit wildlife can be obtained from:

- o State Regulatory Authority
- o Office of Surface Mining
- o State Game and Fish Agency
- o U.S. Fish and Wildlife Service
- o U.S. Forest Service

For addresses, see Appendix A.

References Cited:

Johnson, T. R. Tips on the management of amphibians and reptiles on private lands. Jefferson City, MO; Missouri Department of Conservation; 1978.

Phillips, R. Personal communication; 1981. (As cited in Tessman [1982]).

Tessman, S. Measures for restoring wildlife habitat on reclaimed mine lands. Wyoming Game and Fish Department; 1982.

Additional References:

Thomas, J. W., ed. Wildlife habitats in managed forests: The Blue Mountains of Oregon and Washington. USDA Forest Service, Agriculture Handbook No. 553: published in cooperation with Wildlife Management Institute and USDI Bureau of Land Management; 1979.

e. Brush piles.

PURPOSE

Brush piles provide several benefits to wildlife, such as:

- o concealment and protection from predators;
- o protection from the elements; and
- o nesting habitat.

These structures are especially beneficial in areas of limited small mammal and bird habitat, such as newly reclaimed areas or wetlands.

DEVELOPMENT

There are many methods of constructing brush piles. Depending on the situation and availability of materials, construction may be accomplished in several ways. Residual brush materials, logs, or boulders may be utilized together or separately to provide a general habitat for small animals (Figure 3.3-21) (Gutiérrez et al. 1979). When scattered throughout an area, these piles provide valuable habitat for many different types of small animals. The number and location of brush piles can be determined by consulting with a local wildlife biologist or soil conservationist.

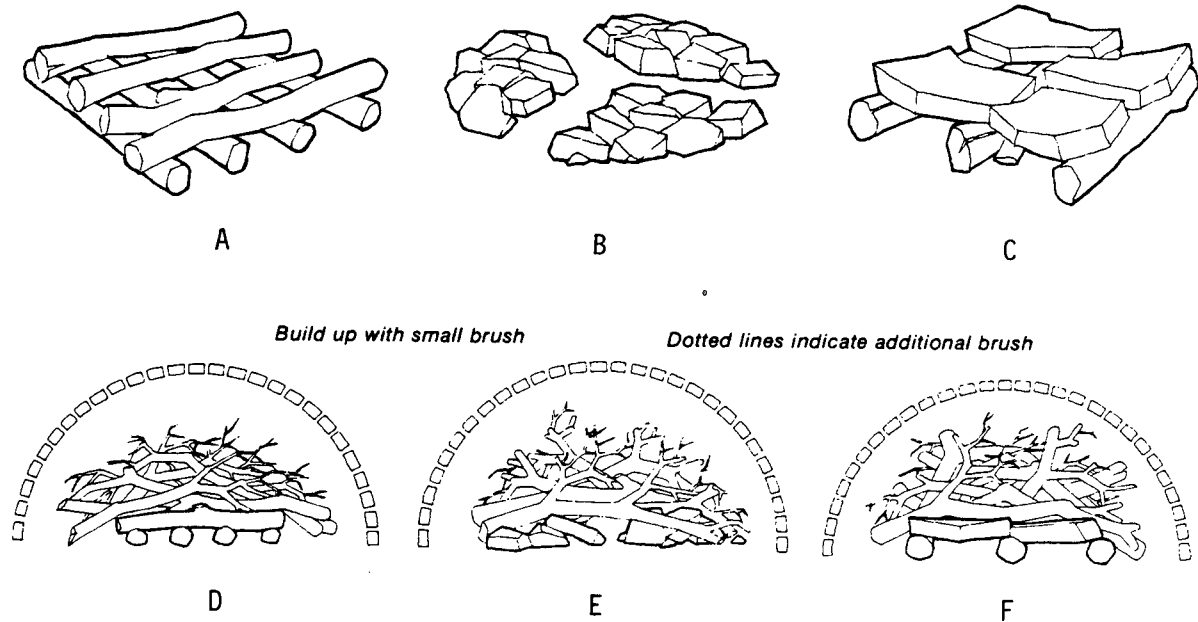

Figure 3.3-21. Construction of brush pile shelters demonstrating base construction methods and construction with dead brush (D-F) (A-Logs, B-Boulders, C-Log/Boulder Combination) (from Gutiérrez et al. 1979).

In the West, brush piles can often be made with woody materials, such as mature sage, placed parallel to the prevailing winds. Cables should be placed over the top of the brush piles and secured with stakes. Several small brush piles are more useful to small mammals and birds than one large pile.

Brush piles may be constructed specifically for duck nesting sites on or near newly-constructed wetlands or impoundments. Brush piles for ducks should be located on islands surrounded by water, but shorelines or open wetlands may be selected. The location should be protected from erosion and prevailing winds and should be 0.3 to 1 m (1 to 3 ft) from the water's edge. The distance from the water will vary with species and can be determined by consulting with a local wildlife biologist or soil conservationist. Construction should include the following steps (Warrick 1976).

- o Collect brush (0.6 to 5 cm [$\frac{1}{4}$ to 2 in] diameter twigs which are 0.3 to 1.2 m [1 to 4 ft] in length) and a bundle of native grass.
- o Dig a bowl shaped depression (15.2 cm [6 in] deep and 30.5 cm [12 in] in diameter).
- o Build a canopy over the depression by pushing twigs (45.7 to 61 cm long [18 to 24 in] 20 cm (8 in) into the soil, at an angle of 60°, leaving a 15.2 x 15.2 cm (6 x 6 in) opening at ground level.
- o Put native grass throughout the inside of the canopy and depression.
- o Weave more twigs into the canopy and place a layer of dense brush over the entire pile. Be sure that the 15.2 x 15.2 cm (6 x 6 in) opening remains free.

The brush should be weighted at one end or pushed into the soil to provide stability. Construction should be completed prior to the arrival of migratory species in the spring.

MAINTENANCE AND MANAGEMENT

The brush piles will provide benefits to wildlife for several years with very little maintenance. The materials may eventually blow away but will provide shelter for a few years until natural shelter can be established.

LABOR/MATERIALS

Materials are generally available from stripmine clearing operations. These can be hauled to the reclamation sites in dump trucks or front end loaders. An individual can construct one of these structures in 20 to 30 minutes.

SOURCES OF INFORMATION

More information on the use of brush piles may be obtained from:

- o State Regulatory Authority
- o State Game and Fish Agencies
- o State Soil Conservation Offices
- o U.S. Fish and Wildlife Service
- o U.S. Forest Service
- o U.S. Bureau of Land Management
- o Other wildlife management agencies
- o Office of Surface Mining

For addresses, see Appendix A.

References Cited:

Gutiérrez, R. J.; Decker, D. J.; Howard, R. A., Jr.; Lassoie, J. P. Managing small woodlands for wildlife. Extension Publication, Info. Bull. No. 157. New York State College of Agriculture and Life Sciences at Cornell University, Ithaca; 1979.

Warrick, C. W. Artificial brush piles. USDI, Bureau of Land Management, Tech. Note 290. Denver, CO; 1976.

Additional References:

U.S. Forest Service. Wildlife habitat improvement handbook. Forest Service Handbook No. 2609.11. Washington, D.C.: USDA Forest Service; 1969.

f. Construction of nesting structures for birds.

PURPOSE

A lack of natural nest sites, food, water, or any other habitat requirement can limit wildlife success and distribution in an otherwise suitable habitat. Artificial nest structures provide substitute nest sites in areas where former sites have been destroyed, are naturally lacking, and/or have not reached the required successional stage.

DEVELOPMENT

Graul (1980) stresses that the use of artificial structures is a species-specific management objective and may not be compatible with the habitat needs of the wildlife community. Management practices should be directed towards restoring or maintaining natural relationships between the various wildlife species of the area. Any artificial nesting structure should be carefully evaluated prior to its use. As a result, a detailed analysis of the specific site under construction and all species present in the area should precede any development. For example, placement of a golden eagle nesting platform on a powerline tower adjacent to a sage grouse lek (courting grounds) would not benefit all wildlife. When artificial nest structures are employed, a follow-up evaluation should be conducted to determine if the structure achieved the intended goal (Graul 1980).

Nest Boxes

Nest boxes ("bird houses") benefit a wide variety birds, including songbirds, various perching birds, woodpeckers, owls, and kestrels. These can be placed on trees, utility poles, fence posts, or on abandoned buildings. The structures must meet the requirements of the desired species and be properly designed, located, erected, and maintained for beneficial results (Yoakum et al. 1980). Furthermore, they must be durable, predator proof, weathertight, lightweight, and economical to build (Yoakum 1971). Nest-box dimensions are listed in Table 3.3-12 for a variety of bird species in the Powder River-Fort Union Coal Region. For more information, see Kalmbach et al. (1969) and Shomon et al. (1966).

Nest Platforms

Nesting platforms are constructed to benefit raptors and geese. For raptors, platforms (Figure 3.3-22) can be mounted on top of trees (living or dead) or on utility poles. Such structures serve a number of species, including eagles, ferruginous hawks, and great horned owls (Yoakum et al. 1980) (see Section 3.3.3.g, Building Alternative Nest Sites for Golden Eagles). An excellent review of a variety of raptor nest structures is contained in Olendorff et al. (1980).

Table 3.3-12. Nest box dimensions and placement height (adapted from Kalmbach et al. 1969).

Species	Floor of Cavity cm	Depth of Cavity cm	Entrance above Floor cm	Diameter of Entrance cm	Height above Ground ¹ m
Bluebird	13 x 13	20	15	4	1.5-3
Robin	15 x 20	20	(²)	(²)	1.8-4.5
Chickadee	10 x 10	20-25	15-20	3	1.8-4.5
Nuthatch	10 x 10	20-25	15-20	3	3.7-6
House wren	10 x 10	15-20	3-15	2.5-3	1.8-3
Swallows	15 x 15	15	3-13	4	2.4-4.5
Phoebe	15 x 15	15	(²)	(²)	2.4-3.7
Flycatchers	15 x 15	20-25	15-20	6.5	1.8-6
Flicker	18 x 18	41-46	36-41	6.5	1.8-6
Downy woodpecker	10 x 10	23-30	15-20	3	1.8-6
Hairy woodpecker	15 x 15	30-38	23-30	4	3.7-6
Screech owl	20 x 20	30-38	23-30	7.5	3 -8
Saw-whet owl	15 x 15	25-30	20-25	6.5	3.7-6
Barn owl	25 x 46	38-46	10	15	3.7-5.5
Sparrow hawk	20 x 20	30-38	23-30	7.5	3 -9

¹Data indicate that boxes at moderate heights, mostly within reach of a man on the ground, are readily accepted by many birds.

²One or more sides open.

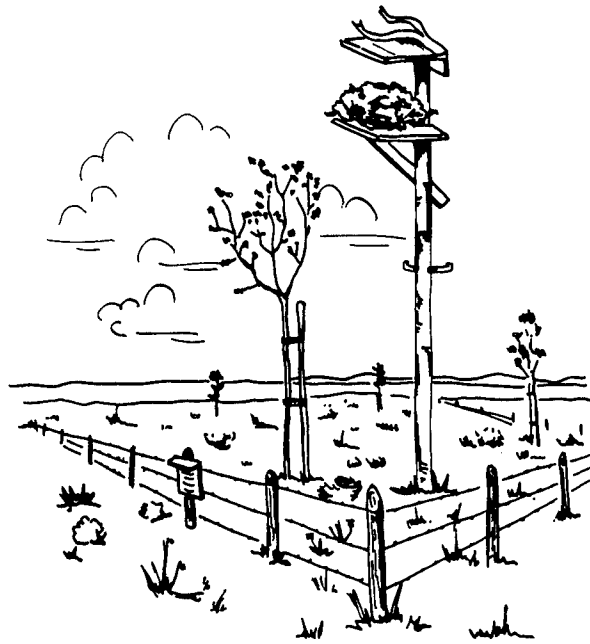

Figure 3.3-22. Diagram of artificial raptor nest platform with sunshade and perch mounted on utility pole (after Yoakum et al. 1980, modified from Olendorff and Stoddart 1974).

The nest platform should provide:

- o shade for the young birds;
- o a large platform for nest construction; and
- o a base high enough to prevent dangling nesting materials from contacting wires (Nelson and Nelson 1976).

These platforms have been used successfully by nesting golden eagles, ferruginous hawks, red-tailed hawks, and ravens. Utilities should be consulted prior to any construction of nesting structures on power poles.

Grubb (1980) developed a tripod-teepee nesting structure (Figures 3.3-23 and 3.3-24) for bald eagles which supports a nest more than 10.6 m (35 ft) above the ground. The stability and ease of locating this structure has made it ideal for relocating eagle nests or simply providing additional nest sites for a variety of raptors. Grubb has also provided a detailed discussion of construction, materials, and manpower needs. The estimated cost of materials, including an hour of helicopter time, was \$1,200. Approximately 150 man-hours were required for site preparation, construction prior to field assembly, and setting the structure.

A variety of artificial structures (wooden nest boxes, wash tubs, 55 gallon barrels cut lengthwise, tires, and floating rafts) have been used successfully by nesting Canada geese. These structures are either a floating raft type anchored in water or some type of platform supported off the ground (2.1-m [7-ft]).

Both types provide security from predators; on islands within impoundments, these structures can be placed on the ground. Nesting materials composed of hay, wood shavings, or natural vegetation are tightly packed on or in the structure to form a nest.

Because of the numerous variations of these platforms, the cost and effort involved in construction varies widely. For more information on the design and placement of these structures, see Saake (1968), Will and Crawford (1970), Bone (1972), and Yoakum et al. (1980).

Nest Baskets

Conical nest baskets for ducks have been constructed out of 0.6 cm (1/4 in) hardware cloth, reinforcing rods, and a galvanized pipe support for placement in shallow water. For more information on these structures, including a complete list of materials, construction procedures, and placement considerations, see Yoakum et al. (1980).



Figure 3.3-23. Finished tripod apex with attachments (from Grubb 1980).

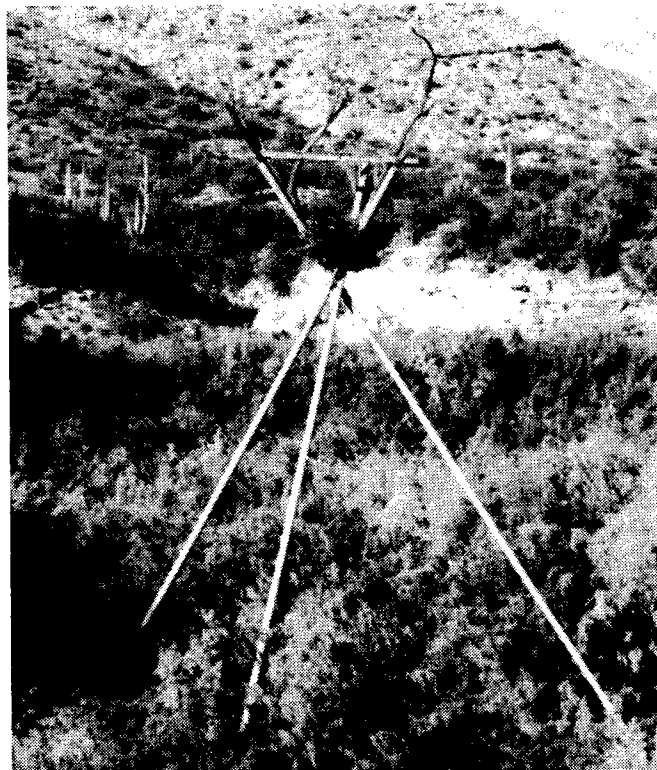

Figure 3.3-24. Overview of raptor nesting tripod (from Grubb 1980).

Brush piles (see Section 3.3.3.e, Brush Piles) also provide nesting sites for ducks when installed near newly-constructed wetlands or aquatic habitat.

Nest Cones

Because the loosely constructed twig nests of mourning doves are easily destroyed during storms, Cowan (1959) developed artificial nest cones to improve nestling survival. The cones are constructed out of a 30.5-cm (12-in) square of 0.6-cm (1/4-in) or 1-cm (3/8-in) mesh hardware cloth and can be installed with nails in the forks of tree branches. Recommended sites must have good visibility, provide adequate clearance for the birds to easily escape danger, and occur in modest shade, 1.8 to 4.9 m (6 to 16 ft) above the ground. The best results will be obtained by installing the cones in late winter or early spring prior to nesting territory selection. Annual maintenance is required to clean out old nesting materials and ensure that the cones are securely fastened.

Nest Burrows

The decline of burrowing owls throughout much of their historic range is primarily due to the loss of burrows, caused by control of burrowing mammals and the loss of habitat to urban, industrial, and agricultural development (Zarn 1974). Collins and Landry (1977) were able to enhance a local burrowing owl population through the use of artificial nest burrows (Figure 3.3-25). These were constructed out of exterior plywood with a natural dirt floor. The tunnel was 1.8 m (6 ft) long, with an opening of 10 x 10 cm (4 x 4 in), and one right angle turn approximately 1.2 m (4 ft) from the entrance to maintain darkness. The tunnel complex was attached to a 30.5 x 30.5 x 20 cm (12 x 12 x 8 in) nesting chamber. The entire structure was covered with 15 cm (6 in) of soil to provide thermal stability in the chamber.

Nest Cover

Normal revegetation during reclamation will produce suitable nesting cover for a variety of grassland nesting birds and other small mammals. Shomon et al. (1966) provide suggestions for maintaining and enhancing nest cover for wildlife:

- o Maintain permanent, undisturbed cover along fences, roads, railroad rights-of-way, and odd corners wherever possible.
- o Fence nesting cover to prevent damage by livestock grazing.
- o Plant shrubby thickets along gulleys and draws for wildlife.
- o Refrain from dryland fallowing operations during the nesting season so that ground nesting birds can raise their brood in the stubble habitats.
- o Use devices on mowers to flush nesting females during crop cutting.



Figure 3.3-25. Installation and operation of artificial burrowing owl nest burrows. (A) the unassembled burrow components; (B) excavation; (C) artificial burrow ready to be buried; and (D) burrowing owls in excavated burrow (Modified from Collins and Landry 1977) (Reprinted with permission, from North American Bird Bander 2:152).

SOURCES OF INFORMATION

- o State Regulatory Authority
- o Office of Surface Mining
- o U.S. Fish and Wildlife Service
- o U.S. Forest Service
- o U.S. Bureau of Land Management
- o State Game and Fish Agencies

For addresses, see Appendix A.

References Cited:

- Bone, T. Ecology of Canada geese. Influence of artificial nesting structures on Canada goose population. Wyo. Game and Fish Job Completion Rep., W-71-R-8; 1972.
- Collins, C. T.; Landry, R. E. Artificial nest burrows for burrowing owls. N. Amer. Bird Bander 2(4):151-154; 1977.
- Cowan, J. "Pre-fab" wire mesh cones give doves better nest than they can build themselves. Outdoor Calif. 20(1):10-11; 1959.
- Graul, W. D. Grassland management practices and bird communities. Proceedings of management of western forests and grasslands for nongame birds. USDA Forest Service Tech. Rep. INT-86; 1980:38-47. Intermountain Forest and Range Exp. Sta., Ogden, UT; 1980.
- Grubb, T. G. An artificial bald eagle nest structure. USDA Forest Service Res. Note RM-383: Rocky Mountain Forest and Range Exp. Stn., Fort Collins, CO; 1980. 4 p.
- Kalmbach, E. R.; McAtee, W. L.; Courtsal, F. R.; Ivers, R. E. Homes for birds. US Fish and Wildl. Serv. Conserv. Bull. 14; 1969.
- Nelson, M. W.; Nelson, P. Power lines and birds of prey. Idaho Wildl. Rev. 28(5):3-7; 1976.
- Olendorff, R. R.; Stoddart, J. W. The potential for management of raptor populations in western grasslands. Hammerstown, F. N.; Harrell, B. E.; Olendorff, R. R. eds. Management of raptors. Raptor Res. Rep. No. 2, Raptor Res. Found., Inc., Vermillion, SD; 1974.
- Olendorff, R. R.; Motroni, R. S.; Call, M. W. Raptor management - the state of the art in 1980. Proceedings of management of western forests and grasslands for nongame birds: USDA Forest Service Tech. Rep. INT-86, Ogden, UT; 1980.
- Saake, N. Nevada's Canada geese. Nev. Wildl. 2(2):24-25; 1968.

- Shomon, V. V.; Ashbaugh, B. L.; Tolmon, C. D. Wildlife habitat improvement. New York: Natl. Audubon Soc.; 1966.
- Will, G. C.; Crawford, G. I. Elevated and floating nest structures for Canada geese. J. Wildl. Manage. 34(3):583-586; 1970.
- Yoakum, J. Habitat improvement. Teague, R. D. ed. A manual of wildlife conservation. Washington, D.C.: The Wildlife Society; 1971.
- Yoakum, J.; Dasmann, W. P.; Sanderson, H. R.; Nixon, C. M.; Crawford, H. S. Habitat improvement techniques. Schemnitz, S.D. ed. Wildlife management techniques manual. Washington, D.C.: The Wildlife Society; 1980.
- Zarn, M. Burrowing owl, Speotyto cunicularia hypugaea. Endangered species Rep. No. 11, Habitat management series for unique or endangered species. Denver, CO: USDI Bureau of Land Management; 1974.

g. Building alternative nest sites for golden eagles.

PURPOSE

The golden eagle is not on the Federal Endangered Species List, yet golden eagles and their nests are afforded protection by amendment to the Bald Eagle Protection Act of 1940 and the Wildlife Improvement Act of 1978. Although the Bald Eagle Protection Act authorizes the Secretary of the Interior to issue permits for the taking of golden eagles that interfere with resource development or recovery operations, viable alternatives exist which make it possible to relocate golden eagles away from mining areas or to return them to reclaimed areas. This is important because golden eagles are year-round residents of the Powder River Basin. Recognizably, the task is not an easy one because the eagles have nests that they return to year after year.

DEVELOPMENT

The technique described below for building an alternative nest site for a golden eagle has been tested by Jim Grier, Howard Postovic, and Jim Tate on ARCO's Coal Creek lease in the Powder River Basin. The project was begun in May 1979 and was continuing as of Spring 1982. To conduct the project, the investigators received approval from the U.S. Fish and Wildlife Service, the Wyoming Department of Game and Fish, and the Land Quality Division of the Wyoming Department of Environmental Quality.

The nesting structure used consists of an oval wooden platform large enough to hold a nest 0.6 m (2 ft) or more in diameter. The platform is attached to a 12-m (40-ft) pole that runs through one end. Short pegs are attached to the pole to support shading material, while a steel collar around the pole prevents theft of eggs by raccoons.

One month after hatching, the investigators moved a chick from the original nest to the platform that had been built 165 m (550 ft) away. After 45 hours, the female began to feed the chick. A week after the adults accepted the new nest, the chick was again moved to another platform 705 m (2,350 ft) from the original nest. The second site was accepted by the parents within 23 hours. Six days later, the chick was again moved 1,305 m (4,350 ft) from the original nest site. This time, the male accepted the new site within six hours, the female the next morning. The chick fledged before being moved again.

All platforms were removed in 1981 except the one from which the chick had fledged in 1980 and another platform 2.3 km (1.4 mi) from the original nest. This latter platform was the desired site for relocating the eagle nest. While the platforms were being removed, the original nest (1980) was moved 2.3 km (1.4 mi) from the tree to the preferred new site. This gave the eagle pair three choices in 1981: (1) build a new nest in the tree; (2) build a new nest at the 1980 fledging platform; or (3) occupy the nest at 2.3 km (1.4 mi). Observations during 1981 showed that the latter choice was selected. A single egg hatched, and the young eagle eventually fledged.

The investigators recommended that, before moving nesting eagles, one should first get to know the habits and movements of the adult eagles. Moves should be made within the adults' existing home range and, if possible, the move should be towards the center of the range. Chicks and adults should be intensively monitored both prior to, during, and after moves. On the ARCO site, the investigators sometimes had to replace the eaglet in the original nest to protect it from adverse weather.

The U.S. Fish and Wildlife Service (FWS) has cooperated in moving four eagle nests in the Powder River region (Phillips and Beske 1981). The first nest moved was on the Caballo Mine site; the company, in cooperation with the FWS, erected a nesting platform 150 m (500 ft) from the original nest in January 1980. A makeshift nest was installed on the platform and, by March, the adult eagles were incubating two eggs in the platform nest after abandoning their original nest in a cottonwood tree. One eaglet hatched from the platform site in early May.

A permanent site was selected 0.5 km (0.3 mi) from the original nest, and a platform with a nest was erected. The adults refused to accept this nest even after the 4-week-old eaglet was moved to the new site. The eaglet was returned to its original nest after severe weather became a threat. An alternate approach was to construct a nest on a manlift, and the eaglet was moved in successive stages over seven days to the permanent relocation. The original cottonwood tree was cut down to prevent the return of the adult pair.

In a second move (at Kerr-McGee's Jacobs Ranch Mine), a nest was built among some ponderosa pines which were regularly used for perching and roosting. This pine stand was 1 km (0.6 mi) from a nest site. A nesting platform was then constructed halfway between the occupied nest and the desired nest site. When four weeks old, the eaglet was moved to the platform. The parents were feeding the young eagle at the new site within 24 hours. Six days later, the eaglet was moved to the nest in the pine trees, and the adult eagles again accepted the chick at this site.

Two young eagles have been successfully moved 100 m (330 ft) to a platform nest at Arco Coal's Black Thunder Mine. The adult pair will be monitored to see if they continue to accept the platform nest. At the Wyodak Resources Mine, the entire tree used for nesting by an eagle pair was cut off at the base and moved with heavy equipment to a site 0.8 km (0.5 mi) from the old location. The success of this move is also being monitored.

Fyfe and Olendorff (1976) have discussed some of the dangers to eggs or young as a result of these nesting studies. To minimize the chances of the adult deserting the nest, it is suggested that long nest visits be delayed until late in the nesting season and preferably until after hatching. Howard Postovic also strongly suggests that the nest be avoided during courtship through a couple weeks into incubation to avoid abandonment of the nest by the parents. He also recommends that trees be planted at the new nest site early in the move process so that there will be nesting structures available for future generations. The nests of birds that have been consistently unsuccessful in fledging young in the past should be avoided. It is also suggested

that when conducting aerial surveys, approaches to nest sites should be avoided. When approaching a nest, care should also be taken to eliminate the element of surprise whenever possible. This is to avoid startling the parent and causing the egg or the hatchling to be crushed or puncturing the eaglet with a talon. If a parent bird is reluctant to fly, an investigator should retreat and visit the nest after hatching is completed.

When parents are frightened from a nest, eggs and young are exposed to the dangers of overheating, cooling, or loss of moisture. Dehydration can be especially critical at hatching. In general, visits to the nest should be kept short, and factors such as weather, sun position, and time of day noted. In unshaded areas, visits should be restricted to the cooler parts of the day. For extended visits, eggs should be covered with a soft cloth to slow down the loss of heat and moisture.

Several missed feedings in a row are not likely to kill young raptors except for hatchlings of only a few days of age. Eagles can survive extended periods of fasting (Fyfe and Olendorff 1976).

As fledging approaches, the young eagles or falcons are disposed to leave the nest or ledge (Grier 1969). Therefore, movements around a nest should be slow and deliberate to keep from startling the young and causing them to leave the nest prematurely. When a young bird does jump from a nest, it should be immediately retrieved, checked for injury, and returned to the nest.

Predators can be attracted to nests by scent trails laid down by humans. The proper way to approach a nest is to walk past it at a distance, retrace a portion of the path, and then walk along a single right-angled side trail to the nest. Sprinkling the side trail with naphthalene crystals during the exit covers the human scent and decreases the chance of nest predation.

Young birds should only be handled when necessary; handling may lead to injury. Only when necessary, the birds should be picked up with both hands. Very young birds can be cradled in one hand and held firmly with the thumb. Medium-sized chicks should be held by both legs and stabilized against the body. If the bird falls over in one's hand, it should be laid on its back. For large birds such as golden eagles, it is best to pin the bird to the nest with one hand while the other hand searches underneath for the feet.

For additional information on building alternative nest sites, see Section 3.3.3.f, Construction of Nesting Structures for Birds.

MAINTENANCE AND MANAGEMENT

Overall maintenance of the structure should be minimal and may require little if any follow-up costs once a permanent location has been selected. Monitoring the success of renesting would involve some cost, depending upon the level of effort.

LABOR/MATERIALS

Materials for constructing the artificial nests consist mainly of a large diameter pole and wooden materials for constructing the nest platform. Costs for material and labor for constructing the structure should be minimal; however, some equipment may be needed to erect the structure. A liberal estimate of the costs involved would be \$1,000 per nesting structure, including costs for materials, construction, and labor.

SOURCES OF INFORMATION:

- o State Regulatory Agency
- o Office of Surface Mining
- o ARCO Coal
- o U.S. Fish and Wildlife Service
- o State Fish and Game Agencies
- o U.S. Bureau of Land Management

For addresses, see Appendix A.

References Cited:

- Fyfe, R. W.; Olendorff, R. R. Minimizing the dangers of nesting studies to raptors and other sensitive species. Can. Wildl. Serv. Occ. Paper No. 23; 1976.
- Grier, J. W. Bald eagle behavior and productivity responses to climbing to nests. J. Wildl. Manage. 33:961-966; 1969.
- Phillips, R. L.; Beske, A. E. Resolving conflicts between nesting golden eagles and energy development. Paper presented at 43rd Midwest Fish and Wildlife Conference. Wichita, KS; 1981.

h. Maintenance of sage grouse and sharp-tailed grouse habitats.

PURPOSE

Sage and sharp-tailed grouse are two gallinaceous birds which can be expected to occur in select areas in the Powder River-Fort Union Coal Region (Miller and Graul 1980). As game species, they have economic value and are managed by wildlife departments of the States where they occur. These species have specific habitat requirements and plans should be made for the maintenance of resident populations.

Mine operators should consult with the State regulatory authority and the game and fish department before any critical habitat component (identified during baseline studies) is disturbed and before any habitat restoration is attempted.

SAGE GROUSE

Recent studies on sage grouse have concentrated on moving leks (display grounds) which will be destroyed by mining (James Tate, ARCO Coal; John Monarch, Pittsburgh-Midway; Robert Eng, Montana State University, pers. comm.). The technique has been to create a new lek, usually a clearing on a high point, and then attempting to induce birds to use it by playing tapes of male sage grouse "booming" and by setting out decoys.

Variable success has been achieved in getting the birds to move their display grounds. The most recent research suggests that, although a lek may be destroyed by mining--if adequate habitat is available nearby, hens may still produce the same number of chicks (H. Harju, Wyoming Game and Fish Department; J. Tate, ARCO Coal Co., pers. comm.). The current emphasis (Tate et al. 1979; Colenso et al. 1980) is on developing standards for all habitat components, such as winter habitat, nesting cover, and brood habitat, so that reclamation can focus on any portion of sage grouse habitat that will be impacted or is naturally limiting. The following is a brief summary of sage grouse habitat requirements to be considered where mitigation is planned.

Food Habits

Because sage grouse lack a muscular gizzard for grinding food, they require soft materials for food. In fact, sage grouse are solely dependent on sagebrush from October through April (Braun et al. 1977). In May, sage grouse shift from the sagebrush diet to one dominated by forbs; the shift is reversed in September.

Breeding and Nesting Areas

Open areas surrounded by sagebrush (Figure 3.3-26) serve as strutting grounds (leks). Most sage grouse movements during the breeding season occur within 1 km (0.6 mi) of the lek (Wallestad and Schladweiler 1974).



Figure 3.3-26. Male sage grouse on strutting ground (Photo courtesy of Colorado Division of Wildlife).

Most nesting occurs under sagebrush within a few kilometers (miles) of the lek (Braun et al. 1977). Sagebrush commonly used for nesting varies between 17 and 79 cm (6.6 to 30.8 in) in height. Most nests are located under the tallest bushes available. Areas where the canopy coverage is 20 to 40% are most frequently used for nesting. Colenso et al. (1980) found that in northwest Wyoming the favored nesting habitat consisted of sagebrush with a mean height of 27 cm (10.5 in) with 25% cover.

Brood Rearing

Johnsgard (1973) summarized studies that found that young broods use areas having a lower plant density and crown cover (23 to 38 cm [9 to 14.8 in]) than older broods or adults (18 to 64 cm [7 to 25 in]). Martin (1970) found most broods were in areas having an average canopy cover of 14% while adults occupied sites averaging 25% cover.

Wintering Areas

The extent of seasonal movements of sage grouse vary with the severity of winter weather, topography, and vegetative cover. Braun et al. (1977) reported studies showing that most sagebrush use in winter is in the "greater than 20%" canopy coverage class. However, during winter, the grouse may be restricted to less than 10% of the sagebrush-dominated lands. Wintering areas hold some of the highest densities of sage grouse and may be used on an annual basis by birds from several leks (Eng et al. 1979). These areas, therefore, have considerable influence on the area-wide grouse population.

Recommended Guidelines

- o Although sagebrush is essential to the sage grouse, homogeneous stands do not receive highest use (Colenso et al. 1980); sagebrush intermixed with forbs should be provided. Habitat patchiness will increase the edge-effect, which will not only benefit sage grouse, but will increase the diversity and abundance of other game and nongame wildlife.
- o Nesting stands should have sagebrush canopy coverage of 20 to 40% and heights should vary between 17 and 79 cm (6.6 and 30.8 in) (Braun et al. 1977).
- o Open areas, 0.1 to 0.2 ha (0.25 to 0.5 acre) in size, surrounded by sagebrush, should be available for strutting grounds (Johnsgard 1973).
- o For brood rearing, less dense stands with lower canopy cover should be available. Average canopy cover of 14% (Martin 1970) and height of 23 to 38 cm (9 to 14.8 in) (Johnsgard 1973) are used by young broods.
- o Wintering areas may be a limiting habitat component. Baseline studies before mining should define these areas, which can then be preserved.

- o Increasing the carrying capacity of adjacent land is one method of mitigating loss of sage grouse habitat. Fertilization or irrigation of sagebrush on adjacent lands may increase the forage production enough to allow more birds to inhabit less space. (See Section 3.1.2, Habitat Improvement on Adjacent Areas to Increase Carrying Capacity).

In summary, it must be remembered that sagebrush is a climax species; to replace a stand to usable proportions from seed may take 30 years (Clait Braun personal communication, Colorado Division of Wildlife, 317 W. Prospect Rd., Ft. Collins, CO 80526). Mitigation of this important sage grouse habitat should include transplanting of sagebrush.

It is important not to concentrate totally on one component, but to consider all components of a necessary habitat when designing a mitigation plan. Local conditions and sage grouse habitat needs will vary.

SHARP-TAILED GROUSE

The Columbian sharptail is the subspecies found in the Powder River-Fort Union Coal Region. It is a bird which thrives on early successional vegetation (Kirsch et al. 1973) and therefore requires management practices different from the sage grouse.

Food Habits

Sharptails' food habits vary seasonally, depending on food availability. Weed seeds, small grains, buds, and insects are eaten in summer and fall (U.S. Fish and Wildlife Service 1978), while winter foods consist of the buds and seeds of fleshy hawthorn, Russian olive, silver buffaloberry, western snowberry, Wood's rose, serviceberry, willow, and chokecherry (Evans and Dietz 1974).

A study by Kirsch et al. (1973) in North Dakota indicated that, by the end of the third growing season, newly planted areas are suitable sharp-tailed grouse habitat. This study indicated that sharptail habitat can be developed on cultivated land by planting brome, brome-alfalfa mixtures, or alfalfa and sweetclover. Kirsch et al. (1973) recommended that either cultivated land or native prairie be maintained in a vigorous subclimax condition by prescribed burning.

Breeding and Nesting Areas

Researchers have found that sharptail nest sites vary relative to the vegetative composition. Pepper (1972) found sharptails in Saskatchewan nesting in various vegetative situations and concluded that the vegetative structure is more important than plant species composition. Sisson (1976) found sharp-tail nests in open areas with much litter but sparse current growth, again perhaps more a factor of vegetative structure than species affinity. Phillips (U.S. Fish and Wildlife Service, pers. comm.) reported that, in southeastern Montana, sharptails nest under sagebrush or other shrubby vegetation.

Kirsch et al. (1973) found that undisturbed areas were important to sharptail survival. Rogers (1969) reported that all sharptail dancing grounds or leks were on knolls or ridges. Vegetation on these sites consisted mainly of grass and some low weeds. They noted that moderate to lightly grazed grasslands were of only limited importance to breeding sharp-tailed grouse.

A study by the U.S. Fish and Wildlife Service (1977) in southeast Montana suggested that mine noise could interfere with vocalizations of lekking male sharptails and therefore could affect their breeding success and productivity. The data suggests that intense noise may reduce activities of birds already on leks. Even a slight interference with breeding would reduce the productivity of a lek over time.

Brood Rearing

Kobriegen (1965) observed that, in Nebraska, broods used whatever shade was available. After observing 110 broods in Wisconsin, Hamerstrom (1963) concluded that brood cover should be basically grassland, with some shrubs for cover and food sources.

Wintering Areas

Sharp-tailed grouse use woody draws or riparian brushy bottoms extensively in the winter where dried berries and rosehips are available. Evans and Dietz (1974) tested seven winter foods to determine their value in providing energy and protein to the grouse. They found that silver buffaloberry was the best winter food since its fruit is high in energy and remains on the shrubs throughout the winter. Management plans for sharp-tailed grouse populations in the Northern Great Plains should include habitat which will provide fleshy hawthorn and western snowberry as food items in the fall, and silver buffaloberry, Russian olive, and corn as winter food.

Recommended Guidelines

- o Grasslands with a variety of food species should be available for grouse summer use.
- o Breeding sharptails need some undisturbed grasslands along ridges or on knolls for courtship.
- o Shrubs or herbaceous cover should be available to provide shade for nesting and broods.
- o Riparian brushy bottoms that provide cover and food, particularly berries, are vital to winter survival of sharptails.
- o Lekking occurs during short periods in spring and fall, primarily in early morning. Disturbances resulting from mining activities should be minimized during the first two hours after sunrise to reduce the negative impacts to the breeding activities.

SOURCES OF INFORMATION

- o State Regulatory Authority
- o Office of Surface Mining
- o State Game and Fish Department
- o U.S. Bureau of Land Management
- o U.S. Forest Service
- o U.S. Fish and Wildlife Service

References Cited:

- Braun, C. E.; Britt, T.; Wallestad, R. D. Guidelines for maintenance of sage grouse habitats. *Wildl. Soc. Bull.* 5(3):99-106; 1977.
- Colenso, B. E.; Boyce, M. S.; Tate, S. Developing criteria for reclamation of sage grouse habitat on a surface coal mine in northeastern Wyoming. *Symp. on surface mining hydrology, sedimentology and reclamation*; 1980 Dec 1-5; Univ. of Kentucky, Lexington, KY; 1980.
- Eng, R. L.; Pitcher, E. J.; Scott, S. J.; Greene, R. J. Minimizing the effect of surface coal mining on a sage grouse population by a directed shift of breeding activities. *The Mitigation Symposium*; 1979 July 16-20; Colorado State University, Fort Collins, CO. USDA Forest Service, Rocky Mountain Forest and Range Exp. Sta. Gen. Tech. Rep. RM-65; 1979.
- Evans, K. E.; Dietz, D. R. Nutritional energetics of sharp-tailed grouse during winter. *J. Wildl. Manage.* 38(4):622-629; 1974.
- Hamerstrom, F. N., Jr. Sharptail brood habitat in Wisconsin's northern pine barrens. *J. Wildl. Manage.* 27:793-802; 1963.
- Johnsgard, P. A. Grouse and quail of North America. University of Nebraska Press, Lincoln and London; 1973.
- Kirsch, L. M.; Klett, A. T.; Miller, H. W. Land use and prairie grouse population relationships in North Dakota. *J. Wildl. Manage.* 37(4):449-453; 1973.
- Kobrigen, G. D. Status, movements, and foods of prairie grouse on a sandhills refuge. *J. Wildl. Manage.* 29(4):788-800; 1965.
- Martin, N. S. Sagebrush control related to habitat and sage grouse occurrence. *J. Wildl. Manage.* 34:313-320; 1970.
- Miller, G. L.; Graul, W. D. Status of sharp-tailed grouse in North America. *Proceedings of the prairie grouse symposium*; 1980 September 17-18; Oklahoma State University, Stillwater, OK; 1980.
- Pepper, G. W. The ecology of sharp-tailed grouse during spring and summer in the aspen parklands of Saskatchewan. *Saskatchewan Dept. Nat. Resour. Wildl. Rep.* 1; 1972.

- Rogers, G. E. The sharp-tailed grouse in Colorado. Colorado Game Fish Parks Div. Tech. Publ. 23; 1969. 94 p.
- Sisson, L. The sharp-tailed grouse in Nebraska. Nebraska Game Park Commission, Lincoln; 1976.
- Tate, J., Jr.; Boyce, M. S.; Smith, T. R. Response of sage grouse to artificially created display ground. The Mitigation Symposium; 1979 July 16-20; Colorado State University, Fort Collins, CO. USDA Forest Service, Rocky Mountain Forest and Range Exp. Sta. Gen. Tech. Rep. RM-65; 1979.
- U.S. Fish and Wildlife Service. Annual progress report, wildlife research work unit, Denver Wildlife Research Center; 1977.
- U.S. Fish and Wildlife Service. Rehabilitation of western wildlife habitat: A review. FWS/OBS-78/86; 1978.
- Wallestad, R. O.; Schladweiler, P. Breeding season movements and habitat selection of male sage grouse. J. Wildl. Manage. 38:634-637; 1974.

i. Restoring big game range.

PURPOSE

Artificial restoration of mined lands can greatly increase production of forage for game and livestock, and improve soil stability. Reclamation directed towards big game, an ecologically, aesthetically, and economically important wildlife group, actually involves the restoration of a community, which includes and benefits a wide variety of plant and wildlife species.

Active coal mine areas in the Powder River-Fort Union Coal Region are inhabited primarily by two big game species, pronghorn and mule deer. Restoration practices in this section will be oriented toward their specific habitat requirements.

DEVELOPMENT

Development of a reclamation plan for big game range requires the evaluation of two criteria:

- o Did a particular big game species inhabit the area prior to mining, or with the development of a certain habitat requirement, could they have?
- o Would the species be suited to the area if the present habitat were adequately improved? (This assumes the animal would recolonize the area on its own.)

If, for some reason, the former range had never supported a given species, and likely will not when the range is restored (e.g., a situation where the restored range is 16 km [10 mi] from the closest population of deer and is too small to constitute a yearlong range), then perhaps the reclamation effort should be oriented to benefit another group of wildlife. If the restored range could support deer or antelope, a determination must be made regarding whether the range could support the group year-round or seasonally. This distinction is important because the distribution of habitat requirements (food, water, cover) depends upon the type of range being reclaimed. For example, water is much more critical on a late summer and fall antelope range than on a winter range. Once the determination is made, it is essential that all habitat requirements are included. When reclaiming year-round range, all requirements must be abundant enough and properly interspersed to meet the species' yearlong needs.

At most coal mines, the area to be reclaimed is of inadequate size to support a year-round big game population. In such areas, the reclamation goals might be to establish seasonally important habitat components, limited or lacking on adjacent, undisturbed range. Important components often limited include late summer and fall water sources, winter cover, and shrublands which provide food, thermal and escape cover, and fawning areas. These habitat components are addressed below.

Habitat Requirements

Pronghorn occupy ranges characterized by low, rolling, wide-open, expansive terrain. Their zone of maximum abundance and productivity is closely associated with the distribution of big sagebrush and silver sagebrush (Sundstrom et al. 1973) and the general environmental factors associated with these plant communities. Characteristics of optimum pronghorn habitat listed below are based on studies (Sundstrom 1968, 1979; Beale and Smith 1970; Sundstrom et al. 1973; Yoakum 1974, 1978) conducted over several sites, including the Powder River-Fort Union Coal Region.

- o Vegetative cover is relatively open, ranging between 40 and 60%.
- o Height of vegetation averages 38 cm (15 in) above ground level. Range with vegetation exceeding 61 cm (24 in) is less preferred, and ranges with vegetation over 76 cm (30 in) are used infrequently.
- o The general vegetative composition of the range is 40 to 60% grass, 10 to 30% forbs, and 5 to 20% sagebrush or other browse species.
- o The vegetative community contains a variety of species which include 5 to 10 species of grasses, 20 to 40 species of forbs, and 5 to 10 species of shrubs.
- o Preferred species of browse are big sagebrush, fringed sagewort, silver sagebrush, and Douglas rabbitbrush.
- o Open ranges supporting a variety of vegetative types are preferred to monotypic stands. Such areas provide grass sprouts and an abundance of succulent forbs.
- o Water sources must be available during hot, dry periods and able to supply 3 to 5 l (0.8 to 1.3 gal) of water/animal/day. Permanent water sources should not be more than 4.8 to 8 km (3 to 5 mi) apart for proper distribution of animals across the total available range.
- o Landscape irregularities that provide shelter from cold, winter winds and produce microclimates which increase the availability of forage should be present.

Mule deer are remarkably adaptable animals and are ubiquitously distributed throughout a variety of habitats in the western United States. Because of this attribute and the diversity of habitats which exist in the Powder River-Fort Union Coal Region, only generalizations can be made that are applicable on a region-wide basis.

- o Early stages of plant succession are more beneficial than climax vegetation.
- o A mixture of vegetation types provides better habitat than a monotypic community.

- o Browse is essential to winter survival and more browse species are preferred to fewer species.
- o It must be emphasized that optimum habitat for mule deer, as with pronghorn and most other wildlife species, is directly related to the quantity, quality, and interspersion of all essential requirements (see Section 3.3.3.b, Planting Patterns to Increase Wildlife Diversity).

Additional habitat requirements for mule deer are discussed in the following sections.

Water Sources

Big game distribution, forage utilization, fawn survival, and herd productivity can be improved through the development of small, strategically located water sources. Because of the arid nature of their range, water is more critical to antelope than to other big game. The availability of water sources is most critical during mid and late summer. In Wyoming's Red Desert, Sundstrom (1968) observed that 95% of 12,465 antelope located were within a 4.8- to 6.4-km (3- to 4-mi) radius of water. Daily water consumption rates per antelope ranged from 0.34 ℓ (0.09 gal) per day in May to 4.5 ℓ (1.2 gal) per day in August. Water consumption varied with total monthly precipitation, evaporation, availability of succulent vegetation, and average maximum temperature. Baker (1953) found that antelope sometimes died attempting to get through antelope-proof fences to reach water on adjacent range.

Some considerations of water development for big game are listed below.

- o It is more beneficial to provide a number of small, strategically located ponds rather than one or two large lakes.
- o The availability of water is most critical during mid to late summer.
- o Antelope and deer will drink from most facilities designed for livestock use. Such facilities should be available during critical periods.
- o Responsible planning can not only protect and enhance existing water sources but also provide additional ones.
- o Ponds should have some permanent source of water to avoid water quality deterioration.
- o Water quality should be periodically monitored.
- o The best way to insure adequate water on big game range is to maintain existing sources and wildlife access to them.
- o Toxic sediment ponds should be fenced with net wire to prevent intake of contaminated water (see Section 3.1.1.d, Fences).

For information on the construction of water sources, see Supplementary Water Resources (Section 3.3.2.b).

Cover

Cover is required for predator evasion, fawning areas, shelter from the heat and cold, and psychological security, although what constitutes "cover" differs between pronghorn and mule deer. For example, cover for mule deer may be a draw vegetated with tall, dense sagebrush, a pile of rocks, or a thicket of large shrubs or trees. The lee sides of rolling hills or a tall stand of sagebrush along an intermittent stream may constitute cover for pronghorn.

If at all possible, mining operations should avoid critical habitat components. Recontouring should be oriented towards developing a variable topography (see Section 3.3.3.a, Creating Topographic Features), as well as a variety of microenvironments which promote a mixture of vegetation types. Ridges, draws, boulder piles, and highwalls are examples of topographic features which can provide cover.

Reclamation practices suggested for pronghorn (Wyoming Game and Fish Department 1976; Autenrieth 1978) include:

- o Avoid the destruction of natural stands of taller browse, disruption of the shrub-grassland mosaic, and the destruction of fawning areas.
- o Restructure mined areas into gentle, rolling slopes.
- o Reclaim the area to resemble a shrubsteppe grassland. The reseeding mixtures should include important native forb and browse species. The mixture should provide both cover and a variety of preferred food items.
- o If the postdevelopment land use is agricultural crop production, restrict field sizes and intersperse them with strips of native vegetation.
- o Regulate domestic livestock use on reclaimed land to promote an ecological succession that will benefit pronghorn.

Reclamation practices suggested for mule deer (Wyoming Game and Fish Department 1976) include:

- o Where possible, avoid the destruction of rimrocks, rock piles, and dense shrub stands important as winter cover and fawning areas.
- o During recontouring, minimize leveling disturbed areas. Topographic undulations provide environmental variability that encourages the establishment of a mixture of vegetation types. Modify high walls, boulder piles, and gullies only to enhance revegetation efforts. In this region, deer could not survive critical winter periods without utilizing exposed, southerly slopes and bare, windblown ridges for foraging.

For information on the development of these reclamation practices, refer to applicable BCP's listed in the Table of Contents.

Forage

Big game feeding areas should be protected from development. Where development is unavoidable, the following considerations are suggested when reclaiming disturbed lands (Wyoming Game and Fish Department 1976):

- o Evaluate the area's revegetation potential. Surface mining will alter the biological, physical, and chemical properties of the soil and substrate, potentially changing the natural vegetation suitable for the site.

establish readily and yield forage of satisfactory quality and quantity for pronghorn or mule deer. In Wyoming, pronghorn and mule deer generally consume approximately 75% shrubs, 20% forbs, and 5% grasses, annually (Wyoming Game and Fish Department 1976). These figures vary seasonally with weather conditions, plant composition, and availability.

Browse, particularly sagebrush, is essential on winter ranges (Robinette et al. 1952, Sundstrom et al. 1973). Grasses are mostly eaten during early spring greenup; forbs are an important source of water and may constitute a significant portion of the summer diet (Beale and Smith 1970; Sundstrom et al. 1973).

- o Select a mixture of species, including browse, forbs, and grasses. Plant good quality seed in well prepared sites using adequate rates and/or numbers of seedlings, and satisfactory planting techniques. Frequently, seed collected from the area is better adapted to the site-specific conditions than seed of the same species obtained from other areas.

Refer to appropriate BCP's in this handbook for the technical procedures.

A partial list of forage species readily utilized by pronghorn in Wyoming includes (Wyoming Game and Fish Department 1976):

<u>Browse</u>	<u>Forbs</u>	<u>Graminoids</u>
Wyoming big sagebrush	alfalfa	Sandberg bluegrass
black sagebrush	chickpea milk vetch	prairie Junegrass
saltbush (<i>Atriplex</i>)	dandelion	bluebunch wheatgrass
Douglas rabbitbrush	buckwheat	western wheatgrass
rubber rabbitbrush	yellow sweetclover	dryland sedge
fringed sagewort	woody aster	Indian ricegrass
birdfoot sagewort	penstemon	
greasewood		

A partial list of forage species, readily utilized by mule deer in Wyoming includes (Wyoming Game and Fish Department 1976):

<u>Browse</u>	<u>Forbs</u>	<u>Graminoids</u>
true mountainmahogany	red clover	Idaho fescue
curlleaf mountainmahogany	yellow sweetclover	bluebunch wheatgrass
antelope bitterbrush	dandelion	sedges
Wyoming big sagebrush	buckwheat	
black sagebrush	fireweed willowherb	
rubber rabbitbrush		
serviceberry		
currant		

Many of the same species are listed by Plummer et al. (1968) as major species for restoring big game range in Utah.

MAINTENANCE AND MANAGEMENT

Considerations for the long-term upkeep of those practices suggested in this section are generally minor. Refer to the appropriate BCP for the specific maintenance needs.

LABOR AND MATERIALS

Costs involved in the implementation of those practices recommended in this section are discussed in detail under the specific BCP's.

SOURCES OF INFORMATION

- o State Regulatory Authority
- o Office of Surface Mining
- o State Game and Fish Agencies
- o U.S. Soil Conservation Service
- o U.S. Bureau of Land Management

For addresses, see Appendix A.

References Cited:

- Autenrieth, R. Guidelines for the management of pronghorn antelope. Pages 473-526 In Proc. of the Eighth Biennial Pronghorn Antelope Workshop; 1978. 532 p.
- Baker, T. Antelope movement and migration studies. Wyoming Wildl. 17(10):31-36; 1953.
- Beale, D.; Smith, A. Forage use, water consumption and productivity of pronghorn antelope in western Utah. J. Wildl. Manage. 34:570-582; 1970.

- Plummer, A. P.; Christensen, D. R.; Monson, S. B. . Restoring big game range in Utah. Publ. No. 68-3: Utah Div. of Fish and Game, Salt Lake City; 1968. 183 p.
- Robinette, W. L.; Julander, O.; Gashwiler, J. S.; Smith, J. G. Winter mortality of mule deer in Utah in relation to range condition. J. Wildl. Manage. 16:289-299; 1952.
- Sundstrom, C. Water consumption by pronghorn antelope and distribution related to water in Wyoming's Red Desert. Proc. Antelope States Workshop. 3:39-46; 1968.
- Sundstrom, C. Effects of livestock fences on antelope. Fed. Aid Rept. FW-3-R-16: Wyoming Game and Fish Comm., Cheyenne; 1979. 14 p.
- Sundstrom, C.; Hepworth, W. G.; Diem, K. L. Abundance, distribution and food habits of the pronghorn. Wyoming Game and Fish Comm., Cheyenne: Bull. No. 1Z; 1973. 61 p.
- Wyoming Game and Fish Department. Considerations for wildlife in industrial development and reclamation. Cheyenne, WY; 1976. 65 p.
- Yoakum, J. Pronghorn habitat requirements for sagebrush-grasslands. Proc. Biennial Antelope States Workshop. 6:16-25; 1974.
- Yoakum, J. D. Pronghorn. Pages 102-121 In Schmidt, J. L.; Gilbert, D. L., eds. Big game of North America, ecology and management. Wildlife Management Institute, Washington, D. C.; 1978. 494 p.

4. REGIONAL RECLAMATION PLAN

This section contains discussions on the needs for reclaiming woody draws, ponderosa pine woodlands, and cottonwood drainages on a hypothetical mine site in the Northern Great Plains. These habitats are some of the more important communities for wildlife in this region. The plan illustrates how an operator may incorporate the BCP's contained in this handbook into a sound reclamation program.

A reclamation plan submitted to a regulatory agency requires a set of maps of the mine site, including maps showing the premining topography, predisturbance vegetation, predisturbance soil inventory, recontoured (postmining) topography, the revegetation plan, and revegetation sequence. Figures 4.1-1 to 4.1-3 and 4.2-1 to 4.2-3 are examples of the types of maps contained in reclamation plans. Technical requirements of reclamation plans vary between States, and the operator should consult with the specific State regulatory agency for their particular requirements. Portions of the mine site illustrated can potentially support all three habitats listed above. Examples of seeding mixtures for use in the given habitats are from actual operating mines; however, these serve only as examples of the types of possible mixtures and do not represent any endorsement.

4.1 INTRODUCTION

The Porcupine Mine is presented on the following pages as an example of the reclamation on selected portions of a hypothetical site in the Northern Great Plains. The site is physiognomically representative of portions of this region and typical of one on which surface mining would be employed (Figure 4.1-1).

Current land uses on the site are cattle grazing and wildlife habitat. Soils of the mine site range from alluvial loamy soils and silty clay loams along the intermittent streambed to Shinler soils and shale outcrops (Figure 4.1-2). Six major vegetation types occur on the proposed mine site including woody draws, ponderosa pine woodlands, cottonwood drainages, sagebrush, sagebrush-grassland, and grassland (Figure 4.1-3). Postmining restoration of the former three types will be discussed. (Few woody draw reclamation projects have been submitted or approved for field application. The plan, presented below, was developed by Consolidation Coal Company and is included as a potentially feasible plan, although it would probably require an experimental variance for its implementation.)

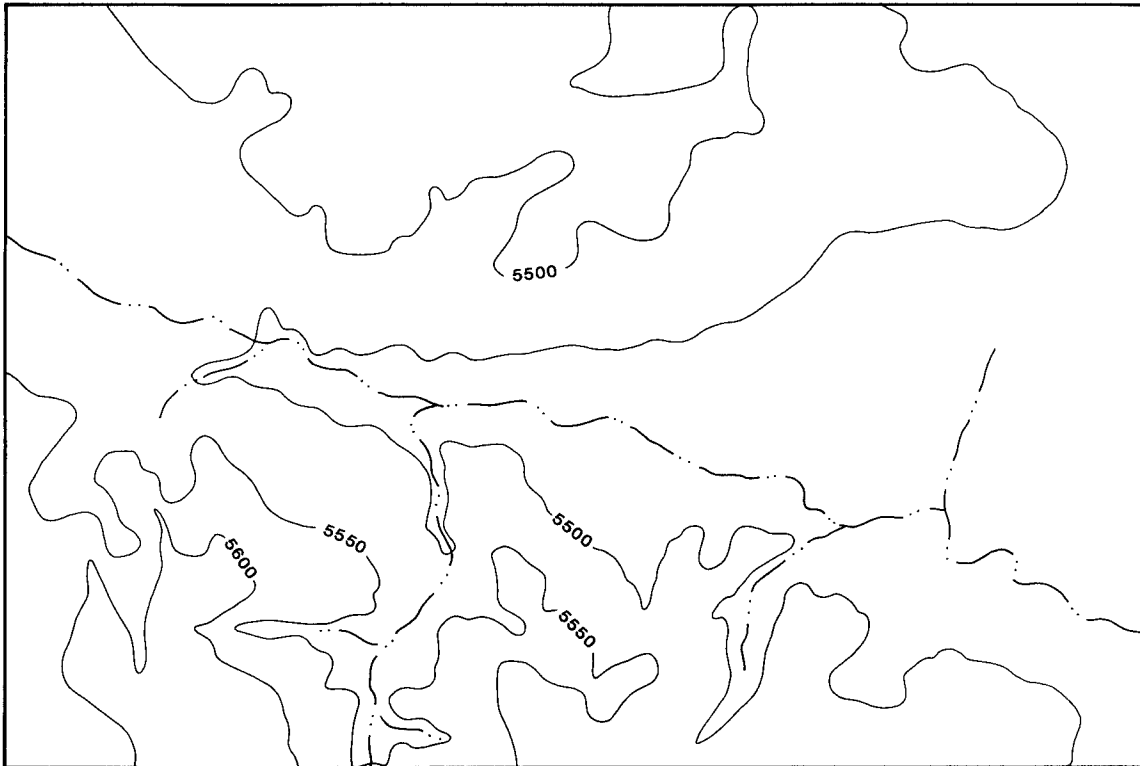
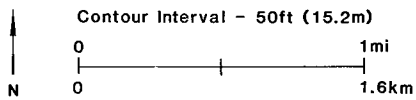

Figure 4.1-1. Premining topography of the Porcupine Mine Site. This map and those in Figures 4.1-2, 4.1-3, and 4.2-1 to 4.2-3 are intended only as general examples of the types of maps (premining topography, vegetation and soils, postmining topography, postmining vegetation, and reclamation sequence) contained in reclamation plans and does not represent any endorsement or criticism of the style, technical content, or intended reclamation goals illustrated.

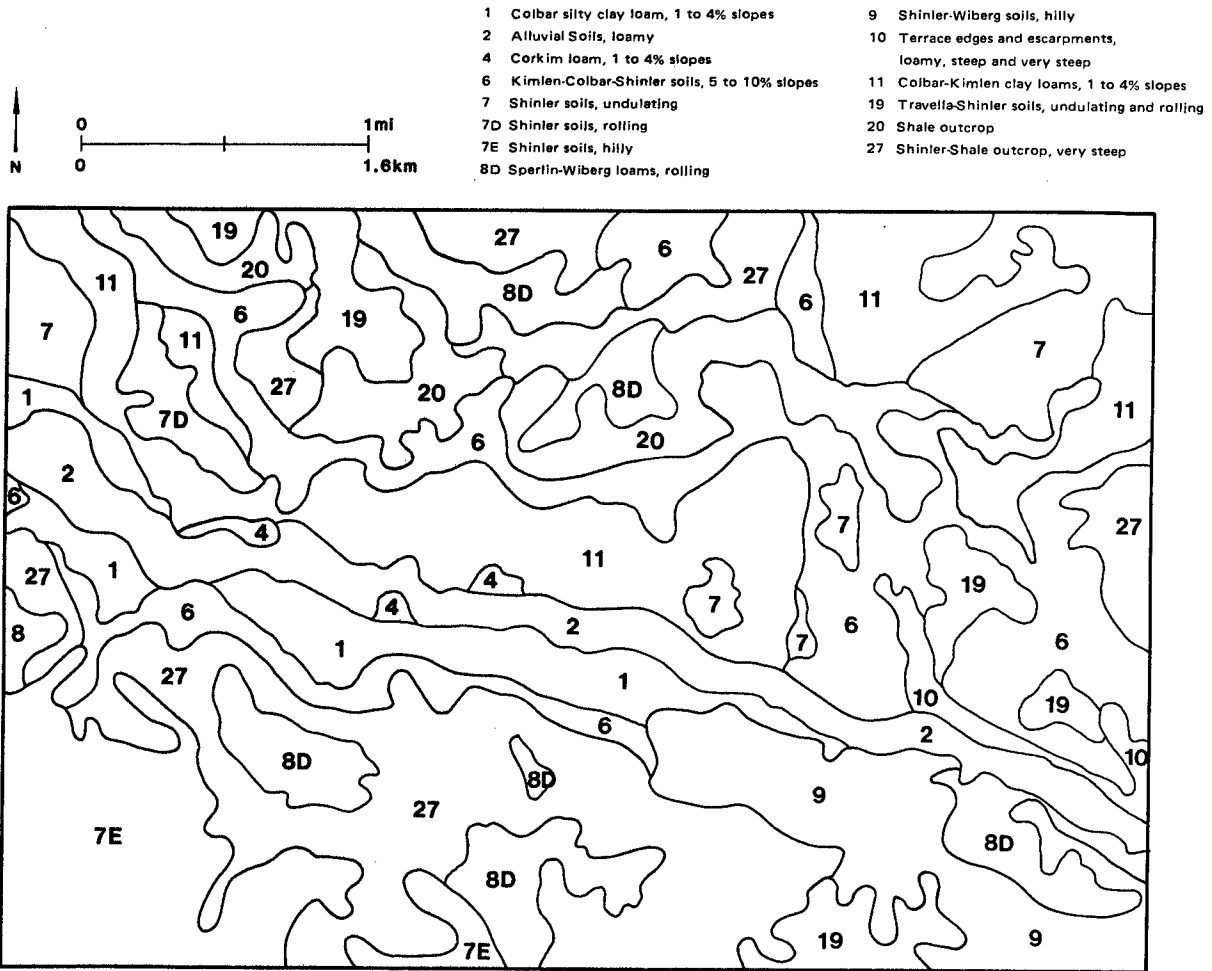

Figure 4.1-2. Premining soils on the Porcupine Mine Site.

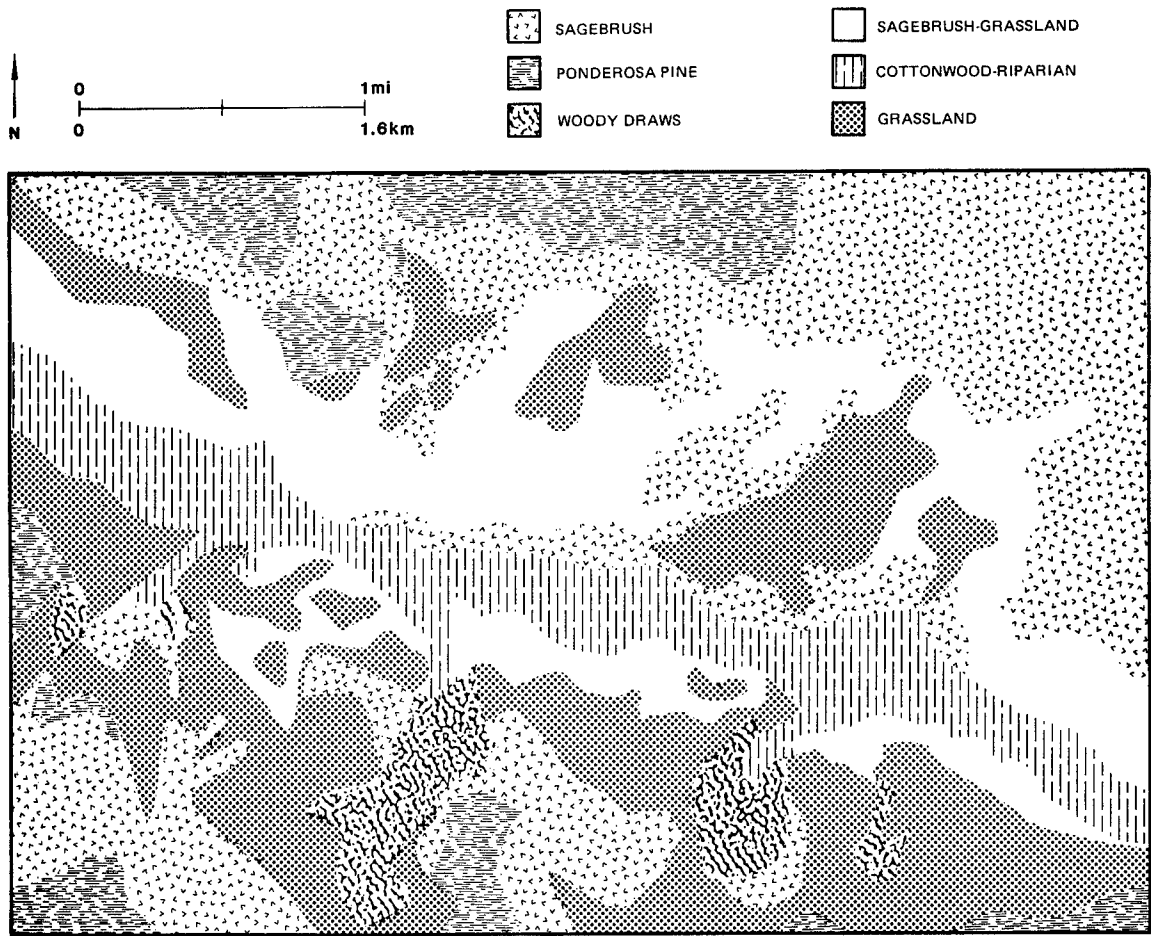

Figure 4.1-3. Premining vegetation on the Porcupine Mine Site.

The postmining land use on the Porcupine Mine Site will be fish and wildlife habitat. Emphasis will be placed on restoring the original vegetation types in patches that will enhance the value of the area for wildlife. The goal of the reclamation and revegetation activities will be to establish landforms, shrub patches, important forage species, cover, and other precursors of a diverse wildlife habitat that will persist following bond release.

4.1.1 Woody Draws

Woody vegetation is a relatively scant, but highly valued resource of the Northern Great Plains. The woody draws in this region vary in species composition, but are characteristically found in the upper reaches of grassland drainages. The shallow, first-order basins often support clumps of silver buffaloberry or western snowberry. Further down a typical draw are such species as common chokecherry, American plum, saskatoon serviceberry, and hawthorn. In wetter drainages, the trees are primarily green ash, American elm, boxelder, and bur oak.

According to Bjugstad (1978), inventories indicate that woody draws occupy 263,000 ha (650,000 acres) or 1% of the 26.3 million ha (65 million acre) Northern Great Plains region. It is clear that, in a region of grassland and shrubs, wooded drainageways offer critical protection for wildlife in both summer and winter. Wooded waterways in the Northern Great Plains offer concentrations of food, shelter, and water and contribute significantly to the habitat diversity necessary for healthy and stable wildlife populations (Orr 1977). The value of these areas far exceeds the small amount of space they occupy.

For both mule deer and white-tailed deer, woody draws account for 50% of their habitat (Bjugstad 1978) and provide important food and cover during the winter. Woody draws are equally important to sharp-tailed grouse which depend on buds and seeds of fleshy hawthorn, Russian olive, silver buffaloberry, western snowberry, chokecherry, and other common shrubs for food during the winter (see Section 3.3.3.h, Maintenance of Sage Grouse and Sharp-tailed Grouse Habitats). Without woody draws, these species could not survive in the region.

Other wildlife species that depend on woody draws for food and/or cover are porcupines, raccoons, weasels, bobcats, and skunks. Birds of prey, such as great horned owls, ferruginous hawks, Swainson's hawks, red-tailed hawks, and golden eagles, use the draws for roosting and nesting. Many nongame birds, such as the belted kingfisher, common snipe, veery, robin, yellow warbler, Bullock's oriole, cedar waxwings, violet-green swallow, and downy woodpecker, would not be found in the region if the woody draws were not available for nesting cover and food. In addition, the edge created by the "stringer" woodlands increases the available habitat.

Although largely subjective, there is considerable evidence that the woodlands of the Northern Great Plains constitute a declining vegetation type (Boldt et al. 1978). Extensive cattle grazing has caused deterioration of many woody stands with no shrubby understory or regeneration of new trees

(Severson and Boldt 1978). Because of the precarious condition of many of the woody draws, reclamation of these areas following mining is a very important.

Consolidation Coal Company designed an extensive reclamation plan for woody draws at the Glenharold Mine near Stanton, ND. Much of the information below pertaining to woody draw restoration was taken from this plan.

4.1.2 Ponderosa Pine Woodlands

Portions of the Northern Great Plains contain extensive homogeneous stands of ponderosa pine on lowland and hilly terrain between 853 and 1,341 m (2,800 to 4,400 ft). Although ponderosa pine is the only forest tree, it occurs in diverse habitat types (Arno 1979). The driest sites have open stands of short trees, 11 to 18 m (35 to 60 ft), with grassland undergrowth of big bluestem, little bluestem, bluebunch wheatgrass, blue grama, and sedge. Conversely, moist north-facing slopes have dense stands of ponderosa pine, from 21 to 29 m (70 to 95 ft) tall, with luxuriant shrub and herb undergrowth, including many species characteristic of the mountain forests to the west. Buffaloberry, kinnikinnik, Oregon grape, arnica, and one-sided wintergreen can be found on these more mesic sites.

The ponderosa pine vegetation type is an important wildlife habitat. At the Westmoreland Absaloka Mine in southeastern Montana, for example, wildlife studies indicate extensive use of ponderosa pine habitat by mule deer, white-tailed deer, and turkey. During the winter of 1975-76, 84% of the mule deer observed on the mine property were in the ponderosa pine forests. Other animals using ponderosa pine habitat include coyotes, bobcats, raccoons, striped skunks, long-tailed weasels, and red foxes (Westmoreland Resources 1978).

Birds occupying the ponderosa forests include the common flicker, western wood pewee, black-capped chickadee, great horned owl, screech owl, pinyon jay, house wren, mountain bluebird, solitary vireo, yellow-rumped warbler, evening grosbeak, poor-will, Cooper's hawk, sharp-shinned hawk, and others. This vegetation type is also an important habitat for wild turkeys, especially in the summer (Westmoreland Resources 1978).

The topography often associated with ponderosa pine habitat is rugged and heavily eroded. Coulees, ravines, and ridgetops have pines in varying densities. This rough terrain and the topographic conditions that make it possible for pines to grow are difficult to duplicate.

The best seedbed for pine germination is loose enough so that only a light layer of mineral soil covers the seeds and has sufficient dead needle litter to prevent drying. Germination may be good in heavy litter in years of high rainfall, but without the soil layer, seedlings do not survive because of rapid drying when the rains stop (Alexander 1974). Obviously, these conditions are difficult to establish on newly reclaimed areas. Establishing pines from seed has not been successfully accomplished in this area yet (Westmoreland Resources 1978).

Two mines in southeastern Montana are reclaiming ponderosa pine sites; Western Energy at Colstrip and Westmoreland Absaloka near Harden. Research on ponderosa reclamation is occurring at both mines.

4.1.3 Cottonwood Drainages

Riparian habitats occur along intermittent and permanent drainages and support more diverse and lush stands of vegetation than the adjacent plains. Cottonwoods are the most obvious species in these areas. Other common species include Russian olive, sagebrush, chokecherry, and willows, as well as sedges, grasses, and forbs. This community provides important food, shelter, and breeding areas for the numerous wildlife that inhabit these areas permanently or intermittently. In addition, stream courses are used by game species for escape cover, water supplies, and as movement corridors.

Restoration of stream habitats to their natural state after alteration or damage is time consuming, costly, and difficult to successfully accomplish (Wyoming Department of Game and Fish 1976). Therefore, the best practice is to avoid impacts to riparian systems whenever possible. Methods of avoidance are discussed in detail in Establishment of Buffer Zones, Section 3.2.2.a. When alterations are inevitable, certain practices can be employed to mitigate impacts. Some of these practices have been used at the Coal Creek, Buckskin, and North Rochelle Mines in Wyoming. These are discussed below.

4.2 REGRADING

During the mining operation, the mined area will be backfilled to approximately the original contour, as shown in Figure 4.2-1. Simultaneous to mine development, reclamation will be instituted in order to provide protection to exposed soils on the site. The proposed reclamation sequence is shown in Figure 4.2-3. Backfilling will be done in 1.2-m (4-ft) lifts to ensure the necessary stability and compaction.

The impoundment on the southeastern portion of the mine site (Figure 4.2-1), used as a sediment pond during mining operations, will be cleaned out with a dozer after draining and converted into a permanent impoundment following mining operations. Islands will be created by bulldozer for waterfowl nesting habitat.

The design of the draws in the southern portion of the site will have a significant impact on the survival of trees and shrubs. Narrow, steep-sided drainage ways will be re-created to maximize moisture collection and retention, minimize erosion, and enhance slope stability.

Three types of tree and shrub planting sites will be constructed within each draw: (1) the primary drainage, with slope less than 5% to minimize erosion; (2) side slopes, with benches constructed of spoil material and topsoiled; and (3) secondary drainageways, which feed into the main channel.

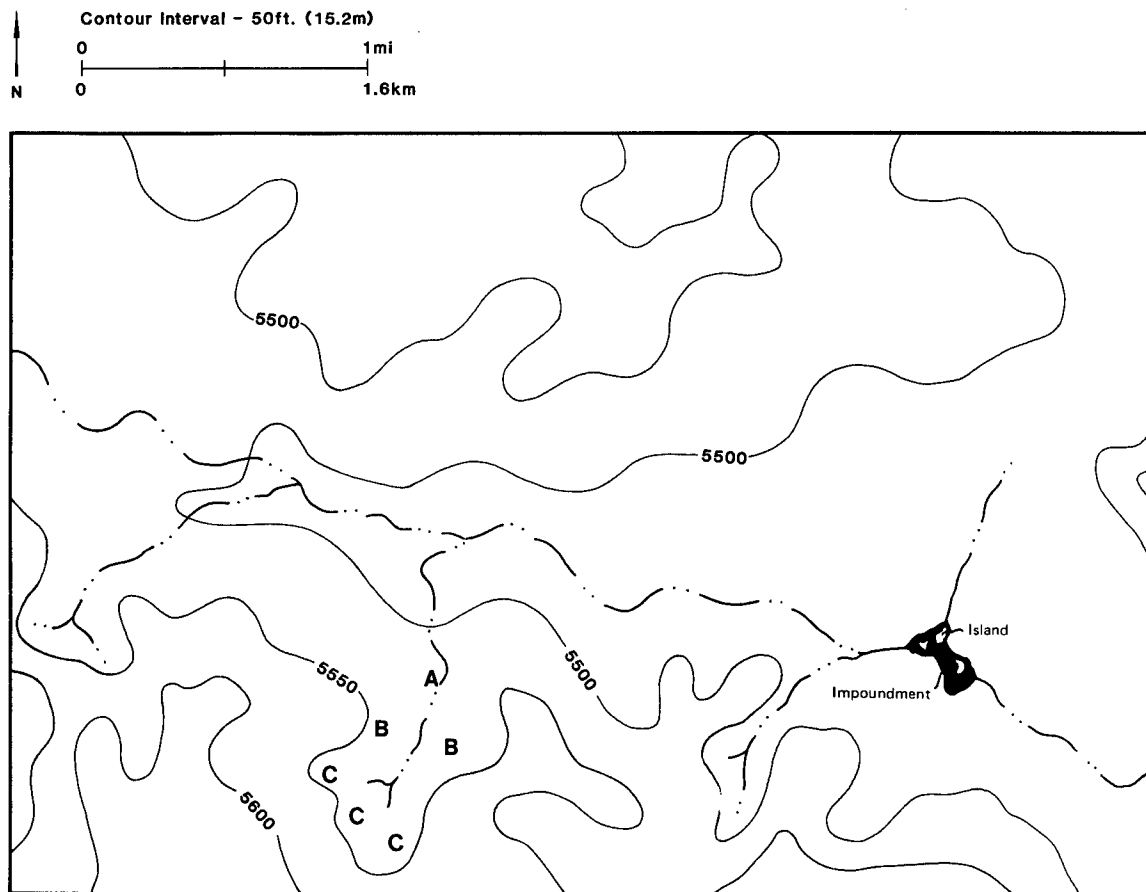

Figure 4.2-1. Recontoured topography of the Porcupine Mine Site showing a primary drainage within a draw (A), the locations of benches on side slopes in the draw (B), and the secondary drainage area at the head of the draw (C).

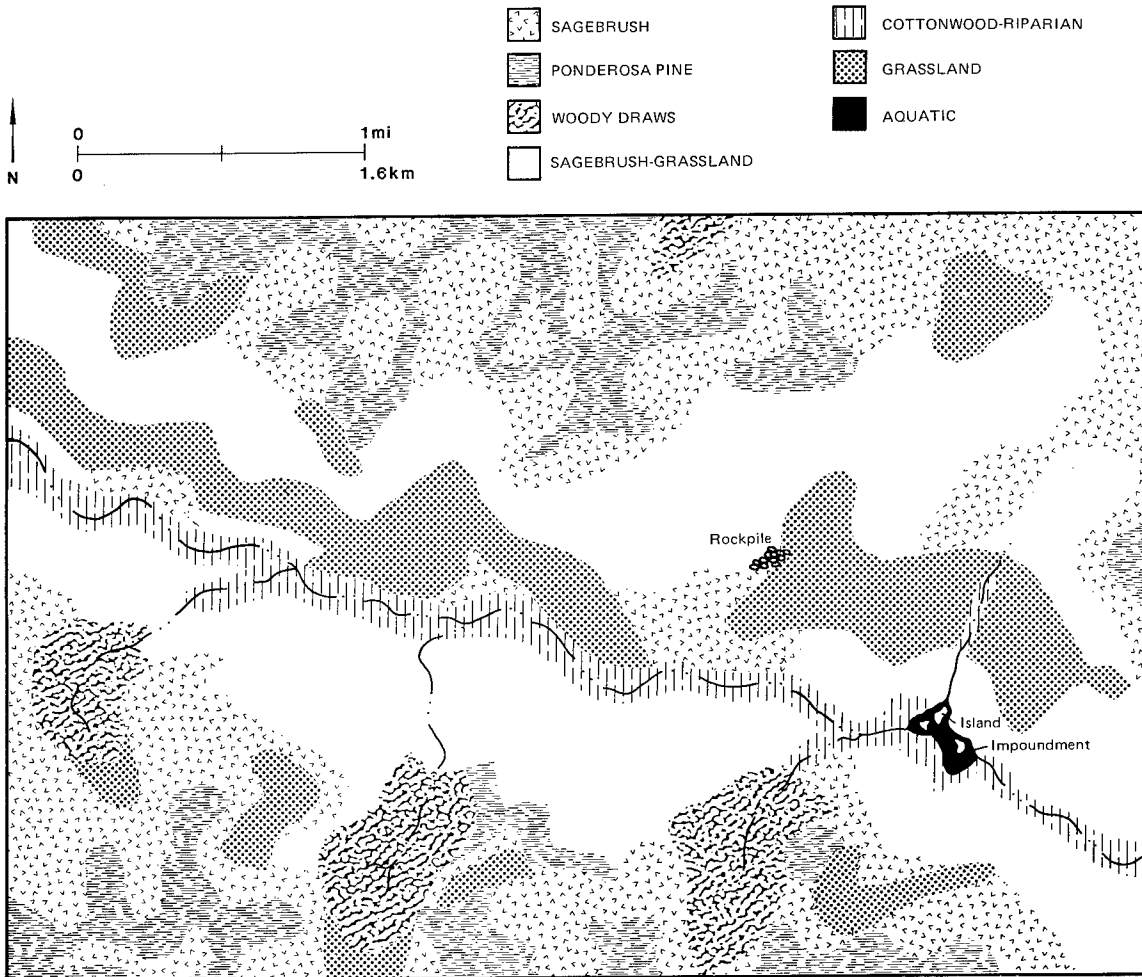

Figure 4.2-2. Postmining vegetation on the Porcupine Mine Site.

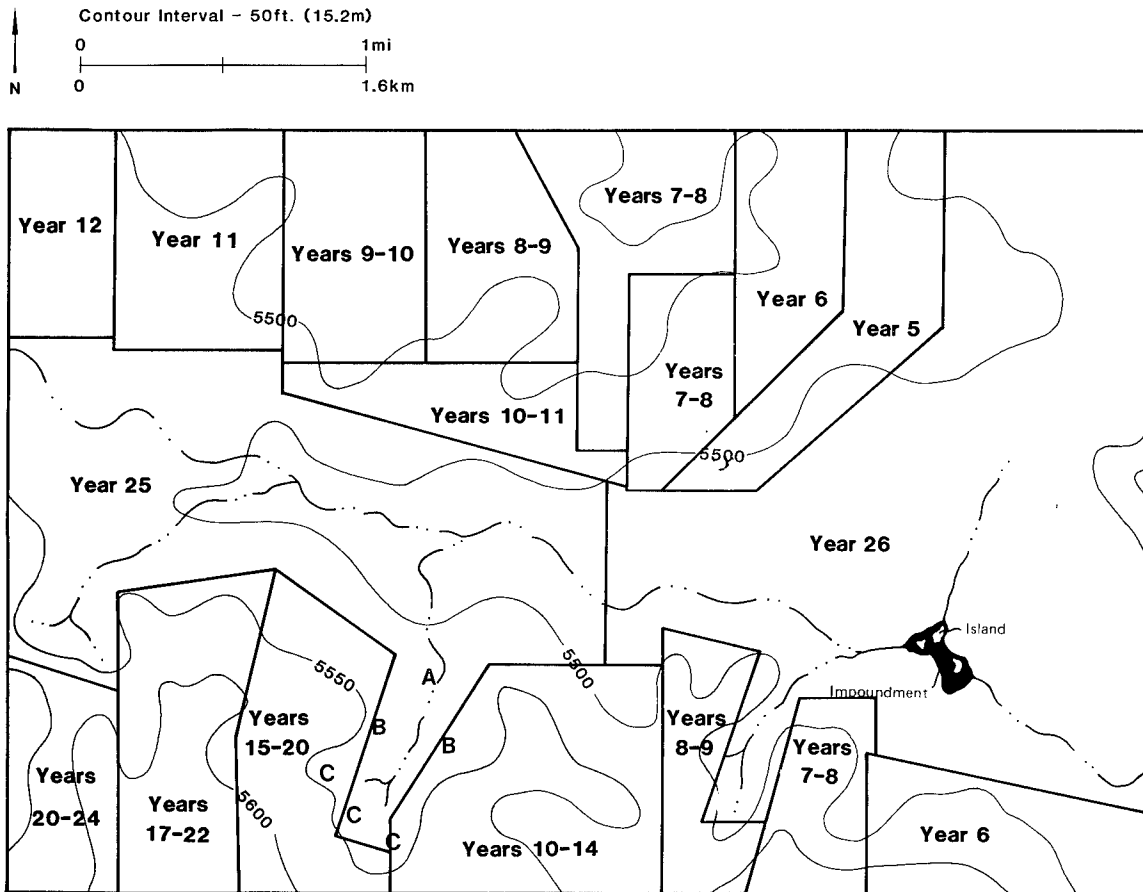

Figure 4.2-3. Proposed reclamation sequence at the Porcupine Mine Site.

4.3 STREAM RESTORATION

The intermittent streambed originally running through the center of the mine site (Figure 4.1-1) will be recut along its former course "cut" following all mining operations on the area (Figures 4.2-1 and 4.2-3). The reclaimed streambed will simulate the original slope, width, depth, natural meanders, and vegetative cover. Log and rock deflectors, large instream rocks, and other structures (see Section 3.3.2.g, Streambed Protection -Gabion Matting and Riprap) will be used as needed to stabilize banks and control erosion during streamflow periods.

4.4 SOIL AND SEEDBED PREPARATION

Soil tests will be made to determine the amount and types (ratios) of fertilizer needed, if any. If phosphorus is needed, it will be broadcast onto the plowed ground and then disked into the soil, before seeding. Nitrogen, if needed, will be applied at the time of seeding in the spring, or, if fall seeding is done, nitrogen application will occur after germination in the spring. Streamside areas will be plowed or disked the summer before planting and nitrogen fertilizer applied. (The Fertilization BCP, Section 3.3.1.b, elaborates on these procedures.)

For reclaiming ponderosa pine plots, topsoil will be hauled directly from an area where ponderosa pine were growing to preserve the natural seed source and any associated mycorrhizae that would aid seedling survival. The best topsoil is a fine, well drained, sandy loam (Dave Simpson, Westmoreland Resources, pers. comm.). (For more specific information on soil handling and amendments, consult General Procedures Section 3.2.1.a, and Selected Placement of Spoils and Topsoil, Section 3.2.1.b)

The slopes of draw benches will be ripped to a depth of 20.3 to 30.5 cm (8 to 12 in) along the contours. The bottom of the draws will receive similar treatment. Topsoil will be placed on the overburden, left in a roughened condition to increase water infiltration, and then disked immediately prior to seeding. (Seedbed preparation is discussed in more detail under Water Conservation, Section 3.3.1.g, and Seeding, Section 3.3.1.c.)

4.5 REVEGETATION AND MANAGEMENT

4.5.1 Cottonwood Drainages

Revegetation along streams serves to prevent erosion of stream banks as well as to provide habitat for many wildlife species. Diverse plant types will be planted, consisting of grasses, forbs, sedges, and trees. The seed mixture proposed for streamside areas is detailed in Table 4.5-1. The shrub and tree seedling transplant mixture is listed in Table 4.5-2. Stream banks will be back sloped during vegetation restoration (Wyoming Department of Game and Fish 1976).

Table 4.5-1. Streamside Seed Mixture (from Shell Oil Company 1981).

Growth Habit	Common Name	Kilograms of Pure Live Seed Per Hectare (lbs/acre)		Number of Seeds Per 0.4 ha (acre)
Grass	Western wheatgrass	3.1	(3.50)	441,000
Grass	Slender wheatgrass	0.9	(1.00)	160,000
Grass	Blue grama	1.3	(1.50)	1,066,500
Grass	Canada wildrye	0.9	(1.00)	106,000
Grass	Basin wildrye	0.9	(1.00)	95,000
Grass	Prairie junegrass	0.9	(1.00)	500,000
Grass	Kentucky bluegrass	1.8	(2.00)	4,400,000
Grass	Green needlegrass	0.9	(1.00)	181,000
Forb	Western yarrow	0.04	(0.05)	56,750
Forb	Prairieconeflower	0.2	(0.20)	140,000
Forb	Scarlet globemallow	0.04	(0.05)	25,000
Forb	Prairie thermopsis	0.04	(0.05)	1,500
Forb	American vetch	0.04	(0.05)	1,250
Shrub	Wood's rose	0.9	(1.00)	50,000
Total		11.96	(13.40)	7,224,000

Table 4.5-2. Streamside Seedling Transplant Mixture (from Shell Oil Company 1981).

Growth Habit	Common Name	Seedling Number
Shrub	Big sagebrush	20/0.4 ha (acre)
Shrub	Skunkbrush sumac	40/0.4 ha (acre)
Shrub	Wax currant	40/0.4 ha (acre)
Shrub Total		100/0.4 ha (acre)
Tree	Russian olive	5/0.4 ha (acre)
Tree	Plains cottonwood	5/0.4 ha (acre)
Tree Total		10/0.4 ha (acre)

Cottonwood trees are particularly suitable for this area since they are fast growing and are preferred roost sites for eagles. Studies have shown that wintering eagles prefer to perch on trees within 30 m (100 ft) of a riverbank (Steenhof 1976). Eagles prefer perches bordered by open areas and at least one edge type. The distribution of postmining vegetation types will provide these types of habitats. (For a further discussion on the creation of edge, see Section 3.3.3.b, Planting Patterns to Increase Wildlife Diversity)

Russian olive is useful for wildlife cover and as a food source. This tree can withstand considerable grazing pressure and its leaves and fruits persist through late fall.

a. Planting. Methods of seeding, periods for seeding, and discussions on the amount of seed required are contained in Section 3.3.1.c, Seeding. Techniques for increasing reclamation success have also been discussed in Section 3.3.1.b, Fertilization, and Section 3.3.1.g, Water Conservation.

The areas to be planted in trees will be pitted with a disc gouger to leave relatively large basins for concentrating extra water. Native and nursery grown shrubs will be transplanted in modified front end loaders. The proportion of native to nursery-grown shrubs will depend on the availability of transplant stock. (These techniques are discussed in detail under Transplanting Native Vegetation, Section 3.3.1.d, and Transplanting Nursery Grown Plants, Section 3.3.1.e).

Hand planting of seedling trees and shrubs may also be used. The following guidelines will be employed for hand planting cottonwood seedlings (after McKnight 1970).

- o All sites will have proper soil conditions and adequate moisture during the growing season (i.e., a water table 1 to 2 m [3 to 6 ft] below the surface).
- o The site will be plowed or disked the summer before planting and nitrogen fertilizer applied as specified above.
- o Fifty-centimeter (20-in) cuttings will be collected from one- to three-year-old cottonwoods just before the growing season and just prior to planting. Cuttings 1.3 to 2.5 cm (0.5 to 1.0 in) in diameter will be used from a stock source within 325 km (200 mi) of the planting site. Crooked, split, or peeled sections of stems will be discarded.
- o Cuttings will be wrapped in wet burlap and soaked for three days.
- o Cuttings will be planted as early as possible in the growing season by inserting them in 2.5 cm (1 in) diameter holes 45 cm (18 in) deep, leaving 5 cm (2 in) exposed. Holes will be spaced on a 3.7 m by 3.7 m (12 ft by 12 ft) grid.

- o Hand-held gasoline-powered weed eaters will be used to control weeds around shrubs and trees, if necessary. Care will be taken to avoid damaging the shrubs and trees. Weeding in this manner will be conducted twice during the growing season, mid-June and late July. Other methods of weed control may also be used (see Pest Control, Section 3.3.1.j). Trees will be thinned by transplanting in alternate rows when tree diameters reach 20 cm (8 in). Trees removed will be replanted in other suitable sites. Only the smallest trees will be removed in a second thinning when diameters reach 30 cm (12 in).

The natural topography of streambanks will provide suitable locations for the establishment of windbreaks and snowbreaks (see Creating Wind and Snowbreaks for Winter Wildlife Protection, Section 3.3.3.c).

4.5.2 Woody Draws

a. Species selection. The seed mixtures and woody, nursery-grown species, developed by Consolidated Coal Company for recreating woody draws at the Glenharold Mine in Stanton, ND, will be used on the side slopes, secondary drainages, and primary drainages in the southern portion of the Porcupine Mine (Figure 4.2-2). Tables 4.5-3 through 4.5-7 give detailed information on the species adaptation, usefulness to wildlife, and amount of seed required (for species to be seeded). (Additional information on the selection of revegetation species, their site applicability, value for wildlife, and other characteristics is discussed in Use of the Plant Information Network [PIN] to Aid in Selection of Revegetation Plants, Section 3.3.3.a).

b. Seeding. Seeding will occur before the period of greatest expected precipitation, late April to late May. Seed will be drilled using seed boxes specially equipped to handle different sizes and weights of seed. A culti-packer following the drill will cover the seed and pack the soil. Sites too steep or rocky for drilling will be broadcast seeded by hand or with a mechanical spreader at twice the drilling rate. The seeded sites will be mulched with hay at a rate of 1.8 MT (2 tons)/0.4 ha (acre) and crimped to anchor the mulch to the soil. This is discussed in more detail under Seeding (Section 3.3.1.c) and Mulching (Section 3.3.1.h).

c. Planting techniques. Bare root and containerized stock will be planted with portable, powered planting augers as specified in Transplanting Nursery Grown Plants (Section 3.3.1.e). A fertilizer tablet will be dropped into each hole while planting the seedlings. These tablets provide all of the nitrogen, phosphorus, and potash needed by the seedling for two years. Woody planting locations will occur in the primary drainageways, secondary drainageways, and on the benches which are positioned on the north- and east-facing slopes. Large tree stock of green ash, boxelder, aspen, and American elm will be removed from areas scheduled for disturbance and transplanted with a front end loader modified with a transplant bucket (Transplanting Native Vegetation, Section 3.3.1.d). These trees will be placed in the primary drainageways, draining north from the southern portion of the area (Figure 4.2-2), where the most moisture is available. All species will be matched to favorable micro-sites as indicated in Table 4.5-7.

Table 4.5-3. Species to be Used in the Initial Seeding and Soil Stabilization Process for Side Slopes and Secondary Drainages.

Common Name	Seeds/0.45 kg (1b)	Seeding Rate PLS kg/ha (lbs/acre)	Seeding Rate PLS/m ² (ft ²)	Percent Germina- tion	Percent PLS
Green Needlegrass	181,000	2.2 (2.5)	111.8 (10.4)	70	65
Blue grama	711,000	1.3 (1.5)	263.4 (24.5)	60	50
Buffalograss	42,000	3.6 (4)	40.9 (3.8)		
Western wheatgrass	126,000	2.2 (2.5)	77.4 (7.2)	80	85
Pubescent wheatgrass	90,000	2.7 (3)	66.7 (6.2)	85	90
Sideoats grama	143,000	3.6 (4)	140.9 (13.1)	60	60
Streambank wheatgrass	160,000	1.8 (2)	78.5 (7.3)	90	95
Alfalfa	210,000	0.4 (0.5)	25.8 (2.4)	90	95
Western snowberry	74,400	3.6 (4)	73.1 (6.8)	-- ¹	-- ¹
Shadscale saltbush	65,000	2.7 (3)	48.4 (4.5)	--	--
Rubber rabbitbrush	335,000	0.9 (1)	82.8 (7.7)	--	--
Big Sagebrush	2,576,000	0.4 (0.5)	317.2 (29.5)	--	--
Wood's rose	50,000	2.7 (3)	36.6 (3.4)	--	--
Buffaloberry	41,000	0.9 (1)	9.7 (0.9)	--	--
Chokecherry	4,790	0.9 (1)	1.1 (0.1)	--	--

¹Data not available.

Table 4.5-4. Adaptation Matrix for Species to be Used in the Initial Seeding and Soil Stabilization Process of Side Slopes and Secondary Drainages.

Common Name	Sod-Former vs Bunchgrass		Soil Texture Adaption	Drought Tolerance	Tolerance To Salt	Miscellaneous Comments
	Bunchgrass	Seasonality				
Green needlegrass	Bunchgrass	Cool	Medium to clayey texture	Fair to Good	Fair	Delayed germination, adapted for seeding on a wide range of soil textures, but is more abundant on clayey and clay textured soils. May produce higher yields than other grasses under low fertility; high value to songbirds and small rodents. North Dakota developed cultivars available.
Western wheatgrass	Sod-former	Cool	Medium to clayey textures	Good	Very good	Slow germination; spreads rapidly; long lived; moderately shade tolerant; produces seed in June and goes dormant in midsummer; most important grass in wetter regions of the mixed prairie; can withstand silt deposition; a highly rhizomatous species, used extensively in the West for the reclamation of disturbed lands, recommended for erosion control in the 31-cm (12-in) precip. zone; generally adapted to short grass and mid-grass prairies, aspen-sagebrush foothills, pinyon-juniper and saline-alkaline bottomland sites in the Northern Great Plains.
Pubescent wheatgrass	Sod-former	Cool	All	Fair to Good	Fair	Tolerant to moderate sodium levels; less drought tolerant than standard crested wheatgrass or Russian Wildrye but more so than intermediate wheatgrass; tolerance to adverse conditions makes it good for conservation and soil stabilization; adapted to low fertility areas; provides nesting and escape cover for birds and forage for big game; recommended for the 31- to 46-cm (12- to 18-in) precipitation zone; generally adapted to mid-grass and aspen sites.

Table 4.5-4 (continued)

Common Name	Sod-Former vs Bunchgrass	Seasonality	Soil Texture Adaption	Drought Tolerance	Tolerance To Salt	Miscellaneous Comments
Sideoats grama	Bunchgrass-Sod-Former	Warm	All	Fair to Good	Poor to Fair	Has potential for revegetating road cuts, mined areas, construction cuts and fills; can tolerate low fertility; recommended for erosion control, grazing, and wildlife plantings in the desert, semi-desert and upland climatic zones; generally adapted to short-grass and mid-grass prairies in the Northern Great Plains.
Streambank wheatgrass	Sod-Former	Cool	All	Good	Fair	Quick germination; moderate shade tolerance; vigorous sod-former; grows naturally on hillsides and on streambanks; good for droughty soil stabilization; produces well on areas with 15 cm (6 in) or more of rainfall; may be of use on steep slopes; often overlooked for dry site planting because of its name; generally adapted to foothill, mountain, and aspen sites in the Northern Great Plains.
Alfalfa	--	--	All	Fair	Fair	Good germination; good growth rate; strong tap root; moderately shade tolerant; widely used in range, pasture, and revegetation mixtures; vigorous plant which grows readily on adapted sites; the variety "Ranger" is a good performer under dryland conditions; valuable to waterfowl.
Western snowberry	--	--	All	Good	Fair	Thicket-forming deciduous shrub; used for wildlife plantings and erosion control.
Shadscale saltbrush	--	--	All	Excellent	Excellent	Occurs on a variety of soils, both saline and alkaline; valuable browse plants, has been used for erosion control.

Table 4.5-4 (concluded)

Common Name	Sod-Former vs Bunchgrass		Seasonality	Soil Texture Adaption	Drought Tolerance	Tolerance To Salt	Miscellaneous Comments
	--	--					
Rubber rabbitbrush	--	--	--	Varies w/ subspecies	Good	Varies w/ subspecies	Vigorous seedlings; rapid growth once established; aggressive pioneer species; spreads rapidly from seeds; has been seeded successfully w/forbs because it has a short stratification period (germinates quickly); good soil stabilizer.
Buffaloberry				All	Excellent	Excellent	Nitrogen fixing capability; high value to both game and non-game species; used for food and cover, suckering common relative to soil nutrition and water conditions. Highly tolerant of cold, drought and alkali soil conditions
Chokecherry				All	Excellent	Fair	Tall shrub, provides excellent food and cover for both game and non-game species.
Big sagebrush	--	--	--	Best on Medium to Clayey Textures	Good	Fair	Good germination and persistence; vigorous seedlings, good growth rate; good rate of natural spread; wide range of adaptation; long-lived; important to many small and big game species; has been seeded successfully with adapted grasses on arid lands; valuable for range restoration and soil stabilization.
Wood's rose	--	--	--	All	Good	Fair	Deciduous shrubs; important wildlife species; rose thickets provide excellent nesting or escape cover for many kinds of birds and small mammals.

Table 4.5-5. Species to be Used in the Initial Seeding and Soil Stabilization Process for Primary drainages.

Common Name	Seeds/0.45 kg (1b)	Seeding Rate PLS kg/ha (lbs/acre)	Seeding Rate PLS/m ² (ft ²)	Percent	
				Germina- tion	Percent PLS
Canada wildrye	106,000	2.7 (3)	78.5 (7.3)		
Orchardgrass	540,000	1.3 (1.5)	100 (18.6)	85	85
Perennial ryegrass	247,000	0.9 (1)	61.3 (5.7)	-- ¹	-- ¹
Big bluestem	130,000	2.7 (3)	96.8 (9)	80	40
Intermediate wheatgrass	93,000	2.7 (3)	68.8 (6.4)	85	90
Slender wheatgrass	160,000	1.8 (2)	78.5 (7.3)	85	95
Streambank wheatgrass	160,000	0.9 (1)	78.5 (7.3)	90	95
Switchgrass	389,000	0.9 (1)	95.7 (8.9)	75	95
Tall wheatgrass	79,000	1.8 (2)	38.7 (3.6)	85	95
Western wheatgrass	126,000	1.8 (2)	62.4 (5.8)	80	85
Alfalfa	210,000	0.9 (1)	51.6 (4.8)	90	95
Serviceberry	45,000	2.7 (3)	33.3 (3.1)	--	--
Western snowberry	74,400	3.6 (4)	73.1 (6.8)	--	--
Wood's rose	50,000	3.6 (4)	48.4 (4.5)	--	--
Chokecherry	4,790	0.9 (1)	1.1 (0.1)	--	--

¹Data not available.

Table 4.5-6. Adaptation Matrix for Species to be Used in the Initial Seeding and Soil Stabilization Process of Primary Drainages.

Common Name	Sod-Former vs Bunchgrass	Seasonality	Soil Texture Adaption	Drought Tolerance	Tolerance To Salt	Miscellaneous Comments
Canada wildrye	Bunchgrass	Cool	All	Fair	Good	Vigorous seedlings; produces by tillers as well as seed; common on prairie sites; produces ground cover rapidly; recommended for seeding in warm season mixtures because it provides fall and spring pasture.
Intermediate wheatgrass	Sod-Former	Cool	All	Fair	Fair	Good seedling vigor; moderate longevity; moderately shade tolerant; most productive on mesic sites; provides nesting and escape cover for birds; big game utilize forage; recommended for erosion control in the 38-cm (15-in) precipitation zone; generally adapted to the mid-grass, aspen, and mountainous areas in the Northern Great Plains.
Orchardgrass	Bunchgrass	Cool	All	Poor	Fair	Good germination; vigorous seedlings; good growth rate, long-lived; high shade tolerance; starts growth in early spring; responds readily to fertilizer; highly palatable, valuable pasture and forage species; good wildlife species; can do well on poor soils.
Perennial ryegrass	Bunchgrass	Cool	Medium to Clayey Textures	Poor	Fair	Quick germination makes this species useful for erosion control; short-lived.
Slender wheatgrass	Bunchgrass	Cool	All	Good	Good	Seedlings vigorous and fast growing; short-lived, green throughout the summer; called "insurance grass" because of its quick germination and growth abilities, recommended for the 38- to 64-cm (15- to 25-in) precipitation zone; generally adapted to aspen and mountainous sites in the Northern Great Plains.

Table 4.5-6 (continued)

Common Name	Sod-Former Vs Bunchgrass		Seasonality	Soil Texture Adaption	Drought Tolerance	Tolerance To Salt	Miscellaneous Comments
	Sod-Former	Bunchgrass					
Streambank wheatgrass	Sod-Former	Bunchgrass	Cool	All	Good	Fair	Quick germination; vigorous sod-former; good longevity; grows naturally on hillsides and on streambanks
Switchgrass	Sod-Former	Bunchgrass	Warm	All	Fair	Fair	Long-lived; found with the bluestems; most common in central lowlands of the Great Plains; tolerates low fertility soils; widely seeded in warm season mixtures on mesic sites; used in grassed waterway or terrace outlet mixtures; forms a dense sod.
Tall wheatgrass	Sod-Former	Bunchgrass	Cool	All	Fair	Very Good	Moderate to high seedling vigor; good growth rate; late maturing, medium longevity; most salt tolerant of the wheatgrasses; has been established on soils with a pH of 10; tolerant in clayey, salty soils; tolerant to sodic conditions; produces a great root mass to aid in reclamation and stabilization; good wildlife cover plant; seeds stand on stalk and provide emergency wildlife food in the winter; generally adapted to saline-alkali bottomlands and some higher elevation vegetation types in the Northern Great Plains.
Kentucky bluegrass	Sod-Former	Bunchgrass	Cool	All; Prefers loamy soils	Fair	Fair	Vigorous seedlings; forms solid turfs on sod; has good reclamation potential, esp. in areas of sufficient moisture.
Big bluestem	Sod-Former	Bunchgrass	Warm	Sandy Loam	Fair	Poor-Fair	Can be used for erosion control in drainages. Leafy characteristics provide excellent wildlife cover; livestock prefer big bluestem to other grasses.
Western wheatgrass	Sod-Former	Bunchgrass	Cool	Medium to Clayey Textures	Good	Very Good	See Table 4.5-4.

Table 4.5-6 (concluded)

Common Name	Sod-Former vs Bunchgrass		Seasonality	Soil Texture Adaption	Drought Tolerance	Tolerance To Salt	Miscellaneous Comments
Alfalfa	--	--	--	All	Fair	Fair	See Table 4.5-4.
Serviceberry	--	--	--	Best on Medium to Clayey Textures	Fair	Poor	Good germination and persistence; moderate growth rate; easily planted; at maturity, this species can produce a large amount of valuable wildlife forage in years of low rainfall. Grows on a variety of sites from dry, rocky slopes to deep moist soils. Medium range restoration and soil stabilization values; provides high quality wildlife forage and is a preferred winter forage for big game; recommended for the 38-cm (15-in) precipitation zone.
Western snowberry	--	--	--	All	Good	Fair	See Table 4.5-4.
Wood's rose	--	--	--	All	Good	Fair	See Table 4.5-4.
Chokecherry	--	--	--	All	Excellent	Fair	See Table 4.5-4.

Table 4.5-7. Species Selected for Woodland Revegetation.

Common Name	Tolerance To Drought	Tolerance To Cold	Planting Site	Miscellaneous Comments
Boxelder	Good	Excellent	Primary drainages, benches, and secondary drainage	Common along streams and small drainages in ND. Prefers mesic sites; has moderately high utilization values for song birds and big game animals.
Russian olive	Excellent	Excellent	Primary drainages, benches, and secondary drainage	Adapted to extremely alkaline soils, has performed well on spoils; has a high utilization value for song birds.
Green ash	Excellent	Excellent	Primary and secondary drainages, and benches	Hardy species; adapted to reclamation plantings.
Creeping juniper	Excellent	Excellent	Benches and secondary drainages	Main stems usually creeping on ground; forms dense mat on buttes, hills, and slopes. Has moderately high utilization values for small rodents, song birds, upland game birds and big game.
Rocky Mtn. juniper	Excellent	Excellent	Benches and secondary drainages	Adapted to reclamation plantings; has moderately high utilization value for small rodents, song birds, upland game birds, and big game.
Cottonwood	Low Tolerance	Excellent	Primary and secondary drainages - few on lower benches	Pioneer plant - occurs naturally on disturbed sites - short-lived except in areas of adequate moisture; salt tolerant.
Willow	Low Tolerance	Excellent	Primary and secondary drainages	Pioneer plant - occurs naturally in low wet areas; moderately tolerant to salt.
Native plum	Fair	Excellent	Primary drainages, secondary drainages and benches	Should be planted in swales between slopes; adapted to reclamation plantings; has high utilization values for small rodents, upland game birds and small game.
Bur oak	Excellent	Excellent	Primary drainages, secondary drainages and benches	Frequent to common on higher wooded ground in ND; small to medium size tree; has high utilization value to small game animals.

Table 4.5-7 (continued)

Common Name	Tolerance To Drought	Tolerance To Cold	Planting Site	Miscellaneous Comments
Siberian elm	Excellent	Excellent	Primary drainages, secondary drainages and benches	Prefers mesic sites; is of moderately high importance to big game, game birds, song birds, and small rodents.
Aspen	Fair	Excellent	Primary drainages and around ponds	Common along streams, creek bottoms, and sheltered areas in ND. Has a well developed rhizome system.
Serviceberry	Good	Excellent	Primary drainages, secondary drainages, and benches	At maturity, this species can produce a large amount of valuable wildlife forage in years of low rainfall; grows on a variety of sites from dry rocky slopes to deep, moist soils.
Skunkbrush	Excellent	Excellent	Benches and secondary drainages	Has had excellent success in reclamation in MT.
Silverberry	Excellent	Excellent	Benches and secondary drainages	High survival rates have been noted on reclaimed land in MT.
Chokecherry	Good	Good	Benches, secondary and primary drainages	Also has exhibited high survival rates in MT reclamation.
Western wild rose	Excellent	Excellent	Benches, secondary and primary drainages	Has exhibited high survival rates and good growth rates on reclaimed lands.
Buffaloberry	Good	Excellent	Benches, secondary and primary drainages	Has much promise as a quick soil stabilizer; spreads rapidly; good wildlife species.
Common snowberry	Good	Excellent	Benches, secondary and primary drainages	Has much promise as a quick soil stabilizer; spreads rapidly; good wildlife species.
Western snowberry	Excellent	Excellent	Benches, secondary and primary drainages	Rapid spreader; has promise as a quick soil stabilizer; has high utilization values for big game, song birds, and small rodents.

Table 4.5-7 (concluded)

Common Name	Tolerance To Drought	Tolerance To Cold	Planting Site	Miscellaneous Comments
Spiny saltbrush	Excellent	Excellent	Benches and secondary drainages	Good for alkaline and saline soil stabilization; has the ability to survive and grow satisfactorily in a broad range of environments.
Rubber rabbitbrush	Good	Excellent	Benches and secondary drainages	Good soil stabilizer; used for erosion control and wildlife plantings in the semi-desert, upland and mountain zones.
Big sagebrush	Good	Excellent	Benches and secondary drainages	Recommended for erosion control and wildlife plantings; generally adapted to short grass prairie in Northern Great Plains.
Winterfat	Good	Excellent	Benches and secondary drainages	High range restoration and soil stabilization values; utilized by many small and some large game animals.

d. Planting rate and timing. Seedlings will be planted at 1-m (3-ft) intervals so that each seedling will be at least 1 m from other seedlings in every direction. There will be approximately 11,952 seedlings/ha (4,839/acre). Plantings will occur in the spring after the soil has thawed; by June 1st if possible. Some slopes may have to be stabilized with perennial grasses before planting seedlings or transplanting trees (see Transplanting Nursery Grown Plants, Section 3.3.1.e).

e. Weed control. Weed control will be aimed at reducing competition from grasses. A biodegradable paper disc will be placed around each seedling. These discs are 0.6 m (2 ft) in diameter and 1.3 cm (0.5 in) thick. A slit in the disc makes them easy to apply yet it keeps them from blowing away.

f. Water harvesting. Getting enough moisture to the newly planted woody vegetation will be critical to its survival. Snow pileup will occur when the woody vegetation reaches sufficient height to trap windblown snow, but until that time, snow fences will be used to increase moisture availability. Snow fences will be oriented perpendicular to the prevailing wind to maximize snow pileup. The fences will be spaced at 121-m (400-ft) intervals across east-facing slopes. Mulching and modification of the soil surface may be implemented as required. Details of specific techniques are provided under Water Conservation, Section 3.3.1.g.

4.5.3 Ponderosa Pine Woodlands

a. Seeding - preparatory crops and perennials. There is no Best Current Practice at this time concerning when to plant understory grasses for the ponderosa pine reclamation sites (Figure 4.2-2). The Absaloka Mine planted a winter wheat preparatory crop of 8.9 kg/ha (10 lbs/acre) on the steep slopes for stabilization (see Section 3.3.1.f, Cover Crops/Preparatory Crops) but received a variance for three years from planting a perennial seed mix until the transplanted pines were established. It is uncertain if this is the best practice because of competition from weeds; however, the Porcupine Mine will attempt a similar procedure if an experimental variance can be obtained. (Details of weed control are discussed in Section 3.3.1.j, Pest Control.) More research needs to be conducted on preparatory crops in ponderosa pine forest reclamation. We hope the data generated from revegetation efforts at the Porcupine Mine will provide the required information.

b. Seedling source. Seeds will be collected from nearby stands of mature ponderosa pines, germinated in a nursery, and returned to the disturbed areas as containerized or bare root seedlings for planting. Transplanting of nursery grown seedlings on conducive microsites (Figure 4.2-2) will follow the procedure discussed in detail in Transplanting Nursery Grown Plants, Section 3.3.1.e. The seed source is extremely important in this region because the genetic variability between ponderosa pines growing east or west of the continental divide. George Blake of the University of Montana (pers. comm.) is conducting research at the Western Energy Mine to verify the genetic structure of these local pines.

Since ponderosa pines produce good seed crops only every three to four years, it will be important to collect a substantial number of seeds during the productive years (Alexander 1974).

c. Planting bare root stock. Initial plantings will be with bare root stock planted in early spring so that root establishment can occur before top growth starts. With proper handling of the bare root seedlings, such as having as short a time as possible between digging the seedlings and replanting, survival is expected to be good. However, if the survival rate is less than 50%, containerized stock will be used to supplement the plantings. Details on how to transplant and how to care for seedlings are discussed in Transplanting Nursery Grown Plants, Section 3.3.1.e.

Seedlings will be planted on north-facing slopes and on ridgetops where more moisture is available. An initial watering immediately after planting will help the seedlings survive planting-related stress.

d. Mulch and weed control. A wood shaving mulch will be placed around the seedlings, 0.6 m (2 ft) in diameter and 7.6 cm (3 in) deep. This will help retain moisture and increase seedling success. (A detailed discussion of water harvests and conservation methods needed for seedling success can be found in Water Conservation, Section 3.3.1.g. Weed control will also be accomplished by the use of mulch at this depth around the seedlings. More detail on this method of weed control and other useful methods are discussed in Pest Control, Section 3.3.1.j.

e. Irrigation. A drip irrigation system will be used for one to two years to increase the chance of seedling survival. Drip irrigation can be directed to individual seedlings and reduces the chances of erosion that might occur with a sprinkler system. (For details on the best current irrigation practices, see Section 3.3.1.i, Irrigation.)

In addition, hand-held gasoline-powered weed eaters will be used to clip weeds around the seedlings if this becomes necessary. Weeding in this manner will be done twice during the growing season, mid-June and late July. (Other methods of weed control are discussed in Pest Control, Section 3.3.1.j.)

f. Planting mature vegetation. A transplant bucket mounted on a front-end loader will be used to transplant large pines from areas to be mined to areas where natural moisture seems highest, such as north-facing slopes of drainageways. The use of native, mature trees may be possible, but it may be more practical to get mature pine from nursery stock. Trees up to 12 m (40 ft) high can be moved in this manner and will provide a seed source for the immediate area. (Specific details on the best current transplanting practices are discussed in Transplanting Native Vegetation, Section 3.3.1.d.)

g. Animal damage control. Vexar seedling protectors may be used to reduce clipping and browsing damage by deer and rabbits if necessary. These plastic, photodegradable tubes should protect the seedlings for three to five years after planting or until they are 100 cm (40 in) tall. If rodent damage

to the roots of the young trees becomes apparent, an EPA-approved rodenticide may be used. (For more details and other methods of control, see Section 3.3.1.j, Pest Control.)

4.6 ADDITIONAL ENHANCEMENT FOR WILDLIFE

4.6.1 Brushpiles and Rock Piles

Brush which had been stockpiled during the clearing operation for the mine will be trucked to regraded areas and placed in piles approximately 1.5 m (5 ft) high and 3.1 m (10 ft) in diameter. No more than three piles/ha (one pile/acre) will be created. The piles will contain a variety of woody material, varying from logs not more than 20 cm (8 in) in diameter to small saplings, sagebrush, and debris cuttings. It is expected that these piles will provide cover for small wildlife, both game and nongame species (Gutierrez et al. 1979). Rock piles will also be formed from rock gathered after the final grading. These piles will be no more than 2 m (6 ft) high and 6 m (20 ft) in diameter. Approximately three piles/ha (one pile/acre) will be created.

4.6.2 Nest Boxes

Ten passerine nest boxes will be erected systematically throughout the area. Nest box dimensions will vary to account for different species identified during the baseline studies. Dimensions for different species are provided in Construction of Nesting Structures for Birds, Section 3.3.3.f. Boxes will be checked periodically through the bonding period to determine if repairs are needed.

One raptor nesting tripod or elevated platform will be placed on the area in a location which will be revegetated with native prairie grasses. Due to the isolation of the reclaimed mine site from populated areas, it is anticipated that a raptor nesting structure could be utilized successfully on the area by either hawks or golden eagles (Grubb 1980).

4.6.3 Access Restriction

Access to the reclamation site will be prohibited to encourage reclamation growth and wildlife protection. Locked gates will be erected at access points off the main roads to the site and signs posted as follows: Porcupine Mine; Private Property; Access by Permission Only; 1910 Coal St., Denver, CO.

4.7 REFERENCES

- Alexander, R. R. Silviculture of central and southern Rocky Mountain forests: a summary of the status of our knowledge by timber types. Research Paper RM 120: USDA Forest Service; Rocky Mountain Forest and Range Experiment Station; U.S. Department of Agriculture: Ft. Collins, CO; 1974.
- Arno, S. F. Forest regions of Montana. Research paper INT-218: USDA Forest Service; Intermountain Forest and Range Experiment Station; U.S. Department of Agriculture: Ogden, UT; 1979.

- Bjugstad, A. J. Reestablishment of woody plants on mine spoils and management of mine water impoundments: an overview of Forest Service research on the northern high plains. Pages 3-12 In Wright, R. A., ed. The reclamation of disturbed arid lands. Albuquerque. Univ. N. Mex. Press; 1978.
- Boldt, C. E.; Uresk, D. W.; Severson, K. E. Riparian woodlands in jeopardy in northern high plains. Paper presented at the National symposium on strategies for protection and management of floodplain wetlands and other riparian ecosystems: Callaway Gardens, Atlanta, GA; 1978.
- Grubb, T. G. An artificial bald eagle nest. Ft. Collins, CO: USDA Forest Service. Rocky Mountain Forest and Range Experiment Station. Research Note RM-338; March 1980.
- Gutiérrez, R. J.; Decker, D. J.; Howard, R. A., Jr.; Lassole, J. P. Managing small woodlands for wildlife. Extension Services Info. Bull. 157. Ithaca, New York: New York State College of Agriculture and Life Sciences at Cornell University; 1979.
- McKnight, J. S. Planting cottonwood cuttings for timber production in the south. USDA Forest Serv. Res. Pap. 50-60: Forest Exp. Sta. New Orleans; 1970. 17 p.
- Orr, H. K. Reestablishment of wooded waterways and associated upland shrub communities in surface coal mining areas of the northwestern Great Plains. In Fifth symposium surface mining and reclamation; NCA/BCR Coal Conference and Expo IV: Louisville, KY; 1977.
- Severson, K. E.; Boldt, C. E. Cattle, wildlife, and riparian habitats in the western Dakotas. In Management and rise of northern plains rangeland. Reg. rangeland symposium: Bismarck, ND; 1978.
- Shell Oil Co. Permit to mine application - North Rochelle Mine. Shell Oil Company: Campbell County, WY; 1981.
- Steenhof, K. The ecology of wintering bald eagles in southeastern South Dakota. M.S. Thesis. Univ. of Missouri, Columbia; 1976. 148 p.
- Westmoreland Resources. Permit to mine application. Absaloka Mine, Big Horn County, Montana, Westmoreland Resource; 1978.
- Wyoming Department of Game and Fish. Considerations for wildlife in industrial development and reclamation; 1976. 65 p.

APPENDIX A
SOURCES OF INFORMATION

This list includes only public agencies and institutions. States covered in this handbook are listed alphabetically. Categories under each State are State and Federal Agencies, universities, and agricultural experiment stations. Listings under these categories are alphabetically arranged.

MONTANA

State Agencies

Surface Mining Regulatory Authority

Division of Reclamation
Department of State Lands
Capitol Station
Helena, MT 59601
(406) 449-2074

Natural Resources

Department of Natural Resources and Conservation
32 South Ewing
Helena, MT 59601
(406) 449-3712

Fish and Wildlife

Department of Fish, Wildlife and Parks
1420 East Sixth
Helena, MT 59601
(406) 449-2535

Forestry

Forestry Division
Department of Natural Resources and Conservation
2705 Spurgin Road
Missoula, MT 59801
(406) 728-4300

Extension Services (Agriculture)

State Extension Services
Montana State University
Bozeman, MT 59717
(406) 994-3402

MONTANA (continued)

Water Resources Technology

Montana University Joint Water Resources Research Center
Montana State University
207 Montana Hall
Bozeman, MT 59717
(406) 994-2891

Federal Agencies

Department of Agriculture

U.S. Forest Service
Northern Regional Office
Federal Building
Missoula, MT 59807
(406) 329-3316

USDA Forest Service
Equipment Development Center
Fort Missoula
Missoula, MT 59801
(406) 329-3157

Soil Conservation Service
Federal Building
P. O. Box 970
Bozeman, MT 59715
(406) 587-5271 ext. 4322

Bridger Plant Materials Center
Route 1, Box 81
Bridger, MT 59014

Department of the Army

U.S. Army Engr. District, Omaha
6014 USPO & Courthouse
Omaha, NE 68102
(402) 221-3900

U.S. Army Engr. District, Seattle (Northwest Montana)
P. O. Box C-3755
Seattle, WA 98124
(206) 764-3690

MONTANA (continued)

Department of the Interior

Office of Surface Mining, Reclamation and Enforcement
Region V
Brooks Towers
1020 15th Street
Denver, CO 80202
(303) 837-4731

Bureau of Land Management
Granite Tower
222 N. 32nd Street, P. O. Box 30157
Billings, MT 59107
(406) 657-6462

Bureau of Mines
Western Field Operations Center
E. 315 Montgomery Avenue
Spokane, WA 99207
(509) 484-1610

U.S. Fish and Wildlife Service
Region 6
P. O. Box 25486
Denver Federal Center
Denver, CO 80225
(303) 234-3990

U.S. Fish and Wildlife Service
Office of Endangered Species
P. O. Box 25486
Denver Federal Center
Denver, CO 80225
(303) 234-2496

U.S. Fish and Wildlife Service
Coal Coordinator
Federal Building
Room 3035
316 N. 26th Street
Billings, MT 59101
(406) 657-6570

U.S. Fish and Wildlife Service
Area Manager
316 North 26th St.
Billings, MT 59101
(406) 657-6262

MONTANA (continued)

Bureau of Reclamation
Upper Missouri Region
P. O. Box 2553
Federal Building
316 N. 26th Street
Billings, MT 59103
(406) 657-6214

Bureau of Reclamation
Pacific Northwest Region (Northwest Montana)
P. O. Box 043
U.S. Courthouse
550 W. Fort Street
Boise, ID 83724
(208) 384-1908

Universities and Agricultural Experiment Stations

Montana Agricultural Experiment Station
Montana State University
Bozeman, MT 59717
(406) 994-4821

Montana State University
Wildlife Department
Bozeman, MT 59717
(406) 994-2450

University of Montana
Wildlife Biology Program
Missoula, MT 59812
(406) 243-5521

NORTH DAKOTA

State Agencies

Surface Mining Regulatory Authority

Reclamation Division
Public Service Commission
600 Boulevard Avenue East
Bismarck, ND 58554
(701) 224-2400

NORTH DAKOTA (continued)

Fish and Wildlife

State Game and Fish Department
2121 Lovett Avenue
Bismarck, ND 58505
(701) 224-2180

Forestry

State Forest Service
North Dakota State University
Bottineau Branch and Institute of Forestry
Bottineau, ND 58318
(701) 228-2278

Soils

State Soil Conservation Committee
State Capitol Building
Bismarck, ND 58505
(701) 224-2650

Extension Services (Forestry)

Cooperative Extension Service
North Dakota State University
Fargo, ND 58102
(701) 237-8944

Water Resources Technology

Water Resources Research Institute
North Dakota State University
Fargo, ND 58102
(701) 237-7765

Federal Agencies

Department of Agriculture

Soil Conservation Service
Federal Building
Rosser Ave. & 3rd St.
Bismarck, ND 58501
(701) 255-4011

Northern Great Plains Research Center
P. O. Box 459
Mandan, ND 58554
(701) 663-6445

NORTH DAKOTA (continued)

Department of the Army

U.S. Army Engr. District, Omaha
(Southwest North Dakota)
6014 USPO & Courthouse
Omaha, NE 68102
(402) 221-3900

U.S. Army Engr. District, St. Paul
(Northeast North Dakota)
1135 USPO & Custom House
St. Paul, MN 55101
(612) 725-7501

Department of the Interior

Office of Surface Mining, Reclamation and Enforcement
Region V
Brooks Towers
1020 15th Street
Denver, CO 80202
(303) 837-4731

Bureau of Land Management
Denver Service Center
Denver Federal Center, Building 50
Denver, CO 80225
(303) 334-2329

Bureau of Mines
Intermountain Field Operations Center
Bldg. 10, Denver Federal Center
Denver, CO 80225
(303) 234-6866

U.S. Fish and Wildlife Service
Region 6
P.O. Box 25486
Denver Federal Center
Denver, CO 80225
(303) 234-3990

U.S. Fish and Wildlife Service
Office of Endangered Species
P. O. Box 25486
Denver Federal Center
Denver, CO 80225
(303) 234-2496

NORTH DAKOTA (continued)

U.S. Fish and Wildlife Service
Coal Coordinator
1500 Capital Avenue
P. O. Box 1897
Bismarck, ND 58501
(701) 783-4492

U.S. Fish and Wildlife Service
Area Manager
1500 Capitol Ave.
Bismarck, ND 58501
(701) 255-4011

Bureau of Reclamation
Upper Missouri Region
P. O. Box 2553
Billings, MT 59103
(406) 657-6214

Universities and Agricultural Experiment Stations

North Dakota Agricultural Experiment Station
North Dakota State University
State University Station
Fargo, ND 58102
(701) 237-7654

North Dakota State University
Zoology Dept.
Fargo, ND 58105
(701) 237-7087

University of North Dakota
Wildlife Dept.
Grand Forks, ND 58202
(701) 777-2621

WYOMING

State Agencies

Surface Mining Regulatory Authority

Land Quality Division
Department of Environmental Quality
Hathaway Building
401 West 19th
Cheyenne, WY 82002
(307) 777-7756

WYOMING (continued)

Fish and Wildlife

Game and Fish Department
Cheyenne, WY 82002
(307) 777-7631

Heritage and Conservation Program

Wyoming Natural Heritage Program
1603 Capitol Avenue, Room 325
Cheyenne, WY 82001
(307) 634-9629

Forestry

State Forestry Division
1100 West 22nd Street
Cheyenne, WY 82002
(307) 777-7586

Extension Services (Forestry, Range Management)

State Extension Services
Box 3354, University Station
Laramie, WY 82071
(307) 766-4133

Water Resources Technology

Water Resources Research Institute
University of Wyoming
P. O. Box 3067
University Station
Laramie, WY 82071
(307) 766-2143

Federal Agencies

Department of Agriculture

U.S. Forest Service
Rocky Mountain Regional Office
11177 West 8th Avenue
Box 25127
Lakewood, CO 80225
(303) 234-4185

WYOMING (continued)

U.S. Forest Service
Rocky Mountain Forest and Range Experiment Station
240 W. Prospect
Ft. Collins, CO 80521
(303) 221-4390

U.S. Forest Service
Rocky Mountain Forest and Range Experiment Station
222 South 22nd Street
Laramie, WY 82070
(307) 742-6621

Soil Conservation Service
Federal Office Bldg.
P. O. Box 2440
Casper, WY 82601
(307) 265-5550

Highlands Grasslands Research Center
8408 Hildreth Rd.
Cheyenne, WY 82001
(307) 778-2220

Department of the Army

U.S. Army Engr. District, Omaha (Eastern Wyoming)
6014 USPO & Courthouse
Omaha, NE 68102
(402) 221-3900

U.S. Army Engr. District, Sacramento
(Southwest Wyoming)
650 Capital Mall
Sacramento, CA 95814
(916) 440-2232

Department of the Interior

Office of Surface Mining, Reclamation and Enforcement
Region V
Brooks Towers
1020 15th Street
Denver, CO 80202
(303) 837-4731

WYOMING (continued)

Bureau of Land Management
Lea Building
2515 Warren Avenue
P. O. Box 1828
Cheyenne, WY 82001
(307) 778-2326

Bureau of Mines
Intermountain Field Operations Center
Bldg. 20, Denver Federal Center
Denver, CO 80225
(303) 234-6866

Bureau of Mines
Denver Mining Research Center
Denver Federal Center
Denver, CO 80225
(303) 234-4060

U.S. Fish and Wildlife Service
Region 6
P. O. Box 25486
Denver Federal Center
Denver, CO 80225
(303) 234-3990

Office of Endangered Species
U.S. Fish and Wildlife Service
P. O. Box 25486
Denver Federal Center
Denver, CO 80225
(303) 234-2496

U.S. Fish and Wildlife Service
Coal Coordinator
J. C. Mahoney Federal Center
2120 Capitol Avenue
Room 7009
Cheyenne, WY 82001
(307) 328-2374

U.S. Fish and Wildlife Service
Sheridan Field Station
50 E. Loucks
Sheridan, WY 82801
(307) 672-5826

WYOMING (continued)

U.S. Fish and Wildlife Service
Western Energy and Land Use Team (WELUT)
Drake Creekside Building
2625 Redwing Road
Ft. Collins, CO 80521
(303) 226-9100

Bureau of Reclamation
Upper Missouri Region (Northern Wyoming)
P. O. Box 2553
Billings, MT 59103
(406) 657-6218

Bureau of Reclamation
Building 20
Denver Federal Center
Denver, CO 80225
(303) 234-4441

Bureau of Reclamation
Upper Colorado Region (Southwest Wyoming)
P. O. Box 11568
Salt Lake City, UT 84111
(801) 524-5592

Universities and Agricultural Experiment Stations

Wyoming Agricultural Experiment Station
University of Wyoming
Box 3354, University Station
Laramie, WY 82071
(307) 766-4133

University of Wyoming
Department of Zoology and Physiology
University Station
Box 3166
Laramie, WY 82071
(307) 766-4207

APPENDIX B
NAMES OF PLANTS MENTIONED IN THE TEXT

COMMON NAME	SCIENTIFIC NAME
Alfalfa	<u>Medicago sativa</u>
Almond, Russian	<u>Prunus tenella</u>
Apache-plume, common	<u>Fallugia paradoxa</u>
Arnica	<u>Arnica</u> spp.
Ash, green	<u>Fraxinus pennsylvanica lanceolata</u>
Aspen (quaking aspen)	<u>Populus tremuloides</u>
Aster, woody	<u>Aster xylorrhiza</u>
Aster	<u>Aster</u> spp.
Barley	<u>Hordeum</u> spp.
Bitterbrush, antelope	<u>Purshia tridentata</u>
Bitterbrush	<u>Purshia</u> spp.
Bluegrass, bulbous	<u>Poa bulbosa</u>
Bluegrass, Kentucky	<u>Poa pratensis</u>
Bluegrass, Sandberg	<u>Poa secunda</u>
Bluegrass	<u>Poa</u> spp.
Bluestem, big	<u>Andropogon gerardi</u>
Bluestem, little	<u>Andropogon scoparius</u>
Boxelder	<u>Acer negundo</u>
Brome, smooth	<u>Bromus inermis</u>
Buffaloberry, silver	<u>Shepherdia argentea</u>
Buffaloberry	<u>Shepherdia</u> spp.
Buffalograss	<u>Buchloe dactyloides</u>
Caragana (peashrub)	<u>Caragana</u> spp.
Cherry, Nanking	<u>Prunus tomentosa</u>
Cherry, sand (Bessey cherry)	<u>Prunus besseyi</u>
Chokecherry (common)	<u>Prunus virginiana</u>
Clover, red	<u>Trifolium pratense</u>
Clover, white	<u>Trifolium repens</u>
Cottonwood (plains)	<u>Populus sargentii</u>
Crabapple, Manchurian	<u>Malus baccata mandshurica</u>
Crabapple, midwest (prairie)	<u>Malus ioensis</u>
Currant, wax	<u>Ribes cereum</u>
Currant	<u>Ribes</u> spp.
Dandelion, common	<u>Taraxacum officinale</u>
Danthonia, onespice	<u>Danthonia unispicata</u>
Dogwood, red osier	<u>Cornus stolonifera</u>
Dropseed, sand	<u>Sporobolus cryptandrus</u>
Duckweed	<u>Lemna</u> spp.
Elm, American	<u>Ulmus americana</u>
Elm, Siberian	<u>Ulmus pumila</u>

COMMON NAME	SCIENTIFIC NAME
Fescue, Idaho	<u>Festuca idahoensis</u>
Fescue, sheep	<u>Festuca ovina</u>
Gayfeather, dotted	<u>Liatris punctata</u>
Gilia, spike	<u>Ipomopsis spicata</u>
Globemallow, scarlet	<u>Sphaeralcea coccinea</u>
Gramma, blue	<u>Bouteloua gracilis</u>
Gramma, sideoats	<u>Bouteloua curtipendula</u>
Grape, Oregon	<u>Mahonia repens</u>
Greasewood	<u>Sarcobatus vermiculatus</u>
Hawthorn, fleshy	<u>Crataegus succulenta</u>
Hawthorn	<u>Crataegus</u> spp.
Hedgerose, Hansen	<u>Rosa</u> spp.
Juneberry (Saskatoon serviceberry)	<u>Amelanchier alnifolia</u>
Junegrass, prairie	<u>Koeleria cristata</u>
Juniper, creeping	<u>Juniperus horizontalis</u>
Juniper, Rocky Mountain	<u>Juniperus scopulorum</u>
Juniper	<u>Juniperus</u> spp.
Kinnikinnik (bearberry manzanita)	<u>Arctostaphylos uva-ursi</u>
Lettuce, prickly	<u>Lactuca serriola</u>
Milkvetch, chickpea	<u>Astragalus cicer</u>
Milkvetch, standing	<u>Astragalus adsurgens robustior</u>
Mockorange, littleleaf	<u>Philadelphus microphyllus</u>
Mountainmahogany, curleaf	<u>Cercocarpus ledifolius</u>
Mountainmahogany, true	<u>Cercocarpus montanus</u>
Mountainmahogany	<u>Cercocarpus</u> spp.
Needle-and-thread	<u>Stipa comata</u>
Needlegrass, green	<u>Stipa viridula</u>
Oak, bur	<u>Quercus macrocarpa</u>
Oak, Gambel	<u>Quercus gambelii</u>
Oak	<u>Quercus</u> spp.
Oat	<u>Avena</u> spp.
Olive, Russian	<u>Elaeagnus angustifolia</u>
Orchardgrass	<u>Dactylis glomerata</u>
Pea	<u>Pisum</u> spp.
Penstemon	<u>Penstemon</u> spp.
Pine, pinyon	<u>Pinus edulis</u>
Pine, ponderosa	<u>Pinus ponderosa</u>
Pine	<u>Pinus</u> spp.
Plum	<u>Prunus</u> spp.
Plum, American	<u>Prunus americana</u>
Prairieconeflower	<u>Ratibida</u> spp.

COMMON NAME	SCIENTIFIC NAME
Rabbitbrush, Douglas	<u>Chrysothamnus viscidiflorus</u>
Rabbitbrush, rubber	<u>Chrysothamnus nauseosus</u>
Ricegrass, Indian	<u>Oryzopsis hymenoides</u>
Rose, redleaf	<u>Rosa rubrifolia</u>
Rose, Wood's (western wild rose)	<u>Rosa woodsii</u>
Rush	<u>Juncus spp.</u>
Russianthistle	<u>Salsola kali</u>
Rye	<u>Secale spp.</u>
Ryegrass, perennial	<u>Lolium perenne</u>
Sacaton, alkali	<u>Sporobolus airoides</u>
Sagebrush, big	<u>Artemisia tridentata</u>
Sagebrush, Wyoming big	<u>Artemisia tridentata wyomingensis</u>
Sagebrush, black	<u>Artemisia nova</u>
Sagebrush, fringed (sagewort)	<u>Artemisia frigida</u>
Sagebrush, silver	<u>Artemisia cana (cana)</u>
Sagebrush	<u>Artemisia spp.</u>
Sagewort, birdfoot	<u>Artemisia pedatifida</u>
Saltbush, fourwing	<u>Atriplex canescens</u>
Saltbush, shadscale	<u>Atriplex confertifolia</u>
Saltbush, spiny	<u>Atriplex spinescens</u>
Saltbush	<u>Atriplex spp.</u>
Sandreed, prairie	<u>Calamovilfa longifolia</u>
Sedge, needleleaf	<u>Carex, eleocharis</u>
Sedge, sun	<u>Carex heliophila</u>
Sedge, threadleaf (dryland sedge)	<u>Carex filifolia</u>
Sedge, woolly	<u>Carex lanuginosa</u>
Sedge	<u>Carex spp.</u>
Serviceberry, Saskatoon	<u>Amelanchier alnifolia</u>
Serviceberry	<u>Amelanchier spp.</u>
Silverberry	<u>Elaeagnus commutata</u>
Skunkbush (sumac)	<u>Rhus trilobata trilobata</u>
Smartweed	<u>Polygonum spp.</u>
Snowberry, common	<u>Symphoricarpos albus</u>
Snowberry, western	<u>Symphoricarpos occidentalis</u>
Snowberry	<u>Symphoricarpos spp.</u>
Sorghum, common	<u>Sorghum vulgare</u>
Spikerush	<u>Eleocharis spp.</u>
Spruce, blue	<u>Picea pungens</u>
Spurge, leafy	<u>Euphorbia esula</u>
Sudan-grass	<u>Sorghum halepense</u>
Sumac, skunkbrush	<u>Rhus trilobata trilobata</u>
Sweetclover, white	<u>Melilotus alba</u>
Sweetclover, yellow	<u>Melilotus officinalis</u>
Sweetclover	<u>Melilotus spp.</u>
Switchgrass	<u>Panicum virgatum</u>

COMMON NAME	SCIENTIFIC NAME
Thermopsis, prairie	<u>Thermopsis rhombifolia</u>
Thistle, Canada	<u>Cirsium arvense</u>
Timothy	<u>Phleum spp.</u>
Vetch, American	<u>Vicia americana</u>
Wheatgrass, beardless bluebunch	<u>Agropyron spicatum spicatum</u>
Wheatgrass, bluebunch	<u>Agropyron spicatum</u>
Wheatgrass, crested	<u>Agropyron cristatum</u>
Wheatgrass, fairway	<u>Agropyron cristatum</u>
Wheatgrass, intermediate	<u>Agropyron intermedium</u>
Wheatgrass, pubescent	<u>Agropyron trichophorum</u>
Wheatgrass, slender	<u>Agropyron trachycaulum</u>
Wheatgrass, streambank	<u>Agropyron riparium</u>
Wheatgrass, tall	<u>Agropyron elongatum</u>
Wheatgrass, western	<u>Agropyron smithii</u>
Whitetop	<u>Cardaria spp.</u>
Wild buckwheat	<u>Eriogonum spp.</u>
Wildrye, basin	<u>Elymus cinereus</u>
Wildrye, Canada	<u>Elymus canadensis</u>
Wildrye, Russian	<u>Elymus junceus</u>
Willow, peachleaf	<u>Salix amygdaloides</u>
Willow	<u>Salix spp.</u>
Willowherb, fireweed	<u>Epilobium angustifolium</u>
Winterfat (common)	<u>Ceratoides lanata</u>
Wintergreen, one-sided	<u>Ramischia secunda</u>
Yarrow, western	<u>Achillea lanulosa</u>

Nomenclature primarily follows Beetle [1970 (Recommended plant names. Univ. of Wyoming Agric. Exp. Stn. Res. J. 31. Laramie. 124 p.)] and Weber [1976 (Rocky Mountain flora. Colorado Assoc. Press, Boulder. 479 p.)].

APPENDIX C
 NAMES OF ANIMALS MENTIONED IN THE TEXT

COMMON NAME	SCIENTIFIC NAME
Antelope (pronghorn)	<u>Antilocapra americana</u>
Badger	<u>Taxidea taxus</u>
Bass, largemouth	<u>Micropterus salmoides</u>
Bluebird, mountain	<u>Sialia currucoides</u>
Bluebird	<u>Sialia spp.</u>
Bluegill	<u>Lepomis macrochirus</u>
Bobcat	<u>Felis rufus</u>
Bullhead, black	<u>Ictalurus melas</u>
Bunting, lark	<u>Calamospiza melanocorys</u>
Canvasback	<u>Aythya valisineria</u>
Catfish, channel	<u>Ictalurus punctatus</u>
Catfish	<u>Ictalurus spp.</u>
Chickadee, black-capped	<u>Parus atricapillus</u>
Chickadee	<u>Parus spp.</u>
Coyote	<u>Canis latrans</u>
Deer, mule	<u>Odocoileus hemionus</u>
Deer, white-tailed	<u>Odocoileus virginianus</u>
Deer	<u>Odocoileus spp.</u>
Dove, mourning	<u>Zenaida macroura</u>
Duck, ruddy	<u>Oxyura jamaicensis</u>
Eagle, bald	<u>Haliaeetus leucocephalus</u>
Eagle, golden	<u>Aquila chrysaetos</u>
Elk	<u>Cervus canadensis</u>
Falcon, peregrine	<u>Falco peregrinus</u>
Ferret, black-footed	<u>Mustela nigripes</u>
Flicker (common)	<u>Colaptes auratus</u>
Flycatcher	<u>Empidonax spp.</u>
Fox, red	<u>Vulpes vulpes</u>
Fox, swift	<u>Vulpes velox</u>
Fox	<u>Vulpes spp.</u>
Gadwall	<u>Anas strepera</u>
Goose, Canada	<u>Branta canadensis</u>
Grosbeak, evening	<u>Hesperiphona vespertina</u>
Groundsquirrels	<u>Citellus spp.</u>
Grouse, Columbian sharp-tailed	<u>Pedioectes phasianellus columbianus</u>
Grouse, sharp-tailed	<u>Pedioecetes phasianellus jamesi</u>
Grouse, sage	<u>Centrocercus urophasianus</u>

COMMON NAME	SCIENTIFIC NAME
Hawk, Cooper's	<u>Accipiter cooperii</u>
Hawk, ferruginous	<u>Buteo regalis</u>
Hawk, marsh	<u>Circus cyaneus</u>
Hawk, red-tailed	<u>Buteo jamaicensis</u>
Hawk, sharp-shinned	<u>Accipiter striatus</u>
Hawk, sparrow	<u>Falco sparverius</u>
Hawk, Swainson's	<u>Buteo swainsoni</u>
Heron	<u>Ardea spp.</u>
Jackrabbit, whitetailed	<u>Lepus townsendii</u>
Jay, Pinyon	<u>Gymnorhinus cyanocephalus</u>
Kestrel	<u>Falco spp.</u>
Kingfisher, belted	<u>Megaceryle alcyon</u>
Lark, horned	<u>Eremophila alpestris</u>
Lark, meadow	<u>Sturnella neglecta</u>
Longspur	<u>Calcarius spp.</u>
Magpie	<u>Pica pica</u>
Mallard	<u>Anas platyrhynchos</u>
Mink	<u>Mustela vison</u>
Minnnows	<u>Cyprinidae</u>
Moose	<u>Alces alces</u>
Mouse, deer	<u>Peromyscus maniculatus</u>
Nuthatch	<u>Sitta spp.</u>
Oriole, Bullock's	<u>Icterus bullockii</u>
Owl, barn	<u>Tyto alba</u>
Owl, burrowing	<u>Speotyto cunicularia</u>
Owl, great horned	<u>Bubo virginianus</u>
Owl, saw-whet	<u>Aegolius acadicus</u>
Owl, screech	<u>Otus asio</u>
Pelican	<u>Pelecanus spp.</u>
Pewee, western wood	<u>Contopus sordidulus</u>
Phoebe	<u>Sayornis spp.</u>
Pigeon (Rock Dove)	<u>Columba livia</u>
Pintail	<u>Anas acuta</u>
Poor-will	<u>Phalaenoptilus nuttallii</u>
Porcupine	<u>Erethizon dorsatum</u>
Prairie dog	<u>Cynomys spp.</u>
Pronghorn (antelope)	<u>Antilocapra americana</u>
Raccoon	<u>Procyon lotor</u>
Rat, pack	<u>Neotoma spp.</u>
Raven	<u>Corvus corax</u>
Redhead	<u>Aythya americana</u>
Robin	<u>Turdus migratorius</u>

COMMON NAME	SCIENTIFIC NAME
Scaup, lesser	<u>Aythya affinis</u>
Shoveler, northern	<u>Anas cylpeata</u>
Skunk, striped	<u>Mephitis mephitis</u>
Snipe, common	<u>Capella gallinago</u>
Sparrow, vesper	<u>Pooecetes gromineus</u>
Sunfish	<u>Lepomis spp.</u>
Swallow, violet-green	<u>Tachycineta thalassina</u>
Swallow	<u>Petrochelidon pyrrhonotea</u>
Swift	<u>Aeronautes saxatalis</u>
Teal, blue-winged	<u>Anas discors</u>
Teal, cinnamon	<u>Anas cyanoptera</u>
Teal, green-winged	<u>Anas crecca carolinensis</u>
Towhee, rufous-sided	<u>Pipilo erythrophthalmus</u>
Trout, brook	<u>Salvelinus fontinalis</u>
Trout, brown	<u>Salmo trutta</u>
Trout, cutthroat	<u>Salmo clarki</u>
Turkey	<u>Meleagris gallopavo</u>
Veery	<u>Catharus fuscescens</u>
Vireo, solitary	<u>Vireo solitarius</u>
Vireo	<u>Vireo spp.</u>
Warbler, yellow	<u>Dendroica petechia</u>
Warbler, yellow-rumped	<u>Dendroica coronata</u>
Waxwing, cedar	<u>Bombycilla cedrorum</u>
Weasel, long-tailed	<u>Mustela frenata</u>
Weasel	<u>Mustela spp.</u>
Wigeon, American	<u>Anas americana</u>
Woodpecker, downy	<u>Dendrocopos pubescens</u>
Woodpecker, hairy	<u>Dendrocopos villosus</u>
Wren, house	<u>Troglodytes aedon</u>
Wren, rock	<u>Salpinctes obsoletus</u>

REPORT DOCUMENTATION PAGE		1. REPORT NO. FWS/OBS-83/10	2.	3. Recipient's Accession No.
4. Title and Subtitle Practices for protecting and enhancing fish and wildlife on coal surface-mined land in the Powder River-Fort Union region.			5. Report Date March 1983	
7. Author(s) Bettina R. Proctor et al.			6.	
9. Performing Organization Name and Address Science Applications, Inc. 2760 29th Street Boulder, CO 80301-1293			8. Performing Organization Rept. No.	
12. Sponsoring Organization Name and Address Western Energy and Land Use Team Division of Biological Services Research and Development Fish and Wildlife Service Washington, DC 20240			10. Project/Task/Work Unit No.	
			11. Contract(C) or Grant(G) No. (C) 14-16-0009-80-075 (G)	
15. Supplementary Notes			13. Type of Report & Period Covered	
16. Abstract (Limit: 200 words) This handbook contains information on the best current practices to minimize disturbances and adverse impacts of surface mining on fish and wildlife resources. Current state and federal legislation was reviewed to determine those practices which were most compatible with the best technology currently available, fish and wildlife plans, and reclamation plans for the Powder River-Fort Union region of the U.S. The information presented includes risks, limitations, approximate costs, and maintenance and management requirements of each practice. Plans for the restoration of specific habitats, according to the best current practices, are also included.			14.	
17. Document Analysis a. Descriptors Surface mining Coal mining Reclamation Wildlife Fishes b. Identifiers/Open-Ended Terms Powder River Habitat improvement Revegetation Montana Wildlife management Wyoming Mitigation North Dakota South Dakota c. COSATI Field/Group				
18. Availability Statement		19. Security Class (This Report)		21. No. of Pages 246
		20. Security Class (This Page)		22. Price

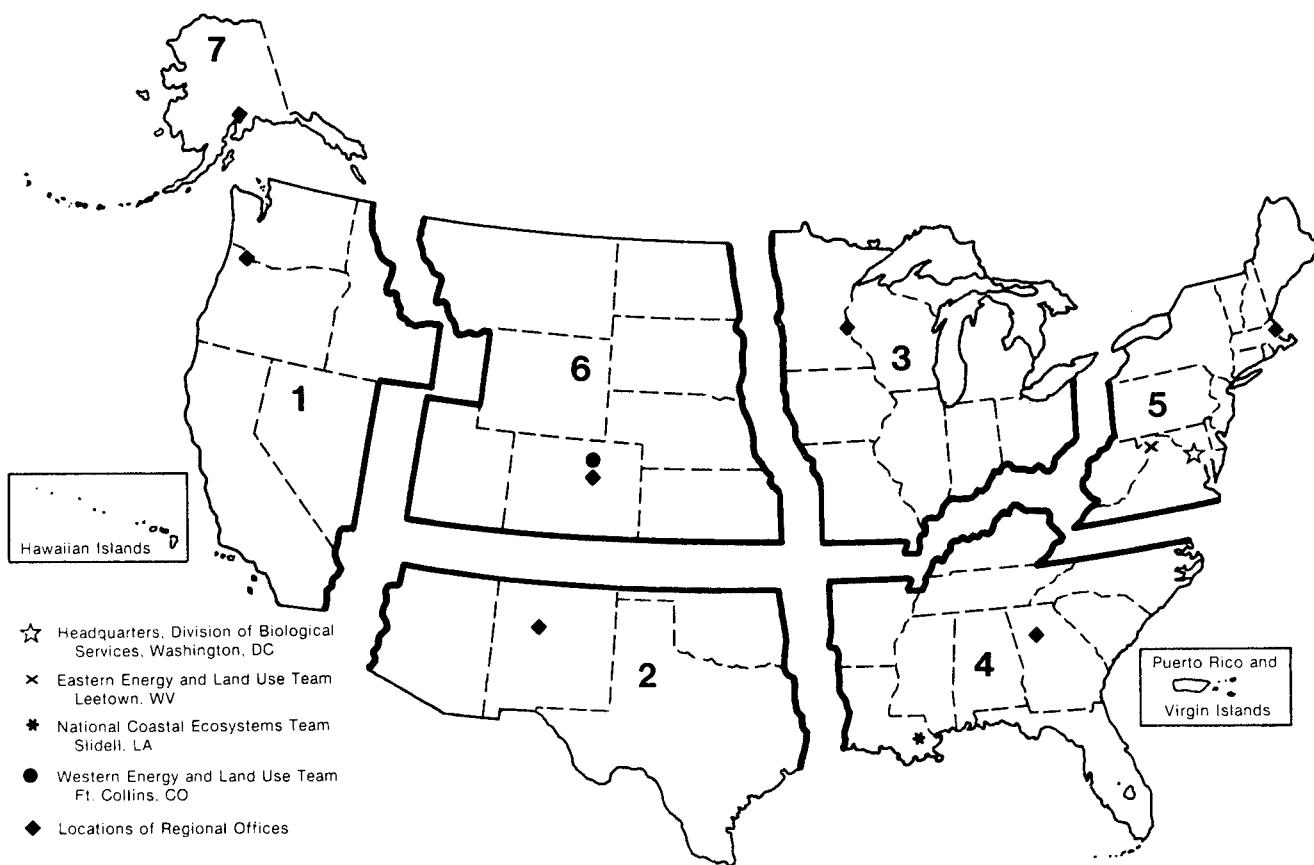

- ☆ Headquarters, Division of Biological Services, Washington, DC
- × Eastern Energy and Land Use Team, Leetown, WV
- * National Coastal Ecosystems Team, Slidell, LA
- Western Energy and Land Use Team, Ft. Collins, CO
- ◆ Locations of Regional Offices

REGION 1

Regional Director
 U.S. Fish and Wildlife Service
 Lloyd Five Hundred Building, Suite 1692
 500 N.E. Multnomah Street
 Portland, Oregon 97232

REGION 2

Regional Director
 U.S. Fish and Wildlife Service
 P.O. Box 1306
 Albuquerque, New Mexico 87103

REGION 3

Regional Director
 U.S. Fish and Wildlife Service
 Federal Building, Fort Snelling
 Twin Cities, Minnesota 55111

REGION 4

Regional Director
 U.S. Fish and Wildlife Service
 Richard B. Russell Building
 75 Spring Street, S.W.
 Atlanta, Georgia 30303

REGION 5

Regional Director
 U.S. Fish and Wildlife Service
 One Gateway Center
 Newton Corner, Massachusetts 02158

REGION 6

Regional Director
 U.S. Fish and Wildlife Service
 P.O. Box 25486
 Denver Federal Center
 Denver, Colorado 80225

REGION 7

Regional Director
 U.S. Fish and Wildlife Service
 1011 E. Tudor Road
 Anchorage, Alaska 99503



DEPARTMENT OF THE INTERIOR
U.S. FISH AND WILDLIFE SERVICE



As the Nation's principal conservation agency, the Department of the Interior has responsibility for most of our nationally owned public lands and natural resources. This includes fostering the wisest use of our land and water resources, protecting our fish and wildlife, preserving the environmental and cultural values of our national parks and historical places, and providing for the enjoyment of life through outdoor recreation. The Department assesses our energy and mineral resources and works to assure that their development is in the best interests of all our people. The Department also has a major responsibility for American Indian reservation communities and for people who live in island territories under U.S. administration.