

FWS/OBS-84/03
APRIL 1984

UTILIZATION OF SURFACE COAL MINE WASTE WATER FOR CONSTRUCTION OF A NORTHERN PIKE SPAWNING/REARING MARSH



19970319 110

Fish and Wildlife Service

U.S. Department of the Interior

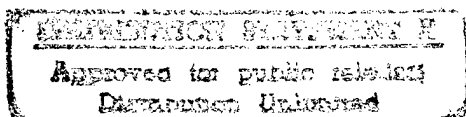

DTIC QUALITY IMPROVED 1

FWS/OBS-84/03
April 1984

UTILIZATION OF SURFACE COAL MINE WASTE WATER
FOR CONSTRUCTION OF A NORTHERN PIKE
SPAWNING/REARING MARSH

by

Richard W. Gregory
Cooperative Fish and Wildlife Research Unit
117 Newins-Ziegler Hall
University of Florida
Gainesville, FL 32611

Allen A. Elser
Department of Fish, Wildlife, and Parks
P.O. Box 430
Miles City, MT 59301

Thomas Lenhart
Cooperative Fishery Research Unit
Department of Biology
Montana State University
Bozeman, MT 59717

FWS 14-16-0008-2117

Performed for
Western Energy and Land Use Team
Division of Biological Services
Research and Development
Fish and Wildlife Service
U.S. Department of the Interior
Washington, DC 20240

DISCLAIMER

Mention of trade names or commercial products does not constitute endorsement or recommendation for use by the Division of Biological Services, Research and Development, Fish and Wildlife Service, U.S. Department of the Interior.

This report should be cited as:

Gregory, R. W., A. A. Elser, and T. Lenhart. 1984. Utilization of surface coal mine waste water for construction of a northern pike spawning/rearing marsh. U.S. Fish Wildl. Serv. FWS/OBS-84/03. 44 pp.

EXECUTIVE SUMMARY

This report presents an example of the use of waste water for fish and wildlife habitat enhancement in the western United States. From 1977-1981, a demonstration project was conducted to rear northern pike in coal mine discharge water for use in stocking the sport fishery of the Tongue River Reservoir, Montana. The project was conducted by the U.S. Fish and Wildlife Service, the Montana Cooperative Fishery Research Unit, Montana Department of Fish, Wildlife and Parks and the Decker Coal Company.

The three components of the study were to: 1) provide habitat suitable for northern pike production; 2) evaluate the use of the new habitat by wildlife; and 3) assess water quality suitability of mine waste water for use in creating new habitats. The Decker Mine typifies surface coal mining in the Northern Great Plains and results from this study should be widely applicable to similar mines, operational or planned, in Wyoming, North and South Dakota, and Montana.

Initially, a preliminary investigation was made of mine waste water suitability for rearing northern pike. Hatching experiments conducted in 1976 and 1977 in pure mine water indicated that the mine water was of sufficient quality to support northern pike. A second component of water quality analysis was a study of heavy metals. Early in the study, a high level of mercury was found in pond water. Tissue analysis on mine water raised pike showed a faster uptake of mercury than for pike in the adjacent reservoir but tissue levels did not approach the 0.5 µg/g EPA guideline. A more detailed study of mercury levels in this area was subsequently conducted and is reported in Phillips et al. (1980).

The pike marsh was constructed beginning in September 1977. Details of design and cost are presented within this report. Several construction and operational problems were encountered in this pioneer project, also outlined in the text, which resulted in water leakage from the marsh and an inability to completely drain the marsh. These two factors made the original plan for pike spawning in pure mine water impossible to carry out. An attempt at pike spawning was made but proved to be mechanically difficult and cost ineffective. Instead, modified plans to use the marsh for pike rearing proved to be very successful.

Pike fry stocked in the newly created marsh produced 4.51 and 19.92 kg/ha in 1978 and 1979, respectively. The 1979 figure exceeded production reported for most pike marshes elsewhere in the United States. Results of analyses of survival, growth, food habits and production are presented in the text.

When the fry reached fingerling size, the fingerlings were released from the marsh into the Tongue River Reservoir to supplement the sport fishery. All fingerlings released into the reservoir were marked with a pelvic fin clip. Gill net catch rates in 1980 reflected the addition of northern pike to the reservoir population. Over 88 percent of the northern pike taken in 1980 were less than 560 mm in length (16 of 18) with an average length of 489 mm. Approximately 80 percent of the pike showed evidence of a right pelvic clip, although fin regeneration masked total recognition.

An index of furbearer and waterfowl was also developed to determine if the marsh provided benefits in addition to the production of northern pike. As little manpower, dollars, or time were available for a thorough furbearer study, a survey of use was conducted only once a year. No specific conclusions could be drawn.

Seven nesting islands were constructed to enhance waterfowl use. Decker Coal Company also planted a cottonwood barrier between the pike marsh and an adjacent highway to reduce harrassment and poaching of waterfowl. Several hundred Canada geese were observed using the marsh in 1981 and evidence of successful hatching of goose eggs was observed on three of the seven islands, with an infertile egg on a fourth.

While several problems were encountered during the course of this study, results indicate that beneficial use to fish and wildlife can be obtained through creation of marsh habitat using coal mine waste water. The difficulties encountered in this project have been outlined in this report to serve as a reference tool for future projects. Not only was the mine water demonstrated as suitable for reuse, a potential for beneficial contribution of northern pike to the sport fishery in the Tongue River Reservoir was demonstrated. Secondary enhancement of the marsh for waterfowl also proved to be successful.

CONTENTS

	<u>Page</u>
EXECUTIVE SUMMARY	iii
FIGURES	vii
TABLES	viii
ACKNOWLEDGMENTS	ix
INTRODUCTION	1
PURPOSE OF STUDY	2
STUDY PLAN	3
Pike Studies	3
Waterfowl and Wildlife Studies	3
Water Quality	4
DESCRIPTION OF THE STUDY AREA	5
MARSH CONSTRUCTION	7
Permits Required	7
Marsh Design	9
Costs	9
MARSH OPERATION FOR PIKE PRODUCTION	10
Marsh Construction and Operation Problems	10
IMPLEMENTATION OF FISHERY PLAN	12
Preliminary Pike Hatching and Rearing Experiments	12
Heavy Metals in Marsh Reared Pike	12
Marsh Stocking	13
Reproductive and Rearing Results Following	
Northern Pike Stocking	15
Survival	15
Growth	15
Food Habits	17
Production	17
Contribution to Reservoir Sport Fishery	19
IMPLEMENTATION OF WILDLIFE PLAN	21
Furbearer Surveys	21
Waterfowl Use	21
MARSH WATER QUALITY	23
DISCUSSION	27
SUMMARY OF PIKE MARSH PROJECT	28
RECOMMENDATIONS	29

CONTENTS (concluded).

	<u>Page</u>
REFERENCES	30
APPENDIXES	
A. History of the Tongue River Reservoir Fishery	33
B. Study Methods	36
C. Review of Pike Production in Marshes	38
D. Marsh Dike (D-1) and Irrigation Head Gate Valve (D-2) Diagrams	42

FIGURES

<u>Number</u>		<u>Page</u>
1	Location map for the Tongue River Reservoir	6
2	Map illustrating the proximity of the pike marsh to the mine and Tongue River	8
3	The relationship between the time northern pike were held in Decker mine sedimentation pond water and resultant mercury concentration in muscle tissue (from Phillips and Gregory 1980)	14
4	Observed growth of northern pike from the Decker pike marsh in 1978, 1979 and 1981, based upon samples taken from seines and the outlet trap	16
D-1	Typical cross section of proposed dike (not drawn to scale)	43
D-2	Pike spawning marsh concrete gate outlet works with top and side views (not drawn to scale)	44

TABLES

<u>Number</u>		<u>Page</u>
1	Growth rates of northern pike from the Decker Marsh, Montana 1979-1981	17
2	Pike fingerling stomach contents sampled in 1979 showing mean number and 95 percent confidence limits (in parentheses) by major food groups	18
3	Comparative production of northern pike in the Decker Marsh, Montana, 1979-1981	19
4	Northern pike production from four marshes in three states	20
5	Comparative density of beaver, muskrat and mink sign per river kilometer on the study area near the Decker pike marsh	22
6	Changes in water quality as a result of mine waste water being stored in the pike marsh	24
7	Selected water quality parameters of Decker Marsh measured in 1978. Changes in water quality due to flood water dilution in mid-May are illustrated	26
A-1	Summary of warmwater fish stocking in the Tongue River Reservoir, 1963-1980	34
A-2	Population estimates of northern pike from trap net catches, Tongue River Reservoir, 1974-1976 (from Elser et al. 1977)	35

ACKNOWLEDGMENTS

We wish to thank the many individuals who contributed to the success of this project. Lee Ischinger (U.S. Fish and Wildlife Service), our original project officer, was instrumental in obtaining funds and assisting in the initial planning of the project. Carl Armour, Phillip Dittberner, and Patricia Ruta Stuber (U.S. Fish and Wildlife Service) also served as subsequent project officers. Sam J. Scott (Decker Coal Company) was a constant source of support and made many substantial contributions beyond those in our cooperative agreement. Anne Hoag and Roger Burton (Decker Coal Company) provided many hours of field assistance. We especially wish to thank Dwight Layton (Decker Coal Company), who was our liaison with his company. Because of his interest in this project and his friendship, many troublesome construction and operational problems were expediently attended to. In later stages of the project, Craig Sorenson (Decker Coal Company) also contributed extra services and assistance. Finally, Steve Whalen and Steve Leathe (Montana Cooperative Fish Research Unit) offered limnological advice and conducted many water and invertebrate sample analyses, in addition to their own projects. Lynn Irby (Montana State University) conducted four of the five furbearer surveys and assisted on other aspects of this project. William Gould (Montana Cooperative Fishery Research Unit) critically reviewed the manuscript. Projects of this nature cannot be conducted without the help cited above and although these people will receive little formal credit, they know their services were invaluable.

INTRODUCTION

As the limited water resources of the western United States are being developed for agricultural and industrial uses, there is an ever increasing need to utilize wastewater to its fullest potential. This report describes one example where wastewater from an energy development site (coal mine operation) was used to enhance the fisheries of an adjacent reservoir. The details of this report provide an example of what considerations may be necessary for similar projects; illustrate potential problem areas in the planning, construction, and operation of such a project; and stimulate ideas for developing other innovative uses of wastewater for fish and wildlife habitat enhancement.

PURPOSE OF STUDY

The vast deposits of subbituminous coal in the Northern Great Plains region of the United States are receiving considerable attention due to current energy problems. Localized disturbances associated with the removal of coal in these areas may offer opportunities for small-scale fish and wildlife enhancement projects. Depending on location, water availability and the need for such projects, enhancement can include marshes for waterfowl nesting, fishing and/or fish rearing impoundments, and revegetation favoring selected wildlife species. A demonstration project to rear fish in mine discharge water for use in stocking the sport fishery of the Tongue River Reservoir was conducted from 1977-1981 in southeastern Montana with Decker Coal Company; the U.S. Fish and Wildlife Service; Montana Department of Fish, Wildlife and Parks; and the Montana Cooperative Fishery Research Unit cooperating. The Decker Mine typifies surface coal mining in the Northern Great Plains and results from this study should be widely applicable to similar mines, operational or planned, in Wyoming, North and South Dakota and Montana.

There were two primary objectives for conducting this study. The first was to enhance the sport fishery for northern pike (Esox lucius) in the Tongue River Reservoir. Northern pike, because of their rapid growth and large size, are highly prized by sport fishermen using the reservoir. Because northern pike use freshwater marshes as spawning and fingerling rearing areas, the importance of these marshes to the species is obvious. In areas such as the Tongue River Reservoir, however, there may be no marshes available. Those that do exist are being lost at an alarming rate, due primarily to human encroachment (Brynildson 1958). And, because frequent fluctuations in water levels and lack of suitable spawning substrate preclude the natural reproduction of pike in many reservoirs, annual stocking is necessary to maintain harvestable population numbers of this popular sport species. Therefore, the establishment of artificial and/or managed rearing marshes may be necessary to ensure adequate pike production or to supplement annual stocking. A review of the history of the Reservoir's fishery is presented in Appendix A.

The second objective of the study was to demonstrate that waste water from a surface coal mine was of sufficient quality and quantity to allow survival and growth of northern pike. Ancillary components of the study included the construction of waterfowl nesting islands in the marsh for use by resident ducks and Canada geese and an evaluation of furbearer use of the newly developed marsh habitat.

STUDY PLAN

The project was divided into three components. The first and major goal was to provide a habitat suitable for northern pike production. A second, ancillary project was to evaluate the use of the new habitat by wildlife. Third, water quality studies were made to obtain information regarding the suitability of mine waste water for use in creating new habitat.

A study plan outlining the three components of the project is described below. More detailed study methods are provided in Appendix B.

PIKE STUDIES

The original study plan called for a preliminary investigation of mine waste water suitability for rearing northern pike. A general review of pike production in marshes is presented in detail in Appendix C. After this preliminary study, the marsh was to be constructed and filled with mine water in early spring. This would allow sufficient time for development of submergent aquatic vegetation for use as pike spawning substrate. Adult northern pike from the Tongue River Reservoir, nearing spawning condition, were to be planted in the marsh, allowed to spawn and then removed from the marsh so they could not affect the survival of the young northern pike.

The second approach was to use the marsh for rearing northern pike fry, obtained elsewhere, until they reached fingerling size. The juveniles were to be marked by fin clipping and released into the Tongue River Reservoir via the marsh outlet. The marsh's contributions to the fishery in the reservoir could then be monitored. A constant overflow from the marsh was to be maintained so the pike fingerlings could emigrate from the marsh into the river and reservoir at a time of their own choosing.

Minor modifications of the above plan were necessary. Because submergent aquatic vegetation could not be expected the first year, winter wheat and western wheat were planted in the fall of 1977 to serve as spawning substrate the following spring. However, unavoidable delays in planting did not allow time for significant seed germination and adult stocking was not attempted in 1978. Instead, the second approach of planting fry was attempted and was so successful, it was repeated in 1979. In 1980, adults were stocked in the marsh to evaluate the potential for producing fish in the marsh by natural spawning.

WATERFOWL AND WILDLIFE STUDIES

Some ancillary studies of waterfowl and furbearer utilization of the newly constructed marsh and nearby areas were to be conducted concurrently with the pike studies.

An index of furbearer use was to be estimated by surveying the river area and recording appropriate sign, i.e., tracks, dens, and scats. The area was to include approximately one mile of river above and below the marsh site with the same route covered each year of the study. It was thought possible that the marsh might influence the numbers of furbearers in the immediate area.

From 5-10 waterfowl nesting islands were also to be constructed in the marsh in an effort to attract Canada geese and resident duck species. The use of these islands was to be monitored by observation and by direct counts of egg shells after nests were deserted each spring. Also, five nesting platforms were to be installed in the marsh and their use by Canada geese evaluated. The platforms were installed in 1978 but construction of the nesting islands was delayed until 1980.

WATER QUALITY

The water quality of mine inflow and the marsh proper was to be monitored twice monthly throughout the filling and pike rearing periods each year. Standard methods were to be employed for analysis of selected water quality parameters. Periodic grab samples were also to be collected for heavy metal analysis. These measurements were to be correlated with pike production each year and to determine what, if any, changes in the quality of mine effluent water might occur as a result of storage in the marsh.

DESCRIPTION OF THE STUDY AREA

The area selected for this project is located in southeastern Montana in the Tongue River watershed, immediately adjacent to the upper end of the Tongue River Reservoir (Fig. 1). The drainage area above the reservoir is 4584 km² (1770 mi²) in size. The river continues 270 km (168 mi) below the reservoir to its confluence with the Yellowstone River near Miles City, Montana. The reservoir is located in Big Horn County, Montana, approximately 34 km (20 mi) north of Sheridan, Wyoming. The reservoir was formed by an earthfill dam completed in May 1939 and is used for flood control, irrigation and recreational activities. The maximum depth of the reservoir is 18 m (59 ft) with an average depth of 5.9 m (19.5 ft) and a surface area of 1277 ha (3156 acres) at maximum pool elevation. A more detailed description of the area can be found in Whalen (1979). A history of the Tongue River fishery is found in Appendix A.

Before mining began in the project area, groundwater flowed along a hydraulic gradient and discharged into the Tongue River (Turbak et al. 1979). Surface mining generally proceeded in a U-shaped manner outward from an initial box cut, thus allowing movement of surface runoff water into the mine cut from various directions. Groundwater also entered the cut via leakage from the exposed aquifers. Surface and groundwater was pumped into a sedimentation pond which periodically overflowed from a stand pipe into the Tongue River floodplain at the upper end of the reservoir near the marsh site.

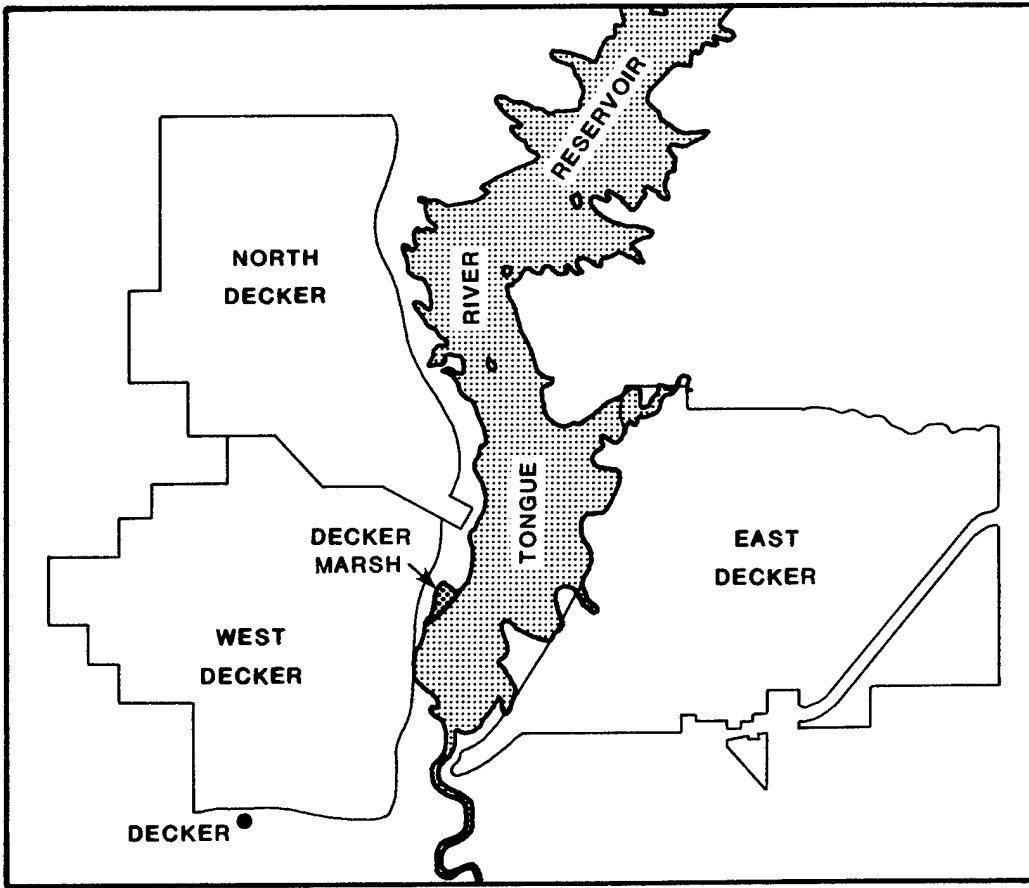
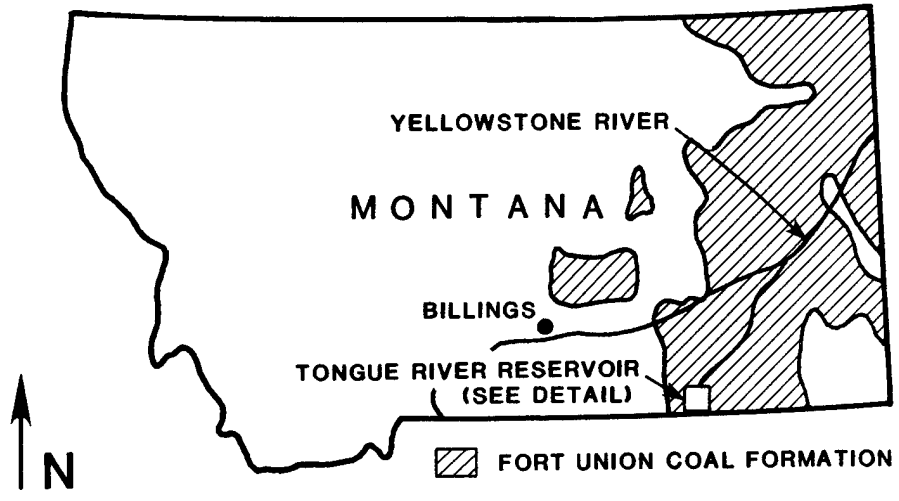

DETAIL

Figure 1. Location map for the Tongue River Reservoir.

MARSH CONSTRUCTION

This section describes the construction of the Decker Marsh and is designed as a general guide for developing a fish and/or wildlife enhancement project associated with a surface coal mine or other extraction processes. Projects similar to the one described here are appropriate only where physiographic and hydrologic conditions are suitable and where there is a need for such an enhancement project.

The specific site selected for the marsh was an old oxbow of the Tongue River, located approximately 400 m (1320 ft) downstream from the discharge point of the mine sedimentation pond (Fig. 2). The site was chosen because of its proximity to an existing mining operation with a discharge thought to be of sufficient quantity to fill and maintain water levels in the marsh. Additionally, a northern extension of the existing mine was proposed for the near future and was predicted to have an even greater quantity of discharge water available when mining operations began (Van Voast and Hedges 1975). Finally, the Tongue River provided a nearby source of supplemental water, if required, as well as direct access to the river for pike released from the marsh.

PERMITS REQUIRED

Special permits may be required before marsh construction can occur. The Decker Marsh was constructed on property owned by the State of Montana and Decker Coal Company and the following permits were required.

<u>Permit</u>	<u>Issuing Agency</u>
Open-cut mining permit	Montana Dept. of State Lands
Easement for marsh site	Montana Dept. of Natural Resources and Conservation
Water use permit	Montana Dept. of Natural Resources and Conservation
Right-of-way for water supply line (state property)	Montana Dept. of Natural Resources and Conservation
Right-of-way for water supply line (county property)	Bighorn County, Montana
Preliminary environmental review	Montana Dept. of Natural Resources and Conservation

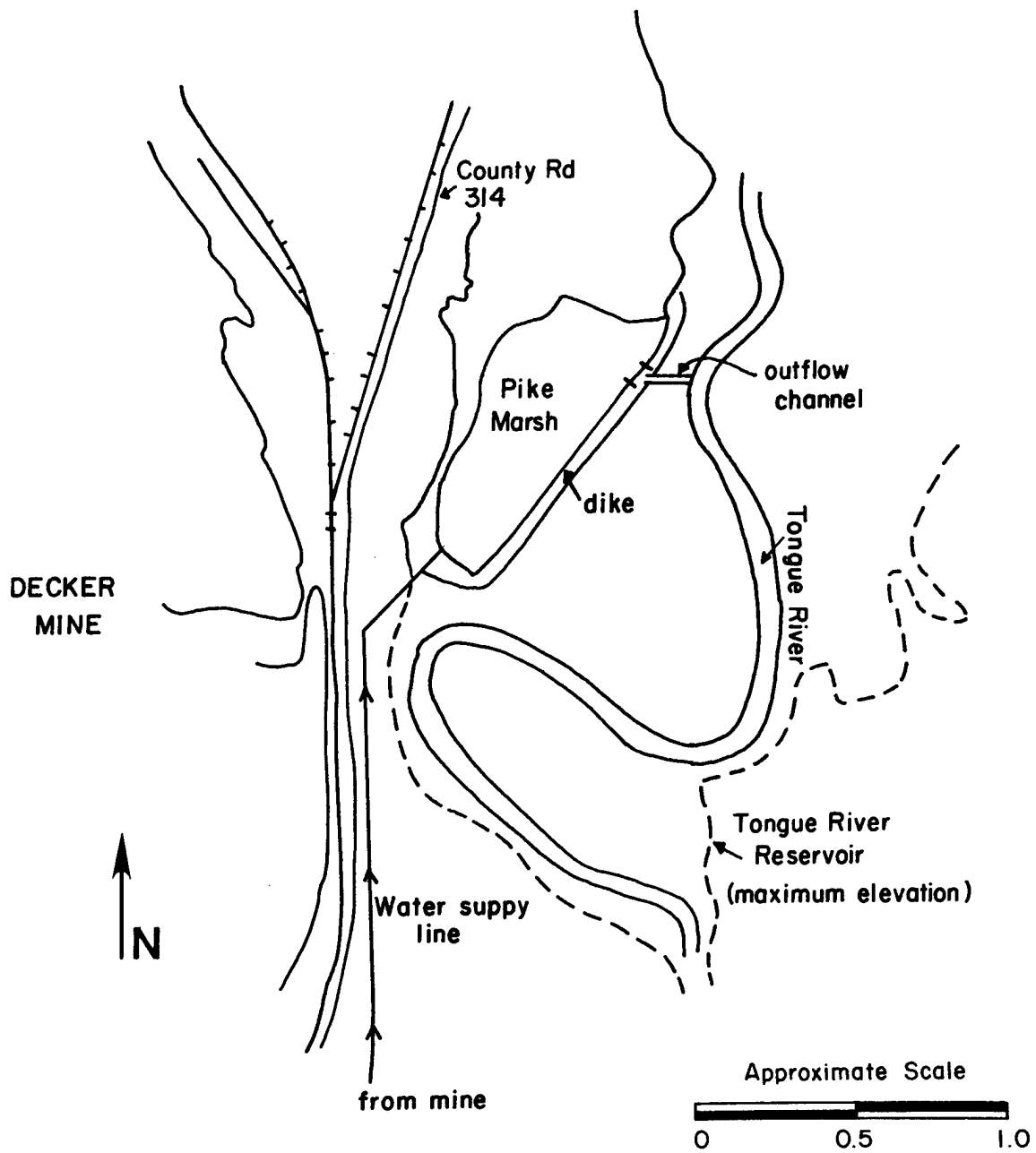

Figure 2. Map illustrating the proximity of the pike marsh to the mine and Tongue River.

For our study, the Montana Department of Fish, Wildlife and Parks was designated as Operator (the party responsible for construction) and the permit process was expedited somewhat. However, the entire process required approximately 6 months and, if water rights had come into question, even more time would have elapsed. We suggest that permit applications be initiated as early as possible for any projects of this nature.

MARSH DESIGN

On September 1977, an earth-fill type dike was constructed for the marsh, making use of material near the site (Fig. D-1). Earth and clay was spread along the dike and compacted with earth moving equipment, using standard techniques. The final slope was 4:1 and 2:1 on the reservoir and marsh sides, respectively. The dike was seeded with intermediate wheatgrass (Agropyron intermedium) and sandfoin (Onobrychis viciaefolia) and then hydromulched.

During the winter of 1977-78, an overflow type outflow structure was constructed with slots for stop logs to maintain the desired water elevation. Water flow from the marsh was controlled with an irrigation head gate valve (24-inch diameter) (Fig. D-2). An inclined plane (Wolf-type) fish trap was installed on the stop logs to evaluate fish emigration from the marsh.

Water for filling the marsh was supplied from the existing sedimentation pond on Decker Coal Company property. Approximately 366 m (1,210 ft) of iron pipe, 15.3 cm (6 inches) in diameter, were installed for pumping water to the marsh from the sedimentation pond. Water was pumped with a 600 gpm turbine pump.

When completely filled, the surface area of the marsh could cover approximately 15 ha (37 acres). However, only about 9 ha (23 acres) were flooded during this study. At this water level, maximum depth near the outflow structure was about 2 m (6.5 ft) with an average depth of 0.75 m (2.5 ft). Water availability limited the size and depth of the flooded area; however, the size of the marsh was large enough for pike production.

COSTS

The construction costs were shared on a 50:50 basis by Decker Coal Company and the U.S. Fish and Wildlife Service. Total construction costs were approximately \$60,000, not including the cost of a secondary outlet (drain) pipe installed in 1979.

MARSH OPERATION FOR PIKE PRODUCTION

The Decker Marsh site offered a unique opportunity because pike could be reared in an environment which, except for any other fishes that might be stocked as forage, would be free of the competition encountered in a natural fishery. Furthermore, all cooperators on this project were interested in whether or not mine discharge water could serve a useful purpose.

MARSH CONSTRUCTION AND OPERATION PROBLEMS

Some of the major problems encountered during this project will be discussed briefly because other persons contemplating similar projects should be aware of the potential unforeseen difficulties.

Three major problems were encountered in the construction of the marsh:

1. The outlet structure was constructed approximately 45 cm above the elevation of the marsh bottom due to an error in surveying. This flaw was not discovered until the marsh was filled the first year and, thus, could not be corrected immediately. This was the most serious problem and made it impossible to completely drain the marsh for removal of northern pike. A second drain pipe through the dike was installed in 1979 to facilitate draining.
2. The failure to remove deadfalls and brush on and near the site of the dike resulted in a leaking dike. This made it nearly impossible to maintain the desired water elevation with the limited quantities of mine waste water. Subsequent additions of bentonite along the dike failed to stop the leakage and it was not possible to maintain water levels in the marsh with mine water.
3. Water from the reservoir entered the marsh during periods of extremely high water. A one way gate should have been installed in the outflow culvert to prevent river water and other fishes from entering the marsh during flooding.

In May 1978, the river and reservoir exceeded the 100-year flood stage and water flowed back through the outflow culvert and into the marsh. As a result, the mine waste water was diluted and large numbers of carp, crappie, suckers, and other fish species entered the marsh. The effect of these fish species on the 1978 production year could not be measured. A screen has since been installed on the reservoir side of the outflow culvert to prevent entry of river fish during future flooding periods.

There were also several problems with operating the marsh:

1. It was difficult to maintain desired water levels and a constant overflow from the marsh with mine water alone. The leakage problem has already been discussed but one of the primary purposes of the project was to demonstrate that mine water alone could be used to produce fish. Each year of the project, it was necessary to augment the mine water supply with water from the Tongue River. Thus, except for a short period prior to the 1978 flood, fish were never held in "pure" mine water.

The constant overflow was specified to encourage fingerling pike to emigrate from the marsh at a time of their own choosing. Because of the erratic availability and supply of water from the mine, it was necessary to drain the marsh to evaluate pike production and manually release fish into the reservoir. Whether or not the pike would have left the marsh on their own could not be determined and, thus, the overflow fish trap was of little use.

2. The marsh could not be completely drained through the outlet structure. As mentioned, this was due to a surveying error. Since fish will not normally exit from a pond being drained until most of the water is gone, the partially-drained pike marsh created a difficult problem relative to fish removal. The remaining pool was rather large and had a soft, muddy bottom, making attempts at electrofishing and seining ineffective. The problem was further compounded in 1978 by the large numbers of carp (2,000-3,000) which entered the marsh during the spring flood. Although seining was much easier in 1979 due to a more stable bottom and lack of other fish species, future projects should be designed so ponds can be completely drained.

IMPLEMENTATION OF FISHERY PLAN

PRELIMINARY PIKE HATCHING AND REARING EXPERIMENTS

The project was designed to use mine waste water for filling and maintaining the marsh. Therefore, it was necessary to conduct some preliminary in situ fertilization and hatching experiments with northern pike in mine water. Prior to hatching experiments, the water quality in the sedimentation pond, including inflow and outflow, had been monitored for a period of 16 months (Turbak et al. 1979; Whalen 1979). These studies indicated that the mine water was of sufficient quality to support northern pike.

Hatching experiments were conducted in April and May, 1976. Five to seven trap nets were run daily to capture sexually mature pike in the reservoir. Spawning pans and mine effluent water were used to fertilize and water harden eggs immediately after each net was run. After water hardening, eggs were transported to a small mobile hatchery, installed adjacent to the sedimentation pond. Water was pumped from the settling pond, through the hatching jars and returned to the pond.

Approximately 20,900 eggs (330 ml at 63.4 eggs/ml) were incubated in hatching jars. The hatching success in the 1976 experiment was roughly 50-60 percent, approximating success obtained in standard pike hatchery operations.

The experiment was repeated in the spring of 1977. Approximately 519,880 eggs were placed in hatching jars, with water again supplied to the mobile hatchery from the sedimentation pond. Water temperature during incubation ranged from 12-21° C, with the upper range much too warm for hatching pike. In addition, a power failure at the mine interrupted water flow through the jars for 12 hours. Although both factors resulted in significant mortality, 2048 pike fry were eventually hatched. As a further check on the suitability of the mine water, all fry were planted into the sedimentation pond for rearing throughout the summer and fall. About 100 sexually mature golden shiners (Notemigonus crysoleucas) were added as a source of forage fish for the northerns.

HEAVY METALS IN MARSH REARED PIKE

A second reason for planting fish in the sedimentation pond was to study mercury uptake. Early in the study, during a screening of mine water for heavy metals, a high level of mercury (10-fold increase above U.S. Environmental Protection Agency (EPA) guideline level) had been found in the pond water (Phillips and Gregory 1980). Therefore, the rate and amount of mercury accumulation was an important part of the determination of mine waste water

suitability for the spawning marsh. As described in more detail by Phillips and Gregory (1980), fingerling pike were collected from the pond (10 in June 1977; 4 in July 1977) and frozen. In early October, the pond was treated with 0.5 ppm rotenone and seven additional pike were recovered and frozen. Tissue analysis showed a mean total mercury content in October pike samples of 0.13 $\mu\text{g/g}$ (Fig. 3). This amount does not approach the 0.5 $\mu\text{g/g}$ EPA guideline, but it did indicate a somewhat faster rate of mercury uptake than for pike in the reservoir (Phillips and Gregory 1980). Results from these analyses have led to a broader evaluation of the relationship between surface mining and elevated mercury concentrations in Northern Great Plains reservoirs (Phillips et al. 1980).

As a check against the possibility of other heavy metals in mine effluent, Phillips (1978) measured concentrations of selenium, arsenic, lead, zinc, and copper in pike raised in both the Decker sedimentation pond and spawning marsh. Except for copper, all other metals were within ranges reported elsewhere. Copper occurred at low concentrations in sedimentation pond fish but was measured at 19.4 $\mu\text{g/g}$ in pike marsh fish after 34 days in the marsh (Phillips 1978). Phillips speculated that, had the mid-May flood of 1978 not occurred, copper might have reached chronically toxic levels.

MARSH STOCKING

Physical problems in the marsh associated with lack of vegetation and inadequate water supply resulted in the decision to stock northern pike fry in 1978 and 1979 rather than evaluating the marsh as a spawning ground. In 1978, 150,000 sac fry northerns were obtained from the Miles City National Fish Hatchery, Montana. No estimates on percent survival were made on these fish prior to stocking the marsh, but fry survival appeared good.

A total of 700,000 fry were transported to the marsh in 1979. However, shipping and handling resulted in an estimated loss of 75 percent of the fry. Based on this estimate, 175,000 northern pike fry were introduced into the marsh.

Adults were placed in the marsh in 1980 to test the spawning potential. Vegetation, primarily Eleocharis (spike rush), had become established in the southeast corner of the marsh, representing about 10 percent of the marsh. An enclosure made of nylon webbing was strung around the vegetated area in order to isolate the area, concentrate the adults, increase the chances for successful reproduction and assist in the adult removal operation. A total of nine adults (six males and three females) were taken from the reservoir with trap nets and transported to the marsh. Total weight of stocked females was 23.61 kg, or 2.6 kg of females/ha of marsh, substantially lower than the recommended 11-14 kg/ha (Fago 1977). Approximately 45 man-days of efforts (\$285/fish) was expended to obtain the spawning stock for the marsh.

Following the introductions, efforts were made to detect spawning activity. There were no visual indications that spawning had taken place. Trap nets were used in the marsh in an attempt to remove the adults. After approximately five weeks of trapping, only four adults were recaptured and returned to the reservoir.

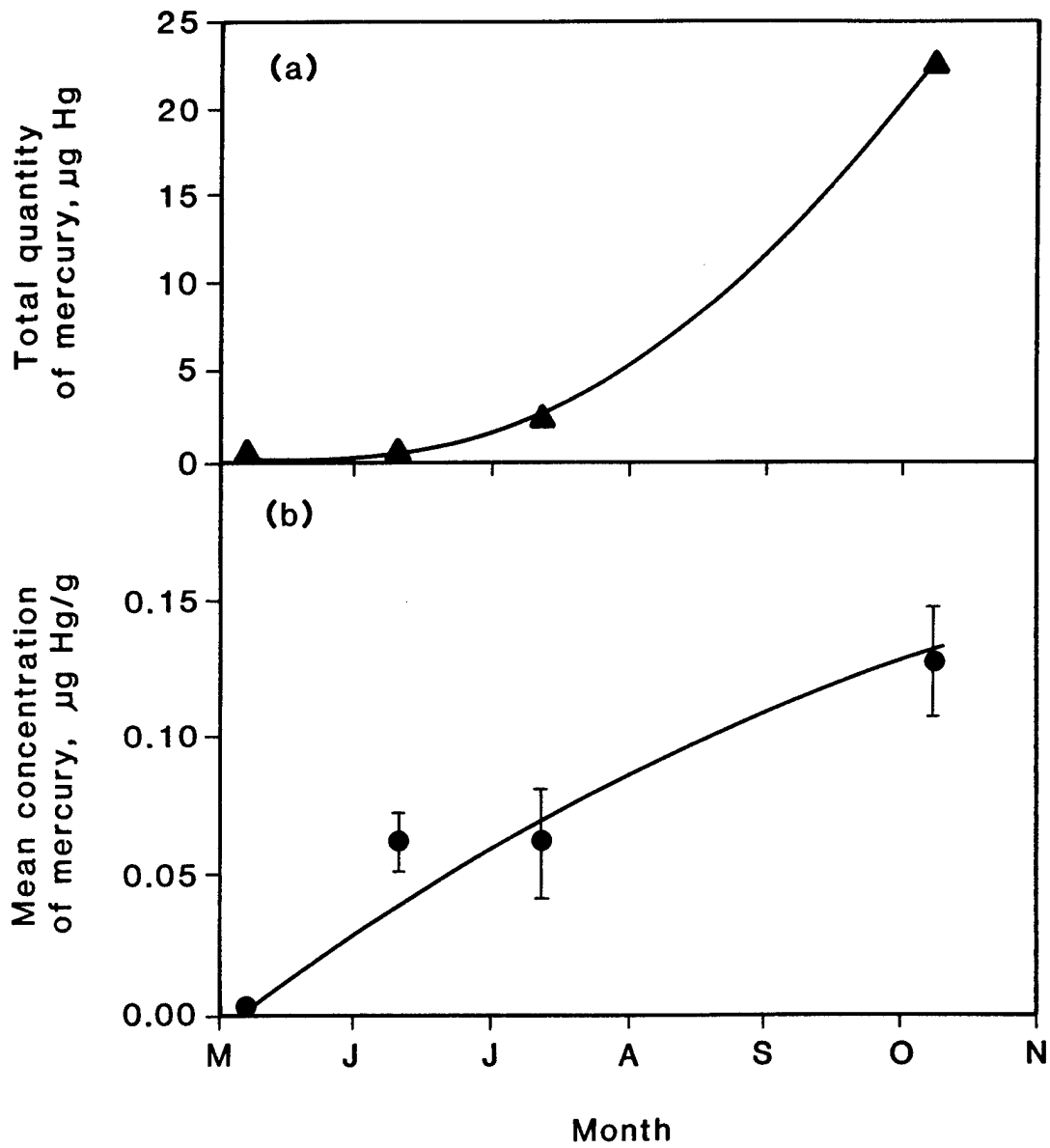

Figure 3. The relationship between the time northern pike were held in Decker mine sedimentation pond water and resultant mercury concentration in muscle tissue (from Phillips and Gregory 1980).

Forage fish were introduced each year. In 1978, 60 golden shiners, taken coincidentally during northern pike trapping, were stocked in the marsh as food for pike fry. Additional forage resulted from approximately 1000 adult carp when the flooding Tongue River flowed into the marsh through the outflow structure. The carp subsequently spawned and produced a large amount of forage. Twenty-eight adult golden shiners and 10 adult carp were released into the marsh in 1979 as spawning stock for the production of young-of-the-year forage fish. Adult crappies taken while trapping northern pike were added as spawning stock for a forage base in 1980.

REPRODUCTIVE AND REARING RESULTS FOLLOWING NORTHERN PIKE STOCKING

Survival

In 1978, 254 fingerling northern pike were recovered from the marsh for a survival rate of 0.17 percent (254 of 150,000). This is a minimum figure because all fish could not be removed from the marsh and an unknown number died in the shallow, muddy water during removal procedures. By comparison, 5,165 fingerling northern pike were recovered in 1979 for a survival rate of 2.95 percent (5,165 of 175,000). These results are similar to fingerling survival rates reported by Fago (1977) of 0.15-2.69 percent.

Only 18 fingerlings were recovered in 1980 as a result of natural reproduction in the marsh. Assuming maximum spawning occurred, the survival was 0.004 percent, based on estimated fecundity and direct counts of young produced.

Growth

Growth of pike fingerlings in 1978, 1979, and 1981 are compared in Figure 4. Pike grew at a slower rate in 1979 than in 1978 but growth in 1981 exceeded both years. Slower growth in 1979 was probably due to the greater density of pike. Growth rates for 1980 were not considered because only 8 fish were produced. Figure 4 shows that growth rates differed from the start, averaging 2.23 mm/day in 1978, 2.06 mm/day in 1979 and 2.60 mm/day in 1981 (Table 1). The 1979 growth rate declined after the 12th week (84 days) to an average of 1.79 mm/day as compared to 2.24 mm/day in 1978 and 2.62 mm/day in 1981. The increase in growth rate for 1981 may reflect a maturing marsh and the maximum possible growth rate may not yet have been achieved. Observed growth rates are similar to those reported in other studies (Carbine 1941; Bryan 1967; Franklin and Smith 1963; Forney 1968; Fago 1977).

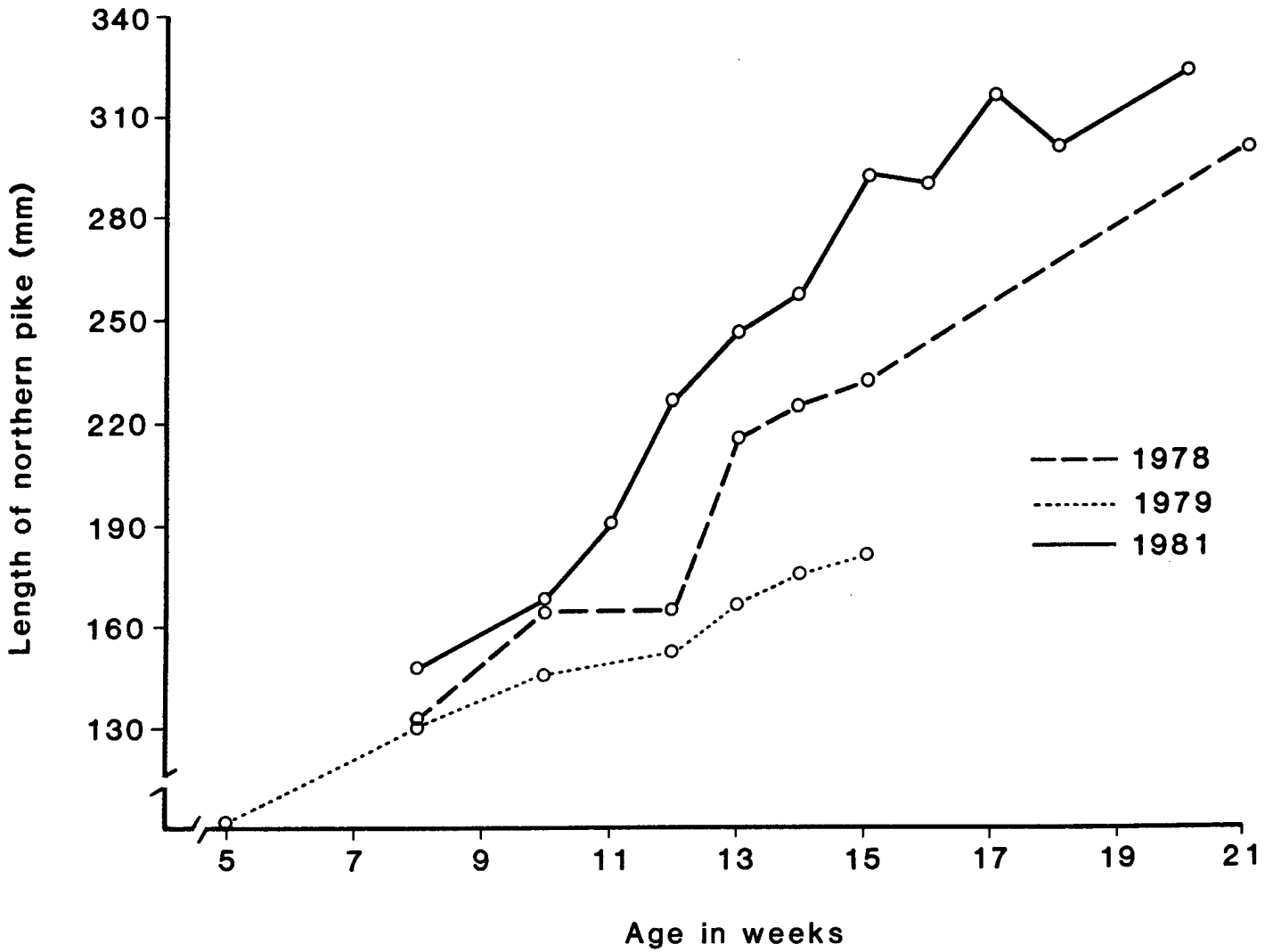

Figure 4. Observed growth of northern pike from the Decker pike marsh in 1978, 1979, and 1981, based upon samples taken from seines and the outlet trap.

Table 1. Growth rates of northern pike from the Decker Marsh, Montana 1978-1981.

Age (days)	Growth (mm/day)		
	1978	1979	1981
35	-	2.83	-
56	2.37	2.34	2.65
70	2.35	2.08	2.41
84	1.97	1.81	2.70
91	2.39	1.84	2.73
98	2.31	1.80	2.64
105	2.21	1.73	2.79
140	-	-	2.30
147	2.05	-	-

Food Habits

Periodic attempts were made in 1978 and 1979 to capture pike for determination of food habits. Few fish were captured in 1978 and the flood provided many food organisms, primarily other species of fish, which would not normally occur in the marsh. Seining during the 1979 rearing period was somewhat more successful and the information obtained from analysis of the stomachs of northern pike fingerlings is presented in Table 2.

Although sample size was small in some cases, a typical feeding pattern does emerge. In May, the primary food item was *Daphnia*; by late June the larger insects, such as Ephemeroptera, Coleoptera and Diptera were eaten. No detailed analysis of food habits, consumption rates or feeding sequences was attempted but the sequence of food item utilization is similar to that reported by Fago (1977) for the first four weeks of feeding by pike.

Production

Numbers of northern pike produced in 1979 exceeded 1978 numbers by 20-fold (Table 3). Yield in kg/ha was 4.4 times greater in 1979 (4.51 in 1978 and 19.92 in 1979). The number of fish produced showed a dramatic decline in 1980 to 0.34 kg/ha (18 fish). A combination of factors probably influenced the low number of pike reared in 1980. The lack of a constant water supply from the mine, and other difficulties discussed earlier, made it difficult to maintain a constant water level in the marsh. Also, heavy predation from adult pike left in the marsh may have been a factor. In 1981, the low production may have been influenced by high turbidity caused by wind action immediately after the fry were stocked. Also, the reservoir water level remained high until September, thus preventing marsh draining until that time. This, most likely, resulted in increased competition among fingerlings. However, mean length of fingerlings released was excellent.

Table 2. Pike fingerling stomach contents sampled in 1979 showing mean number (N) and 95% confidence limits (in parentheses) by major food groups.

Date	1979									
	5/30	6/8	6/15	6/22	6/28	7/6	7/12	7/19	7/28	8/2
N	11	5	4	8	10	8	8	9	10	4
Cladocera	25.9 (17.4-34.4)	2.8 (0-7.38)	2.8 (0-6.93)	0.3 (0-0.6)	0.3 (0-3.3)	1.1 (0-3.3)	1.1 (0-3.3)	1.1 (0-3.3)	1.1 (0-3.3)	1.1 (0-3.3)
Ceriodaphnia	3.0 (0.8-5.2)									
Cyclopiidae	1.1 (0.1-2.2)									
Ephemeroptera	0.1 (0-0.3)	0.6 (0-1.8)	3.0 (0.5-5.5)	0.6 (0-1.6)	9.9 (5.1-14.7)	1.2 (0.2-2.3)	1.8 (0.2-3.3)	15.1 (2.4-27.8)	17.7 (10.7-24.7)	16.0 (3.5-28.5)
Cooleoptera			6.2 (3.6-9.0)	5.1 (1.9-8.4)	1.9 (1.1-2.7)	2.4 (1.0-3.8)	4.1 (0-9.7)	6.9 (2.2-11.6)	1.3 (0.3-2.27)	0.8 (0-2.2)
Diptera	2.4 (1.0-3.8)	7.8 (2.5-13.1)	3.8 (0-8.2)	1.4 (0.4-2.4)	3.7 (1.5-5.9)	9.9 (4.6-15.2)	6.0 (2.5-9.5)	6.7 (1.3-12.0)	1.2 (0.3-2.1)	0.8 (0-1.7)
Odonata								0.1 (0-0.3)	1.5 (0.9-2.1)	0.5 (0-1.1)
Hemiptera				0.1 (0-0.4)	0.5 (0-1.0)		0.9 (0-1.9)		0.3 (0-0.7)	

Table 3. Comparative production of northern pike in the Decker Marsh, Montana, 1978-1981.

Year	Number Fry	Stocked Adults	Number Fingerlings Produced	Weeks in Marsh	Mean Length (mm)	Mean Weight (g)	kg/ha
1978	150,000	-	254	21	283.9	177.3	4.51
1979	175,000	-	5165	14	173.1	31.2	19.92
1980	-	9	18	16	271.0	169.2	0.34
1981	800,000	-	138	20	322.7	195.9	2.70

Remarkably few data are available quantifying pike production in controlled rearing marshes. Table 4 summarizes production figures from four natural marshes in three states. The 1979 production from the Decker marsh is the highest shown.

CONTRIBUTION TO RESERVOIR SPORT FISHERY

All fingerlings released from the marsh into the Tongue River Reservoir were marked with a pelvic fin clip (left in 1978, right in 1979 and left in 1980) for future identification. Gill net catch rates in 1980 reflected the addition of northern pike to the reservoir population. Northern pike contributed 1.0 fish/net in 1980 as compared to 0.1, 0.2, and 0.3 fish/net in 1975, 1976, and 1979, respectively. Over 88 percent of the northern pike taken were less than 560 mm in length (16 of 18), with an average length of 489 mm. Approximately 80 percent of the pike showed evidence of a right pelvic clip, although fin regeneration masked total recognition. Scale examination showed one annulus on fish ranging from 370-560 mm. Thus, it is likely that the 5,165 northerns released in 1979 contributed to the reservoir population.

Table 4. Northern pike production from four marshes in three States.

	Year	Average length (mm)	kg/ha
<u>New York</u>			
Oneida Lake (Forney 1968)	1964	36	7.64
	1965	36	3.59
	1966	46	6.85
<u>Wisconsin</u>			
Pleasant Lake (Fago 1977)	1970	91	2.47
	1971	81	8.29
	1972	100	15.24
Pabst Marsh (Fago 1977)	1971	96	7.86
	1972	108	16.40
<u>Montana</u>			
Decker Marsh	1978	284	4.51
	1979	173	19.92
	1981	323	2.70

IMPLEMENTATION OF WILDLIFE PLAN

An index of furbearer and waterfowl use was developed to determine if the marsh might provide additional benefits beyond the production of northern pike. Because the surveys were conducted only once each year with variable conditions, the summary which follows is presented for informational purposes only.

FURBEARER SURVEYS

Furbearer surveys were conducted during the falls of 1976-1979 and 1981 according to methods described in Appendix B. The diversity of furbearer sign in the prescribed proximity to the pike marsh is summarized in Table 5. Because of variation in tracking conditions and habitat use by each species, specific conclusions would not be valid. However, it appears that muskrat use of the area is on the decline, while use indices of other species seem relatively stable.

WATERFOWL USE

The seven nesting islands planned at the onset of this project could not be constructed until 1980. The nesting platforms described in Appendix B were installed in 1978, although no geese have been observed using them. The grass seed planted on the islands did not germinate during the fall of 1981. This was probably due to the lack of required rainfall.

Other measures to enhance waterfowl use were also implemented. During early spring 1981, Decker Coal Company planted 75 cottonwood saplings between Montana Highway 314 and the pike marsh. The objective was to create a barrier to reduce harassment and poaching of waterfowl using the pike marsh. Also, submergent and emergent aquatic vegetation has developed since initial construction; hence, good cover and forage are now available for waterfowl.

Several hundred Canada geese were observed using the marsh in 1981 but a precise estimate of the number was not attempted. Evidence of successful hatching of goose eggs was observed on three of the seven islands in 1981, with a single infertile egg found on a fourth island.

Table 5. Comparative density of beaver, muskrat, and mink sign per river kilometer on the study area near the Decker pike marsh.

Type of sign	Density of Sign per River Kilometer														
	Beaver (<i>Castor canadensis</i>)			Muskrat (<i>Ondatra zibethica</i>)			Mink (<i>Mustela vison</i>)								
	1976	1977	1978	1979	1981	1976	1977	1978	1979	1981	1976	1977	1978	1979	1981
Den															
Current	1.72(11)	1.56(10)	1.25(8)	1.25(8)	1.25(8)	1.09(7)	0.78(5)	0.31(2)	0.31(2)	--	0.31(2)	--	--	0.16(1)	--
01d	2.66(17)	2.19(14)	0.31(2)	0.78(5)	0.47(3)	1.88(12)	0.78(5)	0.62(4)	--	--	0.47(3)	0.31(2)	--	--	--
Cache															
Current	0.94(6)	0.63(4)	0.47(3)	0.47(3)	0.94(6)	--	--	--	--	--	--	--	--	--	--
01d	0.63(4)	0.16(1)	--	0.47(3)	0.16(1)	--	--	--	--	--	--	--	--	--	--
Scent mound															
	1.56(10)	1.25(8)	1.09(7)	--	--	0.16(1)	0.31(2)	--	--	--	--	--	--	--	--
Trail concentration (2 or more)															
Current	1.88(12)	2.50(16)	--	--	--	--	--	--	--	--	--	--	--	--	--
01d	--	0.94(16)	--	--	--	--	--	--	--	--	--	--	--	--	--
Trails (individual)															
Current	12.66(81)	10.00(64)	--	8.26(40)	--	--	--	--	0.16(1)	--	--	--	--	--	--
01d	1.88(12)	6.09(39)	--	--	--	--	--	--	--	--	--	--	--	--	--
Scats															
Current	--	0.16(1)	--	--	--	--	0.31(2)	--	--	--	0.63(4)	--	--	--	--
01d	--	--	--	--	--	--	--	--	--	--	0.63(4)	--	--	--	--
Track sets															
Current	--	--	--	--	--	2.34(15)	0.63(4)	1.56(10)	--	0.05(3)	2.03(13)	1.09(7)	3.33(20)	--	2.8(18)
01d	--	--	--	--	--	0.31(2)	0.78(5)	0.47(3)	--	--	0.31(2)	1.25(8)	1.88(12)	--	--

() Indicates number of observations.

MARSH WATER QUALITY

Initial design of the project allowed for all of the marsh water to be supplied by mine waste water inflow. Several factors, previously described, resulted in a mixture of approximately 80 percent mine waste water and 20 percent river water within the marsh. A synopsis of water inflow problems is as follows. Prior to May 1978, all water within the marsh was mine waste water. In May, the reservoir and river were in extreme flood stage and water flowed back through the outflow culvert and into the marsh. In 1979, it was necessary to supplement mine water with water from the Tongue River because the dike had developed leaks and water levels were impossible to maintain. As a result, "pure" mine decant water in the marsh was only present prior to May 1978.

Routine water samples were collected from the marsh during each year of the study (Appendix B). Analyses were conducted both in the field and in the laboratory according to methods described by Whalen and Leathe (1976). A relative indication of water chemistry in the marsh and for the mine water inflow is presented in Table 6. Although the data only represent one sampling date, differences in anion and cation concentrations between marsh inflow and the marsh are apparent. Greatest differences were found for Na, Fe, HCO_3 , which were at reduced levels in the marsh, and CO_3 and dissolved oxygen, which were greater in the marsh. Data collected on three occasions during 1979, when both mine water and river water were being added to the marsh, also indicate lower alkalinity and conductivity and higher dissolved oxygen and pH in the marsh as compared to marsh inflow. These data indicate better water quality conditions existed in the marsh and suggest that an improvement in water quality may occur as the water is retained in the marsh. Similar water quality improvements were well documented in the Decker sedimentation pond by Turbak et al. (1979). Further water chemistry data collections would have provided greater insight into the changes in the quality of mine effluent water after retention in the marsh. Such data were not collected, however, because the availability of pure mine water was not sufficient to maintain water levels in the marsh and because water quality had been deemed suitable for pike hatching and rearing.

It was also suggested in the literature that mine discharge water was not impacting the Tongue River. Whalen (1979) postulated that, although the mine discharge water had different chemical constituents than Tongue River water, it was not significantly affecting the river. Whalen measured all common anions and cations, manipulated the data to the most severe condition (maximum possible mine discharge) and calculated the theoretical increases in the river below the discharge. Based on these calculations, he concluded that the quality of river water would not be measurably altered. Furthermore, the mean contribution of mine discharge water to the river flow was only 0.09 percent throughout his study.

Table 6. Changes in water quality as a result of mine waste water being stored in the pike marsh. Samples were taken in March 1978. All values are expressed in mg/l and ml/l, unless otherwise noted.

Water quality parameters	Marsh inflow (mine waste water)	Marsh
Ca ⁺⁺	44.4	50.4
Mg ⁺⁺	45.0	27.6
Na ⁺	240.0	> 30.0
K ⁺	7.7	6.7
Fe	0.25	0.02
Si	18.8	12.4
Cl ⁻	6.5	4.5
F ⁻	1.19	0.77
SO ₄ ⁼	290.0	205.0
HCO ₃ ⁻	591.9	332.6
CO ₃ ⁻	0.0	6.9
DO	8.3	15.9
pH	7.8	8.6
Temp (° C)	14.8	16.5
Conductivity (μmhos·cm ⁻¹)	1410	890

A series of water quality measurements taken in 1978 are listed in Table 7. These data are included to provide a summary of representative water quality in the marsh throughout the study. At no time were there any indications that water in the marsh was unsuitable for the well-being of northern pike fry and fingerlings.

Table 7. Selected water quality parameters of Decker Marsh measured in 1978. Changes in water quality due to flood water dilution in mid-May are illustrated.

Date	Temperature (° C)	Dissolved oxygen (mg/l)	pH	Alkalinity (mg/l CaCO ₃)	Conductance (μmhos/cm)	Depth (cm)
4/12	-	10.2	8.67	365	-	-
4/19	-	10.2	8.79	-	-	-
4/21	10	-	-	-	-	-
4/24	12	-	-	-	-	45
4/26	12	10.4	8.85	379	1600	38
5/1	14	9.1	8.84	420	1675	66
5/10	16	10.4	9.00	475	1700	66
5/15	23	10.3	9.09	506	1775	80
5/26	22	7.4	-	225	1025	236
6/2	18	7.6	-	265	1000	219
6/9	24	6.9	8.48	230	1000	212
6/15	25	6.8	8.45	268	900	206
6/23	25	7.5	8.59	237	1025	201
7/1	27	7.2	8.60	254	1100	163
7/7	26	6.8	8.61	261	1100	179
7/13	26	6.8	8.54	251	1125	168
7/21	21	6.0	8.45	264	1075	171
7/28	25	8.5	8.69	275	1175	147
8/4	26	7.7	8.61	311	1200	-
8/12	30	7.5	-	277	1250	-
8/18	19	7.4	8.60	272	1250	-
8/25	26	6.4	8.65	285	1325	-
9/1	26	14.1	8.95	302	1425	-

DISCUSSION

From the preliminary fertilization and hatching experiments conducted in pure mine decant water through the natural spawning of adults in the marsh, this project has demonstrated a beneficial use of surface coal mine discharge water. Although altered chemically, the water discharged from the Decker Coal mine was of sufficient quality to allow fertilization and hatching of northern pike eggs as well as good growth and survival of juvenile pike.

With proper planning, marsh construction techniques, and sound marsh management practices, the problems discussed earlier could be avoided. And the results of this project could be applied in selected areas throughout the Northern Great Plains. However, preliminary measurements on water quantity and quality are essential prior to such an investment of time and money.

In addition to demonstrating a beneficial use of coal mine discharge water, the other major objective was to contribute to the northern pike sport fishery in the Tongue River Reservoir. The periodic creel checks were conducted during this project and indicated a numerical increase in the 1981 catch rate for northern pike, compared to the rates for 1975 and 1976, however the data were too limited for statistical analysis. Creel surveys should be conducted in succeeding years before definitive conclusions can be drawn relative to the impact of marsh-produced pike on sport fish harvest. When pike production in the marsh reaches its full potential, it is believed that these fish will contribute measurably to the sport fish catch in the reservoir.

Although the gill netting data discussed earlier provides only an index of preliminary species composition, similar indicies have been obtained on this fishery for many years and we believe pike populations have been increased in the reservoir as a result of this project.

While the study was originally designed to evaluate the marsh as a spawning area for northern pike, the problems, time, and expense associated with capturing and subsequently removing the adults from the marsh, coupled with the low production of fingerlings in 1980, strongly favored managing the marsh as a rearing facility. Even if natural spawning in the marsh equaled production from fry stocking, fry rearing is a much more cost effective use of the marsh.

Based on pike production figures from the marsh, there appears to be considerable potential for selective enhancement of local fisheries through similar operations in the Northern Great Plains.

SUMMARY OF PIKE MARSH PROJECT

The major findings of this demonstration project are as follows:

1. Studies on the water chemistry at the Decker Coal mine pond indicated that waste water in the sedimentation pond was of sufficient quality to support the aquatic life considered in this study.
2. Northern pike eggs were fertilized, water-hardened and hatched in effluent water from the Decker Coal mine with no observed adverse effects. A 50-60 percent hatch resulted, which compares favorably with standard hatchery operations with northern pike.
3. Fish hatched in these experiments and reared for 5 months in the Decker sedimentation pond showed good growth. They demonstrated a slightly faster rate of mercury accumulation than reservoir fish, but amounts were below EPA and U.S. Food and Drug Administration critical levels.
4. Mine discharge water used to fill the pike marsh provides a potential for improved water quality after storage in the marsh, particularly in regards to sodium, iron, sulfate and conductivity.
5. Pike fry stocked in the marsh in 1978 and 1979 produced 4.51 and 19.92 kg/ha, respectively. The 1979 production exceeded production figures reported for most pike marshes elsewhere in the United States.
6. The adults stocked in 1980 produced only 18 fingerlings (0.34 kg/ha) and required many more man-days of effort than the fry stocking in 1978 and 1979. The poor success may have been influenced by a lack of suitable spawning substrate and low number of spawners. However, stocking and removing adults is not a successful technique when compared to fry stocking.
7. After pike produced in the marsh were released into the reservoir gill net catches increased from 0.1, 0.2 and 0.3 fish/net in 1975, 1976, and 1979, respectively, to 1.0 fish/net in 1980. This demonstrates a likely contribution of marsh produced pike to the sport fishery of the Tongue River Reservoir.

RECOMMENDATIONS

There are several important recommendations for potential operators of marsh projects:

1. Obtain the services of a contractor experienced in pond/marsh design and construction.
2. Construct and fill the marsh about one year in advance of stocking adults or fry. This should allow adequate time for development of an invertebrate community and to establish submergent aquatic vegetation.
3. Prevent contamination of the marsh with fish species other than those that may be added as forage. This will eliminate interspecific competition and should contribute to a higher survival rate.
4. Make certain that an adequate and reliable source of water is available for filling the marsh and maintaining water levels throughout the fish rearing period.
5. Establish some sort of cooperative agreement between the industry and the local conservation agency, designating who will operate the marsh after the initial testing period is completed. For example, the Decker Marsh will be operated in the future by Decker Coal Company biologists, in close cooperation with Montana Fish, Wildlife and Parks Department.
6. Consider using the marsh for rearing fry obtained elsewhere because of the time and expense of trapping adults for the marsh and the need to remove them again after spawning.
7. Evaluate the contribution of fish reared in the marsh to the fish population and/or sport fish harvest in the water(s) where they are stocked. Without this evaluation, private and governmental operators cannot determine whether or not such a project is beneficial.

REFERENCES

- Adelman, I. R., and L. L. Smith, Jr. 1970a. Effect of oxygen on growth and food conversion efficiency of northern pike. *Prog. Fish Cult.* 32(2):93-96.
- _____. 1970b. Effect of hydrogen sulfide on northern pike eggs and sac fry. *Trans. Am. Fish. Soc.* 99(3):501-509.
- American Public Health Association. 1971. Standard methods for the examination of water and wastewater. 13th ed. Am. Public Health Assoc., New York. 874 pp.
- Beyerle, G. B., and J. E. Williams. 1973. Contribution of northern pike fingerlings raised in a managed marsh to the pike population of an adjacent lake. *Prog. Fish Cult.* 35:99-103.
- Bryan, J. E. 1967. Northern pike production in Phaley Pond, Minnesota. *J. Minn. Acad. Sci.* 34:101-109.
- Brynildson, C. 1958. What's happening to northern pike spawning grounds? *Wis. Conserv. Bull.* 23:1-3.
- Carbine, W. F. 1941. Observations on the life history of the northern pike Exos lucius L., in Houghton Lake, Michigan. *Trans. Am. Fish. Soc.* 71:149-164.
- Chapman, D. G., and W. S. Overton. 1966. Estimating and testing differences between population levels by the Schnabel method. *J. Wildl. Manage.* 39(1):173-180.
- Elser, A. A., R. C. McFarland, and D. Schwehr. 1977. Effect of altered streamflow on fish of the Yellowstone and Tongue Rivers, Montana. Old West Regional Comm.; Yellowstone Impact Study, Tech. Rept. 8, 180 pp.
- Emboly, G. C. 1918. Artificial hybrids between pike and pickerel. *J. Hered.* 9:253-256.
- Fabricius, E., and K. J. Gustafson. 1958. Some new observations on the spawning behavior of the pike, Exos lucius L. *Fish Bd. Sweden, Inst. Freshwater Res., Drottningholm* 39:23-54.

- Fago, D. M. 1977. Northern pike production in managed spawning and rearing marshes. Wis. Dept. Nat. Resour. Tech. Bull. 96. 30 pp.
- Food and Drug Administration. 1974. Poisonous or deleterious substrates in peanuts, evaporated milk, fish and shellfish. Proposed rules, Fed. Register. December 6, 1974. Washington, DC (As cited in Red Book).
- Forney, J. L. 1968. Production of young northern pike in a regulated marsh. New York Fish Game J. 15:143-154.
- Franklin, D. R., and L. L. Smith, Jr. 1963. Early life history of the northern pike, Esox lucius L., with special reference to the factors influencing the numerical strength of year classes. Trans. Am. Fish. Soc. 92:91-110.
- Frost, W. E. 1954. The food of pike, Esox lucius L., in Windemere. J. Anim. Ecol. 23:339-360.
- Hassler, T. J. 1970. Environmental influences on early development and year-class strength of northern pike in Lakes Oahe and Sharpe, South Dakota. Trans. Am. Fish. Soc. 99:369-375.
- Hunt, B. P., and W. F. Carbine. 1951. Food of young pike, Esox lucius L., and associated fishes in Peterson's Ditches, Houghton Lake, Michigan. Trans. Am. Fish. Soc. 80:67-83.
- Johnson, F. H. 1956. Northern pike year-class strength and spring water levels. Trans. Am. Fish. Soc. 86:285-293.
- McCarragher, D. B. 1957. The natural propagation of northern pike in small drainable ponds. Prog. Fish Cult. 16:89-90.
- McCarragher, D. B. 1962. Northern pike, Esox lucius, in alkaline lakes of Nebraska. Trans. Am. Fish. Soc. 91:326-329.
- Phillips, G. R. 1978. The potential for long-term mercury contamination of the Tongue River Reservoir resulting from surface coal mining. Final Report, U.S. Fish Wildl. Serv., Western Energy and Land Use Team. Ft. Collins, CO. 53 pp. (mimeo report).
- Phillips, G. R., and R. W. Gregory. 1980. Accumulation of selected elements (As, Cu, Hg, Pb, Se, Zn) by northern pike (Esox lucius) reared in surface coal mine decant water. Proc. Montana Acad. Sci. 39:44-50.
- Phillips, G. R., T. E. Lenhart, and R. W. Gregory. 1980. Relation between trophic position and mercury accumulation among fishes from the Tongue River, Montana. Env. Res. 22:73-80.
- Priegel, G. R., and D. Krohn. 1975. Characteristics of a northern pike spawning population. Wis. Dept. Nat. Resour. Tech. Bull. 86. 18 pp.

- Royer, L. M. 1971. Comparative production of pike fingerlings from adult spawners and from fry planted in a controlled spawning marsh. *Prog. Fish Cult.* 33:153-155.
- Schneider, J. C. 1971. Characteristics of a population of warm-water fish in a southern Michigan Lake, 1964-1979. Michigan Dept. of Nat. Resourc., Res. and Dev. Rept. 230. 15 pp.
- Scott, W. B., and E. J. Crossman. 1973. Freshwater fishes of Canada. *Fish. Res. Bd. Can. Bull.* 184. 966 pp.
- Snow, H. E., and T. D. Beard. 1972. A ten-year study of native northern pike in Bucks Lake, Wisconsin. *Wis. Dept. of Nat. Resourc., Tech. Bull.* 56. 20 pp.
- Turbak, S. C., G. J. Olson, and G. A. McFeters. 1979. Impact of western coal mining - 1. Chemical investigations of a surface coal mine sedimentation pond. *Water Res.* 13:1023-1031.
- Van Voast, W. A., and R. B. Hedges. 1975. Hydrologic aspects of existing and proposed strip coal mines near Decker, southeastern Montana. *Mont. Bur. Mines and Geol. Bull.* 93. 31 pp.
- Whalen, S. C. 1979. The chemical limnology and limnotic primary production of the Tongue River Reservoir, Montana. M.S. thesis, Mont. State Univ., Bozeman. 205 pp.
- Whalen, S. C., and S. A. Leathe. 1976. Limnology of the Tongue River Reservoir; existing and potential impact of coal strip mining. Third Progress Report. *Mont. Coop. Fish Res. Unit, Mont. State Univ., Bozeman.* 64 pp.
- Yoakum, J., and W. P. Dasmann. 1969. Habitat manipulation practices. Pages 173-231 in R. H. Giles, ed. *Wildlife management techniques.* 3rd Edition. The Wildlife Society, Washington, DC.

APPENDIX A. HISTORY OF THE TONGUE RIVER RESERVOIR FISHERY

The Tongue River Reservoir and a portion of the drainage upstream were chemically treated in 1957 to remove undesirable fish species. Following rehabilitation, the reservoir was stocked with rainbow trout in an attempt to provide the excellent fishing which commonly follows the initial impounding of reservoirs. Over two million fingerling rainbow trout were planted from 1953-1960. Initial survival was good and gill net sampling in 1959 produced 80 trout per net night. Catches dropped off in 1960, however, and gill net samples produced only seven trout per night. As population levels of undesirable fish increased, trout stocking was discontinued. However, correspondence with local fishermen in 1962 suggests that the reservoir was still producing some good catches of rainbow trout, with 0.7 to 2.7 kg (1½ to 6 lbs) of fish taken per angler.

Stocking recommendations for a warm-water fishery in the reservoir were implemented in 1963 and are summarized in Table A-1. Northern pike fry and fingerlings were planted from 1963 through 1966 in an attempt to develop a self-sustaining population. Northerns were not stocked in 1967 and 1968 to check on natural reproduction, but were again planted from 1969-1977. Fingerlings were substituted for fry from 1972-1977. Channel catfish were introduced in 1963 and 1964, and largemouth bass were planted in 1964 and again in 1972 and 1973. Walleye were stocked from 1965 to 1969. Because the first walleye plant would have matured in 1970, this plant was discontinued. Walleyes were planted again in 1980 to supplement natural reproduction.

Northern pike and walleye are the species most desired by anglers. Growth of both species in the reservoir is good; walleye up to 5.5 kg and northerns to 11.5 kg are available to anglers. Although walleyes have been spawning successfully in the reservoir, physical characteristics and water level fluctuations in the reservoir have resulted in a limited amount of suitable northern spawning habitat. Spawning areas are present only during maximum storage. The natural reproduction has not been documented.

GILL NET CATCH RATES

Fish population trends were followed from 1964-1980, with the aid of experimental gill nets. A total of 21 species of fish, representing eight families, were caught in the reservoir. Total catch per net night ranged from a low of 27.6 in 1971 to a high of 74.8 in 1964. White crappie dominated the catch in 10 of the 13 sampling periods. Game fish generally made up less than 10 percent of the total catch, with walleye the dominant game species.

Table A-1. Summary of warmwater fish stocking in the Tongue River Reservoir, 1963-1980.

Year	Species	Size	Number
1963	Northern pike	Fry	210,000
	Northern pike	Fingerling	35,200
	Channel catfish	7.5 cm	20,608
1964	Northern pike	Fry	100,000
	Channel catfish	5 cm	99,180
	Largemouth bass	2.5 cm	150,000
1965	Northern pike	Fry	339,300
	Walleye	Fry	750,000
1966	Northern pike	Fry	210,500
	Walleye	Fry	100,000
1967	Walleye	Fry	197,750
1968	Walleye	Fry	601,214
1969	Northern pike	Fry	650,000
	Northern pike	Fingerling	513,200
	Walleye	Fry	92,480
1970	Northern pike	Fry	1,125,000
1971	Northern pike	Fry	360,000
1972	Northern pike	Fingerling	14,058
	Largemouth bass	5 cm	199,290
1973	Northern pike	Fingerling	13,184
	Largemouth bass	5 cm	27,540
1974	Northern pike	Fingerling	3,330
1975	Northern pike	Fingerling	32,775
1976	Northern pike	Fingerling	50,000
1977	Northern pike	Fingerling	20,120
1980	Walleye	Fry	250,000

The lack of suitable spawning habitat, coupled with improper water level management, resulted in a low population level of northern pike. Catch rates from gill nets in 1975, 1976, 1979 and 1980 were 0.1, 0.2, 0.3, and 1.0 fish/net night (\approx 14 hrs/night), respectively. The increase in 1980 was made up of yearling fish, with 88.9 percent (16 of 18) of the northern pike in age class I.

POPULATION ESTIMATES

A population estimate, based on trap-netted fish, was calculated for northern pike in the years 1974-1976, utilizing a modified Schnabel estimator (Chapman and Overton 1966). Estimates of northern pike greater than 275 mm were 272 in 1974, 228 in 1975, and 138 in 1976 (Elser et al. 1977). The statistics are shown in Table A-2. Based on average weight of trap-netted fish, the standing crop of northern pike was estimated at 0.56 kg/ha (0.50 lb/acre), 0.50 kg/ha (0.44 lb/acre), and 0.315 kg/ha (0.28 lb/acre) in 1974, 1975, and 1976, respectively.

The standing crop of northern pike in the Tongue River Reservoir is considerably lower than most reported population levels. For example, estimates of standing crops of northern pike in Wisconsin lakes ranged upward from 0.67 kg/ha (Snow and Beard 1972); in a southern Michigan lake, crops ranged from 3.5-5.3 kg/ha (Schneider 1971). Scott and Crossman (1973) reported that standing crops of northern pike from various habitats across North America generally range between 1.5 and 4.6 kg/ha. Low population levels in the Tongue River Reservoir were probably the result of poor habitat quality and the lack of natural reproduction.

Table A-2. Population estimates of northern pike from trap net catches, Tongue River Reservoir, 1974-1976 (from Elser et al. 1977).

Year	Number examined	Number recaptured	Population estimate	Confidence interval (95%)
1974	169	36	272	a
1975	180	52	228	218-238
1976	85	48	138	116-172

^aConfidence interval not computed in 1974 due to variation in recapture data.

APPENDIX B. STUDY METHODS

WATER QUALITY

Water samples were collected at twice-monthly intervals from a permanent sampling station near the marsh outflow gate. Water samples were also obtained from the inflow of mine waste water when it was flowing. Samples were taken with a 5-liter Van Dorn bottle or directly into 300 ml sample bottles.

Temperature and dissolved oxygen determinations were made immediately following sample collection. An E. H. Sargent and Co. (range: 10-100° C) mercury thermometer was used for temperature measurements and the Alsterberg Azide Modification of the Winkler Method was used for dissolved oxygen (American Public Health Association 1971).

Specific conductance was measured at a frequency of 60 cps with a Yellow Springs Instrument Co., Inc. (YSI) Model 31 AC conductivity bridge equipped with a YSI Model 3401 dipping cell. The hydrogen ion concentration (pH) was determined with a Beckman Model 76 Expanded Scale pH Meter.

Alkalinity was determined potentiometrically (American Public Health Association, 1971) using 0.1 N standard H_2SO_4 as a titrant. A pH of 8.3 was chosen as the carbonate end point and a pH of 4.5 was selected as the bicarbonate end point (Whalen 1979). Total alkalinity was expressed as $mg.l^{-1} CaCO_3$.

PIKE SAMPLING

Weekly attempts were made to sample marsh northern pike fingerlings by seining to monitor growth rate, food habits, and heavy metal uptake. Two seines were used: 30.5 m x 1 m (13 mm mesh) and a 7.6 m x 1 m (9 mm mesh).

Northern pike fingerlings migrating from the marsh to the reservoir were to be collected in the inclined plane trap, counted and allowed to enter the nearby Tongue River through a channel constructed beneath the marsh overflow point and the river. However, water flow from the mine was erratic and a constant overflow could not be maintained. In addition, as described within the text, the marsh could not be totally drained, even when all stop logs were removed, due to a surveying error. Thus, a combination of methods including seining, electrofishing, trap netting and, finally, rotenone were employed to remove fish from the marsh in the fall of both 1978 and 1979.

WILDLIFE OBSERVATIONS

Because this aspect of the study was ancillary to the primary objectives, visual observations and direct counts were used to evaluate wildlife use of the study area. The furbearer survey was conducted by two observers who walked both shores of the Tongue River from 3.2 kilometers south to a point 3.2 kilometers north of the marsh. The location and number of mink, beaver and muskrat marks were recorded on a field map. Also recorded were location of scats, dens, and caches. The first year of the study included the use of a boat, but foot travel alone was judged to be adequate for index data.

The waterfowl nesting platforms were constructed of marine plywood and 2" x 4"'s, as described by Yoakum and Dasmann (1969). Straw was placed in each platform for use as nesting material after platforms were secured to selected dead tree trunks. The trunks were sawed off for ease in securing the platforms.

APPENDIX C. REVIEW OF PIKE PRODUCTION IN MARSHES

This section reviews past attempts at managing natural marshes for northern pike production.

HABITAT DESCRIPTION

Marsh characteristics and management can, of course, affect pike production. Franklin and Smith (1963) stressed the importance of the shape of the slough. Flat basins are undesirable because small changes in water level can expose large areas of bottom. Shoreline slopes that are too steep are also undesirable because permanent potholes may be formed when water levels are raised and stabilized. Furthermore, the slough bed should be above normal lake levels so that it can be drained completely to allow the removal of all pike and to permit the annual reestablishment of terrestrial vegetation. An adequate water supply is necessary to ensure control of water levels and manipulation of flow. Chemical control of undesirable vegetation and encouragement of more useful species by drainage and planting may be required in some marshes. Grasses, sedges or rushes with fine leaves appear to promote pike productivity (Franklin and Smith 1963; Fago 1977).

PIKE PRODUCTION

Northern pike enter marshes to spawn in the spring soon after iceout, usually in April or early May when water temperatures are 8-12° C (Fabricius and Gustafson 1958; Franklin and Smith 1963; Preigel and Krohn 1975) and sometimes at temperatures less than 8° C.

Spawning takes place during daylight over heavy vegetation. Temperature, daily light intensity, and presence of suitable vegetation work together to stimulate spawning (Fabricius and Gustafson 1958). Dense growths of grasses and sedges typically found in floodplains and marshes are selected by pike for spawning. The duration of the spawning period is reported to range from a few days to a month or more. Franklin and Smith (1963) noted spawning periods of from 4-19 days at Lake George, Minnesota, with cold weather causing more protracted spawning. Adults leave the marshes soon after spawning, although some may linger for up to several weeks. The eggs usually hatch in 12-14 days at prevailing temperatures of 7-16° C. Approximately 117 to 150 degree days (i.e., 15° x 10 days = 150 degree days) above 0° C are required for hatching (Franklin and Smith 1963). At hatching, the young are 6-8 mm in length. They remain inactive and attached to vegetation from 6-10 days, while absorbing their yolk sac.

FEEDING AND EARLY LIFE HISTORY

Feeding begins approximately 10 days after hatching when fish reach a length of 10-12.5 mm (Hunt and Carbine 1951; Frost 1954; Franklin and Smith 1963; Priegel and Krohn 1975). Franklin and Smith (1963) found that the smallest pike with food present in the digestive tract was 10.3 mm long, and only 12.6 percent of fish 10-12.3 mm long had ingested food. Several authors (Embrey 1918; Hunt and Carbine 1951; McCarraher 1957) report a consistent feeding succession by young pike as they grow in the marshes. Microcrustacea are consumed initially, followed by heavy predation on aquatic insects. Thereafter, fish, including pike, constitute the bulk of the ration. Frost (1954), however, found that Lake Windermere pike did not consume insects, but progressed directly from zooplankton to fish. Franklin and Smith (1963) and Priegel and Krohn (1975) noted very low rates of piscivory in managed marshes, possibly in response to high insect abundance. Hunt and Carbine (1951) reported cannibalism at a minimum size of 21 mm, with 13.3 percent of pike over 21 mm being cannibalistic. Fago (1977) detected cannibalism in pike as small as 38 mm and noted that pike was one of the most important food items in the diet of fingerlings. McCarraher (1957) noted that, unless pike fingerlings are cropped by the time they reach 50 mm in length, cannibalism will greatly reduce marsh pike production. Attempted cannibalism was often observed by Fago (1977). However, attempts were frequently unsuccessful, leaving injured and possibly dying prey. Bryan (1967) noted similar behavior. The effects of cannibalism on northern pike production, however, have not been fully assessed.

Having attained a length of 50 mm, pike can be considered opportunistic carnivores (Scott and Crossman 1973). Fish constitute the bulk of the diet in 50 mm and larger fish, although frogs and crayfish may also contribute a significant portion. Competition for invertebrate food by pike fingerlings and other fish species was reported by Hunt and Carbine (1951). The exclusion of other fish species from pike rearing marshes may, therefore, ensure better pike survival and growth.

Fingerling pike in rearing marshes may be preyed upon by a variety of predators, including fish, frogs, turtles, birds, predaceous aquatic insect larvae and mammals (McCarraher 1957; Priegel and Krohn 1975). Hunt and Carbine (1951) noted significant predation on larval pike by yellow perch in a Houghton Lake, Michigan, rearing marsh. Franklin and Smith (1963) considered predation on fingerling pike by leopard frogs (*Rana pipiens*) and dysticid larvae relatively insignificant in their Lake George, Minnesota, study slough.

Where passage to the main body of water is unimpeded, emigration from the marsh commences approximately 16-24 days post hatching, after they have reached a length of approximately 20 mm (Hunt and Carbine 1951; Franklin and Smith 1963; Forney 1968). Pike leave the marsh only during daylight hours (Hunt and Carbine 1951; Franklin and Smith 1963) and emigration may be delayed in years typified by heavy cloud cover.

FINGERLING GROWTH

Carbine (1941) reported average growth rates of approximately 2.6 and 1.6 mm/day for fish over 20 mm in length from the Houghton Lake, Michigan, slough during the two years studied. Bryan (1967) found growth rates of 0.67 mm/day for fish up to 22 mm in length in Phaley Pond, Minnesota. Franklin and Smith (1963) gave growth rates that ranged from 0.5 to 2.3 mm/day, depending on age of the fish. Forney (1968) reported growth rates of 2.4 mm/day for pike over 20 mm in length from the Lake Oneida marsh, and Fago (1977) found an average growth rate of 2.64 mm/day and 2.17 mm/day for Pleasant Lake and Pabst marshes in Wisconsin, respectively.

FACTORS CAUSING MORTALITY

A number of physical and chemical factors can affect the productivity of northern pike rearing marshes. Probably the most important among these are water depth and water temperature. Large year classes have been associated with stable or rising water levels and temperatures in a number of studies (Johnson 1956; Franklin and Smith 1963; Forney 1968; Hassler 1970; Priegel and Krohn 1975). Declines in water levels during egg incubation may expose much of the marsh bottom, resulting in dessication of eggs. Inadequate water supplies may also cause the premature emigration of fingerlings from marshes, resulting in increased predation of the cohort in the main lake or river. Crowding of fingerlings in remaining marsh areas may promote increased competition for food, cannibalism, and predation by birds. Water level fluctuations were cited in several studies as the possible cause of poor annual marsh production (Johnson 1956; Franklin and Smith 1963; Forney 1968; Hassler 1970).

Rapid fluctuations in temperature also cause mortality (Franklin and Smith 1963; Hassler 1970; Priegel and Krohn 1975). Lowest survival in Lake George, Minnesota, fingerling pike cohorts was noted when maximum rate of temperature fluctuation reached 1.7° C/hour (Franklin and Smith 1963). Hassler (1970) reported mortality approaching 100 percent during early embryonic development when water temperature rapidly dropped below 10° C or when temperatures remained near 5° C for prolonged periods.

Low oxygen concentrations have also been implicated as causing decreased survival of eggs and fingerlings (Royer 1971; Priegel and Krohn 1975), especially because low oxygen is correlated with high water temperatures. Adelman and Smith (1970a) found that, at constant temperatures, low oxygen concentrations decreased growth rates in young pike. A gradual decrease in growth rate was noted as oxygen concentration was reduced to 3-4 ppm, with a quick decrease in growth rates reached at lower levels. Decreased growth rates were primarily the result of reduced food consumption at lower oxygen tensions.

Hydrogen sulfide (H₂S), commonly present in natural sloughs, also affects pike growth and survival. Adelman and Smith (1970b) found that eggs subjected to hydrogen sulfide had more anatomical malformation than controls. Fry hatched at smaller sizes and grew more slowly when exposed to hydrogen sulfide. The maximum possible safe levels of hydrogen sulfide for a 96-hour exposure

were 0.014-0.018 mg/l for pike eggs and 0.004-0.006 mg/l for sac fry. Other factors reported to affect pike production include alkalinity (McCarragher 1962), iron concentration (Franklin and Smith 1963), and sedimentation (Hassler 1970). However, quantitative relationships of many environmental characteristics to survival of young pike in marshes have not been defined. Clearly, extremes of most any environmental parameter may result in decreased pike survival.

MARSH MANAGEMENT CONSIDERATIONS

Fago (1977) noted the importance of time of drainage in controlled marshes. Drainage should be accomplished when water temperatures are below 21° C and oxygen concentrations are above 5 ppm to reduce stress on the pike fingerlings. If marshes are to be stocked "naturally" through spawning, as opposed to stocking of fry, large females (over 60 cm) are preferable, because more eggs can be produced from fewer brood fish. One suggested stocking rate is 11 - 17 kg of females per hectare, with 2 to 3 males per female and with males at least 50 cm in total length (Fago 1977). All spawners should be removed as soon as possible after spawning to prevent predation on the young fingerlings.

Forney (1968) looked at the recovery of marked pike in Oneida Lake, New York, and found that few pike survived that were less than 65 mm long when they left the marsh. Thus, the maintenance of pike populations in many lakes may depend primarily on producing large juvenile fish in nursery areas. On the other hand, retention of fingerlings in marshes until they reach a desired size may result in a smaller number of fish produced, primarily due to cannibalism (Fago 1977).

The effectiveness of marsh management has been shown by Beyerle and Williams (1973), who reported that pike raised in a managed marsh, constituted 62 percent of the total angling catch in Long Lake, Michigan. Thus, managed marshes can contribute significantly to pike fisheries in some situations.

APPENDIX D. MARSH DIKE AND IRRIGATION HEAD GATE VALVE DIAGRAMS

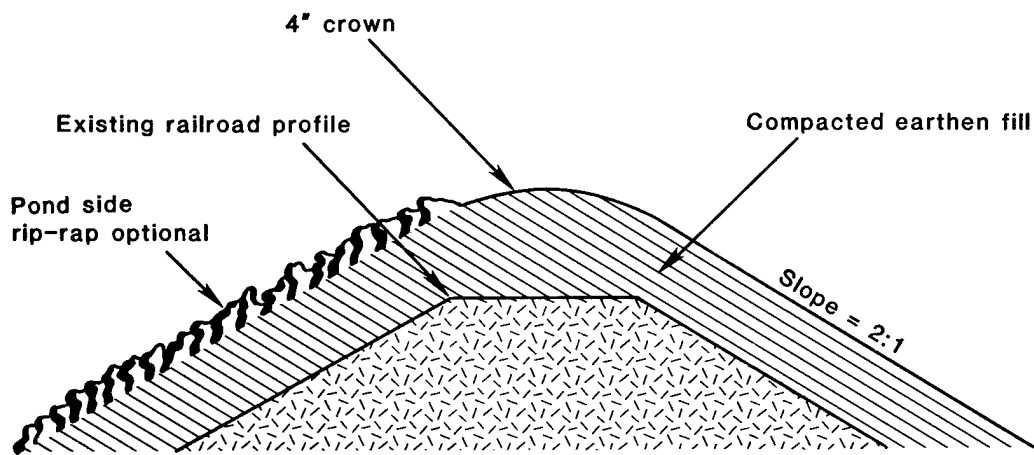

Figure D-1. Typical cross section of proposed dike (not drawn to scale).

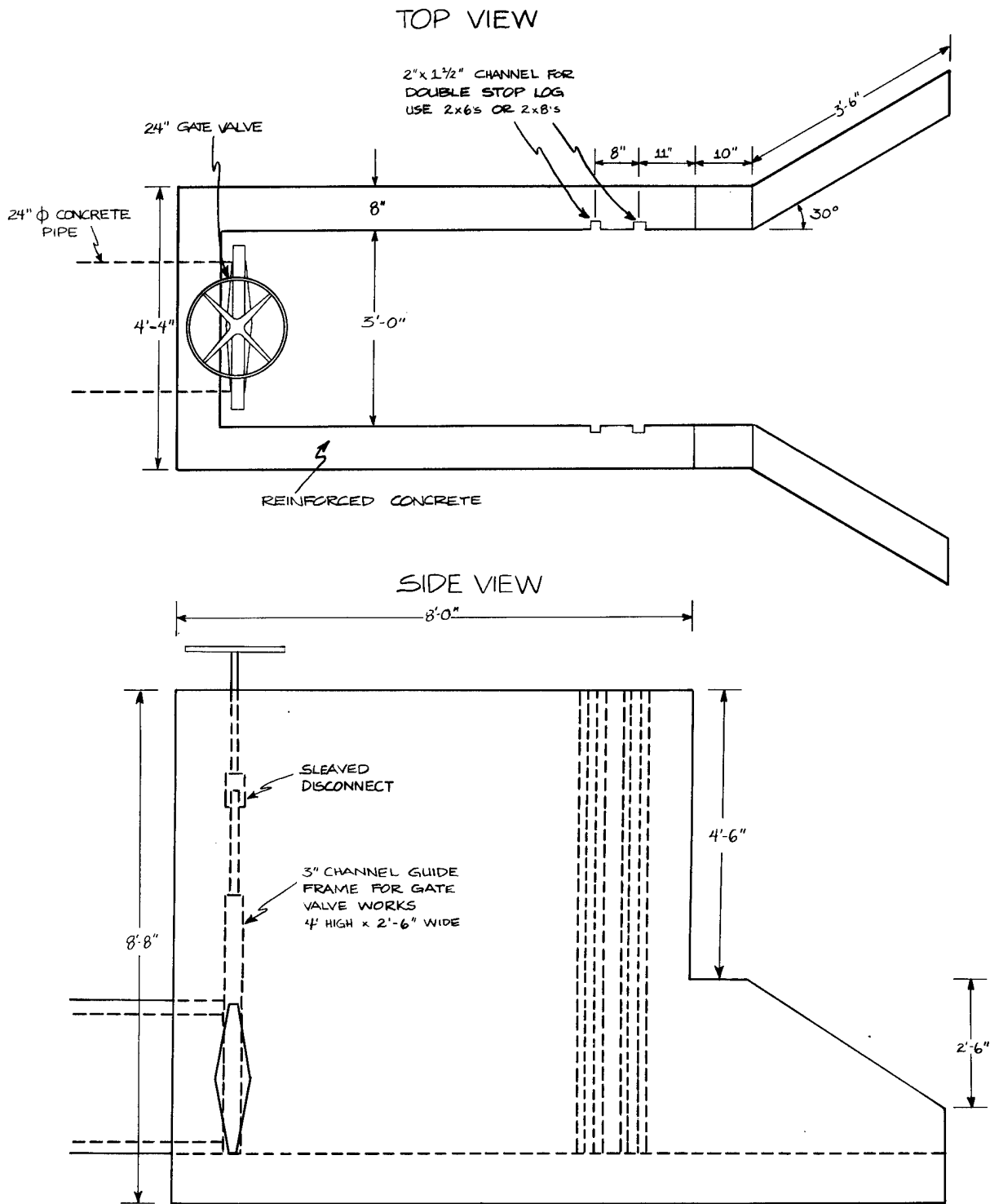
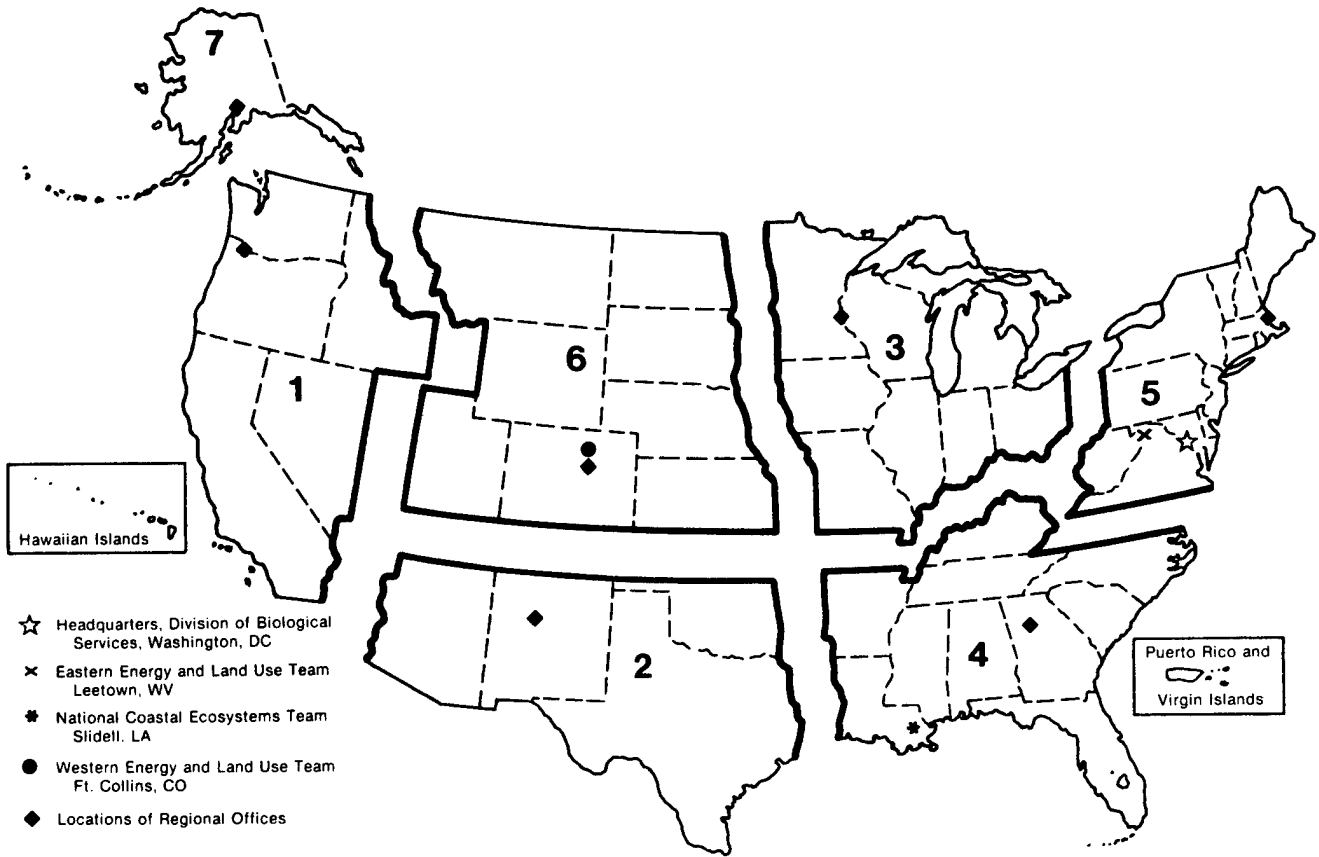

Figure D-2. Pike spawning marsh concrete gate outlet works with top and side views (not drawn to scale).

REPORT DOCUMENTATION PAGE		1. REPORT NO. FWS/OBS-84/03	2.	3. Recipient's Accession No.	
4. Title and Subtitle Utilization of Surface Coal Mine Waste for Construction of a Northern Pike Spawning/Rearing Marsh				5. Report Date April 1984	
7. Author(s) Richard W. Gregory, Allen A. Elser and Thomas Lenhart				6.	
9. Performing Organization Name and Address • Coop. Fish. and Wildl. Res. Unit • Dept. of Fish, Wildl. and Parks Univ. of Florida P.O. Box 430 Gainesville, FL 59301 Miles City, MT 59301 • Coop. Fish. Res. Unit Dept. of Biology, Montana State Univ., Bozeman, MT 59717				10. Project/Task/Work Unit No.	
				11. Contract(C) or Grant(G) No. (C) (G)	
12. Sponsoring Organization Name and Address Wetlands Ecology Group Fish and Wildlife Service Western Energy and Land Use Team U.S. Dept. of Interior Division of Biological Services Washington, D.C. 20240 Research and Development				13. Type of Report & Period Covered	
				14.	
15. Supplementary Notes					
16. Abstract (Limit: 200 words) As the limited water resources of the western United States are developed for agricultural and industrial uses, there is an ever increasing need to utilize waste water to its fullest potential. This report describes one example where waste water from an energy development site (coal mine operation) was used to enhance the fisheries of an adjacent reservoir. The details of this report provide an example of what considerations may be necessary for similar projects; illustrate potential problem areas in the planning, construction and operation of such a project; and stimulate ideas for developing other innovative uses of waste water for fish and wildlife habitat enhancement.					
17. Document Analysis a. Descriptors Fisheries Mining Water quality Waste water b. Identifiers/Open-Ended Terms Northern pike Exos lucius Marsh construction Sport fisheries Coal mining c. COSATI Field/Group					
18. Availability Statement Release Unlimited		19. Security Class (This Report) Unclassified		21. No. of Pages 44	
		20. Security Class (This Page) Unclassified		22. Price	



REGION 1

Regional Director
 U.S. Fish and Wildlife Service
 Lloyd Five Hundred Building, Suite 1692
 500 N.E. Multnomah Street
 Portland, Oregon 97232

REGION 2

Regional Director
 U.S. Fish and Wildlife Service
 P.O. Box 1306
 Albuquerque, New Mexico 87103

REGION 3

Regional Director
 U.S. Fish and Wildlife Service
 Federal Building, Fort Snelling
 Twin Cities, Minnesota 55111

REGION 4

Regional Director
 U.S. Fish and Wildlife Service
 Richard B. Russell Building
 75 Spring Street, S.W.
 Atlanta, Georgia 30303

REGION 5

Regional Director
 U.S. Fish and Wildlife Service
 One Gateway Center
 Newton Corner, Massachusetts 02158

REGION 6

Regional Director
 U.S. Fish and Wildlife Service
 P.O. Box 25486
 Denver Federal Center
 Denver, Colorado 80225

REGION 7

Regional Director
 U.S. Fish and Wildlife Service
 1011 E. Tudor Road
 Anchorage, Alaska 99503



DEPARTMENT OF THE INTERIOR
U.S. FISH AND WILDLIFE SERVICE



As the Nation's principal conservation agency, the Department of the Interior has responsibility for most of our nationally owned public lands and natural resources. This includes fostering the wisest use of our land and water resources, protecting our fish and wildlife, preserving the environmental and cultural values of our national parks and historical places, and providing for the enjoyment of life through outdoor recreation. The Department assesses our energy and mineral resources and works to assure that their development is in the best interests of all our people. The Department also has a major responsibility for American Indian reservation communities and for people who live in island territories under U.S. administration.