

Report 1141-01-80-CR

**Core Training Tasks Concept:  
Reserve Component Maneuver and  
Artillery Battalions**

FINAL REPORT

By:

Irving Heymont  
Joseph E. Muckerman  
Bruce E. Petree

December 1980

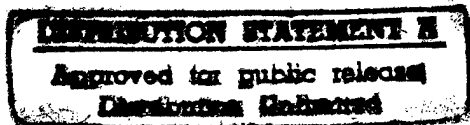

MANAGEMENT TECHNOLOGIES DIVISION

**GENERAL  
RESEARCH**



CORPORATION

A FLOW GENERAL INC. COMPANY

7655 Old Springhouse Road, McLean, Virginia 22102

Prepared For:

Office, Assistant Secretary of Defense  
(Manpower, Reserve Affairs & Logistics)  
Washington, D.C.

Contract MDA 903-80-C-0151

DTC QUALITY INSPECTED 3

19970421 084

The findings in this report are not to be construed as an official Office of Secretary of Defense (OSD) position unless so designated by other authorized documents.

Unclassified

SECURITY CLASSIFICATION OF THIS PAGE (When Data Entered)

REPORT DOCUMENTATION PAGE		READ INSTRUCTIONS BEFORE COMPLETING FORM
1. REPORT NUMBER 1141-01-80-CR	2. GOVT ACCESSION NO.	3. RECIPIENT'S CATALOG NUMBER
4. TITLE (and Subtitle) CORE TRAINING TASKS CONCEPT: RESERVE COMPONENT MANEUVER AND ARTILLERY BATTALIONS		5. TYPE OF REPORT & PERIOD COVERED Final
		6. PERFORMING ORG. REPORT NUMBER
7. AUTHOR(s) Irving Heymont Joseph E. Muckerman Bruce E. Petree		8. CONTRACT OR GRANT NUMBER(s) MDA-903-80-C-0151
9. PERFORMING ORGANIZATION NAME AND ADDRESS General Research Corporation 7655 Old Springhouse Road McLean, Virginia 22102		10. PROGRAM ELEMENT, PROJECT, TASK AREA & WORK UNIT NUMBERS
11. CONTROLLING OFFICE NAME AND ADDRESS Office of Assistant Secretary of Defense (Manpower, Reserve Affairs, and Logistics) Washington, D.C. 20301		12. REPORT DATE December 1980
		13. NUMBER OF PAGES 93
14. MONITORING AGENCY NAME & ADDRESS (if different from Controlling Office)		15. SECURITY CLASS. (of this report) Unclassified
		15a. DECLASSIFICATION/DOWNGRADING SCHEDULE
16. DISTRIBUTION STATEMENT (of this Report) Approved for public release: Distribution unlimited		
17. DISTRIBUTION STATEMENT (of the abstract entered in Block 20, if different from Report)		
18. SUPPLEMENTARY NOTES		
19. KEY WORDS (Continue on reverse side if necessary and identify by block number) Mobilization training Reserve Components Training		
20. ABSTRACT (Continue on reverse side if necessary and identify by block number) A description of development of mission related tasks (core training tasks) in which a unit should demonstrate proficiency to be considered adequately trained for deployment. The application of this concept to Reserve Component tank infantry, mechanized infantry and cannon artillery battalions. The study contains estimates of required postmobilization training times and training support facilities required.		

## INSTRUCTIONS FOR PREPARATION OF REPORT DOCUMENTATION PAGE

**RESPONSIBILITY.** The controlling DoD office will be responsible for completion of the Report Documentation Page, DD Form 1473, in all technical reports prepared by or for DoD organizations.

**CLASSIFICATION.** Since this Report Documentation Page, DD Form 1473, is used in preparing announcements, bibliographies, and data banks, it should be unclassified if possible. If a classification is required, identify the classified items on the page by the appropriate symbol.

### COMPLETION GUIDE

General. Make Blocks 1, 4, 5, 6, 7, 11, 13, 15, and 16 agree with the corresponding information on the report cover. Leave Blocks 2 and 3 blank.

**Block 1.** Report Number. Enter the unique alphanumeric report number shown on the cover.

**Block 2.** Government Accession No. Leave Blank. This space is for use by the Defense Documentation Center.

**Block 3.** Recipient's Catalog Number. Leave blank. This space is for the use of the report recipient to assist in future retrieval of the document.

**Block 4.** Title and Subtitle. Enter the title in all capital letters exactly as it appears on the publication. Titles should be unclassified whenever possible. Write out the English equivalent for Greek letters and mathematical symbols in the title (see "Abstracting Scientific and Technical Reports of Defense-sponsored RDT/E," AD-667 000). If the report has a subtitle, this subtitle should follow the main title, be separated by a comma or semicolon if appropriate, and be initially capitalized. If a publication has a title in a foreign language, translate the title into English and follow the English translation with the title in the original language. Make every effort to simplify the title before publication.

**Block 5.** Type of Report and Period Covered. Indicate here whether report is interim, final, etc., and, if applicable, inclusive dates of period covered, such as the life of a contract covered in a final contractor report.

**Block 6.** Performing Organization Report Number. Only numbers other than the official report number shown in Block 1, such as series numbers for in-house reports or a contractor/grantee number assigned by him, will be placed in this space. If no such numbers are used, leave this space blank.

**Block 7.** Author(s). Include corresponding information from the report cover. Give the name(s) of the author(s) in conventional order (for example, John R. Doe or, if author prefers, J. Robert Doe). In addition, list the affiliation of an author if it differs from that of the performing organization.

**Block 8.** Contract or Grant Number(s). For a contractor or grantee report, enter the complete contract or grant number(s) under which the work reported was accomplished. Leave blank in in-house reports.

**Block 9.** Performing Organization Name and Address. For in-house reports enter the name and address, including office symbol of the performing activity. For contractor or grantee reports enter the name and address of the contractor or grantee who prepared the report and identify the appropriate corporate division, school, laboratory, etc., of the author. List city, state, and ZIP Code.

**Block 10.** Program Element, Project, Task Area, and Work Unit Numbers. Enter here the number code from the applicable Department of Defense form, such as the DD Form 1498, "Research and Technology Work Unit Summary" or the DD Form 1634, "Research and Development Planning Summary," which identifies the program element, project, task area, and work unit or equivalent under which the work was authorized.

**Block 11.** Controlling Office Name and Address. Enter the full, official name and address, including office symbol, of the controlling office. (Equates to funding/sponsoring agency. For definition see DoD Directive 5200.20, "Distribution Statements on Technical Documents.")

**Block 12.** Report Date. Enter here the day, month, and year or month and year as shown on the cover.

**Block 13.** Number of Pages. Enter the total number of pages.

**Block 14.** Monitoring Agency Name and Address (if different from Controlling Office). For use when the controlling or funding office does not directly administer a project, contract, or grant, but delegates the administrative responsibility to another organization.

**Blocks 15 & 15a.** Security Classification of the Report: Declassification/Downgrading Schedule of the Report. Enter in 15 the highest classification of the report. If appropriate, enter in 15a the declassification/downgrading schedule of the report, using the abbreviations for declassification/downgrading schedules listed in paragraph 4-207 of DoD 5200.1-R.

**Block 16.** Distribution Statement of the Report. Insert here the applicable distribution statement of the report from DoD Directive 5200.20, "Distribution Statements on Technical Documents."

**Block 17.** Distribution Statement (of the abstract entered in Block 20, if different from the distribution statement of the report). Insert here the applicable distribution statement of the abstract from DoD Directive 5200.20, "Distribution Statements on Technical Documents."

**Block 18.** Supplementary Notes. Enter information not included elsewhere but useful, such as: Prepared in cooperation with . . . Translation of (or by) . . . Presented at conference of . . . To be published in . . .

**Block 19.** Key Words. Select terms or short phrases that identify the principal subjects covered in the report, and are sufficiently specific and precise to be used as index entries for cataloging, conforming to standard terminology. The DoD "Thesaurus of Engineering and Scientific Terms" (TEST), AD-672 000, can be helpful.

**Block 20.** Abstract. The abstract should be a brief (not to exceed 200 words) factual summary of the most significant information contained in the report. If possible, the abstract of a classified report should be unclassified and the abstract to an unclassified report should consist of publicly-releasable information. If the report contains a significant bibliography or literature survey, mention it here. For information on preparing abstracts see "Abstracting Scientific and Technical Reports of Defense-Sponsored RDT&E," AD-667 000.

## CONTENTS

<u>SECTION</u>		<u>PAGE</u>
1	SUMMARY	1-1
	Introduction	1-1
	Training Strategy for RC Units	1-1
	Application	1-2
	Validation	1-4
	Recommendations	1-4
2	PURPOSE AND METHOD	2-1
	Purpose	2-1
	Method	2-1
	Background	2-1
	Expected Combat Environment	2-2
	Training	2-3
	Review	2-6
	Background Information	2-6
	Historical Experience	2-6
3	TANK BATTALION	3-1
	Core Training Tasks	3-1
	Factors Influencing Accomplishment of Core Tasks	3-3
	Accomplishment of Core Tasks	3-5
	Peacetime Accomplishment	3-6
	Postmobilization Accomplishment	3-8
	Historical Experience--Army Training Program	3-10
	Postmobilization Training Facilities Requirements	3-13
4	MECHANIZED INFANTRY BATTALION	4-1
	General Employment	4-1
	Core Training Tasks	4-1
	Factors Influencing Accomplishment of Core Tasks	4-3
	Accomplishment of Core Tasks	4-5

CONTENTS (Cont.)

<u>SECTION</u>	<hr/>	<u>PAGE</u>
	Peacetime Accomplishment	4-6
	Postmobilization Accomplishment	4-8
	Historical Experience	4-10
	Postmobilization Training Facilities Requirements	4-14
5	INFANTRY BATTALION	5-1
	Applicability	5-1
	General Employment	5-1
	Core Training Tasks	5-1
	Factors Influencing Accomplishment of Core Tasks	5-4
	Accomplishment of Core Tasks	5-5
	Peacetime Accomplishment	5-6
	Postmobilization Accomplishment	5-7
	Historical Experience	5-10
	Postmobilization Training Facilities Requirements	5-13
6	CANNON ARTILLERY	6-1
	The Field Artillery System	6-1
	Core Tasks	6-1
	Factors Influencing Accomplishment of Core Tasks	6-2
	Accomplishment of Core Training Tasks	6-6
	Peacetime Accomplishment	6-7
	Deployability	6-7
	Historical Experience	6-9
 <u>APPENDIX</u>		
A	ORGANIZATION DIAGRAMS	A-1
B	TANK GUNNERY TABLES	B-1
C	SUGGESTED COMMENT FORM	C-1

TABLES

<u>NO.</u>	<hr/>	<u>PAGE</u>
1.1	Postmobilization Training Time	1-3
3.1	Core Training Tasks	3-2
3.2	Possible Peacetime Training Program	3-7
3.3	Estimated Postmobilization Training Time	3-9
3.4	ATP Tank Company Basic Unit Training Tasks	3-11
3.5	ATP Tank Battalion Advanced Unit Training Tasks	3-12
4.1	Core Training Tasks	4-2
4.2	Possible Peacetime Training Program	4-7
4.3	Estimated Postmobilization Training Time	4-9
4.4	ATP Infantry Battalion Training Tasks	4-11
4.5	ATP Infantry Battalion Basic Unit Training Tactical Tasks	4-12
4.6	ATP Infantry Battalion Level Training Tasks	4-14
5.1	Core Training Tasks	5-2
5.2	Possible Peacetime Training Program	5-8
5.3	Estimated Postmobilization Training Time	5-11
5.4	Characteristics of Infantry Battalions Mobilized in 1968	5-12
6.1	Core Training Tasks	6-3
6.2	Suggested Peacetime Training Program	6-8
6.3	Field Artillery Cannon Units ATP Basic Unit Training for Selected Sections	6-10

## SECTION 1

### SUMMARY

#### INTRODUCTION

Recent studies<sup>1</sup> have established that:

- Reserve Component (RC) units face a much more difficult training environment than Active Component units (e.g., peacetime training for RC units is limited to about 39 days per year); and as a consequence,
- A common training strategy for Active and Reserve Component units is not feasible.

In view of the above and the current emphasis on the accelerated deployment of many RC units, a training strategy tailored for the specific needs and circumstances of RC units was developed in a GRC study for the Office of the Secretary of Defense.<sup>2</sup> This training strategy is described in Section 2 of this report and is summarized below. The purpose of the study reported herein was to analyze that training strategy.

#### TRAINING STRATEGY FOR RC UNITS

First, a determination is made of the mission-related training tasks in which a unit should demonstrate proficiency (core training tasks) in order to be considered adequately trained for deployment. This determination is based on an analysis of the unit's total mission-tasks and the minimum number of these tasks in which the unit must

---

<sup>1</sup>Examples of such studies are:

Mobilization Readiness Selected Priority Reserve Component Units, March 1979, and Part 2, February 1980, General Research Corporation.

Combat and Tactical Vehicle Maintenance in the Army, Logistics Management Institute, Washington, D.C., June 1979.

Efficiency of Reserve and Guard Training Has Improved Since 1974, But More Can Be Done, July 1979, The Comptroller General of the United States, Washington, D.C.

<sup>2</sup>Review of the Guard and Reserve (ROGAR II), Office, Secretary of Defense (MRA&L), 1978.

be proficient in order to contribute to success and to survive in the expected combat environment.

Next, an analysis is made to determine which core training tasks can be accomplished in peacetime and which other core training tasks, if any, must be accomplished after mobilization. This step requires detailed consideration of existing realities such as manning levels, personnel turbulence, and adequacy and accessibility of training facilities and resources.

#### APPLICATION

Sections 3 through 6 describe the application of this training strategy to RC tank, mechanized infantry, light infantry, and artillery battalions.

The development of core tasks for these battalions was based on analyses of their organization, equipment, employment doctrine, and the battle conditions expected in the early part of a general war in Central Europe.

The identification of core training tasks that can be accomplished in peacetime was governed by the following considerations and assumptions:

- Only training tasks that can be accomplished over a 3-year period by a well-managed battalion are included.
- The collective training of the battalion is focused on the core training tasks.
- There are no other mandatory collective training tasks prescribed except possibly some that can be executed concurrently with the core training tasks.
- The battalion has at least 75% or more of its wartime authorized strength.

The estimates of required postmobilization training time, as listed in Table 1.1, were based on (1) historical experience and (2) professional judgment.

---

TABLE 1.1  
POSTMOBILIZATION TRAINING TIME<sup>1</sup>

<u>Type Unit</u>	<u>Estimated Postmobilization Training Time (days)</u>
Tank battalion	49
Mechanized infantry	38
Light infantry battalion	35
Cannon artillery battalion	0

<sup>1</sup>Does not include any time required for administrative processing fill with personnel and equipment, or delays in access to required training facilities such as ranges and areas. Such time may not be completely additive to training time.

---

The core training task concept and the resultant estimates of required postmobilization training provide the following:

- An explicit basis for determining required training facilities and areas at mobilization stations.
- An improved basis for mobilization stationing of RC units.
- An improved basis for mobilization and deployment planning; i.e., can RC units meet the deployment schedule specified in the Time Phased Force Deployment Lists (TPFDL)?
- Guidance for RC commanders on priority of training tasks in the development of training programs.
- A factor for consideration in assessing equipment required for peacetime training.

## VALIDATION

The core training tasks and estimates developed in this study were informally reviewed with commanders and staff officers in two USAR separate combat brigades and with informed training specialists at Service Schools, HQ TRADOC, Army Readiness Regions, and Readiness Groups. Permission to review the draft study with additional USAR and ARNG commanders and staff officers was denied by HQDA.

With very few exceptions, the core training concept was considered to be both desirable and necessary. There were some differences of opinion on which training tasks were truly core tasks and on whether some identified for peacetime accomplishment could in fact be accomplished before mobilization. These differences were minor and were primarily concerned with certain types of artillery fire and training tasks for scout platoons.

There were also minor differences on the estimates of the time required for accomplishing some of the core training tasks identified for postmobilization training. These differences were only a matter of a few days for any given core training task.

There was a consensus that the specific applications of the core concept should be widely reviewed with extensive participation by RC commanders. Such a review, it was claimed, would assist not only in gaining acceptance of the concept by the commanders concerned but would also assure a more realistic product.

## RECOMMENDATIONS

- The applications of the core training concept contained in this study should be reviewed by an appropriate sample of RC battalion, brigade, and division commanders. (This review can be accomplished by mail. See Appendix A for suggested comment forms for such a review.)

- TRADOC (appropriate Army Service Schools) should refine and revise, as necessary, the core training concept applications contained in this study, taking into consideration the results of the review described above.
- FORSCOM should test the refined application of the core training concept.
- The deployment schedules, mobilization stationing plans, and peacetime equipment levels for RC units should be reviewed in light of the applications of the core training concept contained in this study.

SECTION 2  
PURPOSE AND METHOD

PURPOSE

The purpose of the study was to analyze a proposed training strategy for US Army Reserve Component units. This strategy involves a backward planning process and is based on the premise that the training environments of the Reserve and Active Components differ so markedly that common training objectives are neither feasible nor desirable. The backward planning process and its underlying rationale are described subsequently under "Background."

METHOD

The analysis is built around the following determinations and estimates for Reserve Component tank, mechanized infantry, infantry, and cannon artillery units:

- The minimum (core) training tasks in which the battalions should be proficient to warrant commitment in combat.
- The core training tasks that the battalions can be expected to accomplish in peacetime.
- Postmobilization training required, if any, to achieve proficiency in those tasks which are not accomplished in peacetime.

BACKGROUND

The training strategy for Reserve Components being analyzed was developed in a recent study<sup>1</sup> prepared by GRC for the Office of the Secretary of Defense. The backward planning process involved in the training strategy is described below.

Step 1: Determine the minimum mission-related tasks in which a unit must demonstrate proficiency in order to be deployable. Attainment of

---

<sup>1</sup>Review of the Guard and Reserve (ROGAR II), op. cit.

this level of proficiency would provide a reasonable assurance that the unit could make a viable contribution to winning the land battle. This determination is based on an analysis of the unit's total mission versus the anticipated urgent need for additional combat units in the early stages of a major war.

Step 2: Determine which of the specified training missions can reasonably be expected to be accomplished in peacetime. Consideration has to be given to realities such as existing manning levels, personnel turbulence, adequacy of Inactive Duty Training (IDT) facilities, the discontinuous nature of IDT, and the availability of equipment and training aids.

Step 3: Identify realistic and meaningful peacetime training goals that are related to deployment requirements. Using these goals as a basis, develop credible estimates of the postmobilization training time needed to make up the difference between the proficiency level attainable in peacetime and deployment training readiness requirements.

Step 4: Establish higher levels of training proficiency together with associated postmobilization training times to be used in the event that there is sufficient time between M-day and the required delivery day (RDD).

#### EXPECTED COMBAT ENVIRONMENT

The determination of training objectives is guided by the assumption that the RC units studied are to be deployed to Central Europe in a conflict involving NATO and the Warsaw Pact countries.

Although the number of scenarios for a Central Europe conflict is almost limitless, there is a consensus that such a conflict would have the following general characteristics:

- The Pact will employ a modern form of blitzkrieg tactics based on armored and mechanized forces to break through and strike deep into the NATO defenses.
- Initial NATO operations will be primarily defensive.
- Casualty rates and requirements for unit and individual replacements will be high.

Some of these battlefield characteristics prevailed in the Korean War--surprise attack with friendly forces initially outnumbered, outgunned, and forced to go on the defensive. Consequently, the selection of core training tasks is influenced by the anticipated urgent requirement for combat reinforcements and replacements.

## TRAINING

### Core Training Tasks

The examination of training is centered on the capability of RC units to attain proficiency in designated core training tasks. For the purpose of this study, core training tasks are defined as the minimum mission-related tasks in which a unit must demonstrate proficiency in order to qualify for employment in combat. As such, these tasks do not necessarily add up to the total mission for which a particular unit was designed. Rather, core training tasks are useful for guiding the training of units with limited training opportunities and establishing readiness criteria for such units.

### Selection of Core Tasks

The method used to identify core training tasks followed these steps:

1. Analysis of all training tasks to identify core training tasks.
2. Determination of which training tasks can be reasonably expected to be accomplished before mobilization.
3. Estimate of postmobilization training time required for the balance, if any.

4. Overall assessment and recommendations for increasing the deployability of the types of units under study.

In the selection of core tasks, the internal operations that are common in varying degrees to all deployable Army units were not considered. These operations are:

- Command and control
- Administration and logistics
- Administrative movement
- Individual and unit survival techniques (NBC environment)

Training in these operations starts during a soldier's initial training and continues through collective training at all levels. Much of this training should be and is integrated with mission training. For example, training in communications and battlefield resupply is an essential and integral part of all tactical exercises. Therefore, tasks common to the internal operations of all combat units are not listed as mission-specific core tasks.

The determination of core tasks for each type of unit was based on analyses of its organization, equipment, employment doctrine, and the expected battle conditions in the first phase of a war in Central Europe. To some degree, this analysis has already been accomplished in the applicable Army Training and Evaluation Program (ARTEP). Therefore, in this study, the ARTEP training tasks were specifically selected in consideration of anticipated operational requirements and the special training circumstances described below.

#### Core Training Tasks--Peacetime Accomplishment

The authorized time in peacetime for the training of RC units is limited to the equivalent of about 39 days, divided between IDT and an annual active duty period of about 15 consecutive days known as "annual training (AT)." IDT comprises the equivalent of 24 days, usually divided into monthly training periods of 2 days each. One factor considered in

the selection of the core training tasks to be accomplished in peacetime was the general limitation of IDT each year to the equivalent of about 16 days for training. The equivalent of about 8 days' IDT each year is required for preparation for AT, recovery from AT, administration (to include advance preparation for mobilization), and other activities. Also, during AT, only about 10 days are actually available for training.

Other factors used in the selection process included:

- Time required for individual MOS training and retraining of prior service recruits.
- Adequacy and availability of equipment, training facilities, and other training support such as ammunition, POL, etc., for both IDT and AT.
- Availability of new or enhanced training methods to increase the number of core training tasks that could be accomplished in peacetime.
- Personnel situation to include turbulence.

#### Postmobilization Training Time

The estimates of required postmobilization training time, if any, were based on historical and current experience and professional judgment. The use of historical experience data was tempered by consideration of subsequent changes in equipment and organization. It was also assumed that scheduled training in a mobilization situation would be based on a 48-hour week.<sup>1</sup>

The estimates of postmobilization training contained in this report are based solely on training time. Therefore, they do not represent the totality of the time required to complete training. Time will also be required for many activities, such as receipt and integration of fillers,

---

<sup>1</sup> A scheduled 48-hour training week normally results in a work week of over 80 hours because of the time required for maintenance, training tests, movement to and from training areas, and other tasks.

individual skill training, and administrative processing; and there may be delays in gaining access to ranges and training areas. This study does not estimate the time for such activities or delays which may not necessarily be completely additive to training time.

#### REVIEW

The training objectives and estimates developed for each type of unit under study were informally reviewed with faculty members of the Infantry, Armor, and Artillery Schools; personnel of HQ TRADOC, Readiness Regions and Groups; and commanders and staff officers of two USAR brigades. Their views were carefully considered in arriving at the various estimates contained in the study. Permission for further informal review of the study by additional USAR and ARNG commanders and staff officers was denied by HQDA.

#### BACKGROUND INFORMATION

Organization diagrams of the units studied are in Appendix A.

#### HISTORICAL EXPERIENCE

Where pertinent, the study draws on historical experiences such as the Army Training Programs (ATPs) which preceded the current ARTEPs and the partial mobilization of 1968 resulting from the Pueblo Crisis. The time stated in the ATPs for attaining proficiency in a specific training task represents the Army experience during the World War II mobilization as modified by subsequent changes in mission and equipment. The experiences of the mobilizations for World War II, the Korean War, and the Berlin Crisis on time for completion of collective training were not considered because they had certain common characteristics that are no longer applicable, principally:

- Many non-prior service members of Reserve Component units lacked active duty basic and advanced individual training.
- Mobilized units during World War II and the Korean War were heavily levied for individual replacements before the completion of unit training.

SECTION 3  
TANK BATTALION

CORE TRAINING TASKS

The core training tasks selected are listed in Table 3.1 together with the references describing them in detail. The selection was based on analysis of the battalion TOE; ARTEP 71-2, June 1977; and Field Manuals 17-12, Tank Gunnery; 71-1, The Tank and Mechanized Infantry Combat Team; 71-2, The Tank and Mechanized Infantry Battalion Task Force; and 71-100, Armored and Mechanized Infantry Operations. Brief descriptions of the gunnery tables cited in Table 3.1 are in Appendix C.

ARTEP 71-2, FM 71-2, and FM 17-12 together describe the totality of the training tasks for a fully trained tank battalion. The discussion below gives the rationale for omission of certain training tasks as core tasks. Many of the omitted tasks are, in fact, preliminary training exercises necessary to achieving proficiency in the core tasks.

Exploitation. Eliminated as a battalion task force training task; includes most of the tactical elements covered in "movement to contact and the hasty attack." Further, it is reasonable to expect that, by the time an exploitation situation arises, the battalion task force will have achieved a high degree of tactical ability.

Disengage (under pressure). Eliminated as a battalion task force and company team task; duplicates most of the tactical elements in the training task delay (high risk).

Prepare strong point. Eliminated as a company team and platoon task; duplicates most of the tactical elements in the training task defense.

Deliberate attack (live fire). Eliminated as a company team task; has marginal training value because the required safety considerations usually restrict use of the terrain and limit fire and maneuver.

TABLE 3.1  
CORE TRAINING TASKS

Subelement/Task

<u>Tank Crew</u>	<u>Reference</u>
Tank Crew Gunnery Skills Test	FM 17-12, para 17-5
Tank Gunnery Tables I-VIIC	FM 17-12, paras 20-6 thru 20-9
Tank Gunnery Table VIIIA,B	FM 17-12, para 20-9
 <u>Tank Platoon</u>	
Movement to Contact	ARTEP 71-2, App 21 to Chapter 8
Defense	ARTEP 71-2, App 23 to Chapter 8
Defense Against Aircraft	FM 17-12, para 16-1 thru 16-6
	ARTEP 71-2, App 25 to Chapter 8
Defense of a Built-Up Area	ARTEP 71-2, App 24 to Chapter 8
Tank Gunnery Table IXC	FM 17-12, para 20-10
Tank Gunnery Table IXA, B	FM 17-12, para 20-10
 <u>Heavy Mortar Platoon</u>	
Indirect Fire	ARTEP 71-2, App 41 to Chapter 8
 <u>Scout Platoon</u>	
Zone Reconnaissance and Hasty Attack	ARTEP 71-2, App 39 to Chapter 8
Screen (night)	ARTEP 71-2, App 37 to Chapter 8
 <u>Redeye Section</u>	
	ARTEP 71-2, App 43 to Chapter 8
 <u>Ground Surveillance Section</u>	
	ARTEP 71-2, App 44 to Chapter 8
 <u>AVLB Section</u>	
	ARTEP 71-2, App 25 to Chapter 6
 <u>Company Team</u>	
Movement to Contact	ARTEP 71-2, App 1 to Chapter 8
Hasty Attack	ARTEP 71-2, App 2 to Chapter 8
Deliberate Attack	ARTEP 71-2, App 3 to Chapter 8
Defense	ARTEP 71-2, App 6 to Chapter 8
Delay High Risk	ARTEP 71-2, App 7 to Chapter 8
Night Attack	ARTEP 71-2, App 5 to Chapter 8
Defense of a Built-Up Area	ARTEP 71-2, App 19 to Chapter 8
 <u>Battalion Task Force</u>	
Movement to Contact	ARTEP 71-2, App 10 to Chapter 8
Hasty Attack	ARTEP 71-2, App 11 to Chapter 8
Deliberate Attack	ARTEP 71-2, App 12 to Chapter 8
Defense	ARTEP 71-2, App 15 to Chapter 8
Delay High Risk	ARTEP 71-2, App 16 to Chapter 8
Night Attack	ARTEP 71-2, App 14 to Chapter 8
Defense of a Built-Up Area	ARTEP 71-2, App 9 to Chapter 8

Tank platoon: hasty attack; is included in Table IX tank gunnery training.

Scout platoon; route and area reconnaissance and scout squad: firing proficiency; duplicate most of the tactical elements in the training task zone reconnaissance and hasty attack.

#### FACTORS INFLUENCING ACCOMPLISHMENT OF CORE TASKS<sup>1</sup>

##### Doctrine

The combat employment of the tank battalion is based on the use of combined arms. Tank and infantry battalions (mechanized or light) are organized as battalion task forces containing a mixture of tank and infantry companies and other elements. Within the battalion task force the companies are organized as company teams containing a mixture of tank and infantry platoons and other elements. Within the company team, elements of the tank platoons are rarely further attached to other units. The precise mix of tank and infantry platoons and companies within company teams and battalion task forces is dependent upon the specific tactical situation. In sum, tank battalions and tank companies are not normally employed in combat solely as tank units. Consequently, training of tank battalions at the company and battalion levels requires that infantry units be available to form company teams and battalion task forces.

##### Stationing

The component companies of RC tank battalions, with a few minor exceptions, are stationed in separate towns that are distant from each other. In some cases, companies are further divided between two towns. Most RC tank battalions seldom assemble for IDT, but virtually all do so for AT.

---

<sup>1</sup>A more complete description of the nondoctrinal factors influencing the peacetime training of RC tank battalions is contained in Evaluation of Training Status (U), CR-221, September 1978 (CONFIDENTIAL).

None of the maneuver companies of the RC tank battalions is collocated (same town) with RC maneuver infantry companies. Time-distance factors, scheduling problems, and the need for individual training currently make combined arms training during IDT impractical.

#### Personnel Turbulence

RC tank battalions, like other RC units, have a significant degree of turbulence resulting from many factors including many prior service personnel who enlist for only 1 year. Most prior service personnel enlisting in tank battalions have not previously served in such units. Precise data are not available, but several RC tank battalion companies and Readiness Region and Group personnel have estimated that at least 25% of the members of a tank battalion at any given time are not with the unit 1 year later. These estimates are in accord with turbulence data in the total Army Selected Reserve. High turbulence rates result in repetition of lower level training and inhibit development of teamwork within squads, crews, sections, and platoons.

#### Personnel Strength

RC tank battalions are authorized either full structure strength or AL02, which is about 10% less.<sup>1</sup> Virtually all of the RC tank battalions are now understrength.<sup>2</sup> The average is 81% and ranges from 104% to 51%.<sup>3</sup> Five battalions are below 70% of wartime authorized strength. Most of the personnel shortages are concentrated in the tank crews because of administrative and maintenance workloads. This understrength inhibits effective training of crews and higher subelements and creates additional postmobilization training requirements.

There are various programs under way designed to increase the strength of RC units but the success of these programs is not yet determined.

---

<sup>1</sup>Actually 100% for officers and 90% for enlisted men.

<sup>2</sup>There are 45 RC tank battalions.

<sup>3</sup>Based on October 1979 Unit Status reports.

### Training Facilities

The training facilities available to most RC tank battalions for IDT vary widely in quality and accessibility. Usually the nearest available field training site requires several hours of travel. Many companies lack adequate facilities at their home stations and many do not have more than one tank at the home station (local restrictions on track laying vehicles). The negative impact of lack of adequate facilities on the effectiveness of IDT training is obvious, particularly when it prevents hands-on training with major mission equipment items.

### ACCOMPLISHMENT OF CORE TASKS

The doctrine for employment of tank units and the stationing situation of the RC tank battalions dictate that all core tasks involving field training as company teams and battalion task forces can, in fact, be accomplished only after mobilization. Conduct of combined arms training in peacetime during AT at team and task force levels is hardly feasible because of scheduling problems and the time required to accomplish the crew and platoon level core tasks. Some training in company team and battalion task force core tasks can be conducted in peacetime by use of map exercises, command post exercises, and other methods not involving use of subordinate units on the ground.

Upon mobilization it can be expected that there will be some personnel losses and that the battalions will be brought up to at least AL02 (90%) strength before deployment. Consequently, there will be changes within tank crews and platoons and a resulting need to fire the tank crew qualification course (Table VIII) and the platoon battle run course (Table IX).

Even if there were no personnel turbulence, it would be essential to fire these courses after mobilization. Both cannot be fired more than once a year in peacetime because of ammunition limitations.<sup>1</sup> It would be imprudent to deploy a tank battalion for combat with crews and platoons that have not recently fired these courses.

---

<sup>1</sup>Frequently time and facilities are also limitations.

In summary, the core tasks listed below are postmobilization tasks because of the characteristics of the RC environment.

- All battalion task force and company team tasks involving field exercises with troops
- Tank crew gunnery, Table VIIIA, B
- Tank platoon gunner, Table IXA, B

#### PEACETIME ACCOMPLISHMENT

The core tasks, other than those listed immediately above for accomplishment after mobilization, are capable of being accomplished in peacetime by a well-managed tank battalion over a 3-year period. This estimate is based on the following assumptions:

- The battalion is given specific training directives along the lines formerly contained in FORSCOM Regulation 350-2 for tank battalions.
- There are no other mandatory training tasks prescribed except possibly some that can be executed concurrently with the core training tasks.
- The battalion has at least 70% or more of its wartime authorized strength.

The nonfiring tank platoon core tasks can be accomplished in a combination of IDT and AT. Much of the preparatory training in these core tasks can be accomplished in IDT without the use of tanks. AT can then be devoted to completing the training with the use of all applicable TOE equipment.

One possible 3-year schedule is given in Table 3.2. This schedule is based on achieving and maintaining proficiency in core tasks, without regard to a specified number of training assemblies for each core task. Variances between units in the levels of gunnery proficiency that can be attained during IDT are to be expected because of differences in the availability of ranges and support.

TABLE 3.2

## POSSIBLE PEACETIME TRAINING PROGRAM

<u>Core Task</u>	<u>1st Year</u>	<u>2d Year</u>	<u>3d Year</u>
<u>Tank Crew</u>			
Tank Crew Gunnery Skills Test	x	x	x
Gunnery Tables I-III <sup>1</sup>	x	x	x
Gunnery Tables IV-VI <sup>2</sup>	x	x	x
Gunnery Table VIIC <sup>3</sup>		x	x
<u>Tank Platoon</u>			
Gunnery Table IXC <sup>3</sup>		x	x
Movement to Contact		x	x
Defense Against Aircraft		x	x
Defense of a Built-Up Area		x	x
<u>Heavy Mortar Platoon</u>			
Indirect Fire	x	x	x
<u>Scout Platoon</u>			
Zone Reconnaissance and Hasty Attack	x	x	x
Screen (night)		x	x
<u>Redeye Section</u>			
Air Defense Support	x	x	x
<u>Ground Surveillance Section</u>			
Ground Surveillance Support	x	x	x
<u>AVLB Section</u>			
Support of Tactical Operations	x	x	x

<sup>1</sup>Subcaliber firing.

<sup>2</sup>Table VI is the first table permitting the crew to fire the main gun.

<sup>3</sup>Includes firing Table VP.

Table IXC probably can be accomplished in peacetime during AT if time and suitable ranges are available. The accomplishment of this core training task in peacetime is a difficult goal but not an impossible one for units with adequate personnel strength and access to appropriate ranges during IDT for firing the tables that precede Table IXC.

Although not shown in Table 3.2, training in company team and battalion task force core tasks can also be conducted but by means of map exercises, command post exercises, and other means not involving field exercises with troops.

#### POSTMOBILIZATION ACCOMPLISHMENT

It is estimated that at least 49 training days will be required for postmobilization training of an RC tank battalion. This estimate is based on the assumptions listed below:

- Time to achieve proficiency in the core tasks will, on the average, be as given in Table 3.3.
- Infantry units will be available to form company teams and battalion task forces as required.<sup>1</sup>
- Appropriate tank gunnery ranges will be available as required.
- The tank battalion is at 80% or more of wartime authorized strength in personnel and equipment.
- The battalion will not be reequipped with different types of tanks or other major systems.

Table 3.3 shows the estimated training time for each core task to be accomplished after mobilization. The estimates provide a basis for estimating the total postmobilization time required before deployment. Some of the core tasks may require more time and some less time. However, it is considered that overall the total time shown will be the minimum required by most RC tank battalions under the assumptions listed above.

---

<sup>1</sup>This assumption is made in order to estimate minimum postmobilization training time. Delays will occur depending on range facilities and density of units at a given mobilization station.

TABLE 3.3

ESTIMATED POSTMOBILIZATION TRAINING TIME  
(days)

<u>Core Task</u>	<u>Estimated Time</u>
<u>Gunnery</u>	
Tank Gunnery Table VIIIA, B	21
Tank Gunnery Table IXA, B	7
<u>Company Team</u> <sup>1</sup>	
Movement to Contact	( 2
Hasty Attack	( 3
Deliberate Attack	3
Defense	3
Delay High Risk	2
Night Attack	2
Defense of a Built-Up Area	(Map Exercise) <sup>2</sup>
<u>Battalion Task Force</u> <sup>1</sup>	
Movement to Contact	( 1
Hasty Attack	( 2
Deliberate Attack	2
Defense	2
Delay High Risk	2
Night Attack	2
Defense of a Built-Up Area	(Map Exercise) <sup>2</sup>
Total	49

<sup>1</sup>Training in some of these core training tasks can be conducted in peacetime using map exercises and other techniques not involving troop units.

<sup>2</sup>Concurrent with other training.

The listing in Table 3.3 does not indicate a prescribed sequence for performance. For example, it is possible that one tank company of the battalion might be training to qualify on Tables VIIIA, B, while simultaneously another tank company is firing Tables IXA, B, and the third tank company is training in company team core tasks. Similarly, elements of the battalion task force headquarters and other units of the task force may be participating in company team exercises and conducting map and command post exercises and other exercises not involving troop units.

#### HISTORICAL EXPERIENCE--ARMY TRAINING PROGRAM

The Army Training Programs for the collective training of tank battalions provided for a total of about 13 weeks of training divided as follows:

- Basic unit training (through company level):<sup>1</sup> 10 weeks
- Advanced unit training (through battalion level):<sup>2</sup> 3 weeks

The training tasks and allocations of time for basic unit training are shown in Table 3.4. The time allocation is based on a nominal 44-hour week.

The training tasks and allocations of time for advanced unit training are shown in Table 3.5. The ATP recommends cross-attachment or reinforcement with mechanized infantry, but does not require it. The participation of artillery liaison and USAF personnel is also recommended.

---

<sup>1</sup>Army Training Program, 17-37, Tank Company, 9 August 1966.

<sup>2</sup>Army Training Program, 17-35, Armor Battalions, 15 January 1974.

TABLE 3.4  
 ATP TANK COMPANY  
 BASIC UNIT TRAINING TASKS

Training Tasks	Nominal Hours
<u>General Subjects</u>	<u>184</u>
Character guidance and command information	(13)
Physical conditioning	(4)
First aid	(2)
CBR operations	(12)
Intelligence training	(4)
Inspections, drill, and ceremonies	(14)
Map reading	(8)
Land mine warfare	(10)
Maintenance	(76)
Commander's time	(35)
<u>Tank Training</u>	<u>256</u>
Tank crew gunnery qualification	(56)
Underwater fording	(28)
Tank crew cross-country exercise	(4)
Tank crew firing positions	(4)
Tank platoon battle drill	(4)
Tank platoon - attack	(16)
Tank platoon - retrograde	(10)
Tank-infantry operations	(12)
Tank company battle drill	(4)
Tank company - attack	(12)
Tank company - defense	(8)

TABLE 3.5  
ATP TANK BATTALION ADVANCED UNIT TRAINING TASKS

Training Task	Nominal Hours	Additional Hours
<u>General Subjects</u>	57	
Maintenance	(22)	
Rail loading	(6)	
Air loading	(4)	
Commander's time	(10)	
Other	(15)	
 <u>Offensive Operations</u>	 21	 6
Deliberate attack		
Exploitation		
 <u>Defensive Operations</u>	 10	 6
Mobile defense (including forward defense, reserve mission, counter- attacks)		
 <u>Retrograde Operations</u>	 8	 4
Delaying action		
Withdrawal		
 <u>Training Test</u>	 24	 48
Offensive operations		
Defensive operations		
Retrograde operations		

<sup>1</sup>No breakout of hours by specific tasks stated.

<sup>2</sup>Night training in addition to the nominal hours.

## POSTMOBILIZATION TRAINING FACILITIES REQUIREMENTS

- Ranges for firing tank gunnery Tables VIIIA, B, and IXA, B
- Ranges for refresher training and evaluation of proficiency of the following:

### Anti-Tank Support

- TOW
- DRAGON
- LAW
- 90mm and 106mm recoilless rifles

### Indirect Fire Support

- 81mm mortar
- 4.2-inch mortar

### Air Defense Support

- REDEYE/STINGER

- Maneuver areas for at least one tank battalion/task force for the training tasks listed below to include artillery, helicopter gunship, and tactical air support.

- Movement to contact
- Hasty attack
- Deliberate attack
- Defense
- Delay high risk
- Night attack
- Defense of urban area

## SECTION 4

### MECHANIZED INFANTRY BATTALION

#### GENERAL EMPLOYMENT

The capabilities of mechanized infantry are designed to complement armor. Consequently, units of the battalion normally operate as part of a battalion task force which is made up of tank and mechanized infantry companies grouped and commanded by the headquarters of either a tank or mechanized infantry battalion. The battalion task force in turn receives support from available field and air defense artillery, attack helicopters, and USAF tactical fighter bombers. The battalion task force, then, is a combined arms team.

#### CORE TRAINING TASKS

The core training tasks are listed in Table 4.1 together with the references describing them in detail. The selection was based on analysis of the battalion TOE; ARTEP 71-2, June 1977; and Field Manuals 7-7, The Mechanized Infantry Platoon and Squad; 71-1, The Tank and Mechanized Infantry Company Team; 71-2, The Tank and Mechanized Infantry Battalion Task Force; and 71-100, Armored and Mechanized Infantry Operations.

ARTEP 71-2 and FM 71-2 together describe the totality of the training tasks for a fully trained mechanized infantry battalion. The discussion below gives the rationale for omission of certain training tasks as core tasks. Many of the omitted tasks are, in fact, preliminary training exercises necessary to achieving proficiency in the core tasks.

Exploitation: Eliminated as a battalion task force training task. This task includes most of the tactical elements covered in "movement to contact and the hasty attack."

Defense of a built-up area: Eliminated as a task at the squad and platoon levels but retained at the company team and task force levels. The squad and platoon training tasks can be incorporated into training at the company team and task force levels.

TABLE 4.1  
CORE TRAINING TASKS

SUBELEMENT/TASK	<u>Reference (ARTEP 71-2, Chapter 8)</u>
<u>Mechanized Infantry Rifle Squad/Crew</u>	
Movement to Contact	App 30
Reconnaissance Patrol	App 31
Forced March (Live Fire)	App 32
Antiarmor Ambush	App 33
M113 Crew Firing Proficiency	App 35
Antitank Fire Support	Apps 49 and 50 <sup>1</sup>
<u>Mechanized Infantry Platoon</u>	
Movement to Contact	App 21
Hasty Attack	App 22
Defense	App 23
Defense Against Aircraft (Live Fire)	App 25
<u>Mortar Platoons/Sections</u>	
Indirect Fire Support (Heavy Mortar)	App 41
Indirect Fire Support (81mm Mortar)	App 42
<u>Scout Platoon</u>	
Zone Reconnaissance and Hasty Attack (Live Fire)	App 39
Screen (Night)	App 37
<u>Antitank Platoon/Section/Squad</u>	
Antitank Fire Support <sup>2</sup>	Apps 45 or 46 or 48 <sup>2</sup>
<u>Company Team</u>	
Movement to Contact	App 10
Hasty Attack	App 11
Deliberate Attack	App 12
Defense	App 15
Delay High Risk	App 16
Night Attack	App 14
Defense of a Built-Up Area	App 19
<u>Battalion Task Force</u>	
Movement to Contact	App 1
Hasty Attack	App 2
Deliberate Attack	App 3
Defense	App 6
Delay High Risk	App 7
Night Attack	App 5
Defense of a Built-Up Area	App 9

<sup>1</sup>If equipped with DRAGON system.

<sup>2</sup>Depending on AT weapons issued.

Disengage (under pressure): Eliminated as a battalion task force and company team task. This task duplicates most of the tactical elements in the training task "delay (high risk)."

Prepare strong point: Eliminated as a company team and platoon task. This task duplicates most of the tactical elements in the training task "defense."

Deliberate attack (live fire): Eliminated as platoon and company team tasks. This task has marginal training value because safety provisions restrict use of the terrain and limit fire and maneuver.

Deliberate defense (live fire): Eliminated as a platoon task for the reasons cited above.

Scout platoon: Route and area reconnaissance and scout squad firing proficiency: Eliminated because these tasks duplicate most of the tactical elements in the training task "zone reconnaissance and hasty attack."

#### FACTORS INFLUENCING ACCOMPLISHMENT OF CORE TASKS

##### Doctrine

Mechanized infantry normally fights with tanks and, if the situation permits, will fight mounted in armored personnel carriers (APCs) or Infantry Fighting Vehicles (IFVs). When fighting dismounted, it will, whenever possible, be supported by fires from tanks or weapons on board the carriers. Mechanized infantry can change rapidly from fighting mounted to fighting dismounted.

##### Organization for Combat

Tank and mechanized infantry battalions are organized as battalion task forces containing a mixture of tank and infantry companies and other elements. Within the battalion task force the companies are organized as company teams containing a mixture of tank and infantry platoons and other

elements. Within the company team, elements of the tank platoons are rarely further attached to other units. The precise mix of tank and infantry platoons and companies within company teams and battalion task forces is dependent upon the specific tactical situation. Thus, mechanized infantry battalions and companies are not normally employed in combat solely as infantry units.

#### Stationing

The component companies of RC mechanized infantry battalions, with a few exceptions, are stationed in towns distant from one another. In some cases, companies are further divided between two towns. Very few, if any, of the maneuver companies of the RC mechanized infantry battalions are located in towns that also have RC tank companies. Combined arms training during IDT is impractical, as previously discussed in Section 3. Virtually all mechanized infantry battalions assemble for AT but most IDT assemblies are by company.

#### Personnel Turbulence

RC mechanized infantry battalions, like other RC units, have a significant degree of turbulence resulting from many factors. Precise data are not available but it is estimated that at least 25% of the members of an infantry battalion at any given time are not with the unit 1 year later. High turbulence rates result in repetition of low level training and inhibit development of teamwork with squads, sections, and platoons.

#### Personnel Strength

RC mechanized infantry battalions are authorized either full structure strength or AL02 which is about 10% less.<sup>1</sup> Virtually all of the RC mechanized infantry battalions are now understrength. The average strength is 71% and ranges from 37% to 102%. About one-half of all the battalions are below 70% of wartime authorized strength. Most of the personnel shortages are concentrated in the rifle platoons because of

---

<sup>1</sup>Actually, 100% for officers and 90% for enlisted men.

administrative and maintenance workload. This understrength inhibits effective training of squads and platoons and creates additional postmobilization training requirements.

Various programs under way are designed to increase the strength of RC units but the success of these programs is not yet clear. Experience has shown that RC infantry units have more difficulty in recruiting and retention than the other RC combat arms units.

#### Training Facilities

The training facilities available to RC mechanized infantry units are generally the same as those available to RC tank battalions. The facilities vary widely in quality and accessibility. Usually the nearest available field training site requires several hours of travel. Many companies lack adequate facilities at their home station, and many do not have more than one APC at the home station (local restrictions on track laying vehicles). The negative impact of lack of adequate facilities on the effectiveness of IDT training is obvious, particularly when it prevents hands-on training with major mission equipment items.

#### ACCOMPLISHMENT OF CORE TASKS

The doctrine for employment of mechanized infantry units, the stationing situation of the RC mechanized infantry battalions, and time limitations dictate that all core tasks involving field training as company teams and battalion task forces can, in fact, be accomplished only after mobilization. Conduct of combined arms training in peacetime during AT at team and task force levels is hardly feasible for most RC battalions because of scheduling problems and the time required to accomplish the squad/crew and platoon level core tasks. However, some training in company team and battalion task force core tasks can be conducted in peacetime by use of map exercises, command post exercises, and other methods not involving use of subordinate units on the ground.

Upon mobilization it can be expected that there will be some personnel losses and that the battalions will be brought up to about AL02 (90%) strength before deployment. Consequently, there will be changes within squads and platoons and a resulting need to refire the weapon crews.

In summary, all battalion task force and company team tasks involving field exercises with troops are postmobilization tasks because of the characteristics of the RC environment. Additionally, the core training tasks involving firing of weapons should be repeated as postmobilization training tasks because of changes of assignments and influx of personnel.

#### PEACETIME ACCOMPLISHMENT

The core tasks, other than those summarized above for accomplishment after mobilization, are capable of being accomplished in peacetime by a well-managed mechanized infantry battalion over a 3-year period. This estimate is based on the following assumptions:

- The collective training of the battalion is focused on the core training tasks.
- There are no other mandatory collective training tasks prescribed except possibly some that can be executed concurrently with the core training tasks.
- The battalion has at least 70% or more of its wartime authorized strength.

One possible 3-year schedule is given in Table 4.2. This schedule is based on achieving and maintaining proficiency in core tasks and not on devoting a specified number of training assemblies to each core task. In the preparation of this schedule, consideration was given to the time necessary for individual skill training. Variances in the levels of proficiency that can be attained during IDT are to be expected because of differences in the availability of ranges, training areas, and other aspects of training support.

TABLE 4.2  
POSSIBLE PEACETIME TRAINING PROGRAM

	<u>1st Year</u>	<u>2nd Year</u>	<u>3rd Year</u>
<u>Mechanized Infantry Crew/Squad</u>			
Movement to Contact	X	X	
Reconnaissance Patrol	X	X	X
Forced March (Live Fire)	X	X	X
Anti-armor Ambush		X	X
M113 Crew Firing Proficiency	X	X	X
Antitank Fire Support	X	X	X
<u>Antitank Platoon/Section/Squad</u>			
Antitank Fire Support	X	X	X
<u>Mechanized Infantry Platoon</u>			
Movement to Contact	X	X	
Hasty Attack	X	X	X
Defense	X	X	X
Defense Against Aircraft (Live Fire)			X
<u>Mortar Platoons/Sections</u>			
Indirect Fire Support (Heavy Mortar)	X	X	X
Indirect Fire Support (81mm Mortar)	X	X	X
<u>Redeye Section</u>			
Air Defense Support	X	X	X
<u>Scout Platoon</u>			
Zone Reconnaissance and Hasty Attack	X	X	X
Screen (Night)		X	X
<u>Ground Surveillance Section</u>			
General Surveillance Support	X	X	X

Although not shown in Table 4.2, training in company team and battalion task force core tasks would also be conducted but by means of map exercises, command post exercises, and other means not involving field exercises with troops.

#### POSTMOBILIZATION ACCOMPLISHMENT

It is estimated that at least 35 training days will be required for postmobilization training of RC mechanized infantry battalions. This estimate is based on the assumptions listed below:

- Time to achieve proficiency in the core tasks will, on the average, be as given in Table 4.3.
- Tank units will be available to form company teams and battalion task forces as required.
- Appropriate ranges will be available as required.
- The battalion is at 80% or more of wartime authorized strength in personnel and equipment.
- The battalion will not be reequipped with different types of weapons or other major items.

Table 4.3 shows the estimated training time for each core task to be accomplished after mobilization. The estimates provide a basis for estimating the total postmobilization time required before deployment. Some of the core tasks may require more time and some less time. However, it is considered that, overall, the total time shown will be the minimum required by most RC mechanized infantry battalions under the assumptions listed above.

The listing in Table 4.3 does not indicate a prescribed sequence for performance. For example, it is possible that one company of the battalion might be engaged in refresher firing while simultaneously another company is training in company team core tasks. Similarly, elements of the battalion task force headquarters and other units of the task force may be participating in company team exercises and conducting map and post exercises and other exercises not involving troop units.

TABLE 4.3  
ESTIMATED POSTMOBILIZATION TRAINING TIME  
(days)

<u>Core Task</u>	<u>Estimated Time</u>
<u>Refresher Firing</u>	14
<u>Crew/Squad</u>	
Forced March (Live Fire)	
Antitank Fire Support	
<u>Antitank Platoon/Section/Squad</u>	
Antitank Fire Support	
<u>Mortar Platoons/Sections</u>	
Indirect Fire Support	
<u>Redeye Section</u>	
Air Defense Support	
<u>Scout Platoon</u>	
Crew Live Fire Exercise	
<u>Company<sup>1</sup> Training Tasks</u>	
Movement to Contact	2
Hasty Attack	3
Deliberate Attack	1
Night Attack	(Map Exercise) <sup>2</sup>
Attack of an Urban Area	3
Defense	(Map Exercise) <sup>2</sup>
Defense of an Urban Area	1
Night Withdrawal	2
Delay	2
Airmobile Assault	2
<u>Battalion Training Tasks</u>	
Movement to Contact	2
Hasty Attack	2
Deliberate Attack	2
Night Attack	2
Attack of an Urban Area	(Map Exercise) <sup>2</sup>
Defense	(3) <sup>3</sup>
Defense of an Urban Area	(Map Exercise) <sup>2</sup>
Night Withdrawal	(1) <sup>3</sup>
Delay	2
Airmobile Assault	(2) <sup>3</sup>
Total	38

<sup>1</sup>It is assumed that some training in these core tasks was conducted in peacetime using map exercises and other techniques not involving troop units.

<sup>2</sup>Concurrent with other training.

<sup>3</sup>Concurrent with similar company training.

The estimated 38 days for postmobilization training covers training time only. This estimate does not include time for individual skill training that may be necessary, preparations to start training after closing at the mobilization station, delay in receipt of fillers, waiting for range and training area availability, and similar factors. These times may not be completely additive to collective training time.

## HISTORICAL EXPERIENCE

### Army Training Program

The Army Training Programs (ATPs) for infantry companies and battalions covered all types of infantry including airborne and airmobile. Within these ATPs, some differentiation was made between two groups of infantry units. One group consisted of mechanized infantry and infantry units. The other group consisted of airborne, airmobile, and light infantry. The discussion that follows covers only the collective<sup>1</sup> training of mechanized and infantry battalions.

The last ATP<sup>2</sup> for the collective training of infantry battalions provided for a total of about 11 weeks of training divided as follows:

- Basic unit training (through company level) 8 weeks
- Advanced unit training (battalion level) 3 weeks

The training tasks and allocation of time for this period of 11 weeks is shown in Table 4.4. The time allocation is based on a nominal 44-hour week but does not include hours devoted to night training.

The tactical training tasks included in Basic Unit Training are shown in Table 4.5. The number of hours shown are based on the estimated hours in the applicable Army Subject Schedule for instruction in that subject. The Army Training Program reduces the total time without specifying reductions by subject.

---

<sup>1</sup>Training at the squad/team level and higher.

<sup>2</sup>ATP 7-18, "Rifle Company, Infantry, Airborne, Airmobile, and Light Infantry Battalion," 2 April 1968. ATP 7-15, "Infantry, Airborne Infantry, Airmobile Infantry, Light Infantry, and Mechanized Infantry Battalions and Brigades," 8 April 1968.

TABLE 4.4  
ATP INFANTRY BATTALION TRAINING TASKS

Training Task	Estimated Hours
<u>Basic Unit Training</u>	
General subjects (primarily individual training including 48 hours for Commander's time)	185
Squad tactical training	24
Platoon tactical exercises	71
Company tactical exercises	72
Subtotal	(352)
<u>Advanced Unit Training (battalion level)</u>	
General subjects	29
Field exercise #1	36 (minimum)
Field exercise #2	36 (minimum)
Field exercise #3 (training test)	48 (minimum)
Subtotal	(149)
Total	501 (11 weeks)

TABLE 4.5  
ATP INFANTRY BATTALION BASIC UNIT TRAINING TACTICAL TASKS

Training Task	Estimated Hours
<u>Squad</u>	
Attack	7
Night raid	6
Road clearing	4
Defense	9
Outguard	4
Patrolling	10
<u>Platoon</u>	
Day dismounted attack	11
Advance party	4
Defense	10
Night attack	5
Mechanized platoon in the attack	10
Minefields	4
Combat outpost	4
Night relief	4
Attack of a fortified position	4
Retrograde	8
Attack of a built-up area	4
Counter ambush	8
Night patrol	8
Platoon leadership exercise	12
<u>Company</u>	
Advance guard	6
Flank security	6
Day and night attack	30
Day and night defense	20
Day and night withdrawal	10
Night raids	5
Day and night relief	8
Delaying action	7
Combat outpost	7

Table 4.6 shows the tactical tasks included in battalion training of advanced unit training. The ATP does not estimate the time allocation for each battalion level training task. The ATP provided for a brigade field exercise continuing for at least 96 hours. The training tasks to be included in this brigade exercise are:

- Movement to contact
- Delaying action
- Night withdrawal and rearward passage of lines
- Area defense
- Attack
- Consolidation of objective
- Reconnaissance in force
- Advance against enemy delaying actions
- Penetration and exploitation

#### Mobilization Experience<sup>1</sup>

In the 1968 mobilization, only one mechanized infantry battalion (2/133 Inf, Iowa ARNG) was mobilized. The battalion was at 97% of TOE strength when alerted and at 94% when mobilized.

Just prior to mobilization the unit was evaluated as requiring 8 weeks to complete the battalion ATP. On mobilization, the unit was reevaluated as requiring 11 weeks to complete the ATP. After 13 weeks of training, including some minor reorganization, the battalion failed its Army Training Test and required 2 more weeks to successfully complete battalion training.

---

<sup>1</sup>Review and Analysis of Recent Mobilizations and Deployments of US Army Reserve Components, Research Analysis Corporation, RAC-CR-67, October 1972.

TABLE 4.6  
ATP INFANTRY BATTALION LEVEL TRAINING TASKS

Training Task	Estimated Hours
General subjects (including 12 hours for Commander's time)	29
Field Exercise #1	36 (minimum) <sup>1</sup>
Movement to contact	
Advance against a delaying enemy	
Penetration and exploitation	
Defense (while in contact or contact imminent)	
Continuation of the attack	
Field Exercise #2	36 (minimum) <sup>1</sup>
Organization of defense (not in contact)	
Delaying action	
Perimeter defense (while in contact or contact imminent)	
Field Exercise #3	24 (minimum)
Army Training Test	
Total	125 (minimum) (3 weeks)

<sup>1</sup>No breakout given for the listed training tasks.

## POSTMOBILIZATION TRAINING FACILITIES REQUIREMENTS

- Ranges for refresher training and evaluation of proficiency of the following:

### Anti-tank Support

- TOW
- DRAGON
- LAW
- 90mm and 106mm recoilless rifles

### Indirect Fire Support

- 81mm mortar
- 4.2-inch mortar

### Air Defense Support

- REDEYE/STINGER

### Reconnaissance and Hasty Attack

(live fire)

- Maneuver area for at least one tank-infantry task force for the training tasks listed below to include artillery, helicopter gunship, and tactical air support.

- Movement to contact
- Hasty attack
- Deliberate attack
- Defense
- Delay high risk
- Night attack
- Defense of an urban area

- Urban area mockup

- Platoon attack and defense<sup>1</sup>

---

<sup>1</sup>For refresher training as required.

## SECTION 5

### INFANTRY BATTALION

#### APPLICABILITY

This section applies only to the infantry battalions (TOE 7-15H) of infantry divisions and of separate infantry brigades, and to the light infantry battalions (TOE 7-100H) of the separate light infantry brigades.

#### GENERAL EMPLOYMENT

The infantry battalion is the basic maneuver unit of the infantry division and separate brigade. The battalion fights as part of a brigade and is normally supported by field artillery, air defense artillery, and engineers. Other combat support and combat service support elements are attached or placed in support as required and available. The battalion is well suited for combat operations where vehicular mobility is limited, such as in built-up areas.

The battalion should be able to move rapidly by all means of transportation. Therefore, it is considered necessary for all infantry battalions to have some training in airmobile operations.

#### CORE TRAINING TASKS

The core training tasks are listed in Table 5.1 together with the references describing them in detail. The selection was based on analysis of the battalion TOE; ARTEP 7-15, June 1979; and Field Manuals 7-20, The Infantry Battalion; 7-10, The Infantry Company; and 71-101, Infantry and Airborne Division Operations.

ARTEP 7-15 and FM 7-20 together describe the totality of the training tasks for a fully trained infantry battalion. The discussion below gives the rationale for omission of certain training tasks as core tasks. Many of the omitted tasks are, in fact, preliminary training exercises necessary to achieving proficiency in the core tasks or apply almost exclusively to airmobile or airborne infantry battalions.

TABLE 5.1  
CORE TRAINING TASKS

SUBELEMENT/TASK

<u>Rifle Squad</u>	<u>Reference (ARTEP 7-15)</u>
Movement to Contact	Section 9-1
Area Reconnaissance Patrol	Section 9-3
Clear an Urban Area	Section 9-4
Defense of an Urban Area	Section 9-5
Forced March (Live Fire)	Section 9-6
Antiarmor Fire Support	Sections* 10-5, 10-6, 10-7
 <u>Rifle Platoon</u>	
Movement to Contact	Section 8-1
Hasty Attack	Section 8-2
Antiarmor Ambush	Section 8-3
Attack of an Urban Area	Section 8-4
Area Reconnaissance Patrol	Section 8-5
 <u>Mortar Platoons/Sections</u>	
Indirect Fire Support (heavy mortar)	Section 7-24A
Indirect Fire Support (81mm mortar)	Section 7-25A
 <u>Antitank Platoon/Section/Squad</u>	
Antitank Fire Support	Sections* 7-27 or 10-4
 <u>Scout Platoon/Squad</u>	
Screening Mission	Section 7-19
Area Reconnaissance with Armor Option	Section 7-20
Crew Live Fire Exercise	Section 7-23
 <u>Redeye Platoon</u>	
Air Defense Fire Support	Section 7-29

---

\* Depending on AT weapons issued.

TABLE 5.1 (Cont.)  
CORE TRAINING TASKS

<u>Rifle Company</u>	<u>Reference (ARTEP 7-15)</u>
Movement to Contact	Section 7-1
Hasty Attack	Section 7-2
Deliberate Attack	Section 7-3
Night Attack	Section 7-4
Attack of an Urban Area	Section 7-5
Defense	Section 7-6
Defense of an Urban Area	Section 7-7
Night Withdrawal	Section 7-8
Delay	Section 7-9
Airmobile Assault	Section 7-12
<u>Battalion</u>	
Movement to Contact	Section 6-1
Hasty Attack	Section 6-2
Deliberate Attack	Section 6-3
Night Attack	Section 6-4
Attack of an Urban Area	Section 6-5
Defense	Section 6-6
Defense of an Urban Area	Section 6-7
Night Withdrawal	Section 6-8
Delay	Section 6-9
Airmobile Assault	Section 6-11

### Squad Level

The Ambush and Antiarmor Ambush tasks are deleted as core tasks at this level because they have many common combat skills. The training in these skills can be incorporated into the platoon task of antiarmor ambush.

### Platoon Level

Zone Reconnaissance Patrol is deleted because of the expected relative infrequency of requirements for this task. Further, the fundamentals of this task are covered in the squad task, Area Reconnaissance Patrol.

### Battalion Level

Exploitation and Pursuit are deleted as battalion training tasks. These tasks include most of the tactical elements covered in "movement to contact" and the "hasty attack." Further, it is expected that mechanized and armored units will be used in Europe for exploitation and pursuit.

## FACTORS INFLUENCING ACCOMPLISHMENT OF CORE TASKS

### Stationing

The component companies of infantry battalions, with a few minor exceptions, are stationed in separate towns that are distant from each other. In some cases, companies are further divided between two towns. All infantry battalions usually assemble for AT but most IDT assemblies are by company.

### Personnel Turbulence

Infantry battalions, like other RC units, have a significant degree of turbulence resulting from many factors. Precise data are not available, but several infantry battalion commanders and Readiness Region and Group personnel have estimated that at least 25% of the members of a battalion at any given time are not with the unit 1 year later. These estimates are in accord with turbulence data on the total Army Selected Reserve. High turbulence rates result in repetition of lower level

training and inhibit development of teamwork within squads, sections, and platoons.

#### Personnel Strength

RC infantry battalions are authorized either full structure strength or AL02, which is about 10% less.<sup>1</sup> Virtually all of the RC infantry battalions are now understrength. The average strength is 67% and ranges from 28% to 113%. About one-seventh of the battalions are below 50% of wartime authorized strength. Most of the personnel shortages are concentrated in the rifle platoons because of administrative and maintenance workloads. This understrength inhibits effective training of squads and platoons and creates additional postmobilization training requirements.

Various programs under way are designed to increase the strength of RC units, but the success of these programs is not yet clear. Experience has shown that RC infantry units have more difficulty in recruiting and retention than the other RC combat arms units.

#### Training Facilities

The training facilities available to RC infantry units are generally the same as with other RC maneuver battalions. The facilities vary widely in quality and accessibility. Usually, the nearest available field training site requires several hours of travel. The negative impact of lack of adequate facilities on the effectiveness of IDT training is obvious, particularly when it prevents hands-on training with major mission equipment items and tactical training at realistic distances.

#### ACCOMPLISHMENT OF CORE TASKS

The limited time available for peacetime training, the lack of adequate training facilities except during AT, and personnel status dictate that all core tasks involving field training at the company and battalion levels can, in fact, be accomplished only after mobilization.

---

<sup>1</sup>Actually, 100% for officers and 90% for enlisted men.

However, some training in company and battalion core tasks can be conducted in peacetime by use of map exercises, command post exercises, and other methods not involving use of subordinate units on the ground.

Upon mobilization it can be expected that there will be some personnel losses and that the battalions will be brought up to about AL02 (90%) strength before deployment. Consequently, there will be changes within squads and platoons and a resulting need to refire the weapon crews.

In summary, all battalion task force and company team tasks involving field exercises with troops are postmobilization tasks because of the characteristics of the RC environment. Additionally, the core training tasks involving firing of weapons should be repeated as post-mobilization training tasks because of changes of assignments and influx of personnel.

#### PEACETIME ACCOMPLISHMENT

The core tasks, other than those summarized above for accomplishment after mobilization, are capable of being accomplished in peacetime by a well-managed infantry battalion over a 3-year period. This estimate is based on the following assumptions:

- The collective training of the battalion is focused on the core training tasks.
- There are no other mandatory collective training tasks prescribed except possibly some that can be executed concurrently with the core training tasks.
- The battalion has at least 70% or more of its wartime authorized strength.
- Urban area mockups are available for either IDT or AT.

One possible 3-year schedule is given in Table 5.2. This schedule is based on achieving and maintaining proficiency in core tasks rather than merely scheduling a specified number of training assemblies for each core task. In the preparation of this schedule consideration was given to the time necessary for individual skill training. Variances in the levels of proficiency that can be attained during IDT are to be expected because of differences in the availability of ranges, training areas, and other aspects of training support.

Although not shown in Table 5.2, training in company and battalion core tasks would also be conducted but by means of map exercises, command post exercises, and other means not involving field exercises with troops.

#### POSTMOBILIZATION ACCOMPLISHMENT

It is estimated that at least 38 training days will be required for postmobilization training of RC infantry battalions. This estimate is based on the assumptions listed below.

- Time to achieve proficiency in the core tasks will, on the average, be as given in Table 5.3.
- Appropriate ranges will be available as required.
- The battalion is at 80% or more of wartime authorized strength in personnel and equipment.
- The battalion will not be reequipped with different types of weapons or other major items.
- Helicopters will be available when needed and in adequate numbers.

TABEL 5.2  
POSSIBLE PEACETIME TRAINING PROGRAM

SUBELEMENT/TASK	<u>1st Year</u>	<u>2nd Year</u>	<u>3rd Year</u>
<u>Rifle Squad</u>			
Movement to Contact	X	X	
Area Reconnaissance Patrol	X	X	X
Clear an Urban Area		X	
Defense of an Urban Area			X
Forced March (Live Fire)	X	X	X
Antiarmor Fire Support	X	X	X
<u>Rifle Platoon</u>			
Movement to Contact	X	X	
Hasty Attack	X	X	
Antiarmor Ambush			X
Attack of an Urban Area			X
Area Reconnaissance Patrol		X	X
<u>Mortar Platoons/Sections</u>			
Indirect Fire Support (heavy mortar)	X	X	X
Indirect Fire Support (81mm mortar)	X	X	X
<u>Antitank Platoon/Section/Squad</u>			
Antitank Fire Support	X	X	X
<u>Scout Platoon/Squad</u>			
Screening Mission	X	X	X
Area Reconnaissance with Armor Option	X	X	X
Crew Live Fire Exercise	X	X	X
<u>Redeye Platoon</u>			
Air Defense Fire Support	X	X	X

\* Depending on AT weapons issued.

TABLE 5.2 (Cont.)  
 POSSIBLE PEACETIME TRAINING PROGRAM

<u>Rifle Company</u>	<u>1st Year</u>	<u>2nd Year</u>	<u>3rd Year</u>
Deliberate Attack <sup>1</sup>	X	X	X
Attack of an Urban Area <sup>1</sup>		X	
Defense <sup>1</sup>	X		X
Defense of an Urban Area <sup>1</sup>			X
<hr/>			
<u>Battalion</u>			
Deliberate Attack	X	X	X
Attack of an Urban Area		X	
Defense	X		X
Defense of an Urban Area <sup>1</sup>			X

<sup>1</sup>Command post and similar exercises without troops.

Table 5.3 shows the estimated training time for each core task to be accomplished after mobilization. The estimates are made to provide a basis for estimating the total postmobilization time required before deployment. Some of the core tasks may require more time and some less time. However, it is considered that overall the total time shown will be the minimum required by most RC infantry battalions under the assumptions listed above.

The listing in Table 5.3 does not indicate a prescribed sequence for performance. For example, it is possible that one company of the battalion might be engaged in refresher firing while simultaneously another company is training in other core tasks.

The estimated 35 days for postmobilization training covers training time only. This estimate does not include time for individual skill training that may be necessary, preparations to start training after closing at the mobilization station, delay in receipt of fillers, waiting for range and training area availability, and similar factors. This time may not be completely additive to collective training time.

#### HISTORICAL EXPERIENCE

##### Army Training Program (ATP)

Same as that described in Section 4.

##### Mobilization Experience<sup>1</sup>

In the 1968 mobilization, five infantry battalions were mobilized. Four of these battalions were part of the Selected Reserve Force and were authorized 58 training assemblies each year instead of the normal 48 in order to achieve high levels of readiness. The characteristics of these battalions at that time are shown in Table 5.4.

---

<sup>1</sup>Review and Analysis of Recent Mobilizations and Deployments of US Army Reserve Components, Research Analysis Corporation, RAC-CR-67, October 1972.

TABLE 5.3  
ESTIMATED POSTMOBILIZATION TRAINING TIME  
(days)

<u>Core Task</u>	<u>Estimated Time</u>
<u>Refresher Firing</u>	14
<u>Mechanized Infantry Crew/Squad</u>	
Forced March (Live Fire)	
M113 Crew Firing Proficiency	
Antitank Fire Support	
<u>Antitank Platoon/Section/Squad</u>	
Antitank Fire Support	
<u>Mechanized Infantry Platoon</u>	
Defense Against Aircraft (Live Fire)	
<u>Mortar Platoons/Sections</u>	
Indirect Fire Support	
<u>Redeye Section</u>	
Air Defense Support	
<u>Scout Platoon</u>	
Zone Reconnaissance and Hasty Attack	
<u>Company Team</u> <sup>1</sup>	
Movement to Contact	[ 2
Hasty Attack	3
Deliberate Attack	3
Defense	2
Delay High Risk	2
Night Attack	2
Defense of a Built-Up Area	(Map Exercise) <sup>2</sup>
<u>Battalion Task Force</u> <sup>1</sup>	
Movement to Contact	[ 1
Hasty Attack	2
Deliberate Attack	2
Defense	2
Delay High Risk	2
Night Attack	2
Defense of a Built-Up Area	(Map Exercise) <sup>2</sup>
Total	35

<sup>1</sup>It is assumed that some training in these core tasks was conducted in peacetime using map exercises and other techniques not involving troop units.

<sup>2</sup>Concurrent with other training.

TABLE 5.4

CHARACTERISTICS OF INFANTRY BATTALIONS MOBILIZED IN 1968

Unit	Personnel Status		Training Estimates (weeks required)	
	% Assigned at Alert	% Mobilized	Before Mobilization	Reevaluation at Mobilization
100/42 Inf	78	61	8	13
1/299 Inf*	89	79	8	13
2/299 Inf*	91	82	8	13
1/137 Inf*	97	93	8	11
2/137 Inf*	96	92	8	11

\* Part of the Selected Reserve Force.

All the battalions underwent some minor reorganization after mobilization and required about 13 weeks to complete the 11-week infantry battalion ATP.<sup>1</sup>

<sup>1</sup>One battalion required only 12 weeks and one battalion required 15 weeks. The latter battalion was held back by some delays in fill of personnel and equipment shortages.

## POSTMOBILIZATION TRAINING FACILITIES REQUIREMENTS

- Ranges for refresher training and evaluation of proficiency of the following:

### Antitank Support

- TOW
- DRAGON
- LAW
- 90mm and 106mm recoilless rifles

### Indirect Fire Support

- 81mm mortar
- 4.2-inch mortar

### Air Defense Support

- REDEYE/STINGER

### Reconnaissance and Hasty Attack

(live fire)

- Maneuver area for an infantry battalion for the training tasks listed below to include artillery, helicopter, and tactical air support.

- Movement to contact
- Hasty attack
- Deliberate attack
- Defense
- Delay high risk
- Night attack
- Night withdrawal
- Delay
- Airmobile assault

- Urban area mockup

- Platoon attack and defense<sup>1</sup>

---

<sup>1</sup>For refresher training as required.

SECTION 6  
CANNON ARTILLERY

THE FIELD ARTILLERY SYSTEM

The field artillery system is a combination of people, equipment, and procedures that together produce accurate artillery fire. It consists of five essential elements:

- Target acquisition, which includes targets located by an observer or acquisition devices, the reporting of target locations, calls for fire to the fire direction center, and the adjustment of fires.
- The fire direction center (FDC) evaluates target information, determines firing data, makes decision as to type ammunition and amount of fire, and transmits fire commands to the firing units.
- The firing battery sets the firing data on the weapons, prepares ammunition, and fires the mission.
- Survey determines precise weapon and target locations.
- Meteorology provides atmospheric data for ballistic corrections. (Met data are provided to the battalion and battery FDCs.)

Since it takes a combination of these elements to attack a target successfully, the core tasks for cannon artillery are stated in terms which encompass the system rather than subunits.

CORE TASKS

The selection of the core training tasks was based on analysis of the cannon artillery TOEs; ARTEPS 6-105, 6-165, and 6-365, September 1979; and Field Manuals 6-40 (Field Artillery Cannon Gunnery), 6-50 (Field Artillery Cannon Battery), and 6-20 (Fire Support in Combined Arms Operations), which together describe the totality of the training tasks for a fully trained artillery battalion.

Table 6.1 lists the derived core training tasks. The tasks that are not included are those common to all units or are subsumed within the designated core training tasks.

The nuclear capability of the 155mm and 8-inch howitzer battalions has not been retained as a core training task because the task is complex and presents a difficult training problem for RC units.<sup>1</sup> Theoretically, the retention of this core training task would cause the enemy to consider all 155mm and 8-inch howitzer battalions as being nuclear capable. However, if believed necessary, this advantage can be retained if Active Component nuclear battalions furnish the few weapons assemblers and other personnel needed to provide a nuclear firing capability to designated deployed RC battalions.

#### FACTORS INFLUENCING ACCOMPLISHMENT OF CORE TASKS

##### Doctrine

US techniques for employing artillery rely on organizational and fire control procedures to provide these capabilities:

- Attack of several individual targets simultaneously
- Massing the fires of separated units onto a single target

To achieve these capabilities, some combined battalion/battery level training must take place during both IDT and AT.

Field artillery tactical missions establish fire support responsibilities and determine the relationship with a maneuver unit or another artillery unit. The standard tactical missions are direct support (DS), reinforcing (R), general support reinforcing (GSR), and general support (GS).

---

<sup>1</sup>The study, The Nuclear Role for US Army Reserve Components, describes in detail the problems involved. The study recommends retention of this task as a core training task and states that additional training assemblies and other actions would be required. See DNA 5091F, Defense Nuclear Agency, January 1980.

TABLE 6.1  
CORE TRAINING TASKS

<u>Battalion/Battery</u>	<u>References</u>
<u>Registration</u>	ARTEPs 6-105, 6-165, and 6-365, Chapters 2 and 3*
Precision	FM6-40, Chapter 5
Center of impact	FM6-40, Chapter 5
High burst	FM6-40, Chapter 5
Radar registration	FM6-40, Chapter 5
High angle registration	FM6-40, Chapter 9
<u>Other gunnery missions</u>	
Apply initial and subsequent MET corrections	FM6-40, Chapter 6
Battalion mass (battery adjust)	FM6-40, Chapter 2
Fire for effect (inside limits)	FM6-40, Chapter 4
Direct fire	FM6-50, Chapter 12
Untrained observer	FM6-40, Chapter 12
Battalion/battery preparation	FM6-40, Chapter 12, FM6-20, Chapter 4
Battalion TOT	FM6-40, Chapter 2
Battalion mass (radar adjust)	FM6-40, Chapters 2 and 15
Battalion mass (VT in effect)	FM6-40, Chapters 2 and 4
Aerial observer	FM6-40, Chapter 12
Planned/immediate suppression	FM6-40, Chapter 12, FM6-20, Chapter 3
Irregular target	FM6-40, Chapter 12
High angle (adjust/fire for effect)	FM6-40, Chapter 9
Fire for effect (outside transfer limits)	FM6-40, Chapter 5
Moving observer	FM6-40, Chapter 12
Final protective fires (105mm and 155mm)	FM6-40, Chapter 12
Nuclear (155 mm, 8-inch)	FM6-40, Chapter 13
<u>Communications</u>	
Establish tactical/admin. nets (ECM environment)	FM6-50, Chapter 13, AR380-5
<u>Tactical operations</u>	
Reconnoiter, select, and occupy positions day/night/NBC	FM6-50, Chapters 3, 4, 5, and 6
Defend position	FM6-50, Chapter 7
Perform position area survey	FM6-2, Chapter 2
Occupy position from march column (hipshoot)	FM6-50, Chapter 6
Target area survey	FM6-2, Chapter 2
Prepare company-level final protective fires and target lists†	FM6-40, Chapter 12
Prepare battalion (task force) level fire support plan†	FM6-20, Chapters 4 and 5
Prepare brigade level fire support plan†	FM6-20, Chapters 4 and 5

\*ARTEP references apply to all core tasks.

†Direct support battalions only.

Artillery battalions having a direct support mission specified in their TOE must do some training with the supported maneuver unit. This type of training is essential for the battalion Fire Support Teams (FIST), and the Fire Support Officers (FSO) that work directly with the maneuver units. All other RC cannon artillery units normally train for the reinforcing and general support missions.

### Stationing

The component batteries of RC artillery battalions are usually separated geographically. This separation does not, however, preclude battalion/battery combined training. For example, it is common for elements of battalion/battery fire direction and communication sections to train together during IDT. Similarly, radio and/or telephone communications can be used to link batteries for integrated training in the same manner that these communications link batteries together during tactical operations.

RC artillery battalions, like other RC units, experience a high degree of turbulence resulting from many factors, including prior service personnel who enlist for only 1 year. Most prior service personnel enlisting in artillery battalions have not previously served in such units. Precise data are not available, but generally about 25% or more of the members of an artillery battalion at any given time are not with the unit 1 year later.

### Personnel Strength

Most RC cannon artillery battalions are organized at 80% of full structure strength, or ALO3. Many of the 119 battalions are now under-strength. The average strength is 71% and ranges from 38% to 108%. The artillery battalions organic to divisions or separate brigades have an average strength of 67% and separate artillery battalions average 74%.<sup>1</sup>

---

<sup>1</sup>Based on October 1979 Unit Status Reports.

Cannon artillery units are structured for sustained, 24-hour operations (e.g., the howitzer section of an 8-inch self-propelled battery contains 13 enlisted personnel including 8 cannoneers).<sup>1</sup> Thus, a well-trained but understrength RC artillery unit, if deployed in an emergency situation, should be able to operate effectively but probably not on an around-the-clock basis. This could be an acceptable limitation for a general-support artillery battalion but not for a divisional or brigade direct support battalion. There are various programs underway which are designed to increase the strength of RC units, but the success of these programs is not yet determined.

### Training Facilities

The training facilities available to RC artillery units for IDT vary widely. However, there are sufficient facilities and support for virtually all cannon artillery battalions to fire at least once about every 3 months. In addition, there are many opportunities for hands-on training activities that do not require extensive field facilities or the assembly of entire batteries or battalions. For example:

- The M31 field artillery trainer (14.5mm)--this subcaliber training device can be used effectively in the combined training of cannon crews, fire direction personnel, and forward observers. The M31 requires a range roughly the size of a football field.
- Command post exercise (CPX)--a tactical exercise which involves the command, communications, support, and fire direction personnel of the battery and/or battalion.
- Command post exercise (CPX) with base piece--this is a live firing exercise involving only one cannon section per battery. In this type exercise, a unit (battalion or battery) can engage in all the ARTEP missions with only about 50% of the ammunition and personnel required for a full-scale field training exercise (FTX).

---

<sup>1</sup>At full strength (AL01).

- Tactical exercise without troops (TEWT)--the disposition and/or movement of troops and equipment is discussed and planned in a field location. Quite often reconnaissance, selection, and occupation of firing positions (RSOPs) is conducted using this training mode. In this regard, access to an area suitable for RSOP training during IDT is considered to be essential for readiness.

#### Advanced Technology

There are a number of items of new equipment,<sup>1</sup> such as the laser rangefinder and fire direction/survey calculators (TI-59), that will appreciably improve operational efficiency and reduce training requirements. RC units, in particular, will benefit from these technological advances because of the reduced training requirements in the key but difficult-to-train fire direction and survey sections. On the other hand, the issuance of certain new types of ammunition, such as COPPERHEAD, may tend to increase training requirements.

#### ACCOMPLISHMENT OF CORE TRAINING TASKS

All the core training tasks are believed to be capable of accomplishment in peacetime by a well-managed RC artillery battalion over a 3-year period. This estimate is based on the following:

- Virtually all battalions have access to adequate facilities and sufficient support to conduct live fire training exercises at least once a quarter.
- Devices and communications are available for the training during IDT of forward observers and fire direction centers and for the conduct of meaningful battery/battalion command post exercises.
- Field training in reconnaissance, selection, occupation and defense of position can be readily accomplished during AT.
- Duties of gun sections are relatively simple, limited in scope, and repetitive in nature.

---

<sup>1</sup>New equipment and ammunition rounds have not as yet been issued to RC battalions.

The attainment of proficiency in the assembly and firing of nuclear rounds (8-inch and 155mm battalions) in peacetime is a very difficult goal for RC artillery battalions. Very few RC artillery battalions have achieved proficiency in the nuclear mission under current training practices.

#### PEACETIME ACCOMPLISHMENT

A suggested 3-year program for a battalion for accomplishment of all the core training tasks in peacetime is shown in Table 6.2. The program is based on achieving and maintaining proficiency in the core training tasks listed and not on a specified number of training hours for each training task. It is estimated that the suggested program, or equivalent, can be successfully completed if the following conditions prevail.

- The battalion is given specific mission-related training goals (core tasks) and achievement of these goals is evaluated during AT.
- No other mandatory training is prescribed except those that can be executed concurrently with the core training tasks.
- The battalion has at least 70% of its wartime authorized strength.

#### DEPLOYABILITY

The core tasks included in the first year of the suggested program encompass the basic artillery tasks:

- Move (reconnoiter, select, occupy, and defend its position)
- Shoot (register and mass/transfer fires)
- Communicate

Achievement of proficiency in these first-year tasks is considered sufficient to qualify an artillery battalion for deployment without further postmobilization training. This conclusion is based on the premise that artillery battalions can significantly contribute to the land battle after demonstrating proficiency in only a relatively limited number of type fire missions.

TABLE 6.2  
SUGGESTED PEACETIME TRAINING PROGRAM

<u>Battalion/Battery</u>	<u>1st year</u>	<u>2d year</u>	<u>3d year</u>
<u>Registration</u>			
Precision	x	x	x
Center of impact	x	x	x
High burst	x	x	x
Radar		x	x
High angle			x
<u>Other gunnery missions</u>			
Apply initial and subsequent MET corrections	x	x	x
Battalion mass (battery adjust)	x	x	x
Fire for effect (inside limits)	x	x	x
Direct fire	x	x	x
Untrained observer	x	x	x
Final protective fires (105/155mm direct support battalions)	x	x	x
Nuclear (155mm, 8-inch)			x
Battalion/battery preparation		x	x
Battalion TOT		x	x
Battalion mass (radar adjust)		x	x
Battalion mass (VT in effect)		x	x
Aerial observer		x	x
Planned/immediate suppression		x	x
Fire for effect (outside transfer limits)			x
Moving observer			x
Improved conventional munitions		x	x
<u>Communications</u>			
Establish tactical/admin. nets (ECM environment)	x	x	x
<u>Tactical operations</u>			
Reconnoiter, select, and occupy position day/night/NBC	x	x	x
Defend position	x	x	x
Perform position area survey	x	x	x
Prepare company-level final protective fires and target lists*	x	x	x
Occupy position from march column (hipshoot)		x	x
Perform target area survey		x	x
Prepare battalion (task force) level fire support plan)*		x	x
Prepare brigade level fire support plan*			x

\*Direct support battalions only.

## HISTORICAL EXPERIENCE

### Army Training Program

The Army Training Program (ATP) for field artillery batteries and battalions covered all types of towed and self-propelled cannon units including 105mm, 155mm, 175mm, and 8-inch weapons. The discussion that follows covers only the training of field artillery cannon units at the section level and higher (collective training).

The ATP<sup>1</sup> for the collective training of field artillery cannon battalions provided for a total of 13 weeks of training (nominally 44 hours per week) divided as follows:

- Basic unit training (through battery level) 7 weeks (308 nominal hours)
- Advanced unit training (battalion, groups, and division artillery) 6 weeks (264 nominal hours)

Basic unit training consisted of 202 nominal training hours devoted to general subjects covering individual training, battery proficiency tests, and 31 hours for commander's time, character guidance, and command information. The remaining 106 hours of basic unit training was devoted to section training. The schedule for each section included some time for "section operations" (OJT). The detailed schedule for selected sections is shown in Table 6.3.

Advanced unit training (battalion level) consisted of 264 hours with 100 hours devoted to training in general subjects not specifically related to artillery operations. The remaining 164 hours were devoted to mission-specific training which included a formal battalion Army Training Test (ATT), road marches and bivouacs, field exercises, and service practice in preparation for the test.

---

<sup>1</sup>ATP 6-100, Field Artillery Cannon Units, July 1968.

TABLE 6.3  
 FIELD ARTILLERY CANNON UNITS ATP  
 BASIC UNIT TRAINING FOR SELECTED SECTIONS

Training Task	Hours
<u>Battalion operations/FDC and battery FDC</u>	106
Artillery fires	(8)
Combat intelligence	(10)
Communications	(4)
Fire support coordination	(4)
Instruments	(4)
Liaison	(4)
Map reading	(7)
Organization/tactics of maneuver units	(6)
Section operations (OJT)	(51)
Survey	(8)
<u>Howitzer/gun section</u>	106
Ammunition, care/handling	(15)
Communications	(8)
Duties, Artillery recorder	(3)
Motor vehicles:	
(a) Difficult traction/field expedients	(15)
(b) Driving/care maintenance	(12)
Operation of FDC	(2)
Section operations (OJT)	(51)
<u>Survey section/survey information center</u>	106
Astronomic observations	(29)
Instruments	(8)
Map reading	(7)
Operation of FDC	(6)
Section operations (OJT)	(56)

The ATT usually lasted 2 to 3 days. It began during daylight hours with the battalion occupying a firing position area. Following this event, the battalion was given a new mission requiring a reconnaissance and selection of position (one daylight and one night occupation). The tested unit was also required to fire a mission from an emergency position (no prior reconnaissance). The gunnery missions required by the ATT were:

- Precision registration
- High burst registration
- Center of impact registration
- Battalion mass (battery adjust)
- High angle mission
- Illuminating mission
- Area adjustment (air and ground observers)
- Defense target (direct fire)
- H & I targets
- Apply MET and VE corrections
- Battalion TOT

#### Mobilization Experience

The 1968 Vietnam mobilization included five cannon artillery battalions. Of these, two battalions were deployed to Vietnam with only one being employed tactically as a battalion. The other battalion was dispersed to a series of fire support bases. Both battalions were "infused" with non-Reserve Component personnel soon after arrival in Vietnam to prevent having all personnel due to return to the United States at the same time.

All the mobilized artillery battalions were almost at full strength when mobilized. The five battalions were a mix of 105mm, towed, 155mm, towed, and one 155mm, self-propelled units. The time required by the battalions to complete the full Army Training Program, to include battalion Army Training Tests, varied from 10 to 16 weeks with the average being 13 weeks--the number of weeks in the Army Training Program for the collective training of a cannon artillery battalion. The data do not indicate any meaningful difference resulting from the caliber of the cannon or whether it is towed or self-propelled.

APPENDIX A  
ORGANIZATION DIAGRAMS

	<u>PAGE</u>
Figure A1. Tank Battalion	A-2
Figure A2. Tank Company	A-3
Figure A3. Combat Support Company, Tank Battalion	A-4
Figure A4. Mechanized Infantry Battalion	A-5
Figure A5. Mechanized Infantry Company	A-6
Figure A6. Combat Support Company, Mechanized Infantry Battalion	A-7
Figure A7. Light Infantry Battalion	A-8
Figure A8. Light Infantry Company	A-9
Figure A9. Combat Support Company, Light Infantry Battalion	A-10
Figure A10. Cannon Artillery Battalion	A-11
Figure A11. Cannon Artillery Battery	A-12

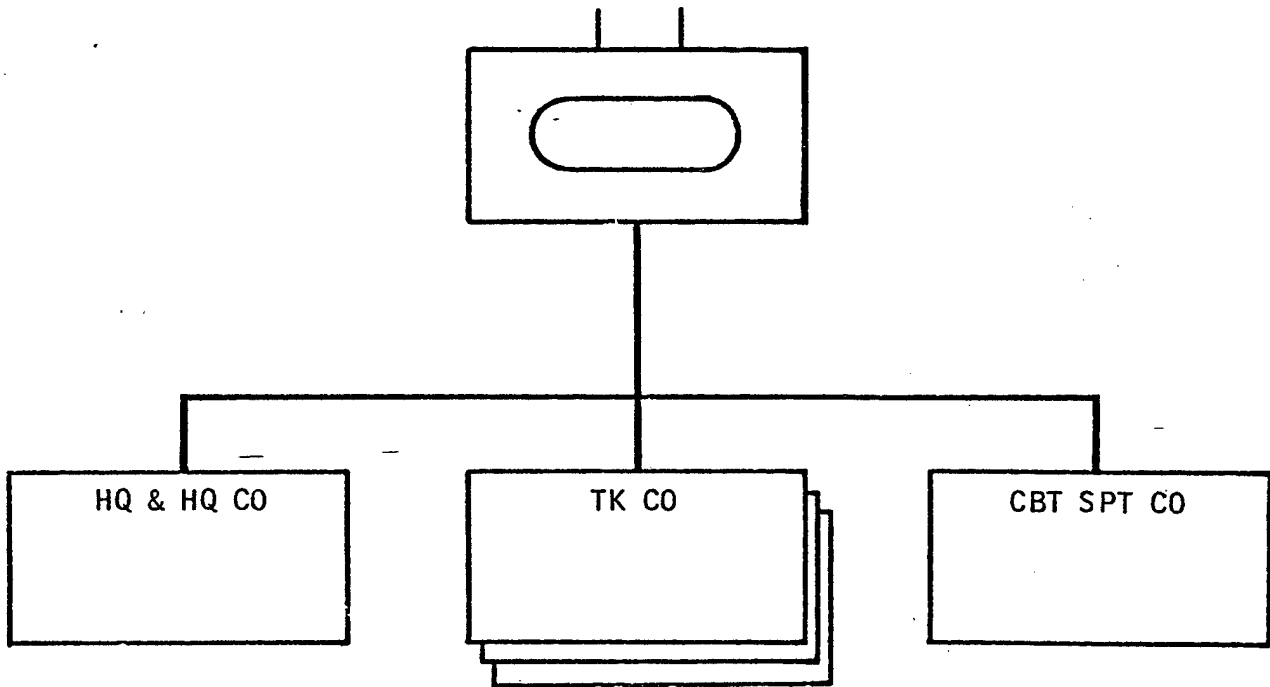

Figure A1. Tank Battalion

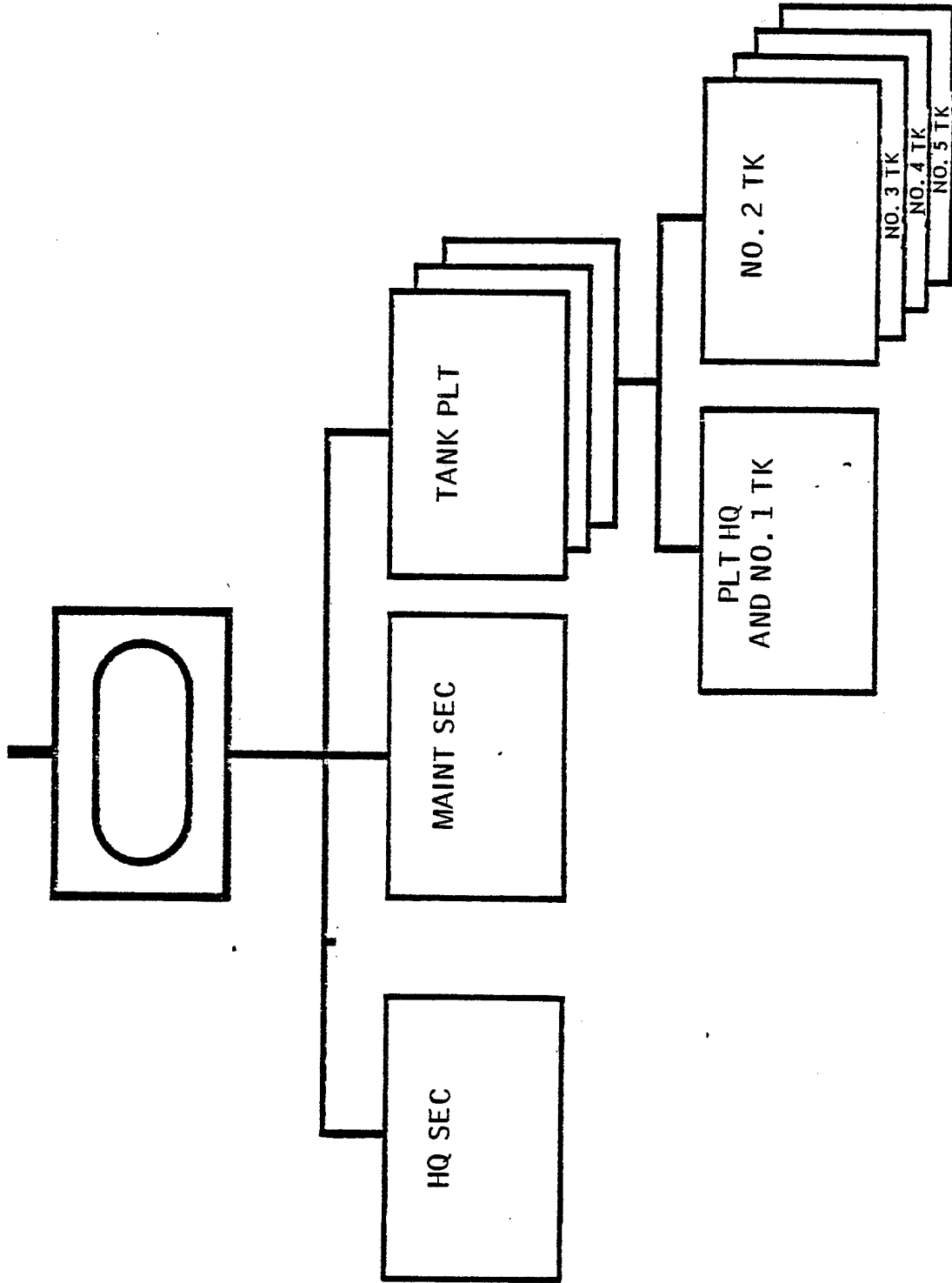

Figure A2. Tank Company

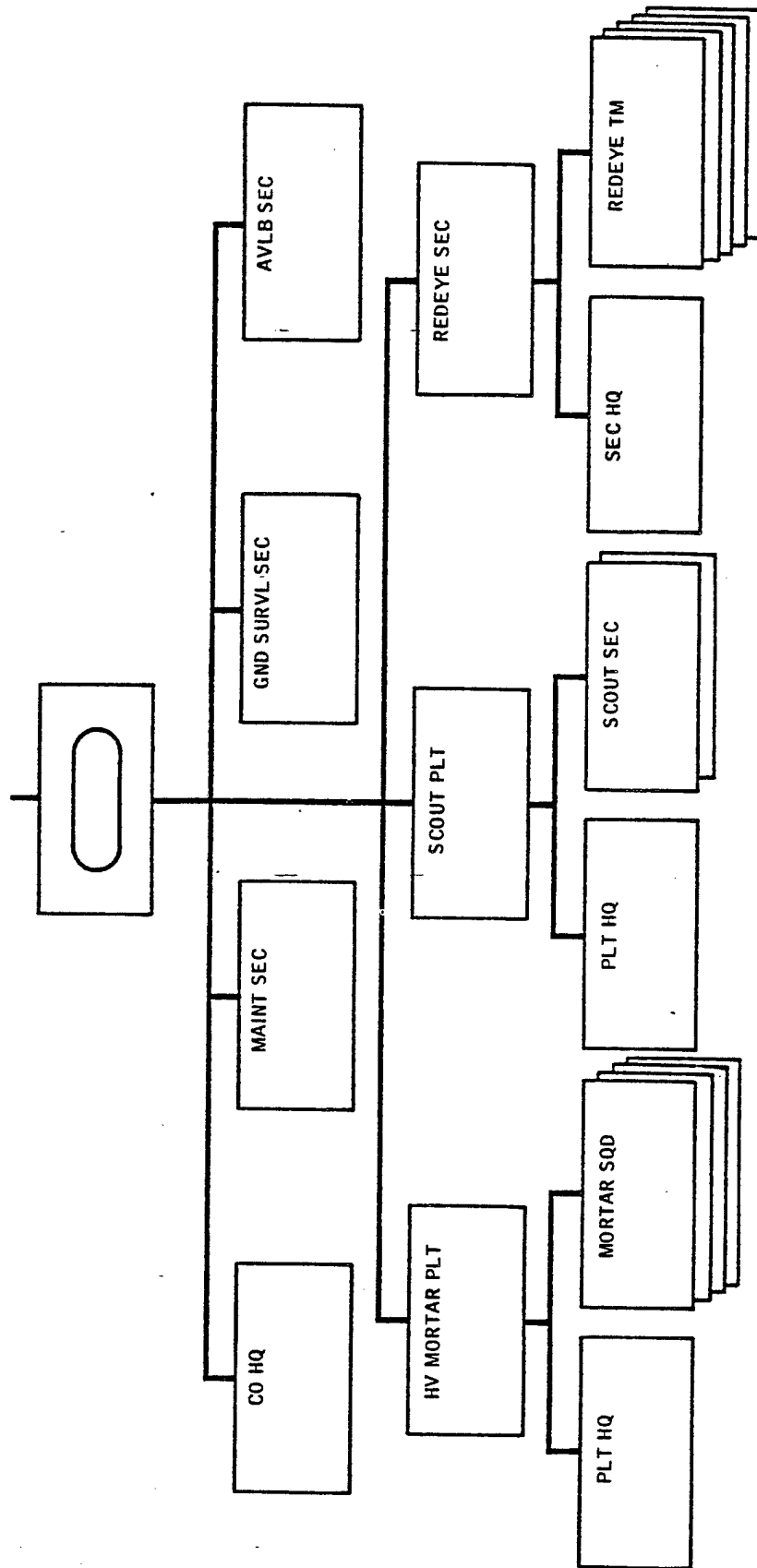

Figure A3. Combat Support Company, Tank Battalion

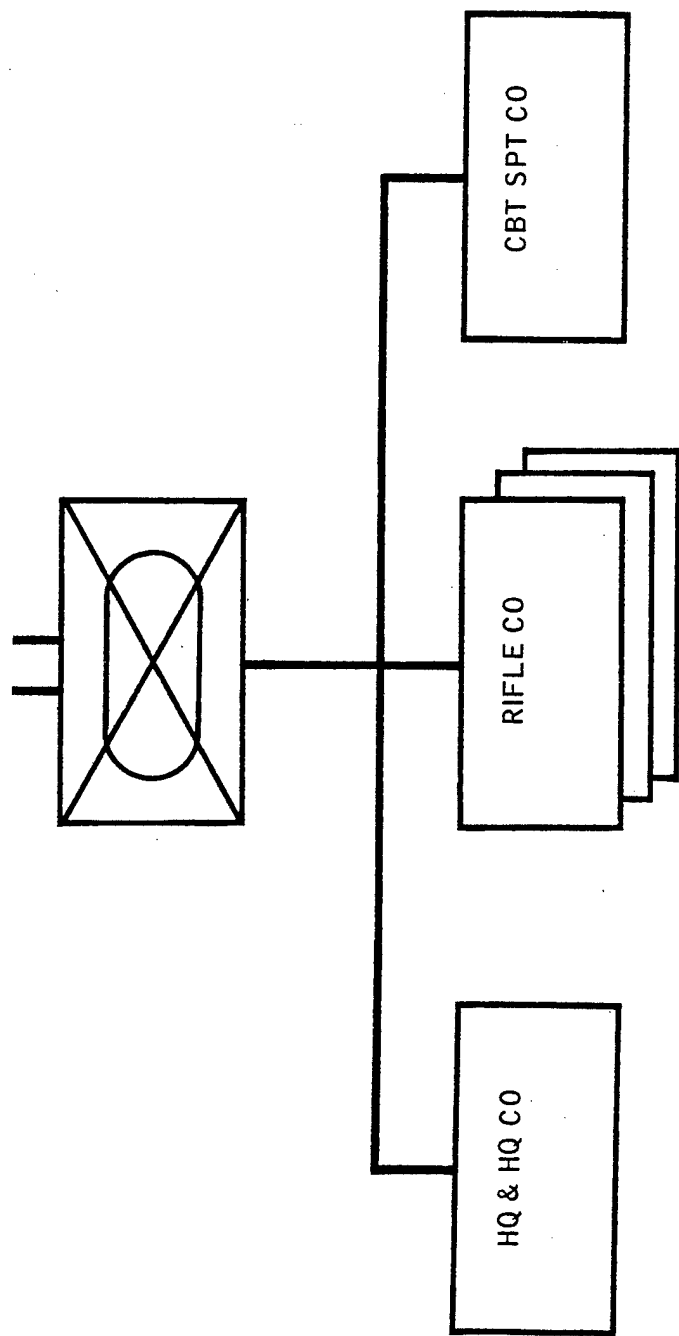

Figure A4. Mechanized Infantry Battalion

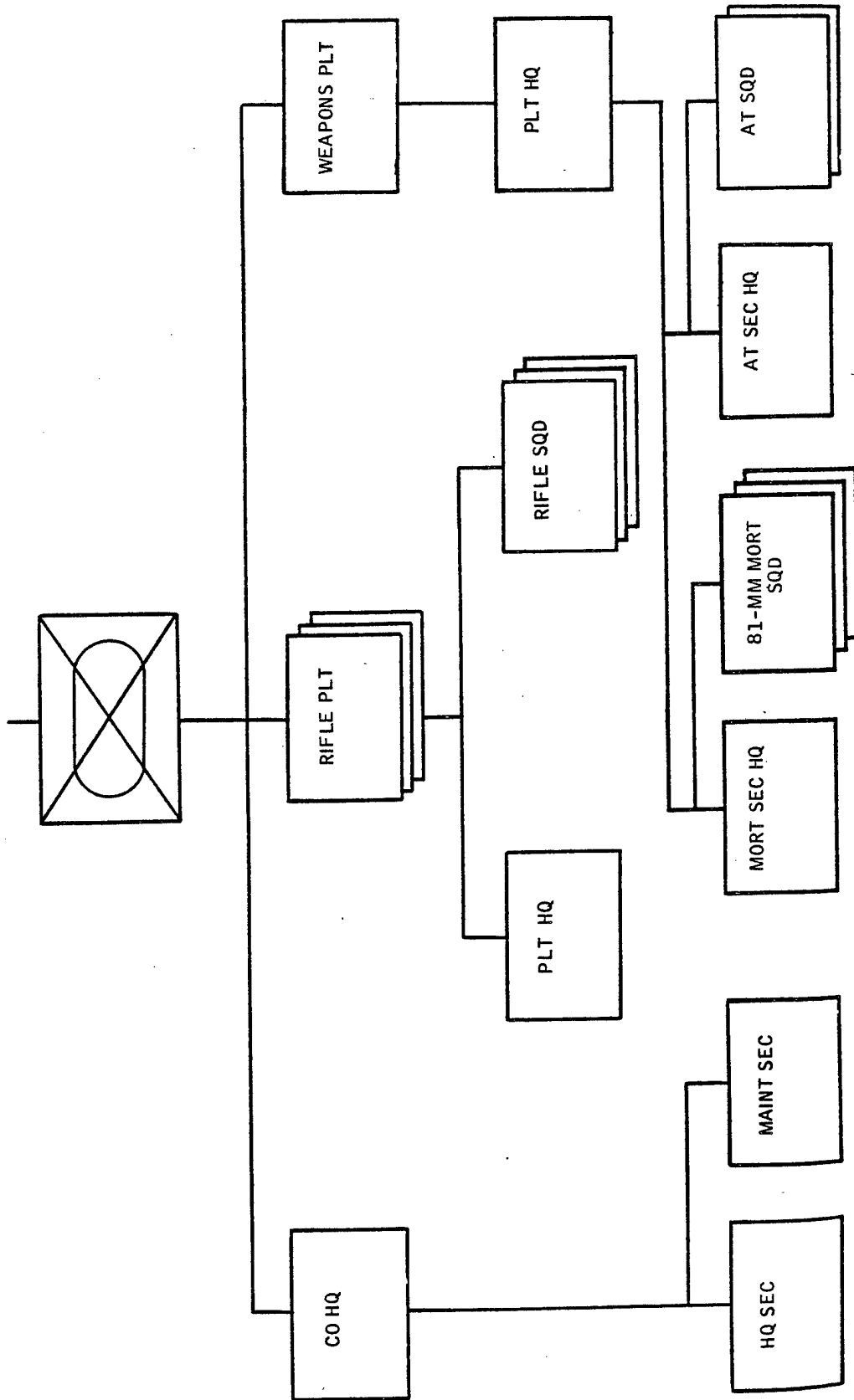

Figure A5. Mechanized Infantry Company

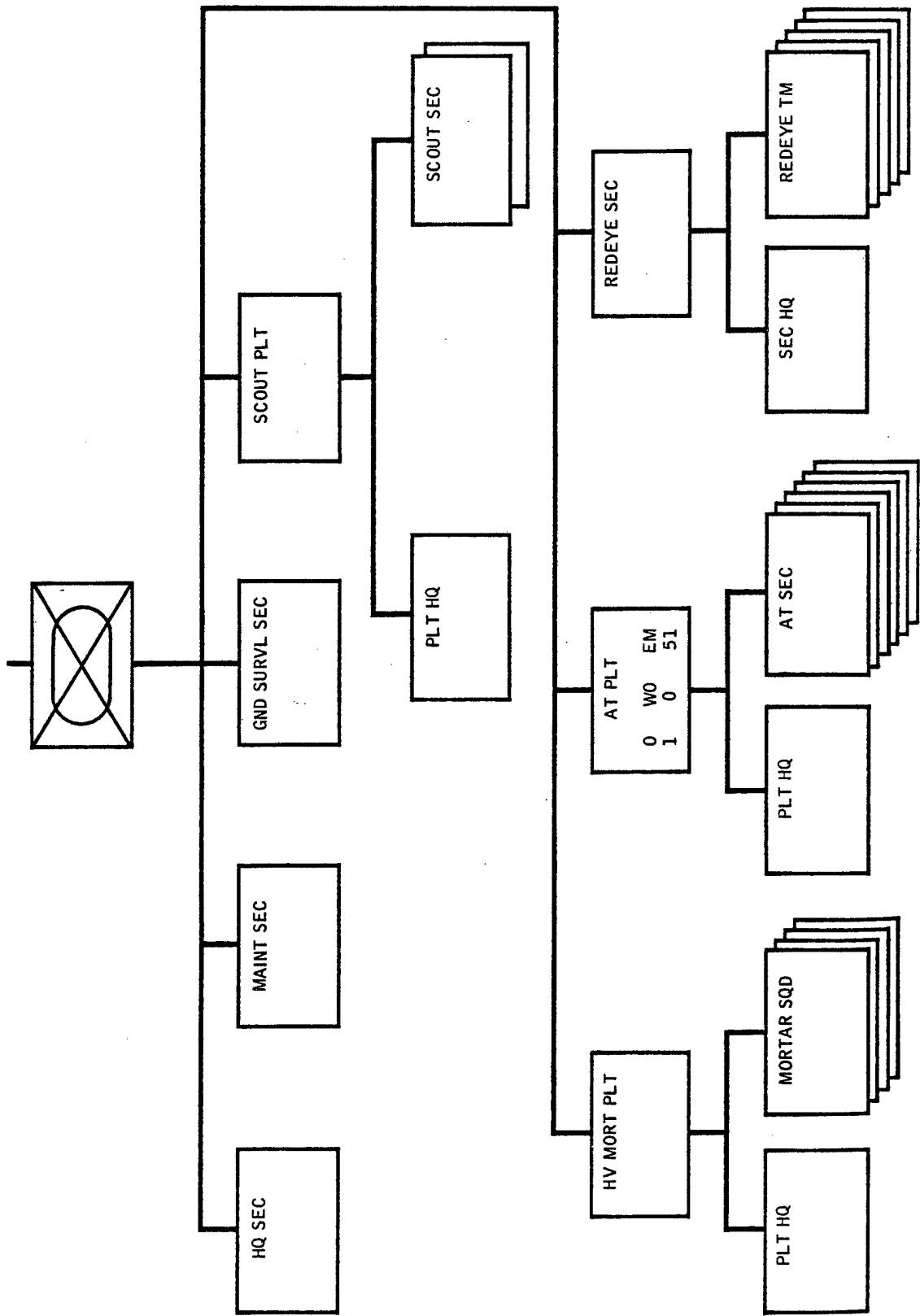

Figure A6. Combat Support Company, Mechanized Infantry Battalion

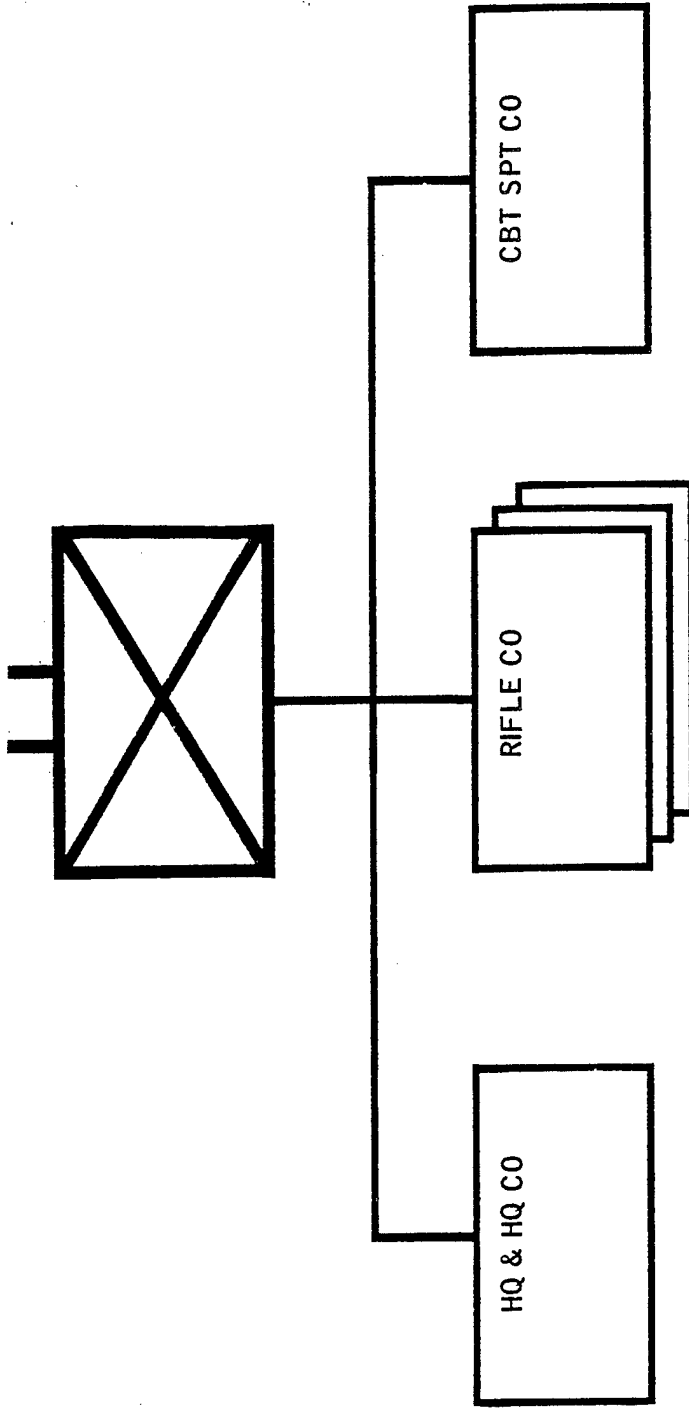

Figure A7. Light Infantry Battalion

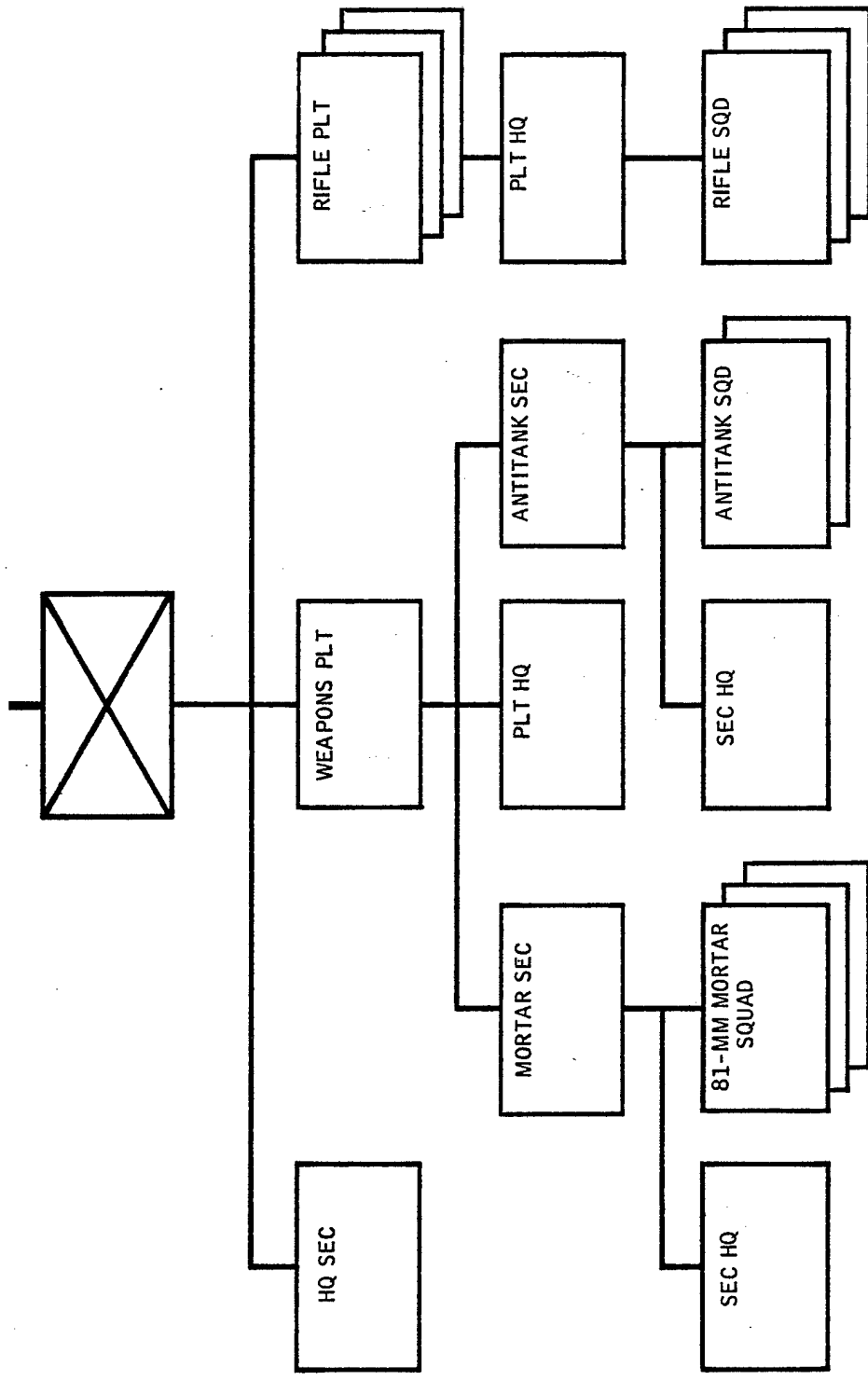

Figure A8. Light Infantry Company

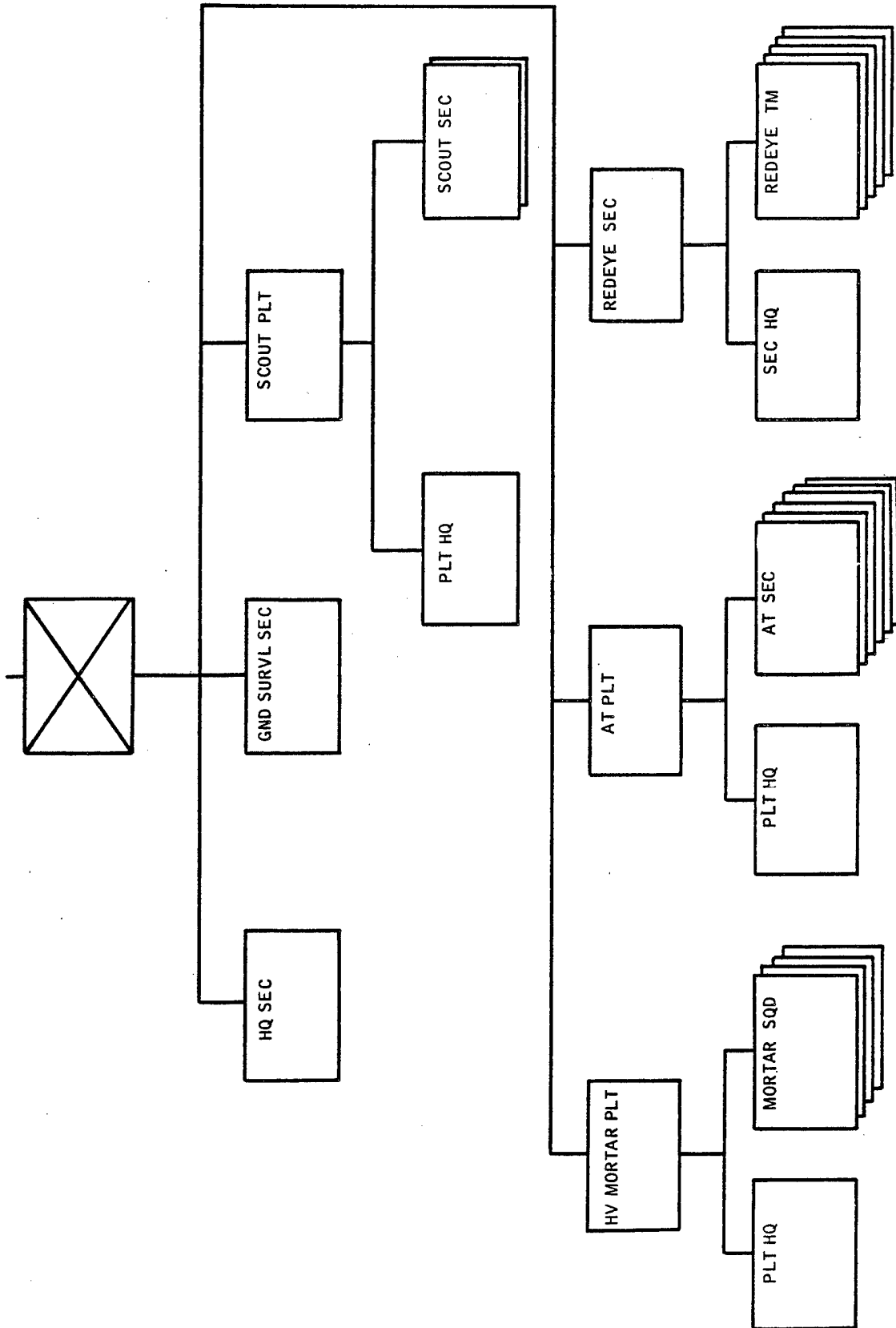

Figure A9. Combat Support Company, Light Infantry Battalion

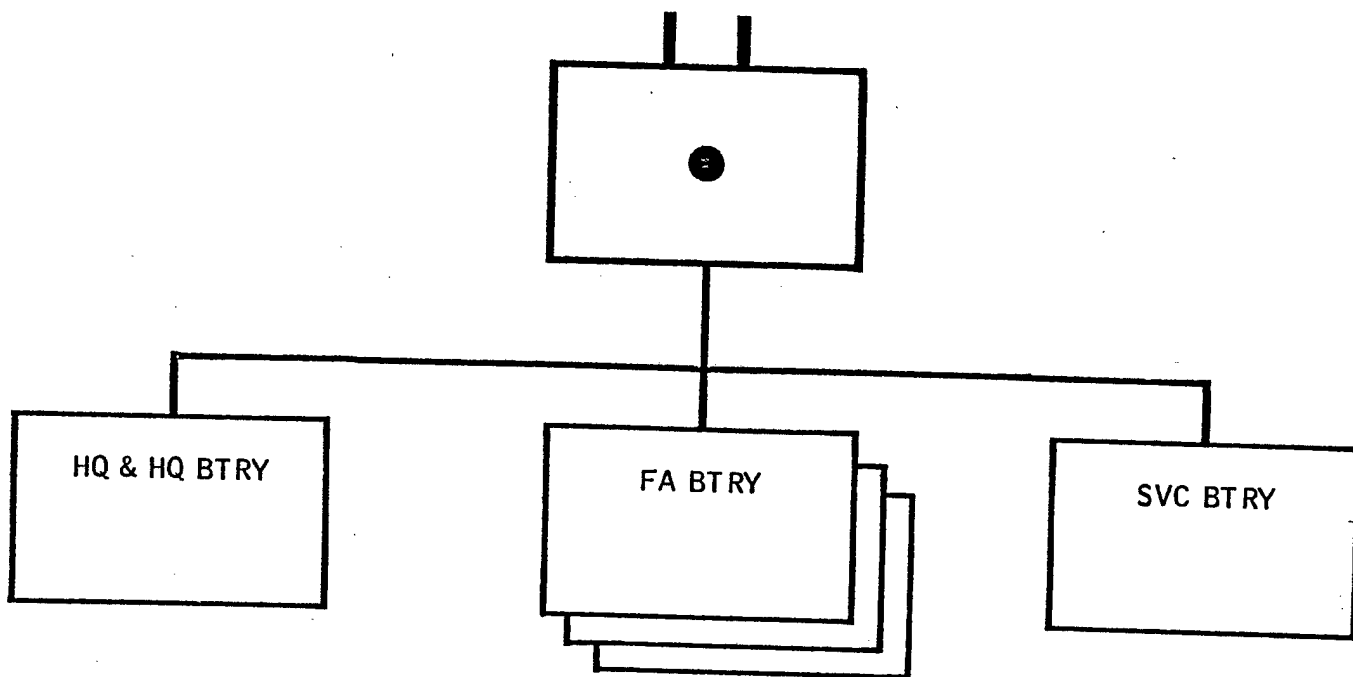
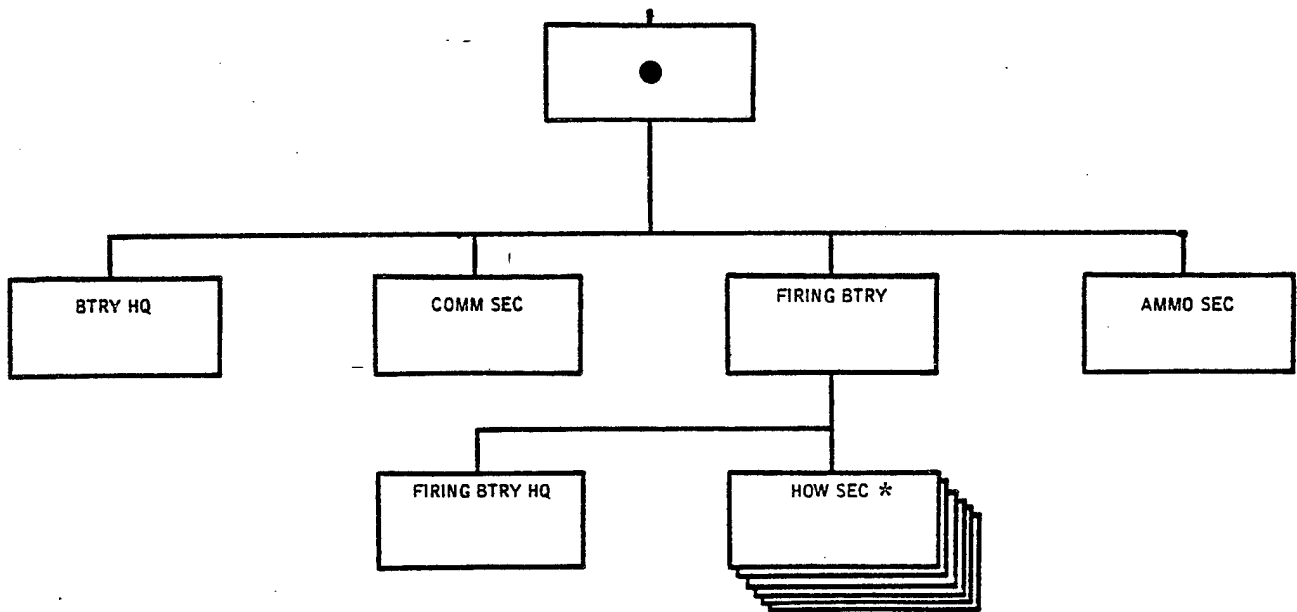

Figure A10. Cannon Artillery Battalion



\*8-inch howitzer and 175mm gun batteries have only four sections.

Figure A11. Cannon Artillery Battery

APPENDIX B  
TANK GUNNERY TABLES

INTRODUCTION

There are nine tank gunnery tables numbered in Roman numerals and followed by the letters A, B, C, or D. The meanings of these letters are:

- A - day firing
- B - night firing
- C - subcaliber firing, day and night
- D - dry firing, ammunition not used

Tables I-V section, and platoon firing skills when main gunfiring at major range complexes is not possible.

Tables VI-IX are full-scale tables.

TANK GUNNERY TABLES

Table I is subcaliber and gives the gunner practice in engaging stationary targets from a stationary tank. Table I has two parts--first zeroing the subcaliber device (machine gun or laser) being used and then manipulation and range card exercises.

Table II is subcaliber and teaches the gunner and tank commander the fundamentals of fire adjustment.

Table III is subcaliber and teaches crewmen to track, lead, and engage a moving variable speed target and to adjust fire properly in the event of a first round miss.

Table IV is subcaliber and is the first permitting the tank crew to train as a team. It teaches the crew to engage, from a stationary tank, scaled stationary and moving targets placed in a tactical array.

Table V is subcaliber and teaches the crew to engage, from a moving tank, stationary main gun targets placed in a tactical array.

Table VP is subcaliber and teaches the section and platoon to engage, while outnumbered, stationary and moving main gun targets placed in tactical array.

Table VI is the first table permitting the crew to fire the main gun. This table teaches conduct of tank fire using battle sight and precision main gun engagement techniques, and machinegun engagement techniques on stationary and moving targets. In this table, the tank is stationary.

Tables VII and VIII are the crew combat course. Table VII is preparatory firing and Table VIII is qualification firing. The tables are conducted over courses providing as much of the realism of cross-country firing as safety will permit. Table VII teaches the crew to engage moving and stationary targets with all tank-mounted weapons during daylight and periods of limited visibility.

Table IX is the platoon battle run and incorporates tank fire with tactical maneuver. It teaches and tests control and distribution of platoon fires.

#### SEQUENCE OF FIRING

As a normal rule, the sequence in training for a given table is:

- Dry firing (except Tables I, II, and III)
- Subcaliber firing
- Day live firing
- Night live firing

The usual sequence for firing the various gunnery tables is given below.

Table I  
Table II  
Table III  
Table IV  
Table V  
Table VI  
Table VIIC  
Table VII  
Table VIII  
Table VP  
Table IX

APPENDIX C  
SUGGESTED COMMENT FORM

A suggested comment form for use by respondents in the recommended informal review follows. This form was successfully used in the limited informal reviews that were conducted.

The form was developed to minimize writing on the part of the respondents and still obtain the essential comments. It also provides an opportunity for respondents to expand on the subjects covered if they care to do so.

Unit: \_\_\_\_\_ (USAR) (ARNG) Telephone: \_\_\_\_\_

Address: \_\_\_\_\_  
\_\_\_\_\_

CORE TRAINING TASKS CONCEPT  
COMMENT SHEET

1. GENERAL

a. Is the concept of core training tasks for RC units, as described in Section 2 of the attached report, satisfactory to you?

\_\_\_\_ Yes \_\_\_\_\_ No

b. If the concept is not satisfactory to you, please state your major objections.

(1) \_\_\_\_\_  
\_\_\_\_\_

(2) \_\_\_\_\_  
\_\_\_\_\_

(3) \_\_\_\_\_  
\_\_\_\_\_

c. Do you have any alternatives to core tasking? If so, please describe.

\_\_\_\_\_  
\_\_\_\_\_  
\_\_\_\_\_

2. CORE TRAINING TASKS

NOTE: Circle the type of battalion addressed.

tank    mechanized infantry    infantry    artillery

a. Do you believe that some of the identified core training tasks are not truly core tasks?

\_\_\_\_ Yes \_\_\_\_\_ No

b. If you checked "Yes," please list the training tasks that you believe are not truly core tasks.

\_\_\_\_\_  
\_\_\_\_\_  
\_\_\_\_\_  
\_\_\_\_\_

c. Do you believe that there are additional training tasks that could be identified as core tasks?

Yes  No

d. If you have checked "Yes," please list the training tasks that you believe should be identified as core tasks.

---

---

---

---

e. Do you believe that the core training tasks listed for peacetime accomplishment are achievable assuming (1) no change in the current 48 UTAs and 2 weeks AT per year and (2) the battalion is at least 70% in strength?

Yes  No

f. If you checked "No," please list those core training tasks that should be shifted to postmobilization accomplishment.

---

---

---

---

g. Do you believe that any of the core training tasks, listed for postmobilization accomplishment, could be accomplished during peacetime in addition to those already listed for accomplishment in peacetime?

Yes  No

h. If you checked "Yes," please list those that should be shifted to peacetime accomplishment.

---

---

---

---

---

i. Do you believe that the estimate of the training time for each postmobilization core task is reasonable?

Yes

No

If you checked "No," please give your estimate.

---

---

---

3. GENERAL COMMENTS

a. The space below is for any general comments and observations pertaining to the core training task concept that you may care to make.

---

---

---

---

---

---

---

---

---

---

---

---

(Rank and Name)

---

(Position Assignment)