



---

---

**A PERFORMANCE AND COST  
EVALUATION OF ULTROX D-TOX™  
UV/OXIDATION SYSTEM FOR  
THE TREATMENT OF HYDROCARBON VAPORS  
FROM FUEL-CONTAMINATED SOILS**

**DRAFT**

**JULY 1996**

**Distribution is unlimited; approved for public release**

**AIR FORCE CENTER FOR ENVIRONMENTAL EXCELLENCE (AFCEE)  
TECHNOLOGY TRANSFER DIVISION**

**19970424 044**

**DTIC QUALITY INSPECTED 3**

**A PERFORMANCE AND COST  
EVALUATION OF ULTROX D-TOX™  
UV/OXIDATION FOR TREATMENT OF  
HYDROCARBON VAPORS FROM FUEL-CONTAMINATED SOILS**

**DRAFT**

by

**Steven R. Archabal, Douglas C. Downey, and Donald R. Malone**

**PARSONS ENGINEERING SCIENCE, INC.  
DENVER, COLORADO**

For

**U.S. AIR FORCE  
CENTER FOR ENVIRONMENTAL EXCELLENCE  
BROOKS AIR FORCE BASE, TEXAS**

*This document was prepared for the United States Government by Parsons Engineering Science, Inc. In no event shall either the United States Government or Parsons Engineering-Science, Inc. have any responsibility or liability for any consequences of any use, misuse, inability to use, or reliance upon the information contained herein, nor does either warrant or otherwise represent in any way the accuracy, adequacy, or applicability of the contents hereof.*

## TABLE OF CONTENTS

	Page
PREFACE.....	1
1.0 INTRODUCTION.....	2
1.1 Project Description .....	2
1.2 Site Background.....	2
1.3 Test Objectives.....	2
2.0 PILOT TEST DESIGN.....	5
2.1 Ultrox D-TOX™ Pilot Test System Description.....	5
2.2 Monitoring System Performance .....	7
2.3 Test Conditions .....	9
3.0 PILOT TEST RESULTS.....	9
3.1 Test Results For Varying Flow And Concentration Combinations.....	9
3.2 TVH Destruction Efficiency Relative to Ozone Ratio.....	9
3.3 Extended 30-Day Reliability Test Results.....	10
3.4 Reliability/Maintainability Results .....	15
3.5 Quality Assurance/Quality Control .....	15
4.0 COST AND PERFORMANCE SUMMARY .....	15
4.1 Cost Comparison .....	16
4.2 Estimated Full-Scale Costs .....	16
5.0 CONCLUSIONS AND RECOMMENDATIONS.....	16
5.1 Technology Performance .....	16
5.2 Recommendations .....	19
6.0 REFERENCES .....	20

### LIST OF TABLES

No.	Title	Page
2.1	Laboratory Sampling and Analysis Summary .....	7
2.2	Sampling Field Parameters.....	8
3.1	Summary of Short-Term Results .....	10
3.2	Summary of Extended 30-Day Operation.....	13
3.3	Summary of Effluent Ozone Concentration .....	13
4.1	Summary of Cost Comparison Analysis .....	17

### LIST OF FIGURES

No.	Title	Page
1.1	Site Location Map Pilot Test Demonstration Ultrox UV/Oxidation D-TOX™ Treatment System .....	3
1.2	Ultrox D-TOX™ Pilot Test Demonstration Site Layout .....	4
2.1	Ultrox D-TOX™ Pilot Test System Flow Schematic.....	6
3.1	Summary of TVH Removal Efficiency (30 scfm) .....	11
3.2	TVH Removal Efficiency as a function of Mass Ratio of Ozone to TVH in the Influent Stream (15 scfm) .....	12
3.3	TVH Removal Efficiency as a Function of Mass Ratio Ozone to TVH in the Influent Stream (30 scfm).....	12
3.4	Long-Term Reliability Test TVH Removal Efficiency Over Time.....	14

## **PREFACE**

Parsons Engineering Science, Inc. (Parsons ES) was contracted by the Air Force Center for Environmental Excellence (AFCEE) Technology Transfer Division (ERT) to perform a technology demonstration at Myrtle Beach Air Force Base (AFB), Myrtle Beach, South Carolina. The work was performed for AFCEE/ERT under Contract Number F41624-92-D-8036, Delivery Order 17.

**Key AFCEE/ERT personnel:**

Marty M. Faile - Project Manager

**Key Parsons ES personnel:**

Steven R. Archabal - Site Manager

Donald Malone - Field Engineer

Douglas C. Downey - Technical Director

## 1.0 INTRODUCTION

### 1.1 Project Description

This technology demonstration was completed to determine the feasibility of using an ultraviolet (UV) oxidizing catalyst in the presence of ozone to treat non-chlorinated, fuel hydrocarbon volatile organic compounds (VOCs). The soil vapor extraction (SVE) and treatment demonstration was conducted at the Installation Restoration Program (IRP) Site SS-20 located at Myrtle Beach Air Force Base (AFB), Myrtle Beach, South Carolina. Site SS-20, locally known as the MOGAS site, was previously investigated under the IRP and known to be contaminated with gasoline residuals.

This demonstration was conducted from 10 November to 20 December 1996 and was performed as part of an ongoing innovative technologies evaluation program sponsored by the Air Force in order to promote cost-effective vapor treatment technologies at contaminated sites. The technology demonstration was performed in accordance with the *"Treatability Study Test Design for ULTROX® UV/Oxidation System Pilot Scale Treatability Testing at Myrtle Beach AFB, Myrtle Beach, SC."* (Zimpro, ULTROX Division, September, 1995) as approved by the Air Force and regulatory agencies.

### 1.2 Site Background

The MOGAS site is located at the former motor pool area in the southwest portion of Myrtle Beach AFB (Figure 1.1). Based on several site remedial investigations conducted from 1988 to 1995, subsurface soil and groundwater contamination was found to exist within and surrounding the underground fuel storage tank (UST) areas of the site. Both gasoline and diesel fuel were formerly stored onsite in USTs, although gasoline appears to be the primary contaminant. Figure 1.2 shows the pilot test site layout including the two vent wells and numerous soil vapor monitoring points which were installed to monitor soil vapor extraction and a future bioventing system.

Soil and groundwater contamination detected at the site was primarily VOCs. The primary contaminants of concern at the site are benzene, toluene, ethylbenzene, and xylene (BTEX), and trimethylbenzene isomers. Soils at this site are predominantly fine sand and soil contamination generally extends from a depth of 5 feet to the groundwater which is found at 10-11 feet below ground surface. Two SVE wells completed in contaminated soils were installed at this site to provide a source of VOCs for this demonstration and for future use in a full-scale bioventing system.

### 1.3 Test Objectives

The Ultrox D-TOX™ treatment system was operated at a number of test conditions in order to determine the applicability, performance and cost of using this system to treat fuel hydrocarbon vapors.

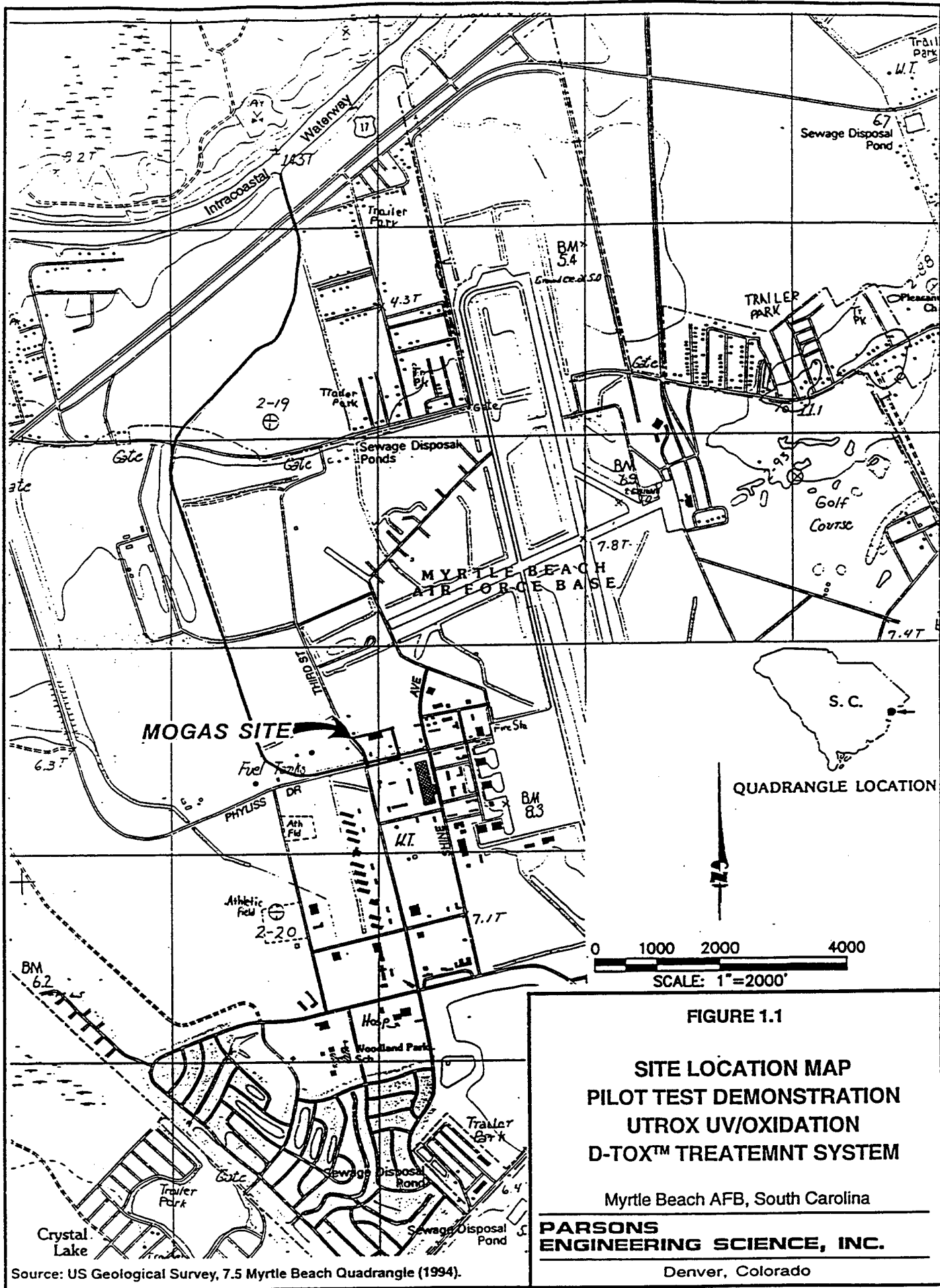

Source: US Geological Survey, 7.5 Myrtle Beach Quadrangle (1994).

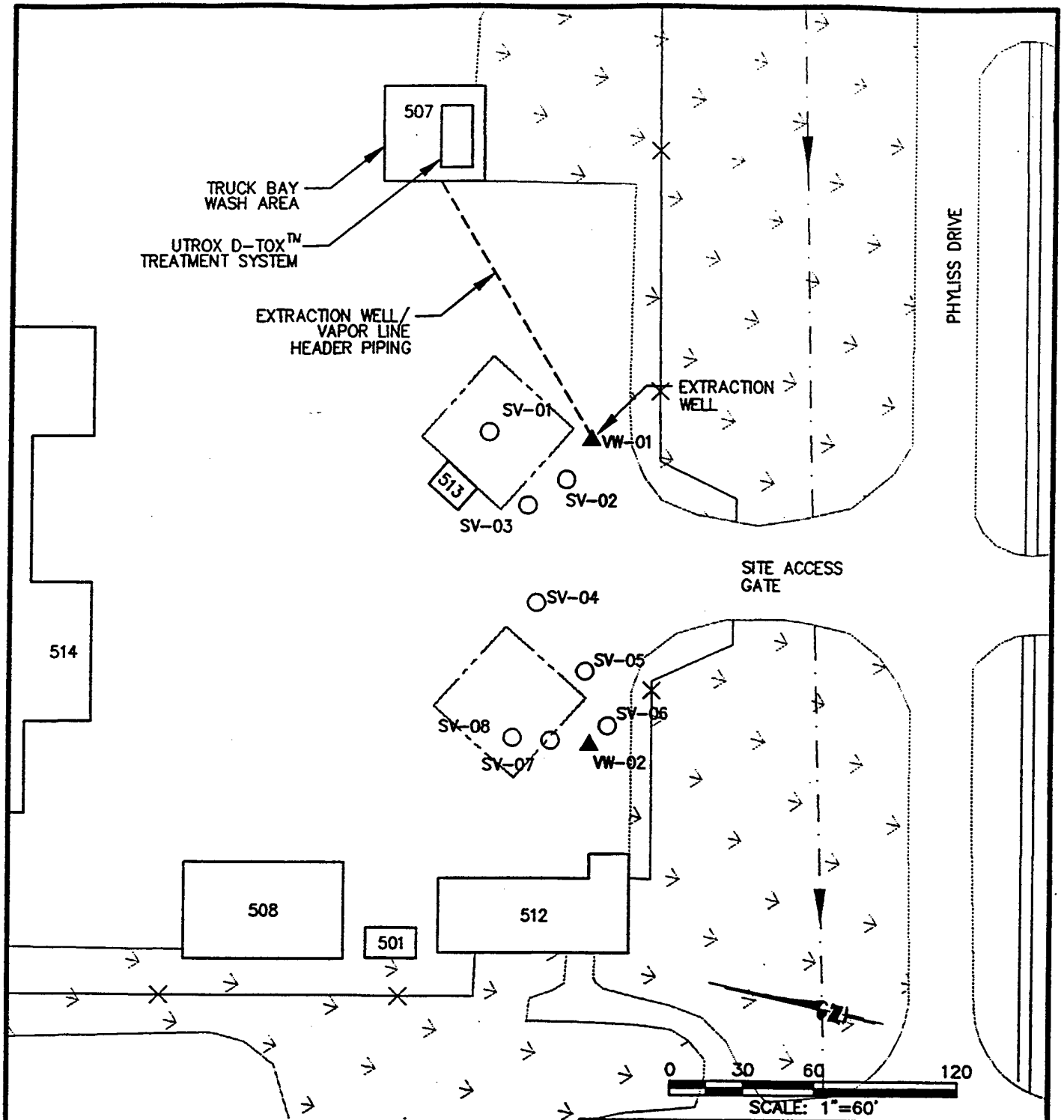

**LEGEND**

- ← ——— DRAINAGE DITCH WITH FLOW ARROW
- × ——— FENCE
- ——— FORMER UST LOCATION
- ▲ SOIL VAPOR EXTRACTION (SVE) VENT WELL
- SOIL VAPOR (SV) MONITORING POINT

**FIGURE 1.2**

**UTRUX D-TOX™  
PILOT TEST DEMONSTRATION  
SITE LAYOUT**

Myrtle Beach AFB, South Carolina

**PARSONS  
ENGINEERING SCIENCE, INC.**

Denver, Colorado

The primary test objectives included:

- Evaluating the system's VOC destruction efficiency under varying flow rates and contaminant concentration (loading rates);
- Evaluating the catalyst efficiency and reliability over a 30-day period using a more uniform loading conditions.
- Developing a cost for scaling the pilot test system to a full-scale treatment system;
- Compliance with South Carolina Department of Health and Environmental Control (SCDHEC) emission standards using Standard No. 8, Air Toxics Levels, and 0.10 ppm for ozone.
- Evaluating the overall applicability of the Ultrox D-TOX™ treatment system for the destruction of fuel-related VOCs.

## 2.0 PILOT TEST DESIGN

### 2.1 Ultrox D-TOX™ Pilot Test System Description

The D-TOX™ treatment system destroys VOCs by exposing the vapor stream to an oxidizing catalyst in the presence of ozone. The oxidation process converts the fuel hydrocarbon vapors to carbon dioxide and water. A second catalyst decomposes any residual ozone in the vapor stream back to oxygen. The pilot test system was designed to extract and treat up to 50 standard cubic feet per minute (scfm) of soil vapor. According to Ultrox, various flow rate and vapor concentration combinations could be treated by this unit although a maximum VOC loading rate of 12.3 kilograms (27 pounds) per day was recommended for optimum treatment efficiency

A process flow schematic for the pilot system is shown in Figure 2.1. The process flow consisted of extracting VOCs from the subsurface soils through an extraction well located within the source area of fuel contamination. The vapors are drawn (under vacuum) through PVC piping to an air/water moisture separator (knockout drum) on the inlet side of the system. The vapor stream remains under vacuum throughout the treatment process, with the vacuum blower installed after the D-TOX™ reactor catalysts and ozone decomposer.

After the vapor stream exits the knockout drum, the inlet flow rate and concentration are manually adjusted by adding dilution air (ambient) to maintain each test condition. The vapors next enter a heat exchanger and preheater #1 that elevate the vapor temperature to between 100 and 125 degrees Fahrenheit (°F) prior to entering the D-TOX™ reactor catalysts. At the inlet of the first D-TOX™ Reactor, ozone is introduced to the vapor stream at a 2 percent by volume concentration, and at a constant flow rate of 520 standard cubic feet per hour (scfh).

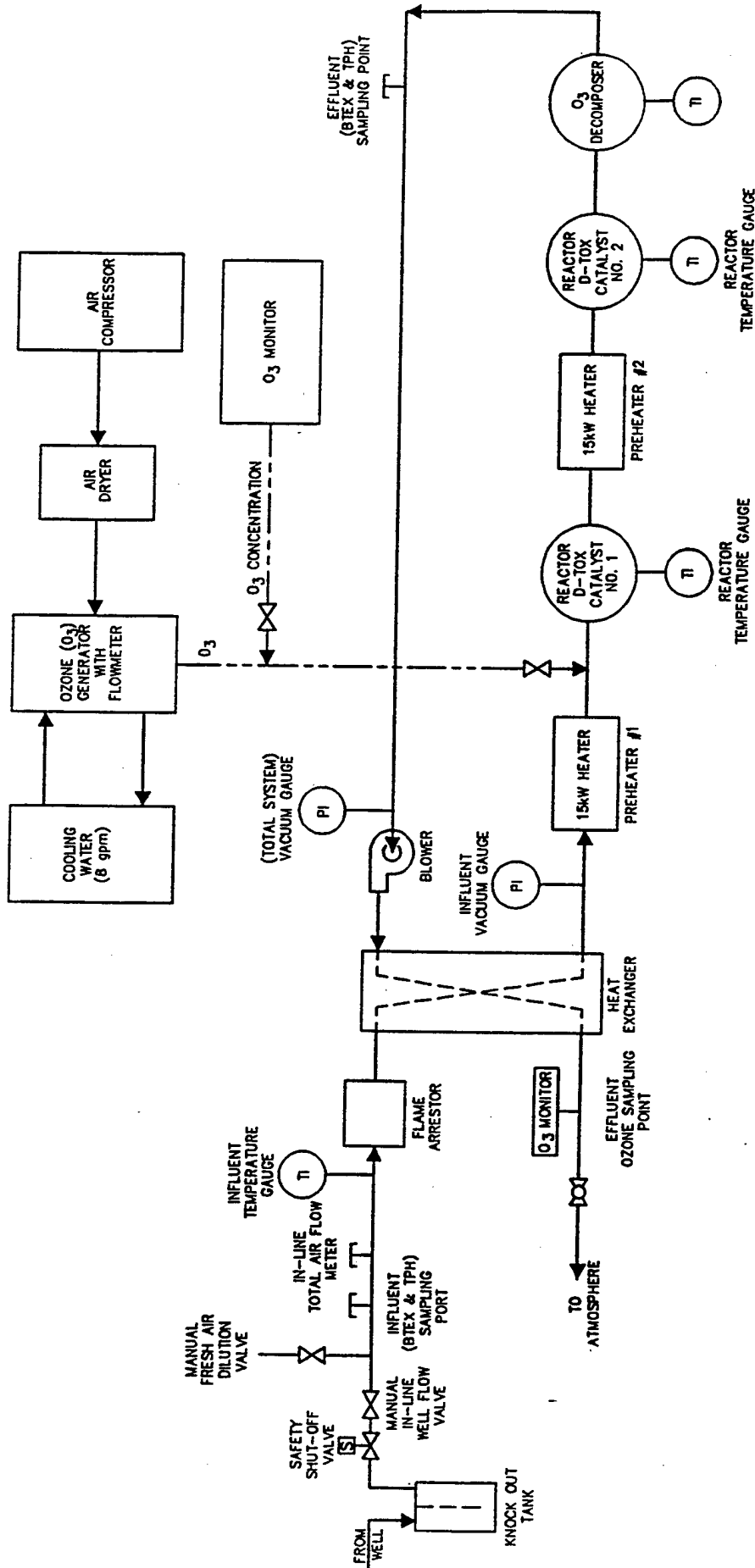

FIGURE 2.1

**UTROX D-TOX™  
PILOT TEST SYSTEM  
FLOW SCHEMATIC 1/**

D-TOX™ VOC Pilot Treatment System  
Myrtle Beach AFB  
Myrtle Beach, South Carolina

**PARSONS  
ENGINEERING SCIENCE, INC.**

Denver, Colorado

1/ FLOW SCHEMATIC FOR A 30 STANDARD CUBIC FEET PER MINUTE (SCFM) VOC TREATMENT SYSTEM EVALUATED AT MYRTLE BEACH AIR FORCE BASE.

The vapor/ozone mixture then enters the D-TOX™ reactor #1 where the initial oxidation takes place at a reactor temperature averaging 230°F. The vapor/ozone mixture then exits reactor #1 and enters preheater #2 which is maintained at a temperature of 215° to 220°F. The partially treated vapors then enters reactor #2 where additional oxidation occurs at a temperature averaging 250°F. Following reactor #2, the vapor stream enters an ozone (O<sub>3</sub>) decomposer that removes any residual ozone in the vapor stream before exiting to the atmosphere. Continuous ozone sampling was performed on the effluent vapor stream to ensure that the removal of residual ozone was sufficient to comply with SCDHEC emission standards.

Utility requirements required to operate the Ultrox D-TOX™ system included 480-volt, 3-phase power and a water source (8 gallons per minute was required for the pilot test system) needed for cooling the ozone generator.

The pilot test system was equipped with vapor sampling ports for the collection of inlet and outlet vapor samples. Flow meters, vacuum gauges, and temperature gauges were also provided to monitor the system's operating parameters (see Figure 2.1.) No formal permit was required for this pilot test, however written permission was provided by the SCDHEC Air Division. Pilot testing was approved by SCDHEC on the conditions that the worst case emissions would not exceed the maximum allowable ambient concentrations (MAACs) required under Standard No. 8, Level II analysis. Table A.1 in Appendix A shows that emissions during the extended testing (11/21/95 - 12/19/95) never exceeded the MAAC de minimis lb/day limit for any compound, including benzene at 0.720 lb/day. The maximum benzene emission observed during the extended testing was 0.32 lb/day, based on system sampling conducted on 11/30/95.

## 2.2 Monitoring System Performance

During the system's performance evaluation, multiple field instruments were used and laboratory samples collected to evaluate the system's destruction efficiency under varying loading conditions. Tables 2.1 and 2.2 summarize the sampling location, analytical method, sampling rationale and frequency.

**TABLE 2.1  
LABORATORY SAMPLING AND ANALYSIS SUMMARY**

Sample Location	Analyte(s) (Analytical Method)	Sampling Rationale	Sample Frequency
System Influent	BTEX and TPH (EPA Method TO-3)	<ul style="list-style-type: none"> <li>• Verify influent VOC concentrations</li> <li>• Calculate total VOC load to system</li> <li>• Calculate system destruction efficiency</li> </ul>	<ul style="list-style-type: none"> <li>• Initial 5 days: 10 sampling events; once at every new test condition</li> <li>• Then weekly: for weeks 2-5, (total 4 sampling events)</li> </ul>
System Effluent	BTEX and TPH (EPA Method TO-3)	<ul style="list-style-type: none"> <li>• Verify Effluent VOC concentrations</li> <li>• Calculate system destruction efficiency</li> <li>• Determine air emissions</li> </ul>	<ul style="list-style-type: none"> <li>• Same as system influent</li> </ul>

**TABLE 2.2  
SAMPLING FIELD PARAMETERS**

Sample Location	System Parameter	Sampling Rationale	Sample Method
Influent and Effluent	Pressure/Vacuum	<ul style="list-style-type: none"> <li>Determine pressure drop across the system</li> </ul>	<ul style="list-style-type: none"> <li>Vacuum gauges (magnetic)</li> </ul>
	Temperature (°F <sup>a/</sup> )	<ul style="list-style-type: none"> <li>Maintain operating temperatures in all reactors</li> </ul>	<ul style="list-style-type: none"> <li>Temperature gauges (Ashcroft-Bi-Metal mechanical dial)</li> </ul>
	Total VOC <sup>b/</sup> concentration	<ul style="list-style-type: none"> <li>Collect onsite VOC concentrations to maintain steady-state condition</li> </ul>	<ul style="list-style-type: none"> <li>Direct reading-handheld instrument (GasTech Trace-Techtor hydrocarbon analyzer)</li> </ul>
Influent	Vapor flow rate	<ul style="list-style-type: none"> <li>Calculate VOC loading rate</li> </ul>	<ul style="list-style-type: none"> <li>Kurz-Thermal Mass Flow Meter (scfm<sup>c/</sup>)</li> </ul>
Influent to DTOX Reactor #1	Ozone (O <sub>3</sub> ) flow rate	<ul style="list-style-type: none"> <li>Calculate O<sub>3</sub> loading rate</li> </ul>	<ul style="list-style-type: none"> <li>Dwyer Rotometer (scfh<sup>d/</sup>)</li> </ul>
	Concentration (percent)	<ul style="list-style-type: none"> <li>Calculate O<sub>3</sub> loading rate</li> </ul>	<ul style="list-style-type: none"> <li>PCI Ozone Monitor (range 0 to 10% by weight)</li> </ul>
Effluent	Ozone-concentration (parts per million volume per volume - [ppmv])	<ul style="list-style-type: none"> <li>Determine O<sub>3</sub> removal efficiency</li> <li>Health and safety sampling to ensure personnel were not overexposed</li> </ul>	<ul style="list-style-type: none"> <li>PCI Ozone Monitor (ppmv)</li> </ul>

a/ Degrees Fahrenheit

b/ Volatile Organic Compounds

c/ Standard Cubic Feet per Minute

d/ Standard Cubic Feet per Hour

Initially, two vapor samples were collected prior to the system evaluation. The purpose of these samples were to establish a correlation between the GasTech instrument and the laboratory results for the same sample. Vapor samples were collected at two different ranges, one in the lower and one in the upper range of the test conditions being evaluated. The handheld readings obtained during the calibration/correlation sampling were 900 and 3,000 ppmv using the GasTech, Trace-Techtor™ hydrocarbon analyzer, and the laboratory results were 600 and 2,500 ppmv, respectively. Therefore, a response factor (RF) of 1.5 was used for test conditions below 1,000 ppmv and RF of 1.2 was used for test conditions above 1,000 ppmv. To use the RF, the direct reading instrument concentration was divided by the RF in order to more closely reflect what the result would be from the laboratory. By using the

established RFs, target concentrations could be adjusted using real time VOC monitoring data. The GasTech Trace-Techtor™ portable gas analyzer was selected for real time, field monitoring of the system. This device uses a platinum catalyst detector and has been a very reliable instrument in the 100-5,000 ppmv range for fuel hydrocarbon vapors. The Trace-Techtor™ instrument was calibrated prior to each sampling event using a 3,300 ppmv hexane calibration standard.

Upon reaching each test condition, the system was allowed to stabilize for approximately 2 hours prior to the collection of influent and effluent laboratory samples. This time was necessary to allow the reactor temperatures and pressure/vacuum fluctuations within the system to equilibrate.

### **2.3 Test Conditions**

The pilot system was tested at 15 and 30 scfm flow rates, and at VOC influent target concentrations of 200, 800, 1,500, 3,000, and 5,000 ppmv.

## **3.0 PILOT TEST RESULTS**

### **3.1 Test Results For Varying Flow And Concentration Combinations**

The laboratory analytical results from first phase of the D-TOX™ pilot test are summarized in this section. Table 3.1 provides the data collected during the short-term testing period that focused on the system's destruction efficiency at varying flow rates and concentrations.

Influent concentrations for total volatile hydrocarbons (TVH) ranged from 180 to 6,000 ppmv during the short-term testing period. During the extended period, influent TVH concentrations ranged from 1,100 to 1,600 ppmv. The ozone influent loading rate remained constant throughout the test at approximately 28 pounds per day.

TVH destruction efficiencies for the D-TOX™ system ranged from 71 to 99 percent during the short-term tests. Benzene destruction efficiency also ranged from 70 to 99.9 percent. Based on these results, the pilot unit was able to achieve TVH destruction efficiencies of greater than 90 percent only when TVH loading rates were less than 8 kilograms (18 pounds) per day. Figure 3.1 shows the removal efficiency when compared to loading rate while operating at 30 scfm.

### **3.2 TVH Destruction Efficiency Relative to Ozone Ratio**

Another test objective was to determine the impact of the ozone to TVH ratio on the percent TVH removed from the vapor stream. The optimum loading ratio of ozone to TVH was desired to achieve the maximum TVH destruction efficiency.

Figures 3.2 and 3.3 illustrates the effect of the ozone to TVH ratio relative to destruction efficiency during the short-term tests at both 15 and 30 scfm. Based on this test, a ozone to TVH ratio of approximately 2:1 was selected for the extended test period.

**TABLE 3.1**  
**SUMMARY OF SHORT-TERM RESULTS**

<b>Laboratory TVH Results</b>			
Influent Flow Rate (scfm)	Influent (ppmv)	Effluent (ppmv)	Destruction Efficiency (percent)
15	180	4.1	97.7
15	1,000	22	97.8
15	1,600	53	96.7
15	2,700	310	88.5
15	5,800	860	85.2
30	280	3	99.0
30	1,100	17	98.4
30	1,600	150	90.6
30	2,900	480	83.4
30	6,000	1,700	71.7

### 3.3 Extended 30-Day Reliability Test Results

To further evaluate the long-term reliability of the D-TOX™ system for the treatment of VOCs, an extended 30-day reliability test was performed immediately following the short-term testing period.

During the extended test period, flow rate and concentration remained relatively constant and the focus was on long-term performance and equipment reliability (i.e., D-TOX™ reactor catalyst life expectancy). During this period, the influent vapor stream was maintained at an average influent concentration of 1,300 ppmv, a flow rate of 30 scfm, and an optimum ozone ratio of 2 pounds ozone to 1 pound TVH (2:1). By maintaining a relatively constant ozone ratio over the extended test period, any decline in removal efficiency can be attributed to a contaminated or degraded D-TOX™ reactor catalyst.

Table 3.2 and Figure 3.4 provide data on the reduction in TVH destruction efficiency over the extended test period. While the system parameters (flow/concentration) remained relatively constant, the removal efficiency significantly declined over the 30 days of extended pilot testing. During this period, TVH removal efficiency decreased from 83 to 62 percent. Table A.1 in Appendix A provides a summary of all the sampling performed during the test, as well as removal efficiencies and ozone ratios at the varying test conditions.

In addition, a slight increase in the effluent ozone concentration was observed in the readings collected by the continuous onsite monitoring instrumentation. Table 3.3 provides the daily effluent ozone concentrations during the pilot test period. The maximum effluent concentration allowed during this test was 0.10 ppm. Although this

**FIGURE 3.1**  
**SUMMARY OF TVH REMOVAL EFFICIENCY**  
**(30 scfm)**

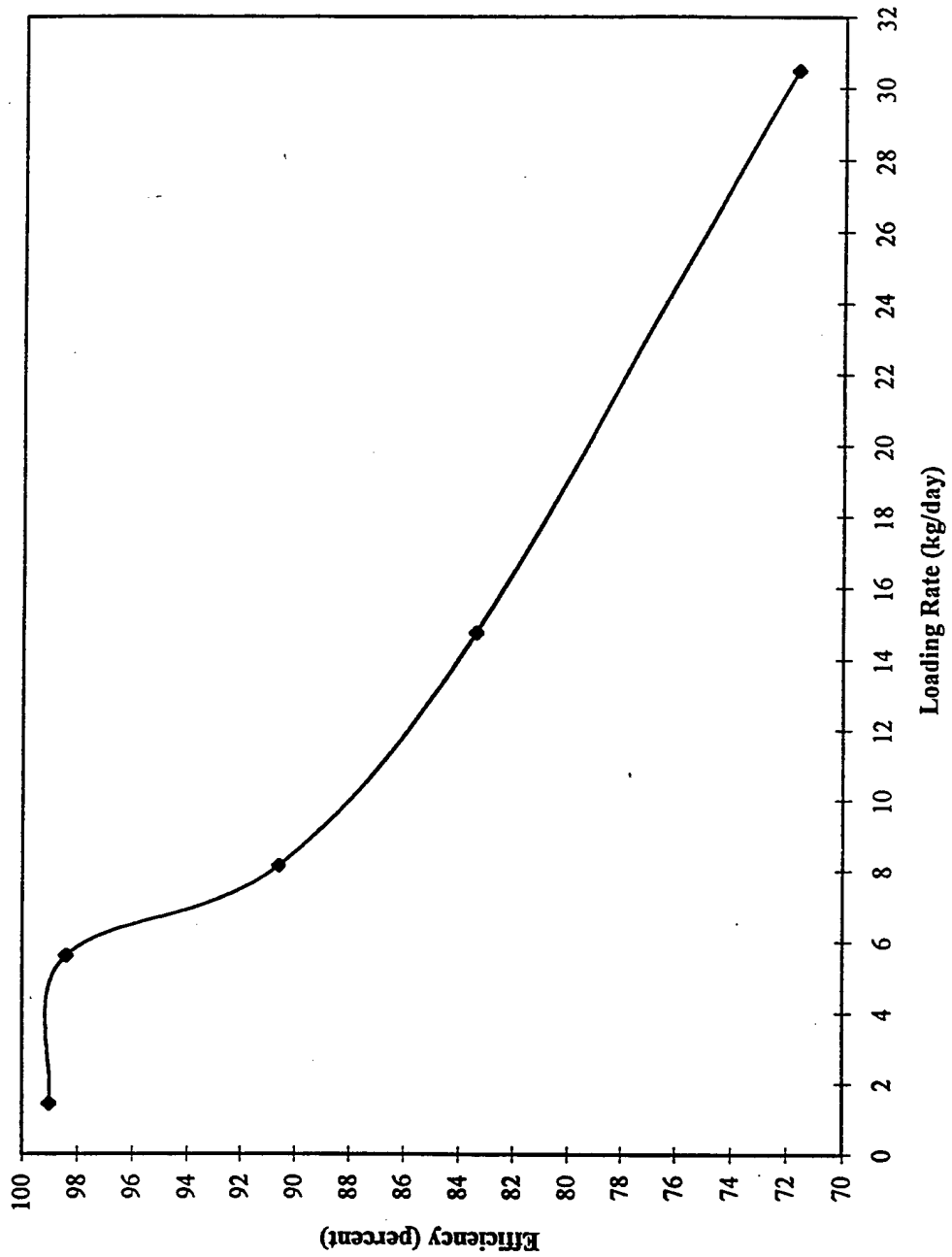

**FIGURE 3.2**  
**TVH REMOVAL EFFICIENCY AS A FUNCTION OF**  
**MASS RATIO OF OZONE TO TVH IN THE INFLUENT**  
**STREAM (15 scfm)**

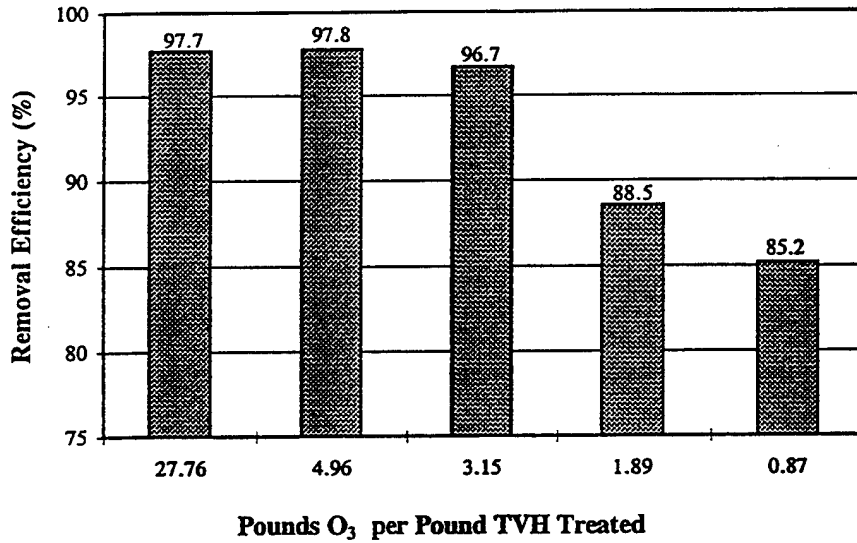

**FIGURE 3.3**  
**TVH REMOVAL EFFICIENCY AS A FUNCTION OF**  
**MASS RATIO OF OZONE TO TVH IN THE INFLUENT**  
**STREAM (30 scfm)**

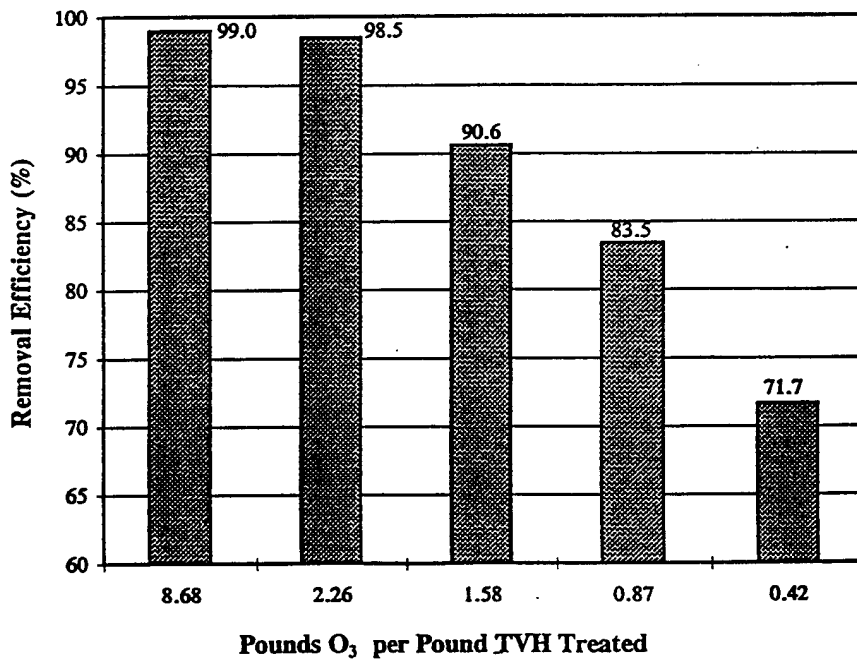

**TABLE 3.2**  
**SUMMARY OF EXTENDED 30-DAY OPERATION**

<b>Laboratory TVH Results</b>			
Influent Flow Rate (scfm)	Influent (ppmv)	Effluent (ppmv)	Destruction Efficiency (percent removed)
30	1,100	210	80.9
30	1,600	270	83.1
30	1,300	350	73.1
30	1,100	420	61.8

**TABLE 3.3**  
**SUMMARY OF EFFLUENT OZONE CONCENTRATION**

Day	Ozone Concentration (ppmv)
1-9	0.0
10	0.007
11	0.043
12	0.077
13	0.017
14	0.003
15	0.018
16	0.010
17	0.010
18	0.055
19	0.041
20	0.072
21	—
22	0.02
23	0.053
24	0.045
25	0.045
26	0.04
27	0.056
28	0.085
29	0.033
30	0.03

**FIGURE 3.4**  
**LONG-TERM RELIABILITY TEST**  
**TVH REMOVAL EFFICIENCY OVER TIME**

(average influent concentration = 1,300 ppm; flowrate = 30 scfm; ozone/TVH ratio = 2/1)

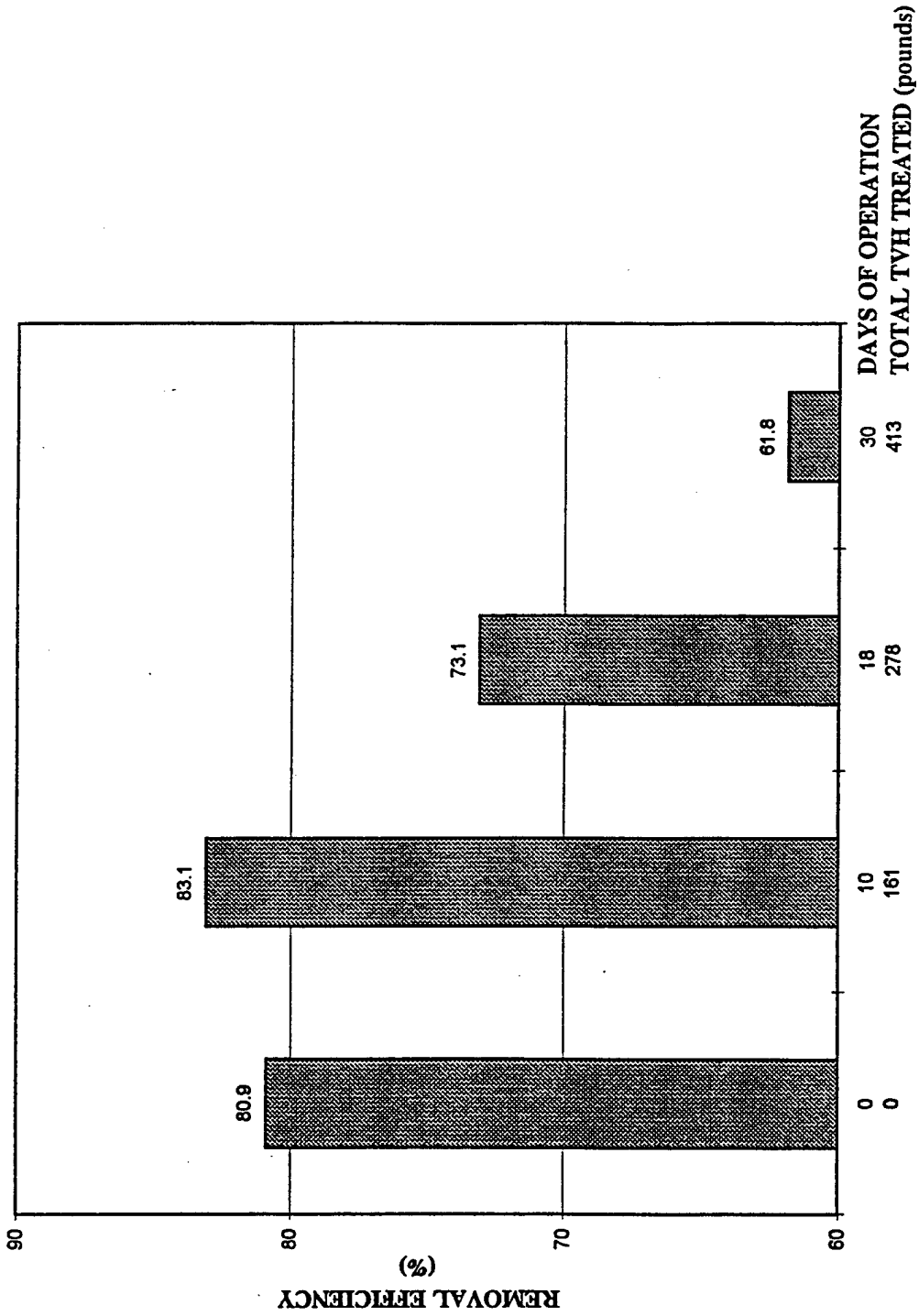

limit was never exceeded during the pilot test, some decrease in the capacity of the ozone decomposer catalyst to remove residual ozone was observed.

### **3.4 Reliability/Maintainability Results**

- **Downtime**
- 1-Day (3%) downtime due to vacuum blower failure and high reactor temperatures during 30-day test.
- 7-Hours downtime due to cooling water leak in ozone generator during short term testing.
- **Maintenance**
- At least 1 to 2 hours of onsite time was required each day to make manual adjustments to the system.
- Due to significant reductions in destruction efficiency in the D-TOX™ reactor catalysts and ozone decomposer, frequent replacement of these components would be necessary (possibly every 3 to 6 months). This is based on the reduction in efficiency observed during the pilot test.
- **Operation Considerations**
- The system tested was completely manually operated, including flow rates and temperature. This would require more onsite time than a system with remote/automated capabilities.

### **3.5 Quality Assurance/Quality Control**

The primary objective of the QA/QC program is to ensure that the sampling procedures and data obtained during the course of the project are adequate to determine the feasibility of using the D-TOX™ treatment system for the treatment of extracted soil vapor containing VOCs under a variety of conditions, and to ensure compliance with applicable environmental regulations during the project.

All Method TO-3 analyses were performed within the holding times recommended for the specific test procedure and sample matrix. Samples were collected and shipped in EPA-recommended sample containers (e.g., Summa® canisters) to an analytical laboratory specializing in air analysis.

### **4.0 COST AND PERFORMANCE SUMMARY**

As part of the Ultrox D-TOX™ system evaluation, a full scale cost analysis and cost comparison to other VOC treatment technologies is presented in this section.

## 4.1 Cost Comparison

Table 4.1 presents a performance-based cost analysis of the Ultrox D-TOX™ system. Specifically, Table 4.1 focuses on capital purchase cost and anticipated operations and maintenance (O&M) costs (including supplemental fuel, site optimization time, equipment maintenance/replacement) of the Ultrox D-TOX™ system compared to other fuel hydrocarbon SVE VOC treatment systems. Based on an estimated total daily operating cost, the various technologies are compared to one another on expected optimum destruction efficiency, maximum daily pounds TVH removed at this efficiency, and the cost per pound of TVH removed using each technology. The assumptions used in this comparison are based on data collected from actual pilot test demonstrations at other Air Force sites. In the case of vapor-phase granular activated carbon (GAC), a conservative 20 percent average loading capacity was used. This loading capacity takes into account soil vapor with moderate to high relative humidity (70 to 90 percent), that reduces the efficiency of the adsorption capacity of the carbon. Costs for the V2C ICE unit are based on previous Air Force testing of ICEs (Archabal and Downey, 1994) and manufacturer's data.

## 4.2 Estimated Full-Scale Costs

Because many sites will produce a hydrocarbon extraction rate of greater than 8 kilograms (18 pounds) per day, the cost of a larger D-TOX™ system was also evaluated.

Based on the vendor's supplied pricing schedule (Zimpro, 1996), and using the same assumptions and information provided in Table 4.1, the estimated cost of a 110 scfm ULTROX D-TOX™ system is provided in Table 4.2. No performance or cost on the scaled up Ultrox D-TOX™ system (110 scfm) is available, since no systems of this size have been built.

## 5.0 CONCLUSIONS AND RECOMMENDATIONS

### 5.1 Technology Performance

- A series of short-term tests concluded that the Ultrox D-TOX™ System was capable of achieving TVH destruction efficiencies of greater than 98 percent when the TVH loading rate was less than 4 kg/day. Treatment efficiencies of less than 90 percent were observed when the loading rate exceeded 6 kg/day.
- An ozone to TVH ratio of 2:1 was required to achieve greater than 90 percent destruction efficiency in the 4-6 kg/day loading range.
- During the 30-day extended test, the treatment efficiency decreased from approximately 83 percent to 62 percent at a constant TVH loading of 6.6 kg/day. The performance of the D-TOX™ catalyst appears to degrade over time and is a subject of concern.

**TABLE 4.1  
SUMMARY OF COST COMPARISON ANALYSIS**

Item	Ultrox D-TOX™ Treatment System	Internal Combustion Engine (ICE) VR Systems, Model V2C	Vapor-Phase Granular Activated Carbon (GAC)
• Capital Cost (for 3 years of operation)	\$233,400	\$62,120	GAC cost based on bulk purchase of 2,000 lb canisters @ \$2.13/lb.
Capital Cost Includes:			
Treatment Unit <sup>a/</sup>	\$162,000	\$47,000	
System Spares <sup>b/</sup>	\$54,900 <sup>c/</sup>	\$12,120 <sup>d/</sup>	
Power Hookup	\$1,500 <sup>e/</sup>	NA <sup>f/</sup>	
Initial Setup/Startup	\$15,000 <sup>g/</sup>	\$3,000 <sup>h/</sup>	
<b>TOTAL CAPITAL</b>	<b>\$233,400</b>	<b>\$62,120</b>	
• <u>Monthly Capital</u> <sup>i/</sup>	\$6,483	\$1,725	
• <u>Monthly System Monitoring</u> <sup>j/</sup>	\$1,200	\$1,200	\$1,200 (or \$40/day)
• <u>System Specifications</u>			
- Maximum Flow Rate (scfm)	30	50	Note: Requires Blower to extract soil vapor.
- Expected Destruction			
Efficiency (percent removal)	70% to 80%	99%	
- Maximum Influent Concentration - ppmv <sup>k/</sup> System as Tested (manual or remote capability)	1,500 Manual <sup>l/</sup>	40,000 Remote	1,500 ppm Manual
<b>SUPPLEMENTAL FUEL COSTS</b>	Electric and Water <sup>o/</sup>	Propane <sup>p/</sup>	
@ Constant 30 scfm Flow Rate			
@ Various Loading Rates	<u>Daily</u> <u>Monthly</u>	<u>Daily</u> <u>Monthly</u>	Note: GAC costs based on a 20% loading capacity for carbon
• 500 ppmv, 2.54 kg/day	\$49.14      \$1,474	\$22.12      \$664.00	
• 1,000 ppmv, 5.08 kg/day	\$49.14      \$1,474	\$21.84      \$655.00	
• 1,500 ppmv, 7.62 kg/day <sup>m/</sup>	\$49.14      \$1,474	\$21.58      \$647.00	
• 40,000 ppmv, 203 kg/day <sup>n/</sup>	NA      NA	0      0	
<b>TOTAL MONTHLY COSTS<sup>q/</sup></b>			
@ 2.54 kg/day	\$9,157.00	\$3,589.00	
@ 5.08 kg/day	\$9,157.00	\$3,589.00	
@ 7.62 kg/day	\$9,157.00	\$3,589.00	
@ 203 kg/day	NA	\$2,925.00	
<b>COST PER KILOGRAM TREATED<sup>r/</sup></b>	<u>Base Cost/Day</u> <u>Cost/kg</u>	<u>Base Cost/Day</u> <u>Cost/kg</u>	<u>Base Cost/Day</u> <u>Cost/kg</u>
@ 2.54 kg/day	\$305.23    \$120.17	\$119.60    \$47.09	\$99.50    \$39.17
@ 5.08 kg/day	\$305.23    \$60.08	\$119.30    \$23.48	\$159.00    \$31.30
@ 7.62 kg/day	\$305.23    \$40.06	\$119.07    \$15.63	\$218.50    \$28.67
@ 203 kg/day	NA      NA	\$97.50    \$0.48	\$4,796.00    \$23.62

**ASSUMPTIONS**

- a/ Cost based on a 30 standard cubic foot per minute (scfm) treatment system.
- b/ Cost for system spares (replacement parts) over 3 years of operation.
- c/ Cost based on replacement of both the D-TOX™ and ozone decomposer catalysts every 6 months. (Assumes 24-hours/day operation and labor requiring 2 persons for 2 days @ \$50/hr.)
- d/ Cost based on replacement of the exhaust catalyst (\$120/ea.) every 4,000 engine hours (6 months) and labor for 1 person, 1 day @ \$50/hr. Also, includes monthly engine maintenance (every 720 engine hours) including parts and labor (\$250/mo) for 3 years.

**TABLE 4.1 (Continued)**  
**SUMMARY OF COST COMPARISON ANALYSIS**

- e/ Cost based on only one site with 440-volt, 3-phase power available within 50 feet, and no trenching is required.
- f/ Not applicable.
- g/ Cost based on quote from vendor, that includes: 2 persons for 2 weeks for system installation and startup and freight.
- h/ Cost based on actual field installations that includes: freight (\$1,500) and setup/startup (one person, 3 days).
- i/ Cost based on an amortized capital cost over 36 months.
- j/ Monthly monitoring includes: one person, one day @ \$50/hr and 2 laboratory air analyses (1 influent, 1 effluent).
- k/ Maximum influent concentration in parts per million, volume per volume to assure destruction efficiency.
- l/ System tested required manual adjustments to maintain optimization. Vendor claims that addition of remote capability would cost \$8,000. (Note: This performance evaluation does not support the vendor's claim that the system could have remote capability or that the cost provided is accurate.)
- m/ Maximum influent loading rate in kilograms per day at 30 scfm for the Ultrox D-TOX™ system, to assure stated destruction efficiency (70% to 80%). (Note: At higher loading rates, efficiency decreases.)
- n/ Maximum influent loading rate for the VR System ICE at 30 scfm, to assure 99% destruction efficiency.
- o/ Supplemental electric and water consumption costs for the Ultrox D-TOX™ System. Costs based on utility rates of: Water = \$1.80 per 1,000 gallons (potable) with system requirement of 8 gallons per minute (GPM); and electric = \$0.08 per kilowatt hour, with system requirement of 355 kwh/day.
- p/ Supplemental fuel costs using propane at \$0.80 per gallon for the VR Systems, Model V2C operating at an engine speed of 1,800 RPM.
- q/ Cost based on a 30-day month that includes: total capital purchase amortized over 36 months, system monitoring, supplemental fuel usage, and initial setup/startup.
- r/ Cost based on a 30-day month at various loading rates.

TABLE 4.2

ESTIMATED COSTS FOR 110 SCFM ULTROX D-TOX™ SYSTEM

<u>Item</u>	<u>Cost</u>
Capital (includes initial setup)	\$310,000.00
System Spares (for 3 years of operation)	\$136,500.00
Labor (includes monitoring and system repair for 3 years)	\$60,000.00
Supplemental Fuel Usage (electric [1,300 KWH/day] and water [40 GPM] for 3 years of operation)	\$224,640.00
Estimated 3 Year Total Cost	\$731,140.00
Estimated Daily Operational Cost (Based on 30-day Month)	\$677.00
Estimated daily TVH Removal in Kilograms (Based on; 1,500 ppmv @ 110 scfm)	28 kg/day
Estimated Cost per Kilogram Treated	\$24.00

- The total daily operating cost of the unit during the 30-day extended test was estimated at \$305/day. This equates to a pilot-scale treatment cost of \$46 per kilogram. The full-scale unit cost was estimated at \$24 per kilogram which is comparable to the cost of activated carbon but considerably more than the unit TVH destruction cost for the internal combustion engine technology.
- The system was generally reliable and did not experience excessive down time. However, in its current configuration the D-TOX™ System requires daily monitoring and manual adjustments to maintain an optimum ozone to TVH ratio.

5.2 Recommendations

- Additional testing and improvements are needed to the catalyst system to achieve higher destruction efficiencies and a longer effective operating lifetime.
- The cost of operating the D-TOX™ System must be reduced to give this technology any cost advantage over activated carbon. For low vapor concentrations (<1,000 ppmv) carbon is still the preferred alternative because negligible maintenance costs and because it has no mechanical parts which can break down.

## 6.0 REFERENCES

- Archabal, S.R. and D.C. Downey. 1994. "A Performance and Cost Evaluation of Internal Combustion Engines for the Destruction of Hydrocarbon Vapors from Fuel-Contaminated Soils," prepared for the Air Force Center for Environmental Excellence, Brooks AFB, TX.
- Zimpro, Ultrox Division. 1995. "Treatability Study Test Design for Ultrox® UV/Oxidation System Pilot Scale Treatability Testing at Myrtle Beach AFB, Myrtle Beach, SC," prepared for the Air Force Center for Environmental Excellence, Brooks AFB, TX. September.
- Zimpro, Ultrox Division. 1996. "Technical Report, Ultrox D-TOX™ Volatile Organic Compound Treatment System, Pilot Scale Treatability Testing, Myrtle Beach AFB, Myrtle Beach, SC," prepared for the Air Force Center for Environmental Excellence, Brooks AFB, TX. February.

**APPENDIX A**

**TABLE A.1**  
**SUMMARY OF INFLUENT AND EFFLUENT ANALYTICAL RESULTS/REMOVAL EFFICIENCY/OZONE RATIO**  
**FOR THE ULTROX EVALUATION**  
**MYRTLE BEACH AFB, SOUTH CAROLINA**

GENERAL SAMPLING INFORMATION		TVH RESULTS			BENZENE RESULTS			REMOVAL EFFICIENCY		OZONE RATIO				
		Sample Date	Sample Time	Flow rate (scfm)	Target Influent Concentration (ppm)	Actual Influent Concentration (ppmv) (µg/L)		Actual Effluent Concentration (ppmv) (µg/L)		TVH (%)	Benzene (%)	Lbs. Influent Ozone per Lbs. Influent TVH (O <sub>3</sub> /TVH)		
						(ppmv)	(µg/L)	(ppmv)	(µg/L)					
11/10/95	11:15-11:20	15	200	180	750	4.1	17	26	84	0.005	0.016	97.7	99.9	27.76
11/11/95	11:40-11:45	15	800	1,000	4,200	22	91	110	360	0.002	0.006	97.8	99.9	4.96
	16:30-16:45	15	1,500	1,600	6,600	53	220	10	32	ND	ND	96.7	99.9	3.15
11/12/95	09:30-09:40	15	3,000	2,700	11,000	310	1,300	56	180	0.035	0.110	88.5	99.9	1.89
	11:45-11:50	15	5,000	5,800	24,000	860	3,600	130	420	0.930	3.000	85.2	99.3	0.87
11/13/95	12:10-12:15	30	200	280	1,200	3	12	6.6	21	0.009	0.029	99.0	99.9	8.68
	14:30-14:40	30	800	1,100	4,600	17	71	21	68	0.006	0.019	98.5	99.9	2.26
	17:00-17:10	30	1,500	1,600	6,600	150	620	32	100	0.079	0.26	90.6	99.8	1.58
11/14/95	08:00-08:10	30	3,000	2,900	12,000	480	2,000	73	240	4.6	15	83.4	93.7	0.87
	11:20-11:30	30	5,000	6,000	25,000	1,700	7,100	160	520	48	160	71.7	70.0	0.42
11/21/95		30	800	1,100	4,600	210	870	17	55	0.25	0.81	80.9	98.5	2.26
11/30/95		30	1,500	1,600	6,600	270	1,100	38	120	0.09	0.29	83.1	99.8	1.58
12/8/95		30	1,500	1,300	5,400	350	1,400	25	81	0.099	0.32	73.1	99.6	1.93
12/19/95		30	1,500	1,100	4,600	420	1,700	24	78	0.65	2.1	61.8	97.3	2.26