



National Defence
Research and
Development Branch

Défense nationale
Bureau de recherche
et développement

TECHNICAL MEMORANDUM 96/237
March 1997

PREDICTING RADIATED SOUND
FROM A
SUBMERGED RING-STIFFENED CYLINDER

Latyon E. Gilroy

DISTRIBUTION STATEMENT A

Approved for public release
Distribution Unlimited

19970428 195

**Defence
Research
Establishment
Atlantic**



**Centre de
Recherches pour la
Défense
Atlantique**

Canada

DND QUALITY IMPROVED 1

DEFENCE RESEARCH ESTABLISHMENT ATLANTIC

9 GROVE STREET

P.O. BOX 1012
DARTMOUTH, N.S.
B2Y 3Z7

TELEPHONE
(902) 426-3100

CENTRE DE RECHERCHES POUR LA DÉFENSE ATLANTIQUE

9 GROVE STREET

C.P. BOX 1012
DARTMOUTH, N.É.
B2Y 3Z7



National Defence
Research and
Development Branch

Défense nationale
Bureau de recherche
et développement

PREDICTING RADIATED SOUND
FROM A
SUBMERGED RING-STIFFENED CYLINDER

Latyon E. Gilroy

March 1997

Approved by R.W. Graham:
Head/Hydrodynamics Section

TECHNICAL MEMORANDUM 96/237

Defence
Research
Establishment
Atlantic



Centre de
Recherches pour la
Défense
Atlantique

Canada

Abstract

Defence Research Establishment Atlantic (DREA) conducted experiments involving the measurement of radiated noise from a submerged ring-stiffened cylinder subjected to a harmonic load. These experiments were performed to provide validation data for structural acoustics computer codes being developed in-house and under contract. These codes are used to predict the vibrations of structures submerged in, or filled with, a dense fluid and also to predict the resulting radiated noise. This suite of codes, comprising the programs VAST, COUPLE, and BEMAP, was used to predict the natural frequencies and radiated noise, on- and off-resonance, from this cylinder. Comparisons are made between the predicted and measured natural frequencies and radiated noise levels and directivity. Overall, the programs were able to accurately predict both the structural resonances and the radiated noise patterns.

Résumé

Le Centre de Recherche pour la Défense Atlantique (CRDA) a conduit des expérimentations mettant en oeuvre des mesures du bruit rayonné par un cylindre renforcé par des anneaux, immergé et soumis à un chargement harmonique. Ces expérimentations ont été conduites afin de fournir des données pour valider des codes de structures utilisés en acoustique actuellement en développement interne ou sous contrat. On utilise ces codes de calcul pour prédire les vibrations des structures immergées dans un fluide dense ou remplies d'un tel fluide. On les utilise aussi pour prédire les bruits rayonnés dans de telles conditions. Cet ensemble de code, qui comprend les programmes VAST, COUPLE et BEMAP, a été utilisé pour prédire les fréquences propres et les bruits rayonnés par ce cylindre. Des comparaisons ont été faites entre les fréquences propres prédites et celles qui ont été mesurées. Les niveaux des bruits rayonnés ainsi que les directivités de ces bruits ont également été comparées. Dans l'ensemble les programmes se sont montrés capables de prédire de façon précise à la fois les résonances des structures et les bruits rayonnés.

Predicting Radiated Sound from a Submerged Ring-Stiffened Cylinder

by

L. E. Gilroy

Executive Summary

Introduction

Suites of computer codes have been developed at Defence Research Establishment Atlantic (DREA) to predict the radiated noise from submerged or floating elastic structures. These codes have been developed in support of the Ship Noise Project whose objective is to provide DND with the expertise and tools necessary to deal with issues related to underwater noise from naval vessels. Such computer programs may be used to either optimize the structural arrangement to minimize radiated noise or to examine existing structures to isolate noise-producing structures. DREA has conducted several sets of experiments at DREA's Acoustic Calibration Barge to measure the natural frequencies and radiated noise from a submerged ring-stiffened cylinder subjected to a harmonic load in order to provide validation data for the computer codes.

Principal Results

DREA's ring-stiffened cylinder, measuring 3m long by 0.76m in diameter, was tested at the Acoustic Calibration Barge in the spring of 1993 and the summer of 1994. During the test periods, the natural frequencies and mode shapes of the cylinder were measured with excitation provided by an electromagnetic shaker. This testing was performed with the cylinder submerged vertically, i.e., the long axis of the cylinder pointed at the water surface. Directivity patterns were measured by rotating the vertical cylinder (while the cylinder was excited with the shaker) and measuring the resulting radiated noise using a hydrophone at a specified position. Directivity patterns were also measured while rotating the cylinder in a horizontal position and also with the cylinder fixed in the vertical position and the hydrophone moved in a linear fashion using the mobile trolleys of the barge.

The cylinder was then modelled using the finite element analysis program, VAST, and the surrounding fluid was modelled using the COUPLE finite element program. The natural frequencies of the cylinder were calculated with the VAST/COUPLE combination and compared with those measured in the trials. A point sinusoidal load of fixed amplitude was then applied to the model at each frequency of interest to simulate the load applied by the shaker and the resulting surface velocities of the cylinder were determined. These surface velocities were used as input to the boundary element program, BEMAP, which calculated the radiated sound at each frequency for comparison to the measured directivity patterns.

The predictions of the natural frequencies were generally accurate to within ten percent. Overall, the predictions at resonance were quite accurate in directivity, quite accurate in sound level for some modes, and quite poor in sound level for other modes. The off-resonance predictions were quite accurate with excellent predictions of directivity pattern and usually reasonable predictions of sound level.

Significance of Results

The accuracy of the comparisons between the numerical and experimental predictions indicates that the suite of computer codes comprising VAST, COUPLE, and BEMAP are capable of predicting the radiated noise of a submerged structure resulting from excitation of structural resonances. The data also indicate the importance of an accurate assessment of the structural damping, without which accurate prediction of the radiated sound levels is quite difficult.

Future Plans

Given the reasonable success of these trials in predicting the radiated noise from a relatively simple submerged structure, it is necessary to perform similar combined experimental/numerical trials on a more complex structure. Several candidates are being examined including a relatively simple ship tank model, a more complex submarine model being tested by the German defence department, and the DREA Acoustic Barge itself. These trials would verify the operation of the programs on structures more closely resembling actual ships or submarines with all their inherent structural complexities while allowing reasonable access to the structures for experimental purposes. The boundary element-based program, AVAST (developed under contract to DREA), will also be used as a replacement for the commercial program, BEMAP.

Contents

Executive Summary	iii
1 Introduction	1
2 Experimental Procedure	1
2.1 Equipment	1
2.2 Natural Frequencies	3
2.3 Directivity Patterns	5
3 Numerical Codes	6
4 Numerical Model	8
5 Results	10
5.1 Resonant Frequencies	10
5.2 Directivity Patterns	10
6 Conclusions	13
Annex A: Directivity Plots - 1993	15
Annex B: Directivity Plots - 1994	41
References	64

1 Introduction

Suites of computer codes have been developed at Defence Research Establishment Atlantic (DREA) to predict the radiated noise from submerged or floating elastic structures [1, 2, 3, 4]. These codes have been developed in support of the Ship Noise Project whose objective is to provide DND with the expertise and tools necessary to deal with issues related to underwater noise from naval vessels. Such computer programs may be used to either optimize the structural arrangement to minimize radiated noise or to examine existing structures to isolate noise-producing structures. DREA has conducted several sets of experiments at DREA's Acoustic Calibration Barge [5, 6] to measure the natural frequencies and radiated noise from a submerged ring-stiffened cylinder subjected to a harmonic load in order to provide validation data for the computer codes.

DREA's ring-stiffened cylinder, measuring 3m long by 0.76m in diameter, was tested at the Acoustic Calibration Barge in the spring of 1993 and the summer of 1994. References [7, 8] provide a detailed account of the first set of trials. During the test periods, the natural frequencies and mode shapes of the cylinder were measured using either strain gauges or accelerometers placed throughout the cylinder with excitation provided by an electromagnetic shaker. This testing was performed with the cylinder submerged vertically, i.e., the long axis of the cylinder pointed at the water surface. Directivity patterns were measured by rotating the vertical cylinder (while the cylinder was excited with the shaker) and measuring the resulting radiated noise using a hydrophone at a specified position. Directivity patterns were also measured while rotating the cylinder in a horizontal position and also with the cylinder fixed in the vertical position and the hydrophone moved in a linear fashion using the mobile trolleys of the barge.

The cylinder was then modelled using the finite element analysis program, VAST [9] and the surrounding fluid was modelled using the COUPLE [1, 2, 3, 4] finite element program. The natural frequencies of the cylinder were calculated with the VAST/COUPLE combination and compared with those measured in the trials. A point sinusoidal load of fixed amplitude was then applied to the model at each frequency of interest to simulate the load applied by the shaker and the resulting surface velocities of the cylinder were determined. These surface velocities were used as input to the boundary element program, BEMAP [10], which calculated the radiated sound at each frequency for comparison to the measured directivity patterns.

This technical memorandum describes the dimensions of the cylinder and the experimental procedure and compares the results of the natural frequency testing and the measured directivity patterns with the predicted values. A more detailed description of the first experiment is given in [7].

2 Experimental Procedure

2.1 Equipment

The ring-stiffened right cylinder of length 3m and diameter 0.76m was manufactured at the Ship Repair Unit (Atlantic) machine shops with material provided by DREA [11]. The cylindrical

part itself was purchased as a 9.5mm thick tube with a nominal diameter of 762mm, with a weld seam running longitudinally along the entire length. Five circumferential stiffeners were welded into the tube at equal intervals of 0.5m. These stiffeners had a square 38.1mm \times 38.1mm cross-section. Threaded 9.5mm radial holes facing inwards were also provided at 45° intervals on every ring stiffener to allow for the attachment of various pieces of equipment.

Removable endcaps 76.2mm thick were constructed of nominal 3in plate and welded to the tube. The endcaps were of two pieces with a central 'hatch' roughly 600mm in diameter, which was bolted to the remainder of the endcap and sealed with an O-ring. Ring bolts were welded to the endcaps at various positions to allow for handling of the cylinder and the endcaps. A sketch of the cylinder cross-section is shown in Figure 1 and a photograph of the cylinder on its transport carriage is shown in Figure 2.

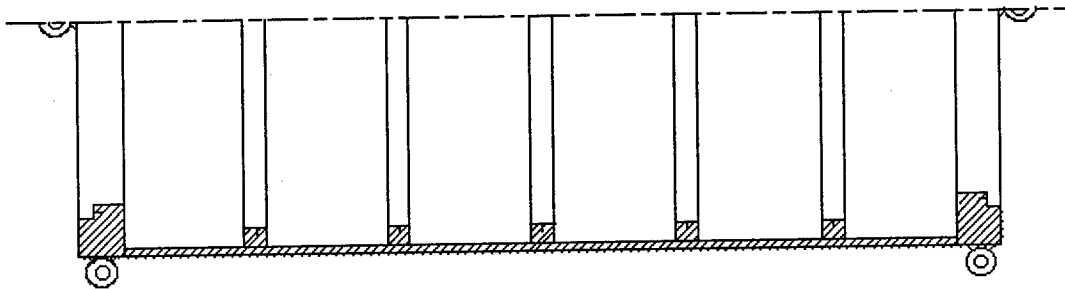

Figure 1: Half-Section Through Test Cylinder

Four 24-pin Envirocon marine connectors penetrated one endcap (called the *front* endcap) to allow for the wiring of the strain gauges or accelerometers and force transducers. A 4-pin Marsh Marine connector was used to provide power for the electromagnetic shaker. An air fitting was also provided in the front end to allow for pressure testing of the cylinder.

In the first set of trials, strain gauges were installed on the cylinder as shown in Figure 3 (gauges 9 and 10 and gauges 22 and 23 occupy similar locations but are oriented in orthogonal directions).

A Brüel & Kjær PM Vibration Exciter Type 4809 was installed such that the main body of the exciter was bolted to the center stiffener. A Brüel & Kjær Type 8201 force transducer was installed in the shaker drive rod. There was concern about significant load being transmitted through the shaker base, so the mount was also gauged. This gauge did not function during the trials, so it was not possible to determine if another load path existed for the excitation force.

While results were measured using this system, it was found that the strain gauges were not an effective tool for determining resonant frequencies (relatively low signal-to-noise) and were very poor for determining mode shapes. In the second set of trials, accelerometers were used (Kistler Model 8632) in place of the strain gauges resulting in much easier determination of resonant characteristics. The accelerometers (48 in total) were positioned in essentially the

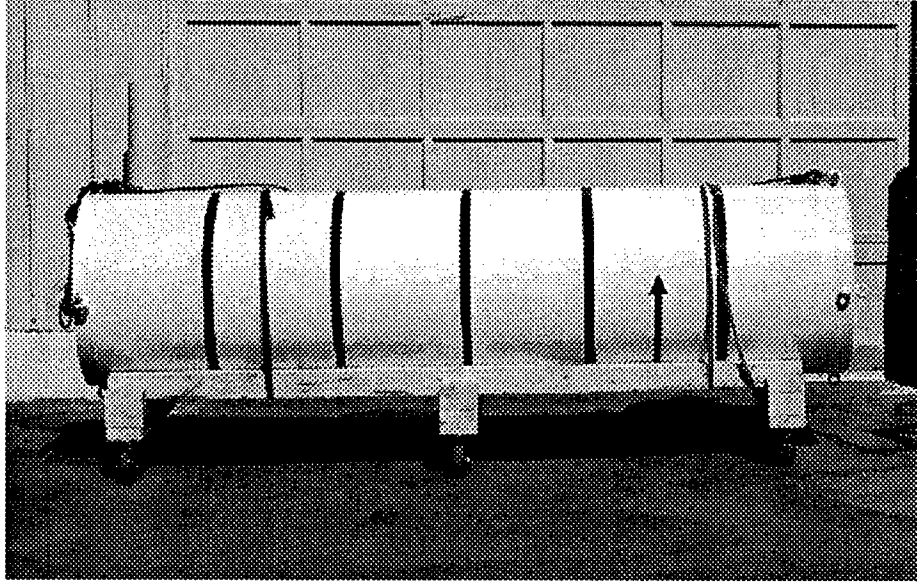

Figure 2: Test Cylinder

same way as the strain gauges. As well, due to the concerns of the two-point mount of the shaker, a more powerful shaker (a Wicoxon Model F4/F7) which utilizes a single-point mount was used in subsequent trials.

2.2 Natural Frequencies

The cylinder was mounted on the large station at one end of the well in DREA's Acoustic Calibration Barge. The cylinder was bolted to the bottom of the station and lowered into the water in the vertical position. The station was equipped with a drive allowing for accurate remote rotational control. The station was also equipped with a number of 3.05m extender pipes for deeper submergence of the cylinder. The responses of the various accelerometers (or strain gauges) were examined under loadings from either the shaker or an underwater sound projector deployed in close proximity to the cylinder. Examination of the sensor response spectra yielded the cylinders natural frequencies. Efforts were made to determine each resonant mode shape using comparisons of the relative magnitudes and phases of the response between sensors at each resonant peak. The determination of the mode shape was extremely difficult and, in many cases, impossible using the strain gauges. It was not until the subsequent trials using the accelerometers that several modes were identified. Damping factors for each resonant mode were also measured using the half-power point of the resonant peak.

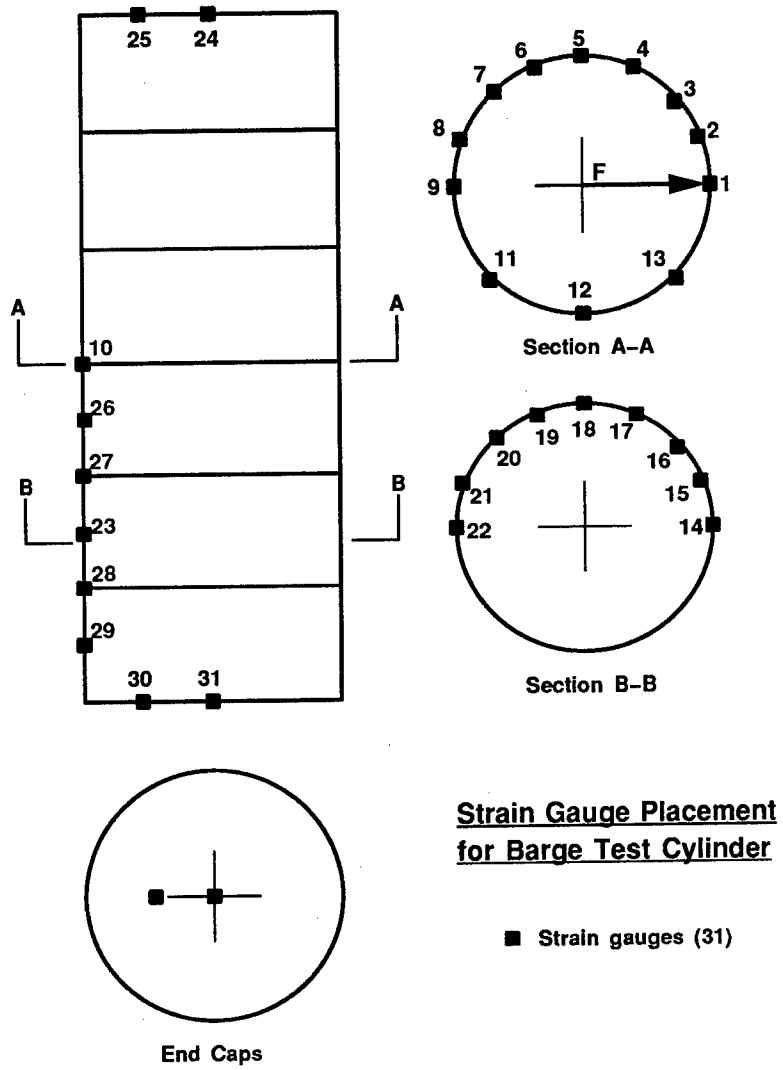

Figure 3: Strain Gauge Setup

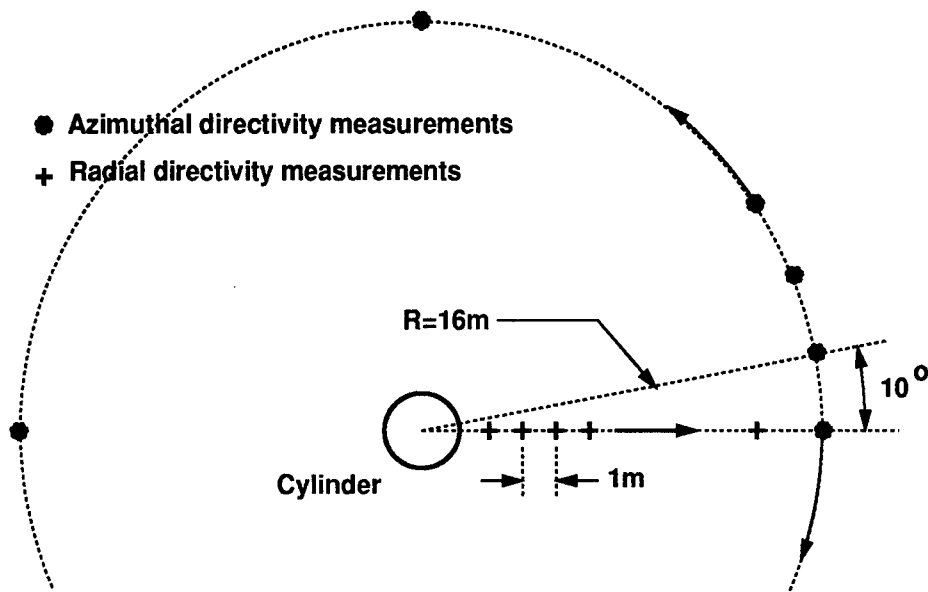

Figure 4: Vertical Cylinder Directivity Measurements

2.3 Directivity Patterns

The measurements of directivity patterns were performed in essentially the same way for all of the trials. Azimuthal directivity patterns were measured for the cylinder in the vertical position with the shaker providing excitation at selected frequencies. A hydrophone was attached to a station on one of the instrumentation trolleys at a distance of 16m from the axis of the cylinder. Measurements were made at selected frequencies with the hydrophone while the cylinder was rotated through 360 degrees in 10 degree increments. Radial directivity pattern measurements were also made with the cylinder in the vertical position, but, instead of rotating the cylinder, the hydrophone was moved away from the cylinder in a straight line over about a 10m range with measurements made every metre. The directivity measurements for the vertical cylinder are illustrated in Figure 4. Circular directivity pattern measurements were also made with the cylinder mounted in the horizontal direction, as shown in Figure 5. For both circular patterns, both cylinder depth and hydrophone depth were varied for a range of conditions.

All radiated noise measurements were performed at discrete frequencies using pure sinusoidal inputs to the shaker. The discrete frequencies were chosen based on two criteria: they had to be modes which could be excited by the shaker in the given position and they had to be dominant modes with strong signal to noise ratios. It was not feasible to use a pulsed signal due to the reflections of the acoustic signal off the barge and bottom and the relatively low frequencies used. The use of a pulsed signal would have allowed the assumption of an infinite acoustic medium if only the outgoing signal were considered (only the first response is measured, any reflections

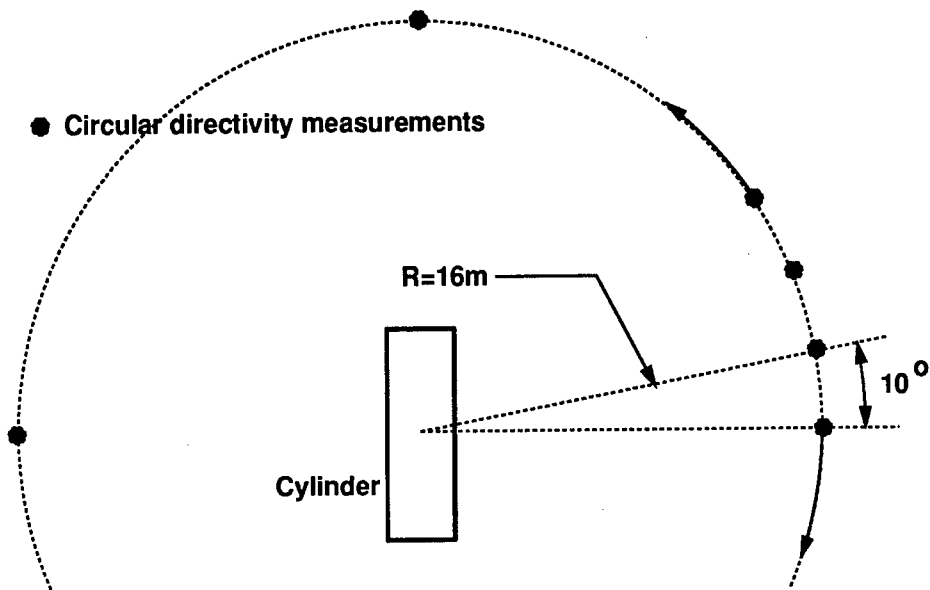

Figure 5: Horizontal Cylinder Directivity Measurements

are ignored), which would simplify the numerical modelling. Some directivity patterns were also measured at off-resonant frequencies which were selected such that they were distant in frequency from resonant frequencies. Voltage levels from the force transducers on the shakers were also recorded and were converted to Newtons (rms). The force applied to the numerical model was set at 10 N (peak) so all experimental measurements were scaled to this force level based on the recorded force input.

The test matrix covering the three sets of trials is given in Table 1. In the 1994 tests, there were originally 10 vertical cylinder tests (1-10) and 2 horizontal cylinder tests (1-2), but the omitted test results were in higher frequency ranges not appropriate to this analysis.

3 Numerical Codes

The VAST code was used for the structural analysis of the cylinder. VAST (Vibration And STrength) is a general purpose, finite element computer code for the analysis of complex structures which has been developed both in-house at DREA and through contracted research since the early 1970's. Over the twenty years of development, many general purpose and special features for naval structural analysis have been implemented in VAST. These include specialized pre- and post-processors, as well as links to commercial model generators, a substantial library of element types, and a wide range of analysis options consisting of the usual linear static, dynamic and eigenvalue solutions. More recent additions to VAST include: large displacement

Date and Pattern Type	Test Number	Cylinder Depth (m)	Hydrophone Depth (m)
1993			
Azimuthal (Vertical Cylinder)	1	3.45	3.45
	2	6.50	6.32
	3	6.50	6.32
	4	9.55	9.37
	5	9.55	9.37
	6	9.55	10.90
	7	9.55	7.85
	8	15.65	15.47
Circular (Horizontal Cylinder)	9	2.92	3.28
	10	5.97	6.32
	11	9.02	9.37
	12	12.07	9.37
	13	12.07	12.42
	14	12.07	15.47
1994			
Azimuthal (Vertical Cylinder)	3	6.50	6.50
	4	6.50	12.60
	5	6.50	12.60
	6	12.60	12.60
	7	18.70	12.60
	8	12.60	12.60
	9	12.60	12.60
Radial (Vertical Cylinder)	L1	6.50	6.50
	L2	12.60	12.60
Circular (Horizontal Cylinder)	1	6.50	6.50

Table 1: Cylinder Directivity Pattern Tests

nonlinearity; random response to sea spectra loading; stochastic finite element analysis (FEA); elasto-acoustic analysis; complex eigenvalue solutions for vibration isolation; and component mode synthesis.

COUPLE is a fluid finite element matrix assembly code used for the analysis of rigid walled cavities and for fluid-structure interaction problems. The complete theoretical background to the development of COUPLE is discussed in [1, 2, 3, 4].

The program COUPLE is not a stand-alone code. It requires VAST for evaluating the structural model and solving the combined system. The model of the structure is generated for a standard structural analysis and is run through VAST to the point where the mass and stiffness matrices are generated. The corresponding fluid model is generated and run through COUPLE to assemble the fluid stiffness and mass matrices. COUPLE then reads in the structural matrices and performs any modifications such as inverses or transposes to the two sets of matrices before combining them in the desired form of assembled fluid/structure stiffness and mass matrices. If only a cavity analysis is being performed, the structural information is not required. The assembled stiffness and mass matrices, along with a dummy geometry file, are then rerun through the VAST program for decomposition and calculation of the mode shapes and natural frequencies of the coupled fluid/structure system.

This combination of COUPLE and VAST may be used for structures that either contain or are surrounded by fluid. Further analysis of coupled systems using the VAST frequency response capability and the commercial boundary element code, BEMAP, allows the prediction of acoustic radiation from models excited by externally applied loads.

BEMAP (Boundary Element Method for Acoustic Prediction) uses the Boundary Element Method (BEM), also known as the Boundary Integral Equation (BIE) Method, to calculate the acoustic field due to an arbitrary body vibrating at a specified frequency or to calculate the acoustic field inside of an arbitrarily shaped acoustical cavity. Further information on this method may be found in [10] and other well-known references. The frequency response module in VAST is used to predict the surface velocities of the structure which are converted to normal velocities, and passed to BEMAP which then goes on to predict the resulting acoustic radiation.

4 Numerical Model

The structural model was constructed using the 4-noded shell elements and the 2-noded beam elements available in VAST. A total of 962 nodes and 960 elements were used to describe the cylindrical shell and endcaps and an additional 160 elements were used to describe the ring stiffeners. This resulted in the finite element model shown in Figure 6.

For the COUPLE analysis, a finite element model of the fluid is required and the model used is shown in Figure 7. This model is composed of 4-noded interface elements, a 0.5 m thick layer of 8-noded brick elements, and a layer of 8-noded infinite brick elements (indicated by the external radial lines in the figure). Each layer of fluid elements consisted of 960 elements. This resulted in a total of 2886 fluid degrees of freedom. For the BEMAP portion of the coupled analysis, the boundary element grid used was the same as the surface grid of the structural FE

model.

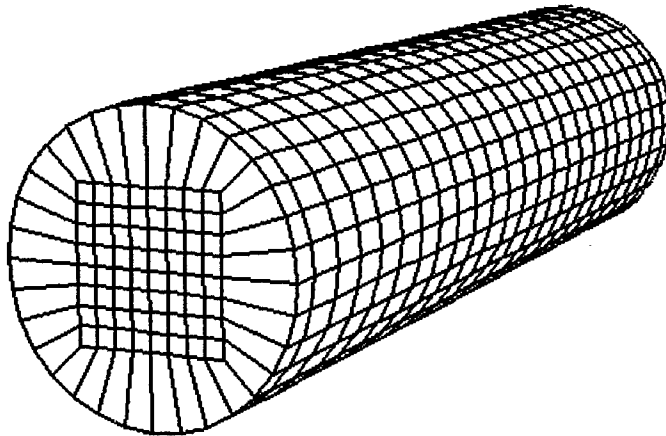

Figure 6: Finite Element Model of Cylinder

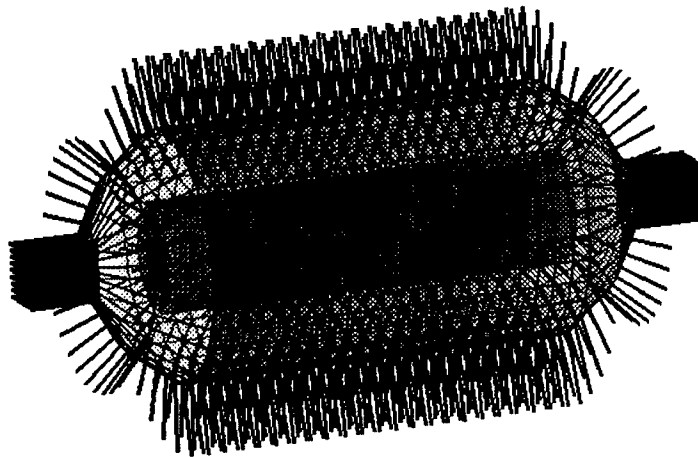

Figure 7: FE Fluid Model for Submerged Cylinder

As the cylinder was very close to being neutrally buoyant when submerged, free-free boundary conditions were applied to the finite element model. No other constraints were provided. A lumped mass was added to the model to represent the electromagnetic shaker.

5 Results

5.1 Resonant Frequencies

The results of the VAST/COUPLE natural frequency analysis are shown in Table 2 along with the natural frequencies found during the experiments using both the shaker and the sound projector, as well as the damping factors and mode type associated with each mode. The letter N indicates the order of the circumferential mode (number of full sine waves) and M the longitudinal (number of half sine waves).

The initial testing was only partly successful in determining the mode shapes associated with a particular resonance. Difficulties were encountered in producing a clear pattern for many of the higher modes. In particular, there seemed to be some unexplained duplication of the experimental 4,1 mode which was not apparent in the numerical model. While the numerical model does predict two frequencies for each mode, these frequencies are orthogonal pairs and, by symmetry, have the same value for even values of M and slightly different values for odd M (due to the shaker). However, it is unlikely that mode shapes with the shaker at a null (which is the case for one of the orthogonal pairs) would be excited by the shaker. An apparent 1,3 mode also appeared in multiple locations in the numerical model, with the first appearance being reasonably identifiable, but the subsequent appearances less so. This poor definition may be indication of some confusion between this mode and the 1,4 and 1,5 nodes which do not appear as separate entities in the model. The numerical 1,3 1,4 and 1,5 entries in Table 2 are inferred from the order in which these modes should have appeared. The torsion and endcap modes were not measured during the testing due to difficulties in exciting those particular modes. In any event, the cylinder endcaps were not particularly well modelled, as we were not interested in their response.

Examination of Table 2 shows that the resonant frequencies were generally predicted quite accurately by the numerical analysis, with most predicted values within ten percent of the measured values. Given that the material properties were not known exactly, this was quite reasonable accuracy.

5.2 Directivity Patterns

Once the validity of the numerical model was established by the accuracy of the natural frequency predictions, a frequency response analysis was performed using the VAST FE code. The modal superposition method was used, which utilizes the predicted resonances as a basis set for predicting the response of the structure in the frequency range spanned by the resonances. The method requires both the set of eigenvectors from the natural frequency analysis and modal damping factors for each mode included in the set. The damping factors used were those measured during the trials. Ideally, theoretical damping factors should be used and the results compared with the measured values; however, theoretical values of damping factors could not be found for such a welded steel structure. The use of the measured values, of course, indicates a deficiency in our capability for predicting the radiated noise at resonance.

No.	Experimental Frequency (Hz)	Mode (N,M)	Damping Factor (%)	Predicted Frequency	Percent Error
1	118.8	2,1	0.1120	112.9	-5.0
2	186.7	1,1	1.04	192.4	3.1
3	191.4	2,2	0.0522	202.3	5.7
4	266.7	Breathing	1.30	277.0	3.9
5	314.4	3,1	0.0530	305.1	-3.0
6	316.4	2,3	0.0527	347.5	9.8
7	334.4	3,2	0.0399	332.3	-0.6
8		Torsion		355.8	N/A
9		Endcap		356.0	N/A
10		Endcap		357.5	N/A
11	375.8	3,3	0.0355	387.6	3.1
12	393.0	1,2	1.24	397.6	1.2
13	445.2	3,4	0.0624	480.4	7.9
14	460.2	1,3	0.0724	459.8	-0.1
15	484.4	4,1	0.0390	532.4	9.9
16	485.9	4,1	0.0287	532.4	9.6
17	490.6	4,1	0.0272	532.4	8.5
18	499.2	4,2	0.0390	541.2	8.4
19	522.6	1,4	0.0425	520.5	-0.4
20	532.0	3,5	0.0522	589.7	10.8
21	546.9	4,3(?)	0.0408	556.3	1.7
22	557.0	5,1(?)	0.0339	N/A	N/A
23	558.6	5,1(?)	0.0318	N/A	N/A
24	571.1	2,4	0.1560	516.2	-9.6
25	588.3	5,1(?)	0.0604	N/A	N/A
26	598.4	2,5	0.1000	618.7	3.4

Table 2: Natural Frequencies (Hz) of Cylinder

The response of the cylinder was calculated for the same modes for which directivity plots were made, as well as the off-resonant frequencies. As the calculated resonant frequency is different from the measured value, the exact same frequency was not used, but rather, the results were calculated for the same mode to insure that the resonant response was modelled correctly. The VAST frequency response module produces nodal displacement amplitudes for each frequency of interest. A translator program was run to convert these displacements to nodal velocities, then to normal (to the surface) velocities which are the required input boundary conditions for the BEMAP code. The applied force in each case was assumed to be 10N (peak) and the experimentally measured results were scaled to match. This was done by measuring the applied load experimentally, determining the difference in dB between this experimental load and the numerical load (10N) and changing the measured sound pressure level (SPL) by this difference (this assumes the system is linear, which is a basic assumption of the theory in any case). The boundary element model for the BEMAP analysis used the same grid of 4-noded elements as was used in the FE analysis, but without modelling any stiffeners (only a surface model is required). The BEMAP program takes the geometry and the surface velocity boundary conditions and predicts the radiated sound pressure level at any requested set of field points. The sound speed and density for the acoustic fluid (salt water) were assumed to be 1500 m/s and 1025kg/m³, respectively. The BEMAP model also assumed the water and barge surface to be an infinite pressure release surface (not the best assumption for the barge hull, but a necessary one given that the elastic barge hull was not modelled) and the fluid domain to be semi-infinite. The actual hull of the barge was not taken into account. The directivity patterns are plotted in terms of Sound Pressure Level (SPL) and the radial scale is in dB re 1 μ Pa.

The resulting directivity patterns for the 1993 tests are contained in Annex A and those for the 1994 tests in Annex B. There is little variation in accuracy of the 1993 results from test to test. Typically, for the vertical tests in Annex A (Figures A1 to A38), the shape of the patterns are quite accurate and the levels are reasonably accurate, particularly for the maximum level in the pattern. Exceptions include the level of the 1,1 mode (first bending) pattern and the shape of the 4,1 mode. In all the 1993 tests, the level of the 1,1 mode is significantly underpredicted while the pattern is extremely accurate. This would indicate the actual damping is much less than the measured value which was significantly higher than the measured damping for other modes. Further measurements would seem to be warranted. Another possible explanation is some sort of resonance effect with other structures (such as the barge hull) which is ignored in the numerical model. Given the accuracy of the pattern, this is unlikely. The 4,1 mode seems to be quite poorly predicted, even though the level is roughly correct. A possible explanation is that there is some interaction with another structure which alters the pattern. The numerically predicted pattern is quite clear and unambiguous. This discrepancy also is apparent in the horizontal test cases. The 1993 horizontal tests (Figures A39 to A74) exhibit much the same characteristics as the vertical tests with the patterns being predicted well, in general, and the maximum levels slightly less accurate. Tests 12 through 14 also show results from off-resonance frequencies which show reasonable agreement in pattern, but, on average, about a 10 dB underprediction in level. The differences here may be accounted for by noting that the

selected frequencies may be closer or further away from a predicted resonance than a measured resonance with the resulting different levels of contributions from the nearest resonant modes.

The 1994 test results, shown in Annex B, cover more frequencies than the testing performed in 1993; however, similar conclusions may be drawn from the plotted directivity patterns for both the vertical and horizontal tests (Figures B1 to B35 and Figures B50 to B58). In most cases the predicted shape of the directivity pattern is quite accurate while the accuracy of the predicted level varies from excellent to poor. In contrast to the 1993 tests, the 1,1 mode (and the 3,1 mode, the 3,3 mode, the 2,3 mode, and the 3,5 mode) radiated noise levels are overpredicted by the numerical model. The most obvious explanation, given the accuracy with which the pattern is reproduced, is that the measured damping values were too low. The 2,1 mode and the 2,5 mode show excellent agreement between measured and predicted levels. There were three different experimental frequencies identified as the 4,1 mode and, in this set of trials, two of the three had directivity patterns measured. The first showed a similar trend to the 1993 measurement with poor agreement for both pattern and level. The second showed excellent agreement, although the measured pattern was not clearly defined. This would indicate that the first 4,1 mode may not be the true mode and shows up in the experiment due to some other unexplained resonance.

The linear directivity patterns (Figures B36 to B49) show similar patterns again with the predictions producing accurate shapes, but producing reasonable sound pressure levels for only about one half the tests. This again points to errors in measurements of modal damping.

6 Conclusions

Experiments were performed at DREA's Acoustic Calibration Barge to measure the natural frequencies of a submerged ring-stiffened cylinder and to measure acoustic radiation directivity patterns for the cylinder undergoing point-excitation. These experiments were performed to obtain data with which DREA structural and acoustic computer codes could be evaluated.

The DREA computer codes VAST and COUPLE were used for the prediction of the submerged cylinder's natural frequencies. The predicted frequencies showed excellent agreement with the experimental results with all predictions being within eleven percent of the measured values.

The results from the VAST/COUPLE analysis, along with the boundary element program, BEMAP, were then used to predict the radiated sound pressure level (SPL) directivity patterns at both resonant and off-resonant frequencies for the cylinder in a variety of configurations. Overall, the predictions at resonance were quite accurate in shape, quite accurate in SPL for some modes, and quite poor in SPL for other modes.

Typically the $N=2$ modes were well predicted and the $N=3$ modes showed good agreement in pattern shape, but mixed agreement in level. The first bending mode (1,1) showed good agreement in shape, but the level was significantly underpredicted in one set of trials and overpredicted in the other. The 4,1 mode was quite poorly predicted in general.

A major deficiency identified in this analysis was the lack of theoretical modal damping

factors for the cylinder which could be used in the prediction of radiated noise level. In the analysis, measured values were used, but ideally, it should be possible to predict the radiated noise without making any measurements. Unless methods are developed which can predict modal damping for general structures, empirical data will have to be developed from which representative modal factors may be drawn. DREA has measured modal damping factors from trials with this cylinder both submerged and floating and will be measuring damping factors from a floating box-like structure in an upcoming trial. These data will be compared in an attempt to develop modal damping factors representative of ship-like resonances.

In general, the suite of programs comprising VAST, COUPLE, and BEMAP have shown a capability for predicting the natural frequencies and radiated noise of a vibrating structure. It has also been shown that the prediction of the radiated noise level is dependent on accurate identification of modal damping factors for radiation at a structural resonance.

A Directivity Plots - 1993

A.1 Vertical Cylinder

A.1.1 Test 1

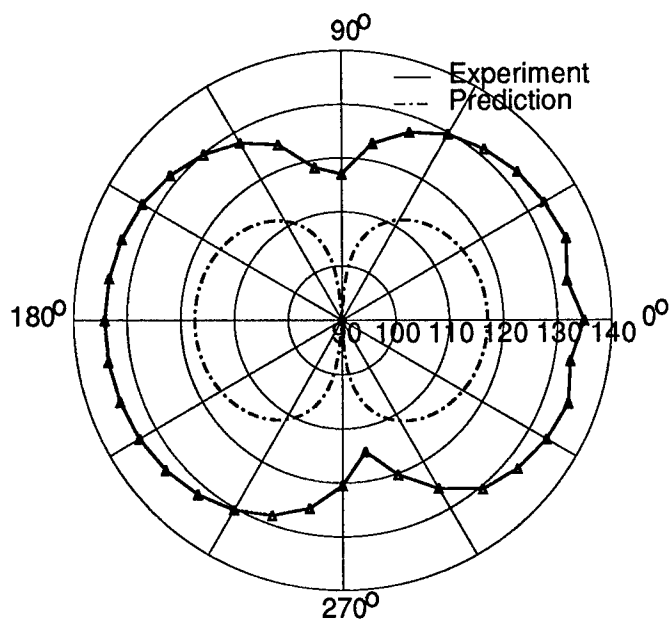
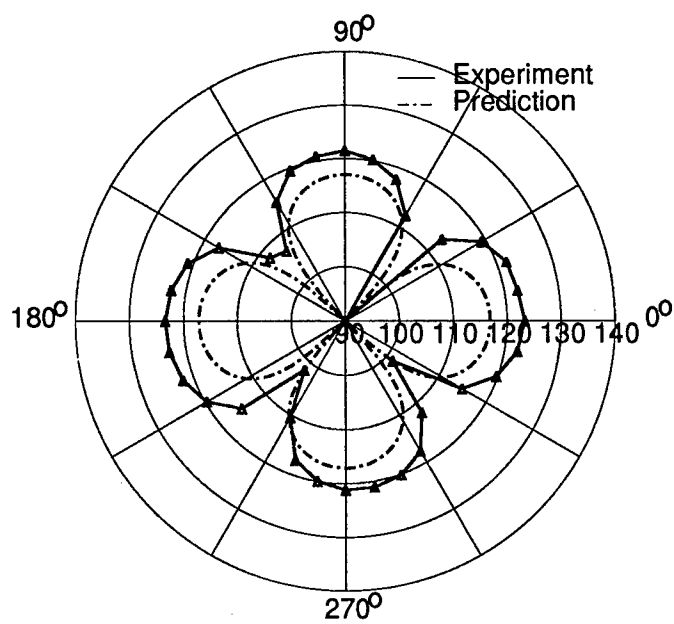

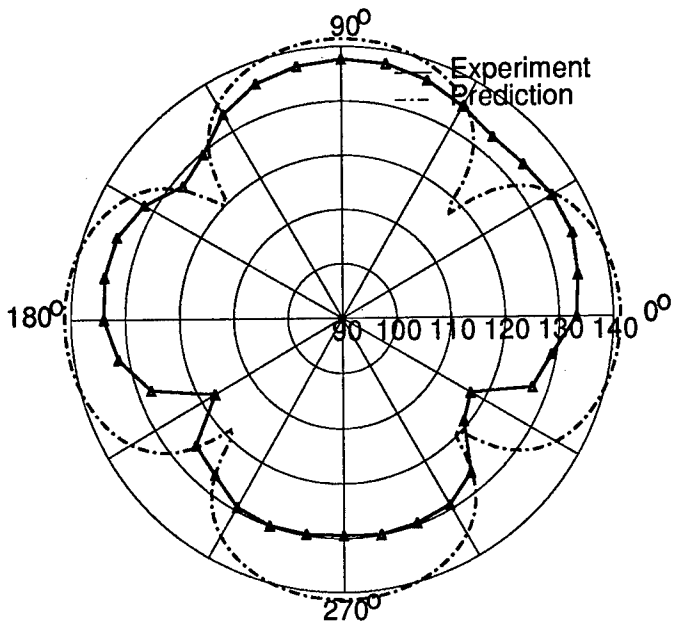

Figure A3: Test 1 - 2,3 Mode

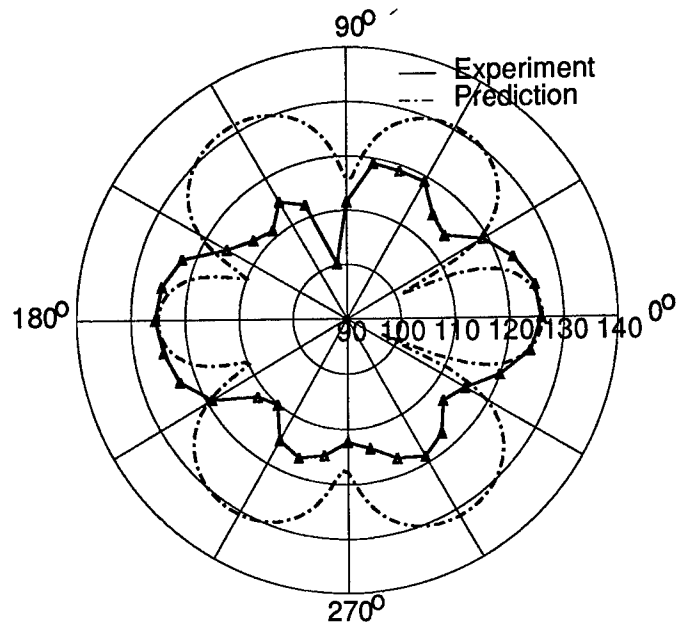

Figure A4: Test 1 - 3,3 Mode

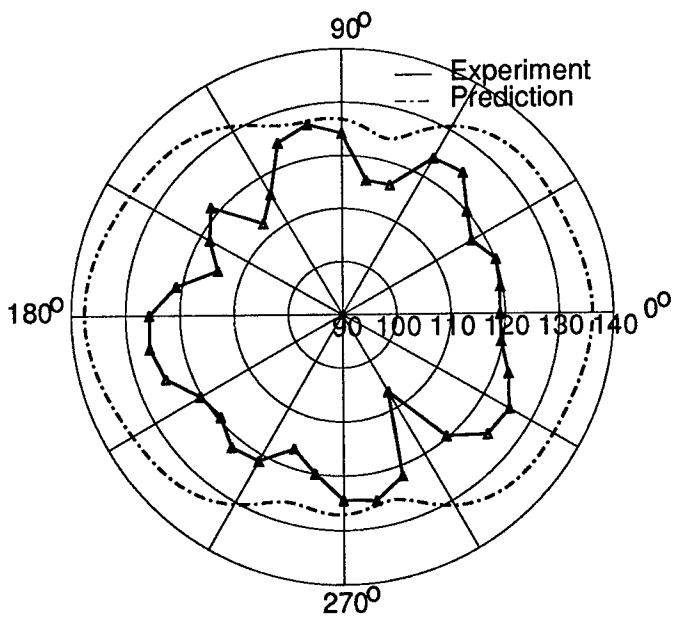

Figure A5: Test 1 - 4,1 Mode

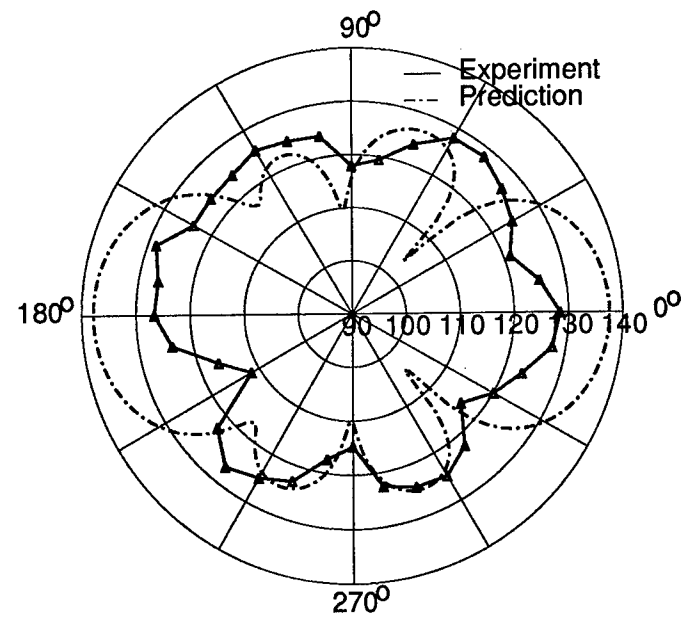

Figure A6: Test 1 - 3,5 Mode

A.1.2: Test 2

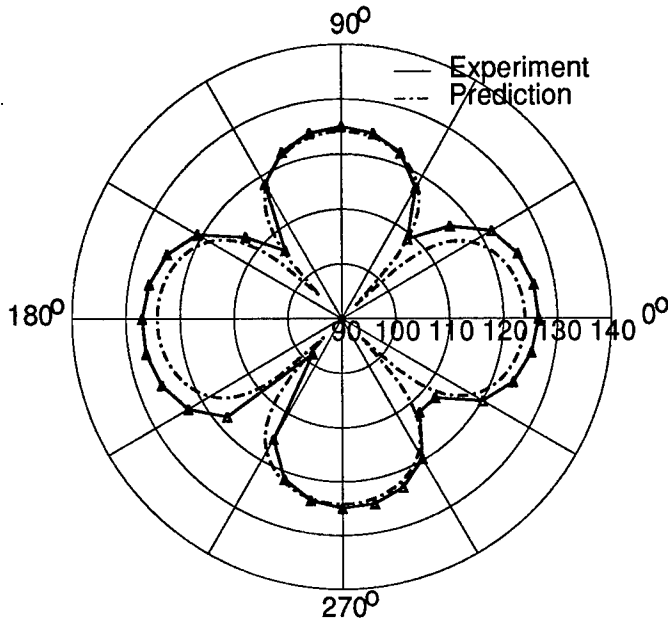

Figure A7: Test 2 - 2,1 Mode

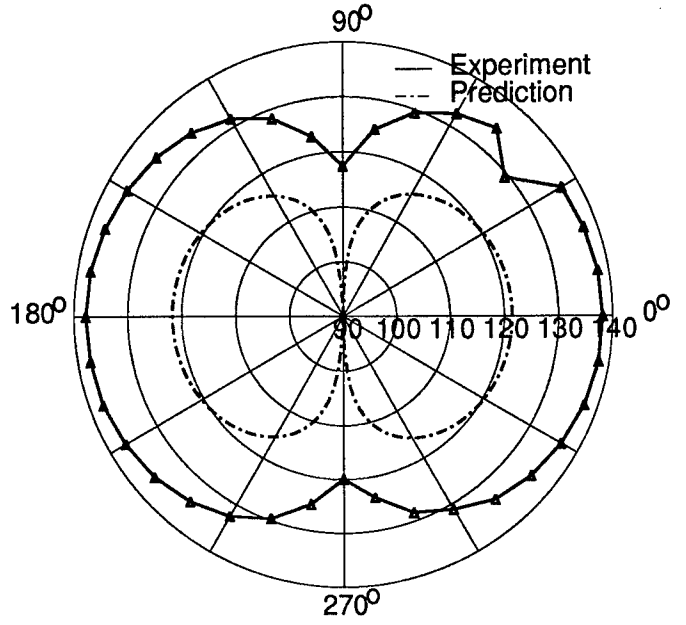

Figure A8: Test 2 - 1,1 Mode

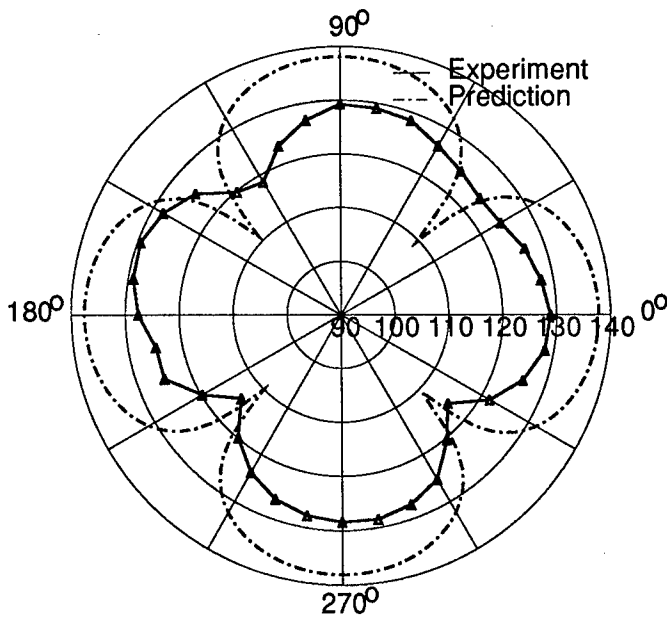

Figure A9: Test 2 - 2,3 Mode

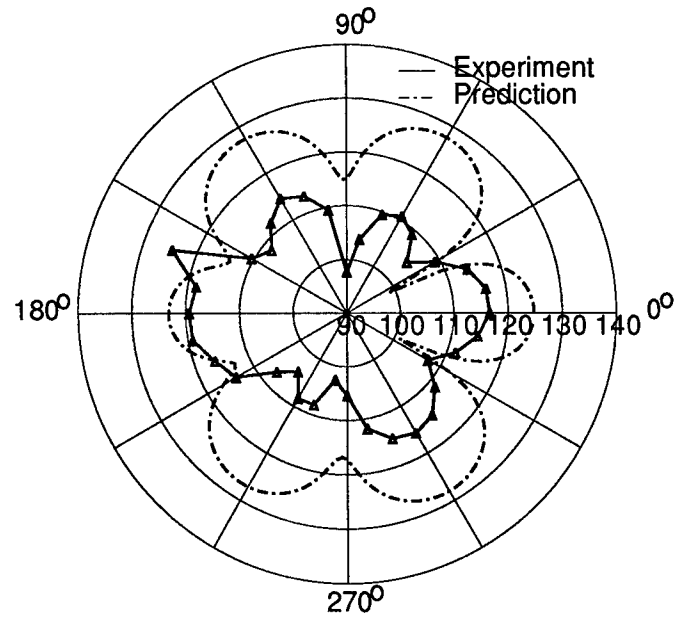

Figure A10: Test 2 - 3,3 Mode

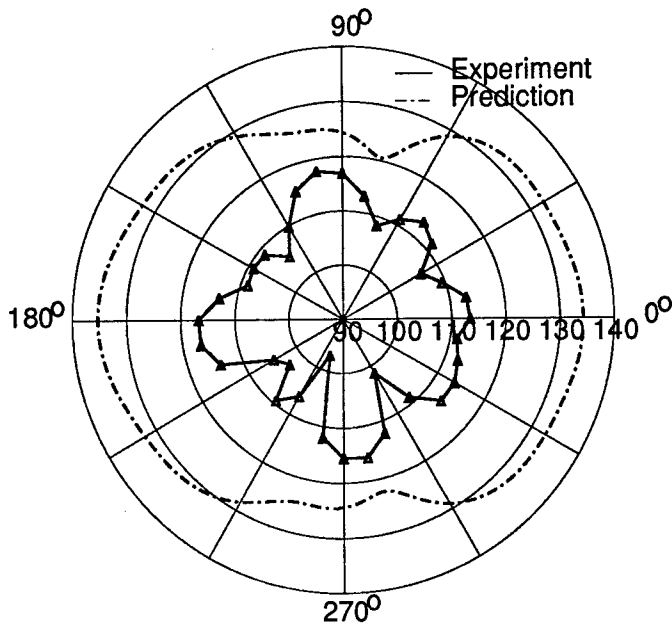

Figure A11: Test 2 - 4,1 Mode

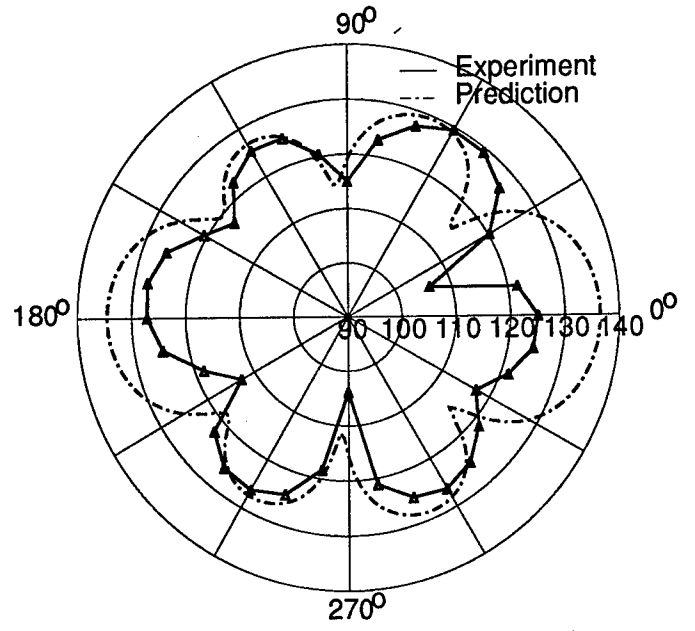

Figure A12: Test 2 - 3,5 Mode

A.1.3 Test 3

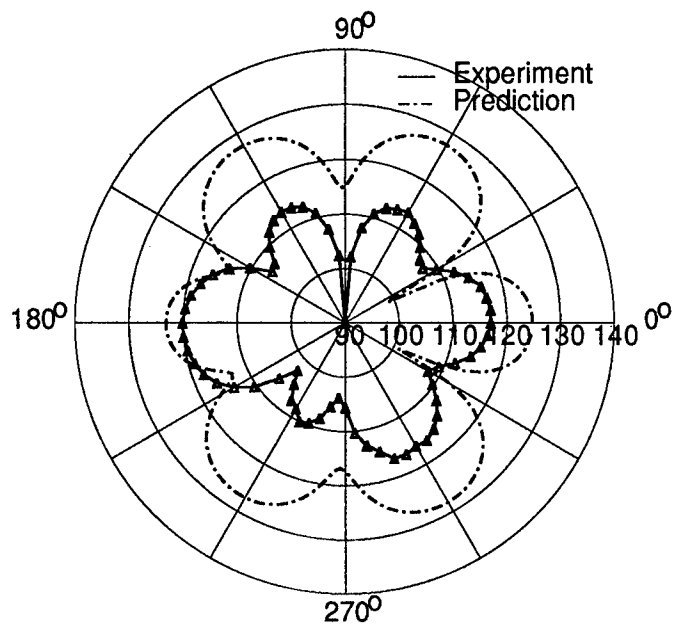

Figure A13: Test 3 - 3,3 Mode

A.1.4: Test 4

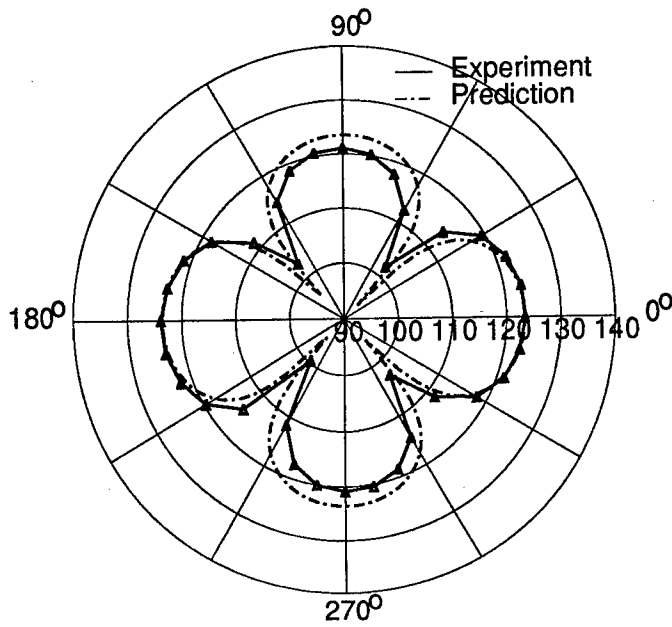

Figure A14: Test 4 - 2,1 Mode

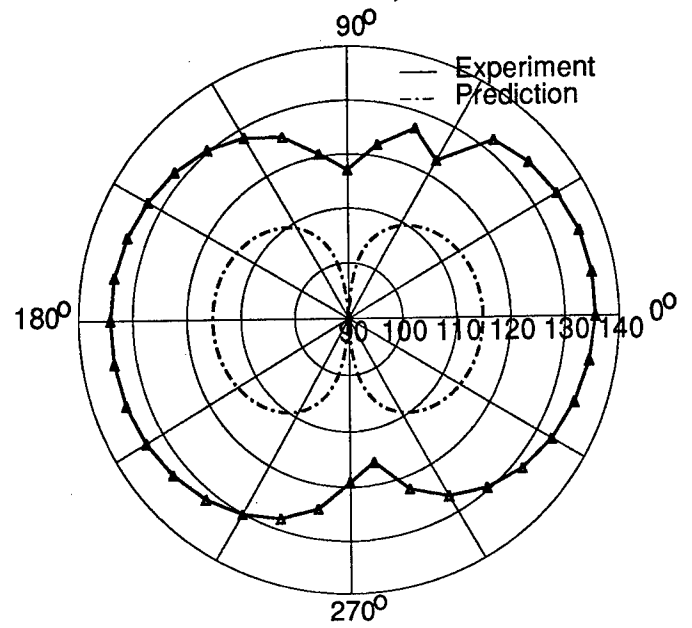

Figure A15: Test 4 - 1,1 Mode

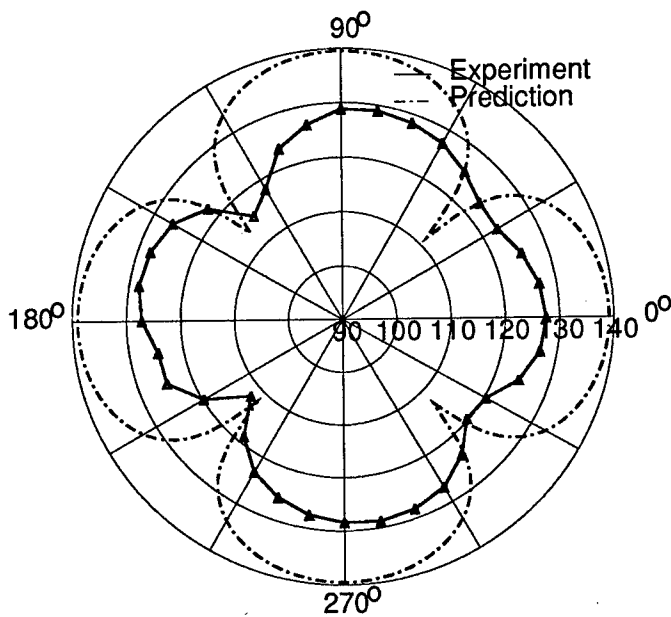

Figure A16: Test 4 - 2,3 Mode

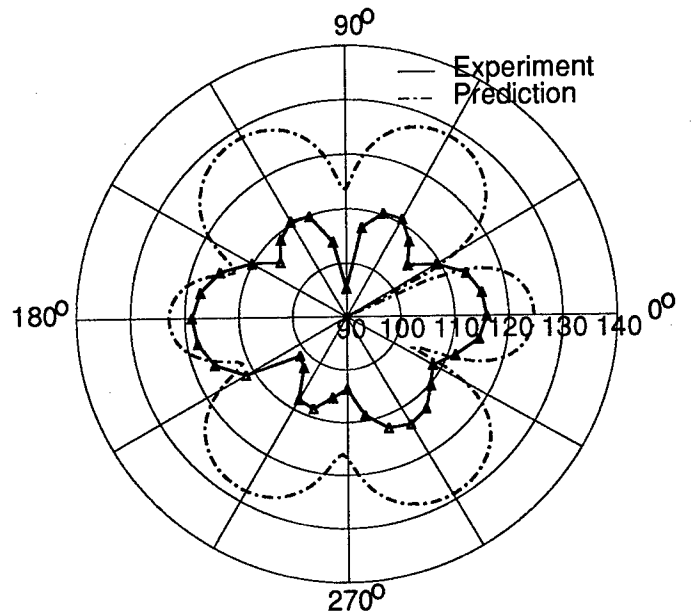

Figure A17: Test 4 - 3,3 Mode

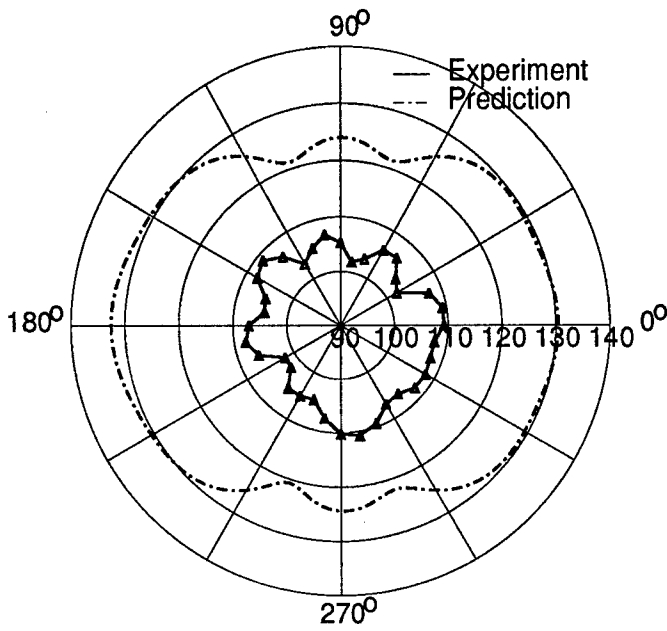

Figure A18: Test 4 - 4,1 Mode

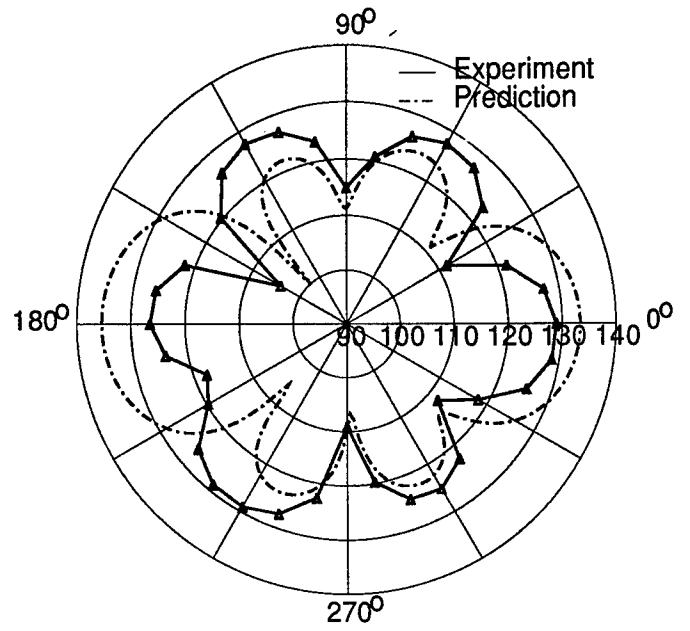

Figure A19: Test 4 - 3,5 Mode

A.1.5 Test 5

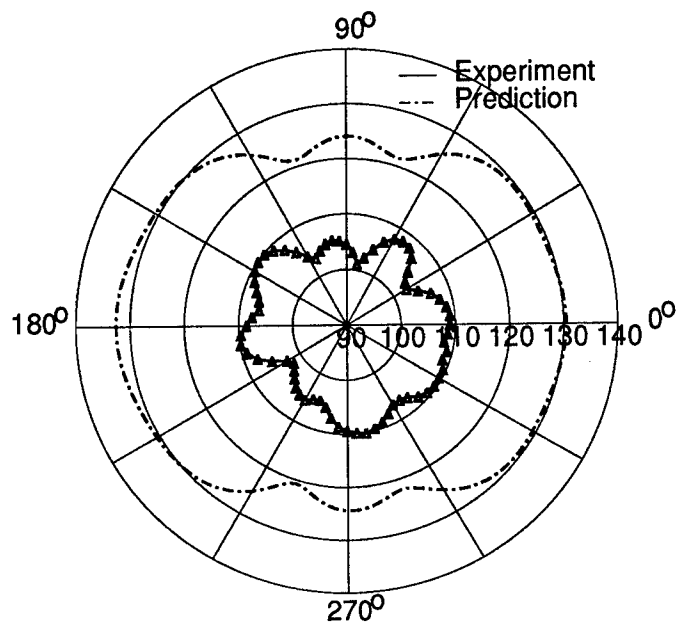

Figure A20: Test 5 - 4,1 Mode

A.1.6: Test 6

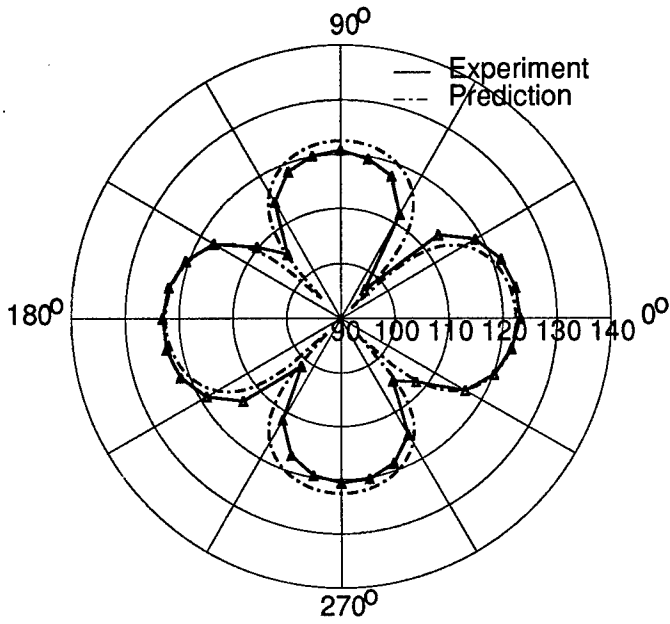

Figure A21: Test 6 - 2,1 Mode

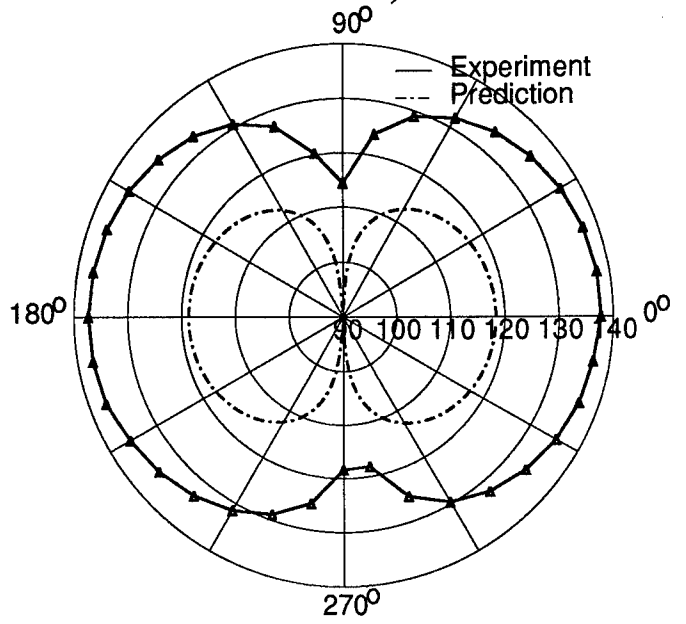

Figure A22: Test 6 - 1,1 Mode

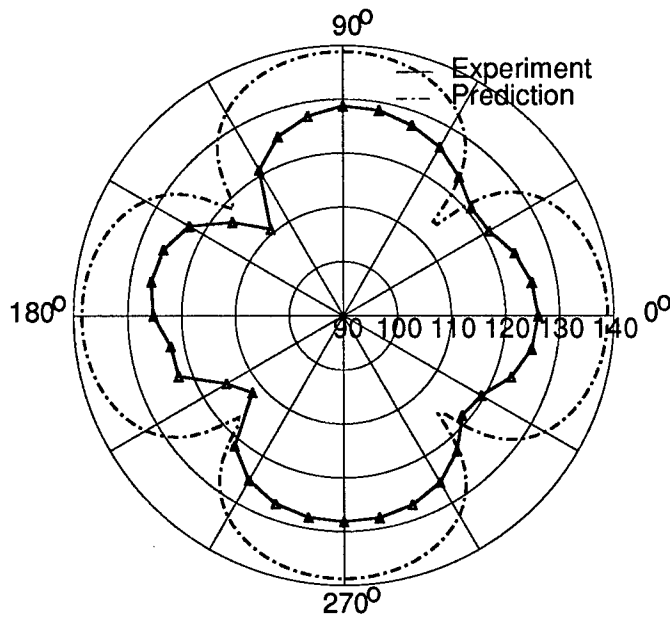

Figure A23: Test 6 - 2,3 Mode

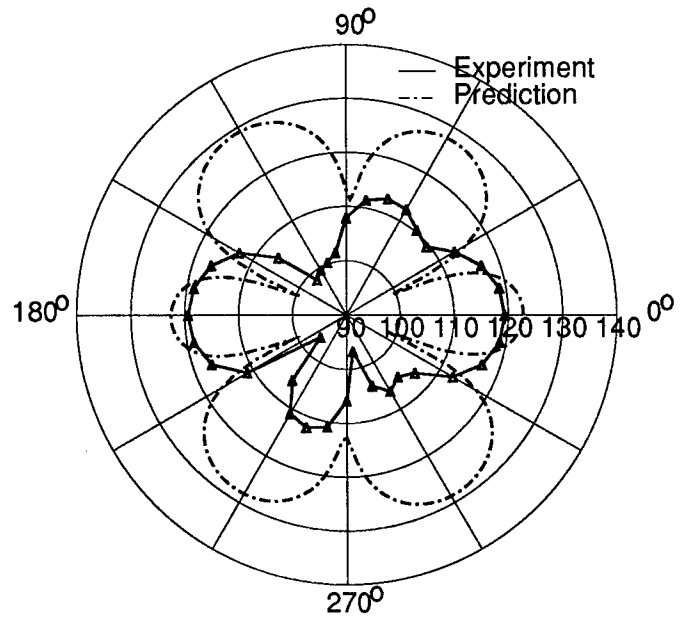

Figure A24: Test 6 - 3,3 Mode

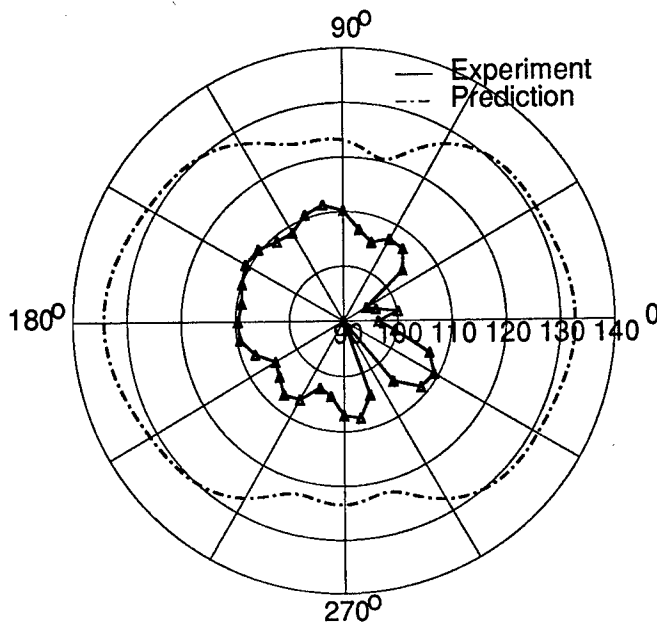

Figure A25: Test 6 - 4,1 Mode

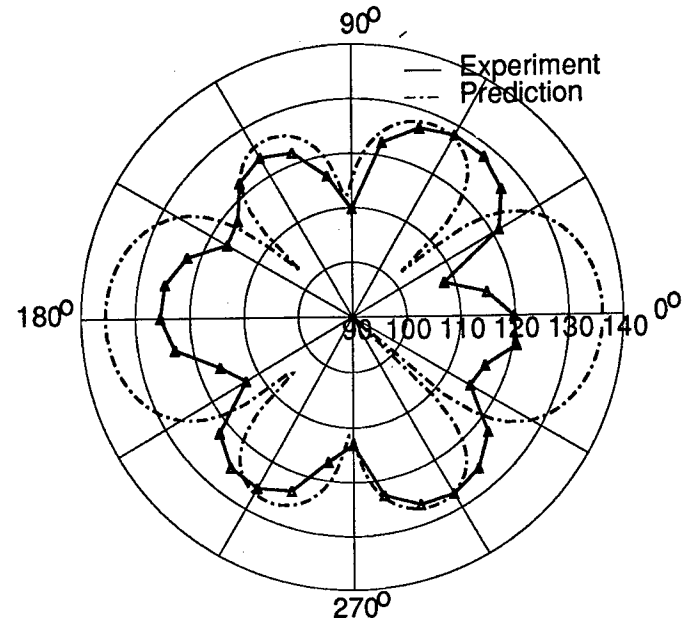

Figure A26: Test 6 - 3,5 Mode

A.1.7: Test 7

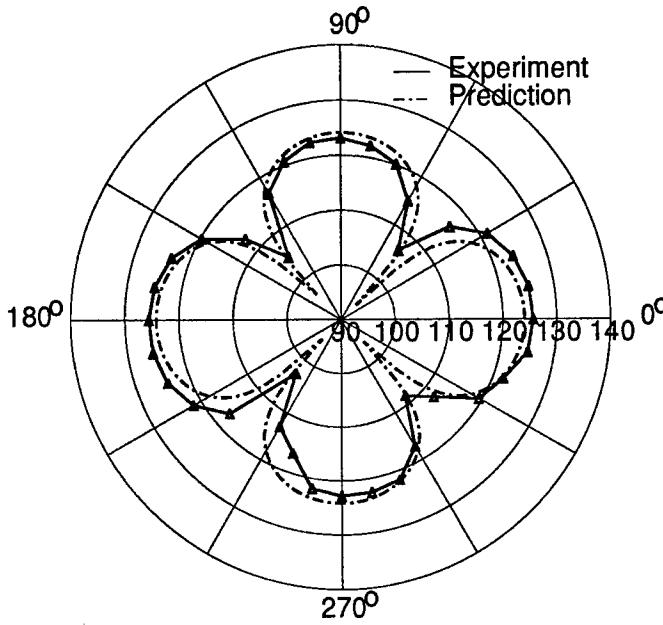

Figure A27: Test 7 - 2,1 Mode

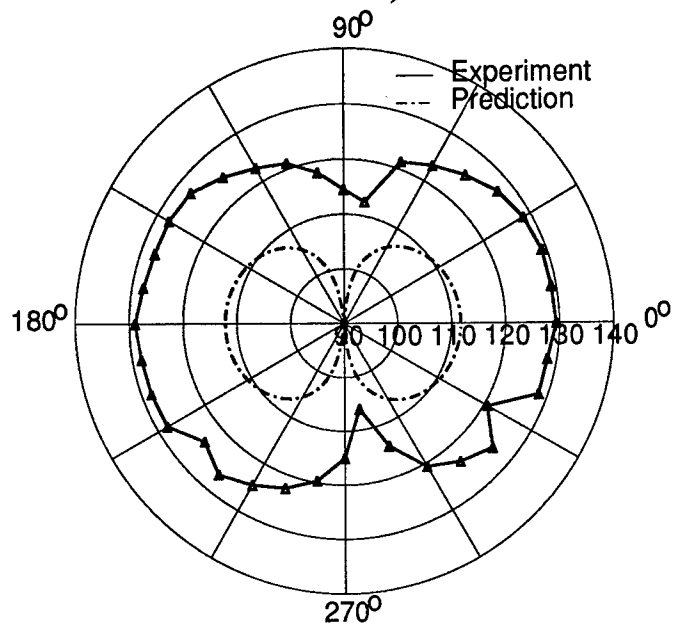

Figure A28: Test 7 - 1,1 Mode

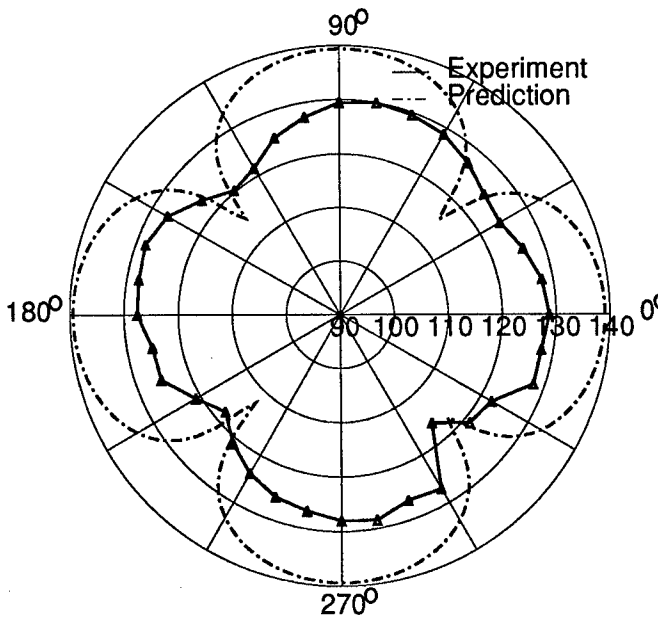

Figure A29: Test 7 - 2,3 Mode

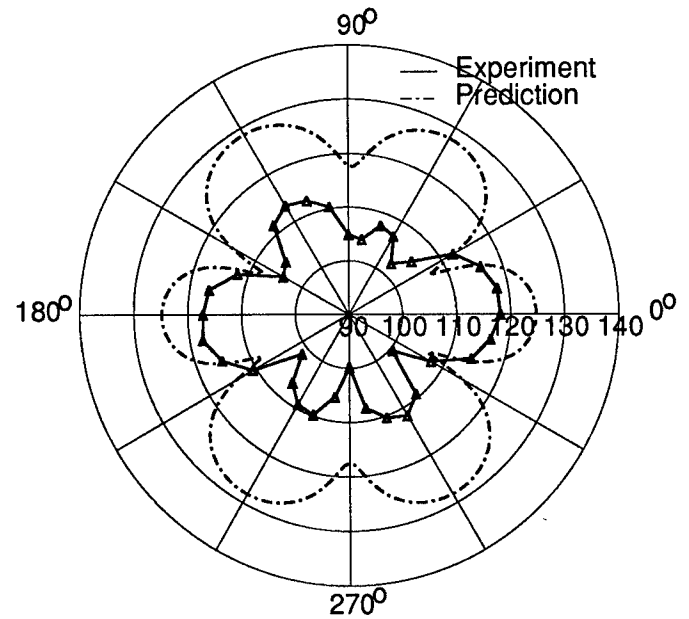

Figure A30: Test 7 - 3,3 Mode

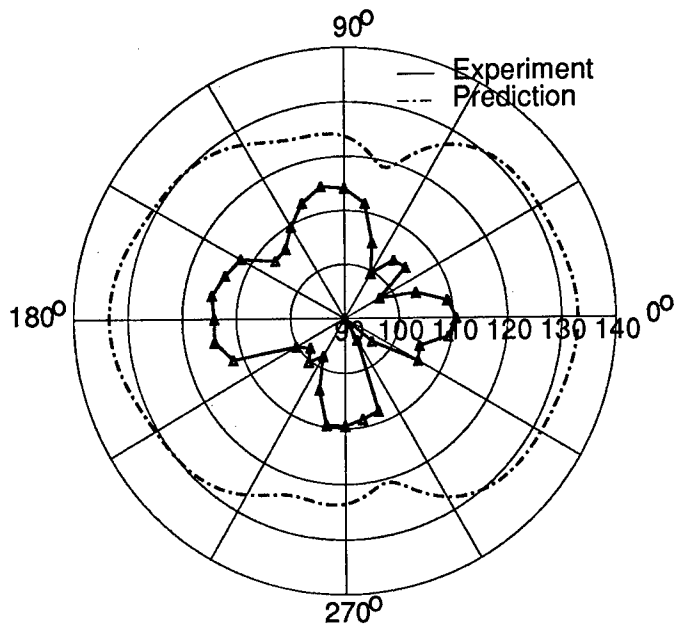

Figure A31: Test 7 - 4,1 Mode

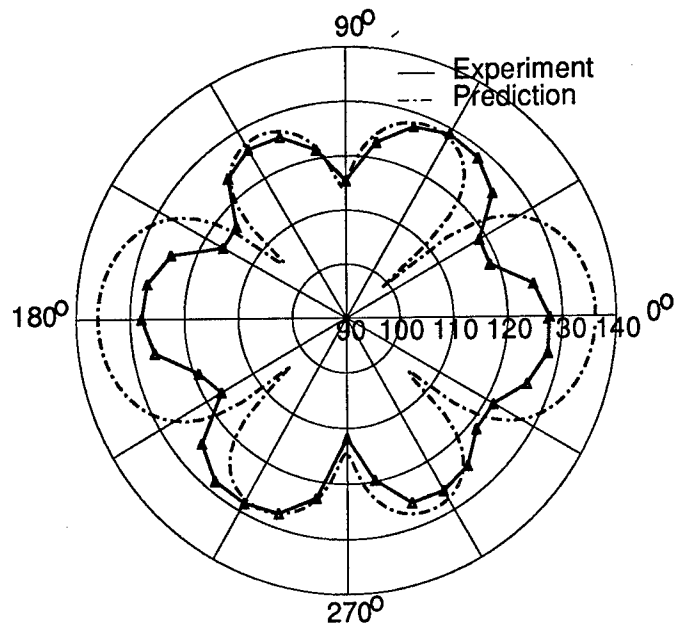

Figure A32: Test 7 - 3,5 Mode

A.1.8: Test 8

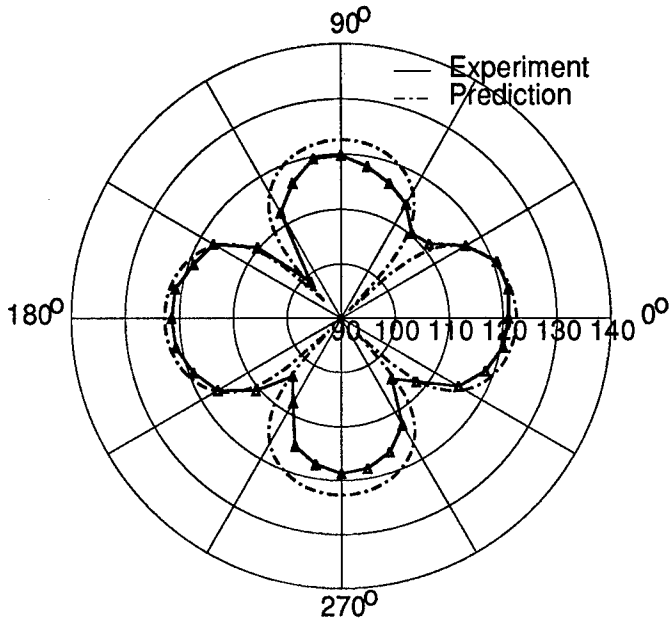

Figure A33: Test 8 - 2,1 Mode

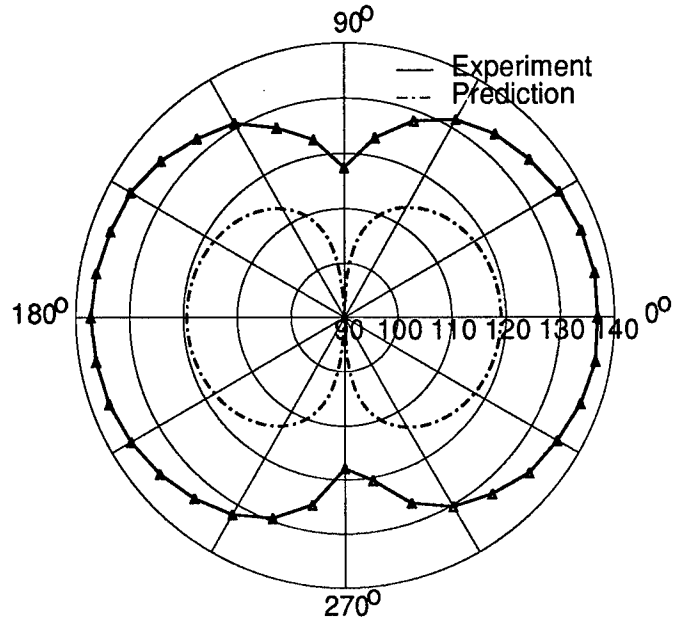

Figure A34: Test 8 - 1,1 Mode

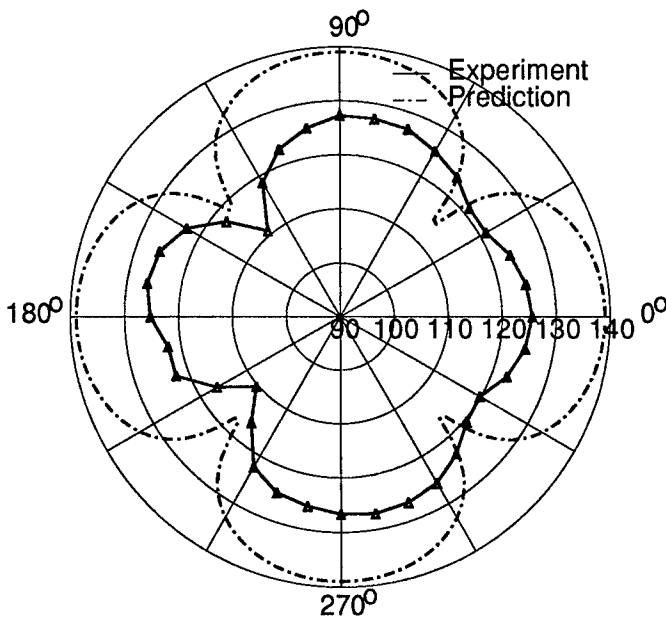

Figure A35: Test 8 - 2,3 Mode

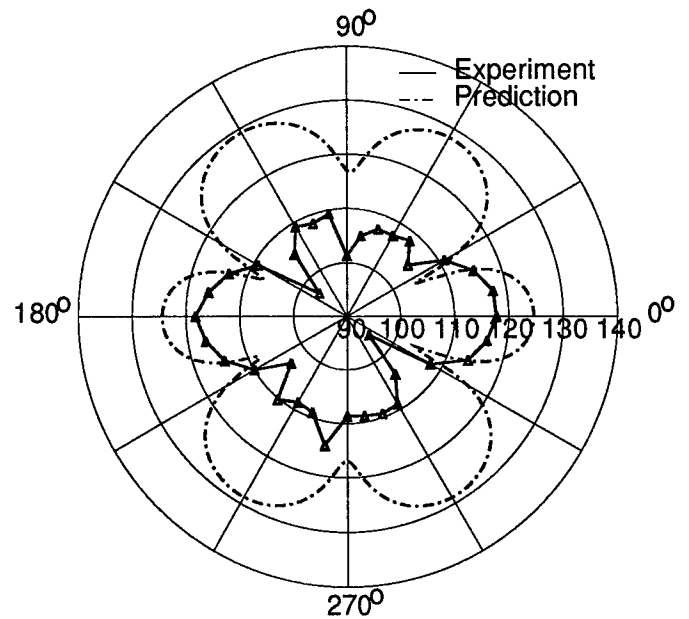

Figure A36: Test 8 - 3,3 Mode

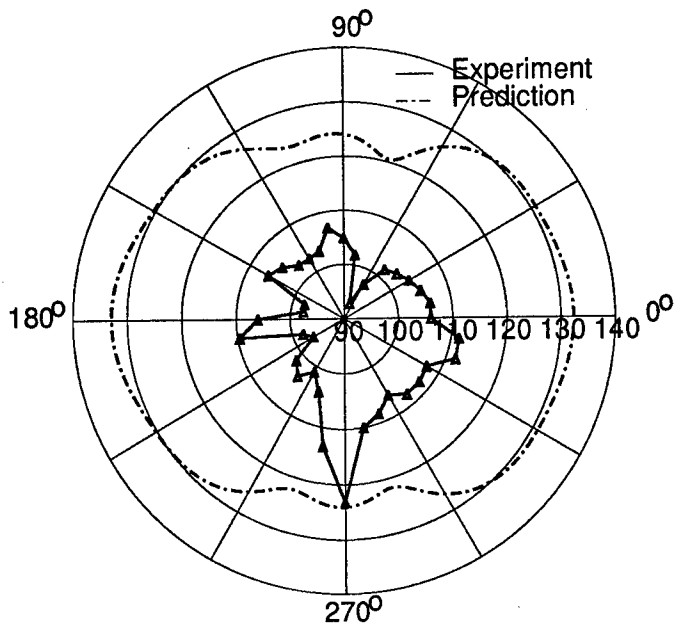

Figure A37: Test 8 - 4,1 Mode

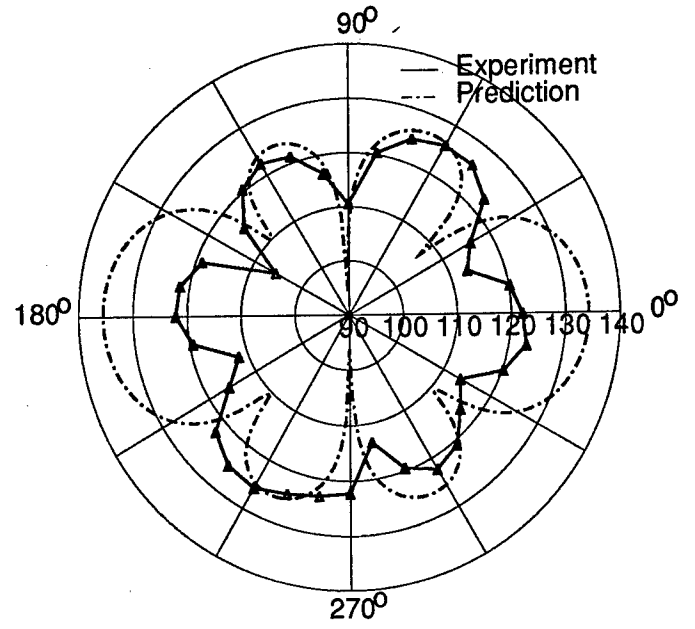

Figure A38: Test 8 - 3,5 Mode

A.2 Horizontal Cylinder

A.2.1 Test 9

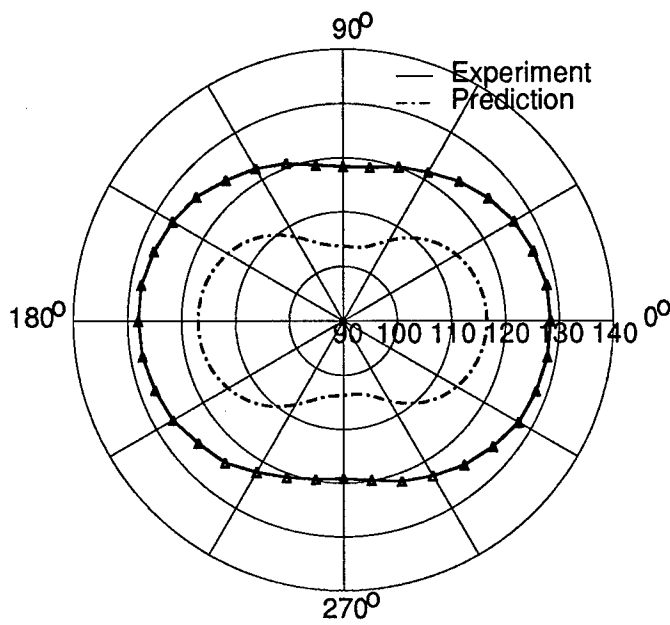

Figure A39: Test 9 - 2,1 Mode

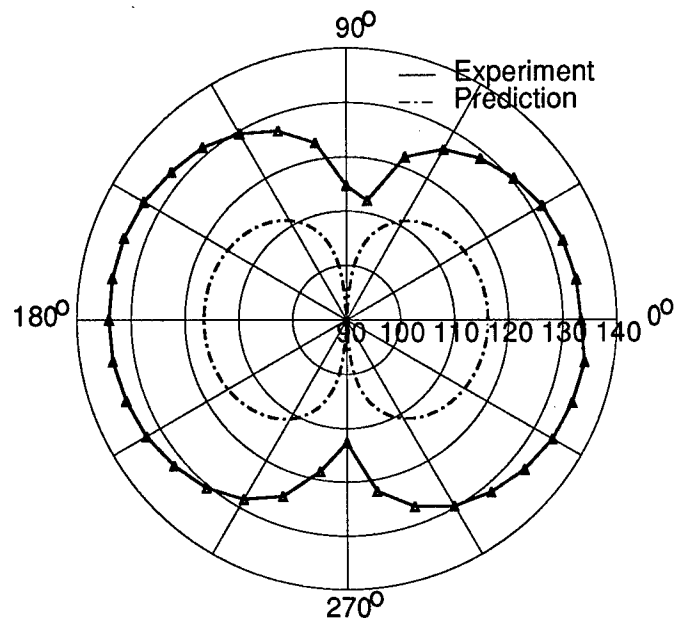

Figure A40: Test 9 - 1,1 Mode

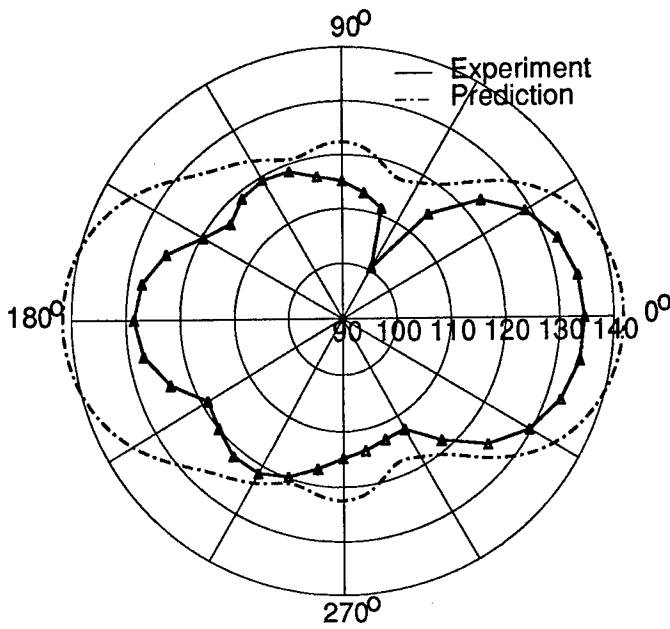

Figure A41: Test 9 - 2,3 Mode

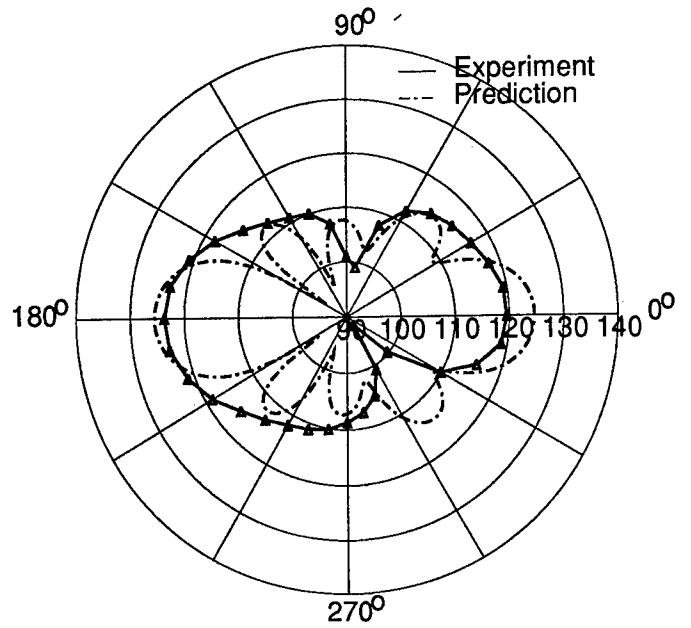

Figure A42: Test 9 - 3,3 Mode

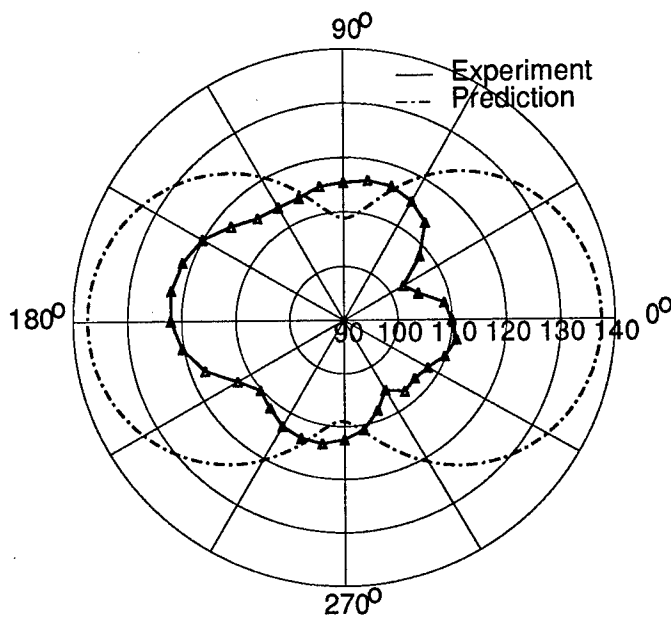

Figure A43: Test 9 - 4,1 Mode

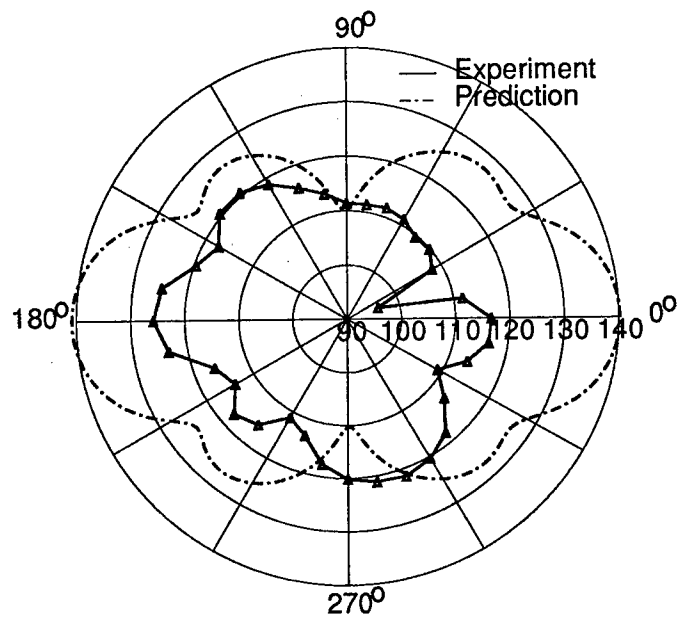

Figure A44: Test 9 - 3,5 Mode

A.2.2: Test 10

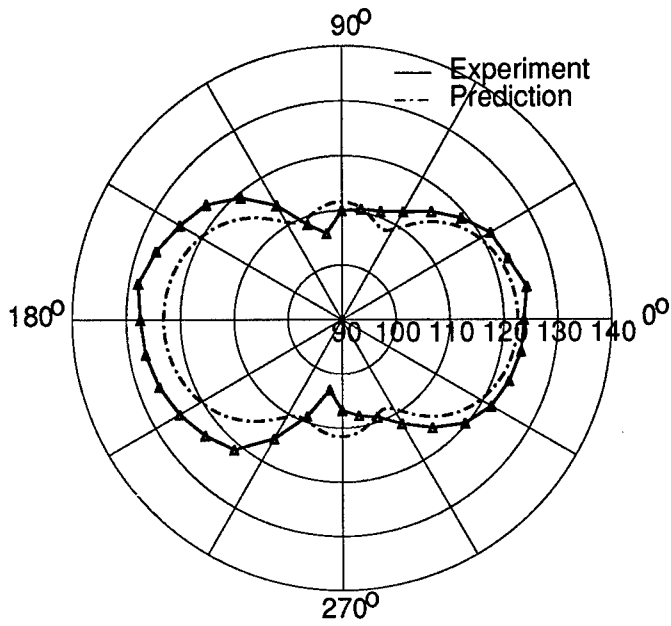

Figure A45: Test 10 - 2,1 Mode

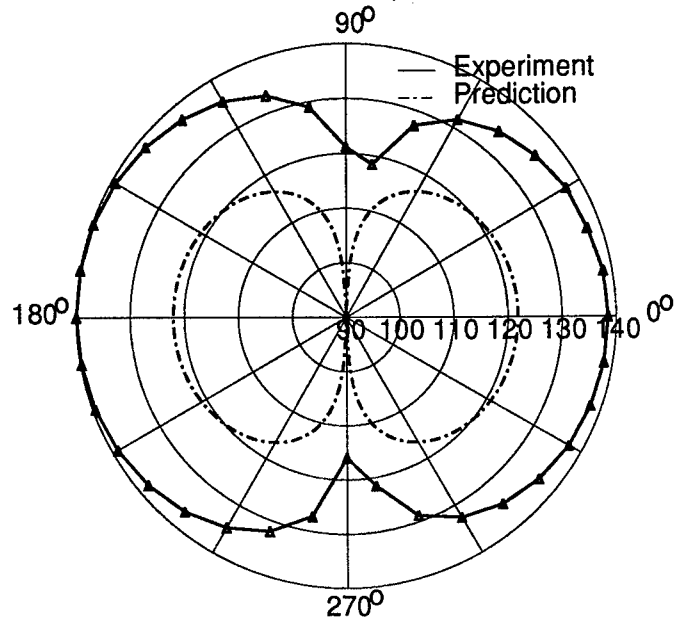

Figure A46: Test 10 - 1,1 Mode

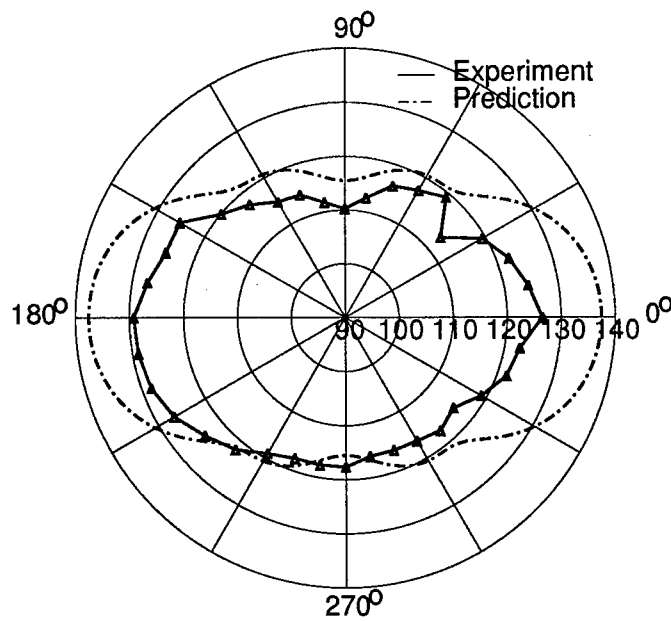

Figure A47: Test 10 - 2,3 Mode

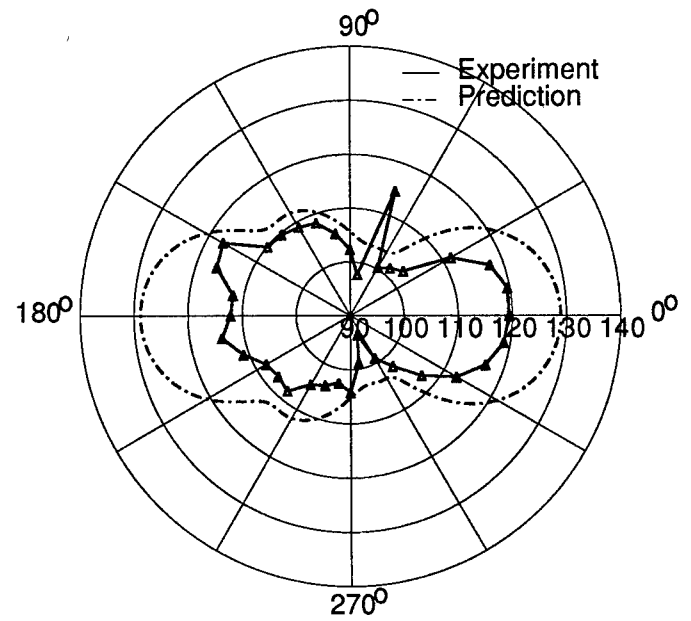
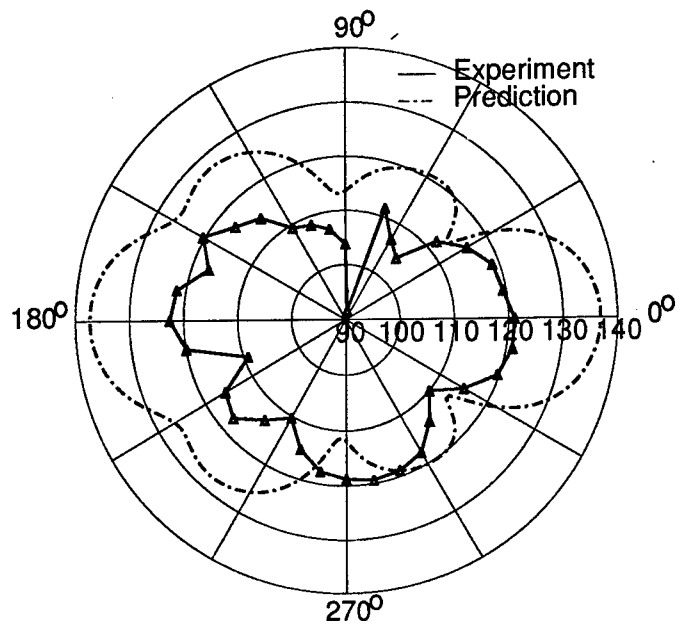
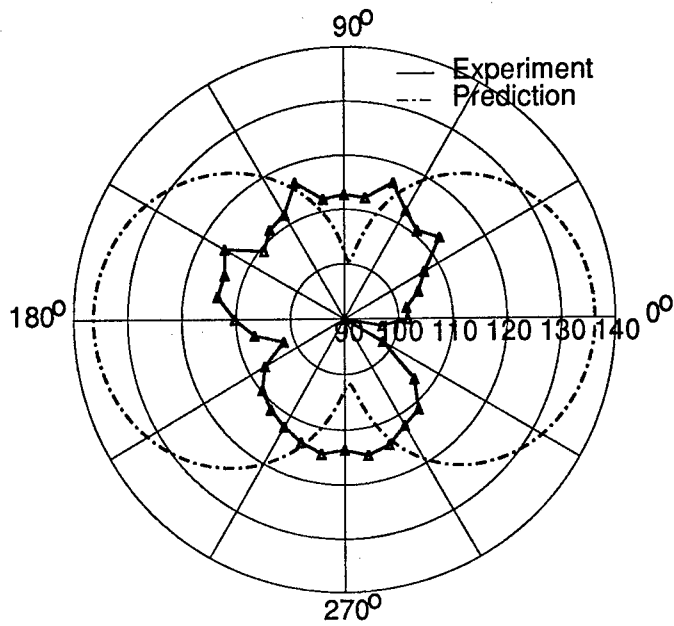

Figure A48: Test 10 - 3,3 Mode



A.2.3: Test 11

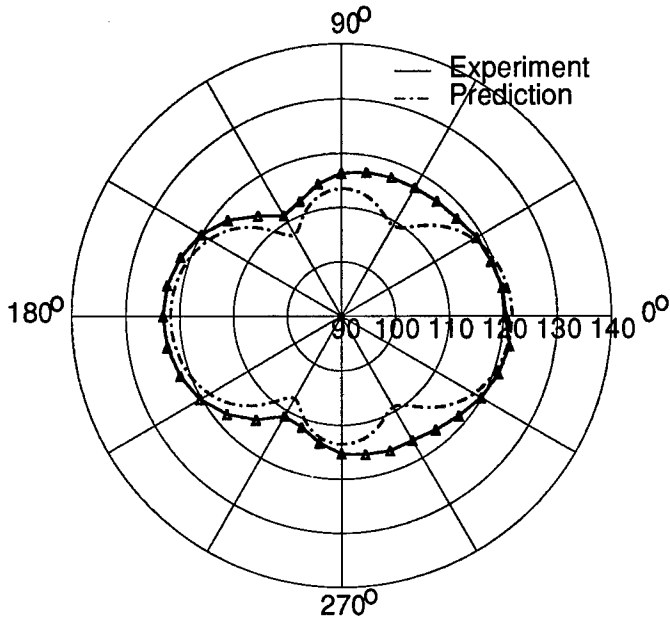

Figure A51: Test 11 - 2,1 Mode

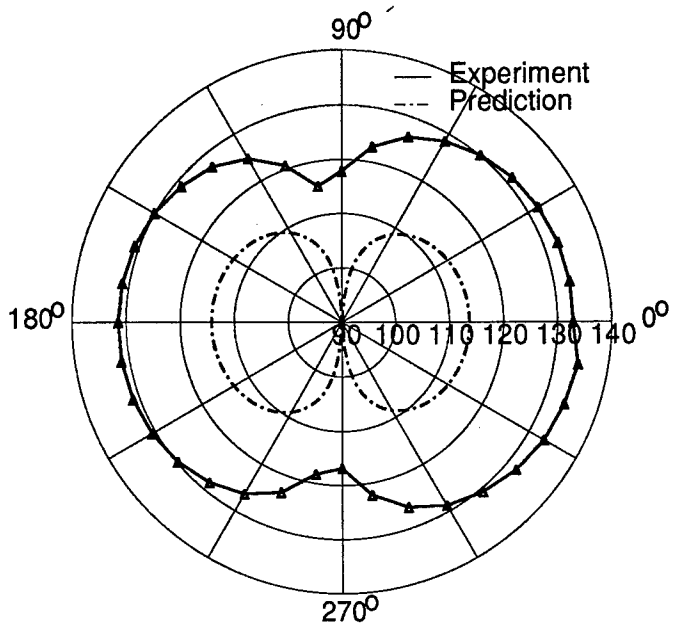

Figure A52: Test 11 - 1,1 Mode

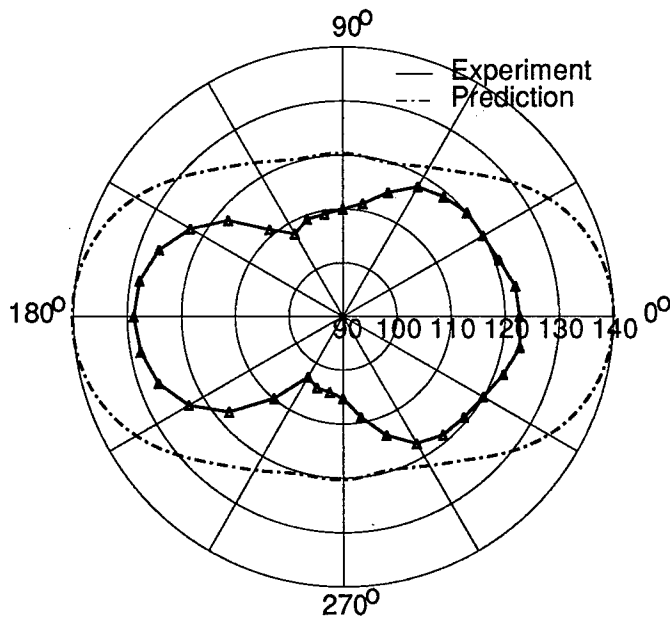

Figure A53: Test 11 - 2,3 Mode

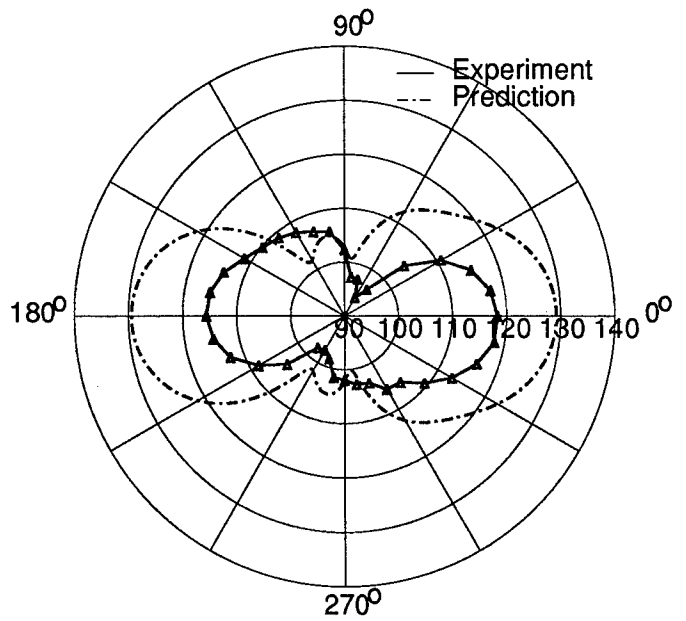

Figure A54: Test 11 - 3,3 Mode

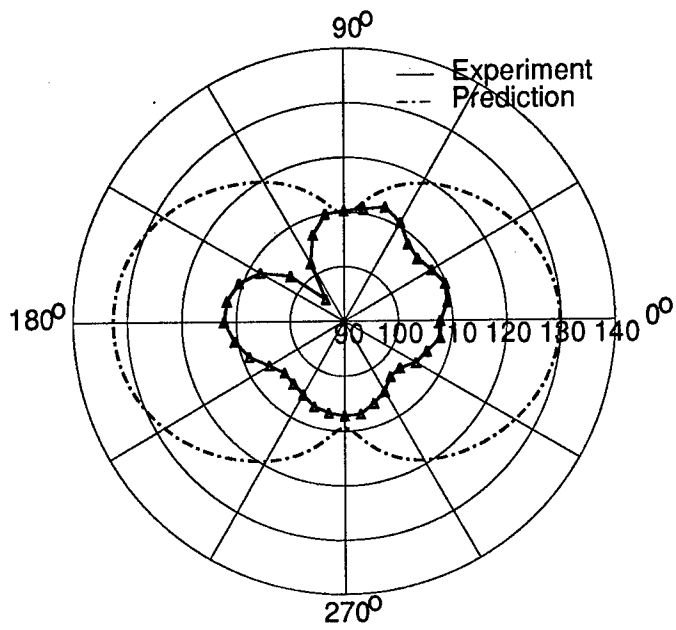

Figure A55: Test 11 - 4,1 Mode

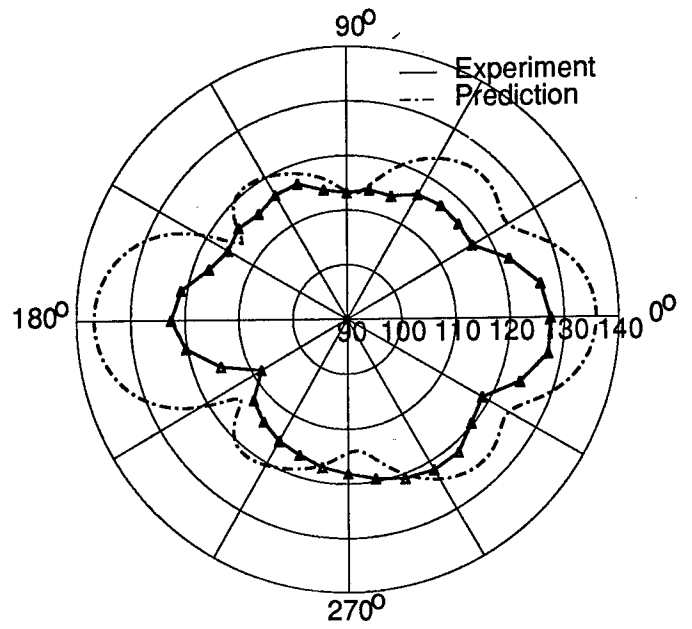

Figure A56: Test 11 - 3,5 Mode

A.2.4: Test 12

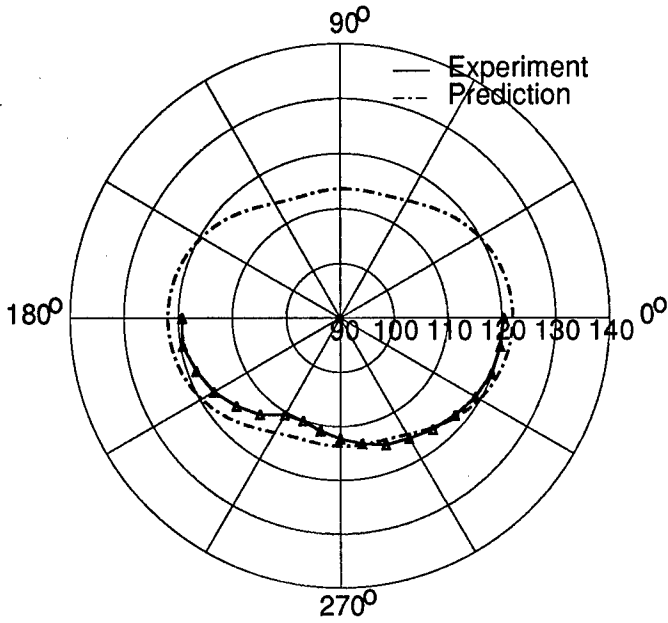

Figure A57: Test 12 - 2,1 Mode

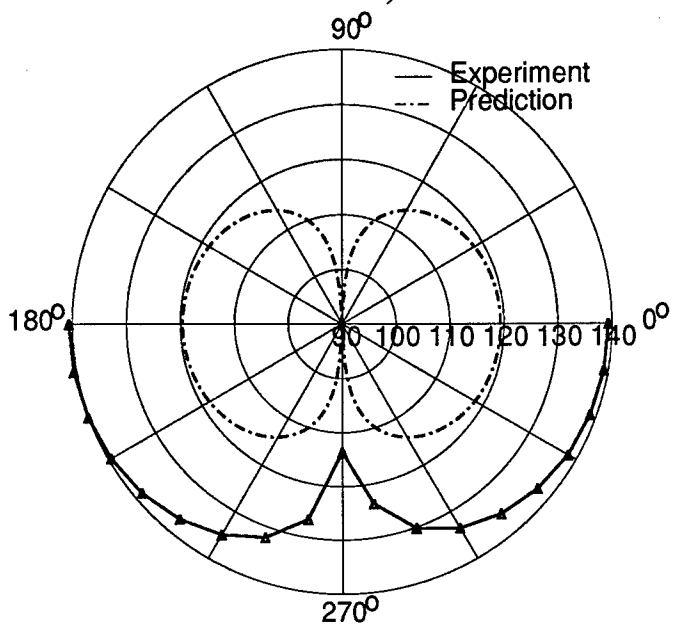

Figure A58: Test 12 - 1,1 Mode

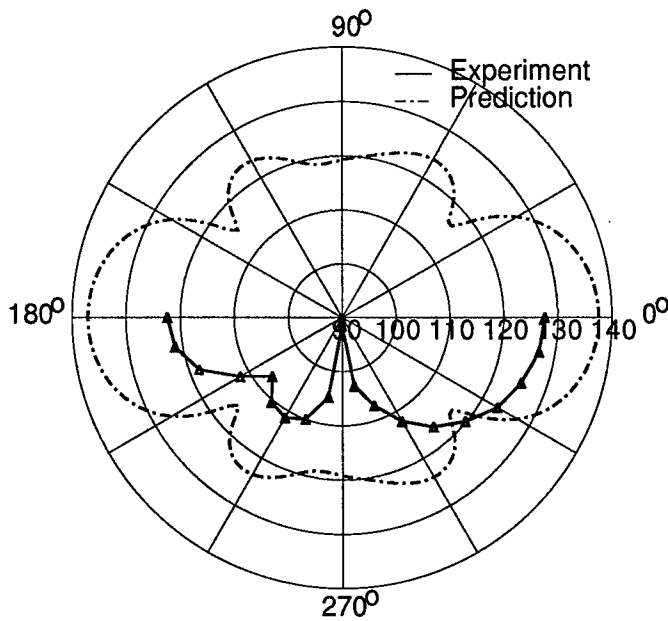

Figure A59: Test 12 - 2,3 Mode

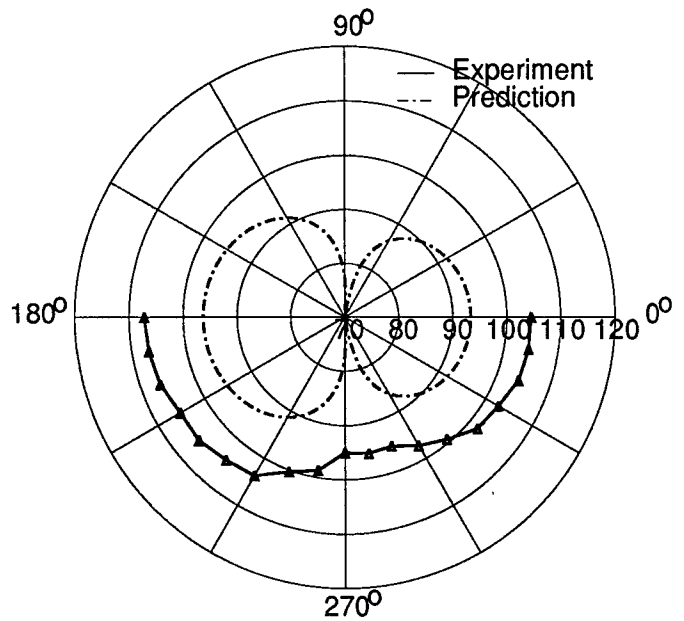

Figure A60: Test 12 - 250 Hz

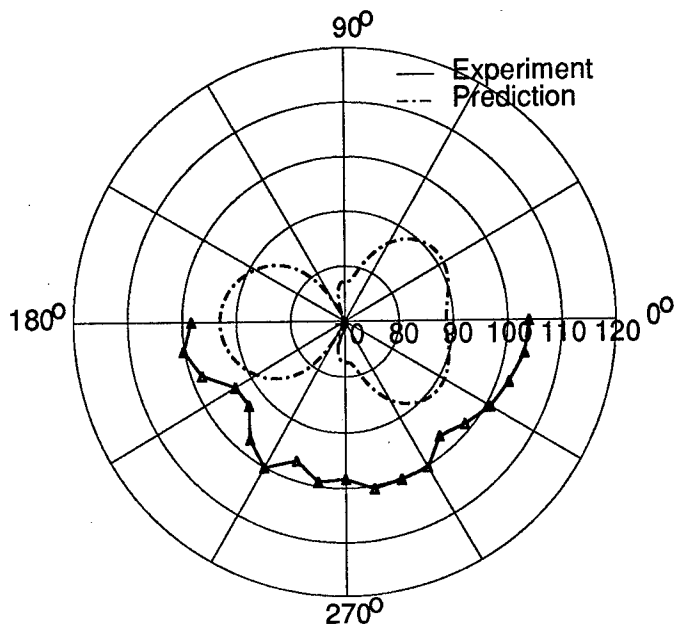

Figure A61: Test 12 - 400 Hz

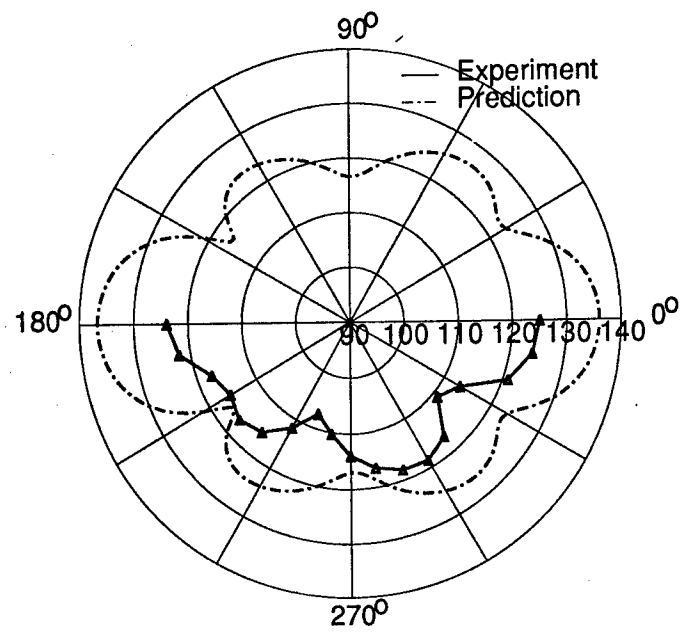

Figure A62: Test 12 - 3,5 Mode

A.2.5: Test 13

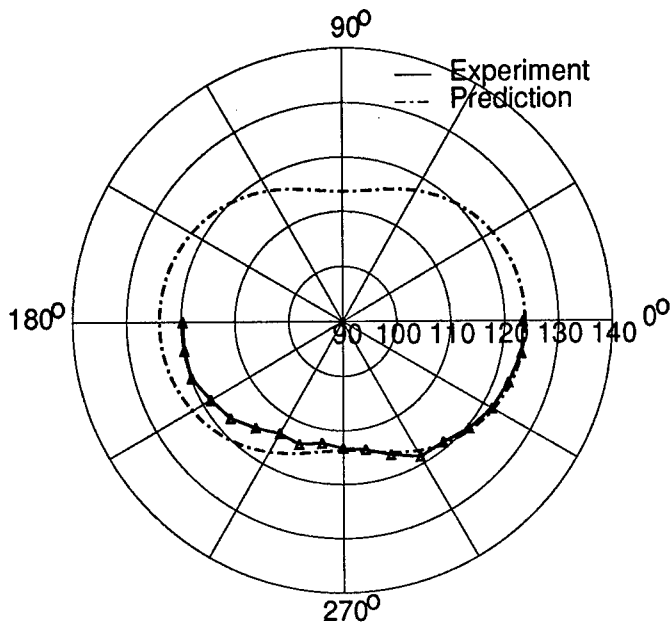

Figure A63: Test 13 - 2,1 Mode

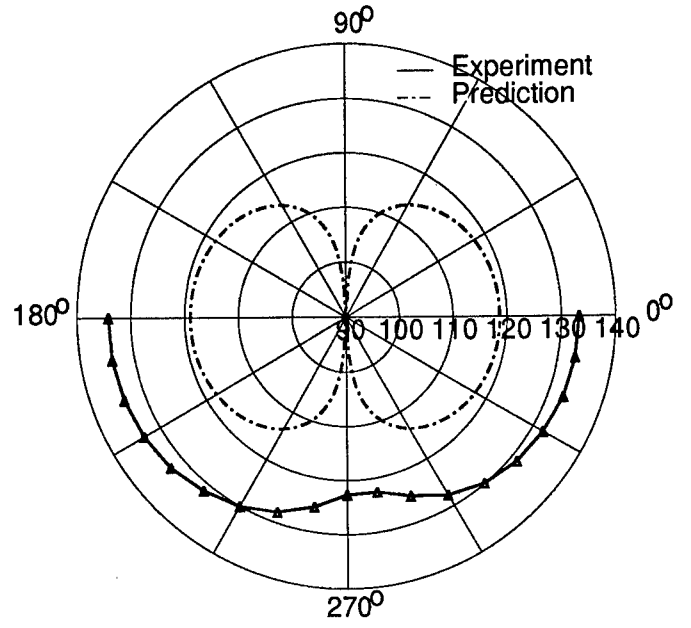

Figure A64: Test 13 - 1,1 Mode

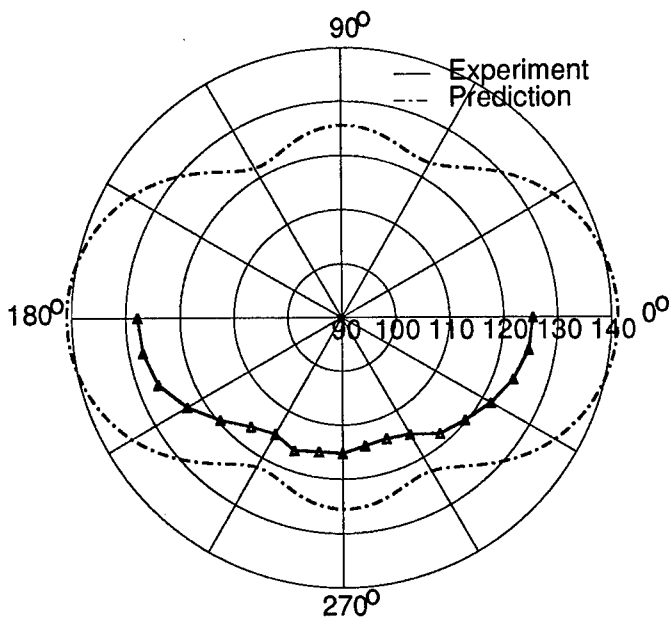

Figure A65: Test 13 - 2,3 Mode

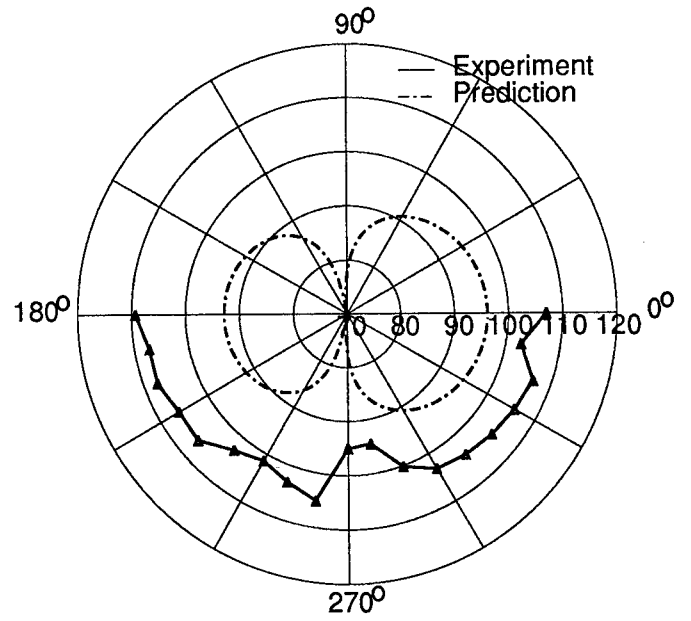

Figure A66: Test 13 - 250 Hz

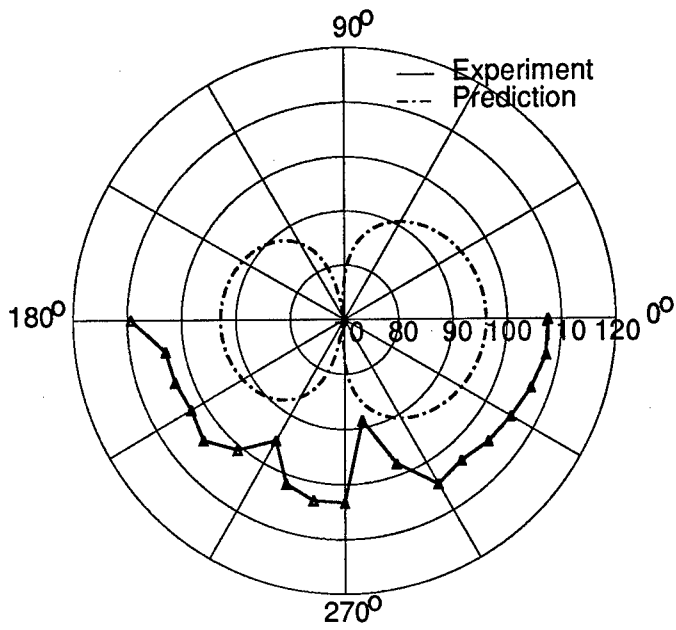

Figure A67: Test 13 - 400 Hz

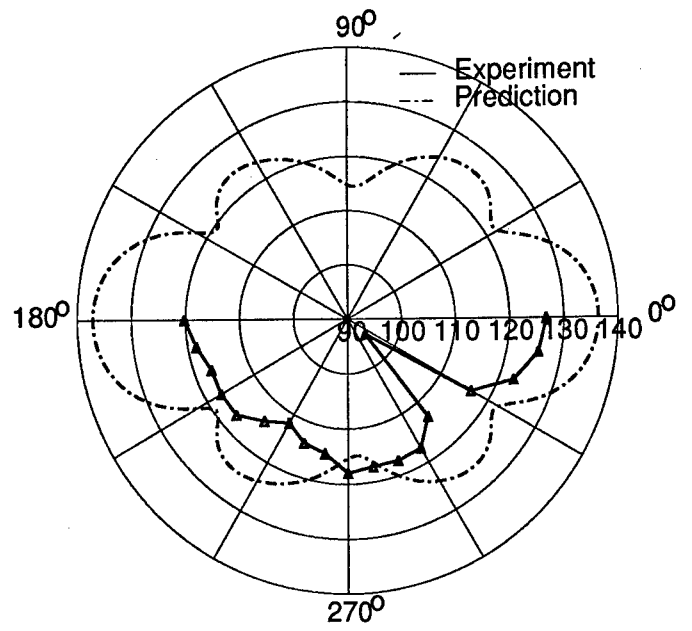

Figure A68: Test 13 - 3,5 Mode

A.2.6: Test 14

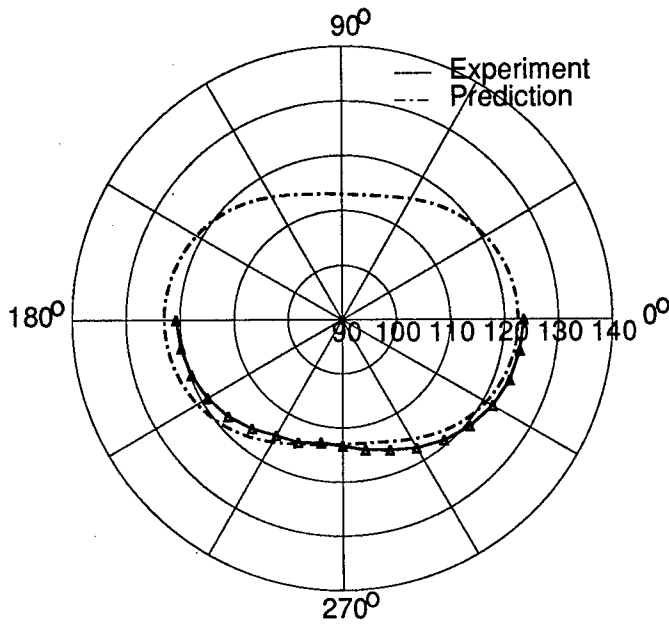

Figure A69: Test 14 - 2,1 Mode

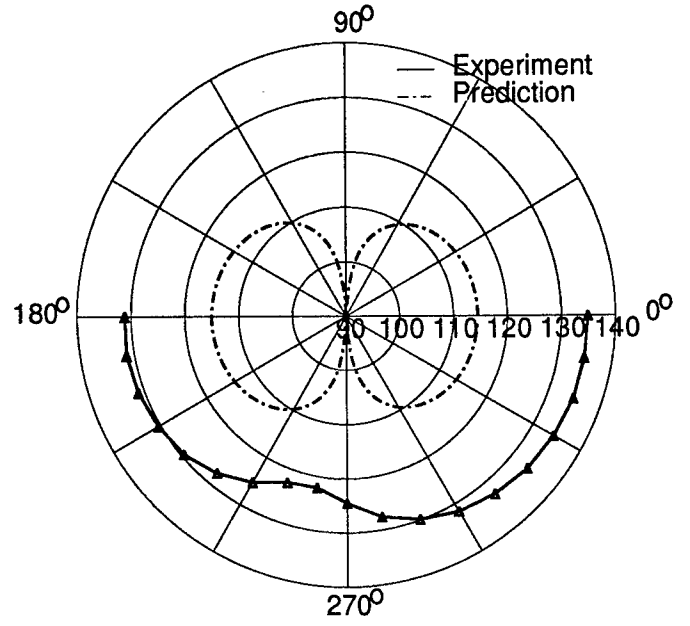

Figure A70: Test 14 - 1,1 Mode

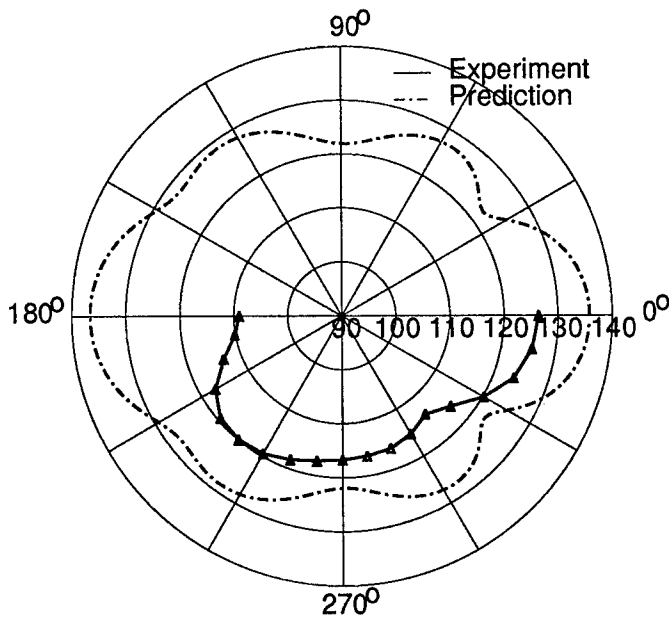

Figure A71: Test 14 - 2,3 Mode

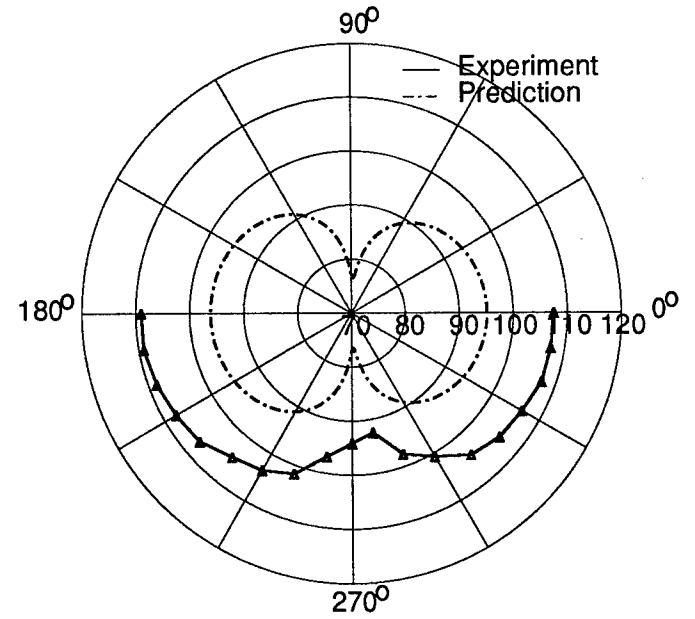

Figure A72: Test 14 - 250 Hz

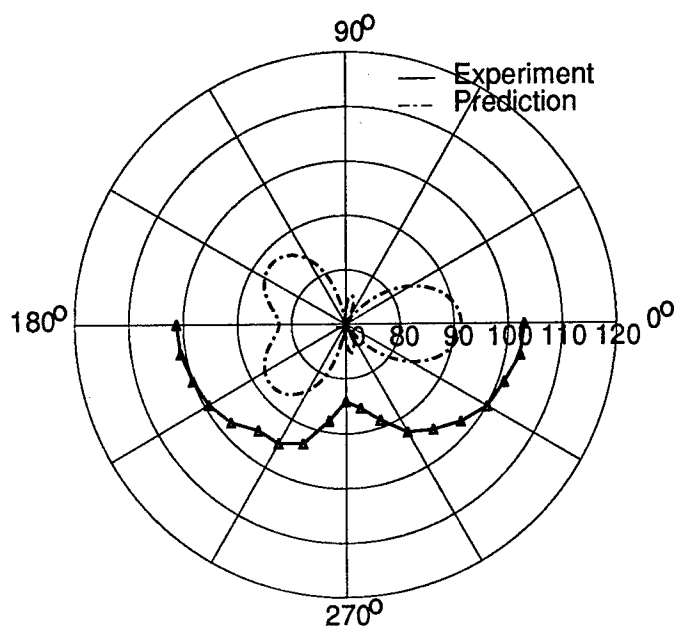

Figure A73: Test 14 - 400 Hz

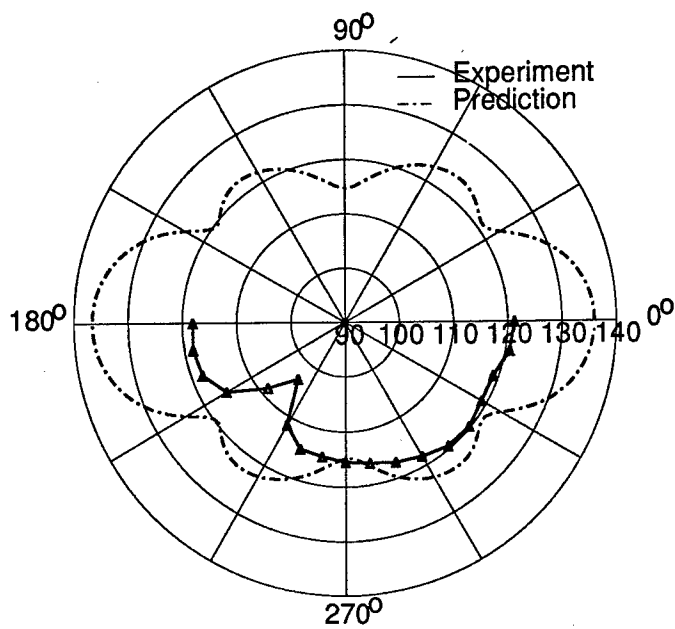

Figure A74: Test 14 - 3,5 Mode

B Directivity Plots - 1994

B.1 Vertical Cylinder

B.1.1 Test 3

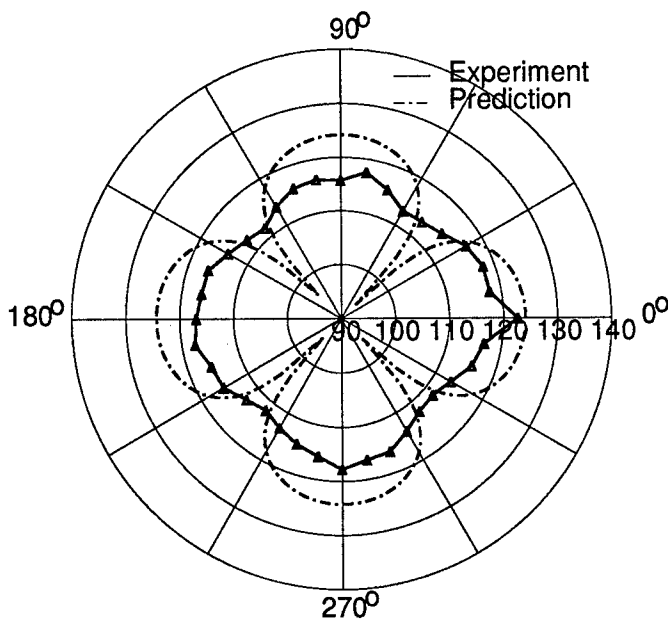

Figure B1: Test 3 - 2,1 Mode

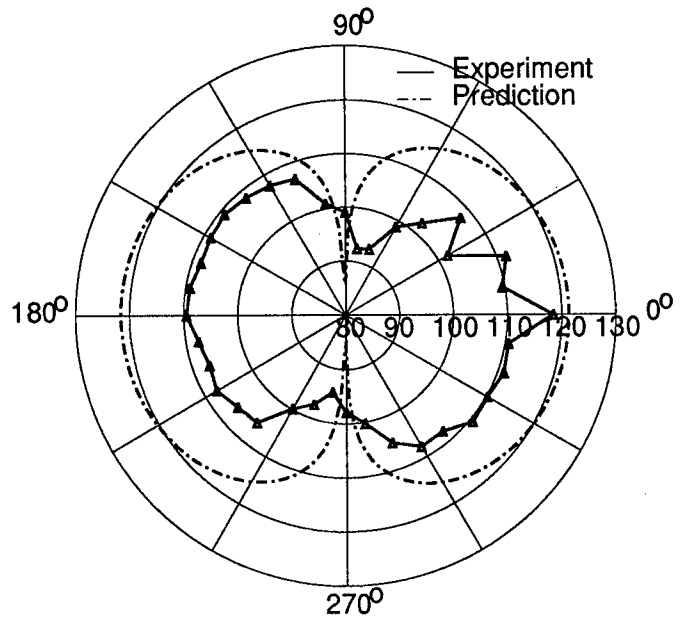

Figure B2: Test 3 - 1,1 Mode

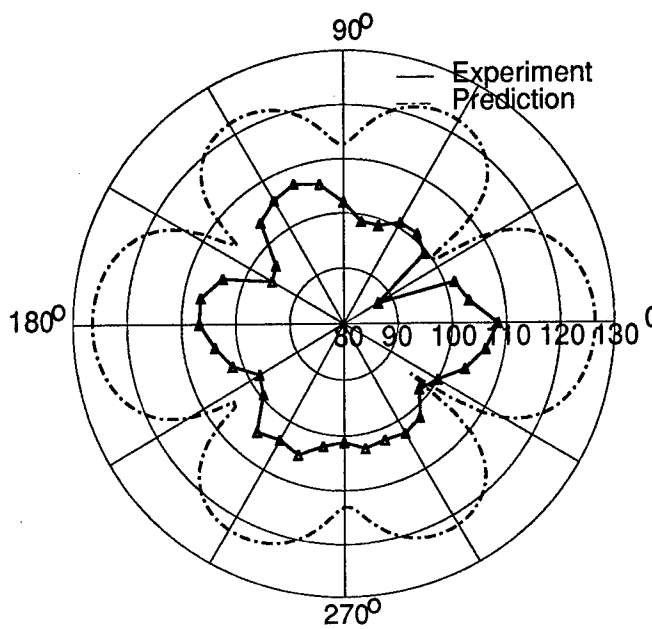

Figure B3: Test 3 - 3,1 Mode

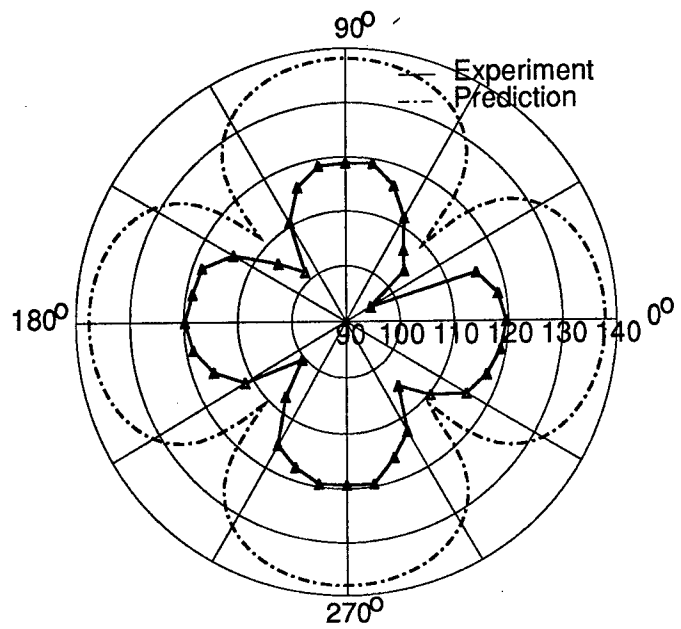

Figure B4: Test 3 - 2,3 Mode

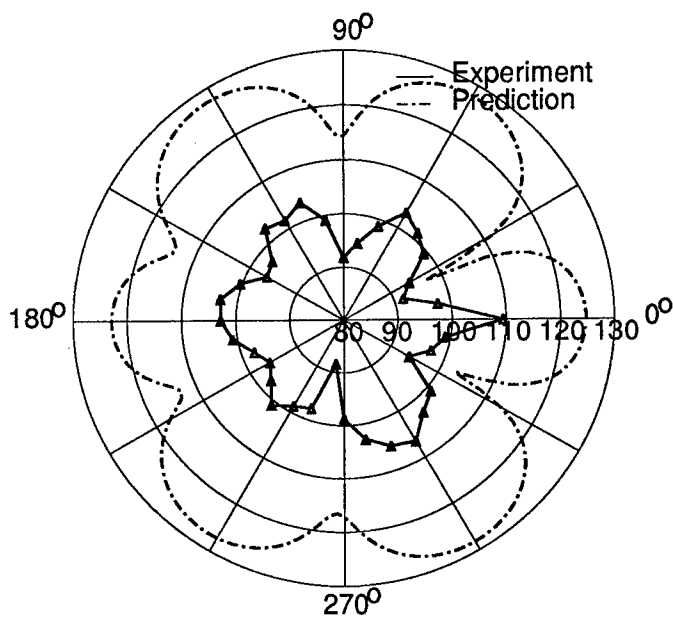

Figure B5: Test 3 - 3,3 Mode

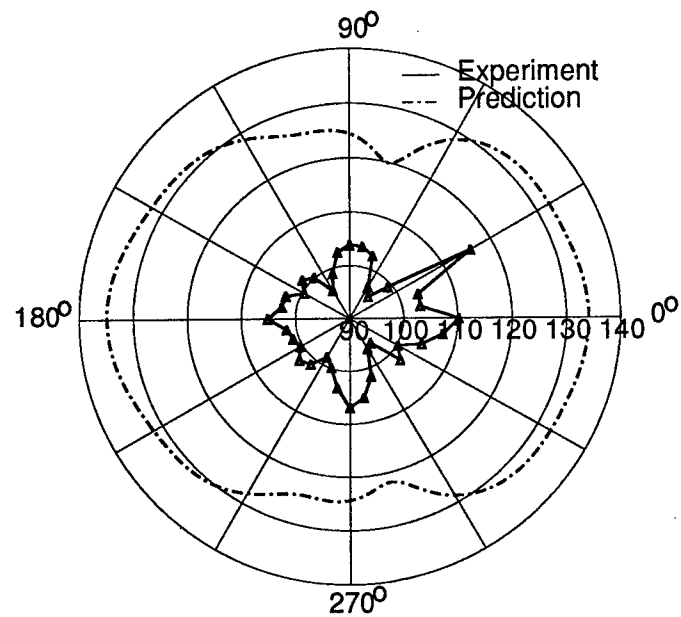

Figure B6: Test 3 - 4,1 Mode

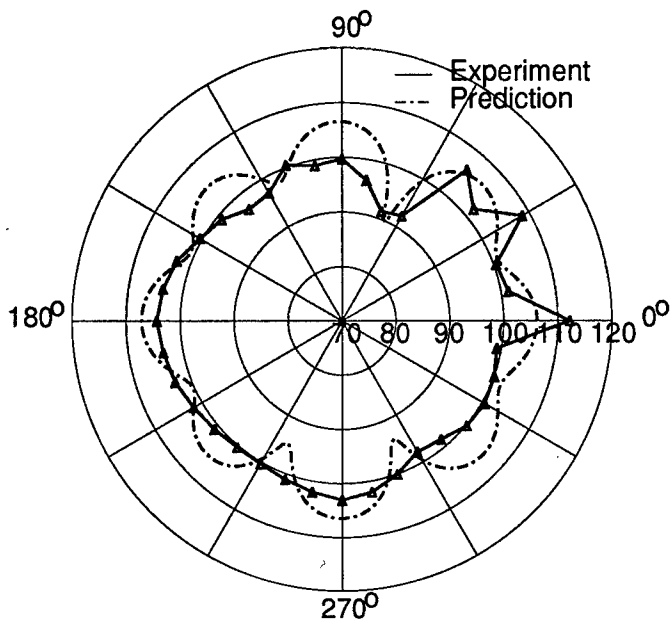

Figure B7: Test 3 - 4,1 Mode

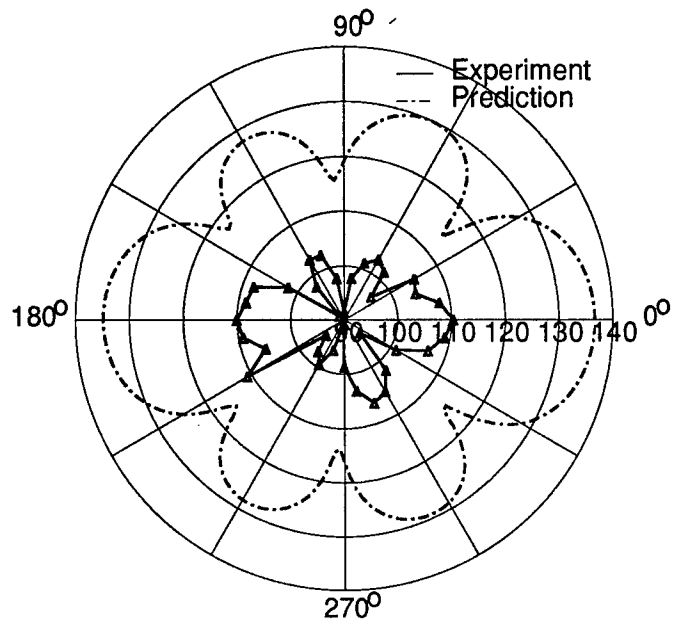

Figure B8: Test 3 - 3,5 Mode

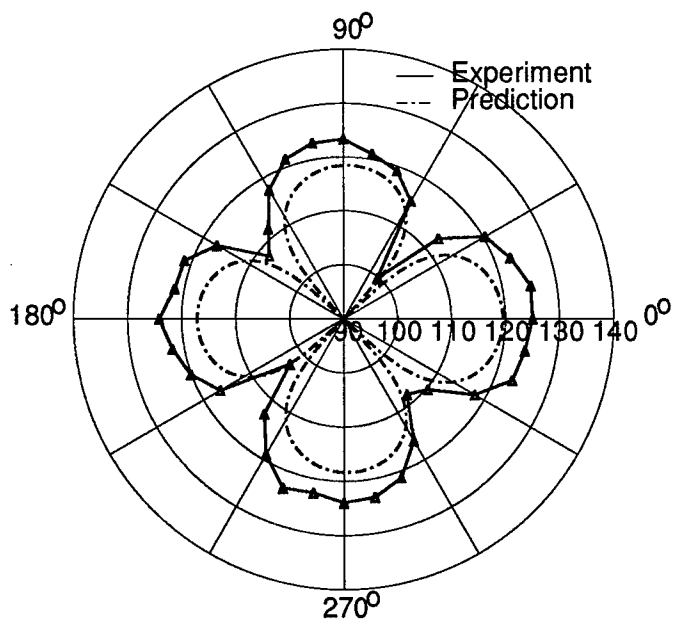

Figure B9: Test 3 - 2,5 Mode

B.1.2: Test 4

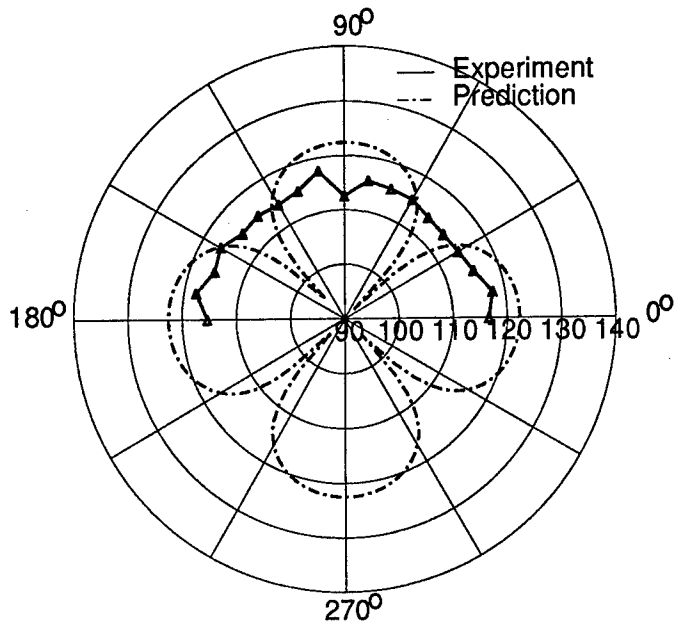

Figure B10: Test 4 - 2,1 Mode

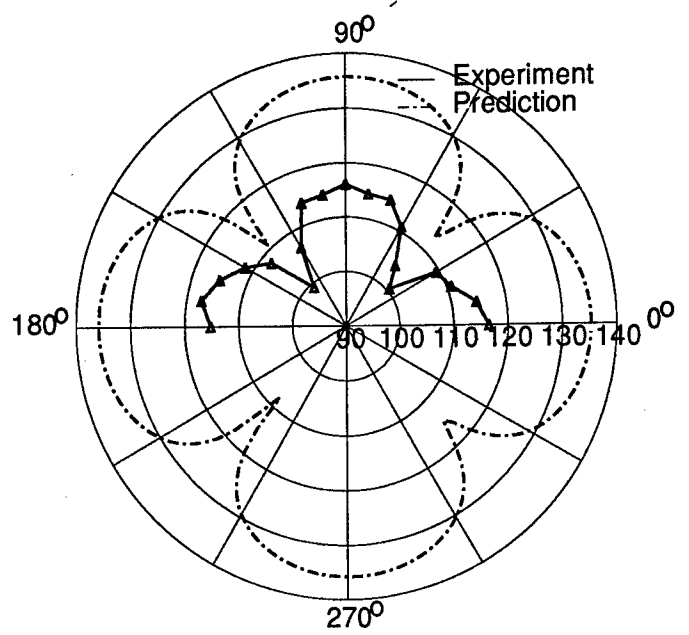

Figure B11: Test 4 - 2,3 Mode

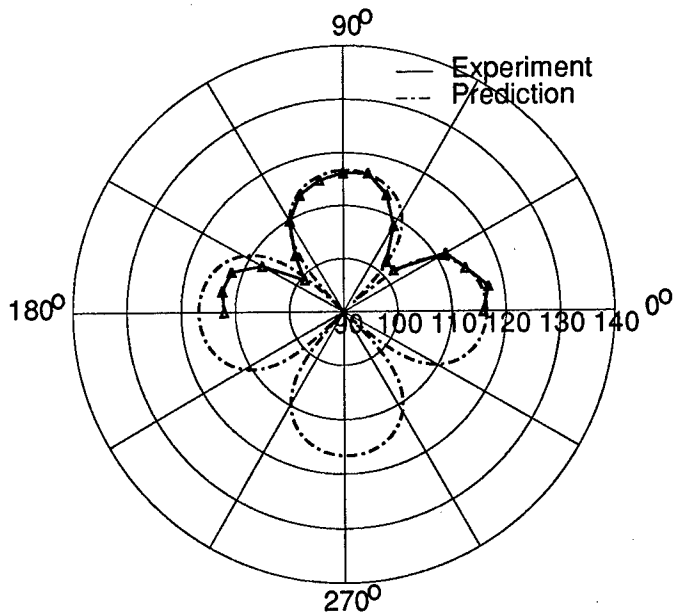

Figure B12: Test 4 - 2,5 Mode

B.1.3: Test 5

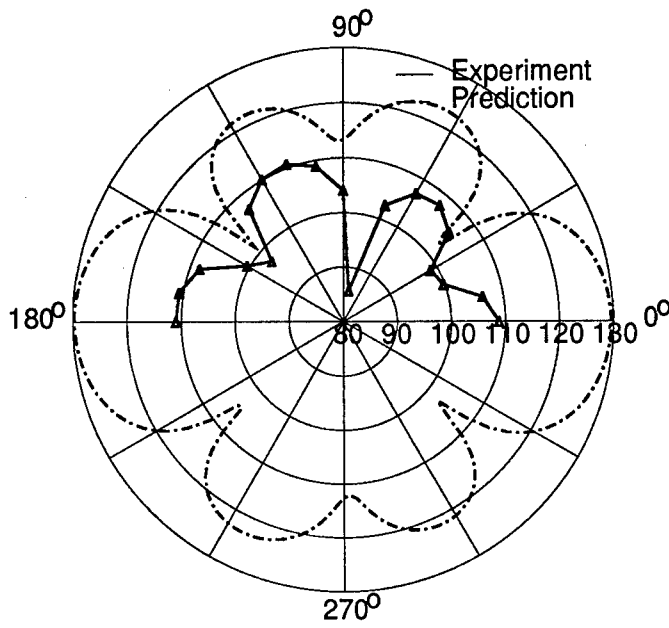

Figure B13: Test 5 - 3,1 Mode

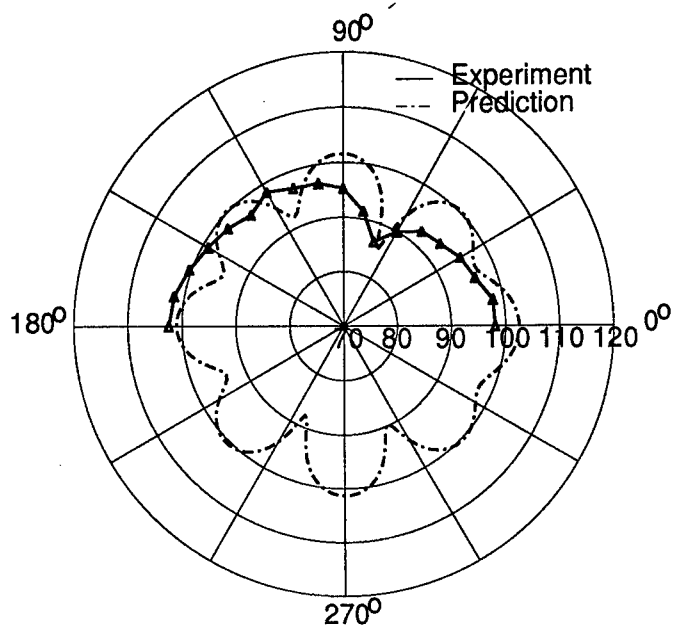

Figure B14: Test 5 - 4,1 Mode

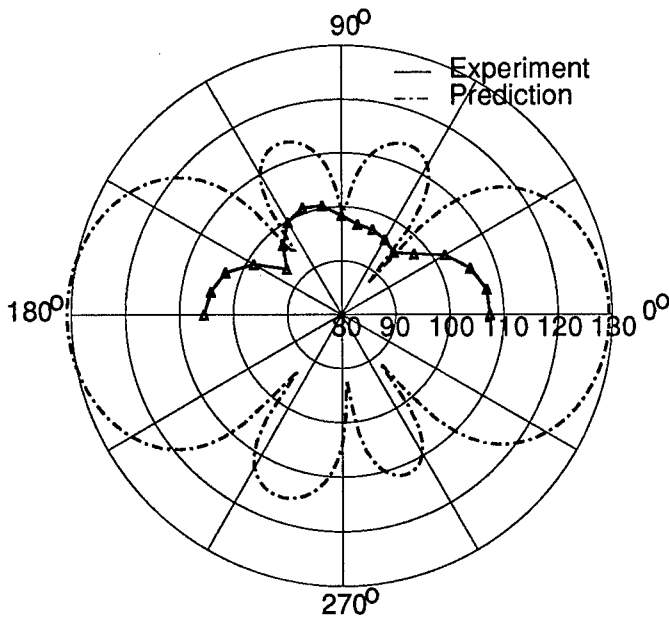

Figure B15: Test 5 - 3,5 Mode

B.1.4: Test 6

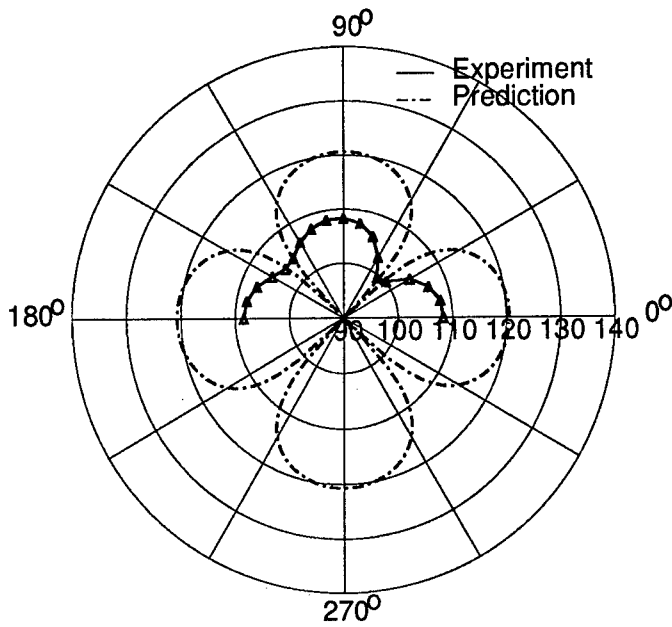

Figure B16: Test 6 - 2,1 Mode

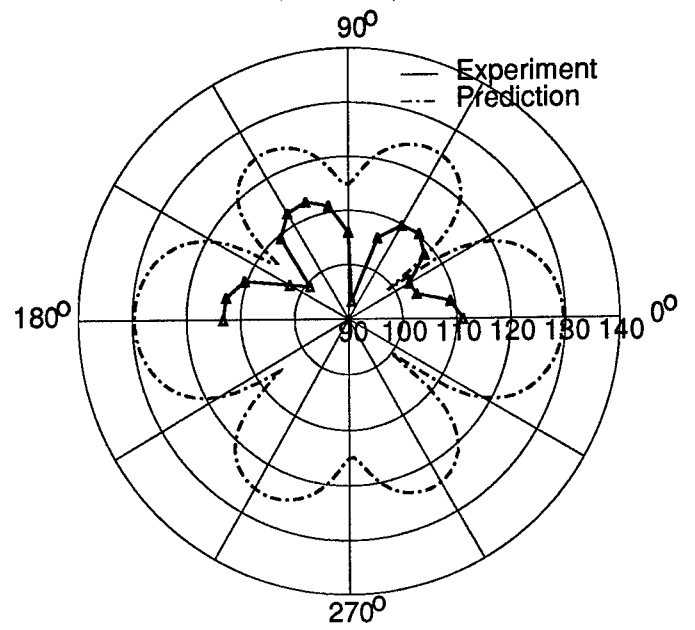

Figure B17: Test 6 - 3,1 Mode

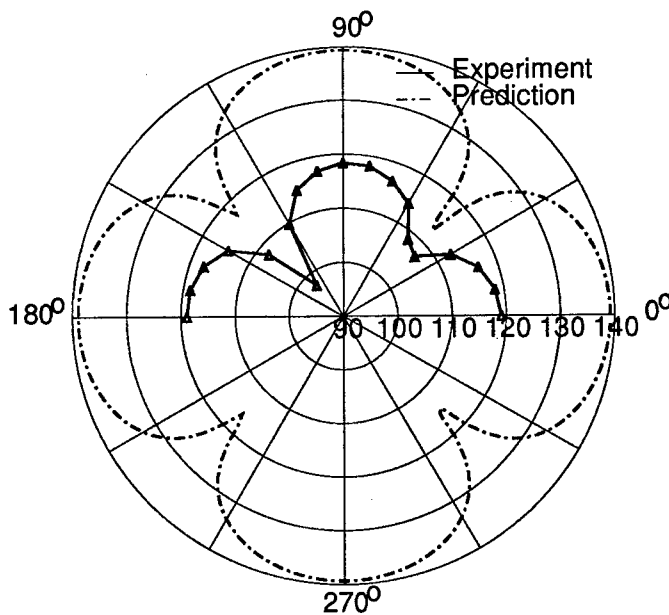

Figure B18: Test 6 - 2,3 Mode

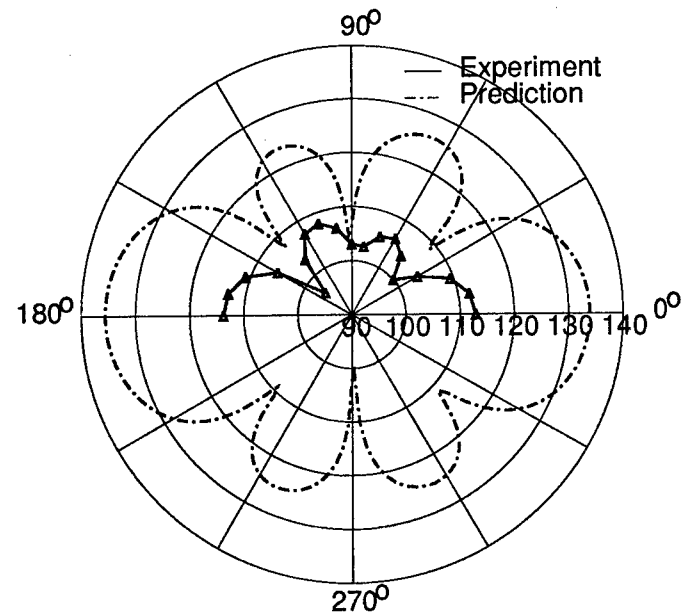

Figure B19: Test 6 - 3,5 Mode

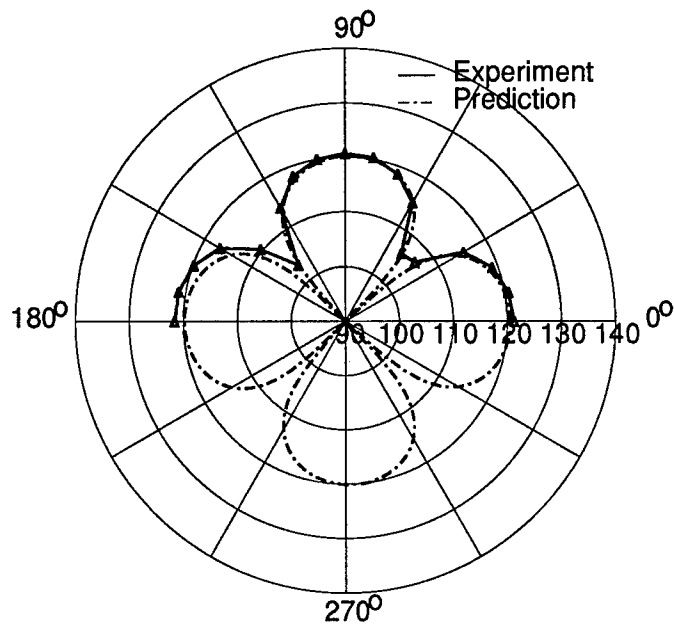

Figure B20: Test 6 - 2,5 Mode

B.1.5: Test 7

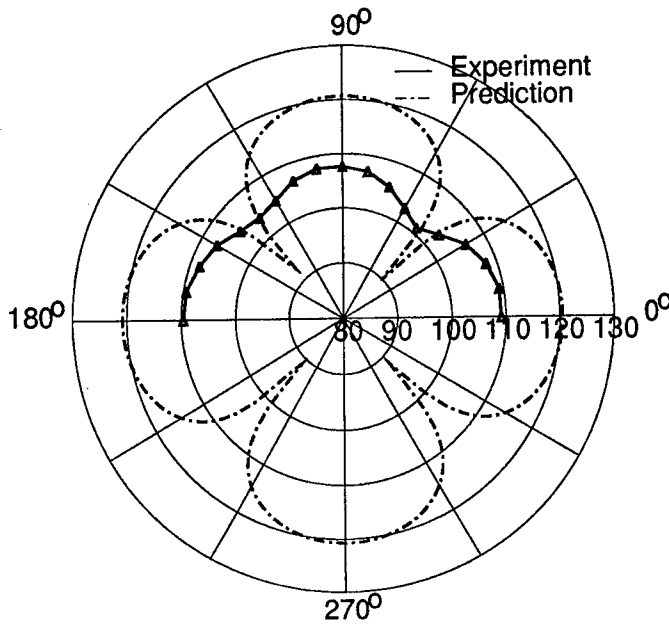

Figure B21: Test 7 - 2,1 Mode

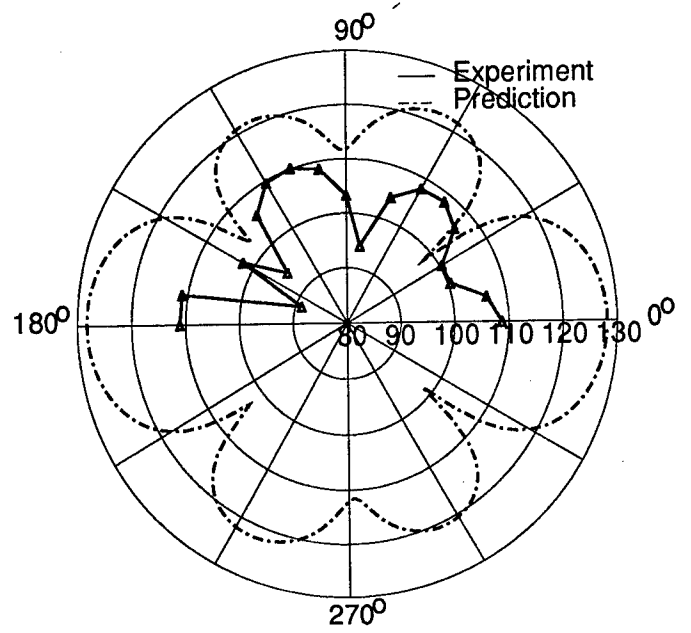

Figure B22: Test 7 - 3,1 Mode

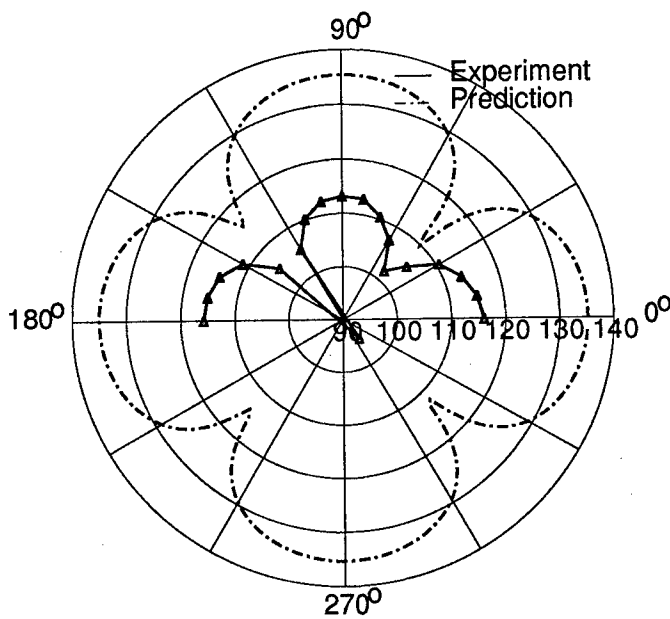

Figure B23: Test 7 - 2,3 Mode

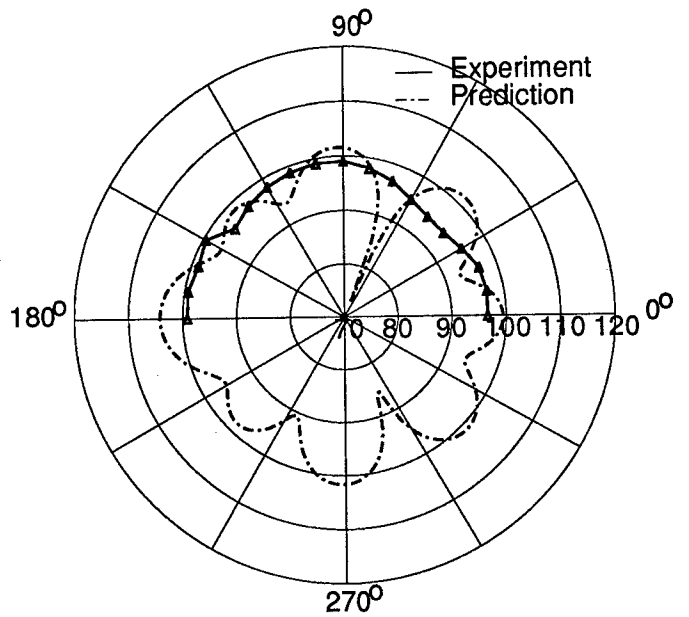

Figure B24: Test 7 - 4,1 Mode

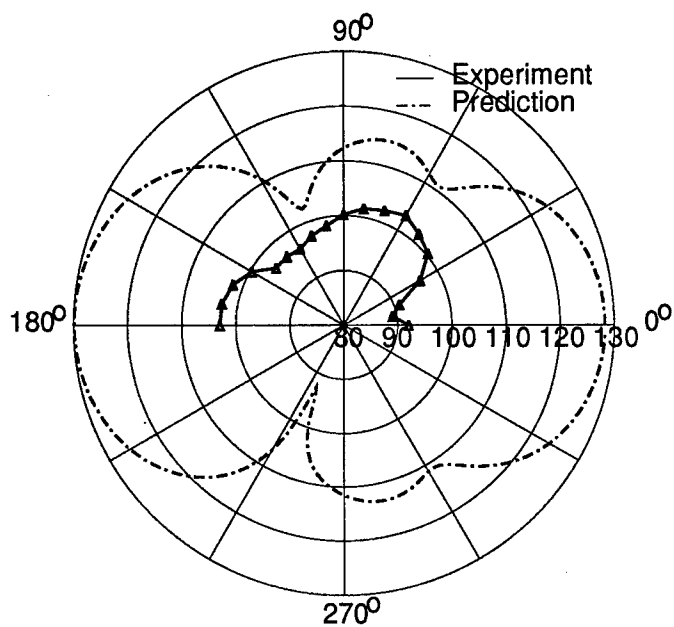

Figure B25: Test 7 - 3,5 Mode

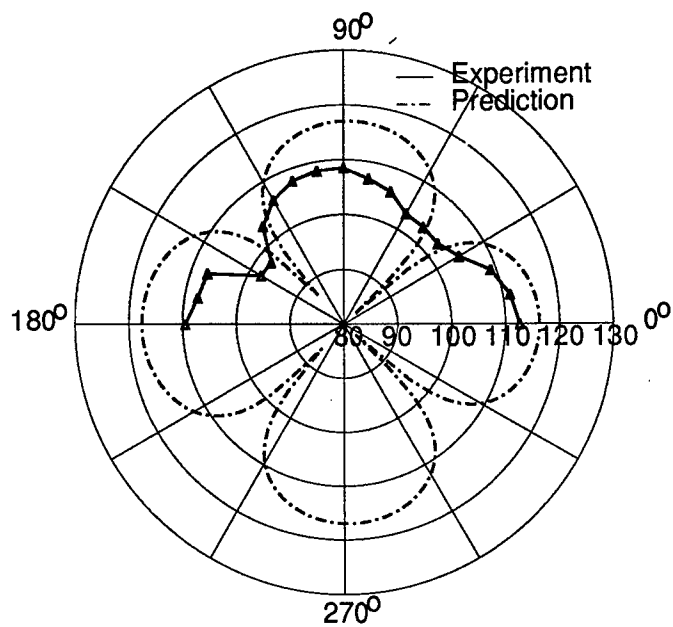

Figure B26: Test 7 - 2,5 Mode

B.1.6: Test 8

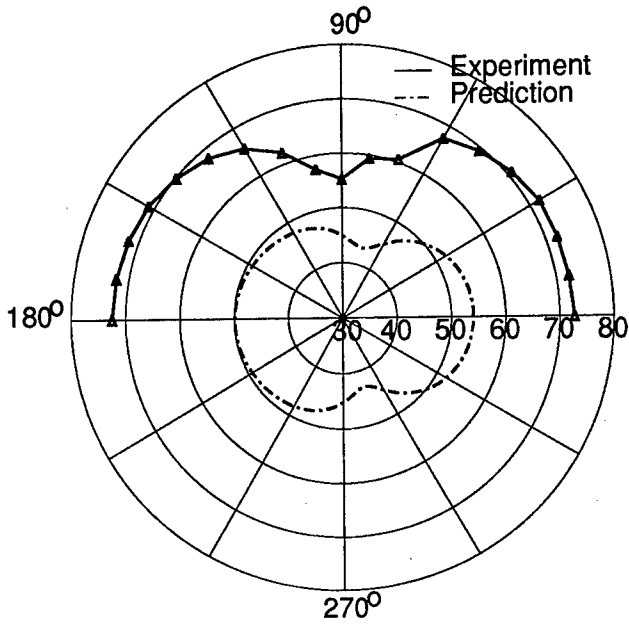

Figure B27: Test 8 - 50 Hz

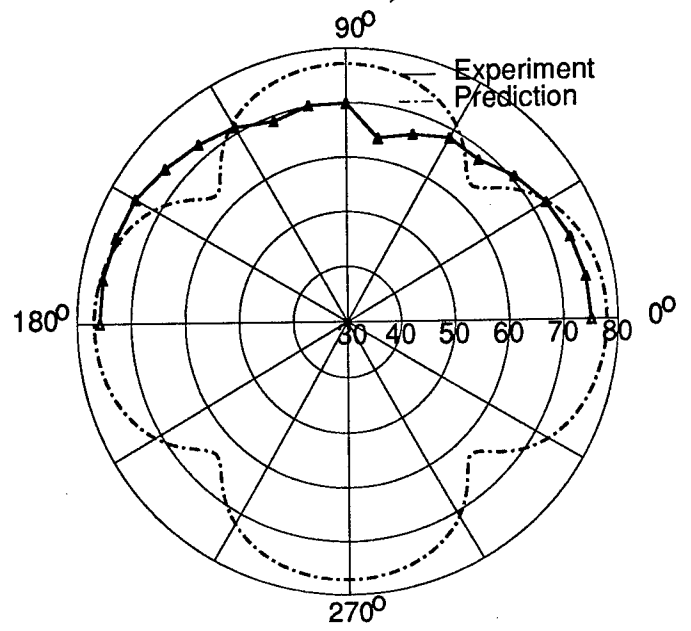

Figure B28: Test 8 - 100 Hz

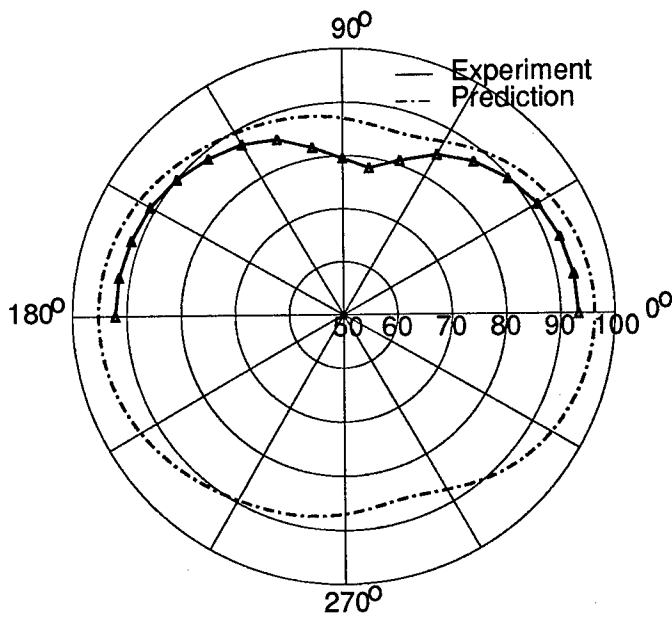

Figure B29: Test 8 - 250 Hz

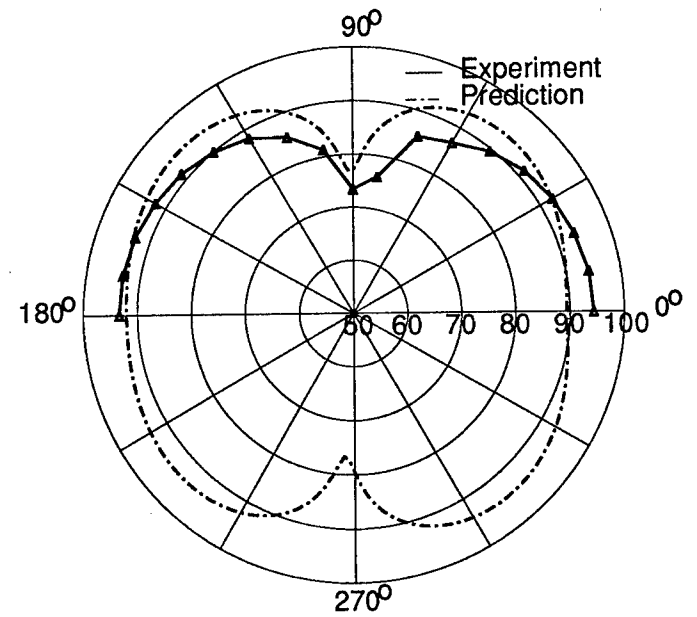

Figure B30: Test 8 - 400 Hz

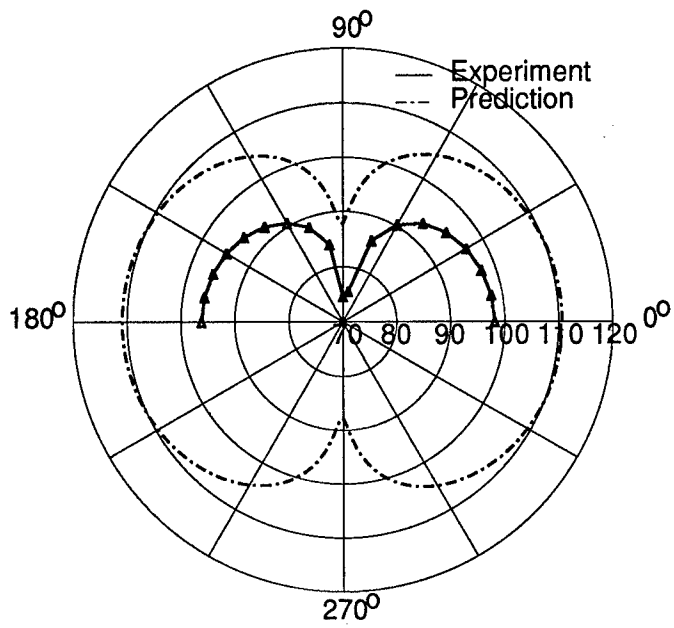

Figure B31: Test 8 - 500 Hz

B.1.7: Test 9

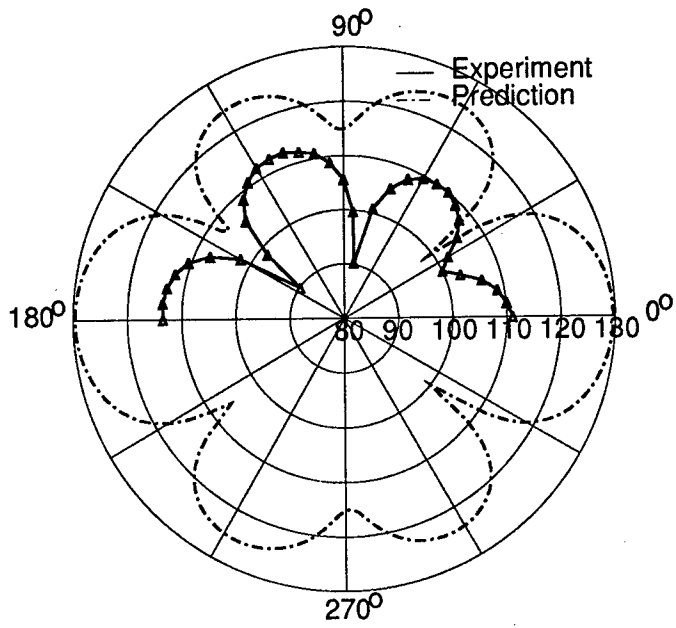

Figure B32: Test 9 - 3,1 Mode

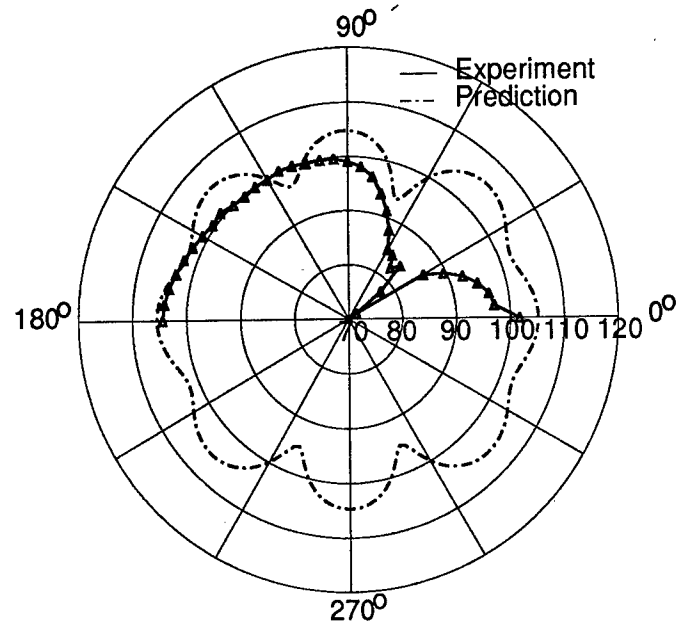

Figure B33: Test 9 - 4,1 Mode

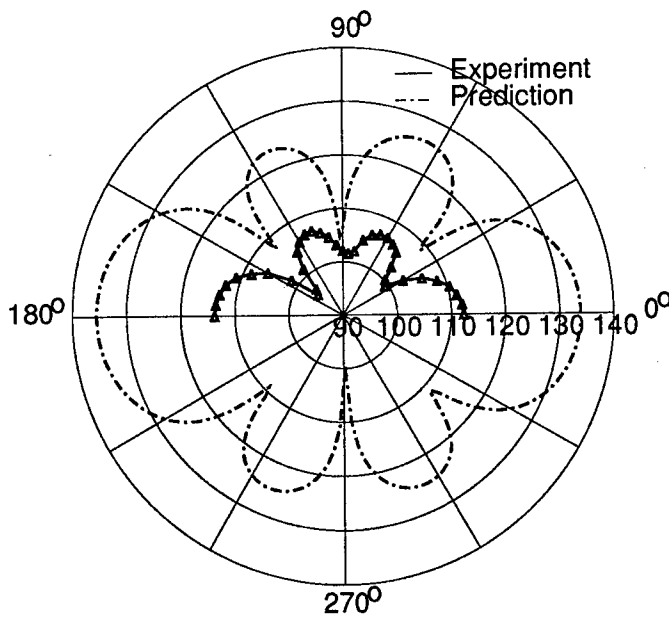

Figure B34: Test 9 - 3,5 Mode

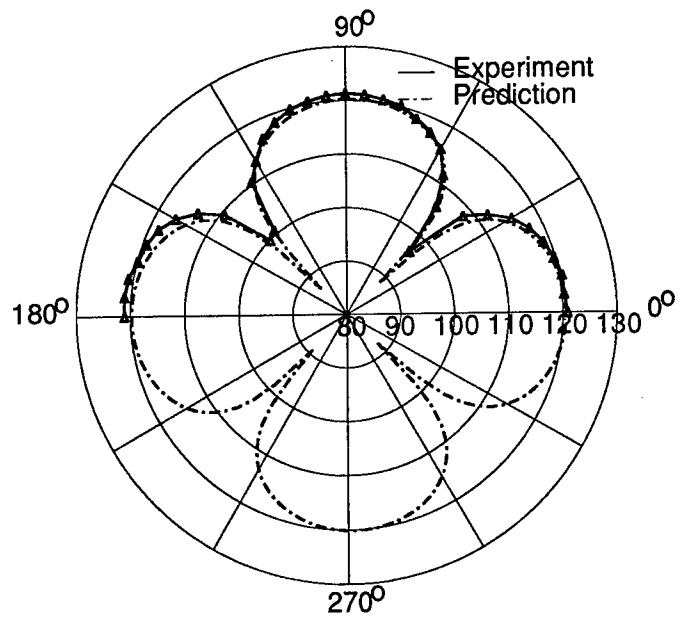

Figure B35: Test 9 - 2,5 Mode

B.2 Vertical Cylinder - Linear Plots

B.2.1 Test L1

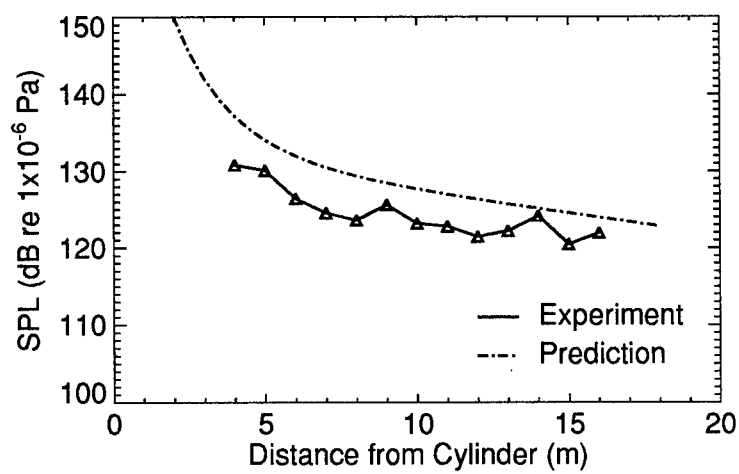

Figure B36: Test L1 - 2,1 Mode

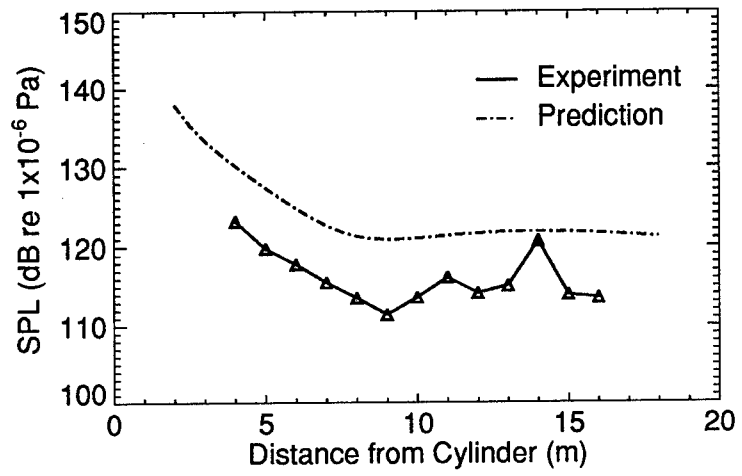

Figure B37: Test L1 - 1,1 Mode

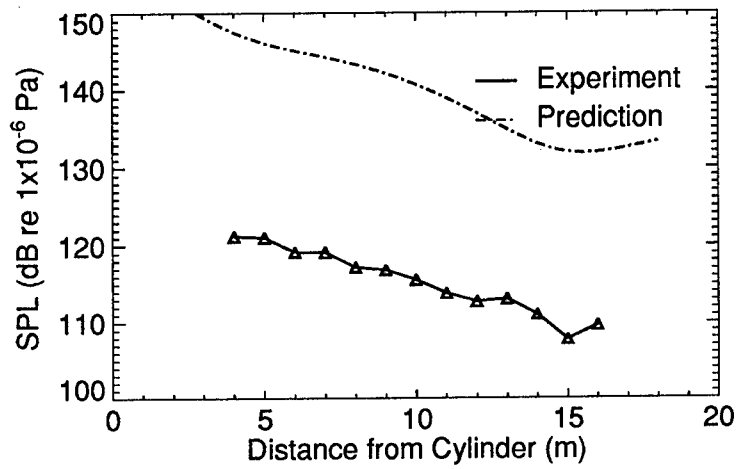

Figure B38: Test L1 - 3,1 Mode

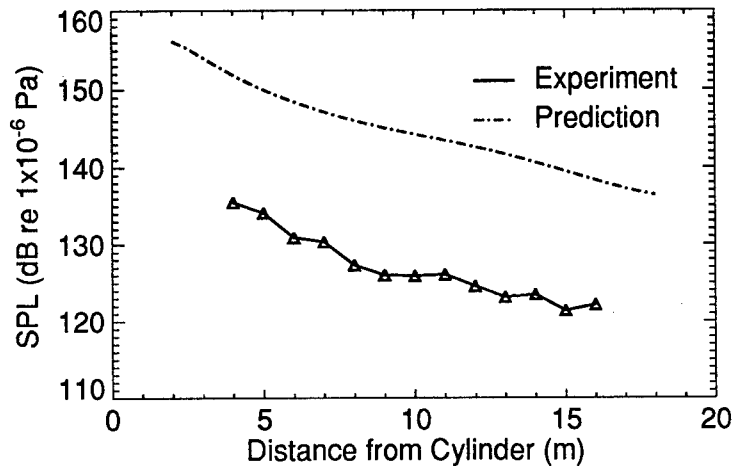

Figure B39: Test L1 - 2,3 Mode

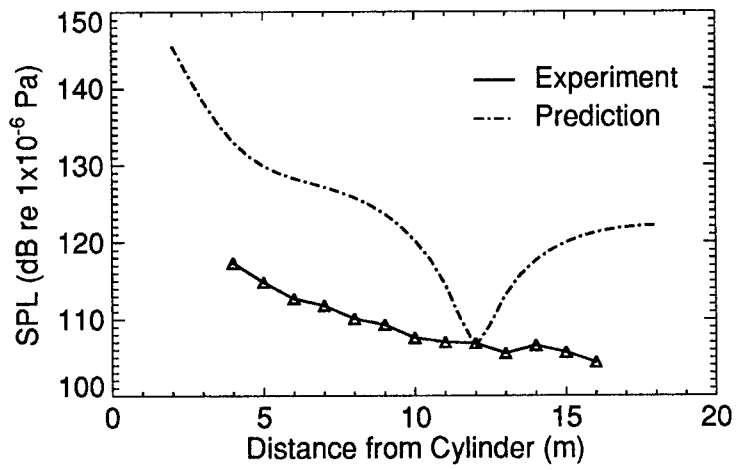

Figure B40: Test L1 - 3,3 Mode

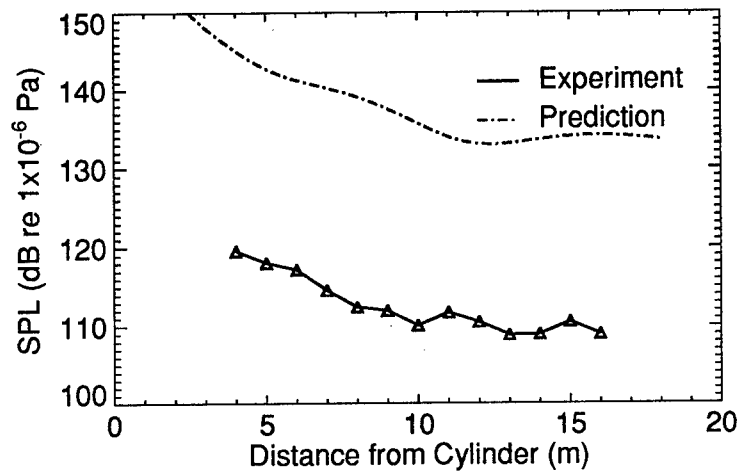

Figure B41: Test L1 - 4,1 Mode

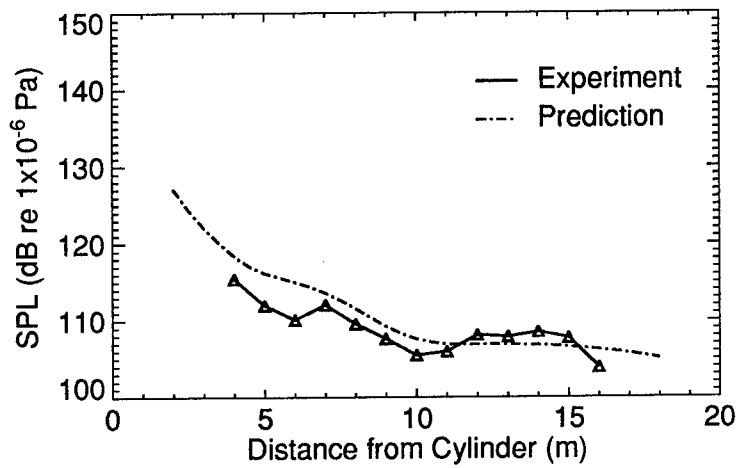

Figure B42: Test L1 - 4,1 Mode

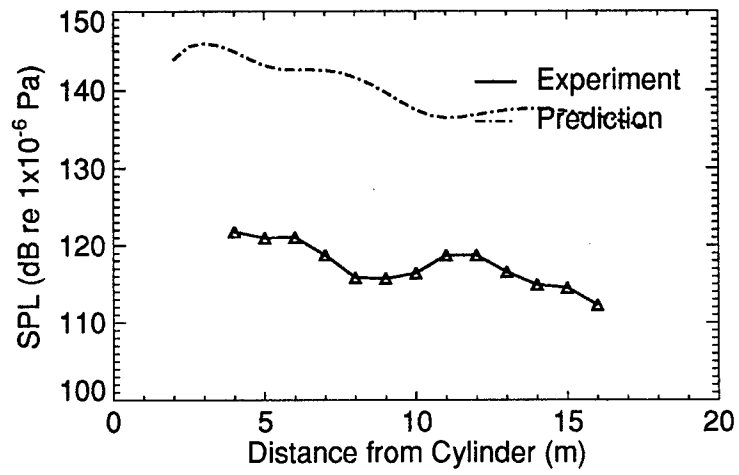

Figure B43: Test L1 - 3,5 Mode

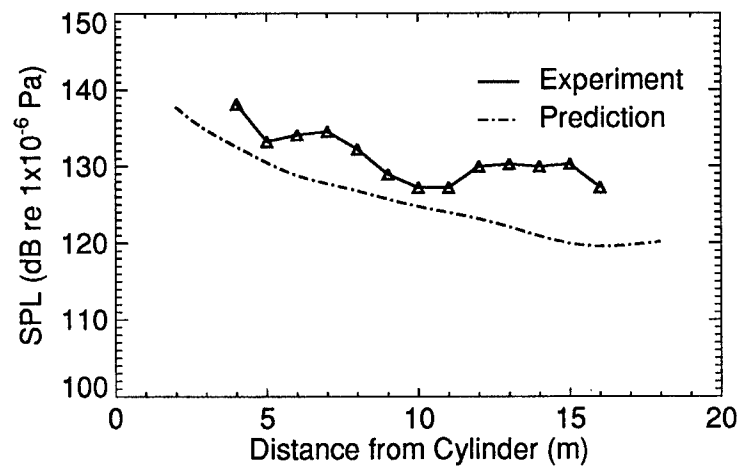

Figure B44: Test L1 - 2,5 Mode

B.2.2 Test L2

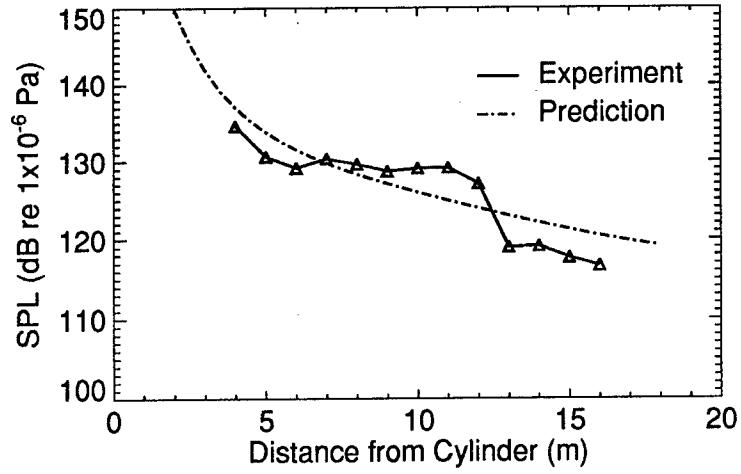

Figure B45: Test L2 - 2,1 Mode

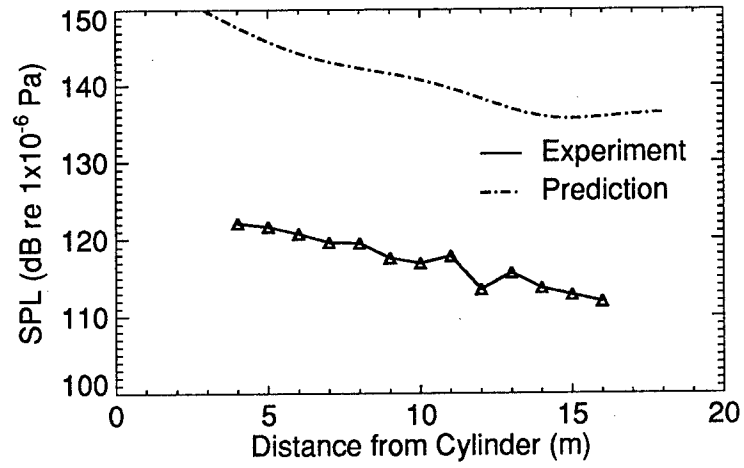

Figure B46: Test L2 - 3,1 Mode

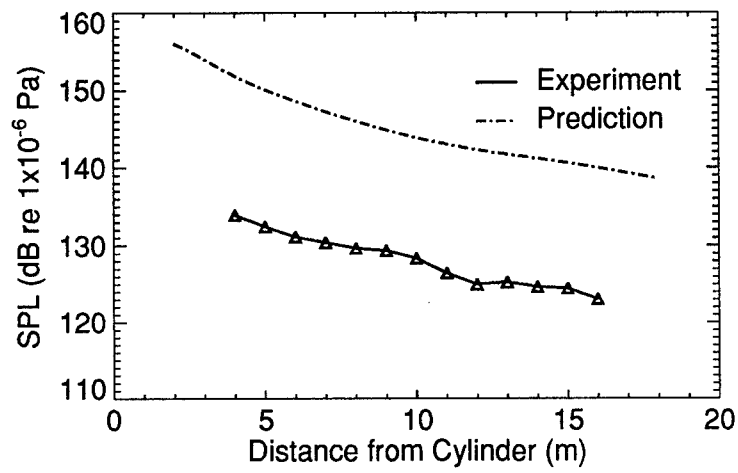

Figure B47: Test L2 - 2,3 Mode

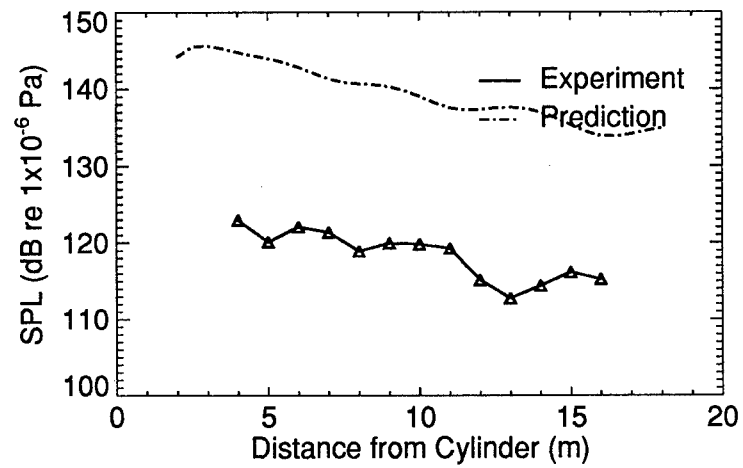

Figure B48: Test L2 - 3,5 Mode

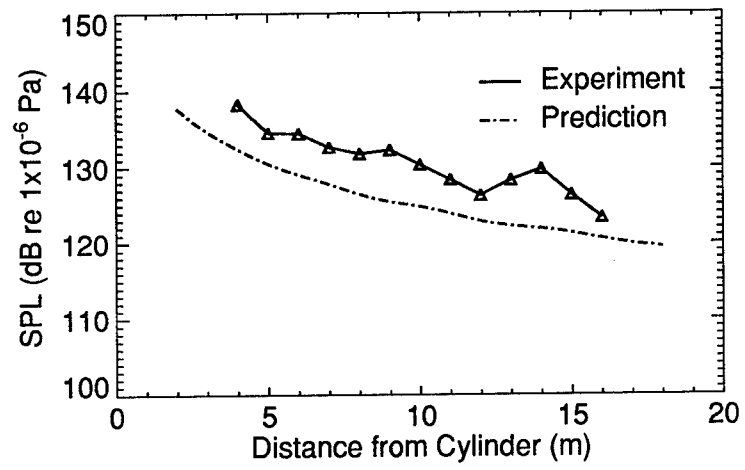
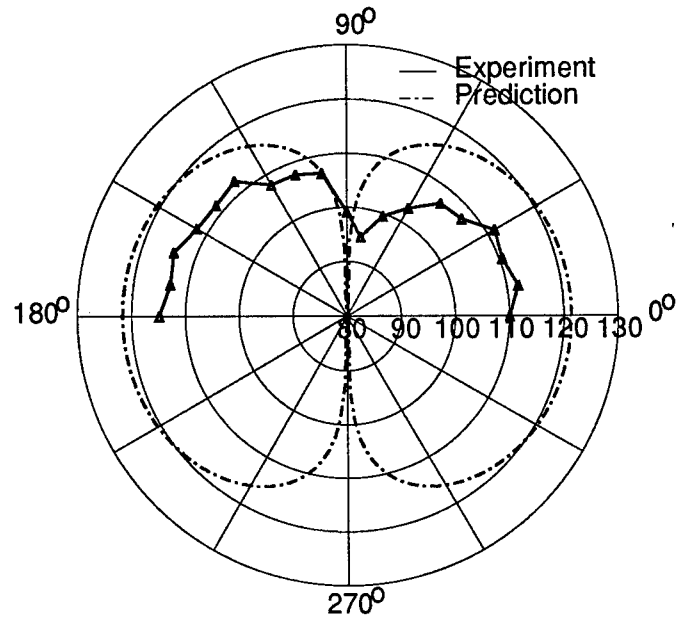
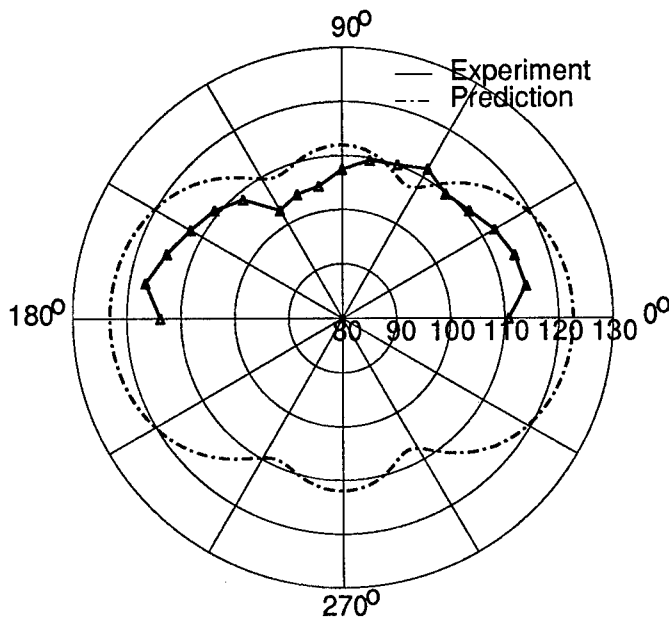

Figure B49: Test L2 - 2,5 Mode

B.3 Horizontal Cylinder

B.3.1 Test 1



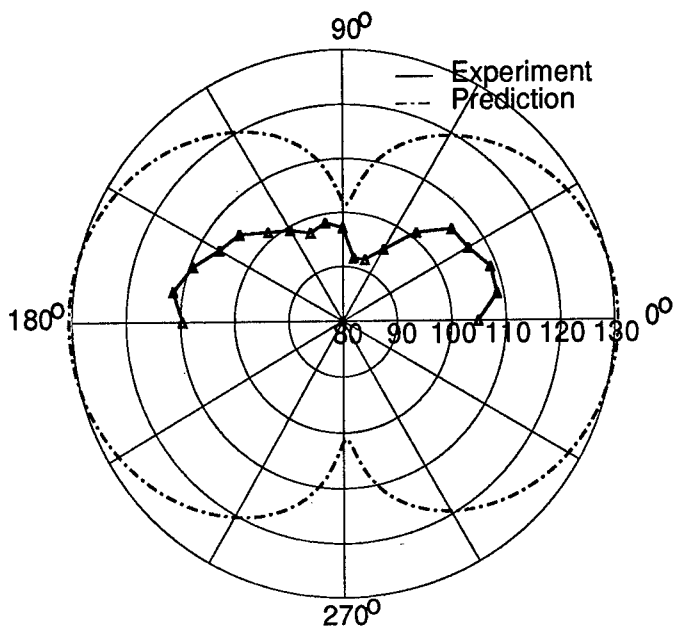

Figure B52: Test H1 - 3,1 Mode

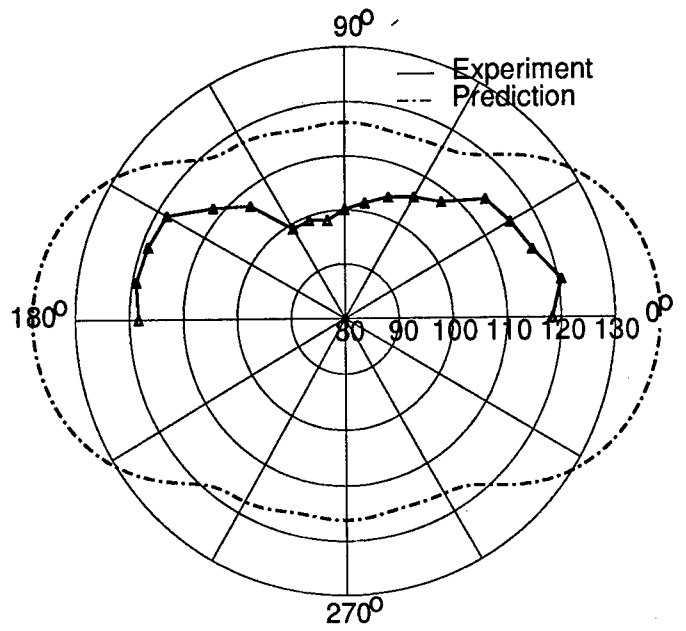

Figure B53: Test H1 - 2,3 Mode

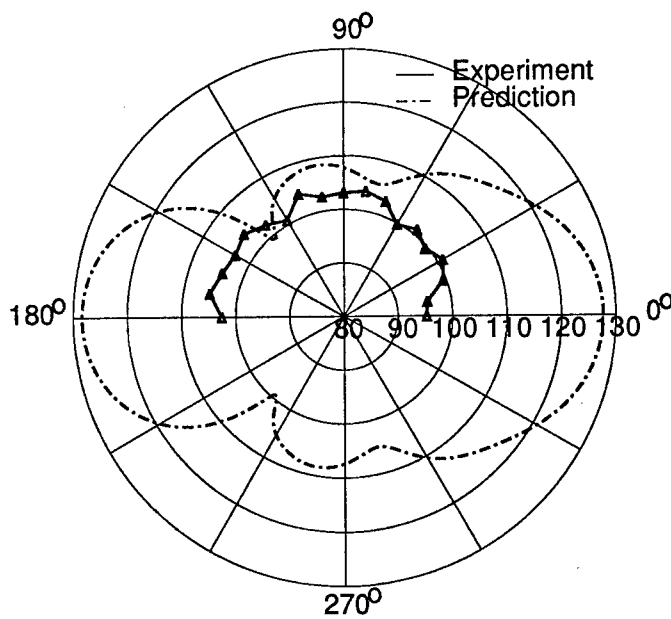

Figure B54: Test H1 - 3,3 Mode

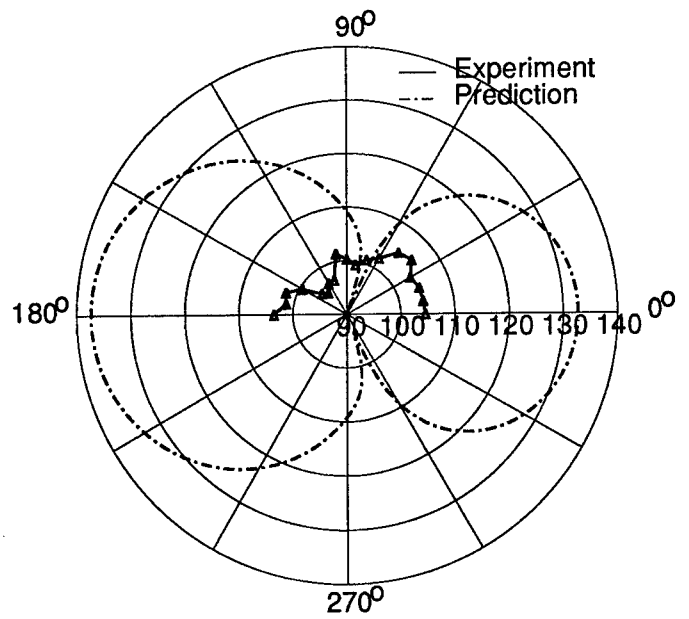

Figure B55: Test H1 - 4,1 Mode

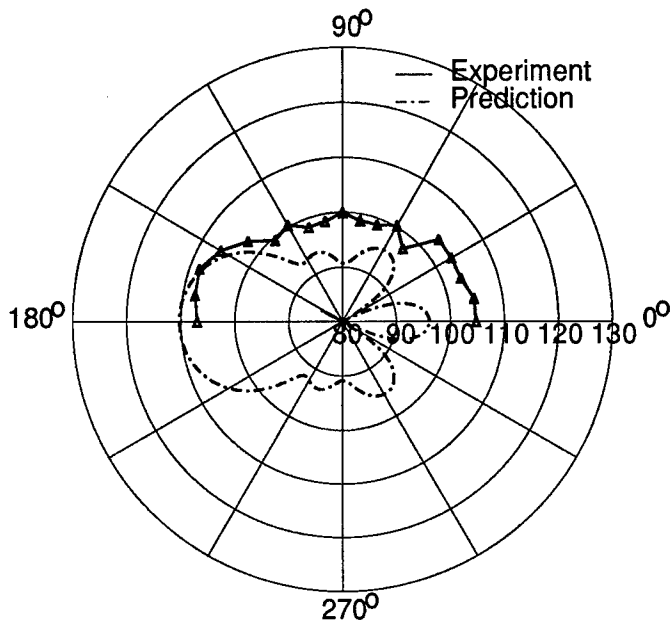

Figure B56: Test H1 - 4,1 Mode

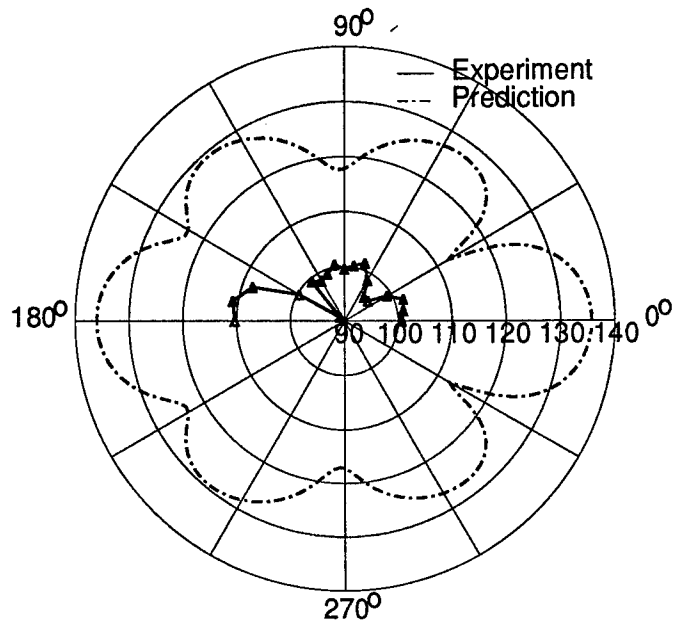

Figure B57: Test H1 - 3,5 Mode

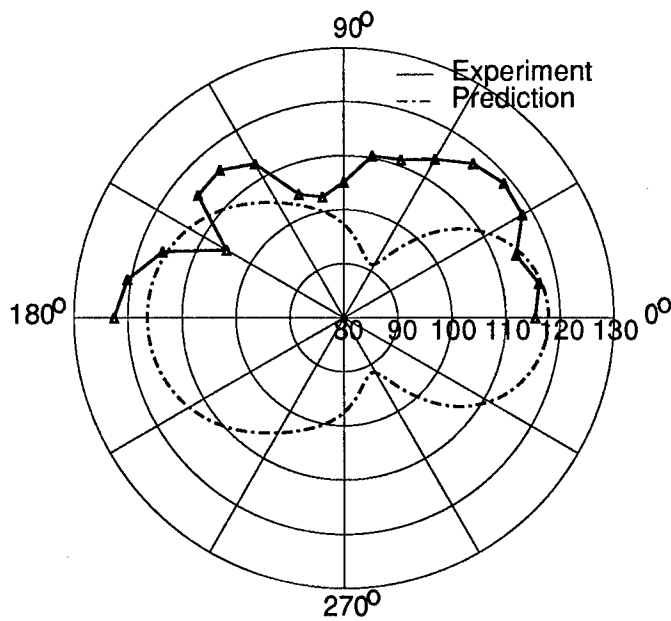

Figure B58: Test H1 - 2,5 Mode

References

- [1] Vernon, T.A., "Finite Element Formulations for Coupled Fluid/Structure Eigenvalue Analysis," DREA Technical Memorandum 89/223, 1989.
- [2] Vernon, T.A., Tang, S., "Prediction of Acoustic Cavity Modes by Finite Element Methods," DREA Technical Communication 89/302, 1989.
- [3] Gilroy, L.E., Tang, S., "An Improved Finite-Element Based Method for Coupled Fluid/Structure Eigenvalue Analysis," DREA Technical Memorandum 91/209, 1991.
- [4] Gilroy, L.E., "Finite Element Methods for Analyzing Coupled Fluid/Structure Systems," *Proceedings of International Conference on Noise Control Engineering (Noise '93)*, M.J. Crocker and N.I. Ivanov, Ed., St. Petersburg, Russia, 1993.
- [5] McMahan, G.W., "New Floating Laboratory Facilitates Underwater Acoustic Measurements," *Canadian Electronics Engineering*, February, 1961.
- [6] McMahan, G.W., Sheffer, C.V., Chang, D.R., "Microcomputer-Controlled Transducer Calibration Facilities at the Defence Research Establishment Atlantic," *International Conference on Underwater Acoustic Calibration & Measurements*, Bracknell, UK, December, 1984.
- [7] Gilroy, L.E., "Natural Frequency and Radiated Noise Measurements on a Ring-Stiffened Cylinder," DREA Technical Memorandum 93/215, October, 1993.
- [8] Gilroy, L.E., "Natural Frequency and Radiated Noise Measurements on a Ring-Stiffened Cylinder - Experimental Data Annex," DREA Technical Communication 93/313, December, 1993.
- [9] "Vibration and Strength Analysis Program (VAST) : User's Manual Version 6.0," Martec Ltd., Halifax, Nova Scotia, 1990.
- [10] Seybert, A.F., Wu, T.W., "BEMAP User's Manual - Version 2.4", Spectronics, Inc., Lexington, Kentucky, 1989.
- [11] "Cylinder," DREA Drawing No. M21-0011.

UNCLASSIFIED

SECURITY CLASSIFICATION OF FORM
(highest classification of Title, Abstract, Keywords)

DOCUMENT CONTROL DATA (Security classification of title, body of abstract and indexing annotation must be entered when the overall document is classified)		
<p>1. ORIGINATOR (The name and address of the organization preparing the document. Organizations for whom the document was prepared, e.g. Establishment sponsoring a contractor's report, or tasking agency, are entered in section 8.)</p> <p>Defence Research Establishment Atlantic P.O. Box 1012, Dartmouth, N.S. B2Y 3Z7</p>	<p>2. SECURITY CLASSIFICATION (Overall security of the document including special warning terms if applicable.)</p> <p align="center">UNCLASSIFIED</p>	
<p>3. TITLE (The complete document title as indicated on the title page. Its classification should be indicated by the appropriate abbreviation (S,C,R or U) in parentheses after the title.)</p> <p align="center">Predicting Radiated Sound from a Submerged Ring-Stiffened Cylinder</p>		
<p>4. AUTHORS (Last name, first name, middle initial. If military, show rank, e.g. Doe, Maj. John E.)</p> <p align="center">Gilroy, Layton E.</p>		
<p>5. DATE OF PUBLICATION (Month and year of publication of document.)</p> <p align="center">March 1997</p>	<p>6a. NO. OF PAGES (Total containing information. Include Annexes, Appendices, etc.)</p> <p align="center">71</p>	<p>6b. NO. OF REFS. (Total cited in document.)</p> <p align="center">11</p>
<p>6. DESCRIPTIVE NOTES (The category of the document, e.g. technical report, technical note or memorandum. If appropriate, enter the type of report, e.g. interim, progress, summary, annual or final. Give the inclusive dates when a specific reporting period is covered.)</p> <p align="center">Technical Memorandum</p>		
<p>8. SPONSORING ACTIVITY (The name of the department project office or laboratory sponsoring the research and development. include the address.)</p> <p>Defence Research Establishment Atlantic P.O. Box 1012, Dartmouth, N.S. B2Y 3Z7</p>		
<p>9a. PROJECT OR GRANT NUMBER (If appropriate, the applicable research and development project or grant number under which the document was written. Please specify whether project or grant.)</p> <p align="center">Project 1.g.a</p>	<p>9b. CONTRACT NUMBER (If appropriate, the applicable number under which the document was written.)</p>	
<p>10a. ORIGINATOR'S DOCUMENT NUMBER (The official document number by which the document is identified by the originating activity. This number must be unique to this document.)</p> <p align="center">DREA Technical Memorandum 96/237</p>	<p>10b. OTHER DOCUMENT NUMBERS (Any other numbers which may be assigned this document either by the originator or by the sponsor.)</p>	
<p>11. DOCUMENT AVAILABILITY (Any limitations on further dissemination of the document, other than those imposed by security classification)</p> <p><input checked="" type="checkbox"/> Unlimited distribution <input type="checkbox"/> Distribution limited to defence departments and defence contractors; further distribution only as approved <input type="checkbox"/> Distribution limited to defence departments and Canadian defence contractors; further distribution only as approved <input type="checkbox"/> Distribution limited to government departments and agencies; further distribution only as approved <input type="checkbox"/> Distribution limited to defence departments; further distribution only as approved <input type="checkbox"/> Other (please specify):</p>		
<p>12. DOCUMENT ANNOUNCEMENT (Any limitation to the bibliographic announcement of this document. This will normally correspond to the Document Availability (11). However, where further distribution (beyond the audience specified in 11) is possible, a wider announcement audience may be selected.)</p> <p align="center">Full, unlimited</p>		

UNCLASSIFIED

SECURITY CLASSIFICATION OF FORM

DCDO3 2/06/87

UNCLASSIFIED
SECURITY CLASSIFICATION OF FORM

13. **ABSTRACT** (a brief and factual summary of the document. It may also appear elsewhere in the body of the document itself. It is highly desirable that the abstract of classified documents be unclassified. Each paragraph of the abstract shall begin with an indication of the security classification of the information in the paragraph (unless the document itself is unclassified) represented as (S), (C), (R), or (U). It is not necessary to include here abstracts in both official languages unless the text is bilingual).

Defence Research Establishment Atlantic (DREA) conducted experiments involving the measurement of radiated noise from a submerged ring-stiffened cylinder subjected to a harmonic load. These experiments were performed to provide validation data for structural acoustics computer codes being developed in-house and under contract. These codes are used to predict the vibrations of structures submerged in, or filled with, a dense fluid and also to predict the resulting radiated noise. This suite of codes, comprising the programs VAST, COUPLE, and BEMAP, was used to predict the natural frequencies and radiated noise, on-and off-resonance, from this cylinder. Comparisons are made between the predicted and measured natural frequencies and radiated noise levels and directivity. Overall, the programs were able to accurately predict both the structural resonances and the radiated noise patterns.

14. **KEYWORDS, DESCRIPTORS or IDENTIFIERS** (technically meaningful terms or short phrases that characterize a document and could be helpful in cataloguing the document. They should be selected so that no security classification is required. Identifiers, such as equipment model designation, trade name, military project code name, geographic location may also be included. If possible keywords should be selected from a published thesaurus. e.g. Thesaurus of Engineering and Scientific Terms (TEST) and that thesaurus-identified. If it not possible to select indexing terms which are Unclassified, the classification of each should be indicated as with the title).

sound pressure level
underwater
noise
radiation
acoustic
natural frequency
finite element
boundary element
cylinder
structures
resonance
directivity

UNCLASSIFIED
SECURITY CLASSIFICATION OF FORM

**D
R
E
A**



**C
R
D
A**