

**STTR PHASE I - FINAL REPORT**  
**EPITAXIAL GROWTH OF SiC USING MBE**  
**CONTRACT NO. N00014-94-C-0222**

**CONTRACT PERIOD**

9/23/94 - 12/27/96

**SUBMITTED TO**

Office of Naval Research  
ATTN: Mr. Alvin M. Goodman, Program Officer  
Ballston Tower One  
800 North Quincy Street  
Arlington, VA 22217-5660

**SUBMITTED BY**

UES, INC.  
4401 Dayton-Xenia Road  
Dayton, OH 45432  
(937) 426-6900

19970505 129

**DTIC QUALITY INSPECTED 1**

# REPORT DOCUMENTATION PAGE

Form Approved  
OMB No. 0704-0188

Public reporting burden for this collection of information is estimated to average 1 hour per response, including the time for reviewing instructions, searching existing data sources, gathering and maintaining the data needed, and completing and reviewing the collection of information. Send comments regarding this burden estimate or any other aspect of this collection of information, including suggestions for reducing this burden, to Washington Headquarters Services, Directorate for Information Operations and Reports, 1215 Jefferson Davis Highway, Suite 1204, Arlington, VA 22202-4302, and to the Office of Management and Budget, Paperwork Reduction Project (0704-0188), Washington, DC 20503.

1. AGENCY USE ONLY (Leave blank)	2. REPORT DATE <b>April 1997</b>	3. REPORT TYPE AND DATES COVERED <b>Final Report, 23 Sep 94 - 27 Dec 97</b>	
4. TITLE AND SUBTITLE <b>Expitaxial Growth of SiC Using MBE</b>		5. FUNDING NUMBERS  <b>N00014-94-C-0222</b>	
6. AUTHOR(S)  <b>Amarendra K. Rai</b>			
7. PERFORMING ORGANIZATION NAME(S) AND ADDRESS(ES)  <b>UES, Inc. 4401 Dayton-Xenia Road Dayton, OH 45432-1894</b>		8. PERFORMING ORGANIZATION REPORT NUMBER	
9. SPONSORING / MONITORING AGENCY NAME(S) AND ADDRESS(ES) <b>Office of Naval Research ATTN: Mr. Alvin M. Goodman, Program Officer Ballston Tower One 800 North Quincy Street Arlington, VA 22217-5660</b>		10. SPONSORING / MONITORING AGENCY REPORT NUMBER	
11. SUPPLEMENTARY NOTES			
12a. DISTRIBUTION / AVAILABILITY STATEMENT  <b>Approved for public release; STTR report, distribution unlimited</b>		12b. DISTRIBUTION CODE	
13. ABSTRACT (Maximum 200 words)  <b>This report addresses the development of molecular beam epitaxy technique for the growth of SiC thin film. In the course of this work, a molecular beam epitaxy system, Riber 32 GSMBE, was installed at the University of Cincinnati. The details of the MBE system are described in this report. Two preliminary experiments were carried out to demonstrate the epitaxial growth of SiC thin film. In the first experiment a Si-on-insulator (SOI) wafer was used as the substrate. The top Si layer of SOI was carbonized by rapid thermal chemical vapor deposition. Further growth of SiC on the carbonized layer was done by pyrolysis of silacyclobutane (SCB) in the MBE chamber. The second experiment utilized a Si wafer as the substrate and both carbonization and essential SiC growth was done in the MBE chamber. In situ reflection high energy electron diffraction (RHEED) experiments were performed to determine the epitaxial nature and crystalline quality of the SiC films. The chemical composition and film thicknesses were also determined using secondary ion mass spectroscopy (SIMS). It is concluded that epitaxial SiC growth can be accomplished with MBE technique with minimal (&lt;1%) impurity concentration.</b>			
14. SUBJECT TERMS  <b>Silicon carbide, Molecular beam epitaxy, Gas precursor, RHEED, SIMS</b>		15. NUMBER OF PAGES <b>28</b>	16. PRICE CODE
17. SECURITY CLASSIFICATION OF REPORT <b>Unclassified</b>	18. SECURITY CLASSIFICATION OF THIS PAGE <b>Unclassified</b>	19. SECURITY CLASSIFICATION OF ABSTRACT <b>Unclassified</b>	20. LIMITATION OF ABSTRACT  <b>UL</b>

## **PREFACE**

This technical report has been prepared as part of the requirement of the Phase I STTR Contract No. N00014-94-C-0222 with the Office of Naval Research. The report covers work conducted during the period 23 September 1994 through 27 December 1996 and constitutes the final report under this contract. The ONR Program Officer was Mr. Alvin M. Goodman.

## ACKNOWLEDGMENT

The author acknowledges the technical support provided by Professor Andrew J. Steckl, Dr. John Chen, and Mr. Ronald Birkhahn, of the Nanoelectronics Laboratory, University of Cincinnati. The work reported here has been supported by the following Small Business Technology Transfer (STTR) Program: Department of Defense - Contract No. N00014-94-C-0222, Program Officer - Mr. Alvin M. Goodman.

## TABLE OF CONTENTS

<u>SECTION</u>	<u>PAGE</u>
PREFACE .....	ii
ACKNOWLEDGMENT .....	iii
LIST OF ILLUSTRATIONS .....	v
LIST OF TABLES .....	vi
1.0 INTRODUCTION .....	1
2.0 SYSTEM DESCRIPTION .....	2
2.1 Load Lock .....	2
2.2 Rough Pumping .....	3
2.3 Growth Chamber .....	3
2.4 Sources .....	6
2.5 Electronics .....	7
2.6 Analysis Equipment .....	7
3.0 EPITAXY OF SiC - LITERATURE SURVEY .....	8
3.1 Heteroepitaxy .....	8
4.0 PRELIMINARY RESULTS .....	10
4.1 Experimental Conditions .....	10
4.2 Results and Discussion .....	12
5.0 SUMMARY AND FUTURE WORK .....	20
6.0 REFERENCES .....	21

## LIST OF ILLUSTRATIONS

<u>FIGURE</u>		<u>PAGE</u>
1	Schematic of University of Cincinnati MBE system from Riber .....	2
2	Photo of load lock with control electronics in background .....	3
3	Rough pump cart with mechanical and sorption pumps .....	4
4	Main growth chamber (on right) with all attachments .....	4
5	Riber MBE-32 manipulator .....	4
6	Schematic of growth chamber cell panel .....	5
7	Cut away view of standard effusion cell on MBE systems .....	6
8	Temperature program of SiC growth process by MBE .....	11
9	Typical RHEED pattern of 3C-SiC film by carbonization of SOI with RTCVD .....	13
10	Interpretation of the RHEED pattern in Fig. 9 .....	13
11	RHEED pattern of SiC film grown by MBE with SCB .....	14
12	RHEED patterns observed during SiC growth .....	15
13	SIMS depth profile of SiC film (sample C1) grown by two hours carbonization with C <sub>3</sub> H <sub>8</sub> . .....	16
14	SIMS depth profile of SiC film (sample CE1) grown by 20 min carbonization and 9 min essential growth by SCB. The SiC film thickness is 95Å .....	18
15	SIMS depth profile of SiC film (sample CE2) grown by 2 hours carbonization and 1 hour and 40 min essential grown by SCB. The film thickness is 600Å .....	19

**LIST OF TABLES**

<u>TABLE</u>		<u>PAGE</u>
1	Experiment conditions on SiC growth .....	11

## 1. INTRODUCTION

Silicon carbide (SiC) is a wide band gap semiconductor with high thermal stability and conductivity, high breakdown voltage, etc. Among many SiC polytypes, 3C-SiC (or  $\beta$ -SiC, the only cubic structure) is the most promising candidate for higher power, higher temperature and higher frequency electronic devices because of its high electron mobility ( $1000 \text{ cm}^2/\text{V s}$ ) [1], high saturated drift velocity (above  $10^7 \text{ cm/s}$ ) [2]. Since bulk crystals of 3C-SiC are very expensive and their size is very small ( $\sim 3 - 5 \text{ mm}$ ), heteroepitaxial growth on Si substrate has become an alternative method for growing SiC. Due to the large lattice constant mismatch (20%) and the thermal expansion coefficient difference (8%) between 3C-SiC and Si, considerable effort was devoted to improving the film quality, leading to a two-step epitaxial growth. The first step is carbonization of Si substrate to relieve the strain between SiC and Si, but this SiC layer is usually too thin (a few hundred Å) to fabricate devices. The second step is essential growth of SiC on SiC by introducing both Si and C precursors. Currently, CVD is widely employed to grow epitaxial 3C-SiC on Si. Since the epitaxial growth temperature in CVD is generally higher than  $1200^\circ\text{C}$ , which can cause deterioration of the film quality and redistribution of the dopants, reduction of growth temperatures must be realized in order to fabricate the SiC device. Molecular Beam Epitaxy (MBE) is a promising methods to reduce 3C-SiC growth temperatures.

The work described in this report was sponsored by an ONR STTR program. The following sections of this report consist of: a description of the Riber 32 MBE system recently installed at the University of Cincinnati; a brief summary of previous work on growing SiC with MBE; preliminary results on MBE growth of 3C-SiC on Si.

## 2. SYSTEM DESCRIPTION

The MBE system consists of these primary components: a control computer (1), control electronics and power supplies(2), gas cabinet (3), growth chamber (4), a load lock chamber (5), pumping systems. A schematic of the system is shown in Fig. 1.

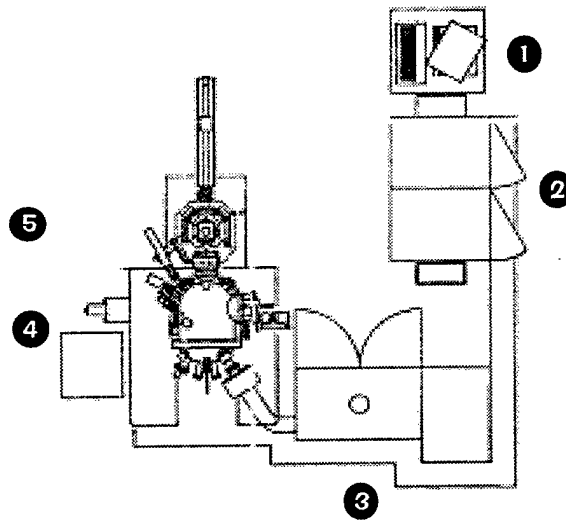

Fig. 1. Schematic of University of Cincinnati MBE system from Riber.

### 2.1 LOAD LOCK

The load lock (5) serves as a buffer chamber between atmosphere and the growth chamber which maintains UHV conditions. It contains a magnetically coupled sample transfer rod and a four-sample storage stage with one outgassing station that can reach temperature up to 800°C. The stage can move in XYZ directions and rotate 360°C. The load lock is pumped by an ion pump (200 l/s) supplemented with a titanium sublimation pump (1000 l/s). The base pressure of the chamber can reach  $1 \times 10^{-10}$  Torr after a 48 hour bakeout at 200°C. One UHV port for venting the chamber with UHP nitrogen and for rough pumping is located just below the ion pressure gauge. There is a gate valve to isolate the load lock chamber from the ion pump during venting and roughing, and another gate valve to isolate the load lock from the growth chamber. On one side of the load lock chamber is a back door for loading and unloading samples. The load lock has additional ports for future expansion with a surface analysis chamber. A photo of the UC MBE-32 load lock is shown in Fig. 2.



Fig. 2. Photo of load lock with control electronics in background.

## 2.2 ROUGH PUMPING

The rough pumping of the load lock and the growth chamber is done with a “rough pump cart” which consists of two LN<sub>2</sub>-cooled sorption pumps in parallel with a small mechanical pump (Fig. 3). The sorption pumps are first cooled to 77K and the mechanical pump is allowed to rough out the load lock to 150 Torr. Next, the two sorption pumps are opened and closed in series until the pressure reaches  $5 \times 10^{-2}$  Torr and  $1 \times 10^{-3}$  Torr, respectively. At that point, the chamber is isolated and the gate valve to the main pumping system is open.

## 2.3 GROWTH CHAMBER

The growth chamber (4) (shown in Fig. 4) contains a sample manipulator, a cell panel where the molecular sources are located, analysis tools (RHEED, RGA), LN<sub>2</sub> cryoshrouds, and UHV pumping. The transfer rod places the sample directly onto a xyz-controllable and rotatable manipulator (Fig. 5) that has heating capability to 1200°C via a specially designed heater from Karl Eberl (Stuttgart, Germany). UHV pumping consists of a CTI CT8 cryopump and a titanium sublimator. Pressures can go as low as  $5 \times 10^{-11}$  Torr after a 48 hour bakeout and  $1.2 \times 10^{-11}$  Torr

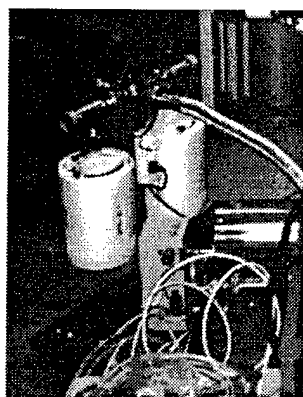

Fig. 3. Rough pump cart with mechanical and sorption pumps.

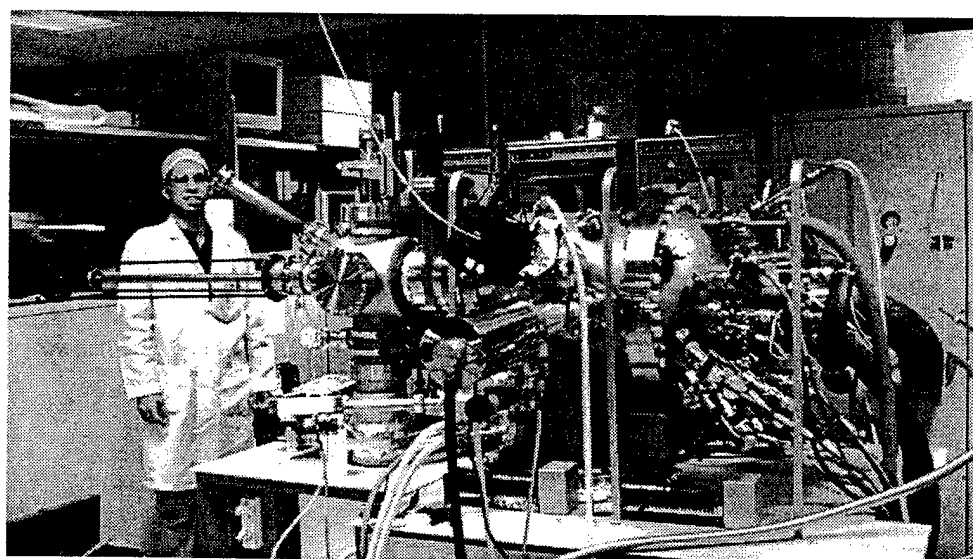

Fig. 4. Main growth chamber (on right) with all attachments. RGA (upper black box) and RHEED gun (just below) are shown in foreground.

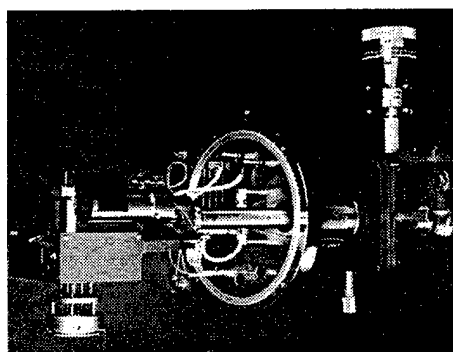
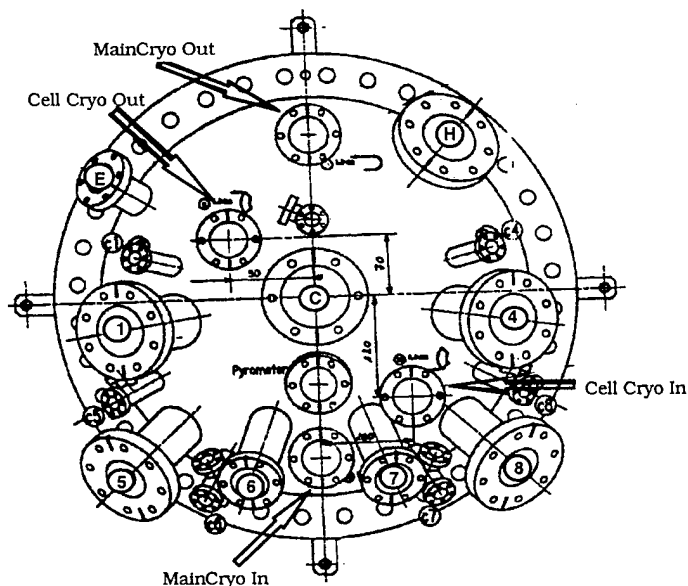

Fig. 5. Riber MBE-32 manipulator.

with the cryopanel cooled. The cryopanel consists of three LN<sub>2</sub>-filled shrouds for cooling the main chamber, the well surrounding the pumping systems, the cell panel to protect the sources from stray contaminants. Two ion gauges monitor the pressure in the system, one close to the pumping well and the second at the rear of the substrate holder to calibrate the fluxes from the cells incident on the sample. The cell panel (Fig. 6) contains both Knudsen effusion cells and a high temperature gas injector. In the future, it will be fitted with a plasma source to further enhance the capabilities of the system. Also on the cell panel is a viewport for a pyrometer (to be retrofitted), an XTC crystal thickness monitor, and shutter motors. The XTC is employed to measure film deposition rate from an electron beam gun used to melt source material. Analysis in the chamber is provided by an Inficon residual gas analyzer (RGA) and a Staib Instruments



PORTS	Flange/Clearance	Angle	Source
[1]	4.5"/2.75"CFF—1.75"	5°	Er-EPI High Temp
[C]	4.5"CFF—2.5"	0°	N2 Plasma
[4]	4.5"/2.75"CFF—1.75"	5°	Gas Injector
[5]	4.5"/2.75"CFF—1.75"	32°	Mg-Riber (?)
[6]	2.75"CFF—1.75"	32°	Ga-EPI SUMO
[7]	2.75"CFF—1.75"	32°	In-EPI SUMO
[8]	4.5"/2.75"CFF—1.75"	32°	Al-Riber (?)
[E]			Ellipsometer
[H]			Sensor for electron gun

Fig. 6. Schematic of growth chamber cell panel.

35 kV reflection high energy electron diffraction (RHEED) gun. The RGA is used to determine the background contaminants in the chamber and the process species during growth. The RHEED gun is used to determine the crystallinity and growth rates on the substrate. This will be discussed in a later section.

## 2.4 SOURCES

Figure 6 shows the setup of the cell panel and location of the sources on the MBE system. Ports 1,5-8 are fitted with Knudsen cells (shown schematically in Fig. 7) and to be filled with solid source ultra high purity (UHP) material for evaporation. An EPI high temperature cell resides in port 1 capable of temperatures near 2000°C and is scheduled to be filled with Er. Since port 1 is in a low angle position (5°), the crucible can only hold a small charge in comparison to the bottom row (5-8) at 32°. Ports 5 and 8 contain Riber single filament cells filled with Mg and Al, both dopants in the nitrides and SiC. Cells 6 and 7 are EPI Sumo dual filament cells designed to reduce cell “spitting” during operation and increase uniformity. These will be filled with Ga and In for growth of nitrides and other semiconductor heterostructures. A three-line gas injector and cracker is installed in cell 4. The injector has 1200°C temperature capability, two baratron flow controllers, and one mass flow controller. Each line has a manifold to switch between 2 different gasses: line one has silacyclobutane (SCB  $\text{SiC}_3\text{H}_8$ ) and

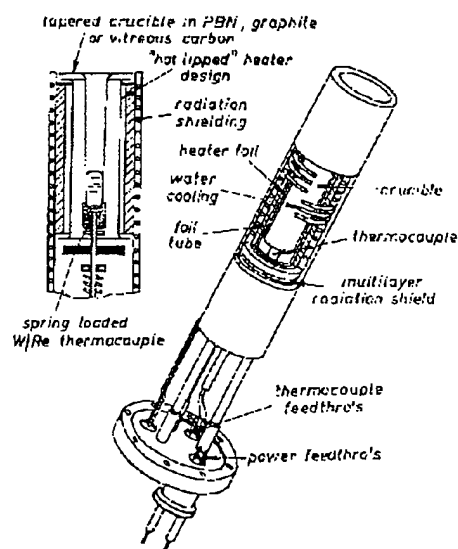

Fig. 7. Cut away view of standard effusion cell on MBE systems.

propane ( $C_3H_8$ ), line two has dilution  $N_2$  or ammonia ( $NH_3$ ), and line three has  $H_2$ . The center port on the chamber is reserved for a nitrogen plasma source for growing nitrides.

## 2.5 ELECTRONICS

A gas cabinet (3) to the left of the cell panel houses the cylinders for the three-line gas injector and a mechanical pump that evacuates the gas lines and the cryopump exhaust. The gas cabinet electronics, power supplies, pressure gauges, safety actuators, and temperature controllers are all located in racks (2) next to the system. Two control computers (1) are used to integrate the electronics: one PC operating in the NextStep Unix environment using a Riber program called Accessible to integrate all the growth components of the system; a second PC running under DOS/Windows to operate the RGA and RHEED gun.

## 2.6 ANALYSIS EQUIPMENT

In situ analysis is one crucial advantage that MBE has over other growth processes. This is made possible by the UHV conditions inside the growth chamber. The environment in the chamber can be monitored by the RGA before, during, and after the run. This can determine the quantities of reactive species in the chamber, help locate the origin of grown-in impurities, and evaluate the condition of the pumping. We have installed a Leybold Inficon H100M quadrupole with a Faraday cup for high pressure gas analysis and an electron multiplier for low ( $<10^{-6}$  Torr) pressures. For surface-sensitive analysis of the substrate, we have a Staib Instruments 35kV electron gun for obtaining RHEED patterns. This can quantify the substrate condition, from the effectiveness of the pre-cleaning and outgassing to the atomic growth characteristics and subsequent annealing effectiveness. RHEED can also be used to determine growth rates and surface reconstructions.

### 3. Epitaxy of SiC - Literature Survey

#### 3.1 Heteroepitaxy

Carbonization is an effective process to relax the large lattice mismatch between Si and SiC. There are two different carbonization processes. In the first process, the Si substrate is annealed to high temperature (750 - 1100°C) and then hydrocarbon gas or carbon (atoms or ions) are introduced to react with Si surface. Several simple hydrocarbon molecules, such as C<sub>2</sub>H<sub>2</sub>, C<sub>2</sub>H<sub>4</sub>, C<sub>3</sub>H<sub>8</sub> have been commonly used as carbon source. The gas pressure during carbonization varied from 10<sup>-9</sup> to 10<sup>-5</sup> Torr. Some researchers found the carbonized films were polycrystalline by this process [3 - 5], while others obtained films of good quality [6 - 9].

In the second process, carbon containing gas is first introduced into the chamber until the desired pressure is reached, and then the substrate temperature is raised to high temperatures (750 - 1100°C) at a slow ramp rate (5 - 25°C/min). There are several versions of this process, with variations in the temperature ramp rate at different temperature stages and the incorporation of an oxide removal step [3]. In general, this process is very effective for obtaining single crystal 3C-SiC without double- positioning twin structures and pits [3-5]. This process probably seals off the outward Si diffusion from the Si substrate, which is believed to cause surface defects [4,5].

Essential growth of SiC is used to further grow SiC on the carbonized film with both Si- and C- containing source. The substrate temperature ranges from 750 to 1100°C, the total pressure is usually 10<sup>-7</sup> to 10<sup>-5</sup> torr during growth. The effect of the flux ratio between Si and C species on film quality and stoichiometric ratio has been extensively studied [5,10-13]. It was found that  $J_{Si}/J_C > 1$  is a general rule for growing good crystalline 3C-SiC film with 1:1 stoichiometric ratio. Atomic layer epitaxy by MBE has also attracted a lot of attention [14-17]. It was found that the surface superstructures during an alternating supply of C source and Si source can be used to control film growth to atomic level accuracy.

### **Lattice matched growth**

The lattice constant of (111) 3C-SiC nearly matches ( $< 0.1\%$ ) that of the C-face of 6H-SiC. 6H-SiC is commercially available from several sources, with Cree Research being the main supplier. 6H-SiC is also used as a substrate for growing good quality SiC films. Some results show that the epitaxially grown 3C-SiC(111) on 6H-SiC(1000) at 850 -1000°C have double-positioning twin structure [18- 19], while on 6H-Si(0114) substrate, the 3C-SiC(100) epilayers were grown without twin structures of temperature as low as 850°C [19].

Homoepitaxy of 6H-SiC was also investigated and growth process controlled to an atomic level was obtained by monitoring surface superstructures during the supply of Si and C atoms [20-22]. The grown film is predominantly 6H-SiC with small amount of 3C-SiC mainly located at defect sites. These defects mostly extend from the substrate into the film.

## 4. PRELIMINARY RESULTS

### 4.1 EXPERIMENTAL CONDITIONS

The epitaxial growth of 3C-SiC was carried in a Riber GSMBE 32 system. The detailed description of the system was described above. Briefly, the epitaxial growth process starts with the growth chamber being evacuated by the Ti sublimation pump and cryogenic pump. After 60 hours baking at 250°C, a base pressure of  $3 \times 10^{-11}$  torr can be routinely obtained without filling the cryoshroud with liquid nitrogen. A quadrupole mass analyzer and a 35 keV reflection high-energy electron diffraction (RHEED) are mounted on the growth chamber for gas analysis and surface crystallinity characterization, respectively. A high temperature gas injector (1200°C) with three gas lines is employed to introduce propane and silocyclobutane ( $\text{SiC}_3\text{H}_8$  - SCB) into the growth chamber. The gas flow is controlled by a PID controller. The substrate is introduced through the load lock chamber which was pumped by a Ti sublimation pump and an ion pump to  $< 5 \times 10^{-10}$  Torr. The initial outgassing of the sample is also performed in this chamber. The sample was transported by a magnetically coupled transfer rod into the growth chamber and locked onto a five-dimensional manipulator which contains a high temperature (1200°C), high uniformity oven. The heater temperature is measured by a W-Re thermocouple and controlled by a PID controller.

Two preliminary experiments have been carried out. In the first experiment a SOI (Si On Insulator) wafer with (111) orientation was used as the substrate for a carbonized SiC MBE growth. The carbonization was done by rapid thermal CVD. The carbonized SOI sample was cleaned by dipping into 1% HF for 1 min and rinsing in DI water for 2 min. The sample was then introduced into the load lock chamber, where it was outgassed at 300°C for 12 hours. After the sample was transferred into growth chamber it was heated to 1000°C until a sharp RHEED pattern with 6-fold rotation symmetry indicating a clean  $\beta$ -SiC surface was observed. The further growth on the carbonized film was done by SCB pyrolysis with a sample temperature of 1000°C.

The second experiment utilized a Si(100) wafer as substrate. Both carbonization and essential growth were carried out in the MBE system. Propane was used for carbonization and SCB for essential growth on the carbonized film. The temperature program is shown in Fig. 8.

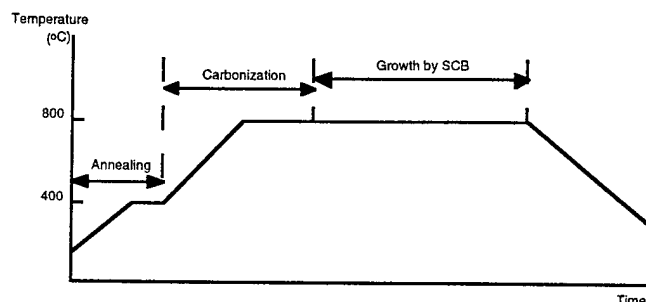

Fig. 8. Temperature program of SiC growth process by MBE.

In this temperature program diagram, there are three parts: (1) Si(100) substrate was heated to 400°C in UHV ( $10^{-10}$  -  $10^{-9}$  torr) with a ramp rate of 20°C/min; (2) the supply of the propane was started and then the substrate temperature was ramped up to 800°C at a rate of 20°C/min; (3) the essential growth of 3C-SiC on the carbonized layer was done at 800°C with SCB for both carbon and silicon source. These growth conditions are summarized in Table 1.

Table 1. Experiment conditions on SiC growth.

#	Substrate	Carbonization by $C_3H_8$				SCB Growth by MBE		
		type	time (min)	pressure (torr)	temp (°C)	time (min)	pressure (torr)	temp (°C)
C21	Si(111) (SOI)	CVD		760	1235	80	$\sim 3 \times 10^{-7}$	1000
C1	Si(100) on-axis	MBE	120	$1.7-4.8 \times 10^{-6}$	776			
CE1	Si(100) on-axis	MBE	20	$1.3-7.1 \times 10^{-6}$	800	9	$1.8-3.7 \times 10^{-6}$	800
CE2	Si(100) on-axis	MBE	120	$1.4-5.1 \times 10^{-6}$	800	95	$1.8-3.5 \times 10^{-6}$	800

The crystallographic features of the growing surface were monitored by the RHEED system. The RHEED images were captured by a CCD camera system, and a sophisticated software (RHEED-VISION) was used to grab the image and monitor up to four diffraction spot intensities during the growth. The thickness and composition of the grown layers were measured by secondary ion mass spectrometry (SIMS) using  $\text{Cs}^+$  bombardment with positive ion detection. Elements monitored were C, Si, O, N and B. Relative sensitivity factors derived from a SiC standard were used to convert ion counts to concentrations. The thickness of SiC layer was estimated by finding the position in carbon depth profile at which atomic carbon concentration is 50% of its maximum. The SCB growth rate was calculated by:

$$\text{growth rate} = \frac{\text{Thickness(total)} - \text{Thickness (carbonized)}}{\text{Time(SCB)}} \quad (1)$$

Propane was supplied by Matheson Gas Products, Inc. with a purity of 99.97%. SCB was provided by Dow Corning. SCB is a liquid at room temperature with a vapor pressure of 400 Torr. Both propane and SCB vapor were used without further purification. Before gas or vapor were introduced into the growth chamber, the cryoshroud was filled with liquid nitrogen, the Ti-sublimation pump and the RGA were turned off to obtain a cleaner growth environment, all cells and gas injector were set to 200°C to avoid their contamination by  $\text{C}_3\text{H}_8$  or SCB. The propane partial pressure during carbonization was  $1.5 - 5.5 \times 10^{-6}$  torr, the SCB partial pressure during growth ranged from 6.1 to  $16 \times 10^{-7}$  torr. The sample was not rotated during the growth in order to be able to monitor the RHEED pattern.

## 4.2 RESULTS AND DISCUSSION

Figure 9 shows a typical RHEED pattern of the 3C-SiC sample (C21) obtained by RTCVD carbonization. This pattern has twin diffraction spots which may be the superposition of two diffraction patterns corresponding to two domains which are 180° rotated from each other. The schematic of this interpretation is shown in Fig. 10. Therefore, the RTCVD carbonized film appears to have double-positioning twin structure. The possible reason of this twin structure is that the Si carbonization is driven by reaction on terraces, different terraces cause the difference in stacking order.

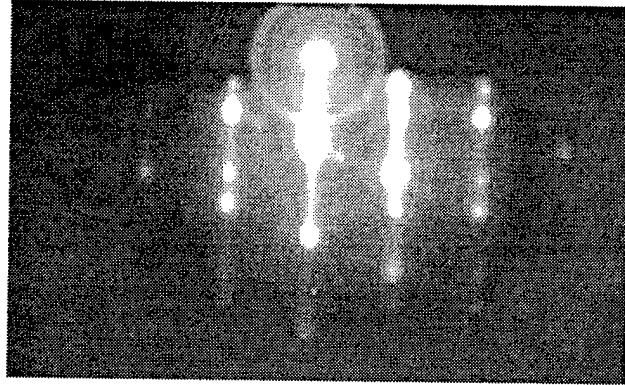

Fig. 9. Typical RHEED pattern of 3C-SiC film by carbonization of SOI with RTCVD.

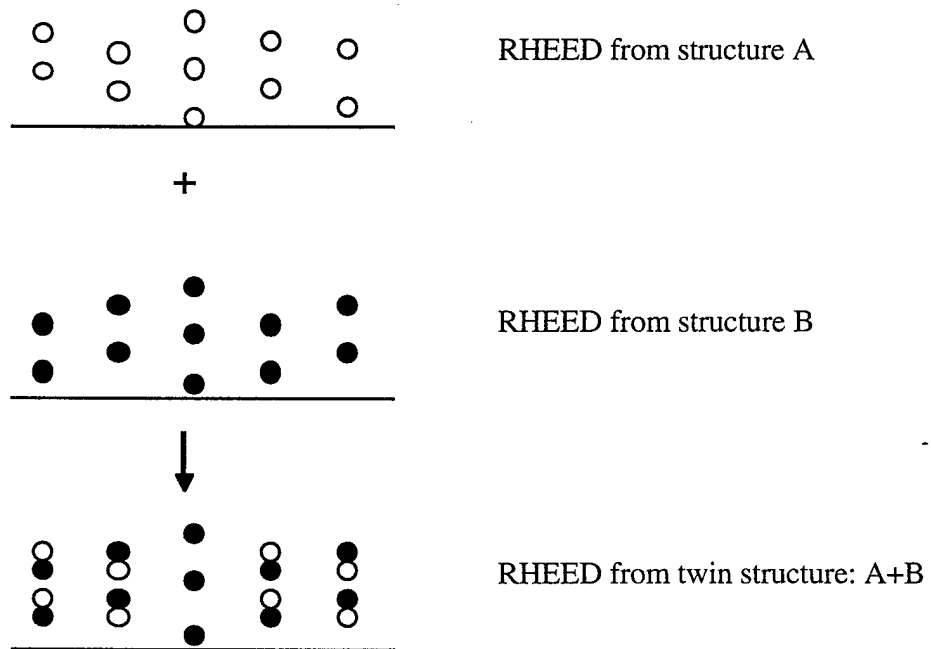

Fig. 10. Interpretation of the RHEED pattern in Fig. 9.

After the carbonization by CVD as shown in Fig. 9, essential growth of SiC was performed in MBE growth chamber with SCB as both Si and C source. During the growth, some fluctuation of intensity was observed. No regular intensity oscillation was observed, probably indicating that the growth was not in a layer-by-layer mode or growth rate is too small. However, the 3C-SiC RHEED pattern was very clear during the entire growth period. Figure 11 shows a RHEED image after 80 min growth at a SCB partial pressure of  $3.0 \times 10^{-7}$  Torr. Compared with the RHEED pattern of Fig. 9, the twin spots in Fig. 11 are much weaker, which probably indicates the double-positioning twin structure is much reduced after essential growth by MBE.

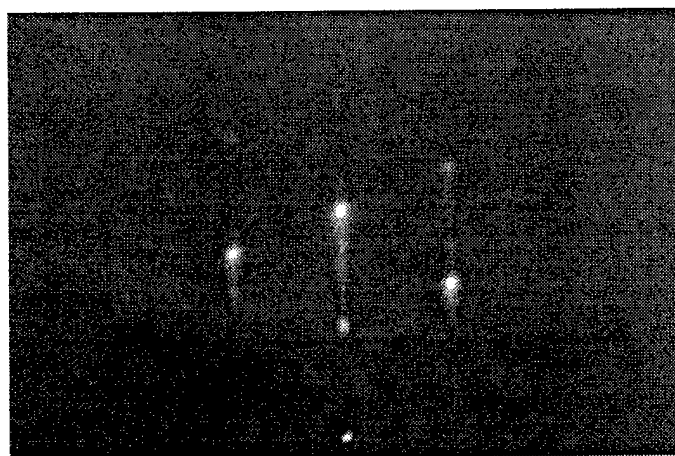

Fig. 11. RHEED pattern of SiC film grown by MBE with SCB.

Carbonization and essential growth were also performed sequentially in MBE system. The substrate was a 2 inch on-axis Si(100) wafer. Figure 12 shows the RHEED patterns observed during SiC growth of sample CE2. Figure 12 (a) is the RHEED pattern of the Si(100) surface after annealing at  $400^{\circ}\text{C}$  for half a hour. The clear streaky pattern indicates a clean Si(100) surface. After introducing propane into the growth chamber, the temperature of substrate was ramped at a rate of  $20^{\circ}\text{C}/\text{min}$ . During this temperature ramping process, the RHEED pattern did not change until  $760^{\circ}\text{C}$ . As the carbonization proceeded, the RHEED pattern associated with 3C-SiC became stronger while that of Si(100) became weaker and finally disappeared. Figure 12 (b) is the 3C-SiC RHEED pattern obtained after 2 hours carbonization of Si(100). No twin spots were observed in the MBE carbonized film as were seen in the carbonized film by RTCVD. This observation indicates that carbonized film by MBE has fewer double-boundary defects than that

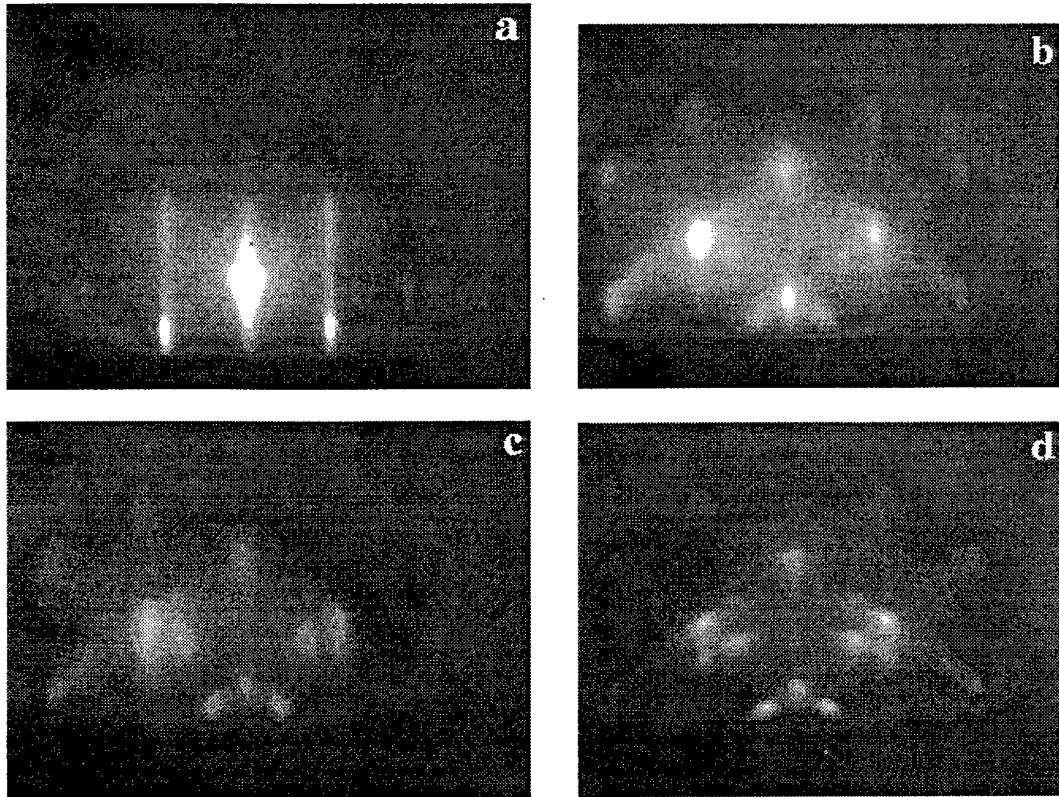

Fig. 12. RHEED patterns observed during SiC growth: (a) clean Si(100) surface at 400°C; (b) 3C-SiC grown by  $C_3H_8$  carbonization for two hours at  $P_{C_3H_8} = \sim 3 \times 10^{-6}$  torr; (c) 3C-SiC grown on the carbonized layer by SCB for 5 min at  $P_{SCB} = 1.4 - 2.9 \times 10^{-7}$  torr; (d) 3C-SiC grown on the carbonized layer by SCB for 95 min at  $P_{SCB} = 1.8 - 3.5 \times 10^{-6}$  torr.

obtained by CVD. The further growth of 3C-SiC was done by introducing SCB at a sample temperature of 800°C. Figure 12 (c) shows the RHEED pattern after 5 min growth by SCB. The pattern looks more streaky than that of carbonized film and indicates the surface is smoother. As growth proceeded, the rings started to appear as shown in Fig. 12 (d), which indicates a polycrystalline SiC film was being formed. The possible reason is that the strain due to the large lattice mismatch between Si and SiC was not completely released by carbonization.

The film composition and thickness of the SiC layers were measured with secondary ion mass spectrometry (SIMS). Figure 13 shows the depth profile of the 3C-SiC film (sample C1)

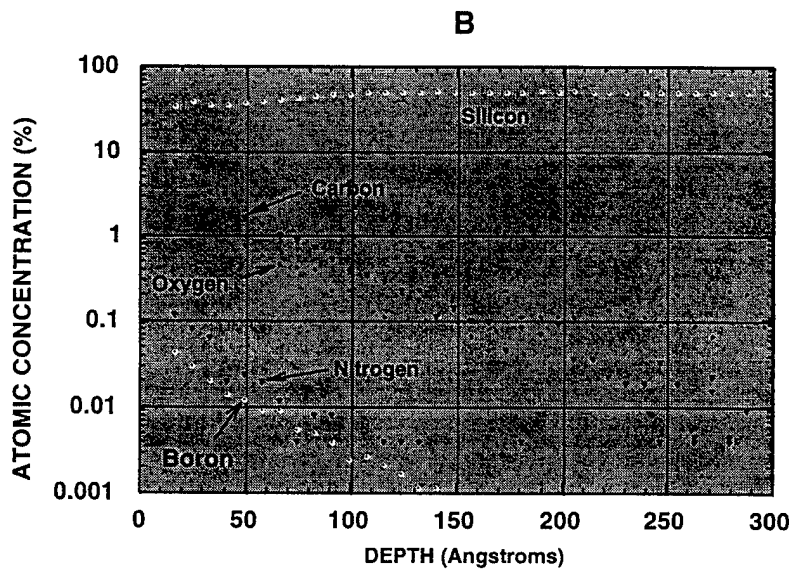
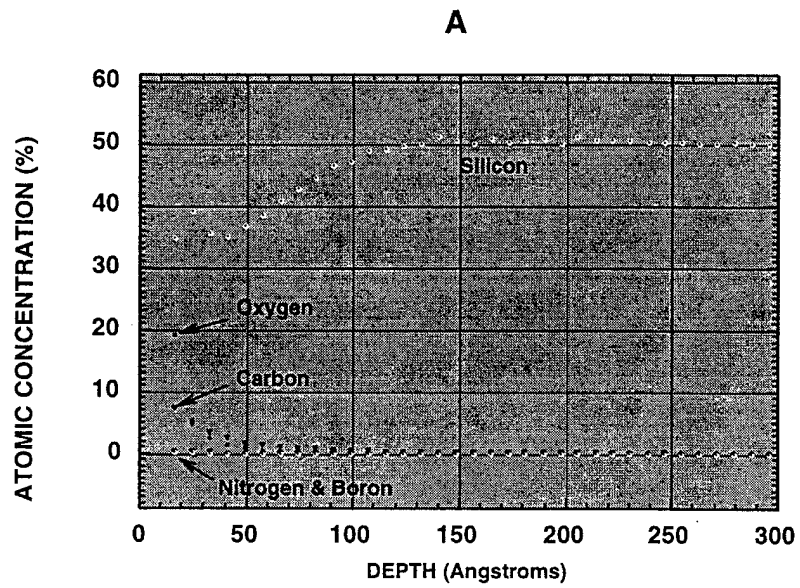

Fig. 13. SIMS depth profile of SiC film (sample C1) grown by two hours carbonization with  $C_3H_8$ . (A): linear scale; (B): Semi-log scale.

grown by MBE carbonization of Si(100) at 776°C for two hours. It is apparent that only a very thin Si layer (probably ~30-40 Å) has been converted at this temperature. It is interesting to point out, however, that even this very thin carbonized layer produced a very good (similar to Figure 12b) RHEED pattern indicative of crystalline SiC. Figure 14 is the depth profile of 3C-SiC film (CE1) grown at 800°C by carbonization for twenty minutes by SCB growth for 9 minutes. The thickness of the SiC film is approximately 95-100 Å judging by the depth at which the carbon concentration reaches the 50% point. Figure 15 shows the depth profile of SiC film (CE2) also grown at 800°C by carbonization for two hours and essential growth by SCB for one hour and 40 min. In this figure, we find that 50% point of carbon in its depth profile occurs at depth of 600 Å, and, therefore, the SiC film thickness is around 600 Å. From the film thickness obtained by SIMS and SCB growth time, the SiC growth rate by SCB at 800°C is estimated to be around 0.1 Å/s. This low growth rate could be due to a combination of effects: low growth temperature, low growth pressure, and, possibly, the fluctuation of the gas flow during gas introduction. In Figs. 14 and 15, a long carbon tail into the Si substrate is observed. This could be caused by several effects: (a) absence of an abrupt interface between SiC and Si substrate, due to carbon atoms diffusing into the Si during growth; (b) non-uniform film thickness resulting in certain locations where the SiC layer is removed sooner during SIMS profiling. The SIMS data also show that impurities N, O and B concentration are less than 1% in the SiC film.

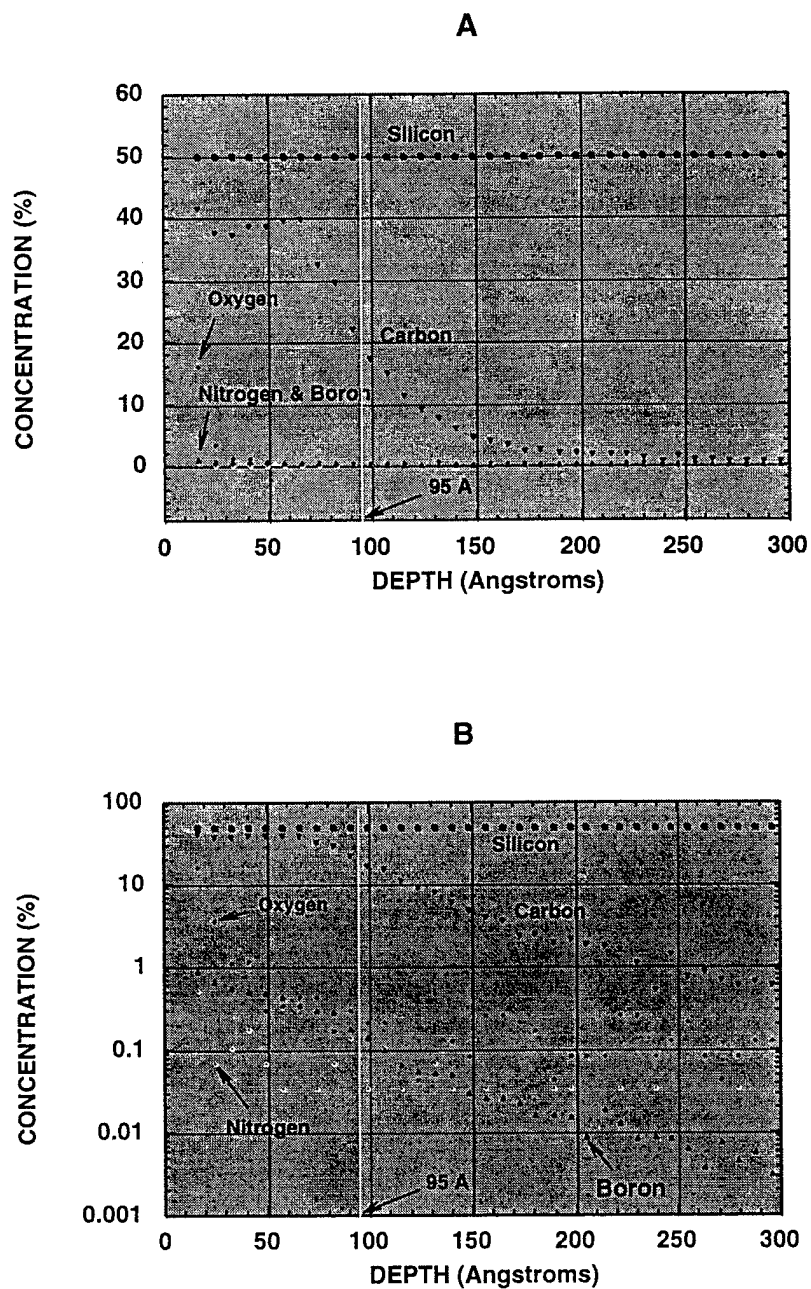

Fig. 14. SIMS depth profile of SiC film (sample CE1) grown by 20 min carbonization and 9 min essential growth by SCB. The SiC film thickness is 95Å. (A): linear scale; (B): Semi-log scale.

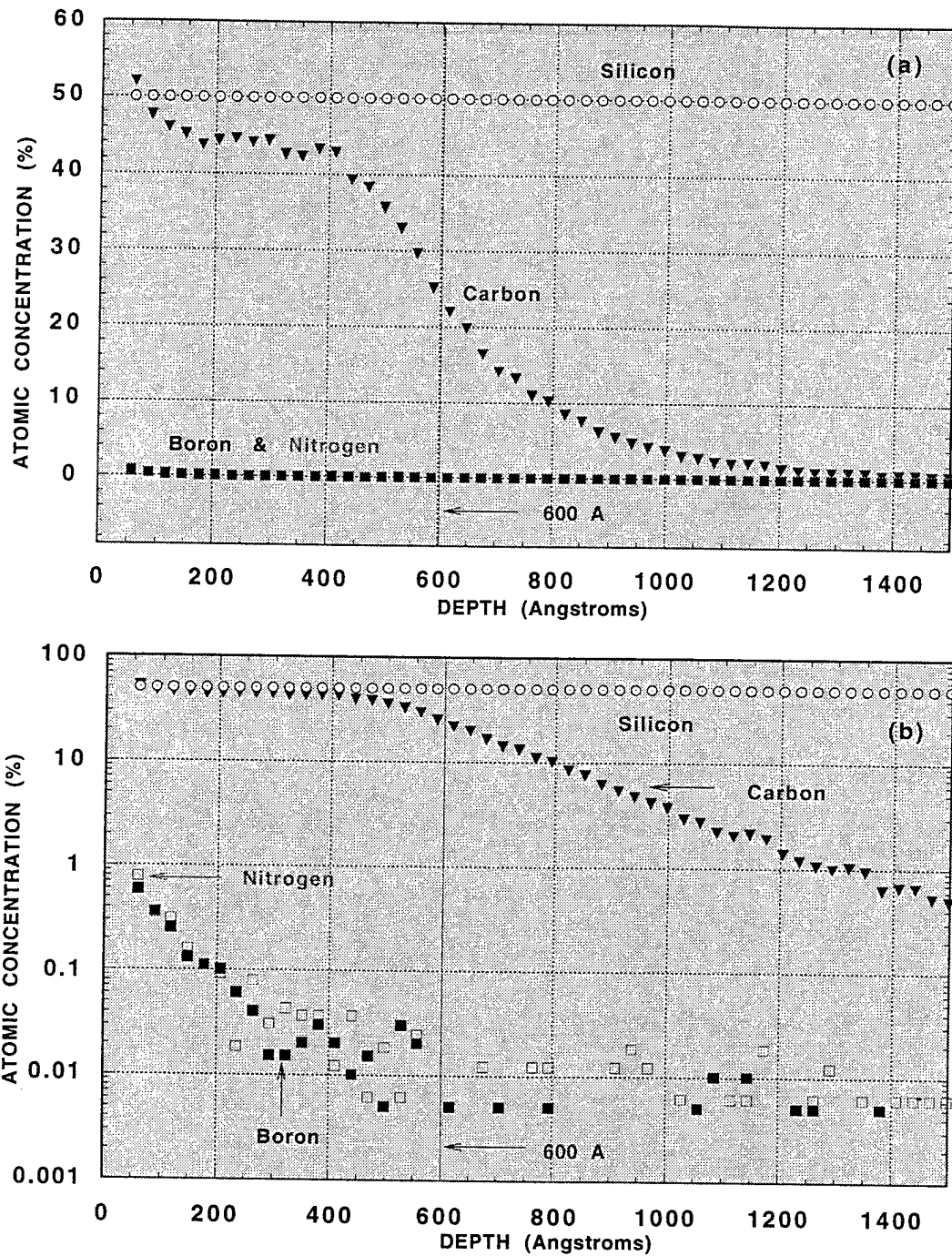

Fig. 15. SIMS depth profile of SiC film (sample CE2) grown by 2 hours carbonization and 1 hour and 40 min essential grown by SCB. The film thickness is 600Å. (A): linear scale; (B): Semi-log scale.

## 5. SUMMARY AND FUTURE WORK

In this report we described the Riber MBE 32 system installed in Nanoelectronics Laboratory at University of Cincinnati. Some preliminary results of heteroepitaxy of SiC by this MBE system were presented. We have clearly demonstrated that SiC growth with SCB can be accomplished by the MBE technique. At 800°C, the SiC growth rate obtained with SCB under the first set of conditions utilized is quite low (0.1 Å/s). We are continuing with experiments designed to determine the effect of growth temperature, pressure and flow rate on the growth process: growth rate and film quality of SiC. We plan to also investigate the use of other gas precursors for SiC growth and the in-situ sequential growth of SiC and GaN. In addition to crystallinity and surface morphology, we will also investigate the electrical and optical properties of the MBE-grown SiC and GaN films.

## 6. REFERENCE

1. W. E. Knippenberg, Philips Res. Rep., **18** (1963) 161.
2. W. E. Nelson, F. A. Halden and A. Rosengreen, J. Appl. Phys., **37** (1966) 333.
3. T. Yoshinobu, T. Fuyuki and H. Matsunami Jpn. J. Appl. Phys, **30** (1991) L1086.
4. T. Yoshinobu, H. Mitsui, Y. Tarui, T. Fuyuki and H. Matsunami, J. Appl. Phys. **72** (1992) 2006.
5. S.-I. Motoyama, N. Morikawa, M. Nasu and S. Kaneda, J. Appl. Phys., **68** (1990) 101.
6. G.L. Zhou, Z. Ma, M. E. Lin, T. C. Shen, L. H. Allen and H. Morkoc J. Crystal Growth, **134** (1993) 167.
7. T. Sugii, T. Aoyama and T. Ito J. Electrochem. Soc., **137** (1990) 989.
8. Kinam Kim, Si-Choi and K.L. Wang, J. Vacuum Sci. Technol. B **10** (1992) 930.
9. Kinam Kim, Si-Choi and K.L. Wang, Thin Solid films, **225** (1993) 235.
10. S.-I. Motoyama, N. Morikawa and S. Kaneda, J. Cryst. Growth **100** (1990) 615.
11. S. Tanaka, R. S. Scott and R.F. Davis, Appl. Phys. Lett. **65** (1994) 2851.
12. S. Motoyama and S. Kaneda Appl. Phys. Lett. **54** (1989) 242.
13. S. Kaneda, Y. Sakamoto, C. Nishi, M. Kanaya and S. Hanai, Jpn J. Appl. Phys. **25** (1986) 1307.
14. T. Fuyuki, T. Yoshinobu and H. Matsunami, Thin solid films, **225** (1993) 225.
15. H. Matsunami, Physica B, **185** (1993) 65.
16. T. Yoshinobu, M. Nakayama, H. Shiomi, T. Fuyuki and H. Matsunami, J. Cryst. Growth, **99** (1990) 520.
17. T. Fuyuki, M. Nakayama, T. Yoshinobu, H. Shiomi and H. Matsunami, J. Cryst. Growth, **95** (1989) 461.
18. L. B. Rowland, R.S. Kern, S. Tanaka and R.F. Davis, J. Mater. Res. **8** (1993) 2753.
19. T. Yoshinobu, H. Mitsui, I. Izumikawa, T. Fuyuki and H. Matsunami, Appl. Phys. Lett., **60** (1992) 824.
20. A. Fissel, B. Schroter and W. Richter Appl. Phys. Lett. **66** (1995) 3182.
21. A. Fissel, U. Kaiser, E. Ducke, B. Schroter and W. Richter, J. Crystal Growth, **154** (1995) 72.
22. A. Fissel, U. Kaiser, K. Pfennighaus, B. Schroter and W. Richter Appl. Phys. Lett. **68** (1996) 1.