

REPORT DOCUMENTATION PAGE

Form Approved
OMB No. 074-0188

Public reporting burden for this collection of information is estimated to average 1 hour per response, including the time for reviewing instructions, searching existing data sources, gathering and maintaining the data needed, and completing and reviewing this collection of information. Send comments regarding this burden estimate or any other aspect of this collection of information, including suggestions for reducing this burden to Washington Headquarters Services, Directorate for Information Operations and Reports, 1215 Jefferson Davis Highway, Suite 1204, Arlington, VA 22202-4302, and to the Office of Management and Budget, Paperwork Reduction Project (0704-0188), Washington, DC 20503

1. AGENCY USE ONLY (Leave blank)		2. REPORT DATE 10 Jan 1997	3. REPORT TYPE AND DATES COVERED Final	
4. TITLE AND SUBTITLE Command Decision Modeling Overview			5. FUNDING NUMBERS N61339-96-D-0002	
6. AUTHOR(S)				
7. PERFORMING ORGANIZATION NAME(S) AND ADDRESS(ES) Lockheed Martin Corporation Information Systems Company 12506 Lake Underhill Road Orlando, FL 32825			8. PERFORMING ORGANIZATION REPORT NUMBER ADST-II-CDRL-023R-9600236A	
9. SPONSORING / MONITORING AGENCY NAME(S) AND ADDRESS(ES) NAWCTSD/STRICOM 12350 Research Parkway Orlando, FL32826-3224			10. SPONSORING / MONITORING AGENCY REPORT NUMBER	
11. SUPPLEMENTARY NOTES				
12a. DISTRIBUTION / AVAILABILITY STATEMENT A - Approved for public release; distribution unlimited.				12b. DISTRIBUTION CODE
13. ABSTRACT (Maximum 200 Words) This research activity examines the current state-of-the-art in modeling the command decision process and implementing such models in software. The primary and initial target application is in automated command agents for DIS/ADS. This report was prepared for the Command Decision Modeling ADST II Delivery Order in accordance with the following documents: <ul style="list-style-type: none"> a) Command Decision Modeling Overview (ADST-II-CDRL-023A-9600236) b) Functional Description of a Command Agent (ADST-II-CDRL-023A-9600237) c) Rule Based Systems (ADST-II-CDRL-023A-9600238) d) Genetic Algorithms and Evolutionary Programming (ADST-II-CDRL-023A-9600239) e) Petri Nets and Colored Petri Nets (ADST-II-CDRL-023A-9600240) f) Neural Networks and Bounded Neural Networks (ADST-II-CDRL-023A-9600241) g) Case-Based Reasoning (ADST-II-CDRL-023A-9600242) 				
14. SUBJECT TERMS Decision; Modeling; STRICOM; ADST-II; Simulation; DIS; DIS/ADS;				15. NUMBER OF PAGES 19
				16. PRICE CODE
17. SECURITY CLASSIFICATION OF REPORT UNCLASSIFIED	18. SECURITY CLASSIFICATION OF THIS PAGE UNCLASSIFIED	19. SECURITY CLASSIFICATION OF ABSTRACT UNCLASSIFIED	20. LIMITATION OF ABSTRACT UL	

DTIC QUALITY INSPECTED 1

**ADVANCED DISTRIBUTED
SIMULATION TECHNOLOGY II
(ADST II)**

DELIVERY ORDER #0018

CDRL AB01

**COMMAND DECISION MODELING
OVERVIEW**



19970505 138

FOR: NAWCTSD/STRICOM
12350 Research Parkway
Orlando, FL 32826-3224
N61339-96-D-0002
DI-MISC-80711

BY: Lockheed Martin Corporation
Martin Marietta Technologies, Inc.
Information Systems Company
12506 Lake Underhill Road
Orlando, FL 32825

DOCUMENT CONTROL INFORMATION

Revision	Revision History	Date
	Original release	7/15/96
A	Incorporated customer comments	1/10/97
-		
-		
-		
-		
-		
-		
-		
-		
-		
-		
-		
-		
-		
-		

Table of Contents

PREFACE	1
1.0 INTRODUCTION	2
2.0 DECISION-AIDING NEEDS	3
3.0 DECISION PROCESS ARCHITECTURE.....	5
3.1 GENERAL CONCEPT.....	5
3.2 THE GENERAL DECISION ARCHITECTURE	6
3.3 SITUATION ASSESSMENT	7
3.4 OPTION ASSESSMENT	9
3.5 THE DECIDER.....	12
3.6 IMPLEMENTATION	13
3.7 EXTERNAL ENVIRONMENT	13
4.0 CONCLUSIONS.....	14
5.0 REFERENCES	15
ACKNOWLEDGMENTS.....	19

PREFACE

This research activity examines the current state-of-the-art in modeling the command decision process and implementing such models in software. The primary and initial target application is in automated command agents for DIS/ADS. This report was prepared for the Command Decision Modeling ADST II Delivery Order in accordance with the following documents:

- a) Command Decision Modeling Overview (ADST-II-CDRL-023A-9600236)
- b) Functional Description of a Command Agent (ADST-II-CDRL-023A-9600237)
- c) Rule Based Systems (ADST-II-CDRL-023A-9600238)
- d) Genetic Algorithms and Evolutionary Programming (ADST-II-CDRL-023A-9600239)
- e) Petri Nets and Colored Petri Nets (ADST-II-CDRL-023A-9600240)
- f) Neural Networks and Bounded Neural Networks (ADST-II-CDRL-023A-9600241)
- g) Case-Based Reasoning (ADST-II-CDRL-023A-9600242)

1.0 INTRODUCTION

An architecture of a general decision process is constructed within the Stimulus, Hypothesis, Options, Response (SHOR) framework of Wohl. The process is decomposed into situation assessment and option assessment phases. The situation assessment process is composed of preprocessor, hypothesis generation, and hypothesis assessment subprocesses, while the option assessment process is composed of criteria, option generation, option processing, and decider subprocesses. The context for the overall decision process is a command and control structure, but the architecture should apply to any decision-making situation.

In this paper we present a general architecture for an Army tactical command and control (C^2) process which will enable the development of computer generated forces (CGF) for use in Distributed Interactive Simulation (DIS). This architecture presents a framework which allows the development of components using the applications of artificial intelligence (AI) and computer-based decision systems. The emphasis is on viewing the C^2 process as a decision process.

This work is based on a framework for tactical decision making which the author developed while on a summer faculty fellowship at the Jet Propulsion Laboratory in support of the Airland Battle Advanced Technology (ABAT) program at JPL [BUON83]. While in the original work, the emphasis was on providing decision support to a human decision maker, this effort is directed to support for computer decision making either under the supervision of a human controller or autonomously. While we retain the point of view that the system is computer-aided decision making with the human as the ultimate decision maker, the extension to an autonomous system is merely that there is no human intervention and that the computer could continue to direct the implementation of the decision it recommends. We refer to the system as a decision making system (DMS) whether it is to be a human decision maker or an autonomous computer decision maker.

In this paper we construct an architecture of a general decision process and discuss how it may represent a typical Army command and control process. This discussion is not definitive but is meant as an initial consideration to stimulate further investigation and definition. This work establishes an architecture within which real C^2 processes may be considered.

2.0 DECISION-AIDING NEEDS

The decision process has been studied by behavioral psychologists [JANI77], mathematicians [VONN44], operations researchers [VONW86, ZELE81], computer scientists [SIMO81], system engineers [GREE86, CACC92, REN 95, SAGE81, WOHL81], and military analysts [BEN-82, VRAN92]. The interest has broadened to include artificial intelligence researchers as we try to design systems for computer aiding of the decision process to respond to the needs of the military, business and the non-military governmental agencies [AZAR86, INGR92, POST90].

In today's world, a decision-making system (DMS) has a continually increasing amount of data available. Exotic sensor systems, global communications systems, and large data base systems provide the DMS with vast amounts of data. These same technologies also produce a quickened world. The decision-maker must respond more quickly; there is less time to make decisions. This presents great pressure for the human decision-maker [BARN81, ATHA83]. These pressures were exemplified by the Vincennes incident [BARR92].

The basic human decision-making capabilities remain limited. Short-term memory, the basis for perception and processing, is limited to two to four chunks of information, and it appears to take five seconds to place a chunk in long-term memory [SIMO81]. There are further difficulties: in retrieving information from long-term memory, response time is variable and cannot be guaranteed, and the information retrieved may be incomplete or altered.

The decision process itself can be conducted in various modes, some of which may be pathological [SAGE81, JANI77]. In a stressful situation it may be desirable to have a normative guide to assist in ensuring properly considered decisions.

Thus, the context for a DMS is established. Computer-based systems may be used to overcome human limitations in short-term memory, in rapid and accurate recall of data and information, and conducting the decision-making process. A framework for performing these tasks is the subject of the remainder of the paper.

An initial work for the Advanced Research Projects Agency (ARPA) examined the opportunity for decision-aiding for Command, Control, and Communication (C³) environments in [NICK77]. They also examined the tactical communication effort [MADN82]. The Army Research Institute developed the Tactical Operations System [LEVI77, WITU80] and considered AI in the context of situation assessment [BEN-82, SAGE82]. The Air Force has examined decision-making models in tactical C² systems [BOET82, LEED79, LEVI82, PATT83, WOHL81], and in airborne information systems [CHU 82]. The Navy has examined the tactical C² process from the anti-submarine warfare (ASW) view [WOHL83a, WOHL83b], the undersea warfare view [DAVI82, DEGR82], the surface warfare view [FUNK82], the airborne view [BARN81], and a

10 January 97

general discussion of man-machine task allocation [RIEG82]. The Office of Naval Research (ONR) sponsored Sage's general survey of decision-aiding processes [SAGE81]. NASA has been interested in the process monitoring function [GREE82, HAMM82, ROUS81], and in decision making in the cockpit of an aircraft [CHAP93]. This is not meant to be a thorough review of current work in the field; it only presents some readily available references in the unclassified literature.

The early significant thread leads from the ARPA survey [NICK77] to the Sage review [SAGE81] to Wohl's establishment of a framework for decision process analysis [WOHL81]. We note that much work in this area was done in the 1980's, but much less in the 1990's. There now appears to be significant interest in applications of AI, but much less in normative decision modeling.

3.0 DECISION PROCESS ARCHITECTURE

3.1 General Concept

The focus of this analysis is on the decision-making process performed by a decision-making unit, which is called the decision-making system or DMS. The unit would normally consist of a leader or commander and one or more assistants or operators and associated equipment. At this stage of the analysis the decision process will be examined without attributing functions or tasks to individuals or machines within the decision unit.

The decision unit is considered to be one subsystem within a hierarchical, multilevel system as shown in Figure 1 [MESA70]. The decision unit receives guidance, represented by h , from its supervisory unit or higher headquarters, and returns status information s . It issues instructions and orders u to its control units which are in contact with the external environment, and receives responses and progress reports r . The control unit actually attempts to influence the external states of nature through efforts m , and receives observables q . The input to the actual contact with the environment is w and the ensuing state of the situation is y .

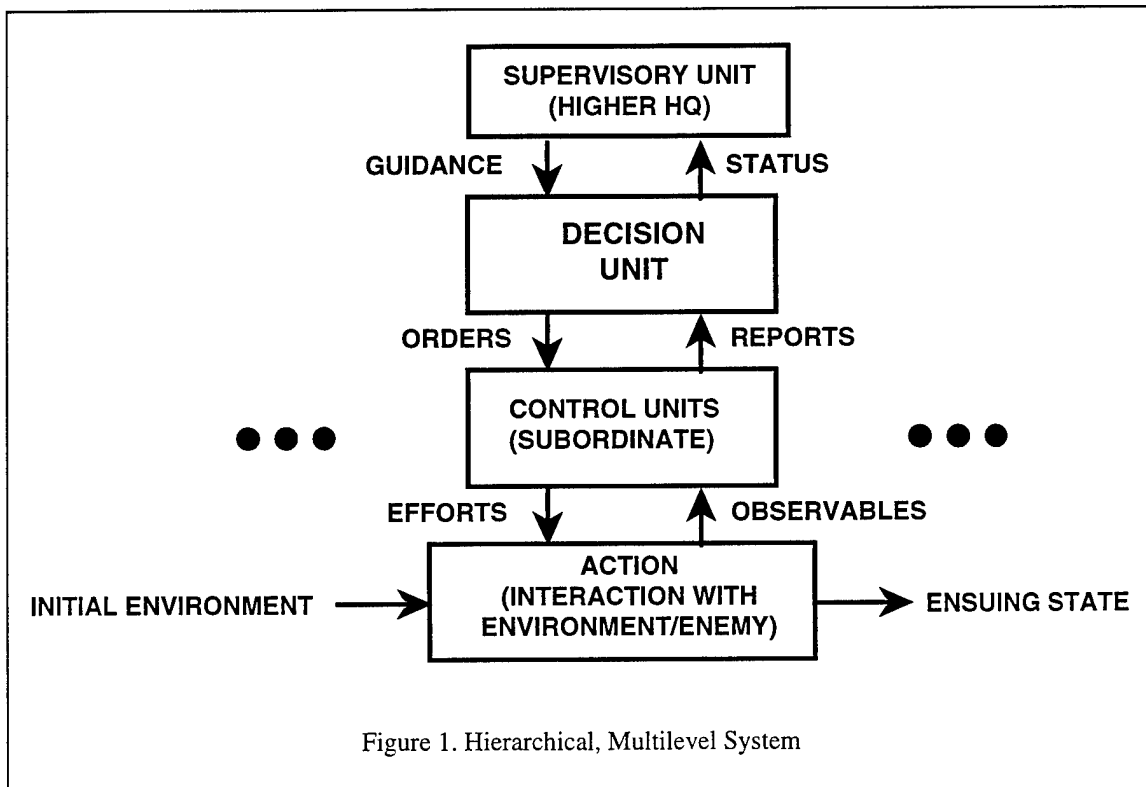
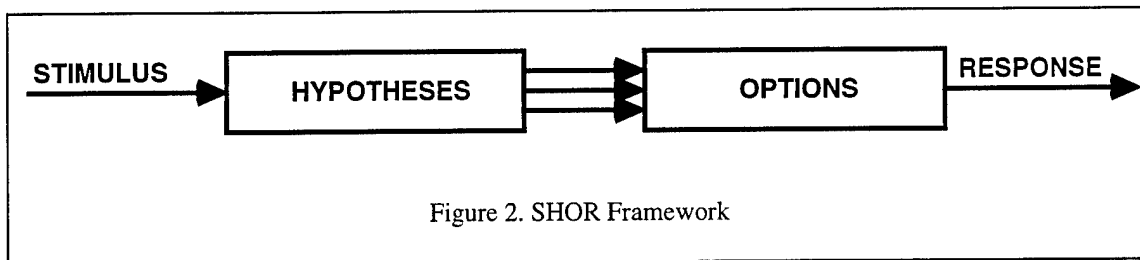

Figure 1. Hierarchical, Multilevel System

10 January 97

While this model represents all of the elements of the decision situation, it is too complex for consideration at this stage. It does, however, establish the context for the view of the decision unit, and the types of interactions with other subsystems and the external environment. Contact with an opposing or enemy force is considered as part of the environment and is represented within the states of nature w and y . Similar views are presented in [LAWS79, ATHA83].

The model of the decision process is based upon the SHOR framework of Wohl, [WOHL81, WOHL83a, WOHL83b] shown in Figure 2. The acronym SHOR stands for stimulus, hypothesis, options, and response. A stimulus (S) is received thereby initiating the decision process. Based upon the stimulus and other information available at that time, various hypotheses (H) are generated concerning the actual situation or the actual state-of-the-world faced by the DMS. In consideration of the various possible situations it may be facing (the hypotheses), the DMS generates a set of options (O) or possible actions which it could direct to be taken. The effects or outcomes of the options are evaluated in view of the uncertain nature of the situation, and the DMS selects the appropriate action or response (R). The response then can be considered to interact with the external system generating additional stimuli which may lead to additional iterations of the process.



Similar frameworks have been developed by other investigators [LAWS79, RASM80, BOET82, DAVI82, ATHA83, LEVI83, RASM83]. While they are based on an assessment-response type of structure, they do include features germane to their investigations and do not provide the same architecture developed in this work.

3.2. *The General Decision Architecture*

For this study the SHOR framework is adapted to produce the decision process architecture illustrated in Figure 3. In this view, data is received by the decision unit or DMS. The DMS conducts a situation assessment process (or sub-process) generating one or more hypotheses of the current situation, H_i . The DMS considers various options in the option assessment process, resulting in an action selected for implementation. For this current effort, no further interaction with the external environment is considered. Consideration will be concentrated on the situation assessment and option assessment subprocesses.

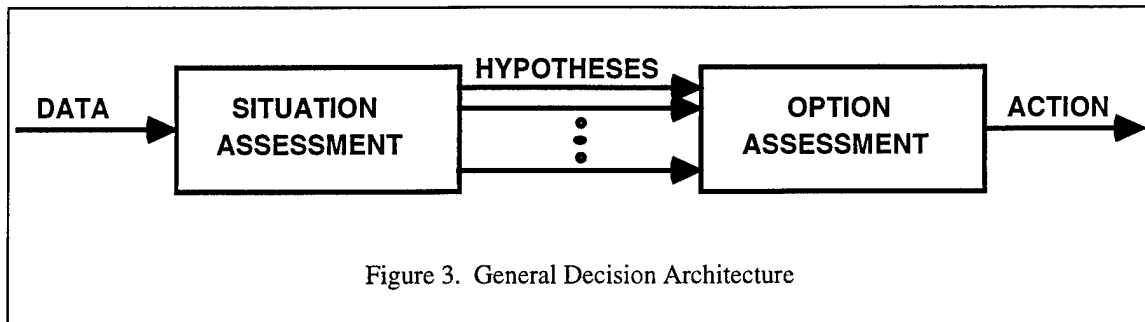

Additionally, the decision process is being modeled as an orderly sequential process. There are obvious opportunities for feedback, simultaneous processing, and jumping ahead in the real process. Consideration of these complications is deferred for subsequent studies.

In the following sections, we will further consider the Situation Assessment and Option Assessment subprocesses.

3.3. *Situation Assessment*

The situation assessment process considers newly acquired data in conjunction with currently available information and generates estimates of the current state of the environment or outside world [BEN82]. Hypotheses, H_i , are developed concerning what is happening. Each of these hypotheses, in turn, generates an interpretation of the state-of-the-world reflected in an estimated state vector x_i . The process also generates a measure of the likelihood of the hypothesis being true which is reflected as $P(H_i | Z)$. This is shown in the form of a conditional probability implying a Bayesian representation, but one may use other paradigms such as a possibility function [DOCK82], or Dempster-Shafer theory.

The concept of the situation assessment subprocess is shown in Figure 4. Incoming data are preprocessed by the Perception Processor to generate a vector Z which is suitable for further processing. Elements of the vector Z may be numerical, logical, or symbolic; whatever is appropriate to represent the input of the external world to the decision-making process. Operations such as calibration, transformation, aggregation, or correlation may occur within the preprocessor. It may use currently active hypotheses to establish the context for the processing. This processor may also include a process to assess the urgency with which the system should consider the situation, or to provide an alerting or bell-ringing function [PATT83, GREE82, WITU82, WOHL83b].

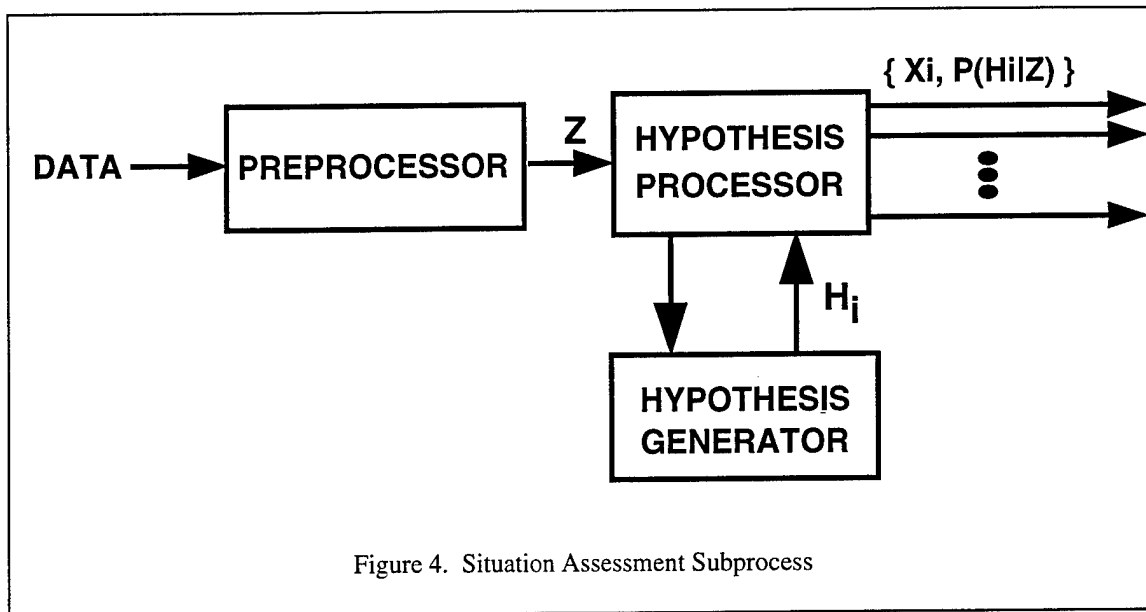

Figure 4. Situation Assessment Subprocess

The stimulus or initiating event for the decision process may be data-driven or concept-driven [WOHL83b]. The data-driven process occurs when specific received data are input to the system and are recognized as a stimuli. The concept-driven process occurs when a hypothesis or concept is presented for consideration, and then data or information is sought to evaluate the concept.

Not much is definitely known about how hypotheses are generated. Some are already in memory and can be brought into active consideration [WOHL83b]. Others may be stimulated by specific features of the data Z . Still others may be created by mental processes leading to possible application of neural networks.

The Hypothesis Processor may be viewed as performing a pattern-matching process (see Figure 5). Each of the current active hypotheses in addition to forming an expected state vector X_i also form an expected view of what the incoming data should be. This expected value of Z under H_i or X_i can be represented as z_i . A pattern-matching process may then generate a set of variations and the decision-maker assess if the matches are satisfactory. If not, then the DMS generates additional hypotheses which are placed in the current hypothesis short-term memory until the DMS is satisfied with the set of hypotheses and state vectors under active consideration.

10 January 97

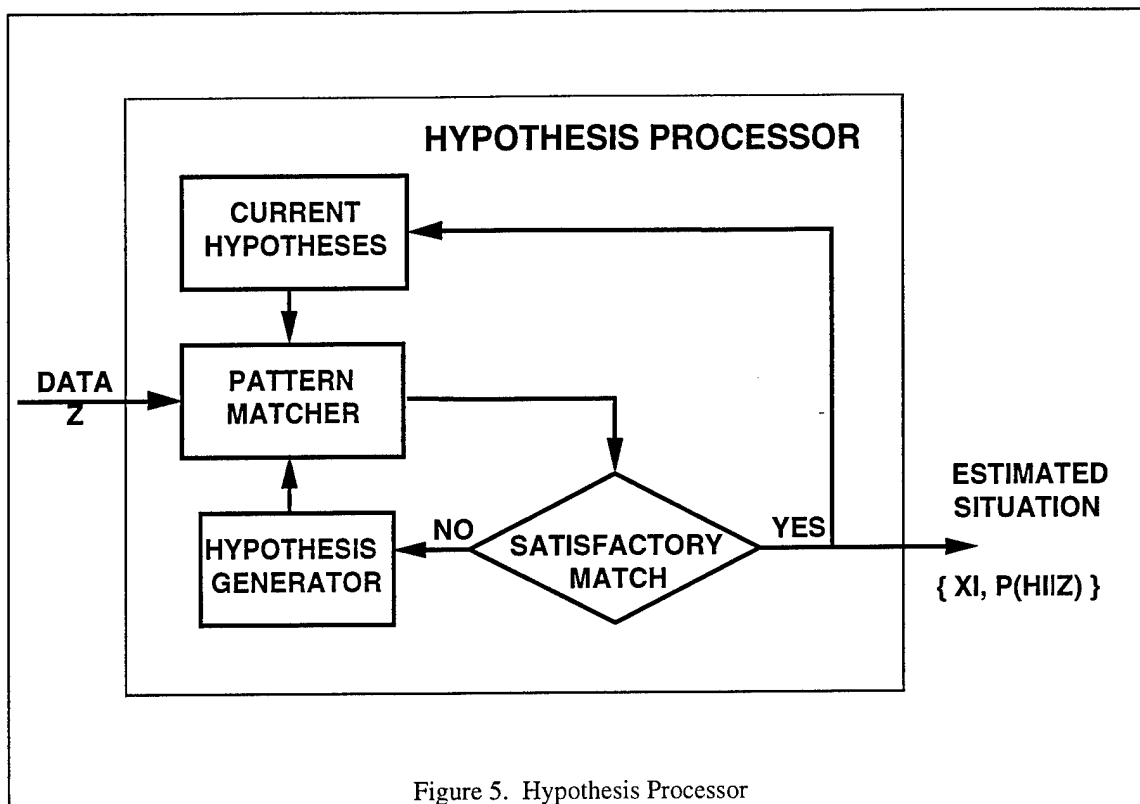

3.4. Option Assessment

The option assessment subprocess uses the hypotheses and the estimates of the situation facing the decision maker system as input, generates and evaluates alternative courses of action available to the DMS, and then selects a course of action for implementation.

This subprocess can be further decomposed into the subprocesses shown in Figure 6. Objectives and criteria are provided to the DMS from higher headquarters, from manuals, procedures, and doctrine, and from the DMS's experience and wisdom. It is assumed that some articulation of these is possible. It is also valuable to have some assessment of the relative importance or value of the objectives, goals, and criteria.

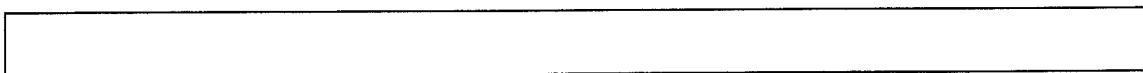

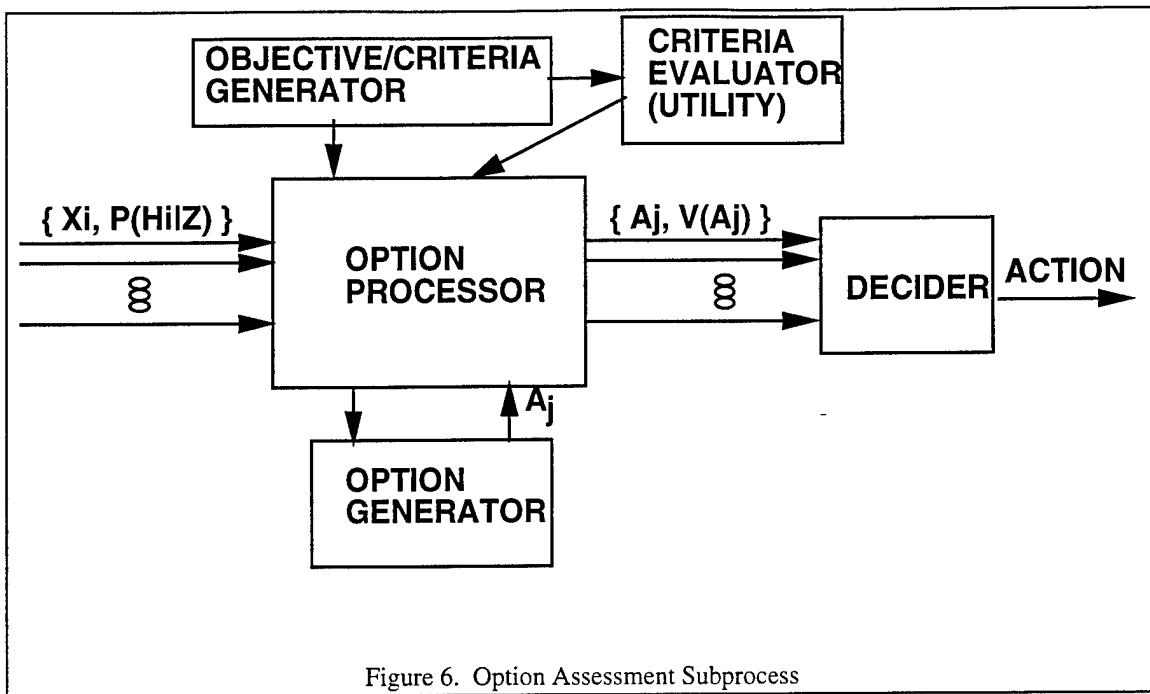

Figure 6. Option Assessment Subprocess

Options or courses of action open to the DMS are available within the memory structure or are provided by the option generator process. Outcomes of the actions under active consideration, a_j , will depend upon the true state-of-the-world, but can be estimated for each of the expected state vectors X_i . The degree to which the possible outcomes of each action meet the goals and objectives may be evaluated considering the relative value of the goals and objectives, and the degrees of belief, probability or possibility of the hypotheses. The nature of this evaluation process cannot be *a priori* defined for any decision-maker, but should allow choice. For this stage of the development it is assumed that some value $V(a_j)$ is available for each action a_j under consideration. This process can be viewed as a continuum of complexity from a simple single-criterion problem to a multi-objective, multi-criteria, nonlinear problem which could be analytically intractable. Whatever the nature of the evaluation process, it is assumed to be captured within the model.

At this point it may be useful to consider the modes of decision-making behavior developed by Rasmussen [HOLL83, RASM83, WOHL83b]. He postulated three decision-making modes: the skill-based mode, the rule-based mode, and the knowledge-based mode. The skill-based mode is characterized by strong habitual behavior. Actions are taken in response to stimuli with little or no conscious effort. This is the reflex action of a skilled operator or practitioner. Actions or decisions made in the rule-based mode are governed by procedures or doctrines. In this case, more effort is required than in the skill-based mode, to find the governing rule or procedure. Once found, however, the appropriate action is determined. Both the skill-based and rule-based modes depend on recognizing the triggering state-of-the-world with sufficient certitude given the urgency of

the situation. The knowledge-based mode requires the DMS to extract appropriate information to deduce the appropriate action. This mode requires the full benefit of this decision model. The expanded Option Processor is shown in Figure 7.

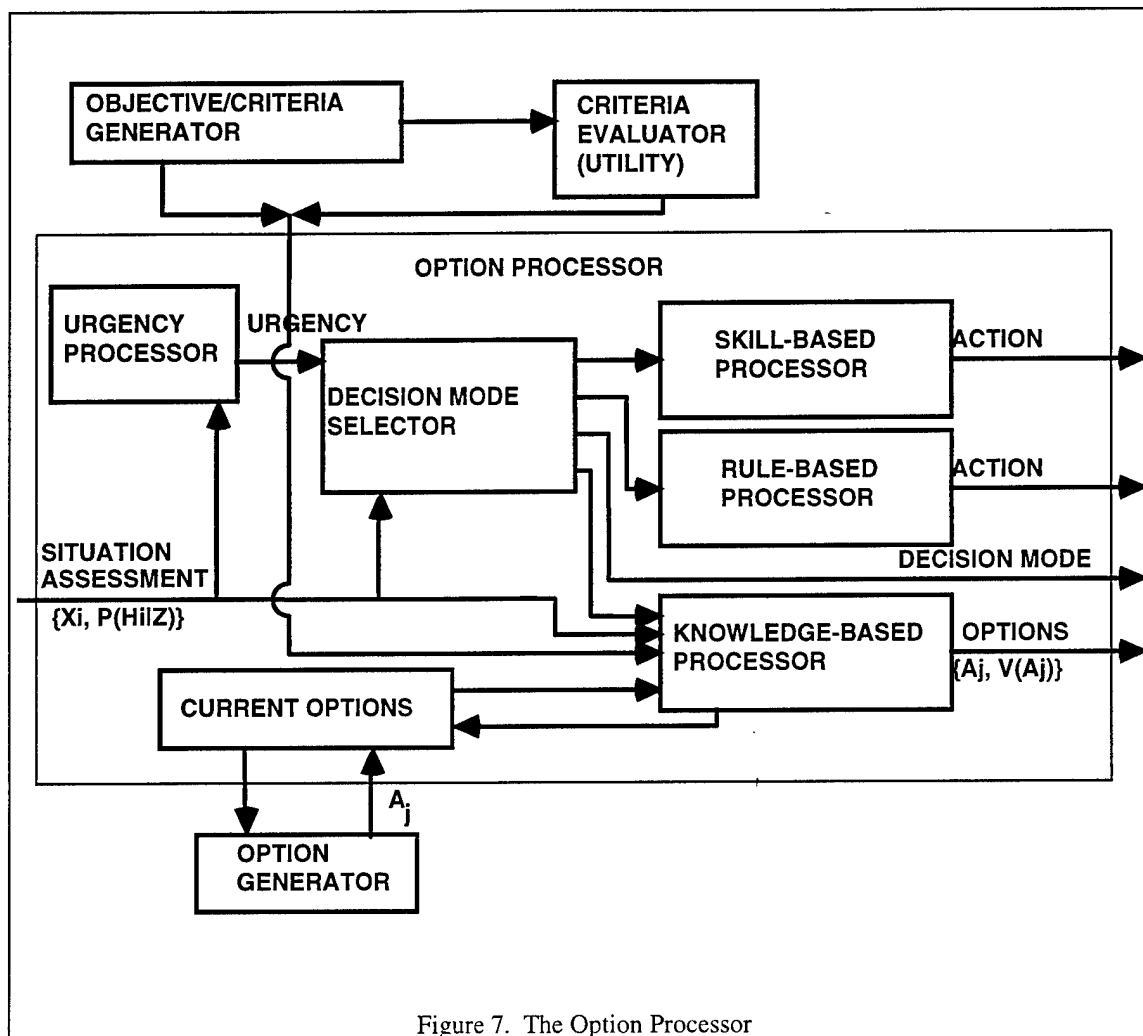

Figure 7. The Option Processor

We should realize that the terms used by Rasmussen do not carry the intention of meaning identical to those which the AI community uses. The blocks in Figure 7 called Rule-Based Processor and Knowledge-Based Processor could be implemented by any appropriate representational model. Not only should rule-based expert systems be considered, but neural networks, model-based systems, genetic algorithms, or others are appropriate candidates.

3.5. The Decider

The processes to this point have been concerned with providing the DMS with the informational and procedural resources to make the decision. The actual selection of an action or the decision is made in the Decider process. This process is represented in Figure 8.

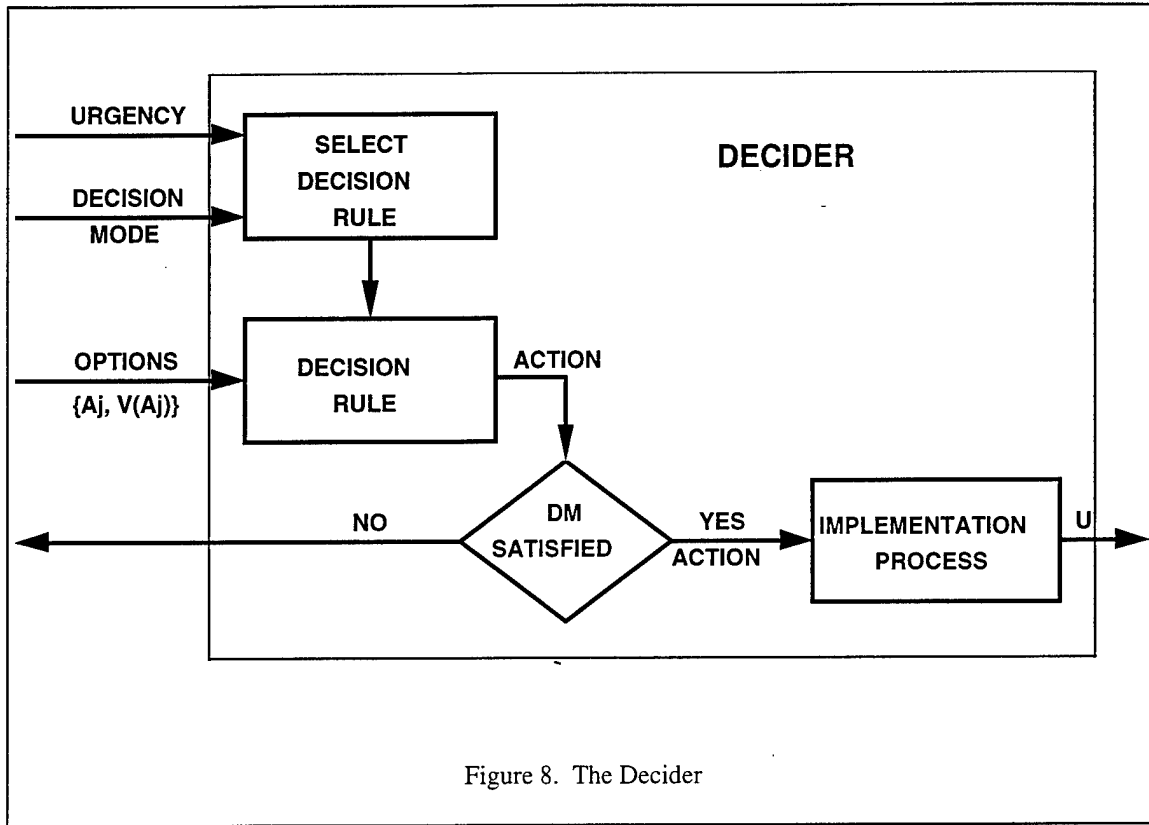

Figure 8. The Decider

In his excellent review article, Sage describes various models of decision-making behavior and effects of stress and complexity [SAGE81]. For this model, it is assumed that as a result of some interaction, a choice is made of decision rule to use, and then the decision rule is applied to select the appropriate action for implementation. In the case of skill-based or rule-based behavior, that action will be already determined. In the case of knowledge-based behavior, one may still select a satisfying decision rule [SIMO81] (also called bounded rationality), a rational actor model, a garbage can model, or some model for making the action selection decision.

Even once this is done, the DMS has one last chance to review the situation and decide if he is really willing to make this decision. If not, the process can cycle back to an earlier stage and go through another iteration. If the DMS is satisfied, it can proceed with implementation. One can go through the decision process and get so caught up with it that some perspective may be lost. This last decision acts as a final check, and, by personal experience, often results in NO result.

We have shown an Urgency variable with input into the Select Decision Mode process. Based on the current hypothesized situation assessment, the Urgency variable will assess a time by which an action should be selected and implemented. The three option processors, the Skill-Based, Rule-Based, and Knowledge-Based Processors will all operate in parallel through blackboard structures so that a "best" action may be selected by the time that it is required.

3.6. Implementation

The implementation process represents converting the selected action into an operable instruction u which will cause some interaction with the external environment. It could represent the issuance of an order or communication. In a complete modeling sense, there may be some further planning necessary to translate the selected action into an executable instruction.

3.7. External Environment

Once the decision is made and appropriate executable instructions issued, there is some interaction with the external environment. The results of that interaction may be sensed and that data input to the process to begin another decision. In that sense the process may be a control process. Of course, the process may be open-ended with no subsequent processing.

At several stages in this model, decisions were made as part of the decision process. Since the model, as developed, is general in scope, it can be nested so that each of the individual decisions could be represented in terms of this model.

4.0 CONCLUSIONS

Department of Defense research agencies, ARPA, NRL, AFOSR, and ARI, have begun to examine decision-making and ways AI can be used to assist in the decision-making process. This work developed a general architecture of a decision process using Wohl's SHOR paradigm (Stimulus, Hypothesis, Options, Response) and carrying the decomposition to more detail than previously done, but consistent with the thrust of the DOD work. The possible use of AI techniques to support the decision processes in the model structure are left to others to discuss. AI provides the promise of tools to help the military decision-maker cope with the increasing mass of data and information and of the decreasing response times of the future battlefield. It may also help to provide the decision-makers the capacity for making better decisions. It will, however, provide capability for autonomous agents for use in simulation systems.

The architecture was constructed within the SHOR paradigm. The process was decomposed into situation assessment and option assessment phases. The situation assessment phase is composed of preprocessor, hypothesis generation, and hypothesis assessment subprocesses. The option assessment phase is composed of criteria, option generation, option processing, and decider subprocesses. The context for the overall decision process is a command and control structure, but the architecture applies to any decision-making situation.

5.0 REFERENCES

- ATHA83 Michael Athans, "System Theoretic Challenges in Military C³ Systems," Naval Research Reviews, Vol. XXXV, No. 2, 1983, pp. 18-28.
- AZAR86 Jerome Azarewicz, "Plan Recognition for Airborne Tactical Decision Making," AAI-86, pp. 805-811.
- BAIL82 Robert W. Bailey, Human Performance Engineering, Prentice-Hall, 1982.
- BARN81 M.J. Barnes, Human Information Processing Guidelines for Decision-Aiding Displays, Naval Weapons Center, China Lake, CA, NWC, Technical Memorandum 4605, December 1981. AD-A124858. N83-02023105.
- BARR92 John Barry and Roger Charles, Newsweek, July 13, 1992, pp. 29-39.
- BASA81 Tamer Basar and Jose B. Cruz, Jr., Concepts and Methods in Multi-Person Coordination and Control, University of Illinois at Urbana-Champaign, Technical Report UILU-ENG-81-2251, R-920(Dc-49), October 1981, 77 pages. AD-A124386.
- BEN82 Moshe Ben-Bassat and Amos Freedy, "Knowledge Requirements and Management in Expert Decision Support Systems for (Military) Situation Assessment," IEEE Trans. Syst., Man, Cybern., Vol. SMC-12, No. 4, pp.479-490, July/August 1982.
- BOET82 Kevin L. Boettcher and Alexander H. Levis, "Modeling the Interacting Decision Maker with Bounded Rationality," IEEE Trans. Syst., Man, Cybern., Vol. SMC-12, No. 3, pp. 334-344, May/June 1982.
- BUON82 Frederick B. Buoni, Decision Support Systems, Appendix L of Computer Science: Key to a Space Program Renaissance, Final Report of the 1981 NASA/ASEE Summer Study on the Use of Computer Science and Technology in NASA, University of Maryland Technical Report 1168, January 15, 1982.
- BUON83 Frederick B. Buoni, A Process Architecture for Computer-Based Decision Support, Florida Institute of Technology working paper, August 1983.
- CACC92 Pietro Carlo Cacciabue, Françoise Decortis, Bartolome Drozdowicz, Michel Masson, and Jean-Pierre Nordvik, "COSIMO: A Cognitive Simulation Model of Human Decision Making and Behaviour in Accident Management of Complex Plants," IEEE Trans. Syst., Man, Cybern., Vol. 22, No. 5, pp. 1058-1074, September/October 1992.
- CHAP93 Alan R. Chappell, Knowledge-Based Reasoning in the Paladin Tactical Decision Generation System, NASA Contractor Report 4507, Lockheed Engineering and Sciences Company, 1993.
- CHU 82 Yee-yeen Chu and Amos Freedy, "Computer-Aided Information Handling in Supervisory Control of Airborne Systems," IEEE 1982 Proc. Conf. Cybern. Soc., pp. 425-429, 1982.
- COMP82 Michael A. Companion and Gregory M. Corso, "Task Taxonomies: A General Review and Evaluation," Int. J. Man-Machine Studies, Vol. 17, No. 8, pp. 459-472, 1982.
- DAVI82 M. Dianne Davis, "Cybernetics in the Submarine Society: The Human Use of High Technology," 1982 Proc. Int. Conf. Cybern. and Soc., pp. 223-227, 1982.

10 January 97

- DEGR82 Edward DeGregorio, Ann Silva, and David Brazil, "Applied Artificial Intelligence in the Submarine Combat Control Environment," 1982 Proc. Int. Conf. Cybern. Soc., pp. 506-510, 1982.
- DOCK82 John T. Dockery, "Fuzzy Design of Military Information Systems," Int. J. Man-Machine Studies, Vol. 16, pp. 1-38, 1982.
- FITT80 Mike Fitter and Max Sime, "Creating Responsive Computers: Responsibility and Shared Decision-Making," in Smith and Green, Ed's, Human Interaction With Computers, Academic Press, 1980, pp. 39-66.
- FUNK82 Ken Funk, "Symbolic Structures and the Human Operator," IEEE 1982 Proceedings of the International Conference on Cybernetics and Society, October 28-30, 1982, pp. 156-160.
- GREE86 Joel S. Greenstein and Mark E. Revesman, "Development and Validation of a Mathematical Model of Human Decisionmaking for Human-Computer Communication," IEEE Trans. Syst., Man, Cybern., Vol. SMC-16, No. 1, pp. 148-154, 1986.
- GREE82 Joel S. Greenstein, and William B. Rouse, A Model of Human Decision-making in Multiple Process Monitoring Situations, IEEE Trans. Syst., Man, Cybern., Vol. SMC-12, No. 2, pp. 182-193, 1982.
- HAMM82 John M. Hammer and William B. Rouse, "Design of an Intelligent Computer-Aided Cockpit," 1982 Int. Proc. Conf. Cybern. Soc., pp. 449-453.
- HOLL83 Erik Hollnagel, "What We Do Not Know About Man-Machine Systems," Int. J. Man-Machine Studies, Vol. 18, No. 2, pp. 135-143, 1983.
- INGR92 Francois F. Ingrand, Michael P. Georgeff and Anand S. Rao, "An Architecture for Real-Time Reasoning and System Control," IEEE Expert, pp. 34-44, December 1992.
- JANI77 Irving L. Janis and Leo Mann, Decision Making: A Psychological Analysis of Conflict, Choice and Commitment, Free Press (MacMillan) 1977.
- JOHN82 Scott Kevin Johnson, An Investigation of a Land Combat Tactical Commander's Decision-Making Process, Naval Postgraduate School Thesis, October 1982. AD A124990.
- LAWS79 Joel S. Lawson, Jr., "Naval Tactical C³ Architecture 1985-1995," Signal, Vol. 33, No. 10, August 1979, pp. 71-76.
- LEED79 D. K. Leedom, "Representing Human Thought and Response in Military Conflict Simulation Models," in Symp. on Modelling and Simulation of Avionics Syst. and Command. Contr. and Com. Syst., AGARD (NATO) Conf. Proc., No. 268, Nat. Tech. Inform. Ser., Oct. 15-19, 1979.
- LEVI77 Robert A. Levit, Berton J. Heaton, David G. Alden, "Development and Application of Decision Aids for Tactical Control of Battlefield Operations: Decision Support in a Simulated Tactical Operations System (SIMTOS)," Honeywell Systems and Research Center, Minneapolis, MN, ARI Technical Report TR-77-A13, December 1977, AD A121413.

- LEVI82 Alexander H. Levis, Elizabeth R. Ducot, Michael Athans, Distributed Decision and Communication Problems in Tactical USAF Command and Control, Laboratory for Information and Decision Systems (MIT), July 30, 1982. Technical Report LIDS-IR-1226, AFOSR-TR-82-0952. AD A121413.
- LEVI83 Alexander H. Levis and Kevin L. Boettcher, "Decisionmaking Organizations with Acyclical Information Structures," IEEE Trans. Syst., Man., Cybern., Vol. SMC-13, No. 3, May/June 1983, pp. 384-391.
- MADN82 Azad M. Madni, Michael G. Samet, and Amos Freedy, "A Trainable On-Line Model of the Human Operator in Information Acquisition Tasks," IEEE Trans. Syst., Man., Cybern., Vol. SMC-12, No. 4, pp. 504-511, July/August 1982.
- MESA70 M. D. Mesarovic, D. Macko, and Y. Takahara, Theory of Hierarchical, Multilevel Systems, Academic Press, 1970.
- NICK77 R. S. Nickerson, M. J. Adams, R. W. Pew, J. A. Swets, S. A. Fidell, C. E. Feehrer, D. B. Yntema, D. M. Green. The C³ System User Vol. I: A Review of Research on Human Performance as it Relates to the Design and Operation of Command, Control and Communication Systems. Bolt Beranek and Newman, Inc. Technical Report 3459, Feb. 1977, AD-A126633.
- PATT83 Krishna R. Pattipati, David L. Kleinman, and Arye R. Eprath, "A Dynamic Decision Model of Human Task Selection Performance," IEEE Trans. Svst., Man. Cybern., Vol. SMC-13, No. 3, pp. 145-166, March/April 1983.
- POST90 Stephen Post and Andrew P. Sage, "An Overview of Automated Reasoning," IEEE Trans. Syst., Man. Cybern., Vol. 20, No. 1, pp. 202-224, January/February 1990.
- RASM80 Jens Rasmussen, "The Human as a Systems Component," in Smith and Greed (Ed's), Human Interaction with Computers, Academic Press, 1980.
- RASM83 Jens Rasmussen, "Skills, Rules, and Knowledge: Signals, Signs, and Symbols, and Other Distinctions in Human Performance Models," IEEE Trans. Svst., Man. Cybern., Vol. SMC-13, No. 3, pp. 257-266.
- REN 95 Jie Ren and Thomas B. Sheridan, "An Adaptive Decision Aid for Real Environments," IEEE Trans. Syst., Man, Cybern., Vol. 25, No. 10, pp. 1384-1391, October 1995.
- RIEG82 Christine A. Rieger and Joel S. Greenstein, "The Allocation of Tasks Between the Human and Computer in Automated Systems," in IEEE 1982 Proceedings of the International Conference on Cybernetics and Society, October 28-30, 1982, pp. 204-208.
- ROUS81 William B. Rouse, "Human-Computer Interaction in the Control of Dynamic Systems," Computing Surveys, Vol. 13, No. 1, pp. 71-99, March 1981.
- SAGE81 Andrew P. Sage, "Behavioral and Organizational Considerations in the Design of Information Systems and Processes for Planning and Decision Support." IEEE Trans. Syst., Man, Cybern., Vol. SMC-11, No. 9, pp. 640-678, September 1981.
- SAGE82 Andrew P. Sage and Adolfo Lagomasino, "Knowledge Representation and Interpretation in Decision Support Systems," IEEE 1982 Proc. Conf. Cybern. Soc., pp. 658-662, 1982.
- SIMO81 Herbert A. Simon, The Sciences of the Artificial. Second Edition. MIT Press, 1981.

- VONN44 John Von Neumann and Oskar Morgenstern, The Theory of Games and Economic Behavior, Princeton, 1944.
- VONW86 Detlof Von Winterfeldt and Ward Edwards, Decision Analysis and Behavioral Research, Cambridge University Press, 1986.
- VRAN92 Sanja Vranes, Mario Lucin, Mladen Stanojevic, Violeta Stevanovic and Pero Subasic, "Blackboard Metaphor in Tactical Decision Making," European Journal of Operational Research, Vol. 61, pp. 86-97, 1992.
- WITU80 Gary Witus, Robert W. Blum, Mark Graulich, Description of the Tactical Operations System Information Flow Model, Vector Research, Inc. Report VRI-ARI-3-FR79-3, 30 November 1979, ARI Research Note 80-13, AD-A092206, May 1980.
- WITU82 Gary Witus, Robert W. Blum, Information Flow Management for Distributed Tactical Command Control Systems, IEEE Trans. Syst., Man, Cybern., Vol. SMC-12, No. 4, pp. 512-518, 1982.
- WOHL81 Joseph G. Wohl, "Force Management Decision Requirements for Air Force Tactical Command and Control," IEEE Trans. Syst., Man, Cybern., Vol. SMC-11, No. 9, pp. 618-639, September 1981.
- WOHL83a Joseph G. Wohl, E. E. Entin, M. G. Alexandridis, J. S. Eterno, Toward a Unified Approach to Combat System Analysis, Alphatech, Inc. Technical Report TR-151, January 1983, ADA124570.
- WOHL83b Joseph G. Wohl, E. E. Entin, J. S. Eterno, Modeling Human Decision Processes in Command and Control, Alphatech, Inc. Technical Report TR-137, January 1983, AD A125218.
- ZELE81 Milan Zeleny, Multiple Criteria Decision Making, McGraw-Hill, 1981.