

FINAL REPORT ON ONR CONTRACT N00014-93-1-0069:

“SURFACE DISCHARGE - PUMPED XeF(C→A) LASER”

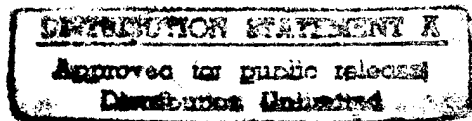

Prepared for

Office of Naval Research  
and  
U.S. Air Force  
Phillips Laboratory  
Lasers and Imaging Directorate  
Kirtland AFB, NM 87117-5776

Prepared by

J. G. Eden  
University of Illinois  
Department of Electrical and Computer Engineering  
1406 West Green Street  
Urbana, IL 61801

June 1996

19970513 065

THIS QUALITY INSURE

# DISCLAIMER NOTICE

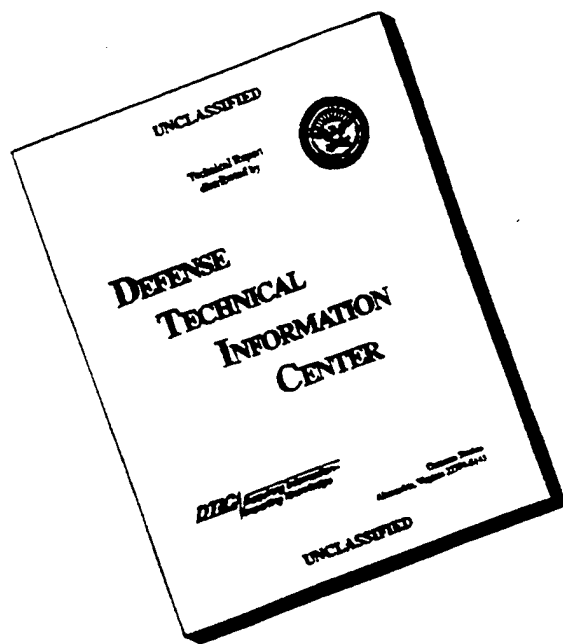

**THIS DOCUMENT IS BEST QUALITY AVAILABLE. THE COPY FURNISHED TO DTIC CONTAINED A SIGNIFICANT NUMBER OF PAGES WHICH DO NOT REPRODUCE LEGIBLY.**

REPORT DOCUMENTATION PAGE			FORM APPROVED OMB No. 0704-0188	
1. AGENCY USE ONLY (Leave blank)	2. REPORT DATE June 1996	3. REPORT TYPE AND DATES COVERED Final Report 1 Nov 1992 - 31 Oct 1995		
4. TITLE AND SUBTITLE OF REPORT Surface Discharge - Pumped XeF(C→A) Laser			5. FUNDING NUMBERS N00014-93-1-0069	
6. AUTHOR(s) J. G. Eden				
7. PERFORMING ORGANIZATION NAME(S) AND ADDRESS(ES) University of Illinois Department of Electrical and Computer Engineering 1406 West Green Urbana, IL 61801			8. PERFORMING ORGANIZATION REPORT NUMBER:	
9. SPONSORING/MONITORING AGENCY NAME(S) AND ADDRESS(ES) Department of the Navy Office of the Chief of Naval Research 800 North Quincy St., Code 1511:CRF Arlington, VA 22217-5000			10. SPONSORING/MONITORING AGENCY REPORT NUMBER: and US Air Force Phillips Laboratory Lasers and Imaging Directorate Kirtland AFB, NM 87117-5776	
11. SUPPLEMENTARY NOTES:				
13. ABSTRACT (Maximum 200 words)  A compact (~1 m <sup>2</sup> footprint), surface discharge-pumped laser system has been developed and applied to excitation of the XeF(C→A) laser in the blue-green (λ~485 nm) and the iodine 1.315 μm transition. Having an active length of 50 cm, this device dissipates >8 MW per cm of discharge length and requires no high voltage or high current switches. With this system and unoptimized optical cavity output coupling, >50 mJ has been obtained on the XeF(C→A) band in ~1 μs pulses. More than 0.75 J was generated on the iodine line of 1.315 μm by photodissociating C <sub>3</sub> F <sub>7</sub> I with the discharge in the presence of Ar, N <sub>2</sub> , and SF <sub>6</sub> . Two electrode configurations for the surface discharge were developed during the course of this work and studies of erosion of the dielectric surface were carried out.				
14. SUBJECT TERMS laser, surface discharge, visible, infrared, photodissociation			15. NUMBER OF PAGES: 26	
			16. PRICE CODE	
17. SECURITY CLASSIFICATION OF REPORT Unclassified	18. SECURITY CLASSIFICATION OF THIS PAGE Unclassified	19. SECURITY CLASSIFICATION OF ABSTRACT Unclassified	20. LIMITATION OF ABSTRACT UL	

FINAL REPORT ON ONR CONTRACT N00014-93-1-0069:

“SURFACE DISCHARGE - PUMPED XeF(C→A) LASER”

Prepared for

Office of Naval Research  
and  
U.S. Air Force  
Phillips Laboratory  
Lasers and Imaging Directorate  
Kirtland AFB, NM 87117-5776

Prepared by

J. G. Eden  
University of Illinois  
Department of Electrical and Computer Engineering  
1406 West Green Street  
Urbana, IL 61801

June 1996

## I. INTRODUCTION

The focus of this Phillips Laboratory - supported research program is the development of a compact, surface discharge device suitable for pumping a variety of atomic and molecular lasers. This effort met all of the goals set forth in the original proposal, and, in general, proved to be quite fruitful. Specifically, the following accomplishments were realized:

- a. A surface discharge device, having an active length of 0.5 m and a footprint  $< 1 \text{ m}^2$  was designed and constructed. This system provides for power dissipations exceeding 10 MW/cm of discharge length and yet includes no high voltage or high current switches;
- b. Laser pulse energies  $> 0.75 \text{ J}$  on the  $1.315 \text{ }\mu\text{m}$  transition of iodine were obtained by photodissociating  $\text{C}_3\text{F}_7\text{I}$  in the presence of a buffer gas mixture ( $\text{Ar}/\text{N}_2/\text{SF}_6$ ) with the surface discharge;
- c. Lasing in the blue-green ( $\lambda \sim 485 \text{ nm}$ ) was also obtained by photodissociating  $\text{XeF}_2$  vapor; pulse energies  $> 50 \text{ mJ}$  were obtained for cavity output couplings of only 5%;
- d. Erosion of a glass ceramic surface was measured with a microstylus to be  $< 0.3 \text{ }\mu\text{m}$  - shot<sup>-1</sup> for the first several tens of shots and to *decrease* thereafter.

An initial report of these results was published in *Optics Letters* (Vol. 20, p. 1011, 1995) and greater detail regarding the construction and operation of the device will be provided here.

## II. EXPERIMENTAL RESULTS

The development of the surface ("open") discharge as an optical pumping source for atomic and molecular lasers was vigorously pursued by a group at the Lebedev Physical Institute (Moscow) in the 1970's and 80's. Their efforts resulted in the demonstration of large pulse energies on the  $\text{XeF}(\text{C} \rightarrow \text{A})$  transition in the blue-green, but the systems were large and confined to low repetition rates. Our goal was to, in collaboration with the Russian group, develop a much more compact and reliable system. Figure 1 shows the system design parameters. Of greatest concern was the elimination of all high current

## SYSTEM DESIGN

### Design Parameters:

- **Low Voltage Operation (25-30 kV)**
- **Elimination of high current switches**
- **Eliminate requirement to fire sections independently – no timing jitter; reliable triggering**
- **Energy stored: 1.5 – 2 kJ (upgraded to 4 kJ)**
- **Active length: ~ 0.5 m**
- **Low inductance**
- **Exchange of gas mixture at least 3 times between pulses**
- **XeF<sub>2</sub> Compatibility**
- **Scalability (length)**

switches which, in the low impedance systems of interest here, are capable of consuming considerable power. As a result of considerable design and testing of several discharge configurations, the design illustrated in Figure 2 was developed. The discharge path is divided by molybdenum pins into segments, most of which are ~12.5 mm in length, and each Mo pin is resistively and capacitively ballasted. This approach eliminates the need for high current switching because the system is triggered by applying a negative 50 kV pulse to the first gap. Thus, the design philosophy is similar to that for a Marx bank in which, after the initial gap is triggered, the remaining gaps follow in succession. The gap between the first two pins is chosen to "hold-off" 30 kV but the gap (1.25 cm) between the remaining Mo electrodes in the series was chosen so that all of the gaps will self-break at 30 kV. Consequently, the application of the 50 kV pulse to the second electrode causes the first gap to close and the voltage at pin #2 rises rapidly to the full supply voltage. Therefore, the second gap quickly breaks down and all remaining gaps follow in succession. A major advantage of this design is that the individual gaps are not triggered independently; consequently, the jitter of the system is low. Figure 3 is a detailed schematic diagram of the laser head.

This device produces surface discharges that are reproducible and intense. A photograph illustrating the discharge path is shown in Figure 4. Considerable effort was invested in minimizing the inductance of the system and a current waveform, representative of those observed for this system, is presented in Figure 5. Note that ringing in the waveform has virtually been eliminated which demonstrates that the impedances of the power generator and the discharge are nearly matched. Approximately 80% of the energy stored in the capacitor bank is deposited in the discharge in the first half-cycle of the current waveform. Power depositions in the discharge exceeding  $10 \text{ MW-cm}^{-1}$  have been achieved to date with this system.

Once the system had been characterized from an electrical standpoint, optical gain and lasing experiments were conducted for both the XeF(C $\rightarrow$ A) band as well as the atomic

## SIMPLIFIED ELECTRICAL SCHEMATIC

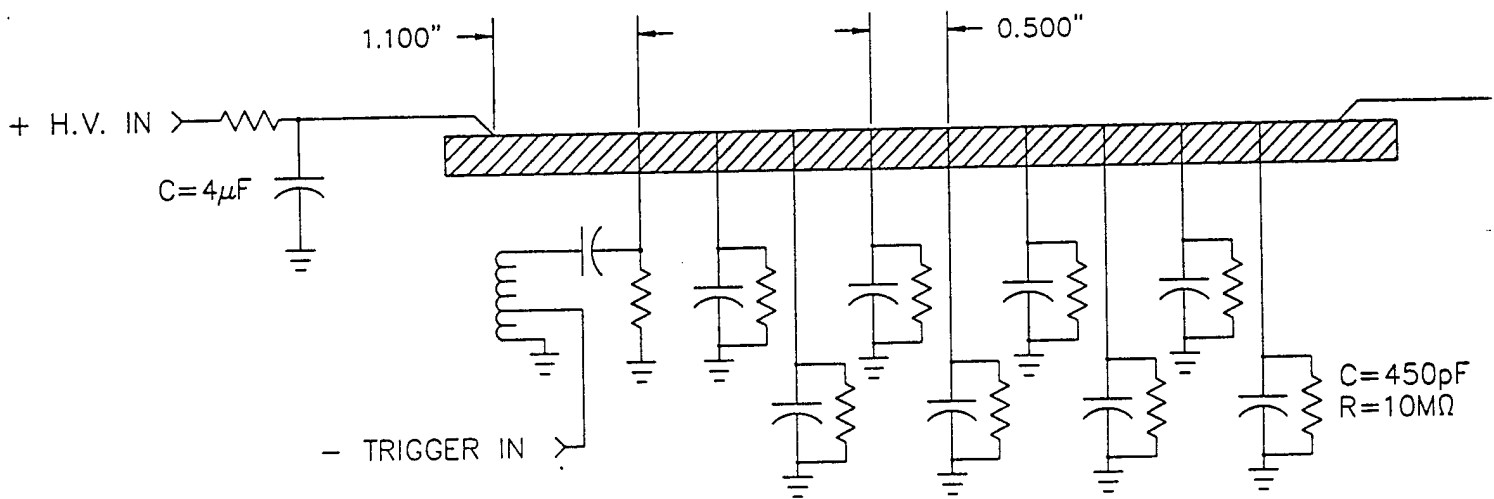

Distance from H.V. electrode to first pin designed  
to hold off 30kV

Distance between all other electrodes will self-break  
at 30kV

Trigger pulse applied to first pin  $\sim -50\text{kV}$  (trigger  
input =  $-18\text{kV}$ )

Intermediate pins spatially confine discharge and  
allow long distances at low voltages

FIG. 2

LASER HEAD PLAN VIEW

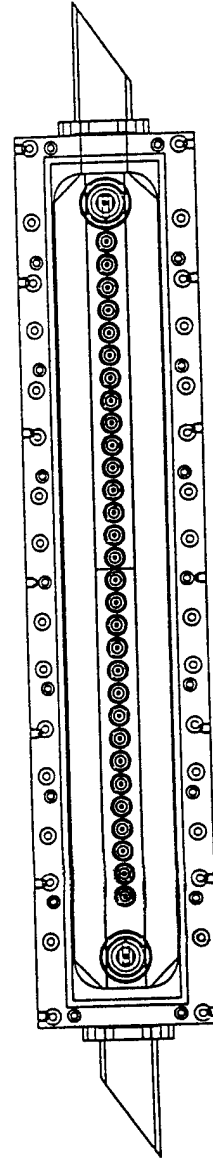
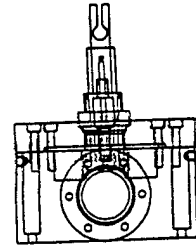
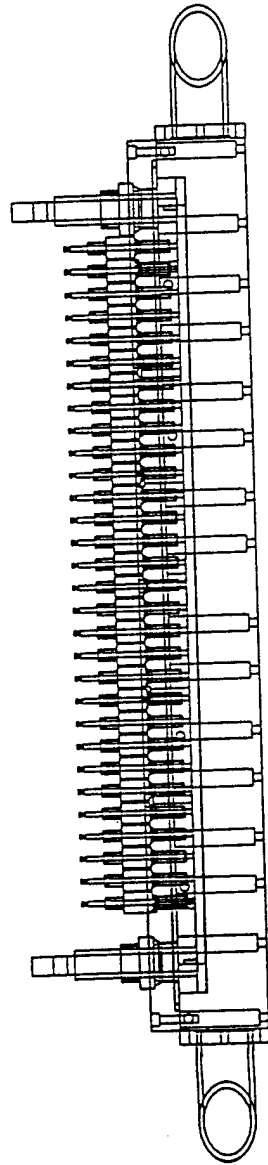

FIG. 3

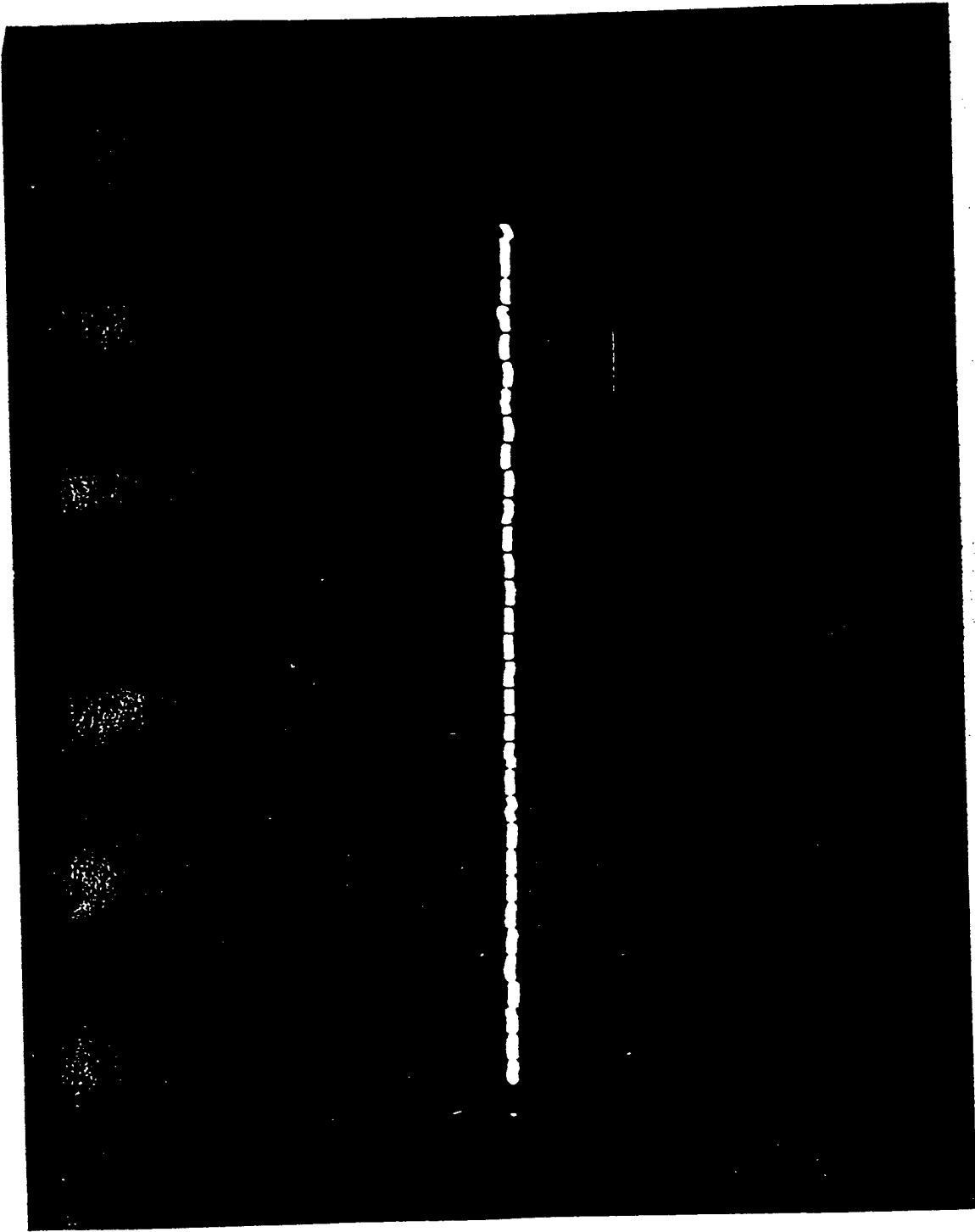
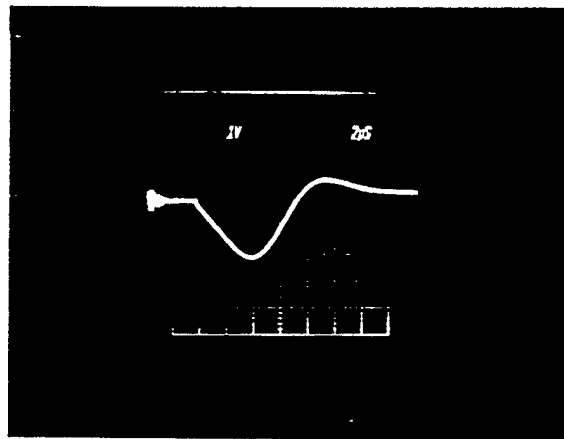

FIG. 4

## ELECTRICAL PERFORMANCE

Current  
Waveform



- $\sim 1.8$  kJ deposited in first half-cycle  
(30 kV, 4  $\mu$ F) :  $\sim 80\%$  OF STORED ENERGY
- Power deposition: 8 MW – cm<sup>-1</sup>
- Impedance of power generator and discharge nearly matched
- Peak current > 50 kA

FIG. 5

iodine laser (1.315  $\mu\text{m}$ ). Figure 6 is a diagram showing the experimental arrangement for conducting gain measurements on the C $\rightarrow$ A band of XeF in the blue-green. A double pass system was employed and the gain probe was provided by an Ar ion laser. A particular line was selected for study with the aid of a diffraction grating and typical gain and lasing waveforms are given in Figure 7. For a mixture of 520 Torr Ar, 190 Torr N<sub>2</sub>, and 2.4 Torr XeF<sub>2</sub>, strong fluorescence is observed in a pulse of  $\sim 2$   $\mu\text{s}$  FWHM. When an optical cavity consisting of a high reflector ( $> 99.9\%$ ) and an output coupler having a transmission of 1-2% at 480 nm is installed, lasing is observed in a pulse of  $\sim 1.2$   $\mu\text{s}$  FWHM. As illustrated in Figure 8, the laser spectrum is broad ( $\sim 15$  nm FWHM) and the only noticeable features arise from absorption by excited states of atomic xenon.

Measurements of the XeF(C $\rightarrow$ A) pulse energy as a function of the gas mixture and cavity output coupling were made and the results are summarized in Figure 9. Pulse energies up to 53 mJ were obtained for an output coupling of 5% and estimates suggest that the optimal output coupling should be considerably higher (20-30%). Maximum output power was obtained for XeF<sub>2</sub> partial pressures of  $\sim 1.7$  Torr.

These results are quite consistent with those obtained with much larger systems. Figure 10 is a log - log plot of the C $\rightarrow$ A output energies (joules) that have been reported in the literature. It is interesting to note that the highest energies (obtained at the Lebedev Physical Institute, Moscow) correspond to an *overall* conversion efficiency of 1%.

A second design for the discharge electrodes was subsequently adopted and engineering drawings of the design are presented in Figures 11 and 12. In this case, the **Mo pins are not introduced through the surface dielectric** but rather through the wall of the laser chamber. This modification not only simplifies the fabrication of the surface dielectric but also strengthens the system against electrical breakdown.

# GAIN PROBING: EXPERIMENTAL APPARATUS

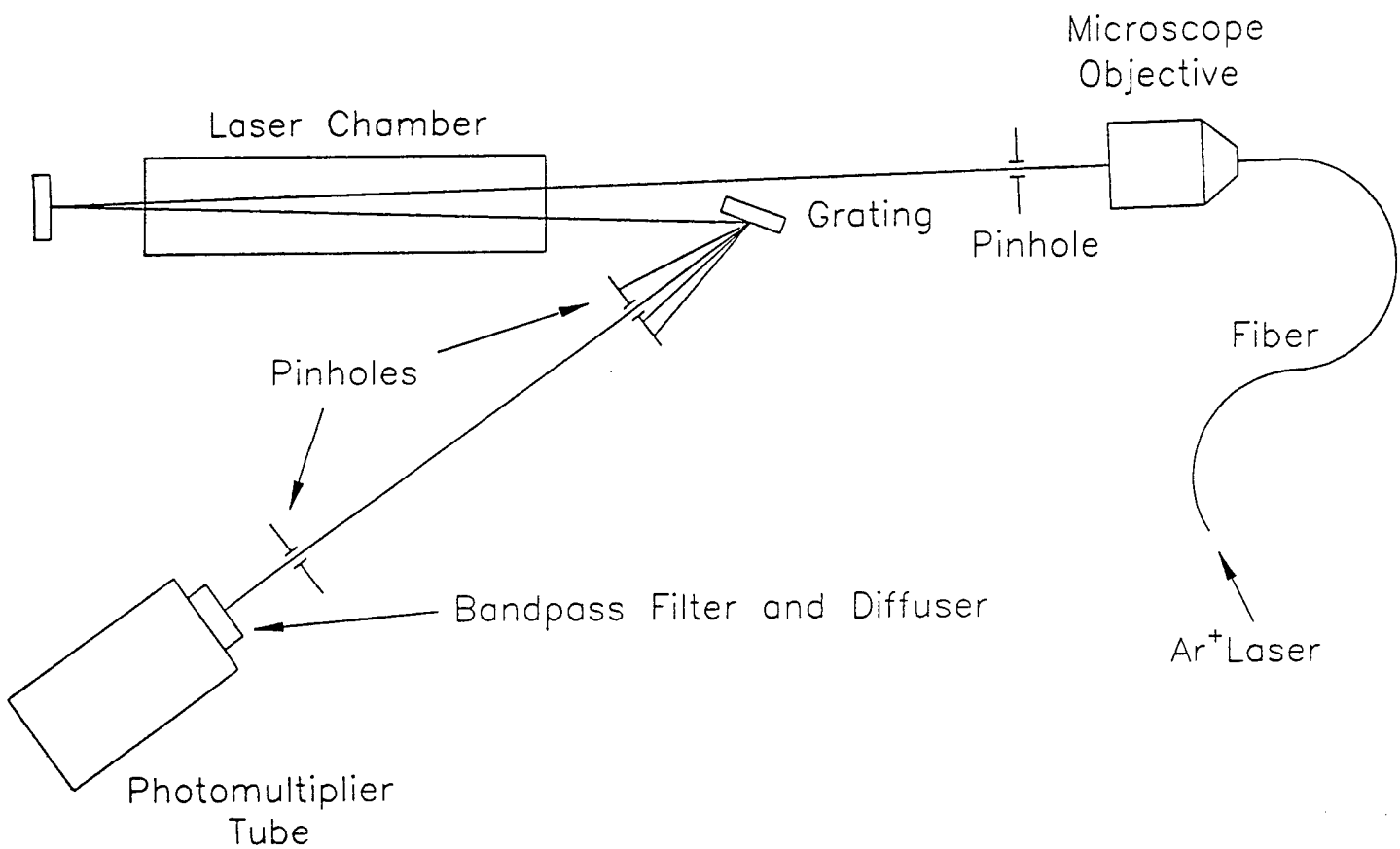
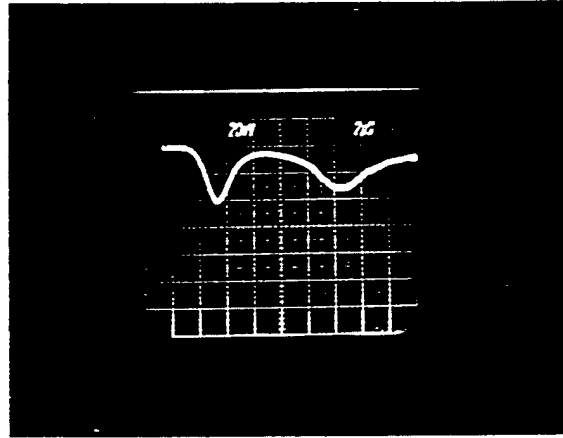

FIG. 6

## XeF(C→A) LASING

570 Torr Ar/  
190 Torr N<sub>2</sub>/  
2.4 Torr XeF<sub>2</sub>



FLUORESCENCE

Ar/N<sub>2</sub>/  
2.3 Torr  
XeF<sub>2</sub>

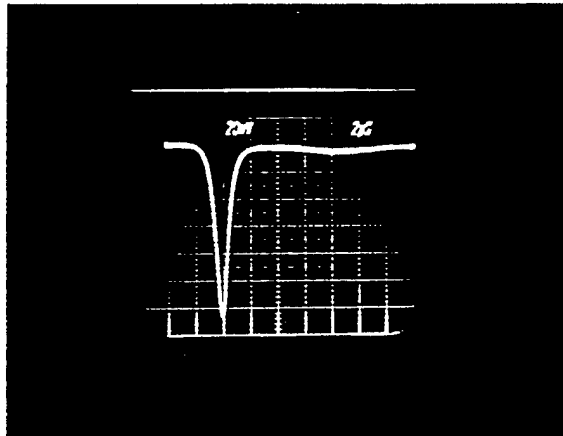

ATTENUATED  
LASER  
WAVEFORM  
T = 1-2%  
at 480 nm

FWHM ~ 1.2 μsec

Mirrors: Flat, 5 m RC

FIG. 7

# XeF (C→A) LASER SPECTRUM

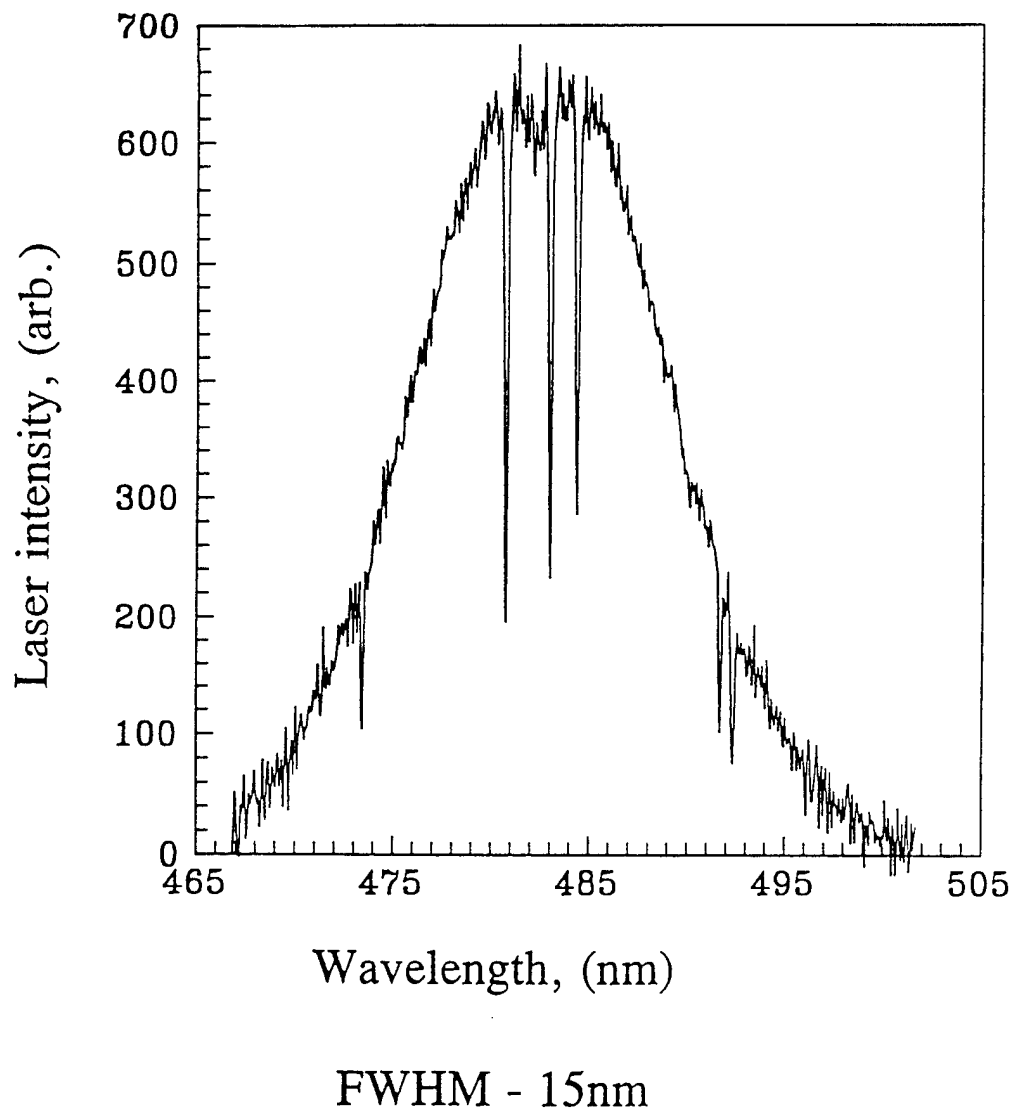

FIG. 8

## XeF (C→A)

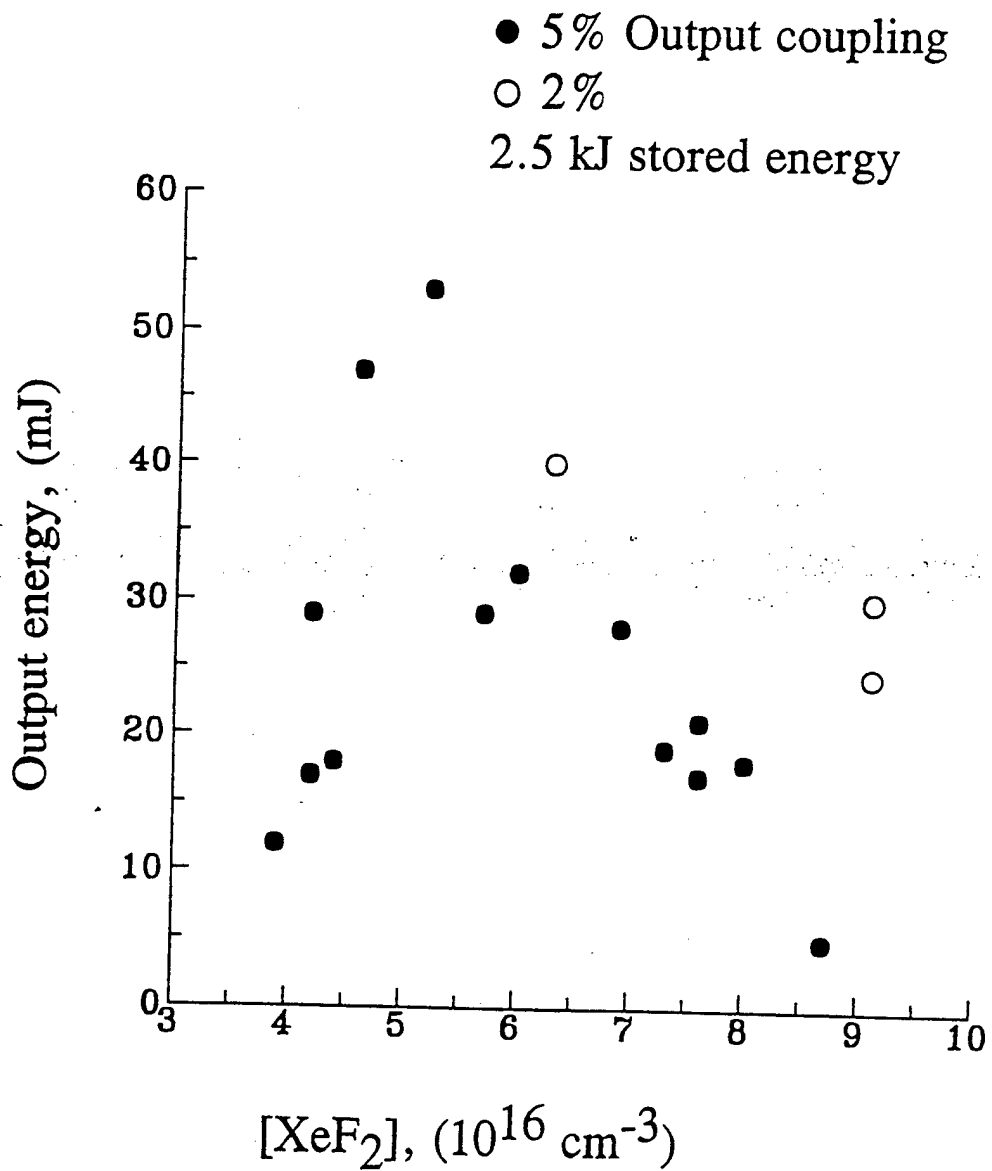

FIG. 9

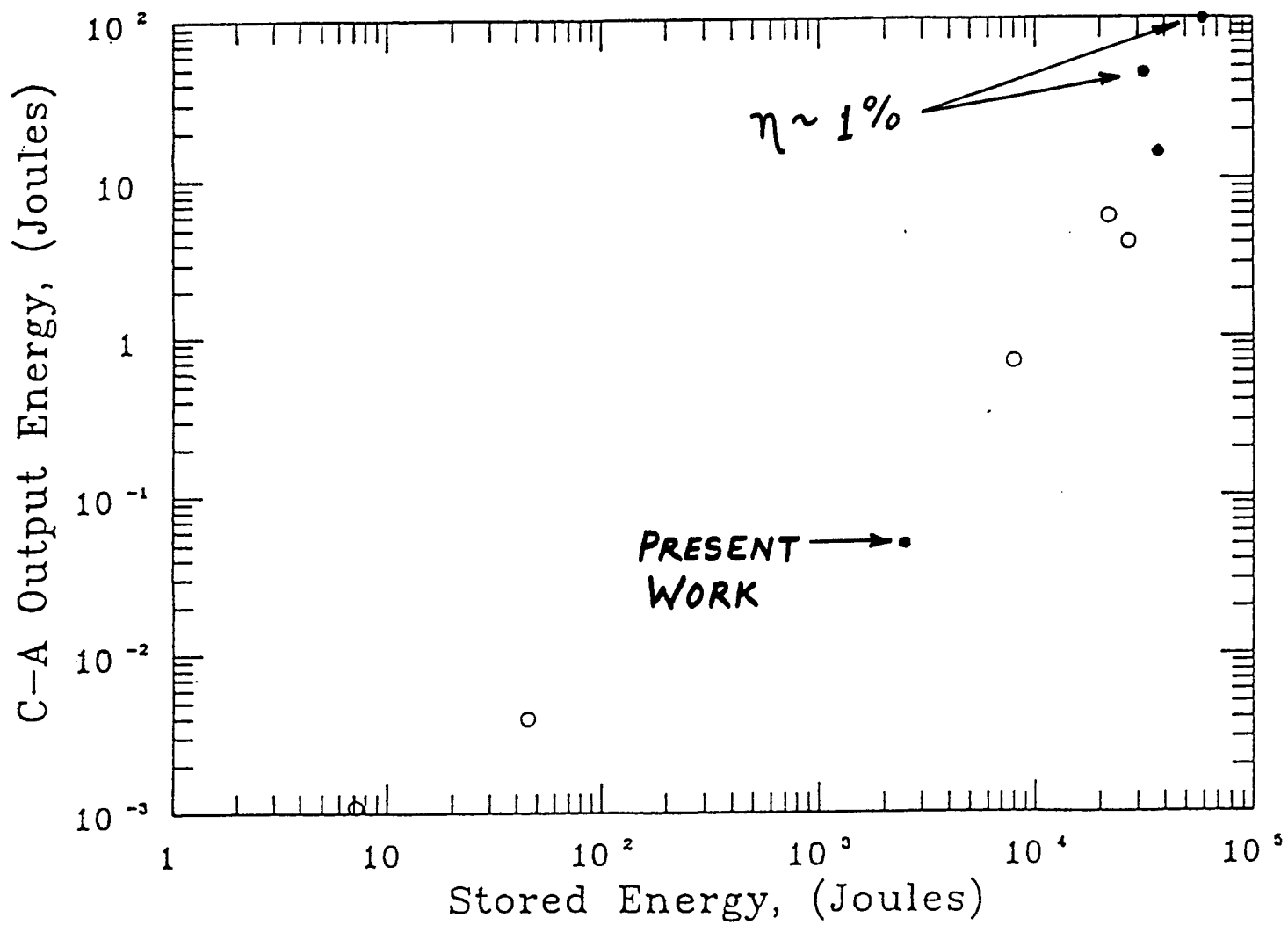

FIG. 10

LASER HEAD —  
REVISED DESIGN

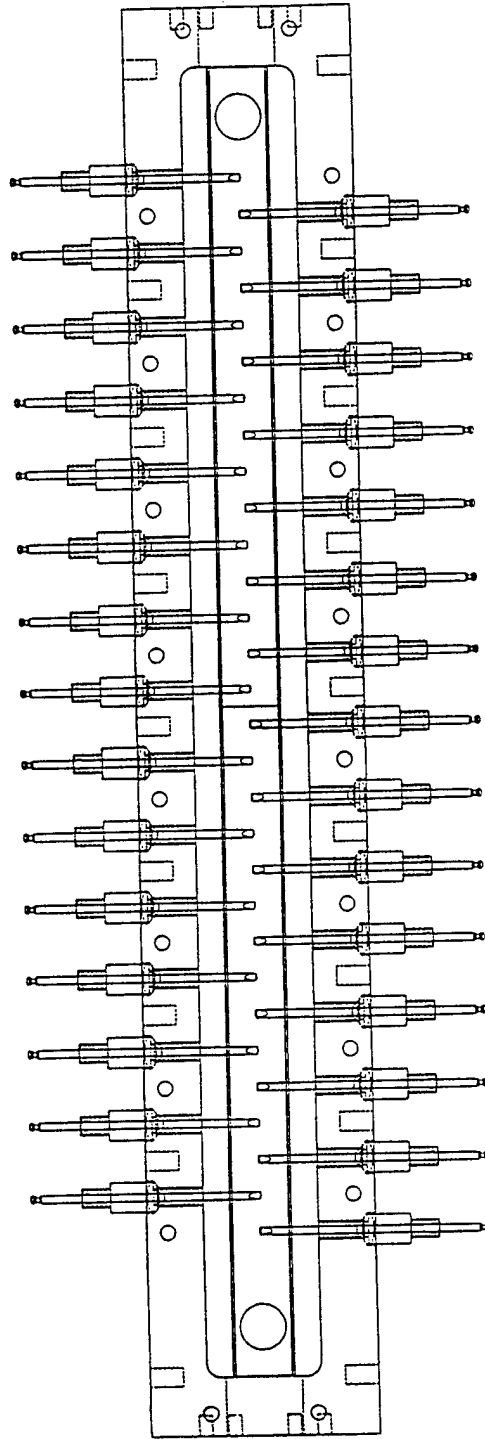
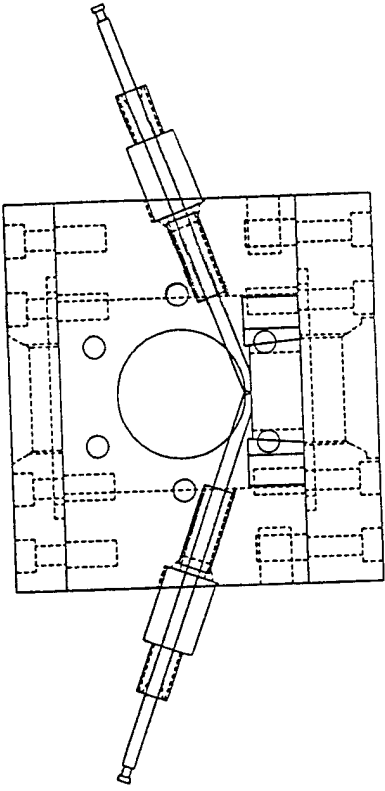

FIG. 11

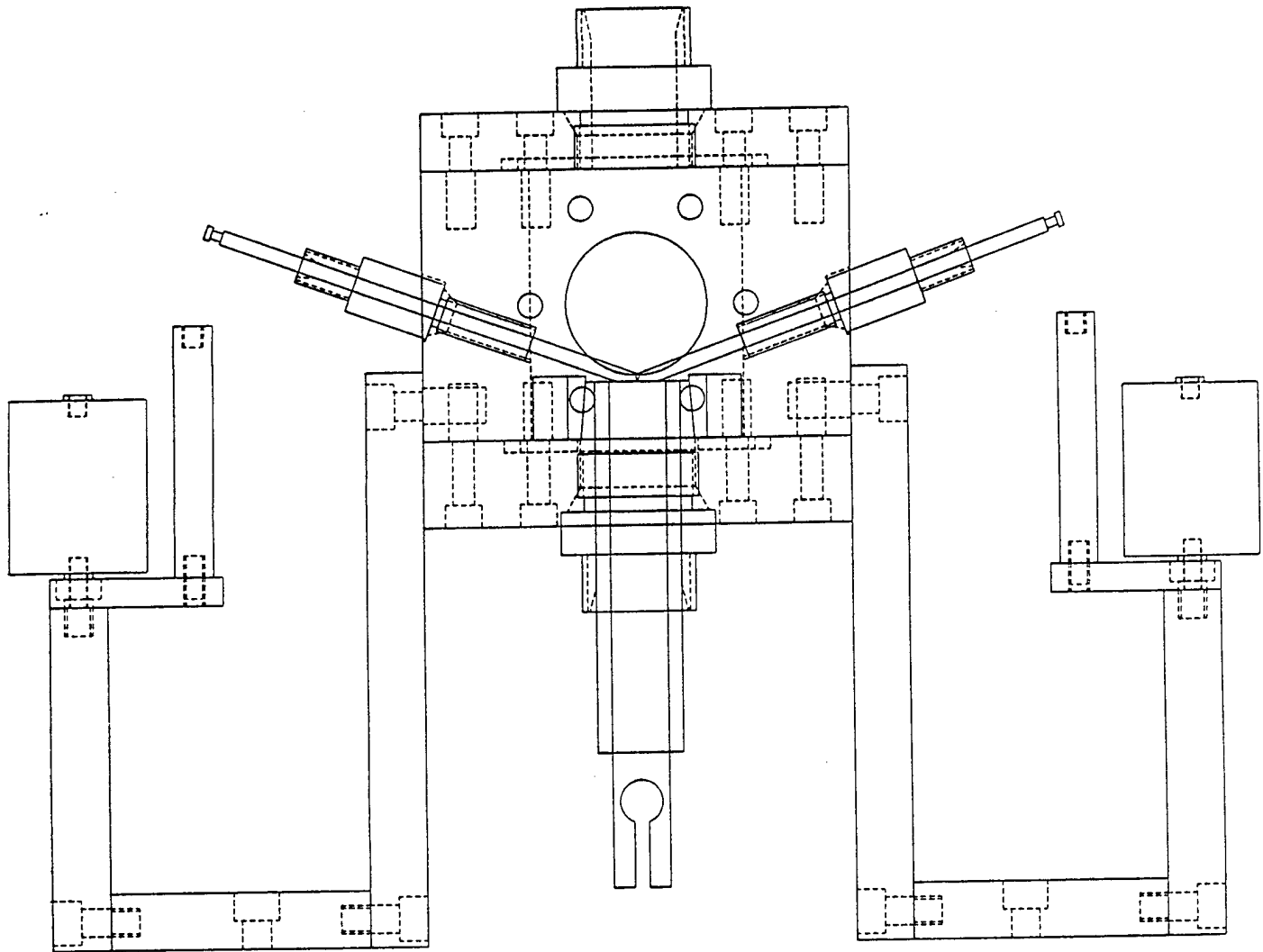

FIG. 12

With this new design, experiments were carried out on the atomic iodine laser (1.315  $\mu\text{m}$ ). For gas mixtures of typically 570 Torr Ar, 190 Torr  $\text{N}_2$ , 6 Torr  $\text{SF}_6$ , and 20 Torr  $\text{CF}_3\text{I}$ , output energies  $> 0.75$  J were obtained for cavity output couplings of only 10%. Higher output couplings were not investigated but the optimal value is expected to be 40-50%. The pulse energy is a weak function of the  $\text{C}_3\text{F}_7\text{I}$  partial pressure (cf. Figure 13) but optimal results were obtained between 15 and 20 Torr of the precursor. A detailed summary of the results that were obtained for both XeF and iodine is given in a paper that was published in *Optics Letters*. A copy of the article can be found in the Appendix.

For this technology to be practical for DOD applications, it is essential that the system be robust and the surface dielectric long-lived. For that reason, lifetime studies of the dielectric were carried out with emphasis on the erosion rate of the surface. Figures 14 and 15 are microstyles profiles of the channel produced in a glass ceramic (Macor) dielectric. After several tens of shots (Figure 14), a channel  $\sim 12$   $\mu\text{m}$  in depth has been produced in the dielectric, which corresponds to an erosion rate of  $\sim 0.3$   $\mu\text{m} - \text{shot}^{-1}$ . With additional shots, however, the erosion rate appears to decline quickly. Figure 15 shows the channel as it exists after several *hundred* shots. The erosion rate has now dropped below 0.1  $\mu\text{m}/\text{shot}$  and it is expected that the use of  $\text{Al}_2\text{O}_3$  or SiC - coated dielectric surfaces will yield erosion rates more than an order-of-magnitude smaller than those observed with the glass ceramic. Macor contains 46%  $\text{SiO}_2$  and 7%  $\text{B}_2\text{O}_3$  by weight and is more a glass than a ceramic. Consequently, materials that are more refractory in nature will undoubtedly be more resistant to erosion and it is likely that dielectric lifetimes exceeding  $10^5$  shots can be achieved.

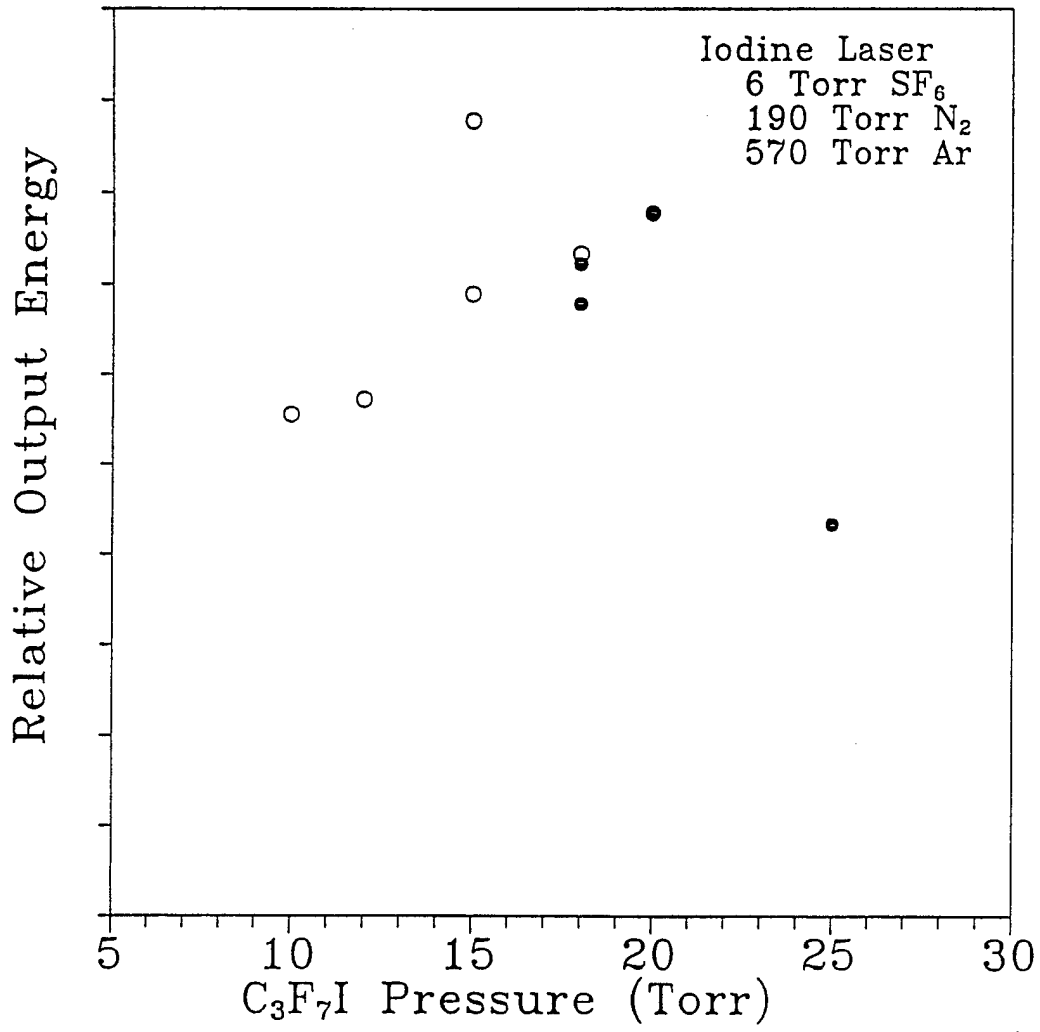
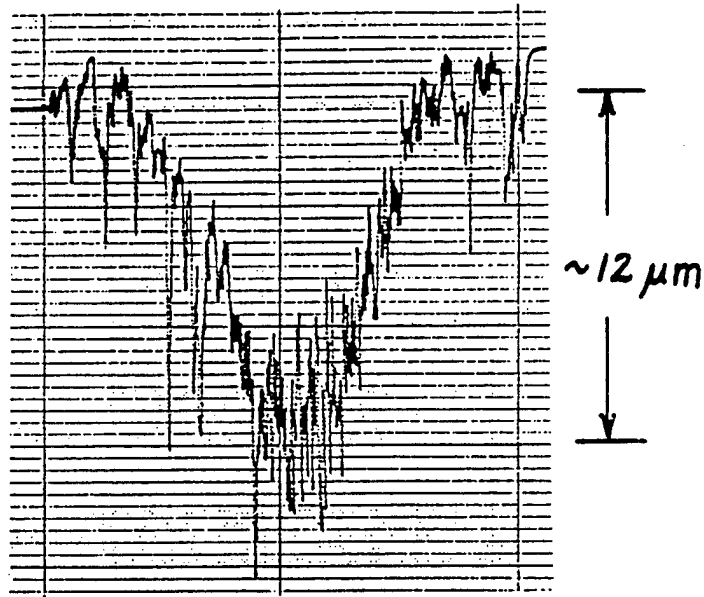

FIG. 13

## EROSION OF DIELECTRIC



Erosion Rate:  $6 \cdot 10^{-2} - 0.3 \mu\text{m} - \text{shot}^{-1}$ , dictated primarily by composition of ceramic.

$\text{Al}_2\text{O}_3$  and SiC-coated surfaces expected to exhibit erosion rates more than an order of magnitude smaller which are required for acceptable lifetimes ( $> 10^5$  shots).

FIG. 14

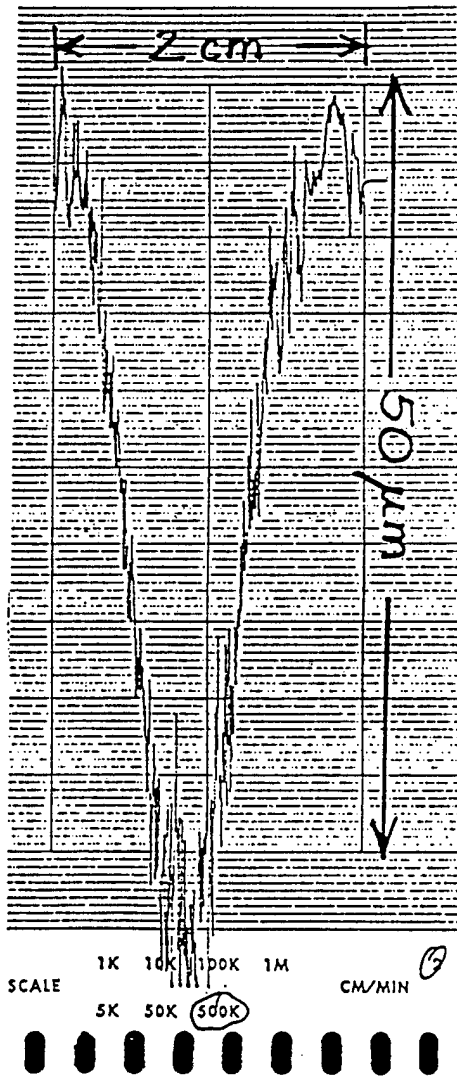

FIG. 15

## SUMMARY

A compact surface discharge system has been designed, constructed and applied to the blue-green C→A band of XeF and the 1.315  $\mu\text{m}$  transition of atomic iodine. This system has a "footprint" of  $1\text{m}^2$  and yet more than  $10\text{ MW} \cdot \text{cm}^{-1}$  is dissipated by the discharge. The impedance of the generator is well-matched to the discharge and dielectric erosion rates  $< 0.1\ \mu\text{m} \cdot \text{shot}^{-1}$  have been measured. Pulse energies exceeding 53 mJ have been obtained on the C→A band of XeF with  $< 2\%$  of output coupling and  $> 0.75\text{ J}$  at 1.315  $\mu\text{m}$  was recorded for the atomic iodine laser when the output coupling was 10%.

## ACKNOWLEDGMENT

The support of the Office of Naval Research and the U.S. Air Force through the Phillips Laboratory (Kirtland AFB) is gratefully acknowledged.

APPENDIX: PUBLICATION REPRINT

# Compact XeF ( $C \rightarrow A$ ) and iodine laser optically pumped by a surface discharge

B. A. Knecht, R. D. Fraser,\* D. J. Wheeler, and C. J. Zietkiewicz†

Everitt Laboratory, Department of Electrical and Computer Engineering, University of Illinois, Urbana, Illinois 61801

L. D. Mikheev and V. S. Zuev

P. N. Lebedev Physical Institute, Moscow, Russian Federation

J. G. Eden

Everitt Laboratory, Department of Electrical and Computer Engineering, University of Illinois, Urbana, Illinois 61801

Received November 1, 1994

A compact surface-discharge laser system has been developed and applied to optically pumping the bound  $\rightarrow$  free XeF ( $C \rightarrow A$ ) transition that lases in the blue-green (475–490-nm) and the  $^2P_{1/2} \rightarrow ^2P_{3/2}$  transition of atomic iodine at 1.315  $\mu\text{m}$ . Employing no high voltage or current switches and occupying only  $\sim 1 \text{ m}^2$  of table space, this device has an active length of  $\sim 50 \text{ cm}$  and at present dissipates  $> 8 \text{ MW/cm}$  of surface discharge for a stored energy of 2.5 kJ. With 5% output coupling at 485 nm, energies of  $> 50 \text{ mJ}$  are obtained on the XeF ( $C \rightarrow A$ ) transition in 1.5- $\mu\text{s}$  (FWHM) pulses. The spectrum of the untuned oscillator is virtually free of absorption features and has a width of  $\sim 15 \text{ nm}$  (FWHM). Pulse energies exceeding 0.7 J have been obtained for iodine at 1.3  $\mu\text{m}$  with an output coupling of only 10%.

Few visible amplifiers offer the bandwidth (70–80 nm) and high saturation intensity afforded by the XeF ( $C \rightarrow A$ ) transition. Consequently, as described by Sharp *et al.*<sup>1</sup> and Mikheev,<sup>2</sup> this system has attractive implications for spectroscopy because the medium will support the amplification of blue-green pulses having temporal widths as short as  $\sim 5$ –10 fs. Despite the tunability and homogeneously broadened gain profile of the  $C \rightarrow A$  laser, however, several of its characteristics, including the time required to reach threshold and the production of atomic and molecular absorbers, have typically constrained the output pulse energies of  $C \rightarrow A$  lasers driven by electron impact excitation (transverse discharge or electron-beam pumping) to well below 1 J.<sup>3–6</sup>

Lasing on the  $B \rightarrow X$  band of XeF by photodissociating XeF<sub>2</sub> was demonstrated independently by two groups employing either an exploding wire<sup>7</sup> or electron-beam-excited Xe<sub>2</sub> (Ref. 8) as the optical source. Shortly thereafter, groups at the Lebedev Physical Institute in Moscow and the Stanford Research Institute reported<sup>9,10</sup> oscillation on the  $C \rightarrow A$  transition with optical pumping. Basov *et al.*<sup>9</sup> obtained single-pulse energies as large as 14.5 J with exploding wire excitation and, by photodissociating XeF<sub>2</sub> with incoherent radiation from the Xe dimer, Bischel *et al.*<sup>10</sup> also demonstrated lasing and were successful in tuning the oscillator more than 50 nm ( $\sim 460$ –510 nm). In both cases, the laser spectrum exhibited only a few atomic absorption features because the pumping mechanism for the upper laser level is selective and efficient; consequently few extraneous species (potential absorbers) are produced.

In 1984 Kashnikov *et al.*<sup>11</sup> demonstrated the optical excitation of this laser with a multisection, surface-discharge emitting broadband radiation having an effective temperature of  $\sim 3 \times 10^4 \text{ K}$ . The attractive

aspects of the pumping scheme include the feasibility of repetitive pulsing and its simplicity. Subsequent scaling of this approach in length and energy dissipated by the plasma has yielded output energies as high as 130 J in pulses of 1–3- $\mu\text{s}$  (FWHM) duration.<sup>11,12</sup> Whereas surface discharge pumping has demonstrated the potential of producing pulse energies of tens of joules with overall efficiencies approaching 1%, previous devices were large and limited to essentially single-shot operation.

This Letter describes the design and performance of a relatively compact surface-discharge system that has been applied to pumping the XeF ( $C \rightarrow A$ ) and iodine atomic lasers. This device, which has a gain length of 50 cm and employs no high-voltage or current switches, is rugged and reliable and has produced single-pulse energies exceeding 50 mJ on the  $C \rightarrow A$  transition and  $> 0.7 \text{ J}$  at 1.315  $\mu\text{m}$ .

A schematic diagram of the system's electrical design, which permits reproducible and uniform discharges extending over tens of centimeters to be generated with a single, moderate power supply voltage (30 kV in this case), is given at the top of Fig. 1. The central feature of this design is the installation of capacitively and resistively ballasted molybdenum pins in the surface dielectric, which serve the dual purpose of establishing and spatially confining the discharge. All of the gaps between pins in the array, *except that for the first pair*, are set such that breakdown between adjacent pins occurs at 30 kV. Once the full supply voltage is impressed across the entire channel (left-hand electrode to ground), the first gap in the linear array is ignited by driving the first pin negative by  $\sim 50 \text{ kV}$  with a pulse transformer. As current begins to flow in this gap, the voltage at pin 1 rises to the supply voltage and, because pin 2 is at ground potential, the second gap self-breaks. The

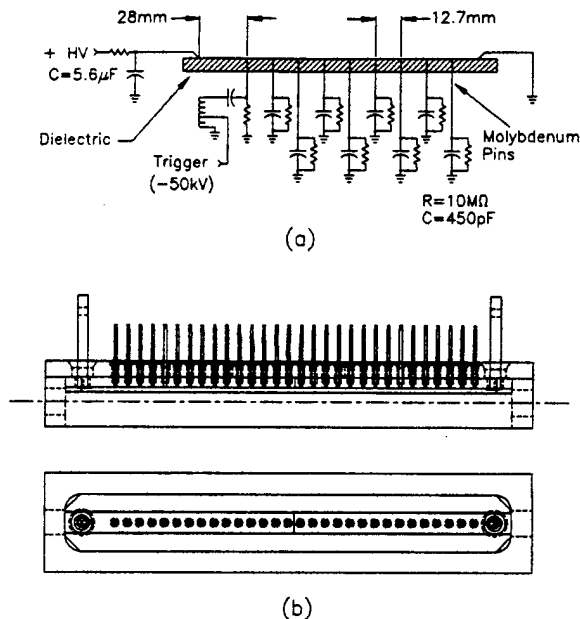

Fig. 1. (a) Schematic diagram of the circuitry responsible for triggering the discharge and ballasting the pins. The active length of the present device is  $\sim 50$  cm, and the charging voltage is 30 kV; (b) side and end-on views of the laser chamber and pin array showing the dielectric and high-voltage and ground feedthroughs.

remaining gaps follow in succession, and a discharge across the entire length of the device is established. At this point the bulk of the energy stored in capacitor  $C$  is delivered to the plasma, which heats rapidly and emits an intense blackbody spectrum [ $T \sim (2-3) \times 10^4$  K]. Note that, once the discharge is established, virtually no current flows through the ballast resistors, and the  $RC$  pairs are effectively isolated electrically from the plasma. Both end-on and side views of the laser chamber, dielectric, and pin array are illustrated in Fig. 1(b).

This approach has several advantages over previous designs. It appears that discharges can be established over arbitrarily long path lengths without the need to switch each section independently. In fact, no high-current or -voltage switches are employed at all, which lowers the system's equivalent series inductance and eliminates the substantial energies that are frequently consumed by switches in low-impedance circuits of this type.

The present device comprises a  $5.6\text{-}\mu\text{F}$  bank of low-inductance ( $\approx 50$  nH) capacitors and a laser head that together occupy  $\sim 1$  m<sup>2</sup> of table space. Considerable effort was devoted to minimizing the inductance of the system, and current waveforms obtained with a modified Rogowski coil show that the impedance of the power generator is well matched to that of the plasma. Specifically,  $>80\%$  of the 2.5 kJ stored in the capacitor bank (at 30-kV charging voltage) is dissipated by the surface discharge in the first half-cycle of the current. For a power pulse having a FWHM of  $5\ \mu\text{s}$ , this corresponds to a power deposition per unit length ( $P_d$ ) in the plasma of  $\sim 10$  MW cm<sup>-1</sup>. In most of the experiments carried out to date, a glass ceramic has served as the surface dielectric. Erosion

of this material has been measured with a microstylus (Dektak) to be  $<0.3\ \mu\text{m}$  shot<sup>-1</sup>.

Lasing has been obtained on both the  $B \rightarrow X$  and  $C \rightarrow A$  transitions of XeF, but the results for the blue-green band will be emphasized here. Initial experiments were carried out with a 600-Torr Ar/190-Torr N<sub>2</sub>/6-Torr SF<sub>6</sub>/ $\sim 1.5$ -Torr XeF<sub>2</sub> mixture in which the SF<sub>6</sub> component served to remove low-energy electrons from the active medium by dissociative attachment. Measurements of the small-signal gain coefficient ( $\gamma_0$ ) at 488 nm with a cw Ar<sup>+</sup> laser show  $\gamma_0$  to be  $0.3\%$  cm<sup>-1</sup>, which is virtually identical to the values that have been reported for much larger surface-discharge devices (up to  $\sim 42$ -MW cm<sup>-1</sup> dissipated power and 1.7-m active length).<sup>11,12</sup>

When an optical cavity, consisting of two dielectric mirrors separated by 100 cm, was installed around the active medium, lasing was observed across a broad region in the blue-green ( $\sim 470$ – $495$  nm). One mirror was a high reflector with a radius of curvature of 5 m and a reflectivity  $>99.9\%$  at 480 nm, while the output coupler was flat and had a transmission of 2% or 5% at 485 nm. Both were overcoated with Al<sub>2</sub>O<sub>3</sub>, allowing them to be in direct contact with the active medium, and were antireflection coated for 351 nm.

Figure 2 shows the laser spectrum that was recorded with a 0.25-m spectrograph (in second order) and a diode array. Note that the spectral band-width of the laser is  $\sim 15$  nm ( $\sim 640$  cm<sup>-1</sup>) and the few absorption features present are assigned as  $7p[5/2, 3/2, 1/2], 6p'[3/2] - 6s[3/2]_1$  (<sup>3</sup>P<sub>1</sub>) transitions of atomic Xe. The variation of laser pulse energy with the partial pressure of XeF<sub>2</sub> is illustrated in Fig. 3 for a cavity output coupling of 5% and 2.5 kJ of energy stored in the capacitors. In taking these data, the Ar, N<sub>2</sub>, and SF<sub>6</sub> partial pressures were held constant at 600, 190, and 6 Torr, respectively. Energies as large as 53 mJ in  $\sim 1.5\text{-}\mu\text{s}$  (FWHM) pulses have been obtained to date for XeF<sub>2</sub> number densities of  $\sim 5.5 \times 10^{16}$  cm<sup>-3</sup> (1.7 Torr at 300 K). Currently the output pulse energies are limited by (1) the cavity coupling (5%) [the optimal value is expected to be 30–40% (Ref. 12)], (2)  $P_d$  [the available data for surface discharge pumping suggest that

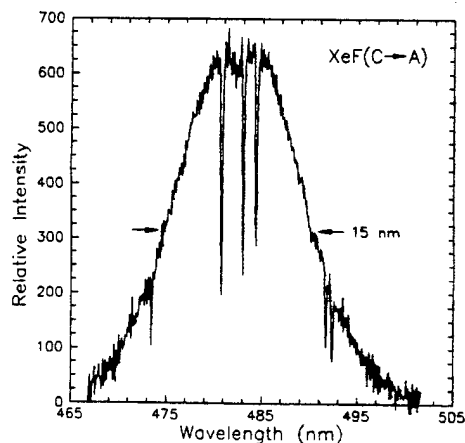

Fig. 2. XeF ( $C \rightarrow A$ ) laser spectrum produced by photodissociation of XeF<sub>2</sub> in a 600-Torr Ar/190-Torr N<sub>2</sub>/6-Torr SF<sub>6</sub>/ $\sim 1.5$ -Torr XeF<sub>2</sub> gas mixture with the surface discharge (2.5 kJ of stored energy).

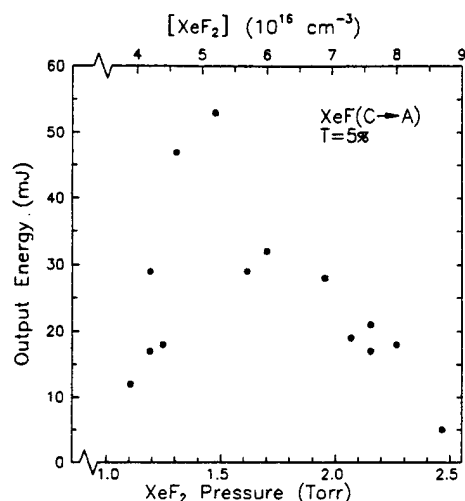

Fig. 3. Dependence of  $C \rightarrow A$  laser output pulse energy on the  $\text{XeF}_2$  partial pressure for a 600-Torr Ar/190-Torr  $\text{N}_2$ /6-Torr  $\text{SF}_6$  gas mixture at 300 K.

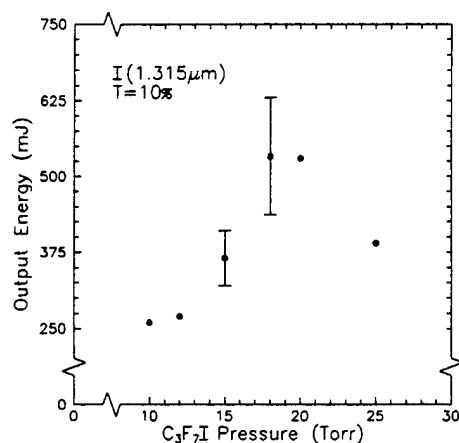

Fig. 4. Variation of iodine laser single-pulse energies with the  $\text{C}_3\text{F}_7\text{I}$  partial pressure for a 600-Torr Ar/190-Torr  $\text{N}_2$ /6-Torr  $\text{SF}_6$  gas mixture. The cavity output coupling was held at 10% for all data shown. The highest single-pulse energy observed was  $>700$  mJ, and the error bars given for two points represent  $\pm 1\sigma$  in the observed pulse energy, reflecting pulse-to-pulse fluctuations that appear to derive largely from nonuniform mixing of the gas mixture.

overall efficiency rises rapidly for  $P_d \geq 30 \text{ MW cm}^{-1}$  (Ref. 13)], and (3) the single-channel design of the current device. Consequently, it is expected that, with increased cavity output coupling and energy storage (as much as 6 kJ is available with the existing system), pulse energies of several hundred millijoules should be obtainable from this device. Finally, the laser pulse width is determined by the velocity of the pump bleaching wave, which has been measured to be  $\sim 3 \text{ cm } \mu\text{s}^{-1}$ . Since the gain region has a thickness of 1–3 cm  $\{(\sigma \times [\text{XeF}_2])^{-1}$ , where  $\sigma = 9 \times 10^{-18} \text{ cm}^2$  and moves away from the surface with the bleaching wave, amplification of sub-100-fs pulses with such a system would likely involve multipass extraction in the plane parallel to the surface dielectric.<sup>2</sup>

Similar studies were carried out for the atomic-iodine laser at  $1.315 \mu\text{m}$  by photodissociating  $\text{C}_3\text{F}_7\text{I}$

in a mixture of Ar,  $\text{C}_3\text{F}_7\text{I}$ , and  $\text{SF}_6$ . Figure 4 summarizes the results of measurements of the single-pulse energy produced by the laser when the  $\text{C}_3\text{F}_7\text{I}$  partial pressure is increased to 25 Torr. A maximum in the instantaneous output power was observed for a partial pressure of 18–20 Torr, and the highest single-pulse energy observed in these experiments was  $>700$  mJ. All of these measurements were made for output couplings of 10%, and yet estimates suggest that the optimal value is in the vicinity of 30%.

In summary, a compact surface-discharge system has successfully pumped XeF ( $C \rightarrow A$ ) and I ( $1.3\text{-}\mu\text{m}$ ) lasers, and the results demonstrate that this device is suitable as an amplifier for the generation of energetic ( $>100$  mJ), femtosecond pulses in the blue-green.

Several suggestions from G. N. Kashnikov and S. B. Mamaev and the engineering assistance of K. K. King, C. A. Henderson, and S. A. McDonald are greatly appreciated. This research was supported by the U.S. Air Force Phillips Laboratory (D. Stone) and the Office of Naval Research (V. Smiley).

\*Present address, Cynosure, Inc., 35 Wiggins Avenue, Bedford, Massachusetts 01730.

†Present address, Helios, Inc., 1822 Sunset Place, Longmont, Colorado 80501.

## References

1. T. E. Sharp, Th. Hofmann, C. B. Dane, W. L. Wilson, Jr., F. K. Tittel, and P. J. Wisoff, *Opt. Lett.* **15**, 1461 (1990).
2. L. D. Mikheev, preprint 125 (P. N. Lebedev Physical Institute, Moscow, 1991).
3. C. H. Fisher, R. E. Center, G. J. Mullaney, and J. P. McDaniel, *Appl. Phys. Lett.* **35**, 26 (1979).
4. R. Burnham, *Appl. Phys. Lett.* **35**, 48 (1979).
5. W. E. Ernst and F. K. Tittel, *Appl. Phys. Lett.* **35**, 36 (1979).
6. G. J. Hirst, C. B. Dane, W. L. Wilson, R. Sauerbrey, F. K. Tittel, and W. L. Nighan, *Appl. Phys. Lett.* **54**, 1851 (1989), and references therein.
7. N. G. Basov, V. S. Zuev, L. D. Mikheev, D. B. Stavrovskii, and V. I. Yalovoi, *Sov. J. Quantum Electron.* **7**, 1401 (1977) [*Kvantovaya Elektron. (Moscow)* **4**, 2453 (1977)].
8. J. G. Eden, *Opt. Lett.* **3**, 94 (1978).
9. N. G. Basov, V. S. Zuev, A. V. Kanaev, L. D. Mikheev, and D. B. Stavrovskii, *Sov. J. Quantum Electron.* **9**, 629 (1979) [*Kvantovaya Elektron. (Moscow)* **6**, 1074 (1979)].
10. W. K. Bischel, H. H. Nakano, D. J. Eckstrom, R. M. Hill, D. L. Huestis, and D. C. Lorents, *Appl. Phys. Lett.* **34**, 565 (1979); W. K. Bischel, D. J. Eckstrom, H. C. Walker, Jr., and R. A. Tilton, *J. Appl. Phys.* **52**, 4429 (1981).
11. G. N. Kashnikov, N. P. Kozlov, V. A. Platonov, V. A. Reznikov, and V. A. Sorokin, *Sov. J. Quantum Electron.* **14**, 1422 (1984) [*Kvantovaya Elektron. (Moscow)* **11**, 2129 (1984)].
12. V. S. Zuev, G. N. Kashnikov, and S. B. Mamaev, *Sov. J. Quantum Electron.* **22**, 973 (1992) [*Kvantovaya Elektron. (Moscow)* **19**, 1047 (1992)].
13. B. A. Knecht, R. D. Fraser, D. J. Wheeler, C. J. Zietkiewicz, L. D. Mikheev, V. S. Zuev, and J. G. Eden, *Proc. Soc. Photo-Opt. Instrum. Eng.* **2118**, 59 (1994).