

NSWCCD-SIG-97/038-7030 Loss Factors of a Complex Composed of a Number of Coupled Harmonic Oscillators

Carderock Division
Naval Surface Warfare Center

9500 MacArthur Blvd.
West Bethesda, Maryland 20817-5700

NSWCCD-SIG-97/038-7030 February 1997
Signatures Directorate
Research and Development Report

**Loss Factors of a Complex Composed of a
Number of Coupled Harmonic Oscillators**

by

G. Maidanik

19970521 071



Approved for public release; Distribution is unlimited.

DTIC QUALITY INSPECTED 1

REPORT DOCUMENTATION PAGE

Form Approved
OMB No. 0704-0188

1a. REPORT SECURITY CLASSIFICATION

Unclassified

1b. RESTRICTIVE MARKINGS

None

2a. SECURITY CLASSIFICATION AUTHORITY

3. DISTRIBUTION / AVAILABILITY OF REPORT

Approved for public release.

2b. DECLASSIFICATION/DOWNGRADING SCHEDULE

Distribution is unlimited.

4. PERFORMING ORGANIZATION REPORT NUMBER(S)

NSWCCD-SIG-97/038-7030

5. MONITORING ORGANIZATION REPORT NUMBER(S)

6a. NAME OF PERFORMING ORGANIZATION

NSWC, Carderock Division

6b. OFFICE SYMBOL
(If applicable)

Code 7030

7a. NAME OF MONITORING ORGANIZATION

6c. ADDRESS (City, State, and ZIP Code)

9500 MacArthur Blvd.
West Bethesda, MD 20817-5700

7b. ADDRESS (City, State, and ZIP Code)

8a. NAME OF FUNDING/SPONSORING
ORGANIZATION8b. OFFICE SYMBOL
(If applicable)

9. PROCUREMENT INSTRUMENT IDENTIFICATION NUMBER

8c. ADDRESS (City, State, and ZIP Code)

10. SOURCE OF FUNDING NUMBERS

PROGRAM
ELEMENT NO.PROJECT
NO.TASK
NO.WORK UNIT
ACCESSION NO.

11. TITLE (Include Security Classification)

Loss Factors of a Complex Composed of a Number of Coupled Harmonic Oscillators

12. PERSONAL AUTHOR(S)

G. Maidanik

13a. TYPE OF REPORT

Research & Development

13b. TIME COVERED

FROM 96-11-01 TO 97-2-28

14. DATE OF REPORT (Year, Month, Day)

1997 Feb 28

15. PAGE COUNT

44

16. SUPPLEMENTARY NOTATION

17. COSATI CODES

FIELD GROUP SUB-GROUP

18. SUBJECT TERMS (Continue on reverse if necessary and identify by block number)

Harmonic Oscillator

Structural Fuzzy

Loss Factor

Statistical Energy Analysis (SEA)

19. ABSTRACT (Continue on reverse if necessary and identify by block number)

Investigation of the response of a complex composed of a number of coupled harmonic oscillators is conducted. One of the harmonic oscillators is designated as the master, the others as satellites. The expression for the loss factor of the coupled master harmonic oscillator is sought. Two distinct loss factors are defined; the prevailing loss factor and the effective loss factor. The first is defined in terms of the real part of the inverse of the normalized insitu admittance of the master harmonic oscillator. The second is defined in terms of the ratio of the normalized input power into the master harmonic oscillator to the normalized stored energy in the complex due to that power injection. The relationship and the contrast between these two loss factors are revealed. It is argued that, with the exception of an isolated master harmonic oscillator, the prevailing loss factor is apparent; it is the effective loss factor that is real. Whereas the prevailing loss factor invokes the question: "Where did the energy go?," the effective loss factor renders this question moot.

Under certain approximations, expressions for the effective loss factor are derived, in this report, which are reminiscent of an expression that was recently derived for the effective loss factor of a structural fuzzy. The latter expression was derived via statistical energy analysis (SEA).

20. DISTRIBUTION / AVAILABILITY OF ABSTRACT

 UNCLASSIFIED/UNLIMITED SAME AS RPT. DTIC USERS

21. ABSTRACT SECURITY CLASSIFICATION

Unclassified

22a. NAME OF RESPONSIBLE INDIVIDUAL

Maidanik, G.

22b. TELEPHONE (Include Area Code)

(301)227-1292

22c. OFFICE SYMBOL

NSWCCD 7030

CONTENTS

	Page
ABSTRACT	1
1.0 INTRODUCTION.....	2
II. EQUATION OF MOTION OF A COMPLEX COMPOSED OF A NUMBER OF COUPLED HARMONIC OSCILLATORS.....	4
III. QUADRATIC FORMS OF THE EQUATION OF MOTION.....	8
IV. LOSS FACTORS:.....	10
A. OF AN ISOLATED MASTER HARMONIC OSCILLATOR.....	10
B. OF A MASTER HARMONIC OSCILLATOR WITH THE SATELLITE HARMONIC OSCILLATORS BLOCKED	13
V. DEFINITION OF THE PREVAILING AND EFFECTIVE LOSS FACTORS	17
VI. THE PREVAILING LOSS FACTOR FOR A COMPLEX IN WHICH THE SATELLITE HARMONIC OSCILLATORS ARE UNCOUPLED TO EACH OTHER.....	24
VII. THE EFFECTIVE LOSS FACTOR FOR A COMPLEX IN WHICH THE SATELLITE HARMONIC OSCILLATORS ARE UNCOUPLED TO EACH OTHER.....	32
REFERENCES.....	38

FIGURES

Fig. 1. A Complex Composed of a Number of Coupled Harmonic Oscillators.	37
--	----

ABSTRACT

Investigation of the response of a complex composed of a number of coupled harmonic oscillators is conducted. One of the harmonic oscillators is designated as the master, the others as satellites. The expression for the loss factor of the coupled master harmonic oscillator is sought. Two distinct loss factors are defined; the prevailing loss factor and the effective loss factor. The first is defined in terms of the real part of the inverse of the normalized insitu admittance of the master harmonic oscillator. The second is defined in terms of the ratio of the normalized input power into the master harmonic oscillator to the normalized stored energy in the complex due to that power injection. The relationship and the contrast between these two loss factors are revealed. It is argued that, with the exception of an isolated master harmonic oscillator, the prevailing loss factor is apparent; it is the effective loss factor that is real. Whereas the prevailing loss factor invokes the question: "Where did the energy go?," the effective loss factor renders this question moot.

Under certain approximations, expressions for the effective loss factor are derived, in this report, which are reminiscent of an expression that was recently derived for the effective loss factor of a structural fuzzy. The latter expression was derived via statistical energy analysis (SEA).

1.0 INTRODUCTION

A number of questions seem to arise regarding the simplest of interactions; those among **harmonic oscillators**. The significance of these questions lies in the fact that they bear directly on questions relating to the statistical energy analysis (SEA) and structural fuzzies. SEA and, to some extent, the structural fuzzies are based on analogous interactions [1-5]. In this report these interactions are investigated for their own sake; SEA and structural fuzzies are only obliquely involved. In particular, two **loss factors** are defined for a complex that is composed of a number of harmonic oscillators. In this complex, one of the harmonic oscillators is designated as the **master** and the others are designated as **satellites**. The loss factors pertain to the master harmonic oscillator which is the only one to be externally driven; the responses of the satellite harmonic oscillators result only from their direct and/or indirect couplings to the master harmonic oscillator. It is argued that a **prevailing** loss factor can be defined from the normalized insitu admittance of the master harmonic oscillator. This loss factor is an **apparent** loss factor in the sense that it often raises the eternal question as to where the energy went? In a real loss factor this question is moot. With this in mind, an **effective** loss factor is defined as the ratio of the normalized **input power** imparted into the master harmonic oscillator by the external drive to the normalized **stored energy** in the complex. This stored energy includes not only the stored energies in all the harmonic oscillators, but also the stored energies in all the couplings among these harmonic oscillators. Unlike the prevailing loss factor, this effective loss factor is a **real** loss factor, notwithstanding the obvious identity of the two loss factors for an isolated master harmonic oscillator at resonance.

In this report the theoretical background is established and a few questions are analytically posed and answered. In order to simplify the answers, the analytical generality is curtailed in that the satellite harmonic oscillators are allowed to be coupled only to the master harmonic oscillator, but not to each other. Moreover, mass and gyroscopic coupling parameters are also removed, at this stage, in order to further simplify the

analytical descriptions. A **cell** of satellite harmonic oscillators is defined and used to derive expressions for the prevailing and effective loss factors for a cell hosting either a single or multiple satellite harmonic oscillators. In the latter case primitive statistical averaging are performed to replace a summation by a single term. The expressions that are derived, thereby, for the effective loss factor are reminiscent of the expression that is derived via SEA for the effective loss factor of a structural fuzzy [6]. Detailed investigations, beyond the determinations of the prevailing and effective loss factors, as performed in this report, are deferred to companion reports that are under preparation.

II. EQUATION OF MOTION OF A COMPLEX COMPOSED OF A NUMBER OF COUPLED HARMONIC OSCILLATORS

The equation of motion may be stated in the matrix form

$$\begin{aligned} \underline{\underline{Z}}(\omega) \underline{\underline{V}}(\omega) &= \underline{\underline{P}}_e(\omega) ; & \underline{\underline{V}}(\omega) &= \{V_j(\omega)\} ; \\ \underline{\underline{P}}_e(\omega) &= \{P_{ej}(\omega)\} ; & \underline{\underline{Z}}(\omega) &= (Z_{ji}(\omega)) , \end{aligned} \quad (1a)$$

where $V_j(\omega)$ is the response and $P_{ej}(\omega)$ is the external drive that is applied to the (j)th harmonic oscillator and the element $Z_{ji}(\omega)$ in the **impedance matrix** describes the coupling between the (i)th and the (j)th harmonic oscillators; the self-impedance element $Z_{jj}(\omega)$ describes the insitu impedance of the (j)th harmonic oscillator and, finally, $\underline{\underline{Z}}(\omega)$ is a square matrix of rank (N), (N) being the number of harmonic oscillator in the complex [7]. A model of such a complex is sketched in Fig. 1 [1,8]. The elements in the impedance matrix can be explicitly stated in the form

$$\underline{\underline{Z}}(\omega) = \left(Z_{jj}(\omega) \delta_{ji} + Z_{ji}(\omega) (1 - \delta_{ji}) \right) ;$$

$$Z_{jj}(\omega) = \sum_{n=1}^N Z_{nj}^-(\omega) ; \quad Z_{nj}^-(\omega) = [i\omega M_{jn} + (i\omega)^{-1} K_{jn}] = Z_{jn}^-(\omega) ;$$

$$M_{jn} = M_{nj} ; \quad K_{jn} = K_{nj} ; \quad K_{jn} = K_{jn}^0 (1 + i\eta_{jn}) , \quad (2a)$$

$$Z_{ji}(\omega) = [Z_{ji}^+(\omega) - G_{ji}(\omega)] ; \quad Z_{ji}^+(\omega) = [(i\omega)M_{ji} - (i\omega)^{-1}K_{ji}] ;$$

$$G_{ji}(\omega) = -G_{ij}(\omega); \quad Z_{ji}^+(\omega) = Z_{ji}(\omega)|_{G(\omega)=0} = Z_{ij}^+(\omega) , \quad (2b)$$

and these elements are required to satisfy the conditions

$$\operatorname{Re} \{Z_{ji}^{\bar{+}}(\omega) + Z_{ij}^{\bar{+}}(\omega)\} \begin{cases} \leq 0 \\ \geq 0 \end{cases} ; \quad \operatorname{Im} \{Z_{ji}^{\bar{+}} - Z_{ij}^{\bar{+}}\} = 0 , \quad (2c)$$

where $\operatorname{Re} \{ \}$ and $\operatorname{Im} \{ \}$ are the real and imaginary parts of the enclosed quantities [1]. In Eq. (2), K_{jj} and M_{jj} describe the stiffness and the mass parameters of the (j)th harmonic oscillator, respectively, whereas K_{ji} , M_{ji} and $G_{ji}(\omega)$ describe, respectively, the stiffness, the mass and the gyroscopic coupling parameters that are associated with the coupling between the (i)th and the (j)th harmonic oscillators, and the equality sign in the first of Eq. (2c) implies that the coupling is a **conservative coupling** [1]. It is noted, in this connection, that in this report the dampings are attributed to the stiffness parameters and the degree of damping in a stiffness parameter is assessed in terms of an individual loss factor; (η_{jj}) for the (j)th harmonic oscillator and (η_{ji}) for the coupling between the (i)th and the (j)th harmonic oscillators. Before trying to interpret these individual loss factors, it is convenient to designate one of the harmonic oscillators as the master and the remaining harmonic oscillators in the complex are designated as satellites. [cf. Fig. 1.] In addition, it is convenient to place the master harmonic oscillator (1)st and then to normalize Eq. (1a) in the form

$$\begin{aligned} \bar{Z}(\omega) \bar{V}(\omega) &= \bar{P}_e(\omega) ; & \bar{V}(\omega) &= \{\bar{V}_j(\omega)\} ; \\ \bar{P}_e(\omega) &= \{\bar{P}_{ej}(\omega)\} ; & \bar{Z}(\omega) &= (\bar{Z}_{ji}(\omega)) , \end{aligned} \quad (1b)$$

where

$$\begin{aligned}\bar{V}_j(\omega) &= [V_j(\omega)/V_o] ; & \bar{P}_{ej}(\omega) &= [P_{ej}(\omega)/P_{e1}(\omega)] ; \\ V_o(\omega) &= [P_{e1}(\omega)/(\omega M_{11})] ; & \bar{Z}_{ji}(\omega) &= [Z_{ji}(\omega)/(\omega M_{11})] ,\end{aligned}\quad (3)$$

and, from Eq. (2), it follows that

$$\begin{aligned}\bar{Z}_{jj}(\omega) &= \sum_{n=1}^N \bar{Z}_{nj}^-(\omega) ; & \bar{Z}_{nj}^-(\omega) &= i[\bar{M}_{nj} - (\omega_{nj}/\omega)^2 (1+i\eta_{nj})] ; \\ \bar{M}_{nj} &= (M_{nj}/M_{11}) ; & \omega_{jn}^2 &= (K_{jn}^o/M_{11}) ,\end{aligned}\quad (4a)$$

$$\begin{aligned}\bar{Z}_{ji}(\omega) &= [\bar{Z}_{ji}^+(\omega) - \bar{G}_{ji}(\omega)] ; & \bar{G}_{ji}(\omega) &= -\bar{G}_{ij}(\omega) ; \\ \bar{Z}_{ji}^+(\omega) &= i[\bar{M}_{ji} + (\omega_{ji}/\omega)^2 (1+i\eta_{ji})] ; & \bar{M}_{ji} &= (M_{ji}/M_{11}) ; \\ \omega_{ji}^2 &= (K_{ji}^o/M_{11}) ; & \bar{G}_{ji}(\omega) &= [G_{ji}(\omega)/(\omega M_{11})] .\end{aligned}\quad (4b)$$

To introduce some versatility in the description of the mechanism of damping in the harmonic oscillators and the couplings, the individual loss factors (η_{jj}) and (η_{ji}) may be elaborated upon in the forms

$$\eta_{jj} \rightarrow \eta_{jj} + (\omega/\omega_{jj}) (\bar{M}_{jj})^{1/2} \eta_{jj}^o , \quad (5a)$$

$$\eta_{ji} \rightarrow \eta_{ji} + (\omega / \omega_{ji}) (\omega_{ij} / \omega_{11}) \eta_{ji}^0 . \quad (5b)$$

In computations that are performed in companion reports, either (η_{jj}) and (η_{ji}) are constants, independent of the frequency variable (ω) , and (η_{jj}^0) and (η_{ji}^0) are zeros or vice versa. In the first choice, the damping is attributable to a response that is displacement controlled; in the second, to a velocity controlled response.

Returning to Eq. (1b), it is recognized that this equation can be inverted in a straightforward manner to yield

$$\underline{\bar{V}}(\omega) = \underline{\bar{Y}}(\omega) \underline{\bar{P}}_e(\omega) ; \quad \underline{\bar{Y}}(\omega) = (\underline{\bar{Y}}_{ji}(\omega)) = [\underline{\bar{Z}}(\omega)]^{-1} , \quad (6)$$

where $\underline{\bar{Y}}(\omega)$ is the normalized **admittance matrix**. An investigative interest in Eq. (6) involves, in this report, the definition of two significant loss factors; one is dubbed a **prevailing** loss factor and the other an **effective** loss factor. These two loss factors are defined in conjunction in order to emphasize the relationship and contrast between them; the relationship and contrast are instructive. However, before embarking on these definitions, it may be appropriate to pause at this stage and consider a few quadratic forms based on the equation of motion as expressed either in Eq. (1b) or in Eq. (6).

III. QUADRATIC FORMS OF THE EQUATION OF MOTION

In the preceding section, the linear form of the equation of motion of a complex composed of a number of coupled harmonic oscillators is described. For the sake of completeness, a number of quadratic forms that stems directly from the linear equation of motion are formally explored. In this vein, Eq. (6) may be manipulated, for example, to yield the quadratic form

$$\underline{\bar{V}}(\omega) \underline{\bar{V}}^\dagger(\omega) = \underline{\bar{Y}}(\omega) [\underline{\bar{P}}_e(\omega) \underline{\bar{P}}_e^\dagger(\omega)] \underline{\bar{Y}}^\dagger(\omega) , \quad (7)$$

where the superscript (\dagger) indicates transposing and taking the complex conjugate of the resulting matrix and/or vector [7]. [In this connection the taking of the complex conjugate of a quantity is designated by the superscript (*).] A quadratic form, such as Eq. (7), becomes useful if statistical measures can be beneficially imposed on some of the quantities in the quadratized form. Thus, if the external drives are assumed to be uncorrelated, so that

$$\langle \underline{\bar{P}}_e(\omega) \underline{\bar{P}}_e^\dagger(\omega) \rangle = (\langle |\bar{P}_{ej}(\omega)|^2 \rangle \delta_{ji}) = \underline{I}_e(\omega) , \quad (8)$$

then Eq. (7) simplifies to read

$$\langle \underline{\bar{V}}(\omega) \underline{\bar{V}}^\dagger(\omega) \rangle = \underline{\bar{Y}}(\omega) \underline{I}_e(\omega) \underline{\bar{Y}}^\dagger(\omega) , \quad (9)$$

where the angular brackets indicate that the enclosed quantity is appropriately averaged and, significantly, $\underline{I}_e(\omega)$ is a diagonal matrix.

Similarly, the equation of conservation of energy in the complex may be derived by quadratizing Eq. (1b) in the form

$$[\underline{\bar{Z}}(\omega) \underline{\bar{V}}(\omega)]^* \bullet \underline{\bar{V}}(\omega) = \underline{\bar{P}}_e^*(\omega) \bullet \underline{\bar{V}}(\omega) , \quad (10)$$

and only the real part is retained, on both sides of Eq. (10).

IV. LOSS FACTORS:

A. OF AN ISOLATED MASTER HARMONIC OSCILLATOR

Although a loss factor is often used to prescribe a degree of damping, there are several ways to define it. Unfortunately not all are either consistent or simply related to each other. Thus, in Eqs. (2) and (5), the individual loss factors (η_{jj}) and (η_{ji}) are defined to be associated with the stiffness parameters of the individual harmonic oscillators and the couplings among them. Although this definition is commonly used, it is seldom scrutinized. This scrutiny is not pursued in this report either; these individual **stiffness controlled** loss factors, in Eqs. (2) and (5), are accepted, as such, apriori. It stands to reason that these loss factors govern the loss factors that are associated with the complex as a whole.

To set the stage, the loss factors that relate to the isolated master harmonic oscillator are defined first. For this case, Eq. (6) yields

$$\bar{V}_1^o(\omega) = \bar{Y}_{11}^o(\omega) \bar{P}_{e1}(\omega) ;$$

$$[\bar{Y}_{11}^o(\omega)]^{-1} \bar{V}_1^o(\omega) = \bar{P}_{e1}(\omega) = 1 , \quad (11a)$$

where the superscript (o) indicates a reference to a master harmonic oscillator in isolation.

A **prevailing** loss factor $\eta_{p1}^o(\omega)$ may be defined, using Eq. (11a), in the form

$$\eta_{p1}^o(\omega) = \text{Re} \{ [\bar{Y}_{11}^o(\omega)]^{-1} \} ; \quad \eta_{p1}^o(\omega) = \eta_{11}(\omega_{11} / \omega)^2 . \quad (12a)$$

In this definition, the resistance controlled part in the normalized impedance, that is derived by inverting the normalized admittance $\bar{Y}_{11}^o(\omega)$ of the isolated master harmonic oscillator, is depicted as the loss factor. The prevailing loss factor $\eta_{p1}^o(\omega)$ may be alternately

defined. In this alternate definition, the normalized external input power $\bar{\pi}_{e1}^o(\omega)$ that is imparted to the isolated master harmonic oscillator needs to be estimated. This estimate is

$$\begin{aligned}\bar{\pi}_{e1}^o(\omega) &= \text{Re} \{ [\bar{V}_1^o(\omega)]^* \bar{P}_{e1}(\omega) \} \\ &= |\bar{V}_1^o(\omega)|^2 \text{Re} \{ [\bar{Y}_{11}^o(\omega)]^{-1} \},\end{aligned}\quad (13a)$$

where the superscript (*) designates the complex conjugate of the bracketed quantity. [cf. Eq. (7).] The normalized **kinetic** energy $\bar{\varepsilon}_{k1}^o(\omega)$ that is **stored** in the isolated master harmonic oscillator is similarly estimated as

$$\bar{\varepsilon}_{k1}^o(\omega) = (1/2) |\bar{V}_1^o(\omega)|^2. \quad (14a)$$

The prevailing loss factor $\eta_{p1}^o(\omega)$, as defined in Eq. (12a), may be correspondingly defined from Eqs. (13a) and (14a). In this definition

$$\eta_{p1}^o(\omega) = [\bar{\pi}_{e1}^o(\omega) / 2\bar{\varepsilon}_{k1}^o(\omega)] = \text{Re} \{ [\bar{Y}_{11}^o(\omega)]^{-1} \}, \quad (15a)$$

and, therefore, it emerges that the prevailing loss factor $\eta_{p1}^o(\omega)$ stated in Eq. (12a) is equivalent to that stated in Eq. (15a). [The normalization of the input power and stored energy are effected in this report by $\pi_o(\omega)$ and $\varepsilon_o(\omega)$, respectively, where $\pi_o(\omega) = \omega \varepsilon_o(\omega)$ and $\varepsilon_o(\omega) = M_{11} |V_o(\omega)|^2$, M_{11} is the mass of the master harmonic oscillator and $V_o(\omega)$ is defined in Eq. (3).] If the factor (2), in the $2\bar{\varepsilon}_{k1}^o(\omega)$, is meant to account for the normalized **potential** energy $\bar{\varepsilon}_{p1}^o(\omega)$ that is **stored** in the isolated master harmonic oscillator, then one may claim that Eq. (15a) is a proper attempt to define a **real** loss factor. With that in mind, a loss factor $\eta_{b1}^o(\omega)$ of a **sort** may be defined in the form

$$\eta_{b1}^o(\omega) = [\pi_{e1}^o(\omega) / \bar{\epsilon}_{e1}^o(\omega)] ;$$

$$\bar{\epsilon}_1^o(\omega) = (1/2) |\bar{V}_1^o(\omega)|^2 [1 + (\omega_{11}/\omega)^2] , \quad (16a)$$

where $\bar{\epsilon}_1^o(\omega)$ is the normalized **stored energy** in the isolated master harmonic oscillator in response to the normalized external input power $\bar{\pi}_{e1}^o(\omega)$. Since the normalized stored energy $\bar{\epsilon}_1^o(\omega)$ is also the normalized total stored energy $\bar{\epsilon}_{t1}^o(\omega)$ in the complex, which in this case is merely composed of the isolated master harmonic oscillator, the effective loss factor $\eta_{e1}^o(\omega)$ for the isolated master harmonic oscillator equates with the loss factor $\eta_{b1}^o(\omega)$ of a sort just defined in Eq. (16a). This effective loss factor is defined

$$\eta_{e1}^o(\omega) = [\pi_{e1}^o(\omega) / \bar{\epsilon}_{t1}^o(\omega)] ; \quad \bar{\epsilon}_{t1}^o = \bar{\epsilon}_1^o(\omega) ;$$

$$\eta_{e1}^o(\omega) = \eta_{b1}^o(\omega) = 2\eta_{p1}^o(\omega) [1 + (\omega_{11}/\omega)^2]^{-1} = 2\eta_{11}(\omega_{11}/\omega)^2 [1 + (\omega_{11}/\omega)^2]^{-1} ,$$

(17a)

where use is made of Eqs (12a) through (16a). It follows that there is a direct relationship between the effective loss factor $\eta_{e1}^o(\omega)$, the loss factor $\eta_{b1}^o(\omega)$ of a sort, the prevailing loss factor $\eta_{p1}^o(\omega)$ and, finally, the individual loss factor (η_{11}) of an isolated master harmonic oscillator. At, and in the vicinity of the resonance frequency (ω_{11}) of the master harmonic oscillator in isolation, Eqs. (12a) and (17a) show that all four loss factors are identical; namely

$$\eta_{e1}^o(\omega) \simeq \eta_{b1}^o(\omega) \simeq \eta_{p1}^o(\omega) \simeq \eta_{11} ; \quad (\omega_{11}/\omega)^2 \simeq 1 . \quad (18a)$$

Since, in general, only in the vicinity of the resonance frequency does a loss factor assume an appropriate significance, Eq. (18a) states that for a master harmonic oscillator in isolation, the four loss factors are substantially identical. A consistency in the four definitions of the loss factor is thus established in the case of an isolated harmonic oscillator.

B. OF A MASTER HARMONIC OSCILLATOR WITH THE SATELLITE HARMONIC OSCILLATORS BLOCKED

For this case, Eq. (6) yields

$$\bar{V}_1^b(\omega) = \bar{Y}_{11}^b(\omega) \bar{P}_{e1}(\omega) ;$$

$$[\bar{Y}_{11}^b(\omega)]^{-1} \bar{V}_1^b(\omega) = \bar{P}_{e1}(\omega) = 1 , \quad (11b)$$

where the superscript (*b*) indicates a reference to a master harmonic oscillator with the satellite harmonic oscillators blocked. A **prevailing** loss factor $\eta_{p1}^b(\omega)$ may be defined, using Eq. (11b), in the form

$$\eta_{p1}^b(\omega) = \text{Re} \{ [\bar{Y}_{11}^b(\omega)]^{-1} \} ;$$

$$\eta_{p1}^b(\omega) = \eta_{11}(\omega_{11}/\omega)^2 + \sum_{j=2}^N \eta_{1j}(\omega_{1j}/\omega)^2 . \quad (12b)$$

In this definition, the resistance controlled part in the normalized impedance, that is derived by inverting the normalized admittance $\bar{Y}_{11}^b(\omega)$ of the master harmonic oscillator with the satellite harmonic oscillators blocked, is depicted as the loss factor. From Eqs. (12a) and

(12b) one concludes that $\eta_{p1}^o(\omega) \leq \eta_{p1}^b(\omega)$, where the equality holds for conservative couplings in which $\eta_{1j} = 0$. The prevailing loss factor $\eta_{p1}^b(\omega)$ may be alternately defined. In this alternate definition, the normalized external input power $\bar{\pi}_{e1}^b(\omega)$ that is imparted to the master harmonic oscillator with the satellite harmonic blocked needs to be estimated. This estimate is

$$\begin{aligned}\bar{\pi}_{e1}^b(\omega) &= \text{Re} \{ [\bar{V}_1^b(\omega)]^* \bar{P}_{e1}(\omega) \} \\ &= |\bar{V}_1^b(\omega)|^2 \text{Re} \{ [\bar{Y}_{11}^b(\omega)]^{-1} \},\end{aligned}\quad (13b)$$

where the superscript (*) designates the complex conjugate of the bracketed quantity. [cf. Eq. (7).] The normalized **kinetic** energy $\bar{\epsilon}_{k1}^b(\omega)$ that is **stored** in the master harmonic oscillator with the satellite harmonic oscillators blocked is similarly estimated as

$$\bar{\epsilon}_{k1}^b(\omega) = (1/2) |\bar{V}_1^b(\omega)|^2. \quad (14b)$$

The prevailing loss factor $\eta_{p1}^b(\omega)$, as defined in Eq. (12b), may be correspondingly defined from Eqs. (13b) and (14b). In this definition

$$\eta_{p1}^b(\omega) = [\bar{\pi}_{e1}^b(\omega) / 2\bar{\epsilon}_{k1}^b(\omega)] = \text{Re} \{ [\bar{Y}_{11}^b(\omega)]^{-1} \}, \quad (15b)$$

and, therefore, it emerges that the prevailing loss factor $\eta_{p1}^b(\omega)$ stated in Eq. (12b) is equivalent to that stated in Eq. (15b). [Again, the normalization of the input power and stored energy are effected in this report by $\pi_o(\omega)$ and $\epsilon_o(\omega)$, respectively, where $\pi_o(\omega) = \omega \epsilon_o(\omega)$ and $\epsilon_o(\omega) = M_{11} |V_o(\omega)|^2$, M_{11} is the mass of the master harmonic oscillator and $V_o(\omega)$ is defined in Eq. (3).] If the factor (2), in the $2\bar{\epsilon}_{k1}^b(\omega)$, is meant to account for the normalized **potential** energy $\bar{\epsilon}_{p1}^b(\omega)$ that is **stored** in the master

harmonic oscillator with the satellite harmonic oscillators blocked, then one may claim that Eq. (15b) is a proper attempt to define a **real** loss factor. With that in mind, a loss factor $\eta_{b1}^b(\omega)$ of a **sort** may be defined in the form

$$\eta_{b1}^b(\omega) = [\bar{\pi}_{e1}^b(\omega) / \bar{\epsilon}_1^b(\omega)] ; \quad \eta_{p1}^b(\omega) = 2\eta_{p1}^b(\omega) [1 + (\omega_{11} / \omega)^2]^{-1} ;$$

$$\bar{\epsilon}_1^b(\omega) = (1/2) |\bar{V}_1^b(\omega)|^2 [1 + (\omega_{11} / \omega)^2] , \quad (16b)$$

where $\bar{\epsilon}_1^b(\omega)$ is the normalized **stored energy** in the isolated master harmonic oscillator in response to the normalized external input power $\bar{\pi}_{e1}^b(\omega)$. To define the effective loss factor $\eta_{e1}^b(\omega)$ for a complex in which the satellite harmonic oscillators are blocked, the normalized total stored energy $\bar{\epsilon}_{t1}^b(\omega)$ of the complex needs to be estimated; one may conclude that $\bar{\epsilon}_{t1}^b(\omega)$ exceeds $\bar{\epsilon}_1^b(\omega)$ if energy can be stored in the couplings. This normalized stored energy, under the condition that the satellite harmonic oscillators are blocked, is designated $\bar{\epsilon}_{s1}^b(\omega)$. [1]. The effective loss factor $\eta_{e1}^b(\omega)$ is then defined

$$\eta_{e1}^b(\omega) = [\bar{\pi}_{e1}^b(\omega) / \bar{\epsilon}_{t1}^b(\omega)] ; \quad \eta_{e1}^b(\omega) = \eta_{b1}^b(\omega) [1 + \zeta^b(\omega)]^{-1} ;$$

$$\bar{\epsilon}_{t1}^b(\omega) = \bar{\epsilon}_1^b(\omega) + \bar{\epsilon}_{s1}^b(\omega) ; \quad \bar{\epsilon}_{s1}^b(\omega) = (|\bar{V}_1^b(\omega)|^2 / 2) \sum_{j=2}^N [\bar{M}_{1j} + (\omega_{1j} / \omega)^2] ;$$

$$\zeta^b(\omega) = [\bar{\epsilon}_{s1}^b(\omega) / \bar{\epsilon}_1^b(\omega)] > 0 , \quad (17b)$$

where use is made of Eq. (16b) and Eq. (12b) is noted.

From Eqs. (12b) through (17b) one may deduce that

$$\eta_{e1}^b(\omega) \leq \eta_{b1}^b(\omega) \approx \eta_{p1}^b(\omega) = [\eta_{11}(\omega_{11}/\omega)^2 + \sum_{j=2}^N \eta_{1j}(\omega_{1j}/\omega)^2] ;$$

$$(\omega_{11}/\omega_{o1})^2 + \sum_{j=2}^N (\omega_{1j}/\omega_{o1})^2 = 1 ; \quad \omega \equiv \omega_{o1} , \quad (18b)$$

where the resonance frequency (ω_{o1}) relates to that of the master harmonic oscillator with the satellite harmonic oscillators blocked; this master harmonic oscillator constitutes a complex in which the satellite harmonic oscillators are held rigid. Clearly, the relationships between the various loss factors in Eq. (18b) are not as simply consistent as are those stated in Eq. (18a). In particular, it is noted that the prevailing loss factor $\eta_{p1}^b(\omega)$, in the vicinity of the resonance frequency (ω_{o1}), exaggerates the effective loss factor $\eta_{e1}^b(\omega)$. The exaggeration stems from the fact that the prevailing loss factor $\eta_{p1}^b(\omega)$, by definition, fails to account for the total stored energy; the stored energy in the complex transcends that stored in the master harmonic oscillator. In the definition of the effective loss factor $\eta_{e1}^b(\omega)$ the deficiency in accounting for the stored energy is rectified; in this definition the total energy stored is properly accounted for.

V. DEFINITION OF THE PREVAILING AND EFFECTIVE LOSS FACTORS

The restriction that the master harmonic oscillator is either isolated or the satellite harmonic oscillators are blocked is now removed; the couplings among the harmonic oscillators that compose the complex are reinstated and the satellite harmonic oscillators are set free.

Using Eq. (6), the equation of motion for the master harmonic oscillator is

$$\bar{V}_1(\omega) = \bar{Y}_{11}(\omega) \bar{P}_{e1}(\omega) ; \quad [\bar{Y}_{11}(\omega)]^{-1} \bar{V}_1(\omega) = \bar{P}_{e1}(\omega) = 1 . \quad (19)$$

[cf. Eq. (11).] A prevailing loss factor $\eta_{p1}(\omega)$ may be defined, using Eq. (19), in the form

$$\eta_{p1}(\omega) = \text{Re} \{ [\bar{Y}_{11}(\omega)]^{-1} \} . \quad (20)$$

[cf. Eq. (12).] Again, in this definition the resistance controlled part in the normalized insitu impedance of the master harmonic oscillator is depicted as the loss factor. In this case too, an alternative definition for the prevailing loss factor $\eta_{p1}(\omega)$ may be proposed. For this purpose, the normalized external input power $\bar{\pi}_{e1}(\omega)$ that is imparted to the master harmonic oscillator needs to be estimated. This estimate is

$$\bar{\pi}_{e1}(\omega) = \text{Re} \{ [\bar{V}_1(\omega)]^* \bar{P}_{e1}(\omega) \} = |\bar{V}_1(\omega)|^2 \text{Re} \{ [\bar{Y}_{11}(\omega)]^{-1} \} . \quad (21)$$

[cf. Eq. (13).] The normalized kinetic energy $\bar{\epsilon}_{k1}(\omega)$ that is stored in the master harmonic oscillator is similarly estimated as

$$\bar{\epsilon}_{k1}(\omega) = (1/2) |\bar{V}_1(\omega)|^2 . \quad (22)$$

[cf. Eq. (14).] Employing Eqs. (21) and (22) the prevailing loss factor, as defined in Eq. (20), may be equivalently defined

$$\eta_{p1}(\omega) = [\bar{\pi}_{e1}(\omega)/2\bar{\epsilon}_{k1}(\omega)] = \text{Re} \{ [\bar{Y}_{11}(\omega)]^{-1} \} . \quad (23)$$

[cf. Eq. (15).] Again, if the factor (2), in the $2\bar{\epsilon}_{k1}(\omega)$, is intended to account for the normalized potential energy $\bar{\epsilon}_{p1}(\omega)$ that is stored in the master harmonic oscillator, then one may claim that Eq. (23) is an attempt to give credence to the prevailing loss factor.

With that in mind, a loss factor $\eta_{b1}(\omega)$ of a sort may be defined in the form

$$\eta_{b1}(\omega) = [\bar{\pi}_{e1}(\omega)/\bar{\epsilon}_1(\omega)] ; \quad \eta_{b1}(\omega) = \eta_{p1}(\omega) [2\bar{\epsilon}_{k1}(\omega)/\bar{\epsilon}_1(\omega)] ;$$

$$\bar{\epsilon}_1(\omega) = (1/2) |\bar{V}_1(\omega)|^2 [1 + (\omega_{11}/\omega)^2] , \quad (24)$$

where $\bar{\epsilon}_1(\omega)$ is the normalized stored energy in the master harmonic oscillator in response to the normalized external input power $\bar{\pi}_{e1}(\omega)$. [cf. Eq. (16).] As Eq. (24) states, the loss factor $\eta_{b1}(\omega)$ of a sort is closely related to the prevailing loss factor $\eta_{p1}(\omega)$, as defined in Eq. (23).

A question arises: Is either of the loss factors $\eta_{p1}(\omega)$ or $\eta_{b1}(\omega)$ the appropriate loss factor for the coupled master harmonic oscillator? The loss factors $\eta_{p1}(\omega)$ and $\eta_{b1}(\omega)$ are defined under the assumption that the external normalized input power $\bar{\pi}_{e1}(\omega)$ that is imparted to the master harmonic oscillator is fully dissipated in this harmonic oscillator. Clearly this is not the case when couplings are present. Although it is assumed that only the master harmonic oscillator is driven externally, the satellite harmonic oscillators, as well as the couplings, store energies by virtue of their direct and/or indirect couplings to the master harmonic oscillator. These stored energies contribute to local dissipations in these parts of the complex. The externally imparted normalized power $\bar{\pi}_{e1}$

is, therefore, only partially dissipated in the master harmonic oscillator, which is contrary to the statements made in Eqs. (23) and (24). In this sense the prevailing loss factor $\eta_{p1}(\omega)$ and the loss factor $\eta_{b1}(\omega)$ of a sort are apparent rather than real. A real loss factor of the master harmonic oscillator needs to account for the stored energies throughout the complex; it is the dissipation of the normalized input power $\bar{\pi}_{e1}(\omega)$ by the total normalized stored energy $\bar{\epsilon}_{t1}(\omega)$ that yields the effective loss factor of the complex. [cf. Eq. (17b).] Therefore, to define the effective loss factor, it becomes necessary to estimate the normalized energy $\bar{\epsilon}_{t1}(\omega)$ that is stored in the complex as a result of imparting the normalized external input power $\bar{\pi}_{e1}(\omega)$ into the master harmonic oscillator. Now that the couplings are present, $\bar{\epsilon}_{t1}(\omega)$ accounts not only for the normalized stored energy $\bar{\epsilon}_1(\omega)$ in the master harmonic oscillator, but also for the normalized stored energy $\bar{\epsilon}_{s1}(\omega)$ that resides in the couplings and in the satellite harmonic oscillators. To reflect the multiplicity of the stored energies, the estimate of the normalized stored energy in the complex is formally stated in the form

$$\begin{aligned}\bar{\epsilon}_{t1}(\omega) &= \bar{\epsilon}_1(\omega) + \bar{\epsilon}_{s1}(\omega); & \bar{\epsilon}_{t1}(\omega) &= |\bar{V}_1(\omega)|^2 \bar{\bar{\epsilon}}_{t1}(\omega); \\ \bar{\epsilon}_1(\omega) &= |\bar{V}_1(\omega)|^2 \bar{\bar{\epsilon}}_1(\omega); & \bar{\epsilon}_{s1}(\omega) &= |\bar{V}_1(\omega)|^2 \bar{\bar{\epsilon}}_{s1}(\omega); \\ \bar{\bar{\epsilon}}_{s1}(\omega) &= \sum_{j=2}^N \bar{\bar{\epsilon}}_j(\omega) + \sum_{j=1}^N \sum_{i=1}^N \bar{\bar{\epsilon}}_{ij}(\omega) (1 - \delta_{ij}),\end{aligned}\tag{25}$$

where $|\bar{V}_1(\omega)|^2 \bar{\bar{\epsilon}}_j(\omega)$ is the normalized stored energy in the (j)th harmonic oscillator and $|\bar{V}_1(\omega)|^2 \bar{\bar{\epsilon}}_{ij}(\omega) (1 - \delta_{ij})$ is the normalized stored energy residing in the coupling between the (j)th and the (i)th harmonic oscillators. It follows from Eq. (25) that the normalized stored energy $\bar{\epsilon}_{s1}(\omega)$ is that of the complex as a whole excepting the

normalized stored energy $\bar{\epsilon}_1(\omega)$ in the master harmonic oscillator. Using Eqs. (3), (4) and (6), the components in Eq. (25) may be more explicitly stated in the form

$$\bar{\epsilon}_j(\omega) = (1/2) |C_{1j}(\omega)|^2 [\bar{M}_{jj} + (\omega_{jj}/\omega)^2];$$

$$(\omega_{jj})^2 = (K_{jj}^o / M_{11}); \quad \bar{M}_{jj} = (M_{jj} / M_{11}), \quad (26a)$$

$$\bar{\epsilon}_{ij}(\omega) = (1/2) |C_{1i}(\omega)|^2$$

$$[\bar{M}_{ij} |1 + |C_{ij}(\omega)|^2 + (\omega_{ij}/\omega)^2 |1 - |C_{ij}(\omega)|^2], \quad (26b)$$

where

$$\bar{V}_j(\omega) = \bar{Y}_{j1}(\omega); \quad C_{ij}(\omega) = [\bar{Y}_{j1}(\omega) / \bar{Y}_{i1}(\omega)], \quad (27)$$

and it is noted that the first of Eq. (19) is a specific case of the first of Eq. (27). Using Eqs. (21) and (25), an effective loss factor $\eta_{e1}(\omega)$ can be properly and conventionally defined in the form

$$\eta_{e1}(\omega) = [\bar{\pi}_{e1}(\omega) / \bar{\epsilon}_{f1}(\omega)], \quad (28a)$$

and, using Eqs. (22) and (23), one further derives

$$\eta_{e1}(\omega) = [\eta_{p1}(\omega) / \bar{\epsilon}_{f1}(\omega)]; \quad \eta_{e1}(\omega) = \eta_{b1}(\omega) [1 + \zeta(\omega)]^{-1}, \quad (28b)$$

where $\zeta(\omega)$ is the ratio of the stored energy in the satellite harmonic oscillators and in the couplings to the stored energy in the master harmonic oscillator; namely,

$$\zeta(\omega) = [\bar{\varepsilon}_{s1}(\omega) / \bar{\varepsilon}_1(\omega)] \geq 0, \quad (29a)$$

and the relationship between the loss factor $\eta_{b1}(\omega)$ of a sort and the prevailing loss factor $\eta_{p1}(\omega)$ is

$$\eta_{p1}(\omega) = [\eta_{b1}(\omega) \bar{\varepsilon}_1(\omega)]; \quad \bar{\varepsilon}_1(\omega) = (1/2) [1 + (\omega_{11} / \omega)^2]. \quad (30)$$

[cf. Eqs. (14) through (16) and (24).] It is noted that the equality sign in Eq. (29a) occurs only when the master harmonic oscillator is rendered onto isolation. [cf. Eq. (17).] Equation (28b) and the inequality in Eq. (29a) leads, in turn, to the inequality

$$\eta_{e1}(\omega) \leq \eta_{b1}(\omega). \quad (29b)$$

It is emphasized that the loss factors $\eta_{p1}(\omega)$, $\eta_{b1}(\omega)$ and $\eta_{e1}(\omega)$ are, by definition, ratios that are independent of the normalized absolute square of the response; namely $|V_1(\omega)|^2$, of the master harmonic oscillator. Indeed, these loss factors are by all means intensive, by no means extensive, properties of the energetics of the complex.

Investigation of the extensive properties of the complex are deferred to subsequent reports. Again, it is recalled that the relationship between the effective loss factor $\eta_{e1}(\omega)$ and the prevailing loss factor $\eta_{p1}(\omega)$ is largely significant in the vicinity of the insitu resonance frequencies of the master harmonic oscillator. The plural designation of the resonance frequencies is predicated on a phenomenon that couplings, among harmonic oscillators of like and nearly like resonance frequencies, brings about a removal of the degeneracies among these resonance frequencies; this removal yields a multiplicity of resonance

frequencies for the complex as a whole. (The “resonance frequency” in this context include “anti-resonance frequencies” as well [1].) This multiplicity is derived from the requirement that in the vicinity and at these resonance frequencies $|Y_{11}(\omega)|$, as stated in Eq. (19), exhibits ridges and associated peaks, as well as, valleys and associated nadirs. The range and distribution of this multiplicity of resonance frequencies are dependent on the nature of the couplings and their strengths [1]. A frequency within that range is designated (ω_1). In summary and in this vein

$$\bar{Z}_1(\omega) = [\bar{Y}_{11}(\omega)]^{-1}; \left. \begin{array}{l} \eta_{p1}(\omega) \\ \eta_{b1}(\omega) \\ \eta_{e1}(\omega) \end{array} \right\} = \left\{ \begin{array}{l} 1 \\ 2 [1 + (\omega_{11} / \omega)^2]^{-1} \\ [\bar{\epsilon}_{11}(\omega)]^{-1} \end{array} \right\} \text{Re}\{\bar{Z}_1(\omega)\};$$

$$\eta_{e1}(\omega) \leq \eta_{p1}(\omega); \quad \bar{\epsilon}_{11}(\omega) \approx 1, \quad \omega_1 = \omega; \quad \omega_{11} \leq \omega_1 \leq \omega_{o1}. \quad (31)$$

The lower limit, in the last of Eq. (31), is set when the masses in the satellite harmonic oscillators respond with the same velocity as that of the master harmonic oscillator; the low setting is thus commensurate with the resonance frequency of an isolated harmonic oscillator; as defined in Section IVA. The upper limit, in the last of Eq. (31), is set when the masses in the satellite harmonic oscillators are held motionless; the upper setting is thus commensurate with the resonance of a complex composed of a master harmonic oscillator that is coupled to blocked satellite harmonic oscillators; this complex is defined in Section IVB. [cf. Eq. (18).] Again, Eq. (31) states that in the presence of couplings between the master harmonic oscillator and the satellite harmonic oscillators, the prevailing loss factor $\eta_{p1}(\omega)$ tends to exaggerate the effective loss factor $\eta_{e1}(\omega)$ of the complex, at least, in the vicinity of the resonance frequency (ω_1) of the master harmonic oscillator. Moreover, the exaggeration is most severe when most of the stored energy in the complex resides in the couplings and in the satellite harmonic oscillators, so that, the stored energy

ratio $\zeta(\omega)$, stated in Eq. (29a), substantially exceeds unity. This statement is not surprising. Comparing Eq. (23) with Eq. (28a) indicates that in the definition of $\eta_{p1}(\omega)$ only the normalized stored kinetic energy in the master harmonic oscillator is accounted for among the stored energies in the complex. Doubling the stored kinetic energy in the definition of $\eta_{p1}(\omega)$, in an effort to account for the stored potential energy in the master harmonic oscillator, does not alleviate this accounting deficiency. Accounting only for the stored energy in the master harmonic oscillator is unsatisfactory in a complex in which the couplings drive satellite harmonic oscillators, notwithstanding that the master harmonic oscillator alone is externally driven. The exception occurs only when the master harmonic oscillator is in isolation. It emerges, therefore, that with this exception acknowledged and discussed in Section IV, the use of the prevailing loss factor $\eta_{p1}(\omega)$ as a bonafide loss factor may often raise the question: Where did the energy go? This issue becomes particularly relevant in those situations for which the stored energy ratio $\zeta(\omega) [= \bar{\epsilon}_{s1}(\omega)/\bar{\epsilon}_1(\omega)]$ is large compared with unity. It is explained herein that the energy did not go anywhere, it is merely and mistakenly discounted. In this sense and although they appear related, the prevailing loss factor $\eta_{p1}(\omega)$ and the effective loss factor $\eta_{e1}(\omega)$ are not, in general, consistent; the latter loss factor being the real one. Nonetheless, a number of publications, dealing with structural fuzzies, employ the prevailing loss factor for real [9-12].

To further analyze the relationship and the contrast between the prevailing and the effective loss factors, a more explicit definition of the quantities and parameters that describe the complex is required. It may also be useful, at this stage, to sacrifice a little in generality to gain much simplicity in the analytical descriptions and their manipulations. For this purpose subsequent consideration is focused on a complex in which the satellite harmonic oscillators are not coupled to each other. In this complex, couplings, if any, are only between the master harmonic oscillator and the individual satellite harmonic oscillators.

VI. THE PREVAILING LOSS FACTOR FOR A COMPLEX IN WHICH THE SATELLITE HARMONIC OSCILLATORS ARE UNCOUPLED TO EACH OTHER.

For this complex certain elements in the impedance matrix are equal to zero. Indeed, these zero elements, as well as those that survive, can be identified by multiplying all elements by the factor $[\delta_{ji} + (\delta_{j1} + \delta_{i1})(1 - \delta_{ji})]$; e.g., in Eq. (4) a replacement needs to be implemented in the form

$$\left. \begin{array}{l} \bar{Z}_{ji}^-(\omega) \\ \bar{Z}_{ji}^+(\omega) \\ \bar{Z}_{ji}(\omega) \end{array} \right\} \rightarrow \left\{ \begin{array}{l} \bar{Z}_{ji}^-(\omega) \\ \bar{Z}_{ji}^+(\omega) \\ \bar{Z}_{ji}(\omega) \end{array} \right\} [(\delta_{ji} + (\delta_{j1} + \delta_{i1})(1 - \delta_{ji}))]. \quad (32)$$

Substituting Eq. (32) in Eq. (1b) and then deriving Eq. (6), one finds a highly simplified form for the insitu normalized admittance $\bar{Y}_{11}(\omega)$ for the master harmonic oscillator

$$\bar{Y}_{11}(\omega) = [\bar{Z}_{11}(\omega) + \sum_{j=2}^N \bar{Z}_{1j}(\omega) C_{1j}(\omega)]^{-1}, \quad (33)$$

where

$$C_{1j}(\omega) = [\bar{Y}_{j1}(\omega) / \bar{Y}_{11}(\omega)] = -[\bar{Z}_{j1}(\omega) / \bar{Z}_{jj}(\omega)]. \quad (34)$$

Again, clarity can be gained, without too much loss in generality, by suppressing the mass and gyroscopic coupling parameters. Accordingly, the parameters $\bar{M}_{ji}(1 - \delta_{ji})$ and $\bar{G}_{ji}(\omega)(1 - \delta_{ji})$ are set equal to zero in Eq. (4). With this suppression

$$\bar{Z}_{ji}(\omega) = \bar{Z}_{ji}^+(\omega) = -\bar{Z}_{ji}^-(\omega); \quad \bar{Z}_{ji}(\omega) = \bar{Z}_{ij}(\omega);$$

$$j \neq i . \quad (35)$$

Substituting Eq. (35) in Eq. (33) and rearranging terms and factors, one derives

$$\bar{Y}_{11}(\omega) = \{[\bar{Z}_{11}^-(\omega) + \bar{Z}_{c1}(\omega)]\}^{-1}; \quad \bar{Z}_1(\omega) = [\bar{Z}_{11}^-(\omega) + \bar{Z}_{c1}(\omega)];$$

$$\bar{Z}_{c1}(\omega) = \sum_{j=2}^N \bar{Z}_{cj}(\omega); \quad \bar{Z}_{cj}(\omega) = \bar{Z}_{jj}^-(\omega)\bar{Z}_{1j}^-(\omega) [\bar{Z}_{jj}^-(\omega) + \bar{Z}_{1j}^-(\omega)]^{-1},$$

$$(36)$$

where $\bar{Z}_{cj}(\omega)$ is the normalized impedance contributed to the master harmonic oscillator by the coupled (j)th satellite harmonic oscillator and its coupling to that master harmonic oscillator. It is remarkable that \bar{Z}_{cj} is constructed of merely the parallel combination of the normalized impedance $\bar{Z}_{jj}^-(\omega)$ of the satellite harmonic oscillator in isolation with its normalized coupling impedance $\bar{Z}_{1j}^-(\omega)$ to the master harmonic oscillator. Also remarkable is that the first term in the normalized impedance $\bar{Z}_1(\omega)$ is the normalized impedance $\bar{Z}_{11}^-(\omega)$ of the master harmonic oscillator in isolation. The thorough investigation of this structure of $\bar{Z}_1(\omega)$ is deferred; in this report the concern is with investigating the loss factors that this normalized impedance may harbor. From Eqs. (12), (20) and (36), one finds that the prevailing loss factor $\eta_{p1}(\omega)$ may be expressed in the form

$$\eta_{p1}(\omega) = [\eta_{p1}^o(\omega) + \eta_{c1}(\omega)] ; \quad \eta_{c1}(\omega) = \sum_{j=2}^N \eta_{pj}(\omega) ;$$

$$\eta_{pj}(\omega) = \frac{[|\bar{Z}_{jj}^-(\omega)|^2 \operatorname{Re}\{\bar{Z}_{1j}^-(\omega)\} + |\bar{Z}_{1j}^-(\omega)|^2 \operatorname{Re}\{\bar{Z}_{jj}^-(\omega)\}][|\bar{Z}_{jj}(\omega)|^2]^{-1}}{1} , \quad (37)$$

where $\eta_{p1}^o(\omega)$ is the contribution of the master harmonic oscillator to its own prevailing loss factor and $\eta_{pj}(\omega)$ is the contribution of the coupled (j)th satellite harmonic oscillator and its coupling to the prevailing loss factor $\eta_{p1}(\omega)$. Since $\eta_{pj}(\omega)$ is positive definite, the attachment of each satellite harmonic oscillator to the master harmonic oscillator always increase the prevailing loss factor $\eta_{p1}(\omega)$, initially from its threshold at $\eta_{p1}^o(\omega)$.

Investigating, Eqs. (36) and (37) in particular, one recognizes immediately that provided the individual loss factors (η_{jj}) and (η_{1j}) are reasonably small compared with unity, the contribution $\eta_{pj}(\omega)$ to the prevailing loss factor $\eta_{p1}(\omega)$ by the (j)th satellite harmonic oscillator is significant in a frequency band that is $(\omega_{oj}\eta_{oj})$ wide and is centered about the **resonance frequency** (ω_{oj}). The resonance frequency (ω_{oj}) and the **resonance frequency span** ($\omega_{oj}\eta_{oj}$) of the (j)th harmonic oscillator are defined by the insitu normalized impedance $\bar{Z}_{jj}(\omega)$. This normalized impedance is that of the (j)th satellite harmonic oscillator with the master harmonic oscillator blocked. In contrast to the normalized impedance $\bar{Z}_{cj}(\omega)$ defined in Eq. (36), the normalized impedance $\bar{Z}_{jj}(\omega)$ is constructed of merely the series combination of the normalized impedance $\bar{Z}_{jj}^-(\omega)$ of the satellite harmonic oscillator in isolation with its normalized coupling impedance $\bar{Z}_{1j}^-(\omega)$ to the master harmonic oscillator, notwithstanding that $\bar{Z}_{jj}(\omega)$ is an inverse factor in $\bar{Z}_{cj}(\omega)$. At, and in the vicinity of the resonance in this (j)th harmonic oscillator, the following relationship needs to be satisfied:

$$\text{Im} \{Z_{jj}(\omega)\} \simeq 0 \quad \text{and} \quad \text{Re} \{Z_{jj}(\omega)\} \ll 1, \quad j \geq 2. \quad (38)$$

[cf. Eq. (12b).] Equation (38), as Eqs. (4) and (35) attest, defines in turn

$$(\bar{M}_{jj}\eta_{oj}) = [(\omega_{jj}/\omega_{oj})^2 \eta_{jj} + (\omega_{1j}/\omega_{oj})^2 \eta_{1j}];$$

$$\bar{M}_{jj} = (M_{jj}/M_{11}); \quad \omega_{jj}^2 = (K_{jj}^o/M_{11}); \quad \omega_{1j} = (K_{1j}^o/M_{11}), \quad (39a)$$

$$\bar{M}_{jj} \simeq [(\omega_{jj}/\omega_{oj})^2 + (\omega_{1j}/\omega_{oj})^2]. \quad (39b)$$

Defining a **span function** $U_j(\omega, \omega_{oj}, \eta'_{oj})$; e.g.,

$$U_j(\omega, \omega_{oj}, \eta'_{oj}) =$$

$$\{U[\omega - \omega_{oj} (1 - \eta'_{oj})] - U[\omega - \omega_{oj} (1 + \eta'_{oj})]\};$$

$$\eta'_{oj} = (\eta_{o1} + \eta_{oj}); \quad \eta_{o1} = \eta_{p1}^o(\omega_{oj}), \quad (40)$$

where U is the unit step function, Eq. (37) may be approximated in the more explicit form

$$\eta_{p1}(\omega) = [\eta_{p1}^o(\omega) + \eta_{c1}(\omega)];$$

$$\eta_{c1}(\omega) = \sum_{j=2}^N \eta_{pj}(\omega_{oj}) U_j(\omega, \omega_{oj}, \eta'_{oj});$$

$$\eta_{pj}(\omega_{oj}) = [R_j(\omega_{oj})/(\eta_{oj})] ;$$

$$R_j(\omega_{oj}) = (\omega_{1j}/\omega_{oj})^4 [1 + (\omega_{jj}/\omega_{1j})^2 \eta_{jj} \eta_{1j}] (\bar{M}_{jj})^{-1} . \quad (41)$$

Clearly, $R_j(\omega_{oj})$ is directly dependent on the presence of couplings between the satellite harmonic oscillators and the master harmonic oscillator. In the absence of such couplings, $R_j(\omega_{oj})$ is identically equal to zero and the terms that are summed over in Eq. (41) are all zeros and Eq. (12a) is appropriately recovered. On the other hand and just as clearly, if couplings are present, a resonating satellite harmonic oscillator, as defined in Eq. (38), which possesses a loss factor (η_{oj}) , as defined in Eq. (39), that approaches zero contributes singularly to the prevailing loss factor. This singularity in the contribution of a single harmonic oscillator is addressed in some publications [9-12]. In particular, if the span $(\omega_{oj} \eta'_{oj})$ of the (j) th satellite harmonic oscillator harbors but a single satellite harmonic oscillator, Eq. (41) becomes

$$\eta_{p1}(\omega) = [\eta_{p1}^o(\omega) + \eta_{c1}(\omega)] ; \quad \eta_{c1}(\omega_{oj}) = \eta_{pj}(\omega_{oj}) ;$$

$$\eta_{pj}(\omega_{oj}) = [R_j(\omega_{oj})/(\eta_{oj})] , \quad (42)$$

and the potential singularity in the contribution of that satellite harmonic oscillator assumes a more obvious connotation. The satellite harmonic oscillators that resonate within the span that is defined by U_j , constitute the (j) th cell of satellite harmonic oscillators. Then Eq. (42) is said to be valid for a (j) th cell that contains a single satellite harmonic oscillator. It is noted, in passing, that in a (j) th cell that hosts zero satellite harmonic oscillators, $\eta_{c1}(\omega_{oj}) \equiv 0$. Since it is prescribed that the resonating harmonic oscillators contribute dominantly, the influence of the non-resonant harmonic oscillators is assumed to

be negligible and hence the validity of the statement just made. The barren cells cover, by definition, frequency ranges that lie outside the resonance frequency spans of hosting cells.

On the other hand, cells may exist in which a number of satellite harmonic oscillators may be hosted; within the span that is defined by U_j a number of resonating harmonic oscillators are contained. The resonances of these satellite harmonic oscillators are in reference to a blocked master harmonic oscillator. These resonating hosted harmonic oscillators contribute prominently and collectively to the portion $\eta_{c1}(\omega)$ of the prevailing loss factor as stated in the sum in Eq. (41). In this connection, there are treatises that claim that the collective contribution to the prevailing loss factor $\eta_{c1}(\omega)$ of satellite harmonic oscillators that are coupled and hosted by a well endowed cell, is independent of the loss factors η_{oj} that are associated with these individual satellite harmonic oscillators. It is implied, thereby, that even if individual satellite harmonic oscillators possess loss factors that in a single occupancy would contribute singularly to the prevailing loss factor, in a multiple occupancy, these singular contributions are suppressed [9-12]. The measure of multiplicity is seldom defined beyond the designation of "many, many, many" and the notion of a cell of satellite harmonic oscillators is rarely referenced [9]. In the mid-sixties, when SEA was initiated and fostered, it was premised that when one deals with a single isolated dynamic system, the behavior is simply accounted for; when one deals with two interacting dynamic systems, accounting for the joint behavior is troublesome. However, when one deals with three or more interacting dynamic systems, one averts difficulties by using statistics. Is that what is meant by (many)³? To answer this question, let the factors $\eta_{pj}(\omega_{oj})$, in the terms of the sum in Eq. (41), be represented by a "typical" factor to which a weight of $(\Delta_j N)$ is assigned, where $(\Delta_j N)$ is the number of satellite harmonic oscillators that significantly contribute to the sum within the resonance frequency span that is defined by the span function U_j ; namely, the contributions of those resonating satellite harmonic oscillators that reside in the (j)th cell. With this representation, Eq. (41) may be approximated in the form

$$\langle \eta_{p1}(\omega) \rangle = [\eta_{p1}^o(\omega) + \langle \eta_{c1}(\omega) \rangle] ; \quad \langle \eta_{c1}(\bar{\omega}_{oj}) \rangle \simeq \langle \eta_{pj}(\bar{\omega}_{oj}) \rangle (\Delta_j N) ;$$

$$\langle \eta_{pj}(\bar{\omega}_{oj}) \rangle = [\langle R_j(\bar{\omega}_{oj}) \rangle / \langle \eta_{oj} \rangle] , \quad (43)$$

where the angular brackets imply the averaging of the enclosed quantity, $(\bar{\omega}_{oj})$ is the center frequency of the (j) th cell and a flimsy, but probable, form of averaging procedure is implemented; e.g., $\langle R_j(\bar{\omega}_{oj}) \rangle$ and $\langle \eta_{oj} \rangle$ are the implied averages of $R_j(\omega_{oj})$ and (η_{oj}) over the values that they have in the (j) th cell and, yet, it is the product of these quantities that is being averaged. More rigorous averaging procedures and factorizations may be contemplated; however, those lie beyond the intended scope for this report. [It is recognized that adjacent cells may host some of the same resonating satellite harmonic oscillators. In this manner the center frequency $(\bar{\omega}_{oj})$ may assume, in certain frequency ranges, a quasi-continuous character. Some aspects of these and other considerations are to be assessed, in conjunction with computations, in companion reports.] If $(\Delta_j N)$ is greater than two, which according to the original premise is an adequate condition for applying statistics, one finds that

$$\langle n_j(\bar{\omega}_{oj}) \rangle (\bar{\omega}_{oj}) \langle \eta_{oj} \rangle \simeq (\Delta_j N) > 2 , \quad (44)$$

where $\langle n_j(\bar{\omega}_{oj}) \rangle$ is the **modal density** of the (j) th cell of satellite harmonic oscillators and it is recognized that Eq. (44), by definition, satisfies the criterion of **modal overlap** in the (j) th cell [1]. Substituting Eq. (44) in Eq. (43), yields

$$\langle \eta_{p1}(\omega) \rangle = [\eta_{p1}^o(\omega) + \langle \eta_{c1}(\omega) \rangle] ;$$

$$\langle \eta_{c1}(\bar{\omega}_{oj}) \rangle \simeq \langle R_j(\bar{\omega}_{oj}) \rangle (\bar{\omega}_{oj}) \langle n_j(\bar{\omega}_{oj}) \rangle . \quad (45)$$

Equation (45), which apriori satisfies the modal overlap condition, purports to be independent of the loss factors (η_{oj}) of the individual satellite harmonic oscillators. Purports because Eq. (45) is not actually independent of the loss factor $\langle \eta_{oj} \rangle$. Through Eq. (44), $\langle \eta_{oj} \rangle$ is merely called by another name. The renaming cannot hide the implied presence of the inverse of this averaged loss factor in its full regalia, in Eq. (45). [cf. Eq. (43).] Equation (44) declares that if $\langle \eta_{oj} \rangle \rightarrow 0$, $[(\bar{\omega}_{oj}) \langle n_j(\bar{\omega}_{oj}) \rangle]$ must become (many)³ to maintain the inequality stated in this equation, notwithstanding that if some of the loss factors (η_{oj}) approach zero, the convergence of terms in Eq. (41) to those in Eq. (43) are in question. The (many)³ dilemma and its connotation are, thereby, exposed although they are not rigorously resolved.

It emerges, therefore, that the higher value for the prevailing loss factor $\eta_{p1}(\omega)$ is more reflective of the inhibition of the stored energy in the master harmonic oscillator, as a fraction of the stored energy in the complex as a whole, than it is reflective of the efficiency by which the external input power is dissipated. Indeed, the higher contribution of the couplings to $\eta_{p1}(\omega)$ occurs at frequencies at which the satellite harmonic oscillators in a cell are at resonance under conditions that the master harmonic oscillator is essentially blocked. These frequencies are precisely those at which the stored energy ratio $\zeta(\omega)$, stated in Eq. (29a), attains values that substantially exceed unity. The prevailing loss factor $\eta_{p1}(\omega)$, as such, hardly addresses the efficiency with which the normalized external input power is dissipated once it entered the complex. It is the effective loss factor $\eta_{e1}(\omega)$ that addresses the efficiency of this dissipation; $\eta_{e1}(\omega)$ is, therefore, the real loss factor.

VII. THE EFFECTIVE LOSS FACTOR FOR A COMPLEX IN WHICH THE SATELLITE HARMONIC OSCILLATORS ARE UNCOUPLED TO EACH OTHER.

To determine the effective loss factor $\eta_{e1}(\omega)$, in addition to the determination of the prevailing loss factor $\eta_{p1}(\omega)$, the determination of the normalized stored energy $\bar{\bar{\epsilon}}_{t1}(\omega)$ in the complex is also needed. [cf. Eq. (28).] Imposing the condition stated in Eqs. (32), (34) and (35) on Eqs. (25) and (26), simplified forms for the normalized stored energy and its terms are derived

$$\bar{\bar{\epsilon}}_{t1}(\omega) = \bar{\bar{\epsilon}}_1(\omega) + \bar{\bar{\epsilon}}_{s1}(\omega); \quad \bar{\bar{\epsilon}}_{s1}(\omega) = \sum_{j=2}^N \bar{\bar{\epsilon}}_{sj}(\omega);$$

$$\bar{\bar{\epsilon}}_{sj}(\omega) = [\bar{\bar{\epsilon}}_j(\omega) + \bar{\bar{\epsilon}}_{1j}(\omega)], \quad (46)$$

$$\bar{\bar{\epsilon}}_j(\omega) = (1/2) |\bar{Z}_{1j}^-(\omega) / \bar{Z}_{jj}(\omega)|^2 [\bar{M}_{jj} + (\omega_{jj} / \omega)^2];$$

$$\bar{\bar{\epsilon}}_{1j}(\omega) = (1/2) |\bar{Z}_{jj}^-(\omega) / \bar{Z}_{jj}(\omega)|^2 (\omega_{1j} / \omega)^2; \quad j \geq 2. \quad (47)$$

Substituting Eq. (47) in Eq. (46), one obtains

$$\bar{\bar{\epsilon}}_{sj}(\omega) = (1/2) \{ |\bar{Z}_{1j}^-(\omega)|^2 [\bar{M}_{jj} + (\omega_{jj} / \omega)^2] + |\bar{Z}_{jj}^-(\omega)|^2 (\omega_{1j} / \omega)^2 \} [|\bar{Z}_{jj}(\omega)|^2]^{-1}. \quad (48)$$

[cf. Eq. (36).] Utilizing Eqs. (39) through (41), one can show that at, and in the vicinity of the resonances, as defined in Eq. (38), Eqs. (46) through (48) assume yet simpler and more explicit forms

$$\begin{aligned}\bar{\bar{\epsilon}}_{t1}(\omega) &= \bar{\bar{\epsilon}}_1(\omega) + \bar{\bar{\epsilon}}_{s1}(\omega); & \bar{\bar{\epsilon}}_1(\omega) &= (1/2) [1 + (\omega_{11}/\omega)^2]; \\ \bar{\bar{\epsilon}}_{s1}(\omega) &= \sum_{j=2}^N \bar{\bar{\epsilon}}_{sj}(\omega_{oj}) U_j(\omega, \omega_{oj}, \eta'_{oj}),\end{aligned}\quad (49)$$

where

$$\bar{\bar{\epsilon}}_{sj}(\omega_{oj}) = [R'_j(\omega_{oj})/(\eta_{oj})^2];$$

$$\begin{aligned}R'_j(\omega_{oj}) \\ = (\omega_{1j}/\omega_{oj})^4 [(1 + \eta_{1j}^2) + (1/2) \{(\omega_{jj}/\omega_{1j})^2 \eta_{jj}^2 - (\omega_{1j}/\omega_{oj})^2 \eta_{1j}^2\}] (\bar{M}_{jj})^{-1}.\end{aligned}\quad (50)$$

In particular, if the span $(\omega_{oj} \eta'_{oj})$ of the (j) th harmonic oscillator harbors but a single satellite harmonic oscillator, Eq. (49) becomes

$$\begin{aligned}\bar{\bar{\epsilon}}_{t1}(\omega) &= \bar{\bar{\epsilon}}_1(\omega) + \bar{\bar{\epsilon}}_{s1}(\omega); & \bar{\bar{\epsilon}}_1(\omega_{oj}) &= (1/2) [1 + (\omega_{11}/\omega_{oj})^2]; \\ \bar{\bar{\epsilon}}_{s1}(\omega_{oj}) &= \bar{\bar{\epsilon}}_{sj}(\omega_{oj}); & \bar{\bar{\epsilon}}_{sj}(\omega_{oj}) &= [R'_j(\omega_{oj})/(\eta_{oj})^2].\end{aligned}\quad (51)$$

[cf. Eq. (42).] Moreover, following an analogous statistical procedure with regard to Eq. (49) that is employed to transit from Eq. (41) to Eq. (43), one obtains

$$\begin{aligned}\langle \bar{\epsilon}_{t1}(\omega) \rangle &= \bar{\epsilon}_1(\omega) + \langle \bar{\epsilon}_{s1}(\omega) \rangle ; & \bar{\epsilon}_1(\omega) &= (1/2) [1 + (\omega_{11}/\omega)^2] ; \\ \langle \bar{\epsilon}_{s1}(\bar{\omega}_{oj}) \rangle &= \langle \bar{\epsilon}_{sj}(\bar{\omega}_{oj}) \rangle (\Delta_j N) ; \\ \langle \bar{\epsilon}_{sj}(\bar{\omega}_{oj}) \rangle &= [\langle R'_j(\bar{\omega}_{oj}) \rangle / (\langle \eta_{jo} \rangle)^2] .\end{aligned}\quad (52)$$

It is observed that except for terms that are dependent on the individual loss factors (η_{jj}) and (η_{1j}) , $R_j(\omega_{oj})$, as stated in Eq. (41), and $R'_j(\omega_{oj})$, as stated in Eq. (50), are equal. Indeed, it can be argued that as long as the individual loss factors (η_{jj}) and (η_{1j}) are at least an order of magnitude smaller than unity, the terms that are so dependent may be neglected and then

$$R_j(\omega_{oj}) \simeq (\omega_{1j}/\omega_{oj})^4 (\bar{M}_{jj})^{-1} \simeq R'_j(\omega_{oj}) . \quad (53)$$

From Eqs. (17), (28), (42) and (51) and under the approximation that is Eq. (53), the effective loss factor $\eta_{e1}(\omega_{oj})$, for a (j) th cell that harbors a single satellite harmonic oscillator, may be expressed in the form

$$\eta_{e1}(\omega_{oj}) = [\eta_{e1}^o(\omega_{oj}) + \eta_{oj}\zeta_j(\omega_{oj})] [1 + \zeta_j(\omega_{oj})]^{-1} . \quad (54)$$

The quantity $\zeta_j(\omega_{oj})$ is the ratio of the normalized energy $\bar{\epsilon}_{sj}(\omega_{oj})$ that is stored in the singly occupied (j) th cell and in the coupling to the normalized energy $\bar{\epsilon}_1(\omega_{oj})$ that is

stored in the master harmonic oscillator. Both stored energies are evaluated at the resonance frequency (ω_{oj}); i.e.

$$\zeta_j(\omega_{oj}) = [\bar{\epsilon}_{sj}(\omega_{oj})/\bar{\epsilon}_1(\omega_{oj})] = [\bar{\bar{\epsilon}}_{sj}(\omega_{oj})/\bar{\bar{\epsilon}}_1(\omega_{oj})] . \quad (55)$$

Similarly, from Eqs. (17), (28), (43) and (52) and under the approximation that is Eq. (53), the effective loss factor $\eta_{e1}(\bar{\omega}_{oj})$, for a (j)th cell that harbors a number ($\Delta_j N$) of satellite harmonic oscillators, may be expressed in the form

$$\langle \eta_{e1}(\bar{\omega}_{oj}) \rangle = [\eta_{e1}^o(\bar{\omega}_{oj}) + \langle \eta_{oj} \rangle \langle \zeta_j(\bar{\omega}_{oj}) \rangle] [1 + \langle \zeta_j(\bar{\omega}_{oj}) \rangle]^{-1} . \quad (56)$$

The quantity $\langle \zeta_j(\bar{\omega}_{oj}) \rangle$ is the ratio of the normalized energy $\langle \bar{\epsilon}_{s1}(\bar{\omega}_{oj}) \rangle$ that is stored in a multiply occupied (j)th cell and in the couplings to the normalized energy $\bar{\epsilon}_1(\bar{\omega}_{oj})$ that is stored in the master harmonic oscillator. Both stored energies are evaluated at the centered frequency ($\bar{\omega}_{oj}$) of the (j)th cell; i.e.

$$\langle \zeta_j(\bar{\omega}_{oj}) \rangle = [\langle \bar{\epsilon}_{s1}(\bar{\omega}_{oj}) \rangle / \bar{\epsilon}_1(\bar{\omega}_{oj})] = [\langle \bar{\bar{\epsilon}}_{s1}(\bar{\omega}_{oj}) \rangle / \bar{\bar{\epsilon}}_1(\bar{\omega}_{oj})] , \quad (57)$$

where $\langle \bar{\epsilon}_{s1}(\bar{\omega}_{oj}) \rangle$ and $\bar{\epsilon}_1(\bar{\omega}_{oj})$ are stated in Eq. (52). [cf. Eqs. (51) and (55).]

Equations (54) and (56) are reminiscent of an expression for the effective loss factor of a structural fuzzy derived via SEA [6]. The resemblance between Eqs. (54) and (56) in this report and Eq. (17a) of Reference 6, is clearly not accidental. All express the same concept under different implied conditions; e.g., in Eq. (54) one satellite harmonic oscillator versus several in Eq. (56). In Eq. (17a) of Reference 6, it is implied that, in addition, there may be included in the formalism also a number of resonating master harmonic oscillators that reside with a corresponding cell. Nonetheless, many of the discussions, interpretations and conclusions presented in Reference 6 are relevant to

Eqs. (54) and (56). Thus, for example, Eq. (54) indicates that the effective loss factor $\eta_{e1}(\omega_{oj})$ can be either increased or decreased from $\eta_{e1}^o(\omega_{oj})$ by coupling the master harmonic oscillator to a satellite harmonic oscillator the loss factor (η_{oj}) of which is either higher or lower than $\eta_{e1}^o(\omega_{oj})$, respectively. Other examples can be similarly treated and many will be in companion reports. In these companion reports, in addition, extensions will be made to include couplings among the satellite oscillators and to couplings that possess mass and gyroscopic parameters. The extensions will be aided by computational experiments. To these companion reports, this report serves as a mere introduction and as a useful analytical guide.

A final remark may be in order: In the formalism of the loss factors pursued in this report, it becomes clear that in seeking to establish design criteria for the loss factors of a complex, it is not merely the maximization of the values of the loss factors that is of significance. The placement of these maximal loss factors at frequencies where they are most useful is also a subject for consideration. Often these frequencies are commensurate with the insitu resonance frequencies of the complex and these frequencies are not necessarily located where the highest values for the prevailing and/or the effective loss factors reside. These kinds of considerations will prominently feature in the companion reports to come.

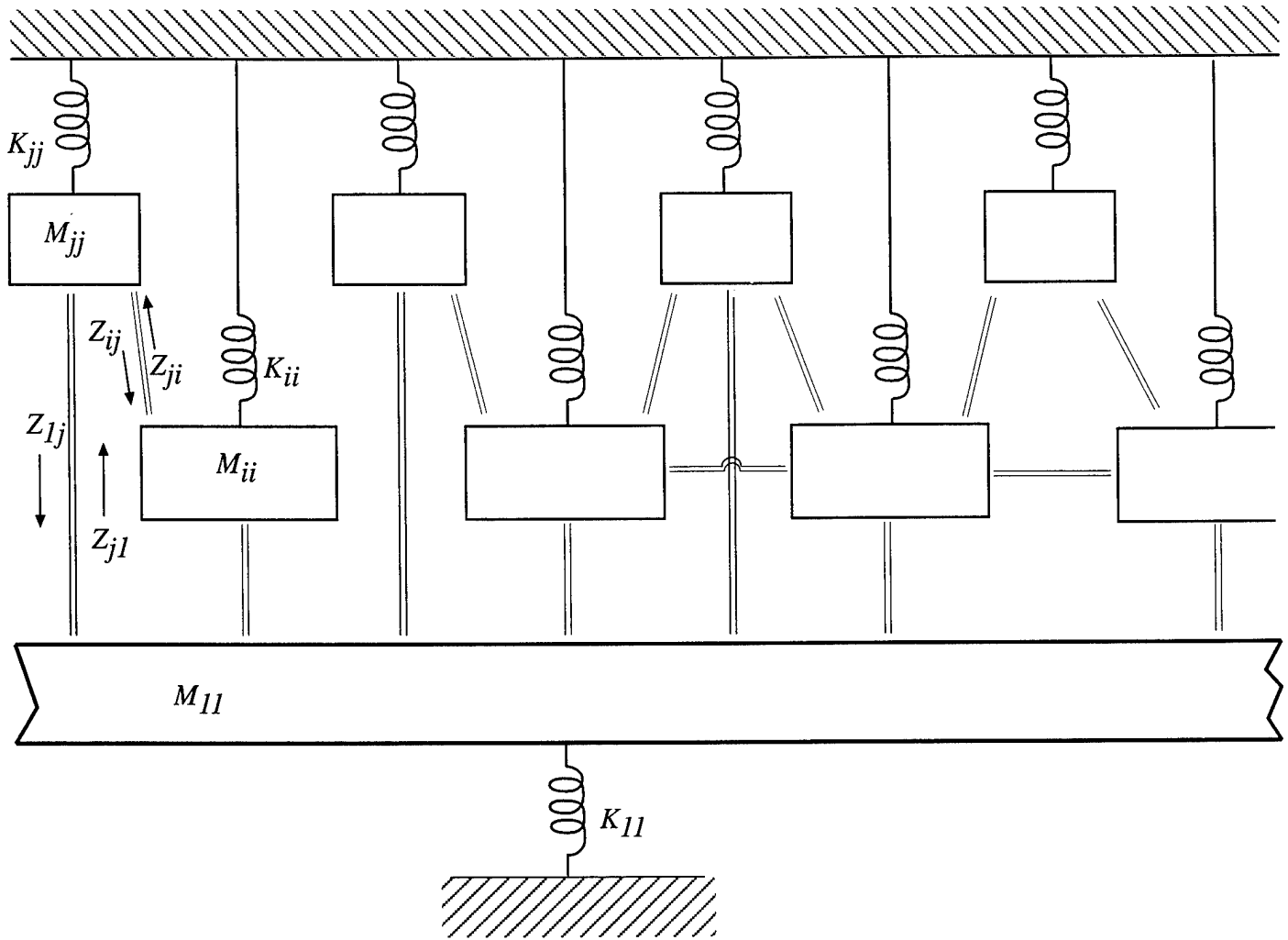

———— couplings between harmonic oscillators.

$\{K_{jj}, M_{jj}\}$ defines the (j)th harmonic oscillator.

Fig. 1 A complex composed of a number of coupled harmonic oscillators. The first harmonic oscillator is designated as the master and the others are designated as the satellites.

REFERENCES

1. R.H. Lyon, Statistical Energy Analysis of Dynamic Systems: Theory and Applications (MIT, Cambridge, 1975); R.H. Lyon and R.G. DeJong, Theory and Application of Statistical Energy Analysis (Butterworth-Heinemann, Boston, 1995).
2. C. Soize, "Probabilistic structural modeling in linear dynamic analysis of complex mechanical systems," *Rech. Aerosp*, 1986-3, 23-48 (1986) and "A model and numerical method in the medium frequency range for vibroacoustic predictions using the theory of structural fuzzy," *J. Acoust. Soc. Am.* 94, 849-865 (1993).
3. P.W. Smith, Jr. and R.H. Lyon, Sound and Structural Vibration, NASA CR-160 (U.S. Department of Commerce, Washington, D.C. 1965).
4. R.H. Lyon, "Statistical energy analysis and structural fuzzy," *J. Acoust. Soc. Am.* 97, 2878-2881 (1995).
5. P.W. Smith, Jr., "Statistical models of coupled dynamic systems and transition from weak to strong coupling," *J. Acoust. Soc. Am.* 65, 695-698 (1979); and K.L. Chandiramani, "Some simple models describing the transition from weak to strong coupling in statistical energy analysis" *J. Acoust. Soc. Am.* 63, 1081-1083 (1978).
6. G. Maidanik and J. Dickey, "Design criteria for the damping effectiveness of structural fuzzies," *J. Acoust. Soc. Am.* 100, 2029-2033 (1996); and "On the fuzz in a structural fuzzy," *Proceedings of Internoise 96*, Book 3, 1297-1302 (1996).
7. L. Meirovitch, Computational Methods in Structural Dynamics (Sijthoff and Noordhoff, 1980).
8. C. Lesuer, Rayonnement Acoustique des Structures (Editions Eyrolles, Paris, 1988).

9. A.D. Pierce, V.W. Sparrow and D.A. Russell, "Fundamental structural acoustics idealizations for structures with fuzzy internals," ASME J. Vib. Acoust. 117, 1-10 (1995).
10. M. Strasberg and D. Feit, "Vibration damping of large structures induced by attached small resonant substructures," J. Acoust. Soc. Am. 94, 335-344 (1996).
11. M. Strasberg, "Continuous structures as 'fuzzy' substructures," J. Acoust. Soc. Am. 100, 3456-3459 (1996).
12. G. Maidanik, "Power dissipation in a sprung mass attached to a master structure," J. Acoust. Soc. Am. 98, 3527-3533 (1995).
13. G. Maidanik and J. Dickey, "An impulse response function for a fuzzy structure," J. Acoust. Soc. Am. 97, 1460-1471 (1995).

INITIAL DISTRIBUTION

Copies		Copies		
4	NAVSEA 03T2 2 Taddeo 1 Becker 1 Biancardi	1	Catholic Uni. of Am. Eng. Dept. McCoy	
5	ONR/ONT 1 334 Tucker 1 334 Radlinski 1 334 Vogelsong 1 334 Main 1 Library	2	Boston University 1 Pierce 1 Barbone	
4	NRL 1 5130 Bucaro 1 5130 Williams 1 5130 Photiadis 1 Library	2	Penn State University Koopman	
		2	Virginia Tech 1 Knight 1 Fuller	
				Copies Code Name
		1	011	Corrado
4	NUWC/NPT 1 Sandman 1 Harari 1 3332 Lee 1 Library	2	0112	Douglas Halsall
		1	20	
		1	2040	Everstine
2	DTIC	1	2042	Hambric
2	Johns Hopkins University 1 Green 1 Dickey	1	70	Covich
1	Applied Physics Lab Johns Hopkins University Library	3	7015	Fisher Hamly Vendittis
		3	7030	
1	ARL/Penn State University Burroughs	1	7200	Hwang
1	Cambridge Collaborative Manning	4	7250	Shang Maga Vasudevan Carroll
1	Cambridge Acoustical Associate Garrelick	1	726	Szilagyi
1	J. G. Engineering Research Greenspan	1	842	Graesser
		2	3421	(TIC-Carderock)
2	MIT 1 Dyer 1 Manning			