

Management and Maintenance Manual
The Old Hospital Complex
Fort Carson, Colorado
(5EP1778)



by

James Schneck

Midwest Archeological Center
National Park Service
Lincoln, Nebraska

Prepared for and funded by:
The Directorate of Environmental Compliance and Management
Headquarters, Fort Carson
Fort Carson, Colorado
February 1997

DISTRIBUTION STATEMENT B

Approved for public release
Distribution Unlimited



19970515 097

REPORT DOCUMENTATION PAGE

Form Approved
OMB No. 0704-0188

Public reporting burden for this collection of information is estimated to average 1 hour per response, including the time for reviewing instructions, searching existing data sources, gathering and maintaining the data needed, and completing and reviewing the collection of information. Send comments regarding this burden estimate or any other aspect of this collection of information, including suggestions for reducing this burden, to Washington Headquarters Services, Directorate for Information Operations and Reports, 1215 Jefferson Davis Highway, Suite 1204, Arlington, VA 22202-4302, and to the Office of Management and Budget, Paperwork Reduction Project (0704-0188), Washington, DC 20503.

1. AGENCY USE ONLY (Leave blank)		2. REPORT DATE February, 1997		3. REPORT TYPE AND DATES COVERED Final	
4. TITLE AND SUBTITLE Management and Maintenance Manual The Old Hospital Complex Fort Carson, Colorado (5EP1778)				5. FUNDING NUMBERS	
6. AUTHOR(S) James Schneck					
7. PERFORMING ORGANIZATION NAME(S) AND ADDRESS(ES) Midwest Archeological Center National Park Service Room 474 Federal Building 100 Centennial Mall North Lincoln, NE 68508				8. PERFORMING ORGANIZATION REPORT NUMBER N/A	
9. SPONSORING/MONITORING AGENCY NAME(S) AND ADDRESS(ES) Environmental Compliance and Management Headquarters, Fort Carson Fort Carson, Colorado				10. SPONSORING/MONITORING AGENCY REPORT NUMBER N/A	
11. SUPPLEMENTARY NOTES					
12a. DISTRIBUTION / AVAILABILITY STATEMENT Available				12b. DISTRIBUTION CODE	
13. ABSTRACT (Maximum 200 words) This manual was written to assist in the maintenance and management of the historic Old Hospital Complex (5EP1778) at Fort Carson, Colorado. The report outlines the character-defining features of the complex, defines management guidelines for the protection and maintenance, and general specifications for maintenance and repair. It includes a cyclic maintenance checklist, schedule, and record, as well as a list of the architectural drawings on file for the complex at Fort Carson. In addition it includes a copy of the Secretary of the Interior's Standards for Rehabilitation and Illustrated Guidelines for Rehabilitating Historic Buildings, and relevant Preservation Tech notes and Preservation Briefs.					
14. SUBJECT TERMS Fort Carson, Old Hospital Complex, maintenance on historic structures				15. NUMBER OF PAGES	
17. SECURITY CLASSIFICATION OF REPORT Available				16. PRICE CODE	
18. SECURITY CLASSIFICATION OF THIS PAGE Available		19. SECURITY CLASSIFICATION OF ABSTRACT Available		20. LIMITATION OF ABSTRACT None UL	

GENERAL INSTRUCTIONS FOR COMPLETING SF 298

The Report Documentation Page (RDP) is used in announcing and cataloging reports. It is important that this information be consistent with the rest of the report, particularly the cover and title page. Instructions for filling in each block of the form follow. It is important to *stay within the lines* to meet *optical scanning requirements*.

Block 1. Agency Use Only (Leave blank).

Block 2. Report Date. Full publication date including day, month, and year, if available (e.g. 1 Jan 88). Must cite at least the year.

Block 3. Type of Report and Dates Covered. State whether report is interim, final, etc. If applicable, enter inclusive report dates (e.g. 10 Jun 87 - 30 Jun 88).

Block 4. Title and Subtitle. A title is taken from the part of the report that provides the most meaningful and complete information. When a report is prepared in more than one volume, repeat the primary title, add volume number, and include subtitle for the specific volume. On classified documents enter the title classification in parentheses.

Block 5. Funding Numbers. To include contract and grant numbers; may include program element number(s), project number(s), task number(s), and work unit number(s). Use the following labels:

C - Contract	PR - Project
G - Grant	TA - Task
PE - Program Element	WU - Work Unit Accession No.

Block 6. Author(s). Name(s) of person(s) responsible for writing the report, performing the research, or credited with the content of the report. If editor or compiler, this should follow the name(s).

Block 7. Performing Organization Name(s) and Address(es). Self-explanatory.

Block 8. Performing Organization Report Number. Enter the unique alphanumeric report number(s) assigned by the organization performing the report.

Block 9. Sponsoring/Monitoring Agency Name(s) and Address(es). Self-explanatory.

Block 10. Sponsoring/Monitoring Agency Report Number. (If known)

Block 11. Supplementary Notes. Enter information not included elsewhere such as: Prepared in cooperation with...; Trans. of...; To be published in.... When a report is revised, include a statement whether the new report supersedes or supplements the older report.

Block 12a. Distribution/Availability Statement. Denotes public availability or limitations. Cite any availability to the public. Enter additional limitations or special markings in all capitals (e.g. NOFORN, REL, ITAR).

DOD - See DoDD 5230.24, "Distribution Statements on Technical Documents."

DOE - See authorities.

NASA - See Handbook NHB 2200.2.

NTIS - Leave blank.

Block 12b. Distribution Code.

DOD - Leave blank.

DOE - Enter DOE distribution categories from the Standard Distribution for Unclassified Scientific and Technical Reports.

NASA - Leave blank.

NTIS - Leave blank.

Block 13. Abstract. Include a brief (*Maximum 200 words*) factual summary of the most significant information contained in the report.

Block 14. Subject Terms. Keywords or phrases identifying major subjects in the report.

Block 15. Number of Pages. Enter the total number of pages.

Block 16. Price Code. Enter appropriate price code (*NTIS only*).

Blocks 17. - 19. Security Classifications. Self-explanatory. Enter U.S. Security Classification in accordance with U.S. Security Regulations (i.e., UNCLASSIFIED). If form contains classified information, stamp classification on the top and bottom of the page.

Block 20. Limitation of Abstract. This block must be completed to assign a limitation to the abstract. Enter either UL (unlimited) or SAR (same as report). An entry in this block is necessary if the abstract is to be limited. If blank, the abstract is assumed to be unlimited.

Management and Maintenance Manual

The Old Hospital Complex,

Fort Carson, Colorado

(5EP1778)

By

James Schneck

Midwest Archeological Center
National Park Service
Lincoln, Nebraska

Prepared for and funded by:

Directorate of Environmental Compliance and Management
Headquarters, Fort Carson
Fort Carson, Colorado

February 1997

INDEX TO SECTIONS
MANAGEMENT AND MAINTENANCE MANUAL
OLD HOSPITAL COMPLEX, FORT CARSON

Management and Maintenance Plan for Old Hospital Buildings S6220 to S6236 and S6238 to S6290.
 Character-Defining Features
 Management Guidelines
 General Specifications

Cyclic Maintenance Checklist

Cyclic Maintenance Schedule

Cyclic Management Record

Reference Materials Architectural Drawing Index

The Secretary of the Interior's Standards for Rehabilitation and Illustrated Guidelines for Rehabilitating
Historic Buildings

Preservation Tech Notes

Preservation Briefs

Source List for Additional Information

MANAGEMENT AND MAINTENANCE PLAN,
OLD HOSPITAL COMPLEX, FORT CARSON

This Management and Maintenance Plan serves 800 Series building types:

CCH-3.10	Central Service & Occupational Therapy Clinic Building
CSA-362	Nurses' Quarters
HAB-1	Administration Building
HAR-1	Administration and Receiving
HC-1	Clinic
HCW-88	Combination Ward
HG-8	Garage
HMDB-133	Medical Detachment Barracks
HMDM-460	Medical Detachment Mess and Kitchen
HMDR-1	Hospital Medical Detachment Recreation
HMO-1	Morgue
HNM-220	Nurses' Mess and Kitchen
HNPW-82	Neuropsychiatric Ward
HNQ-31/	Nurses' or Officers' Quarters
HOQ-31	"
HNQ-63/	Hospital Nurses' or Officers' Quarters
HOQ-63/	"
HOQM-63/	"
HNQM-63/	"
HNQMS-63/	"
HOQM-74/	"
HNQM-74/	"
HNQS-74/	"
HOQ-85/	"
HNQ-85/	"
HPE-1	Hospital Post Exchange
HPM-600	Patients' Mess and Kitchen
HPRB-1	Hospital Patients' Recreation Building
HPS-1	Paint Shop
HSH-1	Shop
HSP-8	Steam Plant
HSPW-76	Special Ward
HST-1	Storehouse
HST-2	Storehouse
HSW-98*	Standard Ward
HSXR-1	Surgery and X-Ray, Hospital Clinic
HUS-1	Utility Shop
PEA386/	Radio Broadcasting Station
PEA392	"

* All work done at Building S6237 shall follow the *Management and Maintenance Plan, Building S6237*.

OVERVIEW

The Old Hospital Complex (OHC) is culturally significant within American history for its association with the United States' victory in World War II. This Management and Maintenance Plan has been prepared to assist users in identifying significant exterior features for all 800 Series building types at the OHC.

This Management and Maintenance Plan format is based upon the Secretary of the Interior's Standards and Guidelines for Restoring Historic Buildings. A summary of general requirements relevant to all aspects of building maintenance introduces the plan. These general requirements are followed by lists of character-defining exterior features for each building; guidelines for their restoration, rehabilitation, repair, or replacement; and general specifications for new materials. The remaining original building fabric, the original 800 Series US Army Corps of Engineers plans, and records of modifications were used to approximate, as closely as possible, the characteristics of the Old Hospital Complex buildings during World War II.

The Management and Maintenance Plan is accompanied by sample Cyclic Maintenance Schedules, Cyclic Maintenance Checklists, and Cyclic Maintenance Records. Caring for historic buildings is an ongoing and dynamic process of observation and assessment, planning, treatment, and evaluation. The Management and Maintenance Plan must therefore be flexible to accommodate new and changing building requirements, methods of management, and technologies. The establishment of the Maintenance Schedule, Checklist, and Record is necessary to insure consistent and informed care of buildings over time. This management guideline and project specifications should be modified with the results of additional documentary research regarding original historic elements or features of the OHC.

Recommended cycle of care:

- | | | |
|--------------------|---|--|
| observe and assess | - | be vigilant for problems or potential problems |
| plan | - | refer to the building or complex Management Record for treatment alternatives |
| treat | - | use the Secretary's Guidelines discussed in this Plan |
| evaluate | - | record action and success in Management Records, in Real Property Records, and in the Historical Repair Work List. |

BRIEF HISTORY OF MODIFICATIONS AT THE OLD HOSPITAL COMPLEX

The OHC was constructed in 1942 and 1943 as part of America's preparation for entry into World War II. Thousands of men and women, laboring around the clock, participated in construction. Architectural drawings were based upon the 800 Series of standardized building plans developed by the War Department's Quartermaster General's Office.

Modifications to the complex began almost immediately after it was completed. Heavy numbers of patients forced the conversion of some barracks buildings to hospital and convalescent hospital

facilities. Several major renovations and additions occurred in 1945, including new construction of, or at, Buildings S6225, S6226, S6232, S6260, and S6261.

After serving as a separation center for returning World War II veterans, many hospital personnel quarters and some wards were converted in 1946 to temporary living quarters for military personnel. At this time the administration building became post headquarters, and air conditioning was installed in several buildings to accommodate the installation of new hospital equipment. The complex played a traditional role in the Korean War during the early 1950s, serving as a 1,500-bed hospital and as a separation center for personnel in transition.

Just prior to Camp Carson becoming a permanent installation in 1954, most original exterior wood entrances were replaced with cast-in-place or pre-cast concrete stairs. New roofing was installed on all OHC buildings in 1960. New flooring was installed in most of the complex in 1966.

During the 1970s the Army began an intensive building-modification program aimed at increasing energy efficiency and removing hazardous materials. Some asbestos-laden Masonite wallboard and pipe insulation has been removed. Asbestos-laden dirt floors within the corridor crawlspaces were sealed with Gunite. Some lead-based paint has also been removed.

In the mid-1970s, the Army began a program of revitalization. Attics were insulated and additional buildings were air-conditioned. Many buildings were rewired and incandescent lighting was replaced with fluorescent lighting. The original one-zone heating systems were reconfigured in many buildings to accommodate two or four zones.

With the opening of the replacement Evans Army Hospital in 1986, many of the OHC buildings were converted to office space or vacated. These conversions primarily involved the remodeling of interior spaces through the installing of carpeting, wall paneling, and acoustical ceiling tile, fresh paint, and the replacing of many original doors. At this time most original windows in the complex were replaced with single-pane aluminum sashes. The new windows were ineffective and in 1987-1988 were replaced, this time with Sugar Creek brand aluminum sash windows. At this time sloped roofs were installed over the original flat roofs of many of the corridors. Many screened convalescent porches were demolished in the mid 1980s. Several modifications identified in Connor and Schneck (1996) are undocumented in military records. For example, at some point many or all original foundation vents were removed or covered with pressed sheet metal vents screwed to the exterior surface of the building walls.

GENERAL REQUIREMENTS FOR MAINTENANCE

The Technical Manual for Historic Preservation Maintenance Procedures (Department of the Army 1977) identifies several considerations for the maintenance of historic buildings.

The cultural and historic value of a building is intimately connected with its original fabric—largely the original materials present and the original building techniques that survive.

A building worthy of conserving must be given supervision and maintenance to keep it in good repair. Historic Building Cyclic Maintenance Schedules and Checklists, found in this manual, should be maintained for every building. Project specifications should require all work proposals to be reviewed and approved by personnel familiar with

these guidelines, and all new work to conform to original 800 Series plans and specifications unless noted. All work should be carried out by competent personnel trained both in the care of historic features and in the proper application of new or replacement materials.

Maintenance measures should be evaluated and chosen which minimize adverse effects on the historical aspects of the structure. Current source material for the treatment of historic military buildings is included in the Source List. New processes and products should be applied according to manufacturer's specifications and should be tested on less visible surfaces or non-historic buildings before application on a widespread basis. The short-term benefits of proposed actions should always be compared against the long-term goal of preserving the historic materials.

Maintenance is not just cleaning and painting but also the repair or replacement of worn out parts and the correction of the causes of deterioration. Reference should be made to the Historic Building Cyclic Management Record for previous methods of care prior to any action. Established and successful methods should be used whenever possible.

Modern materials and methods are alien to an old building and should be avoided. If original material is missing, replaced with non-original material, or damaged beyond repair, every effort shall be made to replace the damaged material using salvage from adjacent World War II era 800 Series buildings to be demolished. Historic materials may also be relocated from less conspicuous areas of a building to areas more visible to public view.

The aesthetic qualities and architectural elements of a building are an integral part of the structure and should be preserved. These character-defining features should be maintained and preserved whenever possible. Functionality is the dominant characteristic of all 800 Series military buildings. The character-defining features of the Hospital Complexes buildings are their low, symmetrical appearance, a simple and repetitive pattern of door and window openings, and the intersection of walkway corridors at the buildings' midpoints.

Documentation is essential both before and after maintenance work in order to preserve a true picture of the building for future generations and provide data for maintenance projects. All work should be documented on the Historical Repair Work List (listed in the Directorate of Public Works Base Operations Division blanket contract) and Historic Building Cyclic Management Record, found in this manual.

SUMMARY OF THE SECRETARY OF THE INTERIOR'S STANDARDS FOR RESTORATION

The Secretary of the Interior's Standards and Guidelines for Restoring Historic Buildings are listed in their entirety in this manual. The ten standards for restoration, when applied to the exteriors of the OHC buildings, require that: the buildings be reutilized in a manner that requires minimal alteration of

their exterior appearance; that the buildings' original exterior materials, appearance, construction, and distinctive detailing be restored as closely as possible; that maintenance, repair, or replacement be carried out in such a way that the work is outwardly indistinguishable from the original yet clearly identifiable as modern work upon close inspection; that demolition not destroy the historic materials or character of the surrounding buildings' exteriors; that new construction be compatible with the massing, size, scale, and architectural features of the existing buildings; and that care be taken so that custodial or routine maintenance work not damage the exteriors of the buildings.

All building elements known to be original to the building should be preserved if in excellent and original condition. If altered, they should be sensitively restored to original condition. If restoration is not feasible, the elements should be replaced with a similar element that appears historic and maintains the visual continuity of the building. If missing, elements may be reconstructed but should appear as if original.

Character-Defining Features, Management Guidelines,
and General Specifications

Notes for Management Guidelines:

Protection and Maintenance refers to the protection and maintenance of original material.

Repair refers to the repair of original material.

Replacement refers to the replacement of heavily damaged, missing, and non-original materials.

CONCRETE: Character-Defining Features

Foundation

- ◆ Smooth, painted foundation surface with visible impressions of wood forms made of rough-sawn boards
- ◆ Foundation profile flush with cinder block wall
- ◆ Foundation vents at regular intervals
- ◆ Crawlspace hatches at gable ends
- ◆ Poured, raised stair piers
- ◆ Poured loading dock foundation, stairs, and platforms

CONCRETE Management Guidelines

Recommended

Protection and Maintenance

Provide proper drainage so water does not stand or accumulate.

Clean walls only when necessary to halt deterioration or remove heavy soiling. Chemical cleaning, if utilized, should be conducted by experienced professionals.

Tests should be conducted to determine the gentlest effective cleaning method possible, e.g., hand-washing or low- to medium-pressure water cleaning. Tests should be observed over a sufficient period of time so that both the immediate and the long-range effects are known.

Remove damaged, deteriorated paint only to the next sound layer. Remove hazardous paint completely. Paint removal methods shall utilize the gentlest means possible. The texture of the concrete should be preserved to the greatest extent possible.

Apply specification-approved primer and paint following proper surface preparation and product instructions.

Repair

Repair any cracks in concrete by sealing with specification-approved sealant.*

Patch damaged sections with in-kind material finished to match existing.*

Replacement

Repair damaged concrete too deteriorated to patch by cutting damaged material back to remove the source of deterioration (often corrosion of metal reinforcement bars). New patch must be applied with in-kind material finished to match existing.*

Replace sections too deteriorated to repair using materials compatible with the original materials.**

Not Recommended

Protection and Maintenance

Applying non-specified paint or other coatings such as stucco or insulation.

Introducing new or non-specified brands of paint, colors, or methods of application.

Cleaning surfaces not heavily soiled.

Cleaning without testing or without sufficient time for testing results to be of value.

Sandblasting using dry or wet grit or other abrasive agent, high-pressure waterblasting, or caustic solutions. These methods of cleaning or paint removal may permanently erode the wall surface and accelerate deterioration.

Wet-cleaning when there is any possibility of freezing temperatures.

Repair

Replacing or rebuilding a major portion of foundation wall that could be repaired.

Patching concrete without removing the source of deterioration.

Patching with substitute material that is physically or chemically incompatible with the original concrete.

* Work shall not be initiated without approval of the Colorado Historic Preservation Office (303) 866-3398.

** Work shall not be initiated without approval of the Directorate of Environmental Compliance and Management (719) 526-4652.

General Specifications

Replacement concrete should be mixed to ASTM standards that match the hardness, composition, and appearance of the original concrete.

Paint should be a vapor-permeable, cement-based mixture capable of adhering to the stripped concrete surface, with color and finish to match wall surface.

MASONRY: Character-Defining Features

- ◆ Visible pattern of cinder block and flush tooled mortar
- ◆ Sharp building corners
- ◆ Rough texture of the cinder block face
- ◆ Wall profile flush with foundation wall
- ◆ Symmetrical pattern of original fenestration

MASONRY Management Guidelines

Recommended

Protection and Maintenance

Protect and maintain masonry elements as per management guidelines for Concrete.

Prior to repainting, at least one cinder block from a building to be demolished should be carefully stripped to its first layer of paint, then documented. The texture of this block and the characteristics of its original layer of paint, if visible, should be replicated as closely as possible on all preserved buildings. The block should be archived to facilitate future research.

Repair

Repoint disintegrated mortar, cracks in mortar joints, or loose bricks. Remove deteriorated mortar by stiff brush or hand chisel (to minimum depth of 3/4"), or by the gentlest means possible.*

- Duplicate old mortar in strength, composition, color and texture.
- Duplicate old mortar joints in width and joint profile.

Replace deteriorated or damaged cinder blocks by carefully patching, piecing-in, or otherwise reinforcing the masonry, using recognized preservation methods. Replace with salvage or in-kind material painted to match existing. Replacement work should be permanently dated in an unobtrusive location.*

Not Recommended

Protection and Maintenance

Replacing or rebuilding any portion of the masonry wall that could be repaired.

Applying non-specified paint or other coatings such as stucco or insulation.

Introducing new or non-specified brands of paint, colors, or methods of application.

Cleaning masonry surfaces not heavily soiled.

Cleaning without testing or without sufficient time for testing results to be of value.

Sandblasting using dry or wet grit or other abrasive agent, high-pressure waterblasting, or caustic solutions. These methods of cleaning or paint removal may permanently erode the wall surface and accelerate deterioration.

Wet-cleaning when there is any possibility of freezing temperatures.

Repair

Replacing or rebuilding any damaged portion of the wall that could be repaired.

Removing non-deteriorated mortar from sound joints.

Repointing with mortar that is stronger than or inconsistent in porosity and texture with existing mortar.

Repointing with a synthetic caulking compound.

Changing the original width or joint profile when repointing.

Patching deteriorated masonry without removing or addressing any external sources of the deterioration, such as water dripping from eaves.

Patching with substitute materials that are physically or chemically incompatible with the original materials.

Recommended

Replacement

Replace major wall sections too deteriorated to repair using materials compatible with the original materials.**

Not Recommended

Replacement

Removing an original masonry feature that is unrepairable and not replacing it, or failing to label the new work.

* Work shall not be initiated without approval of the Colorado Historic Preservation Office (303) 866-3398.

** Work shall not be initiated without approval of the Directorate of Environmental Compliance and Management (719) 526-4652.

General Specifications

The building's cinder block walls are both strong character-defining features and vital components of the building's structural integrity. Contract specifications should require proof of experience in dealing with historic masonry. Work should be carefully overseen by professionals trained in the preservation of historic masonry.

Repointing is necessary to prevent moisture penetration of deteriorated joints. Mortar used in repointing should always be softer than the adjacent brick. Mortars with high Portland cement content should not be used. Replacement mortar should be mixed to an appropriate ASTM standard that matches the composition and appearance of the original mortar and does not exceed its hardness or the hardness of the surrounding cinder block.

Replacing missing or deteriorated block is necessary to prevent moisture penetration or animal infestation. Replacement block should always be softer than the adjacent block. Block should consist of ASTM standard cinder, coal ash, or coke block extruded to match original block in size and texture and not exceeding the hardness of the surrounding cinder block.

Paint should be a vapor-permeable, alkali-resistant, cement-based mixture capable of adhering to the deeply textured surface of the stripped or replaced cinder block and mortar. A compatible fill coat may be applied beneath the finish coat to smooth large voids.

Exterior surfaces should be painted to match a Munsell Color Chart color of 'pale yellow' (2.5Y 7/4). Glidden's formula for this color is

BLK 1 P 18 YOX 3 P 51 OXR 0 P 55

Y-3600 Spred Dura Flat House Paint

Sherwin Williams' formula for this color is

BAC	COLORANT	OZ	32	64	128
Y3	Deep Gold	4	31	--	1
R2	Maroon	--	2	1	1
N1	Raw Umber	4	8	1	1
W1	White	--	21	--	1

with one gallon of Midtone Base A

A-100 Latex Flat House and Trim Paint

METALS: Character-Defining Features

- ◆ Regularly spaced foundation vents surrounding building
- ◆ Rectangular foundation vents 8" by 12" with two columns of flutes
- ◆ Manhole covers on loading docks
- ◆ Vent stacks (as per 800 Series plans)
- ◆ 1 1/2" diameter pipe railings at exterior basement entrances

METALS

Management Guidelines

Recommended

Protection and Maintenance

Clean paint and corrosion using the gentlest means possible: scraping, sanding, or rubbing with a cloth imbued with mineral spirits.

Apply specification-approved primer and paint following proper surface preparation and product instructions.

Repair

Reshape bent elements.

Resecure any loose vents.

Existing non-original anchor holes on walls' exterior surfaces should be patched.

Replacement

Replace damaged features, missing elements, or non-original vents with salvage or in-kind material to match original. Replacement material should be permanently dated in an inconspicuous location.**

Not Recommended

Protection and Maintenance

Failing to identify, evaluate, and treat corrosion, or painting over it.

Using harsh cleaning methods, such as grit, sand, or waterblasting in order to strip or clean material.

Introducing new or non-specified brands of paint, colors, or methods of application.

Repair

Failing to immediately apply protective coating to exposed surfaces or otherwise allowing corrosion to form.

Replacement

Replacing original metal features that could be reutilized.

Using a replacement material that does not convey the visual appearance of the surviving, original material.

** Work shall not be initiated without approval of the Directorate of Environmental Compliance and Management (719) 526-4652.

General Specifications

Replacement vents should be constructed of first-quality metal. The vents' overall dimensions and appearance should match that of the original vents. Original grates have two vertical columns of flutes. The flutes are 3/8" thick and sit 3/4" on center. The grates are backed by inconspicuous metal insect screens.

Vents should be repainted with one coat of primer for metal and at least two finish coats of exterior grade paint; color and finish to match wall surface.

Manhole covers should be painted with one coat of primer for metal and at least two finish coats of exterior grade enamel paint.

Functional replacement vent stacks should consist of appropriate units that match original in appearance. Dummy stacks should match original in appearance.

WOOD AND PLASTICS: Character-Defining Features

Exterior

- ◆ Dimensioned wood railings on entrance stairs
- ◆ Dimensioned wood railings and muntins on screened porch openings
- ◆ Dimensioned wood stairs (at original first-floor entrances)
- ◆ Dimensioned wood cornice bands and returns on gable ends
- ◆ Dimensioned wood vents at gable peaks
- ◆ Dimensioned wood dormer vents on roof slopes
- ◆ Dimensioned wood lap siding on window spandrels

WOOD AND PLASTICS Management Guidelines

Recommended

Protection and Maintenance

Remove damaged or deteriorated paint only to the next sound layer using the gentlest means possible (handscraper, wire brush, or sand paper), then repainting. Stripping methods including hot air guns, heat plates, and chemical or dip stripping should be employed with great care, and only as a supplement to handscrapping, brushing, and sanding.

Apply specification-approved primer and paint following proper surface preparation and product instructions.

Inspect regularly for wood that is excessively or continually moist and for evidence of insect infestation and fungal rot.

Address evidence of moisture infiltration and infestation as soon as possible.

Use only hot-dipped, zinc-coated nails, bolts, and hardware for use on treated wood.

Countersink and putty all new, exposed nails and screws according to general specifications in Caulk and Sealants.

Repair

Fill moderate-sized holes and check cracks with putty or epoxy filler. Repair should be applied as per general specifications for Caulk and Sealants.

Repair fragile original wood using well-tested consolidants when appropriate. Repairs should be physically, visually, and chemically compatible and identifiable upon close inspection.*

Replacement

Replace deteriorated or damaged wood by carefully patching, piecing-in, or otherwise reinforcing the wood using recognized preservation methods. Replacement work should be permanently dated in an unobtrusive location.*

Not Recommended

Protection and Maintenance

Replacing, rebuilding, or altering any original wood features that could be preserved or consolidated.

Introducing new or non-specified brands of paint, colors, or methods of application.

Failing to identify, evaluate, and treat the causes of wood deterioration, including faulty flashing, leaking gutters, cracks and holes in spandrel siding, deteriorated caulking in joints and seams, plant material growing too close to wood surfaces, or insect or fungus infestation.

Using chemical preservatives (such as creosote) which can change the appearance of wood features.

Using destructive paint removal methods such as propane or butane torches, sandblasting, or waterblasting. These methods can irreversibly damage historic woodwork.

Using thermal devices improperly when removing paint so that historic woodwork is scorched or damaged.

Failing to neutralize wood thoroughly after using chemicals so that new paint does not adhere.

Allowing detachable wood features, like doors, to soak too long in a caustic solution so that the wood grain is raised and the surface roughened.

Repair

Removing or replacing original wood that could be stabilized and conserved, or repaired with limited replacement of deteriorated or missing parts.

Using substitute materials that are physically, visually, or chemically incompatible with the original materials.

Replacement

Removing an original wood feature that is unrepairable and not replacing it, or failing to label the new work.

* Work shall not be initiated without the approval of the Colorado Historic Preservation Office (303) 866-3398.

General Specifications

Replacement exterior woodwork should be first-quality, pressure-treated exterior-grade wood. Replacement interior finished millwork should be first-quality interior-grade wood. Finger joints are acceptable only on those elements to be painted.

Woodwork, if chemically stripped, should be thoroughly removed or neutralized before the reapplication of finishes. Exterior woodwork should be primed with at least one coat of exterior-grade primer and finished with at least three coats of paint; color and finish to match wall color. Original finishes should be recreated as documentary analysis suggests or as called for in original 800 Series plans and specifications.

**THERMAL AND MOISTURE PROTECTION:
Character-Defining Features**

Roofing

- ◆ Moderate-pitch gable roofs, flat roof
@ HSP-8
- ◆ Wood eyebrow dormer vents
- ◆ Slightly overhung, boxed eaves
- ◆ Gutterless eaves
- ◆ Cornice band at eaveline, with returns
on gable sides
- ◆ Tabbed, mineral-surfaced asphalt
shingles

THERMAL AND MOISTURE PROTECTION Management Guidelines

Recommended

ROOFING

Protection and Maintenance

Maintain proper attic ventilation by keeping vents clean and clear.

Provide adequate anchorage for roofing material to guard against wind damage and moisture penetration.

Repair

Repair extensively deteriorated sheathing, rafter, or truss material, and dormer vents with the limited use of replacement material. All work should be permanently dated in an inconspicuous location.*

Wet sheathing, caused by a failure within the roofing system, may be reutilized after drying.

Replacement

Replace roofing material with specification-approved shingles. Replacement may include the use of additional waterproofing beneath the shingles. The appearance and construction of replacement roof material should match that of the original. Replacement material should be permanently dated in an inconspicuous location.*

THERMAL INSULATION

Install thermal insulation in attics and crawlspaces.

Install insulating material on the inside of masonry walls where interior doors and window sills and surrounds are preserved.

Not Recommended

ROOFING

Protection and Maintenance

Failing to maintain proper ventilation.

Using roof fasteners susceptible to corrosion.

Failing to immediately trace and address leaks at their source.

Repair

Replacing dormer vents or other features when the repair of materials or limited replacement of deteriorated or missing parts is appropriate.

Removing unrepairable dormer vents or other features and not replacing them, or failing to label the new work.

THERMAL INSULATION

Applying thermal insulation with a high moisture content in wall cavities.

Installing wall insulation without considering its visual and physical effect on character defining features.

Recommended

CAULK AND SEALANTS

Install caulk at all exterior window and door jambs. Bead should be flush with surface, unless required for drainage.**

Install sealant around any original remaining window sashes.**

Install sealant around any original or new roof protrusions.**

Not Recommended

CAULK AND SEALANTS

Applying caulk or sealant that is visually, physically, or chemically incompatible with the surrounding building materials.

Installing caulk or sealant without considering its visual and physical effect on character defining features.

* Work shall not be initiated without approval of the Colorado Historic Preservation Office (303) 866-3398.

** Work shall not be initiated without approval of the Directorate of Environmental Compliance and Management (719) 526-4652.

General Specifications

ROOFING

Replacement roofing should consist of tabbed, mineral-surfaced asphalt shingles. Waterproofing should be a reversible application compatible with the existing sub-sheathing and the new shingle roofing.

Replacement sheathing and structural members should consist of first quality pressure-treated exterior grade wood.

THERMAL INSULATION

Insulation should be able to be removed without damage or significant alteration of the original structure.

Insulation should be vapor-permeable.

CAULK AND SEALANTS

The applications of caulk and sealant should be reversible. Caulk and liquid sealants at window and door jambs and other openings should be flexible when cured, inconspicuous, and color-matched to surrounding surfaces, or primed and painted, according to manufacturer's instructions, to match surrounding surfaces.

DOORS AND WINDOWS: Character-Defining Features

Doors

Original Entrance-and-Exit

- ◆ Basic configuration of five horizontal panels (varies with glazing)
- ◆ Panels are flat, not raised
- ◆ Transoms
 - Wood frame
 - Fixed, clear lights
- ◆ Exterior screen doors
- ◆ Simple metal hardware
 - Two or three hinges per door
 - Hinges are five-knuckle butt type, mortised into door, not into frame
 - Ball-tip hinge pins
 - Three-hole leaves, unornamented
 - Mortised locksets with keyed deadbolts
 - Plain-set rectangular plates, with beveled edges
 - Hollow, round metal doorknobs above a simple keyhole
 - Mortised metal strike plates

*Access Doors**

- ◆ Paneled wood access door
- ◆ Panels are flush, not raised
- ◆ Hinged on the side
- ◆ Equipped with lock

*Vehicular/Loading Dock Doors**

- ◆ Diagonal wood batten construction
- ◆ Diagonal boards braced on the exterior
- ◆ Hinged or sliding operation
- ◆ Equipped with locks

Windows

Original

- ◆ Regular and symmetrical appearance
- ◆ Windows placed in simple, punched openings
- ◆ Wood frame
- ◆ Double-hung
- ◆ Multi-lights (panes) in each sash
 - Obscured glass in lower sashes of bathroom windows
 - Clear glass in all other sashes
- ◆ Simple wood surrounds and flat wood sills inside
- ◆ Shutterless exteriors
- ◆ Curtains or shades
- ◆ Hardware
 - Metal thumb-latches
 - Spring-pinned lower sashes
- ◆ Hinged wire window screens
(at operable windows)
 - Wood rails and stiles
 - Wire-guard insect screens
 - Two metal hangers per screen

- ◆ Transoms
 - Wood frame
 - Fixed sash
 - Clear lights

- ◆ Steam Plant Windows (Type HSP-8)
 - Regular and symmetrical appearance
 - Windows placed in simple, punched openings
 - Wood frame
 - Double-hung, fixed and pivoting
 - Multi-lights in each sash
 - Clear glass
 - Simple wood surrounds and flat wood sills inside
 - Shutterless exteriors

DOORS AND WINDOWS Management Guidelines

Recommended

DOORS

Protection and Maintenance

Regular cleaning and removal of loose paint prior to reapplication with specification-approved finish.

Install and maintain caulk and weatherstrip on exterior units to maximize energy efficiency.

Periodic lubrication of operable hinges and hardware to extend life and inhibit corrosion.

Repair

Repair missing hardware or doors with salvage or in-kind material.

Replacement

Restore, repair and reutilize original remaining material, including wood frames, surrounds, and sills, as much as is practicable.

Replace non-original doors and hardware with salvage or in-kind, specification-approved units painted to match original. Replacement units should be permanently dated in an inconspicuous location.**

Not Recommended

DOORS

Protection and Maintenance

Applying excessive layers of paint to hardware.

Introducing new or non-specified brands of paint, colors, or methods of application.

Replacement

Using a substitute unit that is physically incompatible with the character of the historic, original doors.

Recommended

WINDOWS

Protection and Maintenance of Restoration Units

Regular cleaning and removal of loose paint prior to reapplication with specification-approved finish.

Install and maintain caulk and weatherstrip to maximize energy efficiency.

Exterior storm windows, if installed, must not damage or obscure original or restoration windows and frames. Interior storm windows, if installed, should include air-tight gaskets, ventilating holes, and/or removable clips to ensure proper maintenance and to avoid condensation on original or restoration windows.**

Replacement

Replace non-original windows with salvage or in-kind, specification-approved units that match originals in size, operation, glazing pattern, and muntin profile. Replacement units should be permanently dated in an inconspicuous location.**

Restore, repair, and reuse original remaining material, including wood frames, surrounds, sills, and screens, as much as is practicable.

Remove, document and archive one example of the existing modern vinyl-clad windows to facilitate future research.**

Not Recommended

WINDOWS

Replacement

Using a substitute unit that is physically incompatible with the character of the historic, original windows.

Using exterior shading devices.

Using false-muntined windows.

Introducing new or non-specified brands of paint, colors, or methods of application.

Installing interior storm windows if they allow moisture to accumulate and damage the window.

Installing exterior storm windows that obscure the original or restored windows and frames.

Installing replacement window and transom units with fixed thermal glazing or permitting windows and transoms to remain inoperable rather than utilizing them for their energy conserving potential.

** Work shall not be initiated without approval of the Directorate of Environmental Compliance and Management (719) 526-4652.

General Specifications

DOORS

Replacement exterior doors should be constructed of exterior grade wood. Replacement doors should match as closely as possible the size, material, construction, and rail, stile, and panel profiles of the original doors. Fire-rated exterior doors should be visually similar to the original wood doors.

WINDOWS

Replacement windows should match as closely as possible the original window's function, size, material, number of lights, and muntin profile.

SPECIAL CONSTRUCTION: Character-Defining Features*

Original Sun Porches

- ◆ Two-story construction
- ◆ Flat roofs
- ◆ Full-height screened openings
- ◆ Simple wood railings

Original Sun Rooms

- ◆ One- and two-story construction
- ◆ Flat roofs
- ◆ Full-height window openings
- ◆ Wood spandrels between windows on full-height openings

Original Stoops

- ◆ Wood steps and structural members
- ◆ Simple dimension wood railings
- ◆ Stoop supported by a single concrete step or foundation member
 - Smooth surface
 - Rectangular in shape
 - Slab exposed to seven inches above grade

Original Ambulance Drop-Offs

- ◆ Wood steps and platform
- ◆ Poured-concrete piers
 - Smooth surface
 - Rectangular in shape
- ◆ Wood shed roof over steps and platform

Original Loading Docks

- ◆ Poured-concrete loading platform and base
- ◆ Poured-concrete stairs
- ◆ Wood bumpers
- ◆ Man hole covers as per 800 Series plans

Original Penthouses (on types HST-1 and HST-2)

- ◆ Cinder block construction
- ◆ Roof detailing identical to typical 800 Series gabled roof
- ◆ Wood-batten outswinging door

Original Exterior Basement Entrances

- ◆ Poured-concrete foundation walls and footings
- ◆ Poured-concrete steps
- ◆ 1 1/2"-diameter pipe railings

SPECIAL CONSTRUCTION Management Guidelines

Recommended

ORIGINAL SUN PORCHES
ORIGINAL SUN ROOMS
ORIGINAL STOOPS
ORIGINAL AMBULANCE DROP-OFFS
ORIGINAL LOADING DOCKS
ORIGINAL PENTHOUSES
ORIGINAL EXTERIOR BASEMENT
ENTRANCES

Protect, maintain, repair, and replace all elements according to the management guidelines for each material.

Not Recommended

ORIGINAL SUN PORCHES
ORIGINAL SUN ROOMS
ORIGINAL STOOPS
ORIGINAL AMBULANCE DROP-OFFS
ORIGINAL LOADING DOCKS
ORIGINAL PENTHOUSES
ORIGINAL EXTERIOR BASEMENT
ENTRANCES

Failing to observe the management guidelines and general specifications for each material present in Special Construction.

General Specifications

Replacement materials should follow the original 800 Series plans and specifications. Materials should be finished according to general specifications for their type.

**MECHANICAL AND ELECTRICAL:
Character-Defining Features***

Electrical

Exterior and Interior

- ◆ Incandescent lighting
 - Porcelain fixtures
 - Simple stamped-metal shades

Interior

- ◆ Rectangular, beveled-metal switch and outlet plates

* Mechanical components not visible from building exteriors are not included within this management plan.

MECHANICAL AND ELECTRICAL Management Guidelines

Recommended

Protection and Maintenance

Improve the energy efficiency of existing systems to reduce the need for new equipment.

Maintain proper circuit loading to prevent overload or failure.

Repair

Repair original electrical systems by augmenting or upgrading system parts.*

Replacement

Replace with salvage, in-kind, or compatible substitute material those visible features of the original electrical systems that are extensively deteriorated.**

Install new systems in a way that results in the least alteration possible to the building.**

Install the vertical runs of conduit in closets, service rooms, pipe chases, and wall cavities.**

Not Recommended

Protection and Maintenance

Altering visible decorative features of the original electrical system.

Failing to provide adequate protection of materials on a cyclical basis so that deterioration of electrical systems and their visible features results.

Installing unnecessary additional lighting, outlets, and switches.

Overloading existing electrical circuits.

Repair

Replacing all or some of an original electrical system when it could be upgraded and retained.

Replacement

Installing a new electrical system so that significant original structural or exterior features are altered.

Concealing new electrical systems in walls or ceilings in a manner that requires the removal of original building material.

Cutting through relatively inflexible features such as masonry walls in order to install electrical outlets or switches.

Failing to remove non-original electrical system

General Specifications

Replacement elements should consist of first quality materials.

SITE AND DISTRICT: Character-Defining Features

- ◆ Low-slung buildings
- ◆ Corridors both perpendicular and parallel to buildings
- ◆ Uniform appearance and symmetrical arrangement of buildings
- ◆ Rectilinear organization of buildings, corridors, and sidewalks
- ◆ Pattern of solid and void created by courtyards between buildings
- ◆ Relatively undeveloped landscape setting
- ◆ Flat topography

SITE AND DISTRICT Management Guidelines

Recommended

Protection and Maintenance

Protect and maintain the existing topography and the relationship between remaining buildings and courtyards.

Maintain proper site drainage.

Survey and document areas where terrain will be altered during work to determine the potential impact to landscape features or archeological resources.**

Protect, i.e., preserve in place, important archeological resources. Plan and carry out any necessary investigation prior to disturbance when preservation in place is not feasible.**

Manage vegetation to prevent impact on buildings or structures by branches or roots.

Repair

Repair or reinforce original material such as sidewalks, if possible.

Replacement

Replace features, such as sidewalks that are too damaged to repair, with in-kind material.*

Design and install replacement features to assist in energy conservation of nearby buildings.*

Not Recommended

Protection and Maintenance

Retaining known non-historic buildings or landscape features.

Failing to undertake adequate measures to assure the protection of building and landscape features.

Repair

Replacing an original feature of the landscape setting when repair and limited replacement of deteriorated or missing parts is appropriate.

Using a substitute material for the replacement part that does not convey the visual appearance of the surviving parts of the feature or landscape, or that is physically, chemically, or ecologically incompatible.

Replacement

Removing an original feature of the building or landscape that is unrepairable and not replacing it, or failing to document the new work.

Removing a historically compatible landscape feature that assists in energy conservation in nearby buildings.

* Work shall not be initiated without approval of the Colorado Historic Preservation Office (303) 866-3398.

** Work shall not be initiated without approval of the Directorate of Environmental Compliance and Management (719) 526-4652.

General Specifications

Replacement concrete should be mixed according to general specifications as for Concrete.

ACCESSIBILITY CONSIDERATIONS

Management Guidelines

Recommended

Comply with barrier-free access requirements in such a manner that spaces, features, and finishes from the restored period are preserved.

Work with access specialists and Colorado Historic Preservation Office in the design of appropriate access solutions.

Provide barrier-free access that promotes independence to the highest degree practicable, while preserving significant historic features.

Find solutions to meet accessibility requirements, such as those that apply to compatible ramps, paths, and lifts, that minimize the impact on historic buildings and site.

Not Recommended

Altering, damaging, or destroying features from the restored period while attempting to comply with accessibility requirements.

Making access modifications that do not provide a reasonable balance between independent, safe access and preservation of historic features.

Making modifications for accessibility without considering the impact on the historic building and its site.

Historic Building Cyclic Maintenance Schedule
 Old Hospital Complex, Fort Carson

Building No. _____

Task	Reference Note No.	Frequency	Date last evaluated
Weather Envelope			
Roof		Annually	
Walls		Every 5 years	
Porches		Semi-annually	
Doors		Annually	
Windows		Annually	
Structural System			
Wall Exterior, (alignment)		Annually	
Foundation Exterior		Annually	
Foundation Interior		Every 5 years	
Attic Framing		Every 5 years	
Attic Floor		Every 5 years	
Exterior Detail			
Entrance stairs		Annually	
Grounds and Site			
Lawns		Semi-annually	
Planting		Semi-annually	
Sidewalks		Semi-annually	

Historic Building Maintenance Checklist

Old Hospital Complex, Fort Carson

Building No. _____ Date _____

Condition for each building element on this checklist is expressed in terms of function and operation, as well as expected life with no maintenance and normal use.

- Excellent Performing all functions and operations; will continue to perform until next inspection cycle.
 Good Minor limits of function and operation; will perform within limits for at least 1/2 of inspection cycle.
 Fair Major limits of function and operation; limited life due to a condition that will continue to worsen.
 Poor Not performing important functions and operations; at or near end of useful life.

Only items checked off in the left column were evaluated.

Key to Headings
 Major System or Section
 Location or Subsection (Inspection cycle)
 Element (description of element, inspection cycle, and condition)
 Sub-element

Reference to
 further
 details in
 Inspection
 Notes No.

Weather Envelope

	E	G	F	P	
Roof exterior (Annually)					
<input type="radio"/> shingles	<input type="checkbox"/>	<input type="checkbox"/>	<input type="checkbox"/>	<input type="checkbox"/>	_____
<input type="radio"/> flashing	<input type="checkbox"/>	<input type="checkbox"/>	<input type="checkbox"/>	<input type="checkbox"/>	_____
<input type="radio"/> drip edge	<input type="checkbox"/>	<input type="checkbox"/>	<input type="checkbox"/>	<input type="checkbox"/>	_____
<input type="radio"/> dormers	<input type="checkbox"/>	<input type="checkbox"/>	<input type="checkbox"/>	<input type="checkbox"/>	_____
Walls (Every 5 years)					
<input type="radio"/> cornice	<input type="checkbox"/>	<input type="checkbox"/>	<input type="checkbox"/>	<input type="checkbox"/>	_____
<input type="radio"/> paint	<input type="checkbox"/>	<input type="checkbox"/>	<input type="checkbox"/>	<input type="checkbox"/>	_____
<input type="radio"/> cinder blocks (broken, chipped)	<input type="checkbox"/>	<input type="checkbox"/>	<input type="checkbox"/>	<input type="checkbox"/>	_____
<input type="radio"/> paint	<input type="checkbox"/>	<input type="checkbox"/>	<input type="checkbox"/>	<input type="checkbox"/>	_____
<input type="radio"/> mortar joint	<input type="checkbox"/>	<input type="checkbox"/>	<input type="checkbox"/>	<input type="checkbox"/>	_____
<input type="radio"/> gable vents	<input type="checkbox"/>	<input type="checkbox"/>	<input type="checkbox"/>	<input type="checkbox"/>	_____
Porches (Semi-annually)					
<input type="radio"/> foundation	<input type="checkbox"/>	<input type="checkbox"/>	<input type="checkbox"/>	<input type="checkbox"/>	_____
<input type="radio"/> walls	<input type="checkbox"/>	<input type="checkbox"/>	<input type="checkbox"/>	<input type="checkbox"/>	_____
<input type="radio"/> railings	<input type="checkbox"/>	<input type="checkbox"/>	<input type="checkbox"/>	<input type="checkbox"/>	_____
<input type="radio"/> screens	<input type="checkbox"/>	<input type="checkbox"/>	<input type="checkbox"/>	<input type="checkbox"/>	_____
<input type="radio"/> windows	<input type="checkbox"/>	<input type="checkbox"/>	<input type="checkbox"/>	<input type="checkbox"/>	_____
Drainage (Every 5 years)					
<input type="radio"/> diversion channels	<input type="checkbox"/>	<input type="checkbox"/>	<input type="checkbox"/>	<input type="checkbox"/>	_____
<input type="radio"/> flow away from foundation	<input type="checkbox"/>	<input type="checkbox"/>	<input type="checkbox"/>	<input type="checkbox"/>	_____
<input type="radio"/> drains and lines	<input type="checkbox"/>	<input type="checkbox"/>	<input type="checkbox"/>	<input type="checkbox"/>	_____

Doors (Every 5 years)		E	G	F	P	
<input type="radio"/>	paint	<input type="checkbox"/>	<input type="checkbox"/>	<input type="checkbox"/>	<input type="checkbox"/>	_____
<input type="radio"/>	caulking	<input type="checkbox"/>	<input type="checkbox"/>	<input type="checkbox"/>	<input type="checkbox"/>	_____
<input type="radio"/>	glazing	<input type="checkbox"/>	<input type="checkbox"/>	<input type="checkbox"/>	<input type="checkbox"/>	_____
<input type="radio"/>	glazing putty	<input type="checkbox"/>	<input type="checkbox"/>	<input type="checkbox"/>	<input type="checkbox"/>	_____
<input type="radio"/>	surrounds	<input type="checkbox"/>	<input type="checkbox"/>	<input type="checkbox"/>	<input type="checkbox"/>	_____
<input type="radio"/>	sill	<input type="checkbox"/>	<input type="checkbox"/>	<input type="checkbox"/>	<input type="checkbox"/>	_____
<input type="radio"/>	light fixture above door	<input type="checkbox"/>	<input type="checkbox"/>	<input type="checkbox"/>	<input type="checkbox"/>	_____
<input type="radio"/>	hardware	<input type="checkbox"/>	<input type="checkbox"/>	<input type="checkbox"/>	<input type="checkbox"/>	_____

Windows (Annually)		E	G	F	P	
<input type="radio"/>	paint	<input type="checkbox"/>	<input type="checkbox"/>	<input type="checkbox"/>	<input type="checkbox"/>	_____
<input type="radio"/>	caulking	<input type="checkbox"/>	<input type="checkbox"/>	<input type="checkbox"/>	<input type="checkbox"/>	_____
<input type="radio"/>	glazing	<input type="checkbox"/>	<input type="checkbox"/>	<input type="checkbox"/>	<input type="checkbox"/>	_____
<input type="radio"/>	glazing putty	<input type="checkbox"/>	<input type="checkbox"/>	<input type="checkbox"/>	<input type="checkbox"/>	_____
<input type="radio"/>	surrounds	<input type="checkbox"/>	<input type="checkbox"/>	<input type="checkbox"/>	<input type="checkbox"/>	_____
<input type="radio"/>	sill	<input type="checkbox"/>	<input type="checkbox"/>	<input type="checkbox"/>	<input type="checkbox"/>	_____
<input type="radio"/>	screens	<input type="checkbox"/>	<input type="checkbox"/>	<input type="checkbox"/>	<input type="checkbox"/>	_____
<input type="radio"/>	hardware	<input type="checkbox"/>	<input type="checkbox"/>	<input type="checkbox"/>	<input type="checkbox"/>	_____

Structural System

Roof and Wall Exterior (Annually)		E	G	F	P	
<input type="radio"/>	alignment	<input type="checkbox"/>	<input type="checkbox"/>	<input type="checkbox"/>	<input type="checkbox"/>	_____

Foundation Exterior (Annually)		E	G	F	P	
<input type="radio"/>	drainage	<input type="checkbox"/>	<input type="checkbox"/>	<input type="checkbox"/>	<input type="checkbox"/>	_____
<input type="radio"/>	cracking/settling	<input type="checkbox"/>	<input type="checkbox"/>	<input type="checkbox"/>	<input type="checkbox"/>	_____
<input type="radio"/>	foundation vents	<input type="checkbox"/>	<input type="checkbox"/>	<input type="checkbox"/>	<input type="checkbox"/>	_____
<input type="radio"/>	crawl space hatches	<input type="checkbox"/>	<input type="checkbox"/>	<input type="checkbox"/>	<input type="checkbox"/>	_____
<input type="radio"/>	hatch doors	<input type="checkbox"/>	<input type="checkbox"/>	<input type="checkbox"/>	<input type="checkbox"/>	_____
<input type="radio"/>	surrounds	<input type="checkbox"/>	<input type="checkbox"/>	<input type="checkbox"/>	<input type="checkbox"/>	_____

Foundation Interior (Every 5 years)		E	G	F	P	
<input type="radio"/>	evidence of water entry	<input type="checkbox"/>	<input type="checkbox"/>	<input type="checkbox"/>	<input type="checkbox"/>	_____
<input type="radio"/>	evidence of animal entry or infestation	<input type="checkbox"/>	<input type="checkbox"/>	<input type="checkbox"/>	<input type="checkbox"/>	_____

Attic Framing (Every 5 years)		E	G	F	P	
<input type="radio"/>	sheathing	<input type="checkbox"/>	<input type="checkbox"/>	<input type="checkbox"/>	<input type="checkbox"/>	_____
<input type="radio"/>	rafters/trusses	<input type="checkbox"/>	<input type="checkbox"/>	<input type="checkbox"/>	<input type="checkbox"/>	_____
<input type="radio"/>	dormer framing	<input type="checkbox"/>	<input type="checkbox"/>	<input type="checkbox"/>	<input type="checkbox"/>	_____

Attic Floor (Every 5 years)		E	G	F	P	
<input type="radio"/>	plates	<input type="checkbox"/>	<input type="checkbox"/>	<input type="checkbox"/>	<input type="checkbox"/>	_____
<input type="radio"/>	joists	<input type="checkbox"/>	<input type="checkbox"/>	<input type="checkbox"/>	<input type="checkbox"/>	_____
<input type="radio"/>	flooring	<input type="checkbox"/>	<input type="checkbox"/>	<input type="checkbox"/>	<input type="checkbox"/>	_____
<input type="radio"/>	insulation	<input type="checkbox"/>	<input type="checkbox"/>	<input type="checkbox"/>	<input type="checkbox"/>	_____

Exterior Detail

Entrance Stairs (Annually)

	E	G	F	P	
<input type="radio"/> treads	<input type="checkbox"/>	<input type="checkbox"/>	<input type="checkbox"/>	<input type="checkbox"/>	_____
<input type="radio"/> risers	<input type="checkbox"/>	<input type="checkbox"/>	<input type="checkbox"/>	<input type="checkbox"/>	_____
<input type="radio"/> carriage	<input type="checkbox"/>	<input type="checkbox"/>	<input type="checkbox"/>	<input type="checkbox"/>	_____
<input type="radio"/> supports	<input type="checkbox"/>	<input type="checkbox"/>	<input type="checkbox"/>	<input type="checkbox"/>	_____
<input type="radio"/> paint	<input type="checkbox"/>	<input type="checkbox"/>	<input type="checkbox"/>	<input type="checkbox"/>	_____
<input type="radio"/> concrete pier	<input type="checkbox"/>	<input type="checkbox"/>	<input type="checkbox"/>	<input type="checkbox"/>	_____

Grounds and Site

<input type="radio"/> Lawns (Semi-annually)	<input type="checkbox"/>	<input type="checkbox"/>	<input type="checkbox"/>	<input type="checkbox"/>	_____
<input type="radio"/> Plantings (Semi-annually) Endangering Building?	<input type="checkbox"/> Yes		<input type="checkbox"/> No		_____
<input type="radio"/> Sidewalks (Semi-annually)	<input type="checkbox"/>	<input type="checkbox"/>	<input type="checkbox"/>	<input type="checkbox"/>	_____

Inspection Note No: _____

Building No. _____

Prepared by: _____

Type of Work

- Repair Preventive Maintenance Cyclic: _____ times per _____
 Corrective Maintenance One Time Custodial

Problem (include location and elements affected): _____

Proposed Treatment (Refer to Historic Building Management Record for past treatments):

Inspection Note No: _____

Building No. _____

Prepared by: _____

Type of Work

- Repair Preventive Maintenance Cyclic: _____ times per _____
 Corrective Maintenance One Time Custodial

Problem (include location and elements affected): _____

Proposed Treatment (Refer to Historic Building Management Record for past treatments):

Inspection Note No: _____

Building No. _____

Prepared by: _____

Type of Work

- Repair Preventive Maintenance Cyclic: _____ times per _____
 Corrective Maintenance One Time Custodial

Problem (include location and elements affected): _____

Proposed Treatment (Refer to Historic Building Management Record for past treatments):

Reference Materials

Architectural Drawing Index

Management and Maintenance Plan
Old Hospital Complex, Fort Carson

Overview:

This section includes an index of drawings available at the Fort Carson Directorate of Public Works. Additional drawings not on file at Fort Carson may be found at:

- U.S. Army Corps of Engineers Office of History, Fort Belvoir, VA.
- U.S. Army Corps of Engineers Technical Center of Expertise for Preservation of Historic Structures and Buildings, Seattle, WA.
- U.S. Army Corps of Engineers Construction Engineering Research Laboratories, Facilities Technology Laboratory, Maintenance, Management and Preservation Division.

Bldg. No.	Building Type	Construction Code	Plan Description	Revisions
Complex	Mobilization Hospital Buildings	800-1751	Miscellaneous Details	
Complex	Mobilization Hospital Buildings	800-1754	Miscellaneous Details	
Complex	Mobilization Hospital Buildings	800-1756	Miscellaneous Details	
Complex	Site Plan of Complex	CCH-1.12 F	Additions to Existing Facilities Part III	05-20-45
Complex	Complex Site Plan	CCH-1.9 -F	Additions to Existing Facilities Part II and III	08-29-45
Complex	Complex	PEA-399.1 -F	Replacement of wood stairs and ramps.	06-08-53
Complex	Complex	PEA-599.5	Area Plan of Complex showing new concrete porches.	06-09-53
Corridor	Corridor South of S-6222	32-02-02 -F	Framing Plan and Lintel Details, Modernization Floor Plan	10-13-72
Corridor	Corridor under Hospital Modernization between S6226 and S6233	32-02-02 -F	Roof and Wall Details	
Corridor	Corridors under Hospital Modernization	32-02-02 -F	Cross Section and Details.	10-13-72
Corridor	Corridors under Hospital Modernization	32-02-02 -F	Elevations	
Corridor	Corridor South of 6222	32-02-03 -F	Elevations and Floor Plan	04-19-72
Corridor	Corridor Between 6225 and 6226	CCH-3.50 -F	First and Second Floor, Framing, and Sections	06-05-45
Corridor	Corridor Between 6225 and 6226	CCH-3.51 -F	Elevations, Details, and Sections	06-09-45
Corridor	Corridor Between S-6225 and S-6226	CCH-7.38 -F	Second Floor Plan	
Corridor	Corridor Between S-6225 and S-6226	CCH-6.17 -F	First and Second Floor Plans, Section	06-16-45
N/A	All Complex Buildings	32-01-01 -F	Typical Masonry Details	
N/A	Northwest Quadrant of the Complex	32-01-01 -F	Electrical Distribution	
N/A	S-6233, S-6240, S-6236, and S-6237	32-02-02 -F	Hospital Modernization, Floor Plans For Added Equipment	10-13-72
N/A	Improve Medical Facilities, Dispensaries and Clinics	32-02-03 -F	Counter Details	
N/A	Improve Medical Facilities, Dispensaries and Clinics	32-02-03 -F	Details	
N/A	Improve Medical Facilities, Dispensaries and Clinics	32-02-03 -F	Details	
N/A	Improve Medical Facilities, Dispensaries and Clinics	32-02-03 -F	Details	
N/A	Improved Medical Facilities, Dispensaries and Clinics	32-02-03 -F	Details	
N/A	Miscellaneous	800-1753	Miscellaneous Details, Furniture, Dark Rooms, and X-Ray	N/A
N/A	Hospital	800-2159	Utility Distribution	
N/A	Hospital	800-2162	Utility Distribution	
N/A	Covered Walkways (Corridor System)	800-3192	Sprinkler System	
N/A	Hospital	Unknown	Utility Distribution	
S-6220	CSA Series Building	32-02-03 -F	First Floor Plan	06-28-71
S-6220	CSA Series Building	32-02-03 -F	Second Floor Plan, Renovate Dispensaries and Clinics	
S-6220	CSA Series	B.U.D.	First Floor Plan	
S-6220	CSA Series	B.U.D.	Second Floor Plan	
S-6220	CSA Series Building	Numeric F	First and Second Floor Plans	05-09-58
S-6221	Nurses Mess and Kitchen, Type HNM-600	32-02-03 -F	Floor Plan	N/A
S-6221	Nurses Mess and Kitchen, Type HNM-220	800-2045	Foundation Floor Plan, Roof Framing Plan	
S-6221	Nurses Mess and Kitchen, Type HNM-220	800-2046	Floor Plans and Details	
S-6221	Nurses Mess and Kitchen, Type HNM-220	800-2047	Elevations and Sections	
S-6221	Nurses Mess and Kitchen, Type HNM-220	800-2050	Electrical and Refrigeration	N/A
S-6221	Nurses Mess and Kitchen, Type HNM-220	B.U.D.	First Floor Plan	
S-6222	Hospital Nurses or Officers Quarters, Type HNQ-63 or HOQ-63	32-02-03 -F	Second Floor Plan, East Half of Building	04-19-73
S-6222	Hospital Nurses or Officers Quarters, Type HNQ-63 or HOQ-63	32-02-03 -F	Second Floor Plan, West Half of Building	04-19-73
S-6222	Hospital Nurses or Officers Quarters, Type HNQ-63 or HOQ-63	32-02-03 -F	First Floor Plan, East Half of Building	04-19-73
S-6222	Hospital Nurses or Officers Quarters, Type HNQ-63 or HOQ-63	32-02-03 -F	First Floor Plan, West Half of Building	04-19-73

Bldg. No.	Building Type	Construction Code	Plan Description	Revisions
S-6222	Hospital Nurses or Officer Quarters, Type HNQ-63 or HOQ-63.	B.U.D.	Second Floor Plan	
S-6222	Hospital Nurses or Officers Quarters, Type HNQ-63 or HOQ-63.	B.U.D.	First Floor Plan	
S-6222	Hospital Nurses or Officers Quarters, Type HNQ-63 or HOQ-63	F.U.S.	First Floor Plan	
S-6222	Hospital Nurses or Officers Quarters, Type HNQ-63 or HOQ-63.	F.U.S.	Second Floor Plan	
S-6223	Nurses or Officers Quarters, Type HNQ-31 or HOQ-31	32-02-03 -F	First Floor Plan, East Half of Building	04-19-73
S-6223	Nurses or Officers Quarters, Type HNQ-31 or HOQ-31	32-02-03 -F	First Floor Plan, West Half of Building	04-19-73
S-6223	Nurses or Officers Quarters, Type HNQ-31 or HOQ-31	800-18**	First Floor Plan and Roof Framing	Original 11-27-41
S-6223	Nurses or Officers Quarters, Type HNQ-31 or HOQ-31	800-1822	Foundation and First Floor Framing Plans	Original 11-26-41
S-6223	Nurses or Officers Quarters, Type HNQ-31 or HOQ-31.	800-1829	Elevations and Sections	
S-6223	Nurses or Officers Quarters, Type HNQ-31 or HOQ-31.	B.U.D.	First Floor Plan	
S-6223	Nurses or Officers Quarters, Type HNQ-31 or HOQ-31.	DK	Floor Plan, Rehabilitation	DK
S-6223	Nurses or Officers Quarters, Type HNQ-31 or HOQ-31.	F.U.S.	First Floor Plan	
S-6223	Nurses or Officers Quarters, Type HNQ-31 or HOQ-31	PEM 194.10	First Floor Plan Heating Layout	07-12-51
S-6224	Hospital Nurses or Officers Quarters, Type HNQ-63 or HOQ-63	800-1834	First and Second Floor Framing Plans	Original 11-27-41
S-6224	Hospital Nurses or Officers Quarters, Type HNQ-63 or HOQ-63	800-1835	Foundation, Attic, and Roof Framing	Original 11-27-41
S-6224	Hospital Nurses or Officers Quarters, Type HNQ-63 or HOQ-63	800-1836	First and Second Floor Plans	Original 11-27-41
S-6224	Hospital Nurses or Officers Quarters, Types HNQ-63 or HOQ-63	800-1837	Elevations and Sections	
S-6224	Hospital Nurses or Officers Quarters, 63,74,85	800-1849	Elevations and Sections	
S-6224	Hospital Nurses or Officers Quarters, 63,74,85	800-1856	Second Floor Heating	
S-6224	Hospital Nurses or Officers Quarters, 63,74,85	800-1860	Second Floor Heating	
S-6224	Hospital Nurses or Officers Quarters, 63,74,85	800-1862	Second Floor Heating	
S-6224	Hospital Nurses or Officers Quarters, 63,74,85	800-1864	Second Floor Heating	
S-6224	Hospital Nurses or Officers Quarters, 63,74,85	800-1868	Second Floor Heating	
S-6224	Hospital Nurses or Officers Quarters, Types 63, 74, and 85.	B.U.D.	First Floor Plan	
S-6224	Hospital Nurses or Officers Quarters, Types 63, 74, and 85.	B.U.D.	Second Floor Plan	
S-6225	Administration Building, Type HAB-1	800-2033	Elevations and Details	
S-6225	Administration Building, Type HAB-1	800-2034	Plumbing	
S-6225	Administration Building, Type HAB-1	800-2035	Heating Diagrams	
S-6225	Hospital Administration Building, Type HAB-1	CCH -F	First and Second Floor Plans	09-14-45
S-6225	Administration Building, Type HAB-1	CCH-3.115 -F	Sections and Details	
S-6225	Administration Building, Type HAB-1	CCH-3.121 -F	Section and Details	
S-6225	Administration Building, Type HAB-1	CCH-3.71 -F	Foundation and First Floor Framing Plans	06-26-45
S-6225	Administration Building, Type HAB-1	CCH-3.73 -F	Roof Framing and Details	06-21-45
S-6225	Administration Building, Type HAB-1	CCH-3.74 -F	Elevations	
S-6225	Administration Building, Type HAB-1	CCH-5.16 -F	Foundation, First, and Second Floor Heating	04-18-45
S-6225	Administration Building, Type HAB-1	CCH-5.27 -F	First and Second Floor Steam Heating	06-22-45
S-6225	Administration Building, Type HAB-1	CCH-5.28 -F	First (and Second) Floor Piping	06-25-45
S-6225	Administration Building, Type HAB-1	CCH-5.29 -F	First and Second Floor Plumbing	06-25-45
S-6225	Administration Building, Type HAB-1	CCH-7.25 -F	First and Second Floor Plans	04-25-45
S-6225	Administration Building, Type HAB-1	CCH-7.37 -F	Floor Plans and Sections, Thermal Detectors	06-27-45
S-6226	Administration and Receiving, Type HAR-1	800-1928	Elevations	
S-6226	Administration and Receiving, Type HAR-1	800-1932	Plumbing	
S-6226	Administration and Receiving, Type HAR-1	800-1933	Heating	
S-6226	Administration and Receiving, Type HAR-1	CCH-?-F	First Floor Plan, Plumbing	DK 05-08-45

Bldg. No.	Building Type	Construction Code	Plan Description	Revisions
S-6226	Administration and Receiving, Type HAR-1	CCH-3.3 -F	Miscellaneous Construction Details	04-25-45
S-6226	Administration and Receiving, Type HAR-1	CCH-3.31 -F	Elevations and Sections	05-08-45
S-6226	Administration and Receiving, Type HAR-1	CCH-3.32 -F	Foundation and Floor Framing	04-19-45
S-6226	Administration and Receiving, Type HAR-1	CCH-3.33 -F	Second Floor Ceiling and Roof Framing Plans	
S-6226	Administration and Receiving, Type HAR-1	CCH-3.34 -F	First Floor Plan	
S-6226	Administration and Receiving, Type HAR-1	CCH-3.35 -F	Second Floor Plan	
S-6226	Administration and Receiving, Type HAR-1	CCH-5.13 -F	Foundation, First, and Second Floor Heating of Wings.	05-08-45
S-6226	Administration and Receiving, Type HAR-1	CCH-5.15 -F	First and Second Floor Heating	06-12-45
S-6226	Administration and Receiving, Type HAR-1	CCH-6.2 -F	First Floor Electrical	
S-6226	Administration and Receiving, Type HAR-1	CCH-6.3 -F	Second Floor Electrical	
S-6226	Administration and Receiving, Type HAR-1	CCH-7.31 -F	Second Floor Plan, Partial First, and Section Generator Building Plans and Details	05-04-45
S-6229	Administration and Receiving, Type HAR-1	32-01-01 -F	Landscape Plan and Schedule	10-08-76
S-6229	Numeric Series	Film 32-01-01		N/A
S-6229	Numeric Series	800-1944	Second Floor Architectural and Framing	
S-6230	Combination Ward, Type HCW-88	800-1945	Elevations and Sections	
S-6230	Combination Ward, Type HCW-88	800-1946	First and Second Floor Heating Plan	N/A
S-6230	Combination Ward, Type HCW-88	800-1935	First Floor Architectural and Framing	N/A
S-6231	Standard Ward, Type HSW-98	800-1936	Second Floor Architectural and Framing	N/A
S-6231	Standard Ward, Type HSW-98	800-1937	Elevations and Sections	
S-6232	Pharmacy in Hospital	32-52-01 -F	Sections and Details	
S-6232	Pharmacy in Hospital	32-52-01 -F	Sections and Details	
S-6232	Pharmacy in Hospital	32-52-01 -F	Floor Plan and Schedules	07-07-69
S-6232	Central Services and Occupational Therapy, Clinic Building	CCH-3.7 -F	Elevations and Sections	
S-6232	Central Services and Occupational Therapy, Clinic Building	CCH-3.10 -F	First and Second Floor Plans	05-10-45
S-6232	Central Services and Occupational Therapy, Clinic Building	CCH-3.44 -F	Second Floor and Roof Framing	05-25-45
S-6232	Central Services and Occupational Therapy, Clinic Building	CCH-3.47 -F	Foundation and First Floor Plans and Details	05-19-46
S-6232	Central Services and Occupational Therapy, Clinic Building	CCH-5.23 -F	Foundation and First Floor Heating	06-10-45
S-6232	Central Services and Occupational Therapy, Clinic Building	CCH-5.24 -F	First and Second Floor Plumbing	06-15-45
S-6232	Central Services and Occupational Therapy, Clinic Building	CCH-5.24 -F	First and Second Floor Plumbing	06-15-45
S-6232	Central Services and Occupational Therapy, Clinic Building	CCH-6.15 -F	First and Second Floor Electrical	05-28-45
S-6232	Central Services and Occupational Therapy, Clinic Building	CCH-7.33 -F	Floor Plans and Section	
S-6235	Standard Ward, Type HSW-98	B.U.D.	First Floor Plan	
S-6235	Standard Ward, Type HSW-98	B.U.D.	Second Floor Plan	
S-6236	Special Ward, Type HSPW-76	800-1951	First Floor Architectural and Framing	N/A
S-6236	Special Ward, Type HSPW-76	800-1952	Second Floor Architectural and Framing	
S-6236	Special Ward, Type HSPW-76	800-1956	Elevations and Sections	
S-6241	Standard Ward, Type HSW-98	B.U.D.	First Floor Plan	
S-6241	Standard Ward, Type HSW-98	B.U.D.	Second Floor Plan	
S-6243	Clinic, Type HC-1	800-1907	Foundation Plan and Details	Original 11-27-41
S-6243	Clinic, Type HC-1	800-1908	First Floor Plan and Framing Diagram	Original 11-27-41
S-6243	Clinic, Type HC-1	800-1909	Second Floor Plan and Framing Diagram	Original 11-27-41
S-6243	Clinic, Type HC-1	800-1910	Elevations and Sections	
S-6243	Clinic, Type HC-1	F.U.S.	First Floor Plan	
S-6243	Clinic, Type HC-1	F.U.S.	Second Floor Plan	

Bldg. No.	Building Type	Construction Code	Plan Description	Revisions
S-6244	Standard Ward, Type HSW-98	32-02-02 -F	Hospital Modernization, Malaria Ward Plans	10-16-70
S-6247	Special Ward, Type HSPW-76	B.U.D.	First Floor Plan	
S-6247	Special Ward, Type HSPW-76	B.U.D.	Second Floor Plan	
S-6247	Special Ward, Type HSPW-76	F.U.S.	First Floor Plan	
S-6247	Special Ward, Type HSPW-76	F.U.S.	Second Floor Plan	
S-6248	Standard Ward, Type HSW-98	B.U.D.	First Floor Plan	
S-6248	Standard Ward, Type HSW-98	B.U.D.	Second Floor Plan	
S-6248	Standard Ward, Type HSW-98	F.U.S.	First Floor Plan	
S-6248	Standard Ward, Type HSW-98	F.U.S.	Second Floor Plan	
S-6249	Standard Ward, Type HSW-98	F.U.S.	First Floor Plan	
S-6249	Standard Ward, Type HSW-98	F.U.S.	Second Floor Plan	
S-6250	Patients Mess and Kitchen, Type HPM-600	800-2059	Foundation Plan	
S-6250	Patients Mess and Kitchen, Type HPM-600	800-2060	Floor Framing Plan	
S-6250	Patients Mess and Kitchen, Type HPM-600	800-2061	Floor Plan	
S-6250	Patients Mess and Kitchen, Type HPM-600	800-2062	Roof and Ceiling Framing Plans	N/A
S-6250	Patients Mess and Kitchen, Type HPM-600	800-2063	Elevations	
S-6250	Patients Mess and Kitchen, Type HPM-600	800-2064	Sections	
S-6250	Patients Mess and Kitchen, Type HPM-600	800-2066	Plumbing Diagrams	
S-6250	Patients Mess and Kitchen, Type HPM-600	800-2067	Heating (reverse image)	N/A
S-6250	Patients Mess and Kitchen, Type HPM-600	800-2068	Electrical and Refrigeration Diagrams	Original 11-27-41
S-6251	Hospital Patients Recreation Building, Type HPRB-1	800-1800	Footings and First Floor Framing Plans	Original 11-27-41
S-6251	Hospital Patients Recreation Building, Type HPRB-1	800-1801	Second Floor, Attic, and Roof Framing Plans	Original 11-27-41
S-6251	Hospital Patients Recreation Building, Type HPRB-1	800-1802	First and Second Floor Plans	Original 11-27-41
S-6251	Hospital Patients Recreation, Type HPR B-1	800-1803	Elevations and Sections	
S-6251	Hospital Patients Recreation Building, Type HPRB-1	800-1804	Miscellaneous Details	
S-6251	Hospital Patients Recreation Building, Type HPR B-1	800-1805	Plumbing Diagram	N/A
S-6253	Neuropsychiatric Ward, Type HNPW-82	800-1958	First Floor Architectural and Framing (2)	N/A
S-6253	Neuropsychiatric Ward, Type HNPW-82	800-1959	Second Floor Architectural and Framing (2)	N/A
S-6253	Neuropsychiatric Ward, Type HNPW-82	800-1960	First and Second Floor Heating Diagrams	N/A
S-6253	Neuropsychiatric Ward, Type HNPW-82	800-1961	Plumbing Diagram	
S-6253	Neuropsychiatric Ward, Type HNPW-82	800-1962	Elevations and Sections	
S-6254	Neuropsychiatric Ward, Type HNPW-82	B.U.D.	First Floor Plan	
S-6254	Neuropsychiatric Ward, Type HNPW-82	B.U.D.	Second Floor Plan	
S-6255	Standard Ward, Type HSW-98	B.U.D.	First Floor Plan	
S-6255	Standard Ward, Type HSW-98	B.U.D.	Second Floor Plan	
S-6260	Proposed Alterations Building, Radio Broadcast Station	PEA-386 -F	Floor Plan, Section, Elevation, Alterations	09-05-54
S-6260	Proposed Alterations Building, Radio Broadcast Station	PEA-392 -F	Proposed Modifications, Floor Plan	03-03-53
S-6260	Proposed Alterations Building, Radio Broadcast Station.	PEM 160-P-F	Floor Plan, Proposed Sprinkler Layout	08-23-58
S-6261	Hospital Post Exchange, Type HPE-1	800-1818	Foundation and First Floor Framing and Details	Original 11-28-41
S-6261	Hospital Post Exchange, Type HPE-1	800-1820	Heating Diagrams	
S-6261	Hospital Post Exchange, Type HPE-1	800-1821	Elevations and Sections	
S-6261	Hospital Post Exchange, Type HPE-1	800-1823	Second Floor Plumbing Diagram	N/A
S-6261	Hospital Post Exchange, Type HPE-1	800-1828	First Floor Plan and Second Floor Framing	Original 11-28-41
S-6261	Hospital Post Exchange, Type HPE-1	800-1829	Second Floor Plan and Roof Framing	Original 11-28-41

Bldg. No.	Building Type	Construction Code	Plan Description	Revisions
S-6261	Hospital Post Exchange, Type HPE-1	CCH-? -F	Elevations	
S-6261	Hospital Post Exchange, Type HPE-1	CCH-3.23	First Floor Framing Plan and Details	05-23-45
S-6261	Hospital Post Exchange, Type HPE-1	CCH-3.25 -F	Roof and Second Floor Framing Plans	05-28-45
S-6261	Hospital Post Exchange, Type HPE-1	CCH-3.39 -F	First Floor Plan and Small Details	04-28-45
S-6261	Hospital Post Exchange, Type HPE-1	CCH-3.40 -F	Second Floor Plan	
S-6261	Hospital Post Exchange, Type HPE-1	CCH-3.41 -F	Foundation Plan and Details	05-02-45
S-6261	Hospital Post Exchange, Type HPE-1	CCH-3.52 -F	Elevator Addition Floor Plans and Section	08-09-45
S-6261	Hospital Post Exchange, Type HPE-1	CCH-4.13 -F	Elevator Addition, Structural Steel Details	08-08-45
S-6261	Hospital Post Exchange, Type HPE-1	CCH-5.10 -F	First Floor Plan Heating	
S-6261	Hospital Post Exchange, Type HPE-1	CCH-5.21 -F	First Floor Plan Plumbing	05-10-45
S-6261	Hospital Post Exchange, Type HPE-1	CCH-6.1 -F	First Floor Electrical	
S-6262	Hospital Post Exchange, Type HPE-1	CCH-7.32 -F	Floor Plan and Section	
S-6262	Special Ward, Type HSPW-76	F.U.S.	First Floor Plan	
S-6262	Special Ward, Type HSPW-76	F.U.S.	Second Floor Plan	
S-6263	Special Ward, Type HSPW-76	B.U.D.	First Floor Plan	
S-6263	Special Ward, Type HSPW-76	B.U.D.	Second Floor Plan	
S-6263	Special Ward, Type HSPW-76	F.U.S.	First Floor Plan	
S-6263	Special Ward, Type HSPW-76	F.U.S.	Second Floor Plan	
S-6264	Special Ward, Type HSPW-76	B.U.D.	First Floor Plan	
S-6264	Special Ward, Type HSPW-76	B.U.D.	Second Floor Plan	
S-6264	Special Ward, Type HSPW-76	F.U.S.	First Floor Plan	
S-6265	Special Ward, Type HSPW-76	B.U.D.	Second Floor Plan	
S-6265	Special Ward, Type HSPW-76	F.U.S.	First Floor Plan	
S-6265	Special Ward, Type HSPW-76	B.U.D.	Second Floor Plan	
S-6265	Special Ward, Type HSPW-76	F.U.S.	First Floor Plan	
S-6265	Special Ward, Type HSPW-76	B.U.D.	Second Floor Plan	
S-6266	Standard Ward, Type HSW-98	F.U.S.	First Floor Plan	
S-6266	Standard Ward, Type HSW-98	B.U.D.	Second Floor Plan	
S-6266	Standard Ward, Type HSW-98	F.U.S.	First Floor Plan	
S-6266	Standard Ward, Type HSW-98	B.U.D.	Second Floor Plan	
S-6267	Standard Ward, Type HSW-98	F.U.S.	First Floor Plan	
S-6267	Standard Ward, Type HSW-98	B.U.D.	Second Floor Plan	
S-6267	Standard Ward, Type HSW-98	F.U.S.	First Floor Plan	
S-6267	Standard Ward, Type HSW-98	B.U.D.	Second Floor Plan	
S-6267	Standard Ward, Type HSW-98	F.U.S.	First Floor Plan	
S-6267	Standard Ward, Type HSW-98	B.U.D.	Second Floor Plan	
S-6268	Numeric Series	F.U.S.	First Floor Plan	
S-6268	Numeric Series	F.U.S.	First Floor Plan	
S-6270	Storehouse, Type HST-1	800-????	First and Second Floor Plans Electrical	Original 11-21-41
S-6270	Storehouse, Type HST-1	800-1887	Foundation Plan, Details, Vault Details	Original 11-21-41
S-6270	Storehouse, Type HST-1	800-1888	First Floor Plan and Framing Diagram	Original 11-21-41
S-6270	Storehouse, Type HST-1	800-1889	Second Floor Plan and Framing Diagram	Original 11-21-41
S-6270	Storehouse, Types HST-1 and HST-2	800-1891	Typical Details	
S-6270	Storehouse, Type HST-1	800-1892	First and Second Floor Plans, Plumbing	Original 11-21-41

Bldg. No.	Building Type	Construction Code	Plan Description	Revisions
S-6270	Storehouse, Types HST-1 and HST-2	800-1895	Alternate Structural Details, for Foundation	Original 11-27-41
S-6270	Storehouse, Type HST-1	800-1938	First and Second Floor Plans, Heating	Original 11-21-41
S-6270	Storehouse, Type HST-1	CCH-3.143 -F	Foundation Plan, Framing, and Elevations	07-24-45
S-6271	Storehouse, Type HST-2	800-1897	Foundation Plans and Details	Original 11-27-41
S-6271	Storehouse, Type HST-2	800-1898	First Floor Plan and Framing Diagram	Original 11-19-41
S-6271	Storehouse, Type HST-2	800-1899	Second Floor Plan and Framing Diagram	Original 11-19-41
S-6271	Storehouse, Type HST-2	800-1900	Roof Framing, Elevations, and Sections	N/A
S-6271	Storehouse, Type HST-2	800-1900	Roof Framing, Sections, and Elevations	Original 11-19-41
S-6271	Storehouse, Type HST-2	800-1901	First and Second Floor Plans, Plumbing	Original 11-19-41
S-6271	Storehouse, Type HST-2	800-1902	First and Second Floor Plans, Heating	Original 11-19-41
S-6271	Storehouse, Type HST-2	800-1903	First and Second Floor Plans, Electrical	Original 11-19-41
S-6273	Morgue, Type HMO-1	800-1883	Plans and Elevations, Plus Schedule	Original 11-07-41
S-6273	Morgue, Type HMO-1	800-1884	Heating Layout	
S-6273	Morgue, Type HMO-1	800-1885	Plumbing and Electrical Diagrams	Original 11-07-41
S-6274	Shop, Type HSH-1	800-1873	Floor Plans, Elevations, and Details	N/A
S-6274	Shop, Type HSH-1	800-1879	Plans, Elevations, Details, and Schedule	Original 11-15-41
S-6274	Shop, Type HSH-1	800-1880	Electrical and Plumbing	
S-6275	Flammable Materials Storehouse	800-2006	Floor Plans, Elevations, Plumbing, Electrical, Heating, and Details	N/A
S-6276	Utility Shop, Type HUS-1	800-2008	Plans, Elevations, and Sections	Original 11-20-41
S-6280	Medical Detachment Barracks, Type HMDB-133	800-1918	First Floor and Framing Plans	N/A
S-6280	Medical Detachment Barracks, Type HMDB-133	800-1919	Second Floor and Framing Plans	N/A
S-6280	Medical Detachment Barracks, Type HMDB-133	800-1919	Second Floor Plan and Framing Plan	Original 11-29-41
S-6280	Medical Detachment Barracks, Type HMDB-133	800-1920	Elevations	
S-6280	Medical Detachment Barracks, Type HMDB-133	B.U.D.	First Floor Plan	
S-6280	Medical Detachment Barracks, Type HMDB-133	B.U.D.	Second Floor Plan	
S-6280	Medical Detachment Barracks, Type HMDB-133	CCH-? -F	Fire Escape to Roof of Covered Walk	06-09-45
S-6280	Medical Detachment Barracks, Type HMDB-133	CCH-6.9 -F	First and Second Floor Electrical	04-27-45
S-6280	Medical Detachment Barracks, Type HMDB-133	F.U.S.	First Floor Plan	
S-6280	Medical Detachment Barracks, Type HMDB-133	F.U.S.	Second Floor Plan	
S-6281	Medical Detachment Barracks, Type HMDB-133	F.U.S.	First Floor Plan	
S-6281	Medical Detachment Barracks, Type HMDB-133	F.U.S.	Second Floor Plan	
S-6282	Medical Detachment Barracks, Type HMDB-133	F.U.S.	First Floor Plan	
S-6282	Medical Detachment Barracks, Type HMDB-133	F.U.S.	Second Floor Plan	
S-6283	Medical Detachment Barracks, Type HMDB-133	F.U.S.	First Floor Plan	
S-6284	Medical Detachment Barracks, Type HMDB-133	F.U.S.	Second Floor Plan	
S-6284	Medical Detachment Barracks, Type HMDB-133	F.U.S.	First Floor Plan	
S-6285	Medical Detachment Barracks, Type HMDB-133	F.U.S.	Second Floor Plan	
S-6285	Medical Detachment Barracks, Type HMDB-133	F.U.S.	First Floor Plan	
S-6285	Medical Detachment Barracks, Type HMDB-133	F.U.S.	Second Floor Plan	
S-6286	Medical Detachment Mess and Kitchen, Type HMDM-460	38-04-03 -F	First Floor Plan, Mechanical and Details	12-03-64
S-6286	Medical Detachment Mess and Kitchen, Type HMDM-460	38-04-03 -F	Floor Plan, Section, and Details	12-03-64
S-6286	Medical Detachment Mess and Kitchen, Type HMDM-460	38-04-04 -F	Floor Plans and Details, Alterations	06-21-66
S-6286	Medical Detachment Mess and Kitchen, Type HMDM-460	800-2067 (2)	Foundation Plan	
S-6286	Medical Detachment Mess and Kitchen, Type HMDM-460	800-2070	Floor Framing Plan and Details	N/A

Bldg. No.	Building Type	Construction Code	Plan Description	Revisions
S-6286	Medical Detachment Mess and Kitchen, Type HMDM-460	800-2071 (2)	Floor Plan	
S-6286	Medical Detachment Mess and Kitchen, Type HMDM-460	800-2072	Roof Framing Plan and Details	N/A
S-6286	Medical Detachment Mess and Kitchen, Type HMDM-460	800-2073 (A)	Elevations and Sections	
S-6286	Medical Detachment Mess and Kitchen, Type HMDM-460	800-2073 (B)	Heating Diagram	
S-6286	Medical Detachment Mess and Kitchen, Type HMDM-460	800-2074	Plumbing Diagram	
S-6286	Medical Detachment Mess and Kitchen, Type HMDM-460	800-2076	Electrical and Refrigeration Diagrams	N/A
S-6286	Medical Detachment Mess and Kitchen, Type HMDM-460	B.U.D.	First Floor Plan	
S-6286	Medical Detachment Mess and Kitchen, Type HMDM-460	F.U.S.	First Floor Plan	
S-6286	Medical Detachment Mess and Kitchen, Type HMDM-460	Film 38-04-01	Elevations and Details	
S-6287	Hospital Medical Detachment Recreation, Type HMDR-1	800-1811	Second Floor Plan, Framing, and Roof Framing	Original 11-28-41q
S-6287	Hospital Medical Detachment Recreation, Type HMDR-1	800-1812	Elevations and Sections	
S-6287	Hospital Medical Detachment Recreation, Type HMDR-1	F.U.S.	First Floor Plan	
S-6287	Hospital Medical Detachment Recreation, Type HMDR-1	F.U.S.	Second Floor Plan	
S-6287	Hospital Medical Detachment Recreation, Type HMDR-1	PEM-1150	Foundation and First Floor Plans	Renovation 1992
S-6288	Garage, Type HG-8	800-1877	Sections and Miscellaneous Details	Original 11-01-41
S-6288	Garage, Type HG-8	800-1878	Heating, Plumbing, and Electrical	Original 11-01-41
S-6290	Steam Plant, Type HSP-8, -9, -10, and -11	26-02-08 -F	Floor Plan, Heating Plant Modifications	02-10-81
S-6290	Steam Plant, Type HSP-8, -9, -10, and -11	26-02-08 -F	Structural Sections	
S-6290	Steam Plant, Type HSP-8, -9, -10, and -11	26-02-08 -F	Floor Plan, Heating Plant Modifications	02-10-81
S-6290	Steam Plant, Types HSP-8, -9, -10, and -11	800-2216	Elevations, Sections, and Details	N/A
S-6290	Steam Plant, Types HSP-8, -9, -10, and -11	800-2217	Structural Framing Plans and Details	N/A

The Secretary
of the Interior's
Standards for
Rehabilitation &
Illustrated
Guidelines
for
Rehabilitating
Historic
Buildings

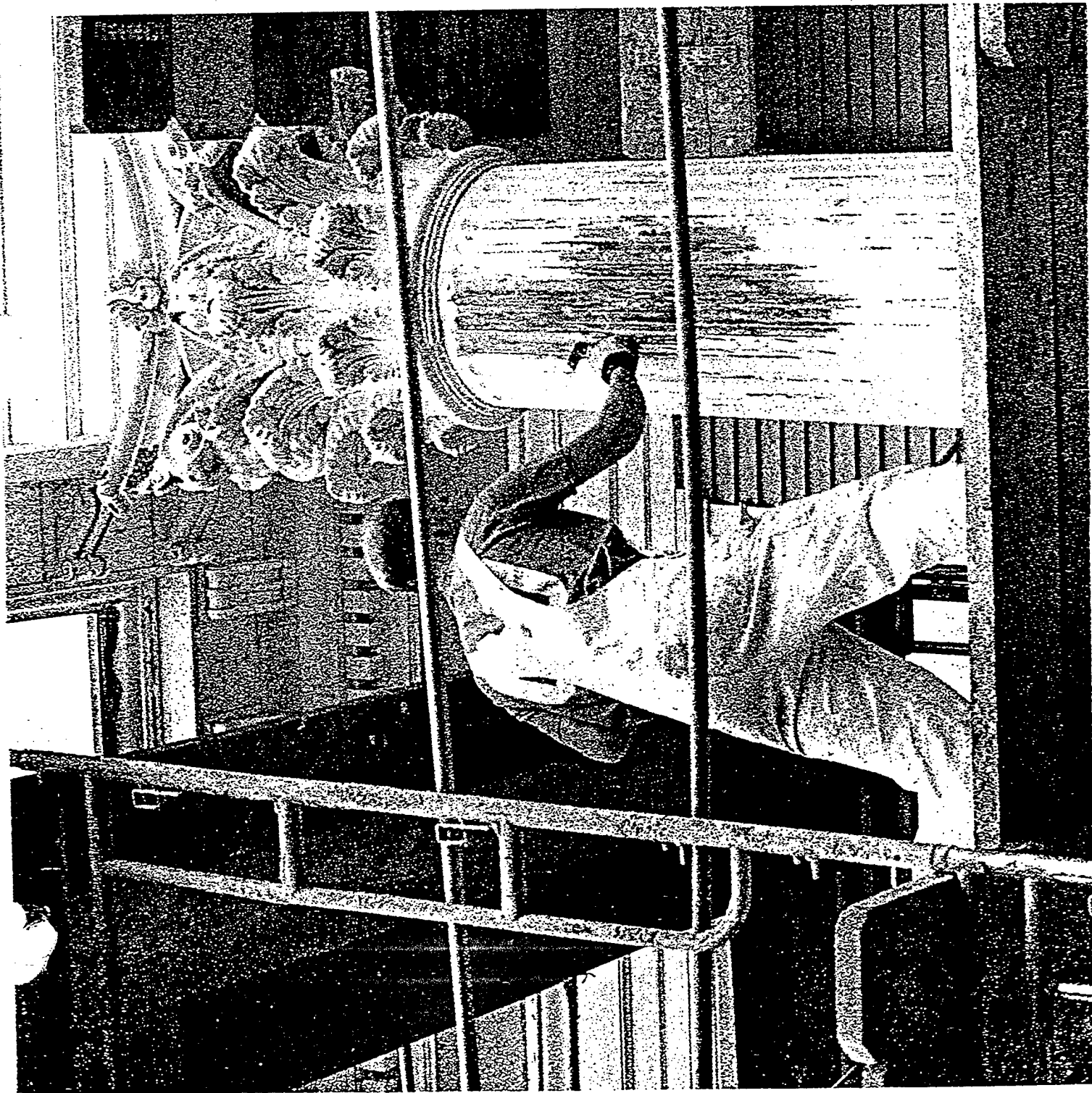

The Secretary of the Interior's
Standards for Rehabilitation &
*Illustrated Guidelines for
Rehabilitating Historic Buildings*

W. BROWN MORTON III • GARY L. HUME • KAY D. WEEKS • H. WARD JANDL

ANNE E. GRIMMER AND KAY D. WEEKS
Project Directors

U.S. Department of the Interior
National Park Service
Cultural Resources
Preservation Assistance Division
Washington, D.C.
1992

Contents

Acknowledgements	iii	Building Interior <i>Structural Systems</i>	47
Foreword	iv	Building Interior <i>Spaces, Features, and Finishes</i>	53
The Secretary of the Interior's Standards for Rehabilitation	v	Building Interior <i>Mechanical Systems</i>	61
Guidelines for Rehabilitating Historic Buildings	viii	Building Site	67
Building Exterior <i>Masonry</i>	1	Setting <i>District or Neighborhood</i>	75
Building Exterior <i>Wood</i>	9	Energy Conservation	83
Building Exterior <i>Architectural Metals</i>	17	New Additions to Historic Buildings	89
Building Exterior <i>Roofs</i>	23	Accessibility Considerations	95
Building Exterior <i>Windows</i>	29	Health and Safety Considerations	99
Building Exterior <i>Entrances and Porches</i>	35	<i>Appendix</i>	
Building Exterior <i>Storefronts</i>	41	Technical Guidance Publications	105
		NPS Regions and Washington Office Information	119

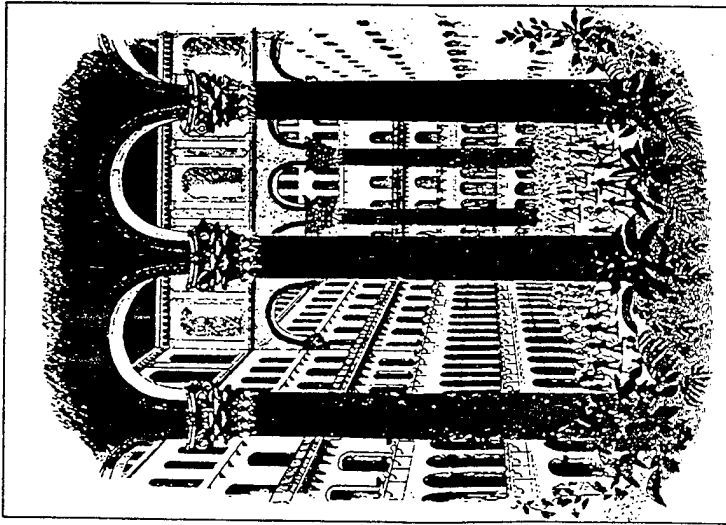

Photo Credit for Book Cover

Front/Back Covers: Residential rehabilitation, Seattle, Washington. © 1991. Mary Randlett.

Photo Credits for Chapter Heads

Building Exterior—Masonry. Jack E. Boucher, HABS.

Building Exterior—Wood. Jack E. Boucher, HABS.

Building Exterior—Architectural Metals.

Cervin Robinson, HABS.

Building Exterior—Roofs. Jack E. Boucher, HABS.

Building Exterior—Windows. Jack E. Boucher, HABS.

Building Exterior—Entrances and Porches.

Jack E. Boucher, HABS.

Building Exterior—Storefronts. Jack E. Boucher, HABS.

Building Interior—Structural Systems.

Cervin Robinson, HABS.

Building Interior—Spaces, Features and Finishes.

Brooks Photographers, HABS Collection.

Building Interior—Mechanical Systems.

National Park Service Files.

Building Site. Jack E. Boucher, HABS.

Setting (District or Neighborhood). Charles Ashton.

Energy Conservation. Laura A. Muckenfuss.

New Additions to Historic Buildings. Rodney Gary.

Accessibility Considerations. Department of Cultural Resources, Raleigh, North Carolina.

Health and Safety Considerations.

National Park Service Files.

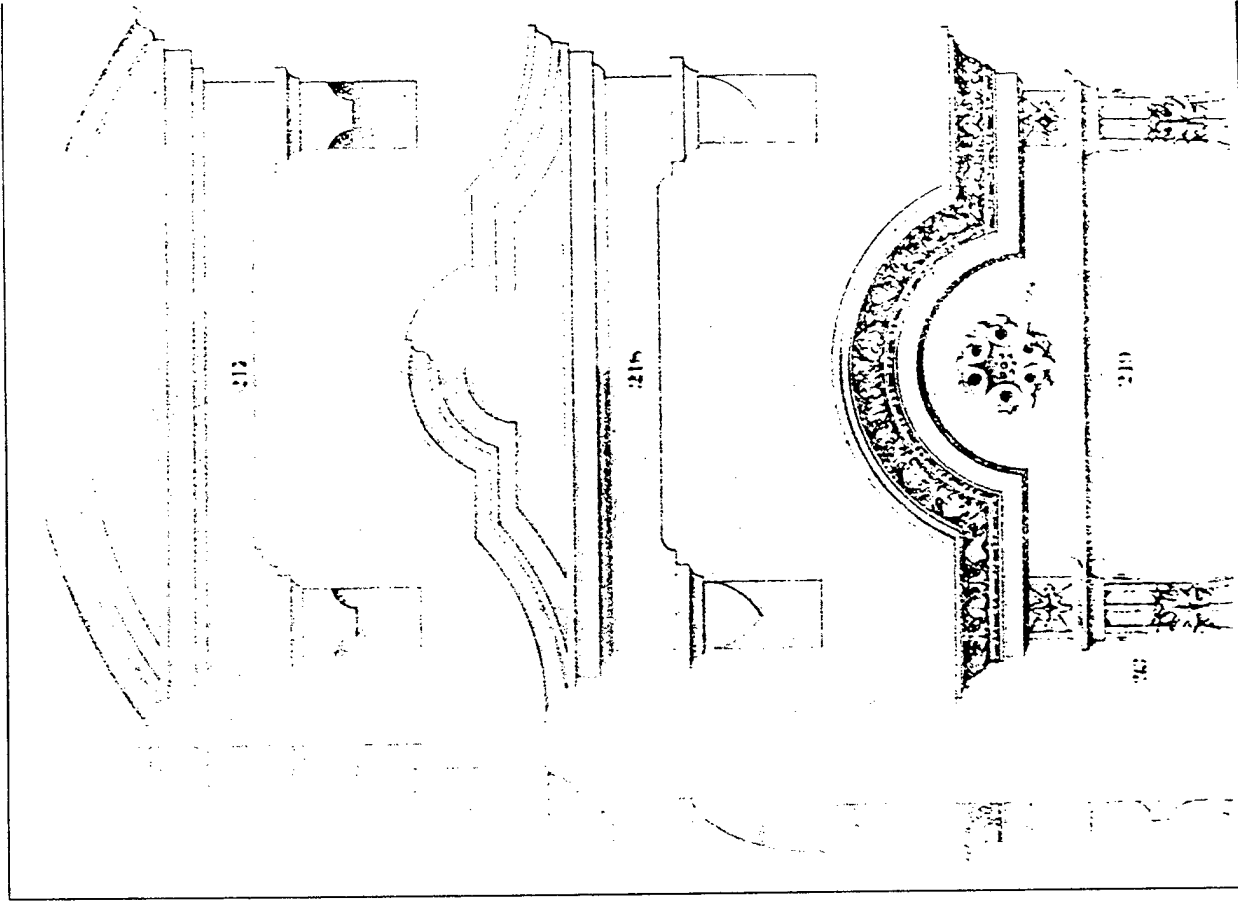

Acknowledgements

The illustrated version of the Standards and Guidelines for Rehabilitation was developed by the Technical Preservation Services Branch, Preservation Assistance Division of the National Park Service. Project Directors Anne E. Grimmer and Kay D. Weeks wish to thank those professional staff members who assisted in the book's preparation by providing technical review of the text, conducting photo research, and taking photographs. They include Michael J. Auer, Charles E. Fisher, Thomas C. Jester, Lauren G. Meier, ASLA, and Sharon C. Park, AIA. Tim Buehner prepared several technical drawings. Special thanks go to Jack E. Boucher and Catherine LaVoie of the Historic American Buildings Survey (HABS) who were especially helpful in conducting photographic research. Boucher's work appears throughout the book. Mary Randlett's photograph of ongoing rehabilitation work is featured on the cover.

All photographs and drawings included in this publication not individually credited have been selected from National Park Service Files.

This publication has been prepared pursuant to the National Historic Preservation Act of 1966, as amended, which directs the Secretary of the Interior to develop and make available information concerning historic properties. This publication has been prepared under the direction of H. Ward Jandl, Chief, Technical Preservation Services Branch, Preservation Assistance Division, National Park Service, P.O. Box 37127, Washington, D.C. 20013-7127, and comments on its usefulness may be directed to him at that address. Finally, the book is not copyrighted and can be reproduced without penalty. Normal procedures for credit to the National Park Service are appreciated.

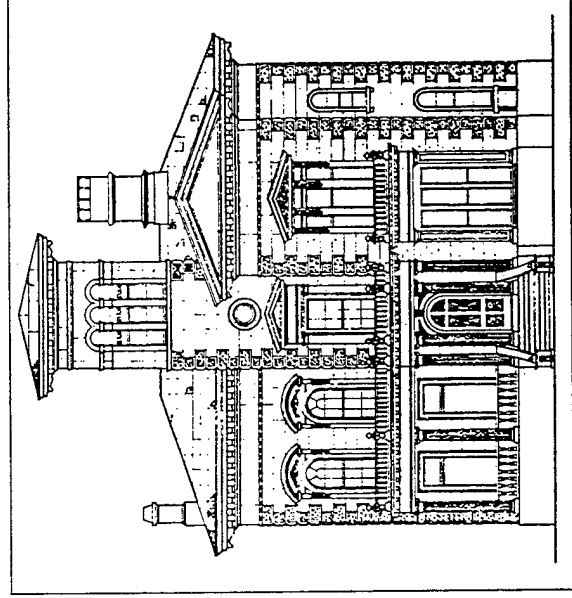

HABS Collection

Foreword

A banner year, 1991 marks the 75th anniversary of the National Park Service as well as 25 years of preservation achievements resulting from passage of the National Historic Preservation Act of 1966. Publication of the *illustrated* Guidelines for Rehabilitating Historic Buildings fittingly coincides with the celebration of this important Act that created our National Register programs and established a solid Federal/State partnership nationwide. Since 1966, over 800,000 properties have been placed in the National Register of Historic Places through the joint efforts of State Historic Preservation Offices, Federal agencies, Certified Local Governments, and the private sector. Over the past quarter century, historic preservation grants to the States for survey, planning and rehabilitation have amounted to nearly \$600 million, an investment totaling close to \$1.2 billion with the inclusion of matching non-Federal funds. Additionally, the Preservation Tax Incentives, now in their 14th year, have contributed to the rehabilitation of nearly 22,000 historic properties, representing an investment of almost \$15 billion in private funds.

The Secretary of the Interior's Standards are of particular relevance here because they have been used to determine the

appropriateness of work treatments for every grant-in-aid and Tax Act project over a 25-year period. By emphasizing repair over replacement, and limited rather than wholesale change to accommodate new uses, the Standards and their accompanying Guidelines seek to ensure the preservation of those qualities for which each property was listed in the National Register.

Finally, this illustrated version of the Guidelines for Rehabilitating Historic Buildings has been designed to enhance overall understanding of basic preservation principles. Showing specific examples of appropriate treatments as well as the consequences of inappropriate treatments is just another aspect of a sustained effort to encourage the most respectful approaches possible in rehabilitating our nation's irreplaceable historic properties.

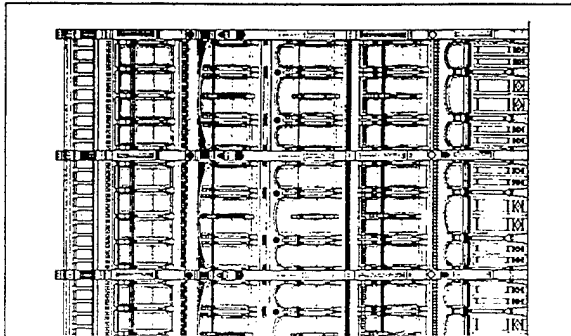

HABS Collection

The Secretary of the Interior's Standards for Rehabilitation

Introduction to the Standards

The Secretary of the Interior is responsible for establishing standards for all programs under Departmental authority and for advising Federal agencies on the preservation of historic properties listed in or eligible for listing in the National Register of Historic Places. In partial fulfillment of this responsibility, the Secretary of the Interior's Standards for Historic Preservation Projects have been developed to guide work undertaken on historic buildings; there are separate standards for acquisition, protection, stabilization, preservation, rehabilitation, restoration, and reconstruction. The Standards for Rehabilitation (codified in 36 CFR 67) comprise that section of the overall preservation project standards and addresses the most prevalent treatment. "Rehabilitation" is defined as "the process of returning a property to a state of utility, through repair or alteration, which makes possible an efficient contemporary use while preserving those portions and features of the property which are significant to its historic, architectural, and cultural values."

Initially developed by the Secretary of the Interior to determine the appropriateness of proposed project work on registered properties within the Historic Preservation Fund grant-in-aid program, the Standards for Rehabilitation have been widely used

over the years — particularly to determine if a rehabilitation qualifies as a Certified Rehabilitation for Federal purposes. In addition, the Standards have guided



Federal agencies in carrying out their historic preservation responsibilities for properties in Federal ownership or control; and State and local officials in reviewing

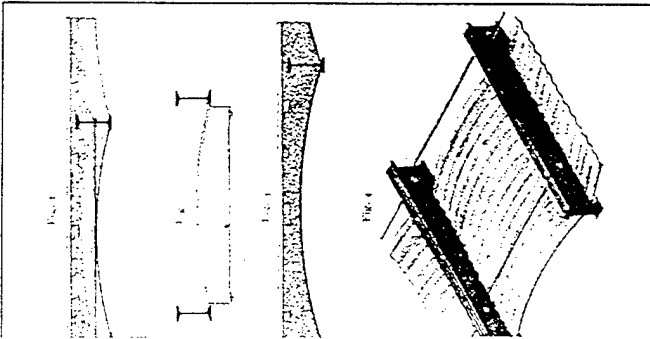

both Federal and nonfederal rehabilitation proposals. They have also been adopted by historic district and planning commissions across the country.

The intent of the Standards is to assist the long-term preservation of a property's significance through the preservation of historic materials and features. The Standards pertain to historic buildings of all materials, construction types, sizes, and occupancy and encompass the exterior and interior of the buildings. They also encompass related landscape features and the building's site and environment, as well as attached, adjacent, or related new construction. To be certified for Federal tax purposes, a rehabilitation project must be determined by the Secretary to be consistent with the historic character of the structure(s), and where applicable, the district in which it is located.

As stated in the definition, the treatment "rehabilitation" assumes that at least some repair or alteration of the historic building will be needed in order to provide for an efficient contemporary use; however, these repairs and alterations must not damage or destroy materials, features or finishes that are important in defining the building's historic character. For example, certain treatments — if improperly applied — may cause or accelerate physical deterioration

of the historic building. This can include using improper repointing or exterior masonry cleaning techniques, or introducing insulation that damages historic fabric. In almost all of these situations, use of these materials and treatments will result in a project that does not meet the Standards. Similarly, exterior additions that duplicate the form, material, and detailing of the structure to the extent that they compromise the historic character of the structure will fail to meet the Standards.

The Secretary of the Interior's Standards for Rehabilitation

The Standards (Department of Interior regulations, 36 CFR 67) pertain to historic buildings of all materials, construction types, sizes, and occupancy and encompass the exterior and the interior, related landscape features and the building's site and environment as well as attached, adjacent, or related new construction. The Standards are to be applied to specific rehabilitation projects in a reasonable manner, taking into consideration economic and technical feasibility.

1. A property shall be used for its historic purpose or be placed in a new use that requires minimal change to the defining characteristics of the building and its site and environment.

2. The historic character of a property shall be retained and preserved. The removal of historic materials or alteration of features and spaces that characterize a property shall be avoided.
3. Each property shall be recognized as a physical record of its time, place, and use. Changes that create a false sense of historical development, such as adding conjectural features or architectural elements from other buildings, shall not be undertaken.
4. Most properties change over time; those changes that have acquired historic significance in their own right shall be retained and preserved.
5. Distinctive features, finishes, and construction techniques or examples of craftsmanship that characterize a property shall be preserved.
6. Deteriorated historic features shall be repaired rather than replaced. Where the severity of deterioration requires replacement of a distinctive feature, the new feature shall match the old in design, color, texture, and other visual qualities and, where possible, materials. Replacement of missing features shall be substantiated by documentary, physical, or pictorial evidence.
7. Chemical or physical treatments, such as sandblasting, that cause damage to historic materials shall not be used. The surface cleaning of structures, if appropriate, shall be undertaken using the gentlest means possible.
8. Significant archeological resources affected by a project shall be protected and preserved. If such resources must be disturbed, mitigation measures shall be undertaken.
9. New additions, exterior alterations, or related new construction shall not destroy historic materials that characterize the property. The new work shall be differentiated from the old and shall be compatible with the massing, size, scale, and architectural features to protect the historic integrity of the property and its environment.
10. New additions and adjacent or related new construction shall be undertaken in such a manner that if removed in the future, the essential form and integrity of the historic property and its environment would be unimpaired.



Guidelines for Rehabilitating Historic Buildings

Introduction to the Guidelines

The Guidelines for Rehabilitating Historic Buildings were initially developed in 1977 to help property owners, developers, and Federal managers apply the Secretary of the Interior's "Standards for Rehabilitation" during the project planning stage by providing general design and technical recommendations. Unlike the Standards, the Guidelines are *not* codified as program

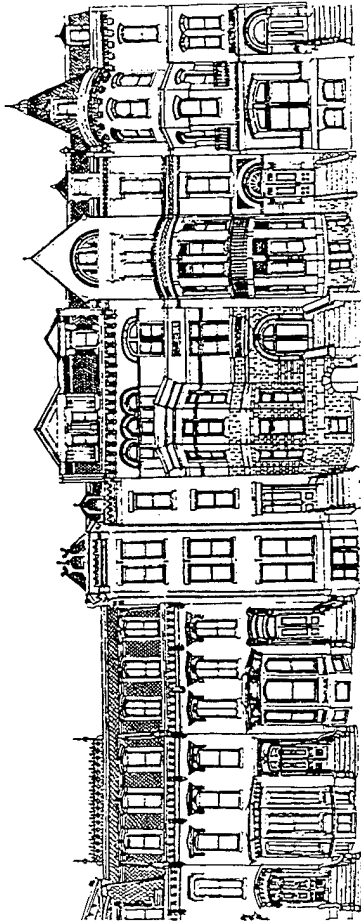

drawing: Nicholas Satterlee

cannot tell owners or developers which features of their own historic building are important in defining the historic character and must be preserved—although examples are provided in each section—or which features could be altered, if necessary, for the new use. This kind of careful case-by-case decision-making is best accomplished by seeking assistance from qualified historic preservation professionals in the planning stage of the project. Such professionals include architects, architectural historians, historians, archeologists, and others who are skilled in the preservation, rehabilitation, and restoration of the historic properties.

The Guidelines pertain to historic buildings of all sizes, materials, occupancy, and construction types; and apply to interior and exterior work as well as new exterior additions. Those approaches, treatments, and techniques that are consistent with the Secretary of the Interior's "Standards for Rehabilitation" are listed in the "Recommended" column on the left; those approaches, treatments, and techniques which could adversely affect a building's historic character are listed in the "Not Recommended" column on the right.

requirements. Together with the "Standards for Rehabilitation," they provide a model process for owners, developers, and Federal agency managers to follow.

The Guidelines are intended to assist in applying the Standards to projects generally; consequently, they are not meant to give case-specific advice or address exceptions or rare instances. For example, they

To provide clear and consistent guidance for owners, developers, and Federal agency managers to follow, the "Recommended" courses of action in each section are listed in order of historic preservation concerns so that a rehabilitation project may be successfully planned and completed — one that, first, assures the preservation of a building's important or "character-defining" architectural materials and features and, second, makes possible an efficient contemporary use. Rehabilitation guidance in each section begins with protection and maintenance, that work which should be maximized in every project to enhance overall preservation goals. Next, where some deterioration is present, repair of the building's historic materials and features is recommended. Finally, when deterioration is so extensive that repair is not possible, the most problematic area of work is considered: replacement of historic materials and features with new materials.

To further guide the owner and developer in planning a successful rehabilitation project, those complex design issues dealing with new use requirements such as alterations and additions are highlighted at the end of each section to underscore the need for particular sensitivity in these areas.

Identify, Retain, and Preserve

The guidance that is basic to the treatment of all historic buildings — *identifying, retaining, and preserving* the form and detailing of those architectural materials and features that are important in *defining the historic character* — is always listed first in the "Recommended" column. The parallel "Not Recommended" column lists the types of actions that are most apt to cause the diminution or even loss of the building's historic character. It should be remembered, however, that such loss of character is just as often caused by the cumulative effect of a series of actions that would seem to be minor interventions. Thus, the guidance in *all* of the "Not Recommended" columns must be viewed in that larger context, e.g., for the total impact on a historic building.

Protect and Maintain

After identifying those materials and features that are important and must be retained in the process of rehabilitation work, then *protecting and maintaining* them are addressed. Protection generally involves the least degree of intervention and is preparatory to other work. For example, protection includes the maintenance of historic material through treat-

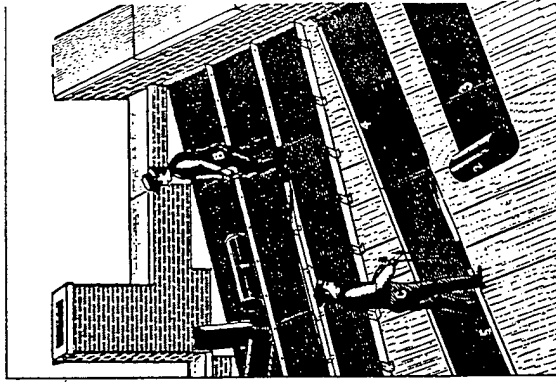

ments such as rust removal, caulking, limited paint removal, and re-application of protective coating; the cyclical cleaning of roof gutter systems; or installation of fencing, protective plywood, alarm systems and other temporary protective measures. Although a historic building will usually require more extensive work, an overall evaluation of its physical condition should always begin at this level.

Repair

Next, when the physical condition of character-defining materials and features warrants additional work *repairing* is recommended. Guidance for the repair of historic materials such as masonry, wood, and architectural metals again begins with the least degree of intervention possible such as patching, piecing-in, splicing, consolidating, or otherwise reinforcing or upgrading them according to recognized preservation methods. Repairing also includes the limited replacement in kind—or with compatible substitute material—of extensively deteriorated or missing *parts* of features when there are surviving prototypes (for example, brackets, dentils, steps, plaster, or portions of slate or tile roofing). Although using the same kind of material is always the preferred option, substitute material is acceptable if the form and design as well as the substitute material

itself convey the visual appearance of the remaining parts of the feature and finish.

Replace

Following repair in the hierarchy, guidance is provided for *replacing* an entire

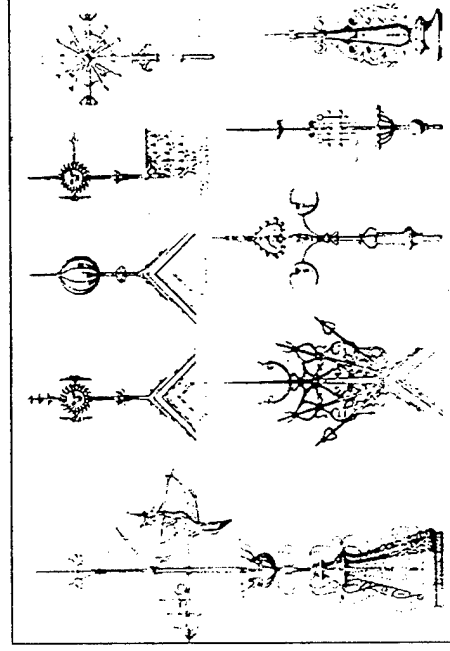

character-defining feature with new material because the level of deterioration or damage of materials precludes repair (for example, an exterior cornice; an interior staircase; or a complete porch or storefront). If the essential form and detailing are still evident so that the physical evidence can be used to re-establish the feature as an integral part of the rehabilitation project, then its replacement is appropriate. Like the guidance for repair, the preferred option is always replacement of the entire feature in kind, that is, with the

same material. Because this approach may not always be technically or economically feasible, provisions are made to consider the use of a compatible substitute material.

It should be noted that, while the National Park Service guidelines recommend the replacement of an entire character-defining feature under certain well-defined circumstances, they *never* recommend removal and replacement with new material of a feature that — although damaged or deteriorated — could reasonably be repaired and thus preserved.

Design for Missing Historic Features

When an entire interior or exterior feature is missing (for example, an entrance, or cast iron facade; or a principal staircase), it no longer plays a role in physically defining the historic character of the building unless it can be accurately recovered in form and detailing through the process of carefully documenting the historical appearance. Where an important architectural feature is missing, its recovery is always recommended in the guidelines as the *first* or preferred, course of action. Thus, if adequate historical, pictorial, and physical documentation exists so that the feature may be accurately reproduced, and if it is desirable to re-establish the feature as part of the building's historical appearance, then designing and constructing a

new feature based on such information is appropriate. However, a *second* acceptable option for the replacement feature is a

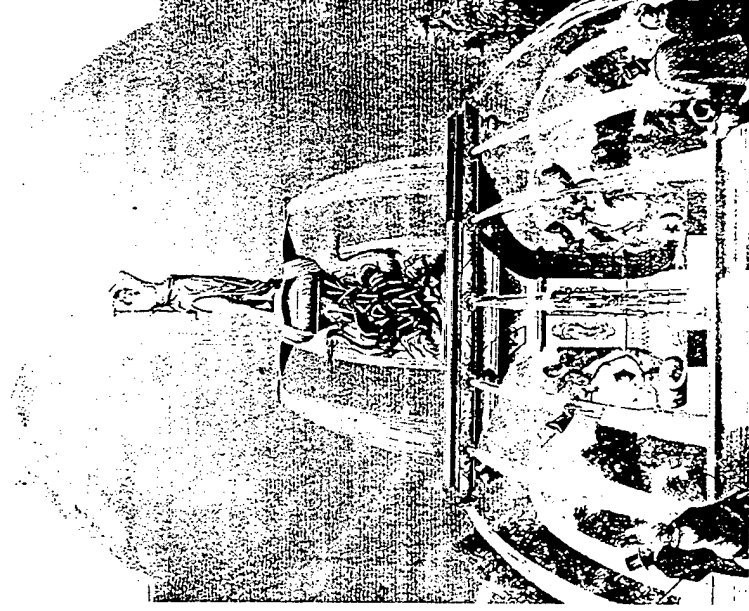

new design that is compatible with the remaining character-defining features of the historic building. The new design should always take into account the size, scale, and material of the historic building itself and, most importantly, should be clearly differentiated so that a false historical appearance is not created.

Alterations/Additions to Historic Buildings

Some exterior and interior alterations to historic building are generally needed to assure its continued use, but it is most important that such alterations do not radically change, obscure, or destroy character-defining spaces, materials, features, or finishes. Alterations may include providing additional parking space on an existing historic building site; cutting new entrances or windows on secondary elevations; inserting an additional floor; installing an entirely new mechanical system; or creating an atrium or light well. Alteration may also include the selective removal of buildings or other features of the environment or building site that are intrusive and therefore detract from the overall historic character.

The construction of an exterior addition to a historic building may seem to be essential for the new use, but it is emphasized in the guidelines that such new additions should be avoided, if possible, and considered *only* after it is determined that those needs cannot be met by altering secondary, i.e., non character-defining interior spaces. If, after a thorough evaluation of interior solutions, an exterior addition is still judged to be the only viable alternative, it should be designed and constructed to be clearly differentiated from the historic

building and so that the character-defining features are not radically changed, obscured, damaged, or destroyed.

Additions to historic buildings are referenced within specific sections of the guidelines such as Site, Roof, Structural Systems, etc., but are also considered in more detail in a separate section, New Additions to Historic Buildings.

Energy Conservation/Accessibility Considerations/Health and Safety Code Considerations

These sections of the rehabilitation guidance address work done to meet accessibility requirements and health and safety code requirements; or retrofitting measures to conserve energy. Although this work is quite often an important aspect of rehabilitation projects, it is usually not a part of the overall process of protecting or repairing character-defining features; rather, such work is assessed for its potential negative impact on the building's historic character. For this reason, particular care must be taken not to radically change, obscure, damage, or destroy character-defining materials or features in the process of undertaking work to meet various code requirements.

Building Exterior

Masonry

- BRICK
- STONE
- TERRA COTTA
- CONCRETE
- ADOBE
- STUCCO
- MORTAR

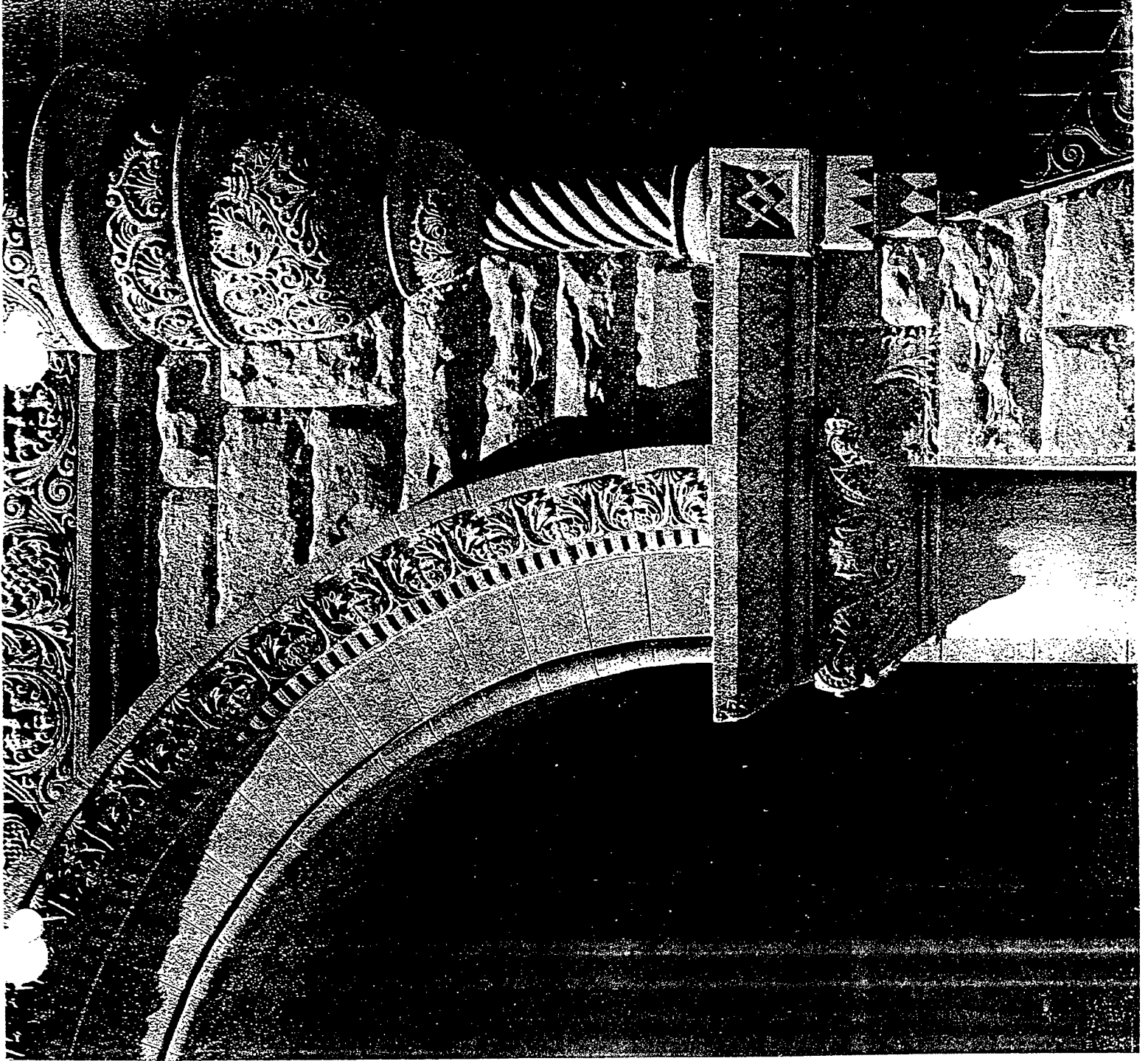

Building Exterior

Masonry

The longevity and appearance of a masonry wall is dependent upon the size of the individual units and the mortar.

Stone is one of the more lasting of masonry building materials and has been used throughout the history of American building construction. The kinds of stone most commonly encountered on historic buildings in the U.S. include various types of sandstone, limestone, marble, granite, slate and fieldstone. Brick varied considerably in size and quality. Before 1870, brick clays were pressed into molds and were often unevenly fired. The quality of brick depended on the type of clay available and the brick-making techniques; by the 1870s—with the perfection of an extrusion process—bricks became more uniform and durable. Terra cotta is also a kiln-dried clay product popular from the late 19th century until the 1930s. The development of the steel-frame office buildings in the early 20th century contributed to the widespread use of architectural terra cotta. Adobe, which consists of sun-dried earthen bricks, was one of the earliest permanent building materials used in the U.S., primarily in the Southwest where it is still popular.

Mortar is used to bond together masonry units. Historic mortar was generally quite soft, consisting primarily of lime and sand with other additives. After 1880, portland cement was usually added resulting in a more rigid and non-absorbing mortar. Like historic mortar, early stucco coatings were also heavily lime-based, increasing in hardness with the addition of portland cement in the late 19th century. Concrete has a long history, being variously made of tabby, volcanic ash and, later, of natural hydraulic cements, before the introduction of portland cement in the 1870s. Since then, concrete has also been used in its precast form.

While masonry is among the most durable of historic building materials, it is also very susceptible to damage by improper maintenance or repair techniques and harsh or abrasive cleaning methods.

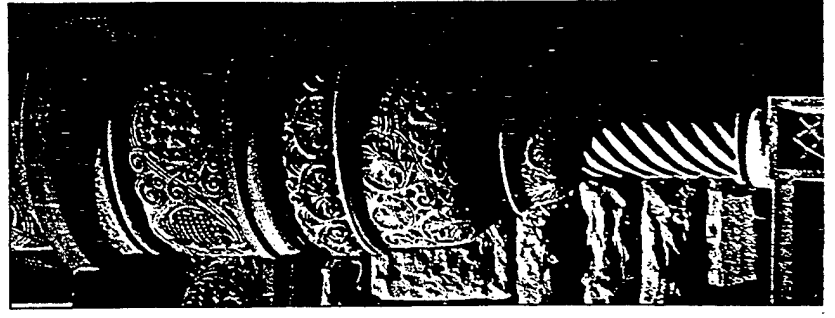

Recommended

Identify, retain, and preserve

Identifying, retaining, and preserving masonry features that are important in defining the overall historic character of the building such as walls, brackets, railings, cornices, window architraves, door pediments, steps, and columns and details such as tooling and bonding patterns, coatings, and color.

Not Recommended

Removing or radically changing masonry features which are important in defining the overall historic character of the building so that, as a result, the character is diminished.

Replacing or rebuilding a major portion of exterior masonry walls that could be repaired so that, as a result, the building is no longer historic and is essentially new construction.

Applying paint or other coatings such as stucco to masonry that has been historically unpainted or uncoated to create a new appearance.

Removing paint from historically painted masonry.

Radically changing the type of paint or coating or its color.

Protect and maintain

Protecting and maintaining masonry by providing proper drainage so that water does not stand on flat, horizontal surfaces or accumulate in curved decorative features.

Cleaning masonry only when necessary to halt deterioration or remove heavy soiling.

Carrying out masonry surface cleaning tests after it has been determined that such cleaning is appropriate. Tests should be observed over a sufficient period of time so that both the immediate and the long range effects are known to enable selection of the gentlest method possible.

Cleaning masonry surfaces when they are not heavily soiled to create a new appearance, thus needlessly introducing chemicals or moisture into historic materials.

Cleaning masonry surfaces without testing or without sufficient time for the testing results to be of value.

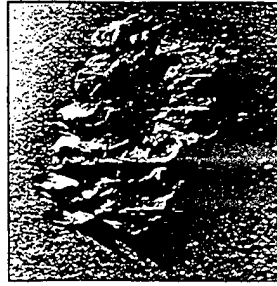
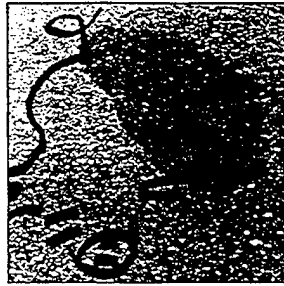
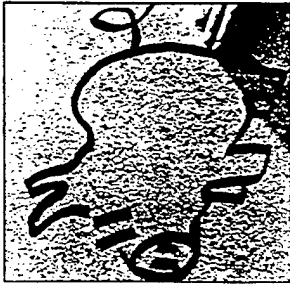

Graffiti applied with a felt-tipped marker to polished granite is being removed with a mixture of solvents. The slight ghost outline was successfully eliminated using the same solvent mixture in a clay poultice, followed by a thorough detergent and water rinse.

When this brick wall was sandblasted, a downspout (since removed) protected the original smooth surface of the center strip from damage.

Photo: The Old-House Journal

Recommended

Cleaning masonry surfaces with the gentlest method possible, such as low pressure water and detergents, using natural bristle brushes.

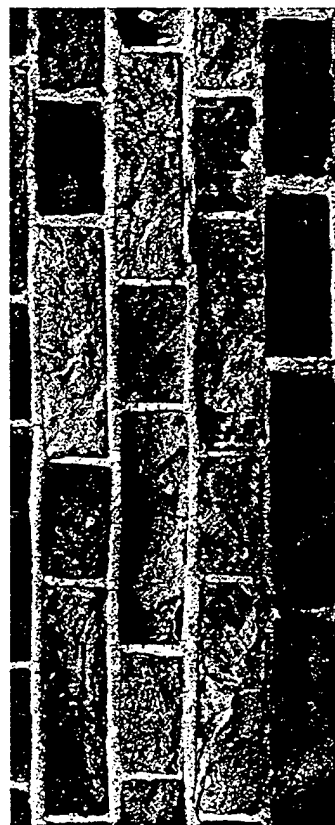

Photo: Jack E. Boucher, HABS

Too hard and inflexible a mortar has caused this soft, 18th century brick to spall.

Inspecting painted masonry surfaces to determine whether repainting is necessary.

Removing damaged or deteriorated paint only to the next sound layer using the gentlest method possible (e.g., handscraping) prior to repainting.

Applying compatible paint coating systems following proper surface preparation.

Repainting with colors that are historically appropriate to the building and district.

Not Recommended

Sandblasting brick or stone surfaces using dry or wet grit or other abrasives. These methods of cleaning permanently erode the surface of the material and accelerate deterioration.

Using a cleaning method that involves water or liquid chemical solutions when there is any possibility of freezing temperatures.

Cleaning with chemical products that will damage masonry, such as using acid on limestone or marble, or leaving chemicals on masonry surfaces.

Applying high pressure water cleaning methods that will damage historic masonry and the mortar joints.

Removing paint that is firmly adhering to, and thus protecting, masonry surfaces.

Using methods of removing paint which are destructive to masonry, such as sandblasting, application of caustic solutions, or high pressure waterblasting.

Failing to follow manufacturers' product and application instructions when repainting masonry.

Using new paint colors that are inappropriate to the historic building and district.

Recommended

Evaluating the overall condition of the masonry to determine whether more than protection and maintenance are required, that is, if repairs to the masonry features will be necessary.

Repair

Repairing masonry walls and other masonry features by repointing the mortar joints where there is evidence of deterioration such as disintegrating mortar, cracks in mortar joints, loose bricks, damp walls, or damaged plasterwork.

Not Recommended

Failing to undertake adequate measures to assure the protection of masonry features.

Removing nondeteriorated mortar from sound joints, then repointing the entire building to achieve a uniform appearance.

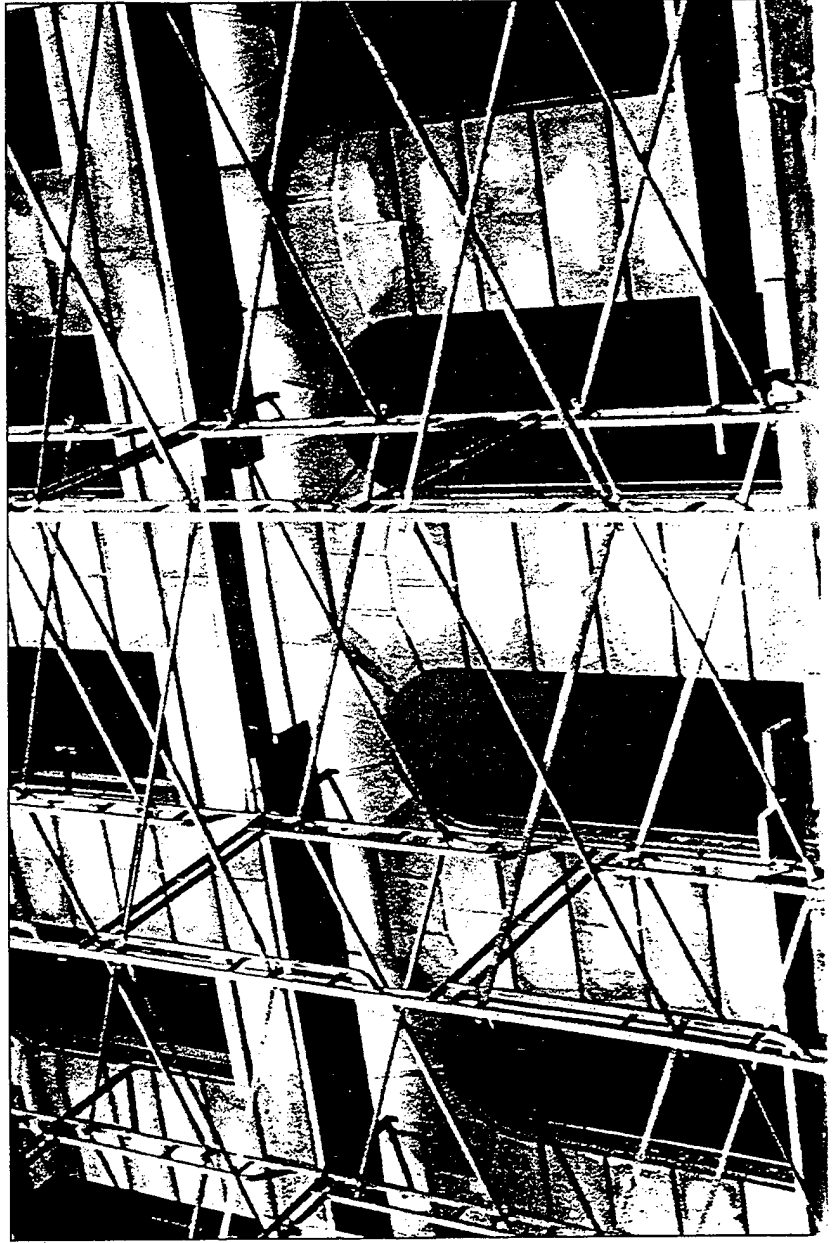

Composite patching with a cementitious mixture is being used to repair eroded areas of this sandstone facade.

Moisture from a faulty roof and drainage system has been trapped inside this limestone cornice by a waterproof coating, causing severe damage to the stone.



Recommended

Removing deteriorated mortar by carefully hand-raking the joints to avoid damaging the masonry.

Duplicating old mortar in strength, composition, color, and texture.

Duplicating old mortar joints in width and in joint profile.

Repairing stucco by removing the damaged material and patching with new stucco that duplicates the old in strength, composition, color, and texture.

Using mud plaster as a surface coating over unfired, unstabilized adobe because the mud plaster will bond to the adobe.

Not Recommended

Using electric saws and hammers rather than hand tools to remove deteriorated mortar from joints prior to repointing.

Repointing with mortar of high portland cement content (unless it is the content of the historic mortar). This can often create a bond that is stronger than the historic material and can cause damage as a result of the differing coefficient of expansion and the differing porosity of the material and the mortar.

Repointing with a synthetic caulking compound.

Using a "scrub" coating technique to repoint instead of traditional repointing methods.

Changing the width or joint profile when repointing.

Removing sound stucco; or repairing with new stucco that is stronger than the historic material or does not convey the same visual appearance.

Applying cement stucco to unfired, unstabilized adobe. Because the cement stucco will not bond properly, moisture can become entrapped between materials, resulting in accelerated deterioration of the adobe.



Photo: Jack E. Boucher, HABS

Excessive moisture has damaged not only the stuccoed wall surface, but also the brick substrate.

Recommended

Cutting damaged concrete back to remove the source of deterioration (often corrosion on metal reinforcement bars). The new patch must be applied carefully so it will bond satisfactorily with, and match, the historic concrete.

Repairing masonry features by patching, piecing-in, or consolidating the masonry using recognized preservation methods. Repair may also include the limited replacement in kind—or with compatible substitute material—of those extensively deteriorated or missing parts of masonry features when there are surviving prototypes such as terra-cotta brackets or stone balusters.

Applying new or non-historic surface treatments such as water-repellent coatings to masonry only after repointing and only if masonry repairs have failed to arrest water penetration problems.

Not Recommended

Patching concrete without removing the source of deterioration.

Replacing an entire masonry feature such as a cornice or balustrade when repair of the masonry and limited replacement of deteriorated or missing parts are appropriate.

Using a substitute material for the replacement part that does not convey the visual appearance of the surviving parts of the masonry feature or that is physically or chemically incompatible.

Applying waterproof, water repellent, or non-historic coating such as stucco to masonry as a substitute for repointing and masonry repairs. Coatings are frequently unnecessary, expensive, and may change the appearance of historic masonry as well as accelerate its deterioration.

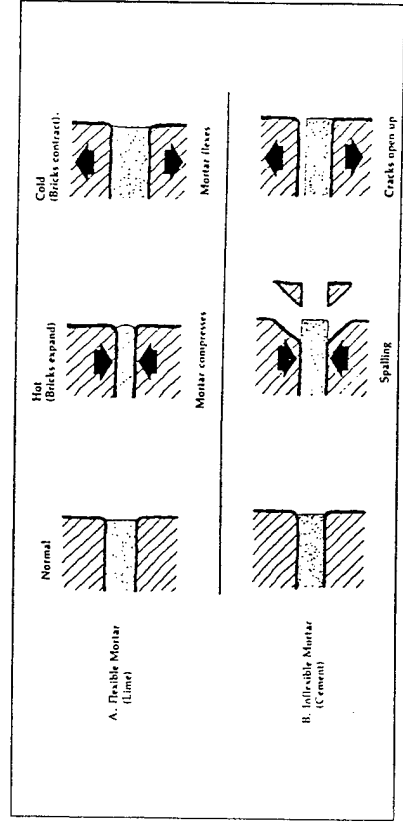

Flexible mortar expands and contracts with temperature changes. Bricks bonded by inflexible mortar tend to spall at the edges in hot weather and separate from the mortar when it is cold. Temperature fluctuations result in cracks which permit water to enter, causing additional deterioration.

Recommended

Replace

Replacing in kind an entire masonry feature that is too deteriorated to repair—if the overall form and detailing are still evident—using the physical evidence as a model to reproduce the feature. Examples can include large sections of a wall, a cornice, balustrade, column, or stairway. If using the same kind of material is not technically or economically feasible, then a compatible substitute material may be considered.

Not Recommended

Removing a masonry feature that is unrepairable and not replacing it; or replacing it with a new feature that does not convey the same visual appearance.

Design for Missing Historic Features

The following work is highlighted to indicate that it represents the particularly complex technical or design aspects of rehabilitation projects and should only be considered after the preservation concerns listed above have been addressed.

Recommended

Designing and installing a new masonry feature such as steps or a door pediment when the historic feature is completely missing. It may be an accurate restoration using historical, pictorial, and physical documentation; or be a new design that is compatible with the size, scale, material, and color of the historic building.

Not Recommended

Creating a false historical appearance because the replaced masonry feature is based on insufficient historical, pictorial, and physical documentation.

Introducing a new masonry feature that is incompatible in size, scale, material and color.



Coving—the hollowing out of an adobe wall just above grade—may be caused by standing rainwater, rainwater splash-up from the ground, or by salts deposited in the adobe by moisture evaporation. This adobe wall is being patched in the traditional manner with adobe mud.

Building Exterior

Wood

CLAPBOARD
WEATHERBOARD
SHINGLES AND
OTHER WOODEN SIDING
AND DECORATIVE ELEMENTS

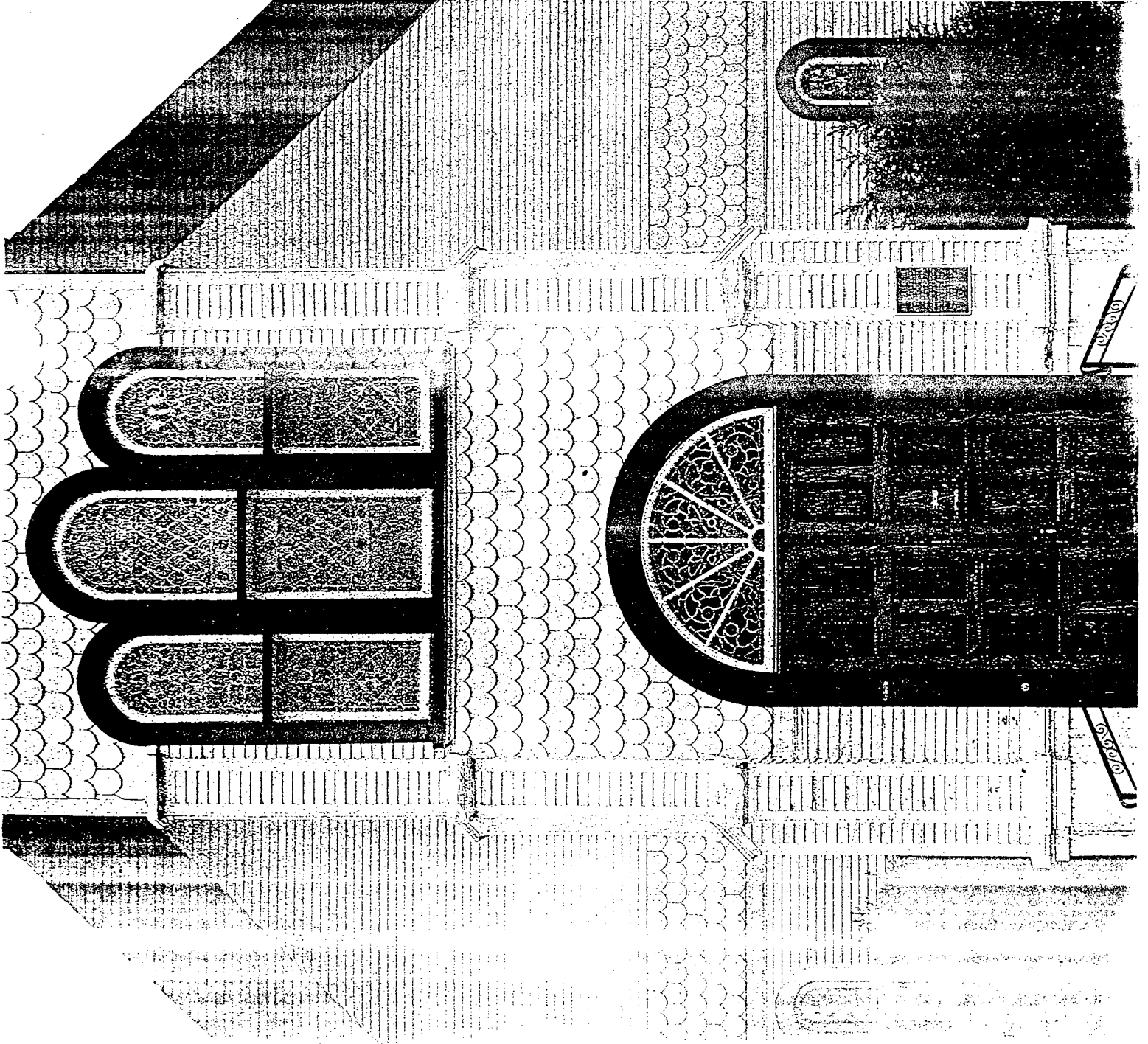

Building Exterior

Wood

Because it can be easily shaped by sawing, planing, carving, and gouging, wood is used for architectural features such as clapboard, cornices, brackets, entablatures, shutters, columns and balustrades. These wooden features, both functional and decorative, may be important in defining the historic character of the building and thus their retention, protection, and repair are important in rehabilitation projects.

Wood has played a central role in American buildings during every period and in every style. Whether as structural membering, exterior cladding, roofing, interior finishes, or decorative features, wood is frequently an essential component of historic and older buildings.

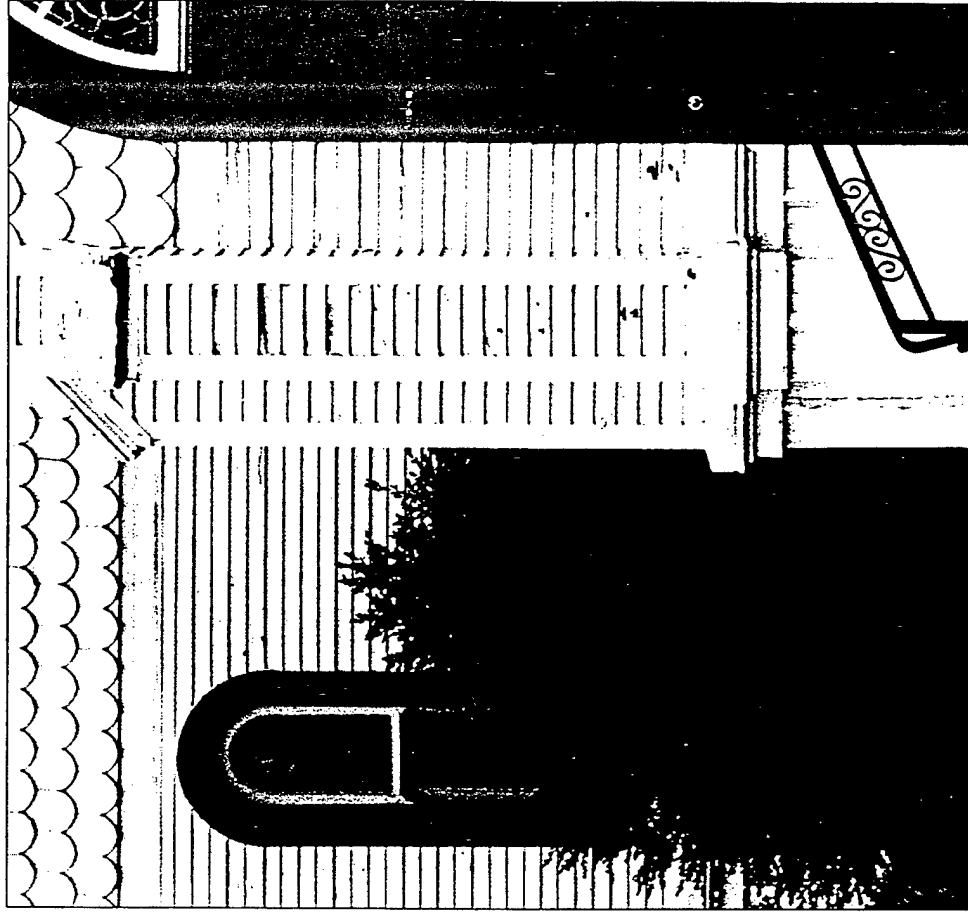

Recommended

Identify, retain, and preserve

Identifying, retaining, and preserving wood features that are important in defining the overall historic character of the building such as siding, cornices, brackets, window architraves, and doorway pediments; and their paints, finishes, and colors.

Due to lack of maintenance, the paint has peeled to bare wood. In order to survive, this cornice will need to be scraped, sanded, and repainted together with other essential repairs.



Protect and maintain

Protecting and maintaining wood features by providing proper drainage so that water is not allowed to stand on flat, horizontal surfaces or accumulate in decorative features.

Applying chemical preservatives to wood features such as beam ends or outriggers that are exposed to decay hazards and are traditionally unpainted.

Not Recommended

Removing or radically changing wood features which are important in defining the overall historic character of the building so that, as a result, the character is diminished.

Removing a major portion of the historic wood from a facade instead of repairing or replacing only the deteriorated wood, then reconstructing the facade with new material in order to achieve a uniform or "improved" appearance.

Radically changing the type of finish or its color or accent scheme so that the historic character of the exterior is diminished.

Stripping historically painted surfaces to bare wood, then applying clear finishes or stains in order to create a "natural look."

Stripping paint or varnish to bare wood rather than repairing or reapplying a special finish, i.e., a grained finish to an exterior wood feature such as a front door.

Failing to identify, evaluate, and treat the causes of wood deterioration, including faulty flashing, leaking gutters, cracks and holes in siding, deteriorated caulking in joints and seams, plant material growing too close to wood surfaces, or insect or fungus infestation.

Using chemical preservatives such as creosote which can change the appearance of wood features unless they were used historically.

Recommended

Retaining coatings such as paint that help protect the wood from moisture and ultraviolet light. Paint removal should be considered only where there is paint surface deterioration and as part of an overall maintenance program which involves repainting or applying other appropriate protective coatings.

Inspecting painted wood surfaces to determine whether repainting is necessary or if cleaning is all that is required.

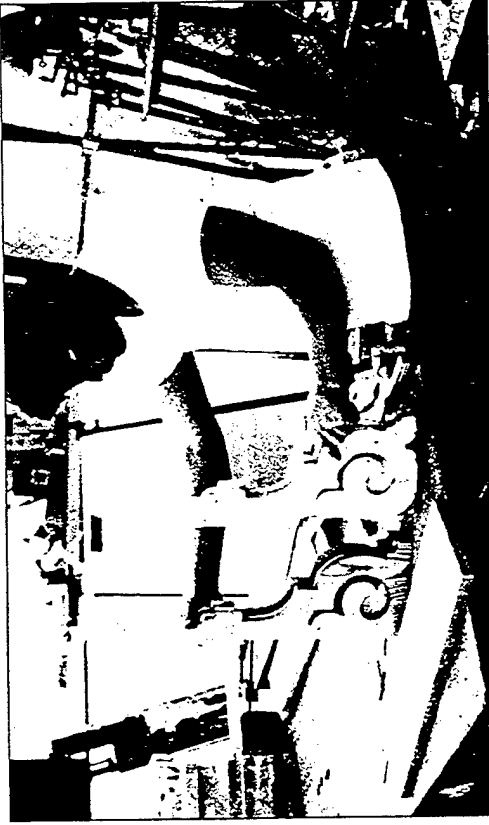

If a character-defining feature is missing, it should be replaced with a matching feature. This shop artisan used traditional tools to replicate a missing porch bracket; after the new bracket is painted, both original and duplicate will be installed on-site.

Not Recommended

Stripping paint or other coatings to reveal bare wood, thus exposing historically coated surfaces to the effects of accelerated weathering.

Removing paint that is firmly adhering to, and thus, protecting wood surfaces.

Replacing an entire wood feature such as a cornice or wall when repair of the wood and limited replacement of deteriorated or missing parts are appropriate.

Using substitute material for the replacement part that does not convey the visual appearance of the surviving parts of the wood feature or that is physically or chemically incompatible.

Using destructive paint removal methods such as a propane or butane torches, sandblasting or waterblasting. These methods can irreversibly damage historic woodwork.

Removing damaged or deteriorated paint to the next sound layer using the gentlest method possible (handscraping and handsanding), then repainting.

Deteriorated clapboards are being selectively replaced, thereby maximizing retention of the historic siding.



Recommended

Using with care electric hot-air guns on decorative wood features and electric heat plates on flat wood surfaces when paint is so deteriorated that total removal is necessary prior to repainting.

Using chemical strippers primarily to supplement other methods such as handscraping, hand sanding and the above-recommended thermal devices. Detachable wooden elements such as shutters, doors, and columns may—with the proper safeguards—be chemically dip-stripped.

Applying compatible paint coating systems following proper surface preparation.

Not Recommended

Using thermal devices improperly so that the historic woodwork is scorched.

Failing to neutralize the wood thoroughly after using chemicals so that new paint does not adhere.

Allowing detachable wood features to soak too long in a caustic solution so that the wood grain is raised and the surface roughened.

Failing to follow manufacturers' product and application instructions when repainting exterior woodwork.

Recommended

Repainting with colors that are appropriate to the historic building and district.

Not Recommended

Using new colors that are inappropriate to the historic building or district.

Evaluating the overall condition of the wood to determine whether more than protection and maintenance are required, that is, if repairs to wood features will be necessary.

Failing to undertake adequate measures to assure the protection of wood features.

Repair

Repairing wood features by patching, piecing-in, consolidating, or otherwise reinforcing the wood using recognized preservation methods. Repair may also include the limited replacement in kind—or with compatible substitute material—of those extensively deteriorated or missing parts of features where there are surviving prototypes such as brackets, molding, or sections of siding.

Replacing an entire wood feature such as a cornice or wall when repair of the wood and limited replacement of deteriorated or missing parts are appropriate.

Using substitute material for the replacement part that does not convey the visual appearance of the surviving parts of the wood feature or that is physically or chemically incompatible.

Replace

Replacing in kind an entire wood feature that is too deteriorated to repair—if the overall form and detailing are still evident—using the physical evidence as a model to reproduce the feature. Examples of wood features include a cornice, entablature or balustrade. If using the same kind of material is not technically or economically feasible, then a compatible substitute material may be considered.

Removing an entire wood feature that is unrepairable and not replacing it; or replacing it with a new feature that does not convey the same visual appearance.

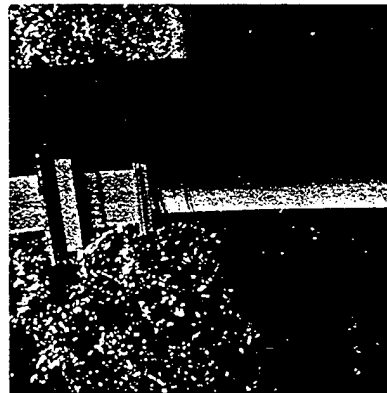
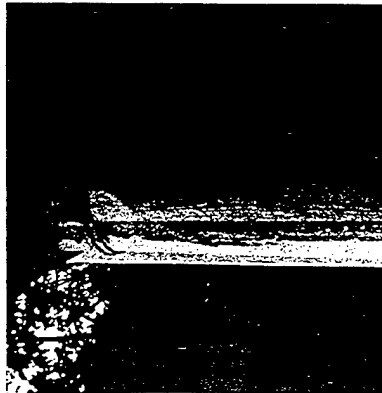

To replace deteriorated portions of the column, strips of new wood were milled to conform to the shape and appearance of the old column framework, glued in place, then back-primed and painted.

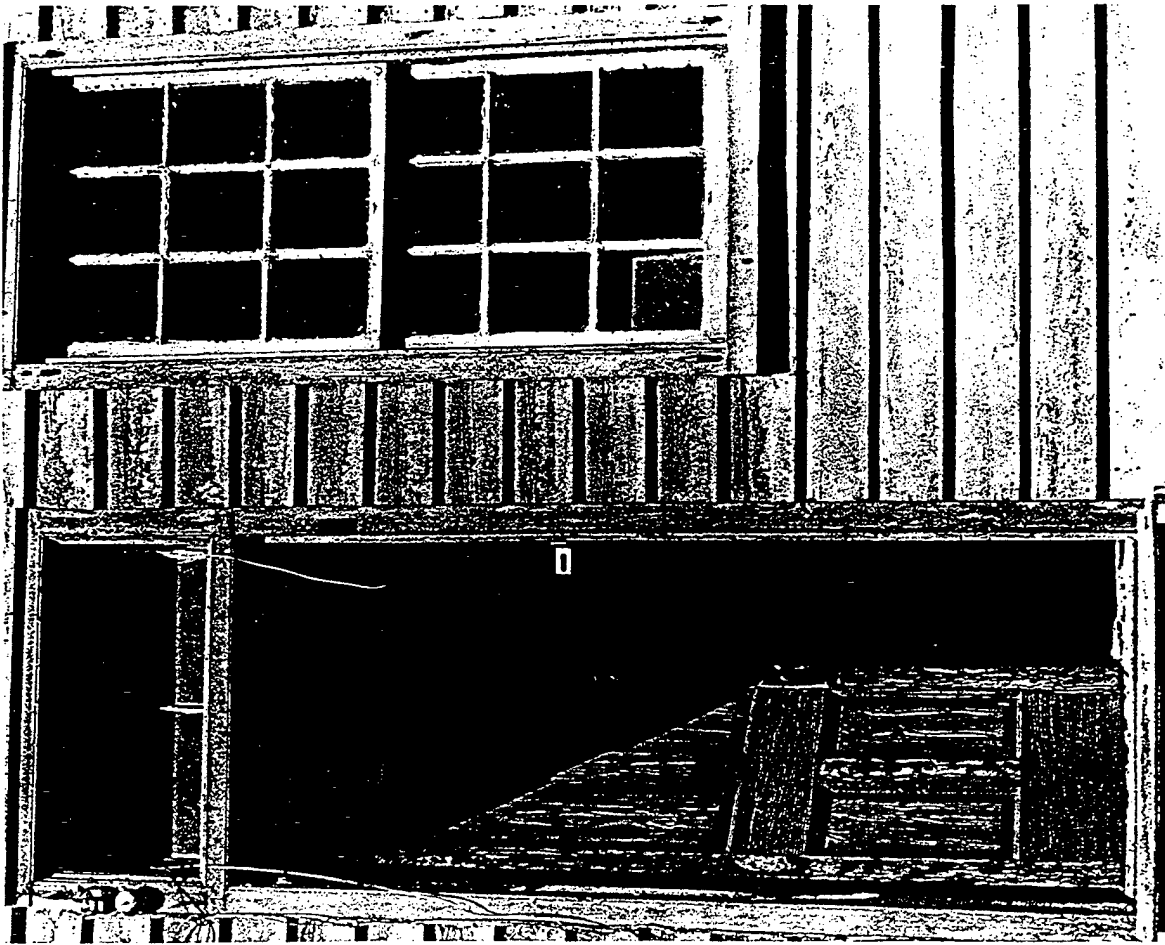

Design for Missing Historic Features

The following work is highlighted to indicate that it represents the particularly complex technical or design aspects of rehabilitation projects and should only be considered after the preservation concerns listed above have been addressed.

Recommended

Designing and installing a new wood feature such as a cornice or doorway when the historic feature is completely missing. It may be an accurate restoration using historical, pictorial, and physical documentation; or be a new design that is compatible with the size, scale, material, and color of the historic building.

Not Recommended

Creating a false historical appearance because the replaced wood feature is based on insufficient historical, pictorial, and physical documentation.

Introducing a new wood feature that is incompatible in size, scale, material and color.

As protection from the extremes of weather, paint should be re-applied to exterior wood on a regular basis.

Building Exterior

Architectural Metals

CAST IRON

STEEL

PRESSED TIN

COPPER

ALUMINUM

ZINC

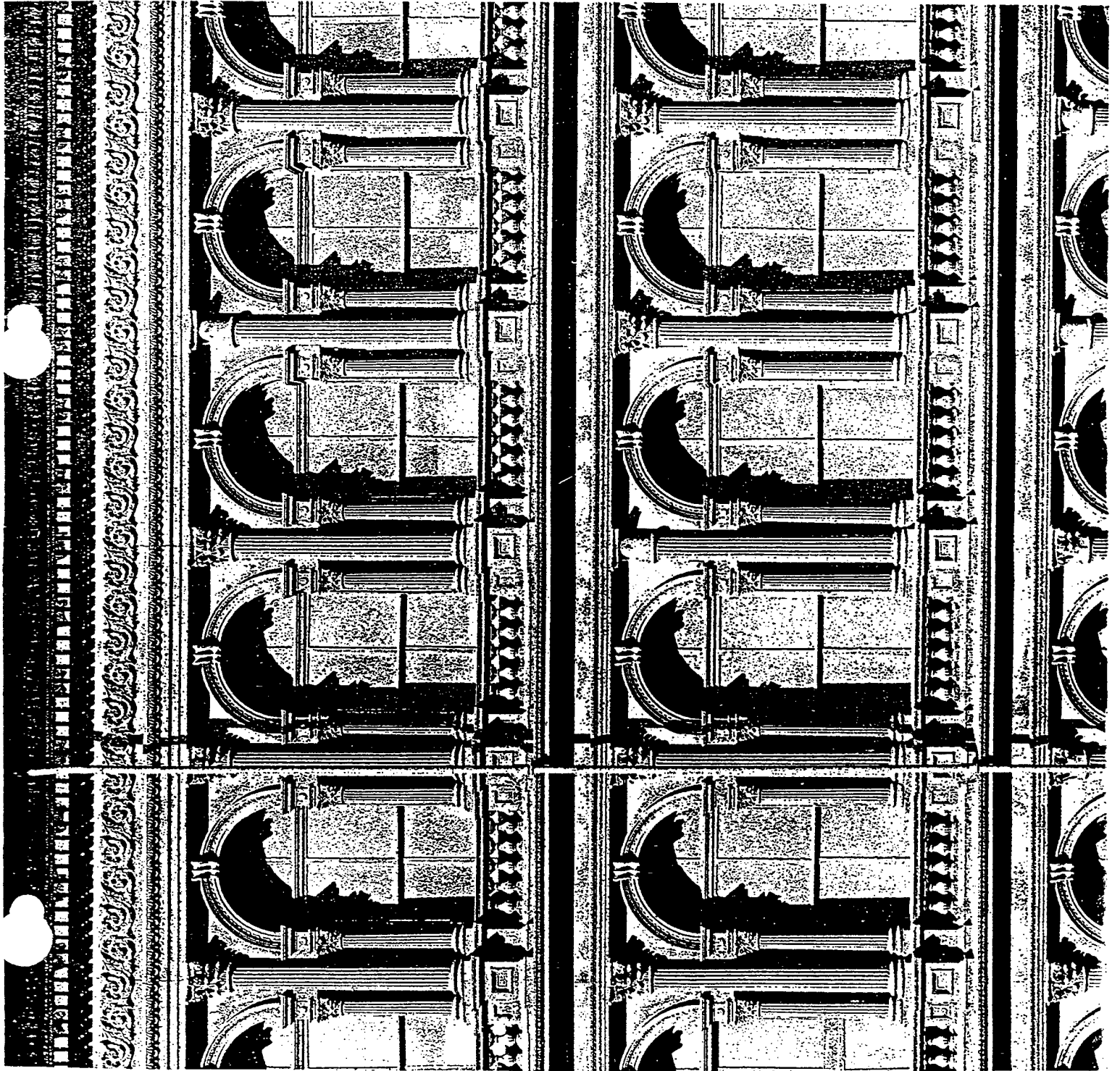

Building Exterior

Architectural Metals

Architectural metal features—such as cast iron facades, porches, and steps; sheet metal cornices, siding, roofs, roof cresting and storefronts; and cast or rolled metal doors, window sash, entablatures, and hardware—are often highly decorative and may be important in defining the overall historic character of the building.

Metals commonly used in historic buildings include lead, tin, zinc, copper, bronze, brass, iron, steel, and to a lesser extent, nickel alloys, stainless steel and aluminum. Historic metal building components were often created by highly skilled, local artisans, and by the late 19th century, many of these components were prefabricated and readily available from catalogs in standardized sizes and designs.

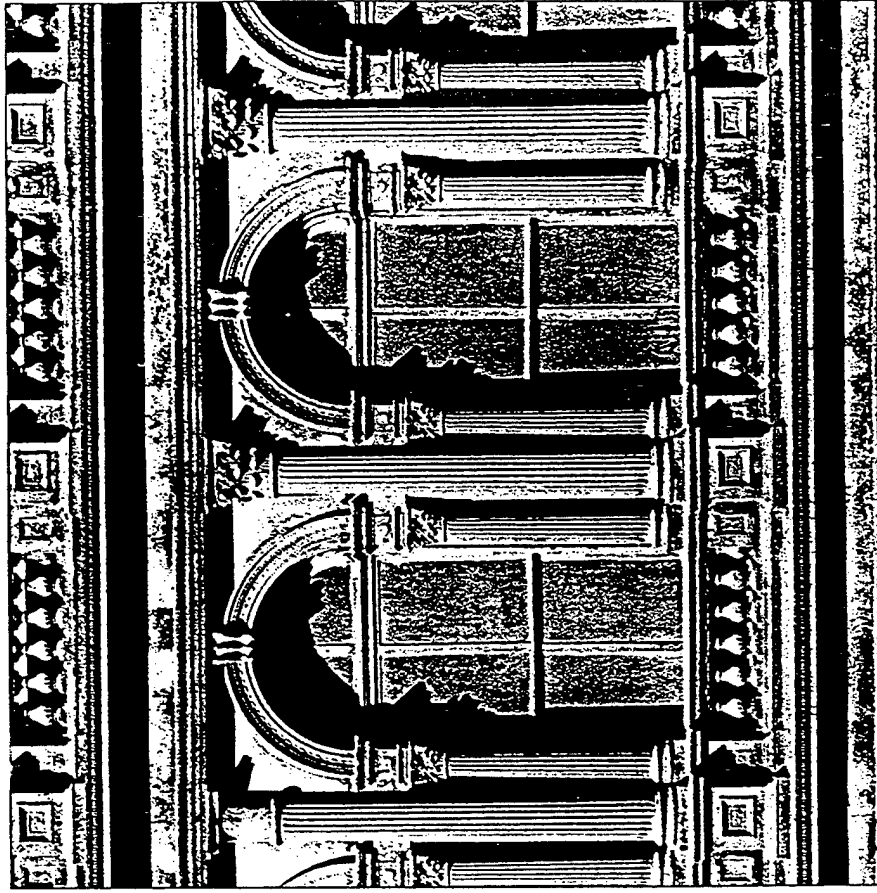

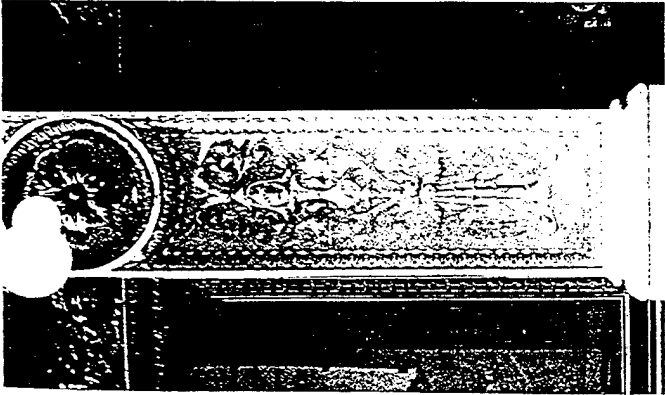

The decorative cast-iron storefront column was sandblasted in order to remove flaking paint and rust prior to repainting. Unlike soft metals such as copper and tin, which are damaged by abrasive cleaning, sandblasting is an appropriate method for cleaning cast iron, a very hard metal.

Recommended

Identify, retain, and preserve

Identifying, retaining, and preserving architectural metal features such as columns, capitals, window hoods, or stairways that are important in defining the overall historic character of the building; and their finishes and colors. Identification is also critical to differentiate between metals prior to work. Each metal has unique properties and thus requires different treatments.

Not Recommended

Removing or radically changing architectural metal features which are important in defining the overall historic character of the building so that, as a result, the character is diminished.

Removing a major portion of the historic architectural metal from a facade instead of repairing or replacing only the deteriorated metal, then reconstructing the facade with new material in order to create a uniform, or "improved" appearance.

Radically changing the type of finish or its historic color or accent scheme.

Protect and maintain

Protecting and maintaining architectural metals from corrosion by providing proper drainage so that water does not stand on flat, horizontal surfaces or accumulate in curved, decorative features.

Failing to identify, evaluate, and treat the causes of corrosion, such as moisture from leaking roofs or gutters.

Placing incompatible metals together without providing a reliable separation material. Such incompatibility can result in galvanic corrosion of the less noble metal, e.g., copper will corrode cast iron, steel, tin, and aluminum.

Cleaning architectural metals, when appropriate, to remove corrosion prior to repainting or applying other appropriate protective coatings.

Exposing metals which were intended to be protected from the environment.

Applying paint or other coatings to metals such as copper, bronze, or stainless steel that were meant to be exposed.

Identifying the particular type of metal prior to any cleaning procedure and then testing to assure that the gentlest cleaning method possible is selected or determining that cleaning is inappropriate for the particular metal.

Using cleaning methods which alter or damage the historic color, texture, and finish of the metal; or cleaning when it is inappropriate for the metal.

Removing the patina of historic metal. The patina may be a protective coating on some metals, such as bronze or copper, as well as a significant historic finish.

Recommended

Cleaning soft metals such as lead, tin, copper, terneplate, and zinc with appropriate chemical methods because their finishes can be easily abraded by blasting methods.

Using the gentlest cleaning methods for cast iron, wrought iron, and steel—hard metals—in order to remove paint buildup and corrosion. If handscraping and wire brushing have proven ineffective, low pressure grit blasting may be used as long as it does not abrade or damage the surface.

Not Recommended

Cleaning soft metals such as lead, tin, copper, terneplate, and zinc with grit blasting which will abrade the surface of the metal.

Failing to employ gentler methods prior to abrasively cleaning cast iron, wrought iron or steel; or using high pressure grit blasting.

Although these pressed metal storefronts have been well maintained over the years, gaps in the seams between the metal sheets above the door and slight stains along the cornice line indicate a possible roof leak. The roof should be investigated and repaired before the moisture results in rust and more severe metal deterioration.

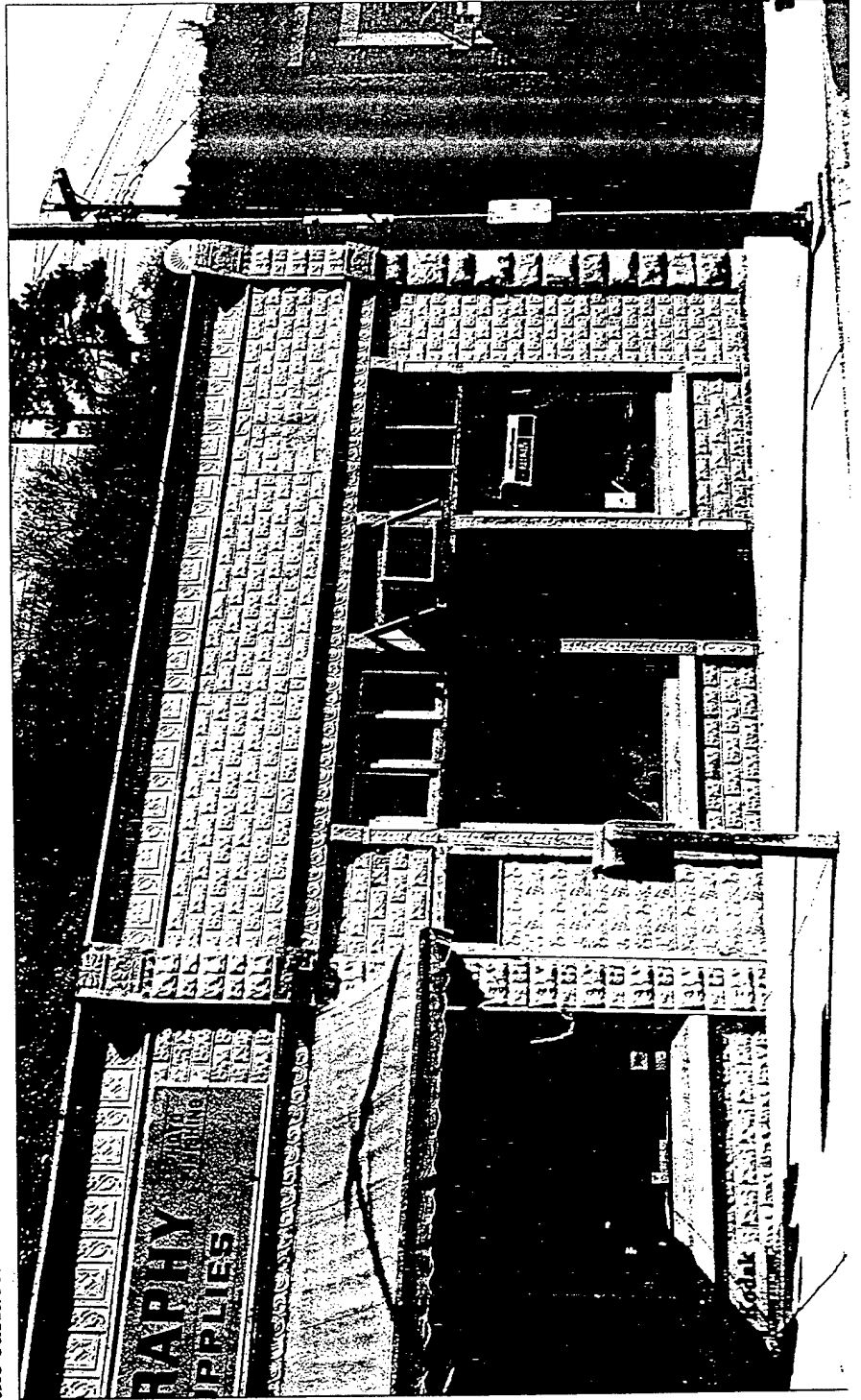

Recommended

Applying appropriate paint or other coating systems after cleaning in order to decrease the corrosion rate of metals or alloys.

Repainting with colors that are appropriate to the historic building or district.

Not Recommended

Failing to re-apply protective coating systems to metals or alloys that require them after cleaning so that accelerated corrosion occurs.

Using new colors that are inappropriate to the historic building or district.

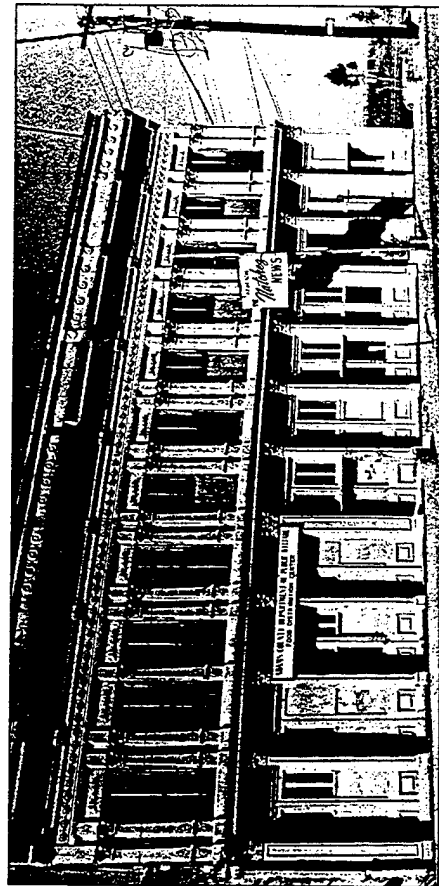

Deteriorated portions of the decorative pressed metal cornice have been inappropriately replaced with non-matching, plain metal sheets, adversely affecting the historic character of this building.

Photo: Jack E. Boucher, HABS.

Applying an appropriate protective coating such as lacquer to an architectural metal feature such as a bronze door which is subject to heavy pedestrian use.

Evaluating the overall condition of the architectural metals to determine whether more than protection and maintenance are required, that is, if repairs to features will be necessary.

Failing to assess pedestrian use or new access patterns so that architectural metal features are subject to damage by use or inappropriate maintenance such as salting adjacent sidewalks.

Failing to undertake adequate measures to assure the protection of architectural metal features.

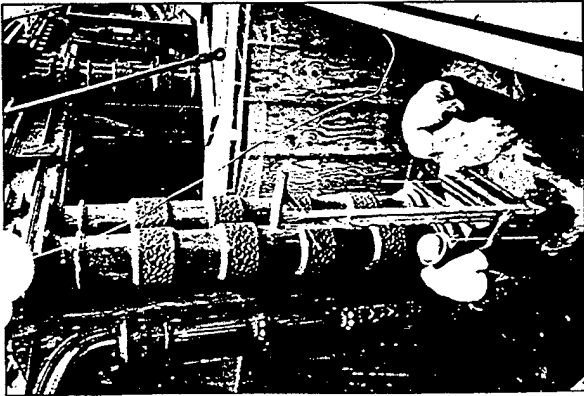

The cast-iron columns of this theater are being repaired during rehabilitation. Some of the cast iron elements such as the smaller, non-structural columns missing from the bay on the right will be replaced with a lightweight substitute material such as cast aluminum, an acceptable alternative according to the Standards.

Recommended

Repair

Repairing architectural metal features by patching, splicing, or otherwise reinforcing the metal following recognized preservation methods. Repairs may also include the limited replacement in kind—or with a compatible substitute material—of those extensively deteriorated or missing parts of features when there are surviving prototypes such as porch balusters, column capitals or bases; or porch cresting.

Replace

Replacing in kind an entire architectural metal feature that is too deteriorated to repair—if the overall form and detailing are still evident—using the physical evidence as a model to reproduce the feature. Examples could include cast iron porch steps or steel sash windows. If using the same kind of material is not technically or economically feasible, then a compatible substitute material may be considered.

Recommended

Design for Missing Historic Features

Designing and installing a new architectural metal feature such as a metal cornice or cast iron capital when the historic feature is completely missing. It may be an accurate restoration using historical, pictorial, and physical documentation; or be a new design that is compatible with the size, scale, material, and color of the historic building.

Not Recommended

Replacing an entire architectural metal feature such as a column or a balustrade when repair of the metal and limited replacement of deteriorated or missing parts are appropriate.

Using a substitute material for the replacement part that does not convey the visual appearance of the surviving parts of the architectural metal feature or is that physically or chemically incompatible.

Removing an architectural metal feature that is unrepairable and not replacing it; or replacing it with a new architectural metal feature that does not convey the same visual appearance.

Not Recommended

Creating a false historical appearance because the replaced architectural metal feature is based on insufficient historical, pictorial, and physical documentation.

Introducing a new architectural metal feature that is incompatible in size, scale, material and color.

Building
Exterior
Roofs

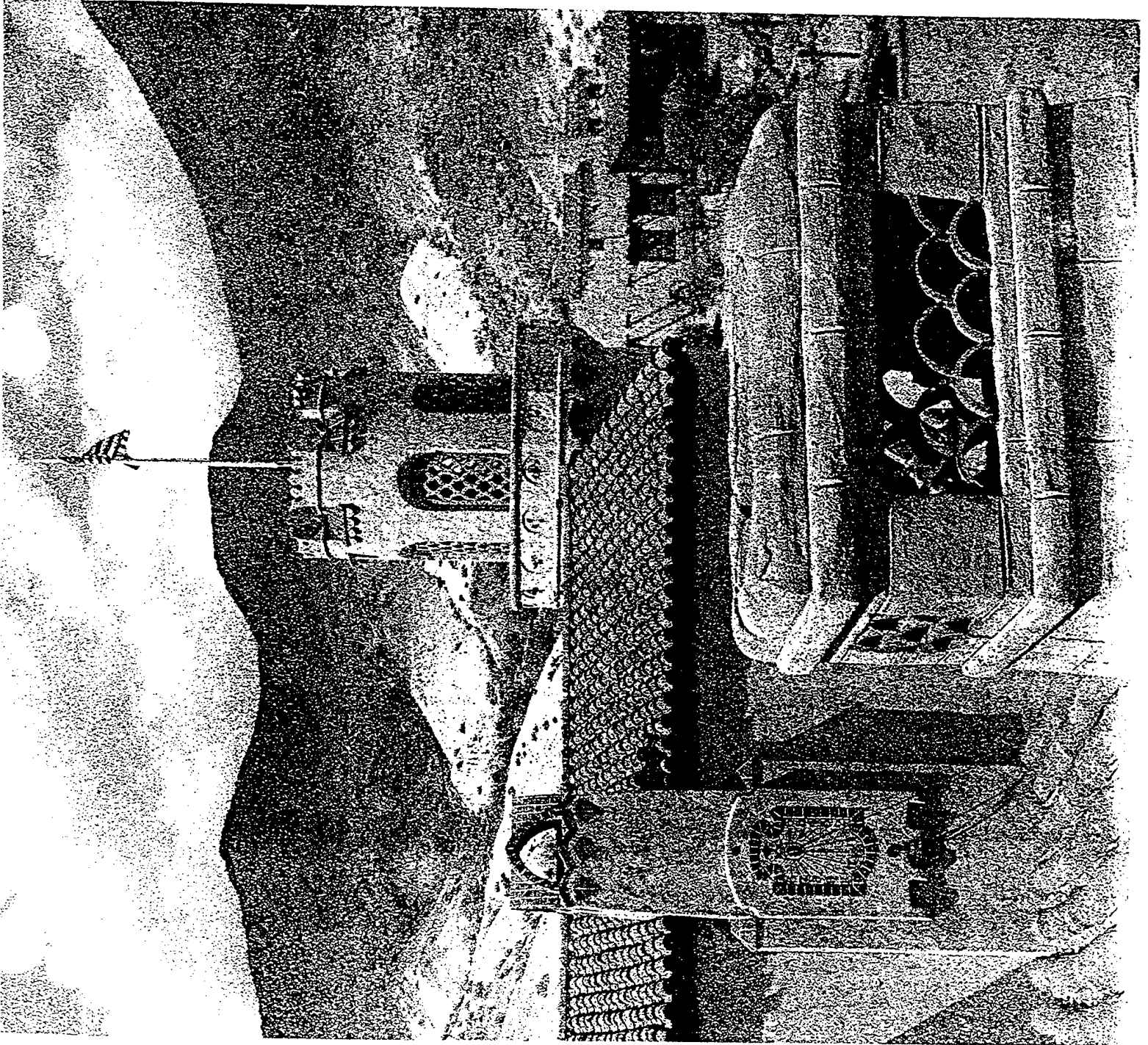

Building Exterior Roofs

The roof—with its shape; features such as cresting, dormers, cupolas, and chimneys; and the size, color, and patterning of the roofing material—is an important design element of many historic buildings. In addition, a weather tight roof is essential to the longterm preservation of the entire structure. Historic roofing reflects availability of materials, levels of construction technology, weather, and cost. For example, throughout the country in all periods of history, wood shingles have been used—their size, shape, and detailing differing according to regional craft practices. European settlers used clay tile for roofing as early as the mid-17th century. In some cities, such as New York and Boston, clay was popularly used as a precaution against fire. The Spanish influence in the use of clay tiles is found in the southern, southwestern and western states. In the mid-19th century, tile roofs were often replaced by sheet-metal, which is lighter and easier to maintain. Evidence of the use

of slate for roofing dates from the mid-17th century. Slate has remained popular for its durability, fireproof qualities, and decorative applications. The use of metals for roofing and roof features dates from the 18th century, and includes the use of sheet iron, corrugated iron, galvanized metal, tinplate, copper, lead and zinc. Awareness of these and other traditions of roofing materials and their detailing will contribute to more sensitive treatment.



Recommended

Identify, retain, and preserve

Identifying, retaining, and preserving roofs—and their functional and decorative features—that are important in defining the overall historic character of the building. This includes the roof's shape, such as hipped, gambrel, and mansard; decorative features such as cupolas, cresting, chimneys, and weathervanes; and roofing material such as slate, wood, clay tile, and metal, as well as its size, color, and patterning.

This well-maintained mansard roof displays its handsome and varied decorative detailing—cast-iron cresting, wood shingles, and pedimented dormers.



Protect

Protecting and maintaining a roof by cleaning the gutters and downspouts and replacing deteriorated flashing. Roof sheathing should also be checked for proper venting to prevent moisture condensation and water penetration; and to insure that materials are free from insect infestation.

Not Recommended

Radically changing, damaging, or destroying roofs which are important in defining the overall historic character of the building so that, as a result, the character is diminished.

Removing a major portion of the roof or roofing material that is repairable, then reconstructing it with new material in order to create a uniform, or "improved" appearance.

Changing the configuration of a roof by adding new features such as dormer windows, vents, or skylights so that the historic character is diminished.

Stripping the roof of sound historic material such as slate, clay tile, wood, and architectural metal.

Applying paint or other coatings to roofing material which has been historically uncoated.

Failing to clean and maintain gutters and downspouts properly so that water and debris collect and cause damage to roof fasteners, sheathing, and the underlying structure.

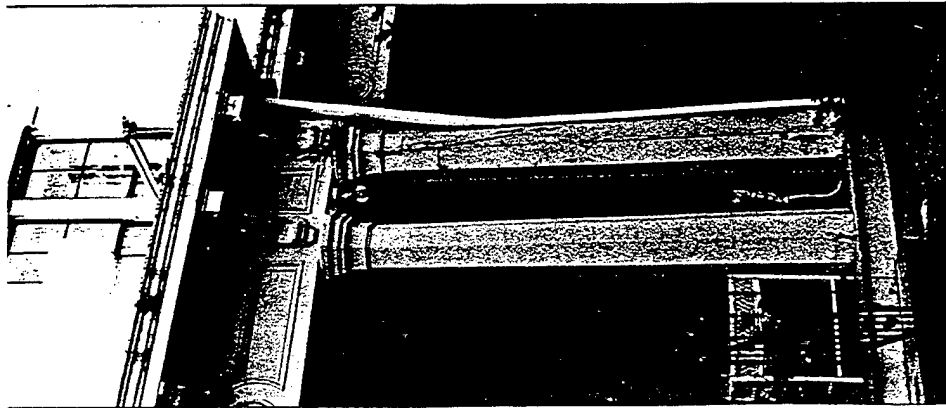

The roof drainage system has been neglected for such a long time that, as a result, the wood cornice and a porch column are both severely deteriorated.

Recommended

Providing adequate anchorage for roofing material to guard against wind damage and moisture penetration.

Protecting a leaking roof with plywood and building paper until it can be properly repaired.

Repair

Repairing a roof by reinforcing the historic materials which comprise roof features. Repairs will also generally include the limited replacement in kind—or with compatible substitute material—of those extensively deteriorated or missing parts of features when there are surviving prototypes such as cupola louvers, dentils, dormer roofing; or slates, tiles, or wood shingles on a main roof.

Not Recommended

Allowing roof fasteners, such as nails and clips to corrode so that roofing material is subject to accelerated deterioration.

Permitting a leaking roof to remain unprotected so that accelerated deterioration of historic building materials—masonry, wood, plaster, paint and structural members—occurs.

Replacing an entire roof feature such as a cupola or dormer when repair of the historic materials and limited replacement of deteriorated or missing parts are appropriate.

Failing to reuse intact slate or tile when only the roofing substrate needs replacement.

Using a substitute material for the replacement part that does not convey the visual appearance of the surviving parts of the roof or that is physically or chemically incompatible.

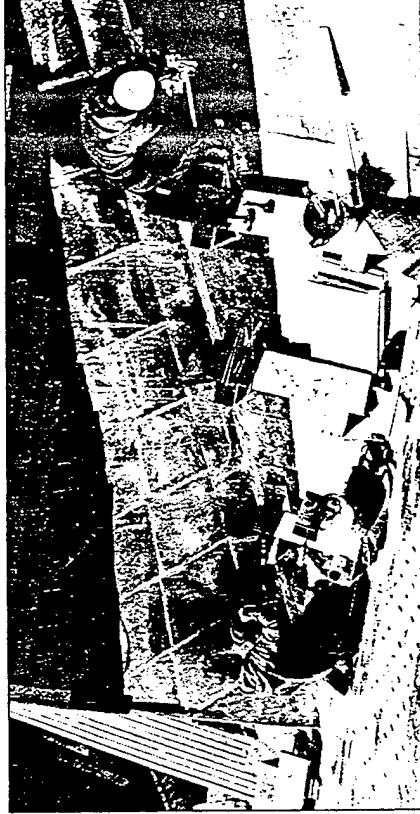

New copper valley flashing is installed as part of overall repairs to the historic slate roof and its drainage system.

Recommended

Replace

Replacing in kind an entire feature of the roof that is too deteriorated to repair—if the overall form and detailing are still evident—using the physical evidence as a model to reproduce the feature. Examples can include a large section of roofing, or a dormer or chimney. If using the same kind of material is not technically or economically feasible, then a compatible substitute material may be considered.



The size, shape, and detailing of the historic shingles as well as the method of fabrication and installation were carefully researched prior to selecting this new wood-shingle roofing.

Not Recommended

Removing a feature of the roof that is unrepairable, such as a chimney or dormer, and not replacing it with a new feature that does not convey the same visual appearance.

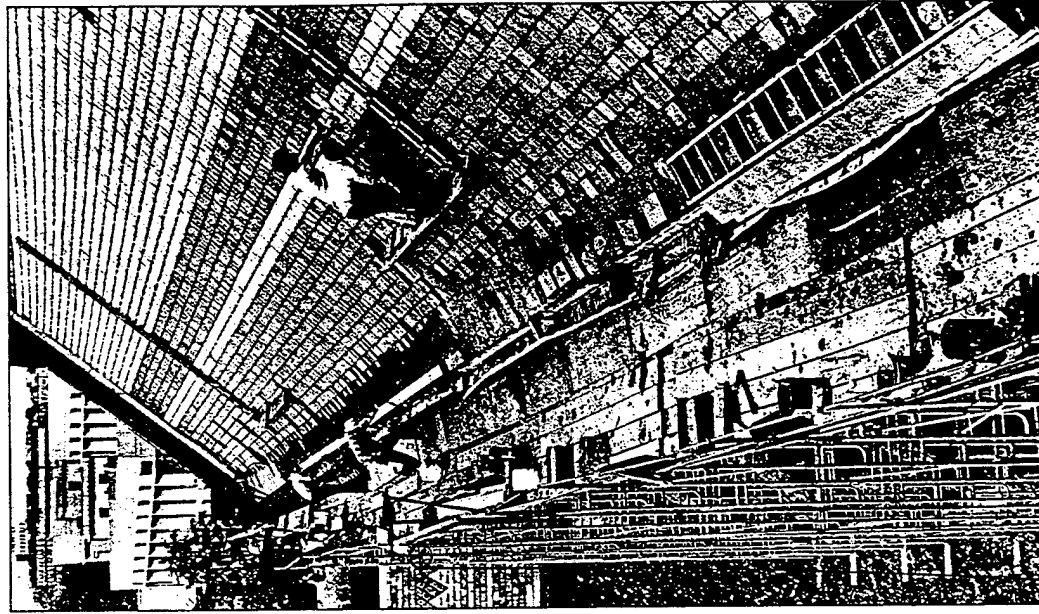

Workmen are in the process of removing deteriorated roofing slates and replacing them with new matching slates.

New galvanized sheet-iron shingles will need to be reproduced using the pattern of the original shingle.

The following work is highlighted to indicate that it represents the particularly complex technical or design aspects of rehabilitation projects and should only be considered after the preservation concerns listed above have been addressed.

Recommended

Design for Missing Historic Features

Designing and constructing a new feature when the historic feature is completely missing, such as chimney or cupola. It may be an accurate restoration using historical, pictorial, and physical documentation; or be a new design that is compatible with the size, scale, material, and color of the historic building.

Alterations/Additions for the New Use

Installing mechanical and service equipment on the roof such as air conditioning, transformers, or solar collectors when required for the new use so that they are inconspicuous from the public right-of-way and do not damage or obscure character-defining features.

Designing additions to roofs such as residential, office, or storage spaces; elevator housing; decks and terraces; or dormers or skylights when required by the new use so that they are inconspicuous from the public right-of-way and do not damage or obscure character-defining features.

Not Recommended

Creating a false historical appearance because the replaced feature is based on insufficient historical, pictorial, and physical documentation.

Introducing a new roof feature that is incompatible in size, scale, material and color.

Installing mechanical or service equipment so that it damages or obscures character-defining features; or is conspicuous from the public right-of-way.

Radically changing a character-defining roof shape or damaging or destroying character-defining roofing material as a result of incompatible design or improper installation techniques.

Building
Exterior

Windows

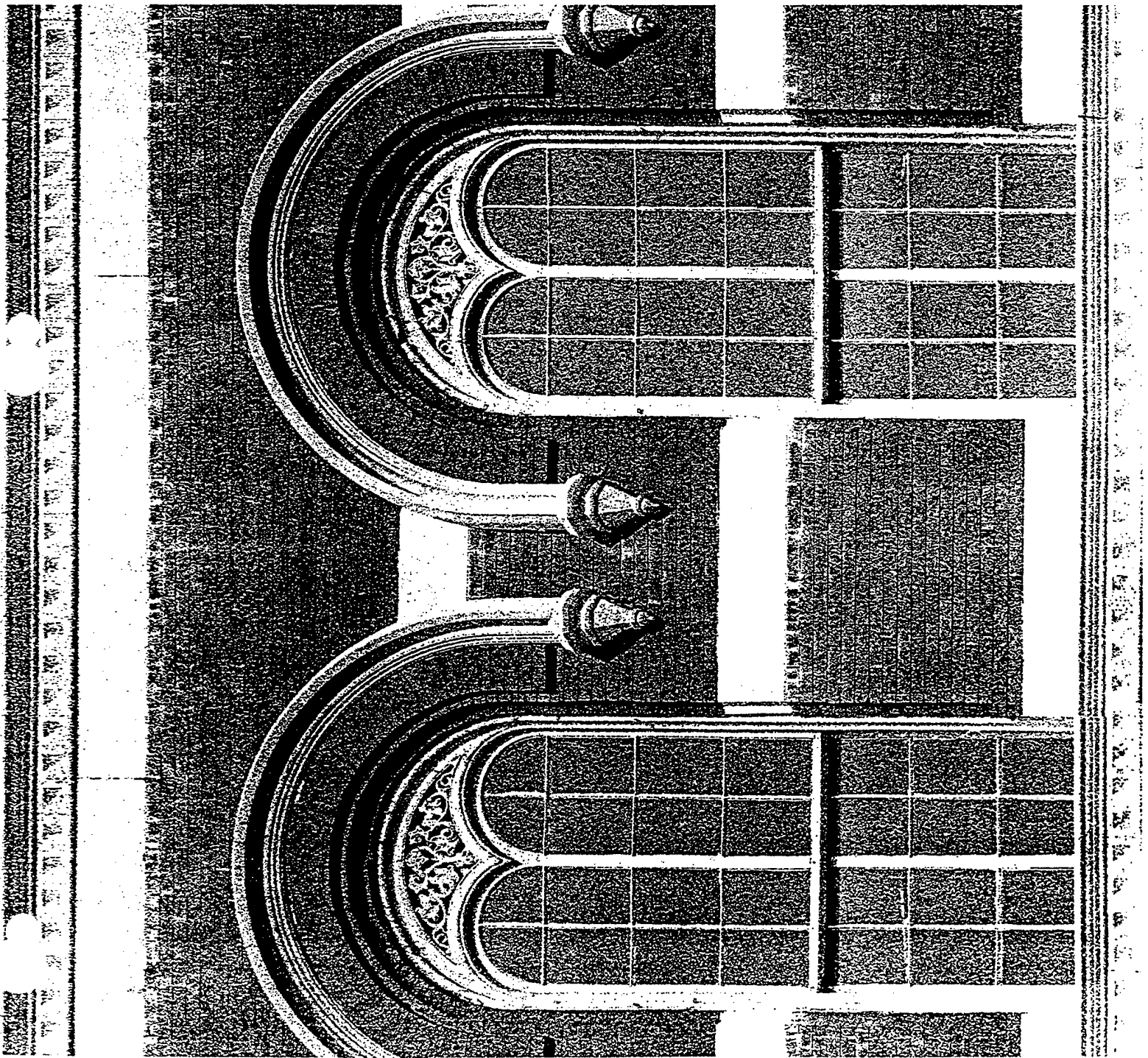

Building Exterior Windows

Technology and prevailing architectural styles have shaped the history of windows in the United States starting in the 17th century with wooden casement windows with tiny glass panes seated in lead cames. From the transitional single-hung sash in the early 1700s to the true double-hung sash later in the same century, these early wooden windows were characterized by the small panes, wide muntins, and the way in which decorative trim was used on both the exterior and interior of the window. As the sash thickness increased by the turn of the century, muntins took on a thinner appearance as they narrowed in width but increased in thickness according to the size of the window and design practices. Regional traditions continued to have an impact on the prevailing window design such as with the long-term use of "french windows" in areas of the deep South.

Changes in technology led to the possibility of larger glass panes so that by the mid-19th century, two-over-two lights were common; the manufacturing of plate glass in the United States allowed

for dramatic use of large sheets of glass in commercial and office buildings by the late 19th century. With mass-produced windows, mail order distribution, and changing architectural styles, it was possible to obtain a wide range of window designs and light patterns in sash. Popular versions of Arts and Crafts houses constructed in the early 20th century frequently utilized smaller lights in the upper sash set in groups or pairs and saw the re-emergence of casement windows. In the early 20th century, the desire for fireproof building construction in dense urban areas contributed to the growth of a thriving steel window industry along with a market for hollow metal and metal clad wooden windows.

As one of the few parts of a building serving as both an interior and exterior feature, windows are nearly always an important part of the historic character of a building. In most buildings, windows also comprise a considerable amount of the historic fabric of the wall plane and thus are deserving of special consideration in a rehabilitation project.

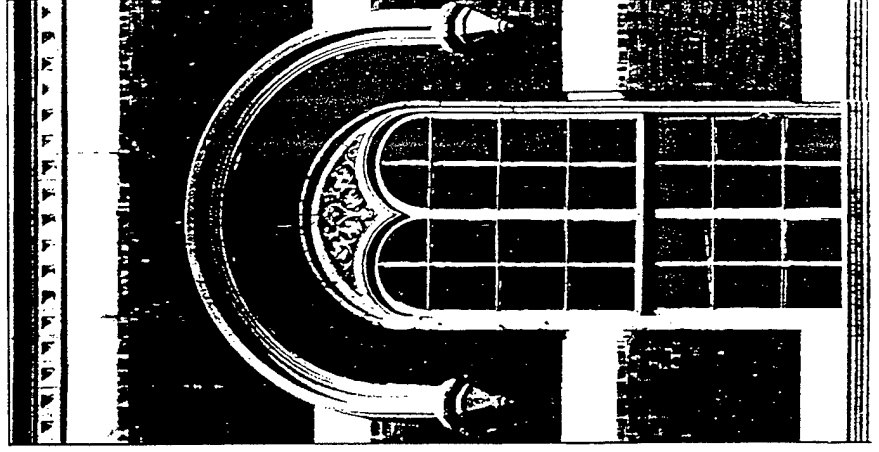

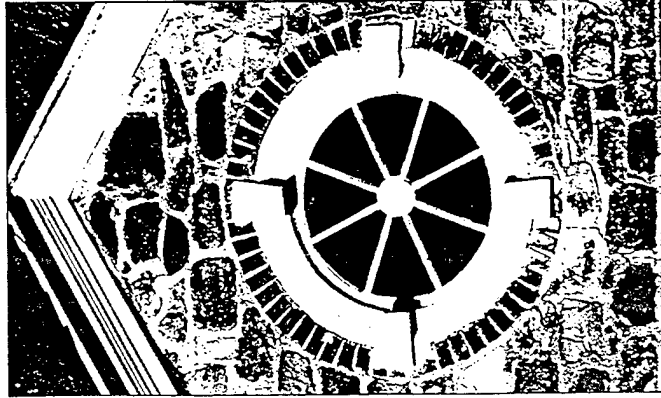
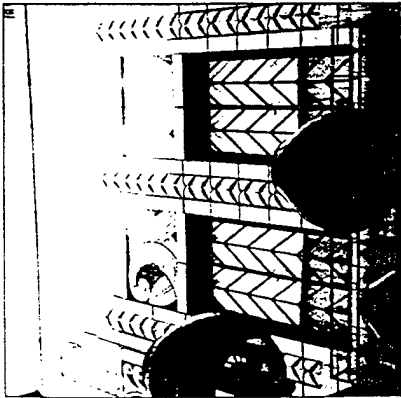

The distinctive shape and decorative detailing of a building's windows often help establish its architectural style and character.

Recommended

Identify, retain, and preserve

Identifying, retaining, and preserving windows — and their functional and decorative features — that are important in defining the overall historic character of the building. Such features can include frames, sash, muntins, glazing, sills, heads, hoodmolds, panelled or decorated jambs and moldings, and interior and exterior shutters and blinds.

Conducting an in-depth survey of the conditions of existing windows early in rehabilitation planning so that repair and upgrading methods and possible replacement options can be fully explored.

Protect and maintain

Protecting and maintaining the wood and architectural metal which comprise the window frame, sash, muntins, and surrounds through appropriate surface treatments such as cleaning, rust removal, limited paint removal, and re-application of protective coating systems.

Not Recommended

Removing or radically changing windows which are important in defining the historic character of the building so that, as a result, the character is diminished.

Changing the number, location, size or glazing pattern of windows, through cutting new openings, blocking-in windows, and installing replacement sash that do not fit the historic window opening.

Changing the historic appearance of windows through the use of inappropriate designs, materials, finishes, or colors which noticeably change the sash, depth of reveal, and muntin configuration; the reflectivity and color of the glazing; or the appearance of the frame.

Obscuring historic window trim with metal or other material.

Stripping windows of historic material such as wood, cast iron, and bronze.

Replacing windows solely because of peeling paint, broken glass, stuck sash, and high air infiltration. These conditions, in themselves, are no indication that windows are beyond repair.

Failing to provide adequate protection of materials on a cyclical basis so that deterioration of the windows results.



Maintaining a historic window may include work as basic as replacing a sash cord.

Recommended

Making windows weather tight by re-caulking and replacing or installing weatherstripping. These actions also improve thermal efficiency.

Evaluating the overall condition of materials to determine whether more than protection and maintenance are required, i.e. if repairs to windows and window features will be required.

Repair

Repairing window frames and sash by patching, splicing, consolidating or otherwise reinforcing. Such repair may also include replacement in kind of those parts that are either extensively deteriorated or are missing when there are surviving prototypes such as architraves, hoodmolds, sash, sills, and interior or exterior shutters and blinds.

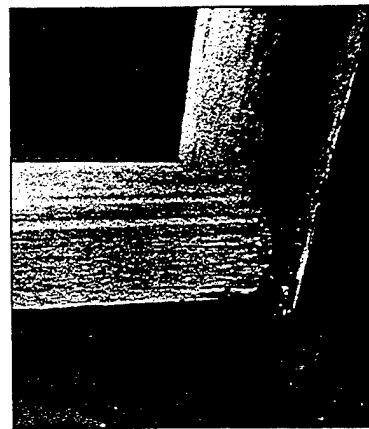

Deterioration of poorly maintained windows usually begins on horizontal surfaces where water collects. Problem areas on this sill are clearly indicated by paint failure due to moisture.

32 Building Exterior Windows

Not Recommended

Retrofitting or replacing windows rather than maintaining the sash, frame, and glazing.

Failing to undertake adequate measures to assure the protection of historic windows.

Replacing an entire window when repair of materials and limited replacement of deteriorated or missing parts are appropriate.

Failing to reuse serviceable window hardware such as brass sash lifts and sash locks.

Using substitute material for the replacement part that does not convey the visual appearance of the surviving parts of the window or that is physically or chemically incompatible.

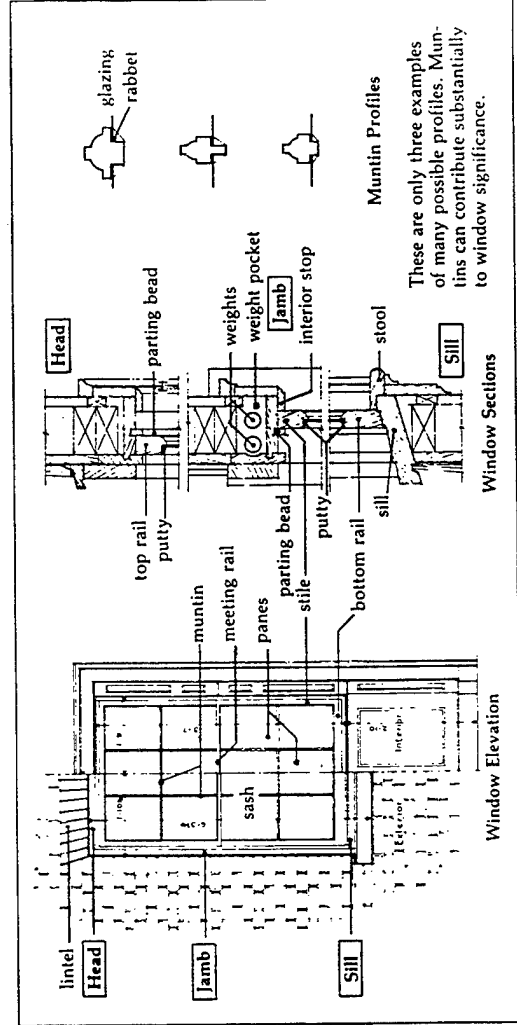

These drawings identify individual parts and fabrication details of a historic wooden double-hung window.

Recommended

Replace

Replacing in kind an entire window that is too deteriorated to repair using the same sash and pane configuration and other design details. If using the same kind of material is not technically or economically feasible when replacing windows deteriorated beyond repair, then a compatible substitute material may be considered. For example, on certain types of large buildings, particularly high-rises, aluminum windows may be a suitable replacement for historic wooden sash provided wooden replacement are not practical and the design detail of the historic windows can be matched. Historic color duplication, custom contour panning, incorporation of either an integral muntin or 5/8" deep trapezoidal exterior muntin grids, where applicable, retention of the same glass to frame ratio, matching of the historic reveal, and duplication of the frame width, depth, and such existing decorative details as arched tops should all be components in aluminum replacements for use on historic buildings.

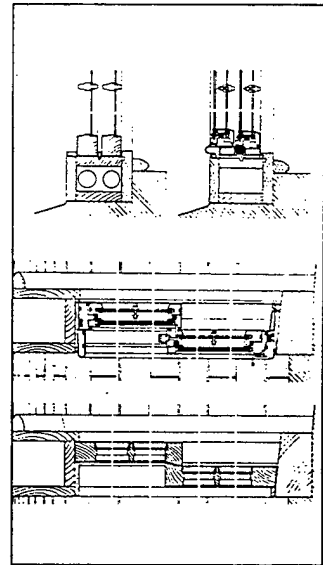

For some larger buildings, it may be appropriate to replace seriously deteriorated windows with new ones that replicate most of the historic visual qualities. This two-part drawing shows the original windows in a mill and the rehabilitation solution that retained the wood frames, then utilized an aluminum sash with true divided lights and a piggyback interior storm panel.

Not Recommended

Removing a character-defining window that is unrepairable and blocking it in; or replacing it with a new window that does not convey the same visual appearance.

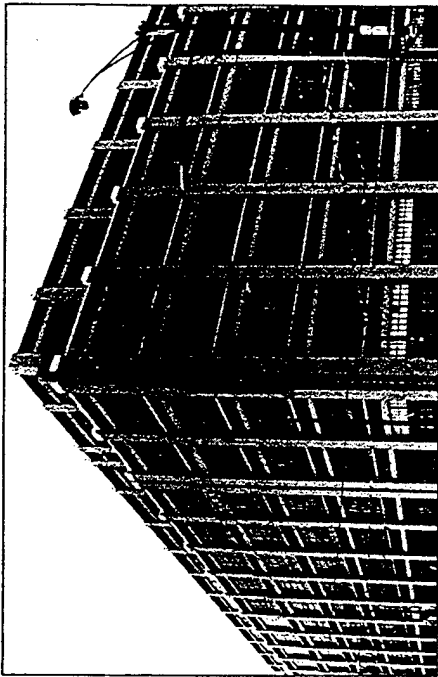

The steel pivot windows in this historic manufacturing building were replaced with new windows which matched the multi-lighted originals.

The following work is highlighted to indicate that it represents the particularly complex technical or design aspects of rehabilitation projects and should only be considered after the preservation concerns listed above have been addressed.

Recommended

Design for Missing Historic Features

Designing and installing new windows when the historic windows (frames, sash and glazing) are completely missing. The replacement windows may be an accurate restoration using historical, pictorial, and physical documentation; or be a new design that is compatible with the window openings and the historic character of the building.

Alterations/Additions for the New Use

Designing and installing additional windows on rear or other non-character-defining elevations if required by the new use. New window openings may also be cut into exposed party walls. Such design should be compatible with the overall design of the building, but not duplicate the fenestration pattern and detailing of a character-defining elevation.

Providing a setback in the design of dropped ceilings when they are required for the new use to allow for the full height of the window openings.

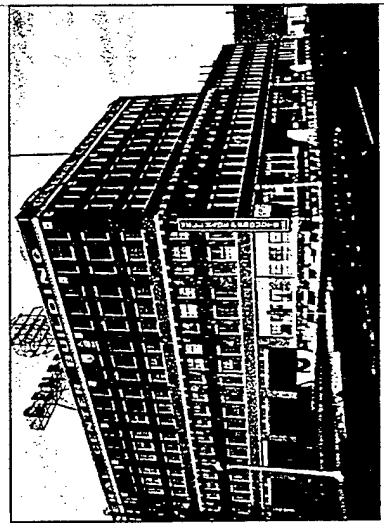

Not Recommended

Creating a false historical appearance because the replaced window is based on insufficient historical, pictorial, and physical documentation.

Introducing a new design that is incompatible with the historic character of the building.

Installing new windows, including frames, sash, and muntin configuration that are incompatible with the building's historic appearance or obscure, damage, or destroy character-defining features.

Inserting new floors or furred-down ceilings which cut across the glazed areas of windows so that the exterior form and appearance of the windows are changed.

When the six-over-six windows were replaced with inappropriate single sheets of tinted glass, the historic industrial character of this building was lost.

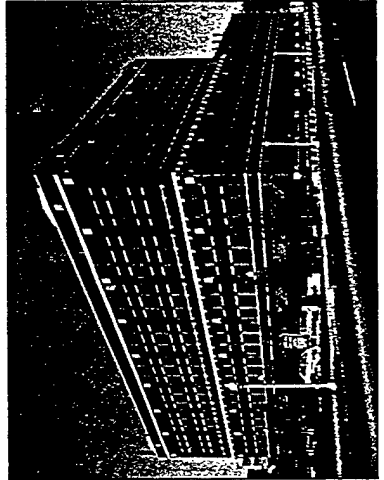

Building
Exterior
*Entrances
and Porches*

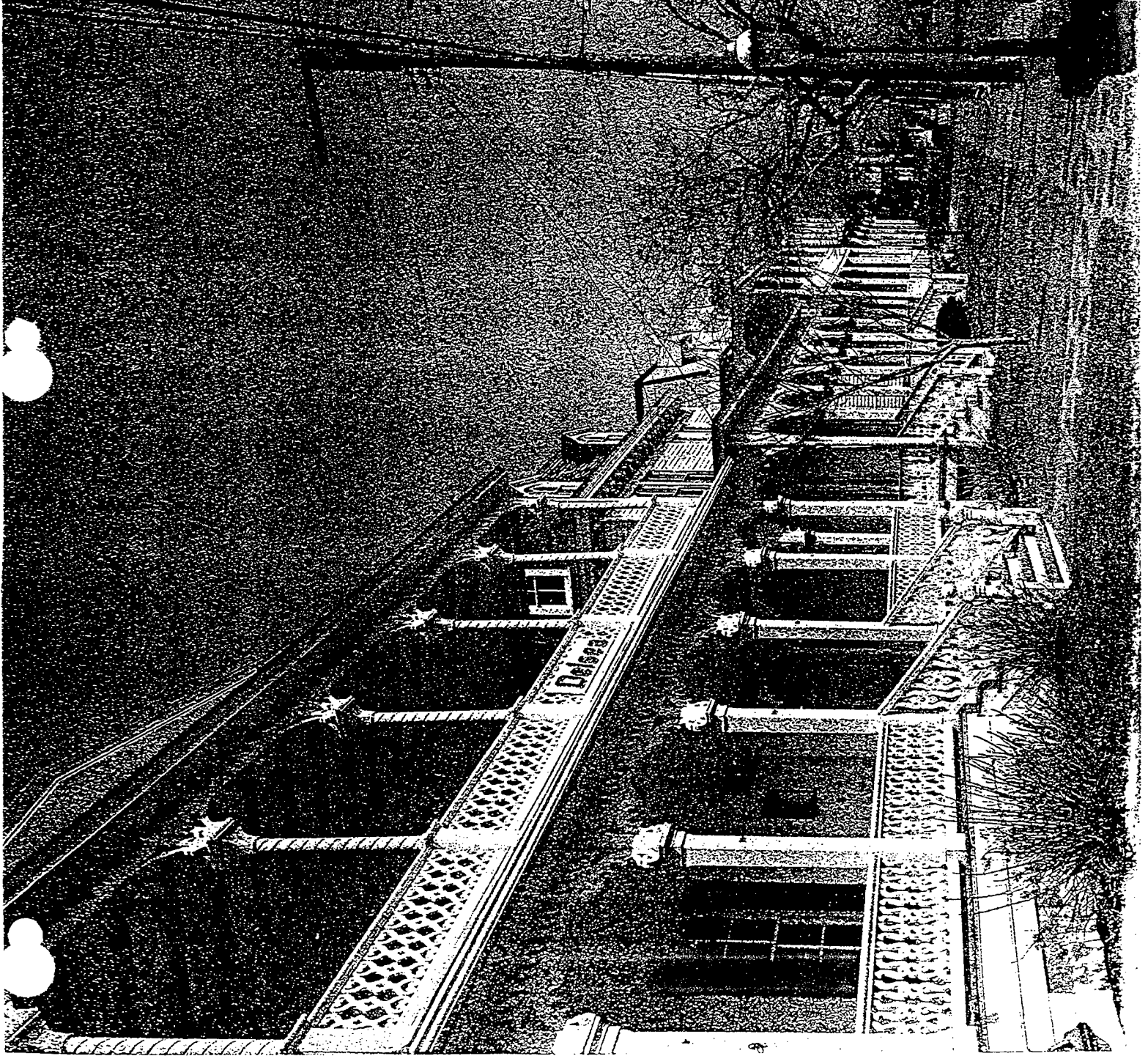

Building Exterior

Entrances and Porches

Entrances and porches are quite often the focus of historic buildings, particularly on primary elevations. Together with their functional and decorative features such as doors, steps, balustrades, pilasters, and entablatures, they can be extremely important in defining the overall character of a building. In many cases, porches were energy-saving devices, shading southern and western elevations. Usually entrances and porches were integral components of a historic building's design; for example, porches on Greek Revival houses, with Doric or Ionic columns and pediments, echoed the architectural elements and features of the larger building. Central one-bay porches or arcaded porches are evident in Italianate style buildings of the 1860s. Doors of Renaissance Revival style buildings frequently supported entablatures or pedi-

ments. Porches were particularly prominent features of Eastlake and Stick Style houses; porch posts, railings, and balusters were characterized by a massive and robust quality, with members turned on a lathe. Porches of bungalows of the early 20th century were characterized by tapered porch posts, exposed post and beams, and low pitched roofs with wide overhangs. Art Deco commercial buildings were entered through stylized glass and stainless steel doors.

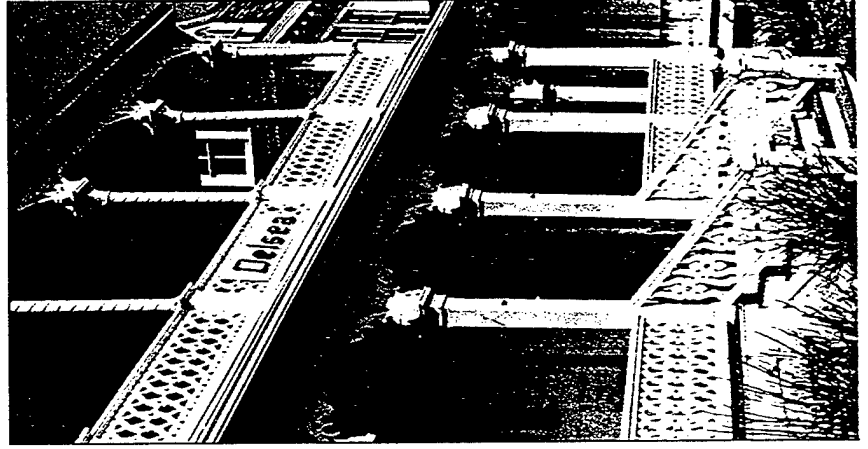

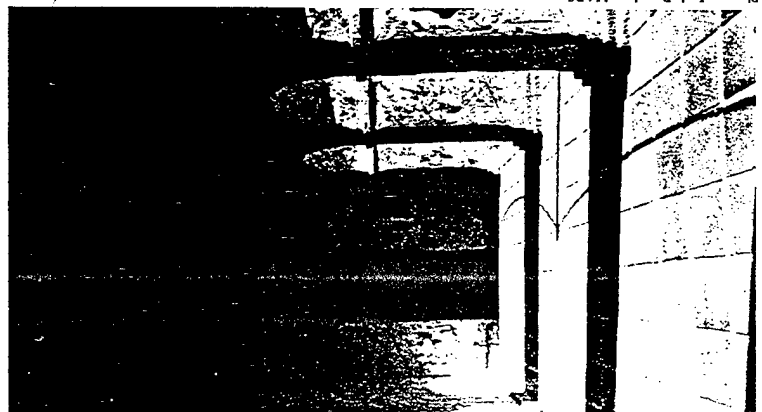
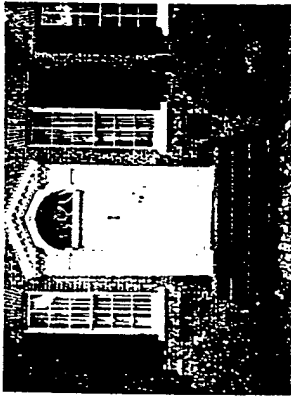

Photos: Jack Boucher, HABS.

Recommended

Identify, retain, and preserve

Identifying, retaining, and preserving entrances — and their functional and decorative features — that are important in defining the overall historic character of the building such as doors, fanlights, sidelights, pilasters, entablatures, columns, balustrades, and stairs.

Not Recommended

Removing or radically changing entrances and porches which are important in defining the overall historic character of the building so that, as a result, the character is diminished.

Stripping entrances and porches of historic material such as wood, cast iron, terra cotta tile, and brick.

Removing an entrance or porch because the building has been re-oriented to accommodate a new use.

Cutting new entrances on a primary elevation.

Altering utilitarian or service entrances so they appear to be formal entrances by adding panelled doors, fanlights, and sidelights.

Protect and maintain

Protecting and maintaining the masonry, wood, and architectural metal that comprise entrances and porches through appropriate surface treatments such as cleaning, rust removal, limited paint removal, and re-application of protective coating systems.

Evaluating the overall condition of materials to determine whether more than protection and maintenance are required, that is, if repairs to entrance and porch features will be necessary.

Failing to provide adequate protection to materials on a cyclical basis so that deterioration of entrances and porches results.

Failing to undertake adequate measures to assure the protection of historic entrances and porches.

A variety of historic entrances and porches is illustrated here, ranging from the elegance of a Georgian-style entrance, to the more vernacular nature of a 19th century wood porch, to the utilitarian, yet romantic Mediterranean-style loggia.

Recommended

Repair

Repairing entrances and porches by reinforcing the historic materials. Repair will also generally include the limited replacement in kind—or with compatible substitute material—of those extensively deteriorated or missing parts of repeated features where there are surviving prototypes, such as balustrades, cornices, entablatures, columns, sidelights, and stairs.

In the 19th century some cast-iron porches could be purchased by mail, such as this made-to-order veranda which was featured in an 1870 foundry catalog.

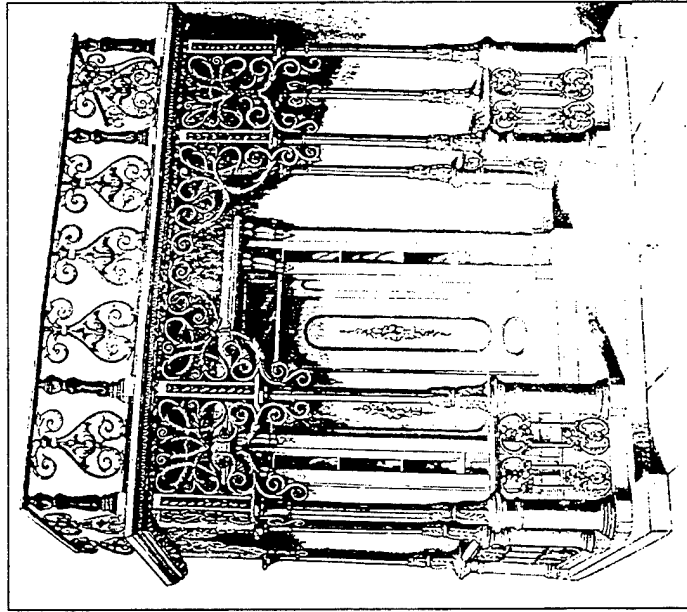

Not Recommended

Replacing an entire entrance or porch when the repair of materials and limited replacement of parts are appropriate.

Using a substitute material for the replacement parts that does not convey the visual appearance of the surviving parts of the entrance and porch or that is physically or chemically incompatible.

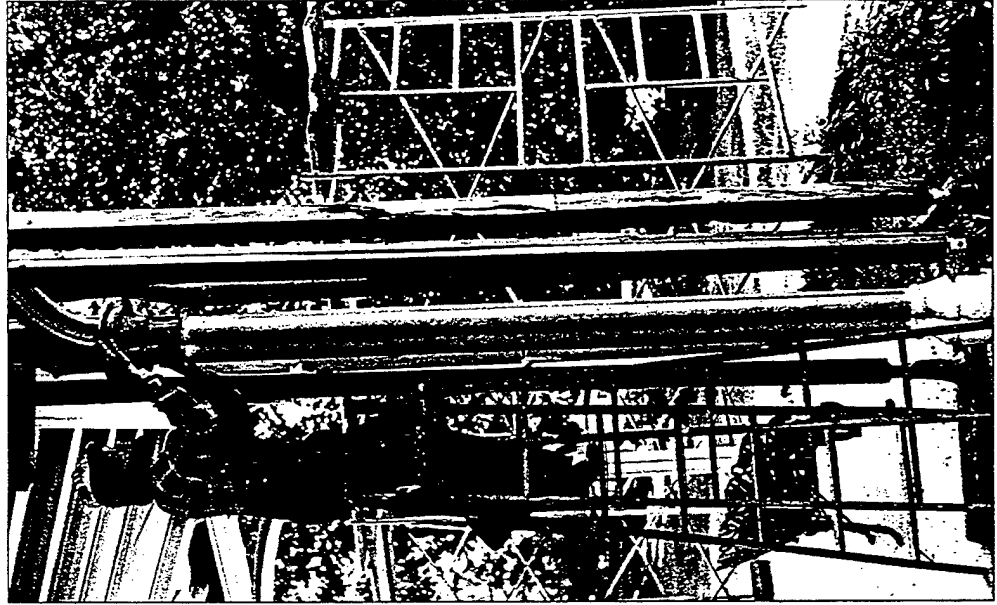

Careful inspection of porch features such as these column capitals is necessary before initiating a rehabilitation project.

Recommended

Replace

Replacing in kind an entire entrance or porch that is too deteriorated to repair—if the form and detailing are still evident—using the physical evidence as a model to reproduce the feature. If using the same kind of material is not technically or economically feasible, then a compatible substitute material may be considered.

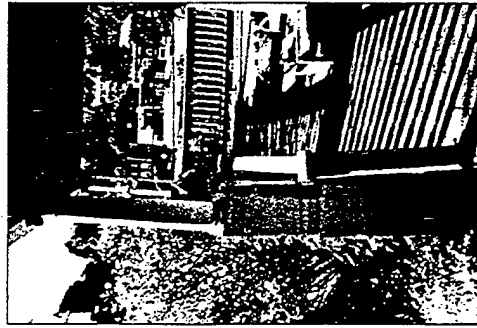
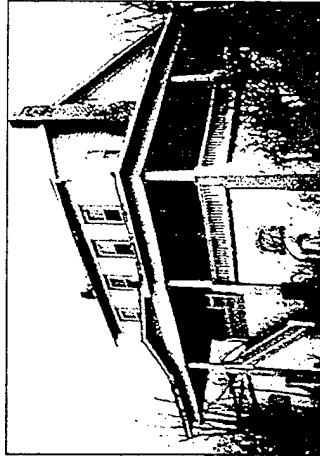

Not Recommended

Removing an entrance or porch that is unrepairable and not replacing it; or replacing it with a new entrance or porch that does not convey the same visual appearance.

A 1910 wrap-around porch was removed from this 1830 house during rehabilitation. Although a later addition, the porch should not have been removed because it had acquired significance over time and was thus an important feature in defining the character of this historic structure.

The following work is highlighted to indicate that it represents the particularly complex technical or design aspects of rehabilitation projects and should only be considered after the preservation concerns listed above have been addressed.

Recommended

Design for Missing Historic Features

Designing and constructing a new entrance or porch when the historic entrance or porch is completely missing. It may be a restoration based on historical, pictorial, and physical documentation; or be a new design that is compatible with the historic character of the building.

Alterations/Additions for the New Use

Designing enclosures for historic porches when required by the new use in a manner that preserves the historic character of the building. This can include using large sheets of glass and recessing the enclosure wall behind existing scrollwork, posts, and balustrades.

Designing and installing additional entrances or porches when required for the new use in a manner that preserves the historic character of the buildings, i.e., limiting such alteration to non-character-defining elevations.

This rehabilitation connected two separate porches, resulting in the creation of a large continuous porch that obscures the historic twin porch design; it is thus incompatible with the historic character of the house.



Not Recommended

Creating a false historical appearance because the replaced entrance or porch is based on insufficient historical, pictorial, and physical documentation.

Introducing a new entrance or porch that is incompatible in size, scale, material, and color.

Enclosing porches in a manner that results in a diminution or loss of historic character such as using solid materials such as wood, stucco, or masonry.

Installing secondary service entrances and porches that are incompatible in size and scale with the historic building or obscure, damage, or destroy character-defining features.

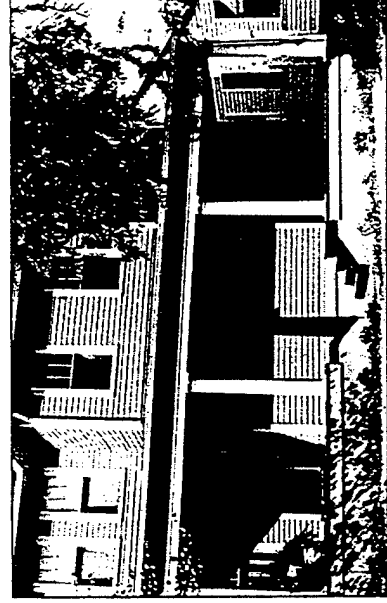

Building
Exterior

Storefronts

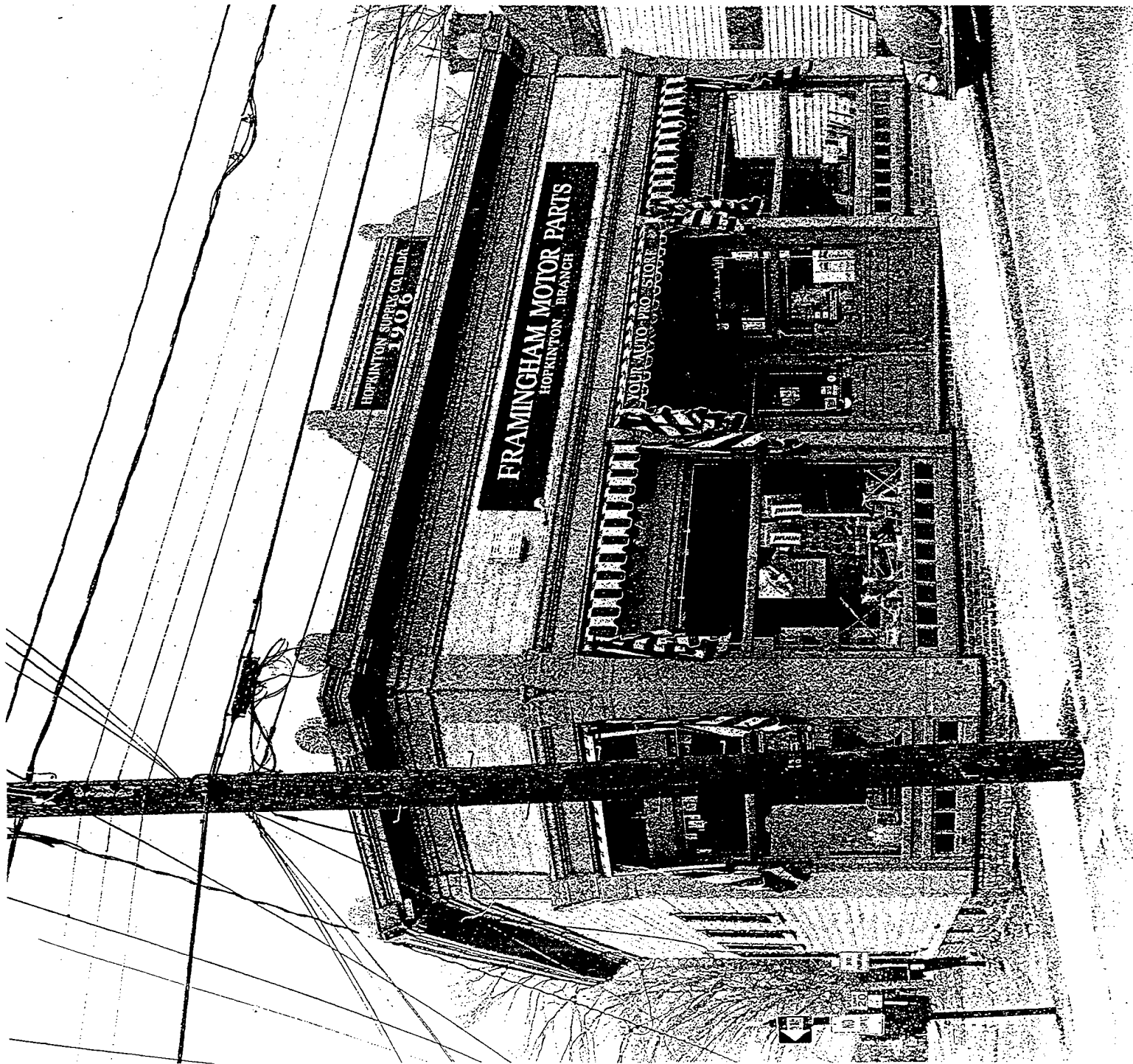

Building Exterior

Storefronts

The storefront is usually the most prominent feature of a historic commercial building, playing a crucial role in a store's advertising and merchandising strategy. Although a storefront normally does not extend beyond the first story, the rest of the building is often related to it visually through a unity of form and detail. Planning should always consider the entire building; window patterns on the upper floors, cornice elements, and other decorative features should be carefully retained, in addition to the storefront itself.

The earliest extant storefronts in the U.S., dating from the late 18th and early 19th centuries, had bay or oriel windows and provided limited display space. The 19th century witnessed the progressive enlargement of display windows

as plate glass became available in increasingly larger units. The use of cast iron columns and lintels at ground floor level permitted structural members to be reduced in size. Recessed entrances provided shelter for sidewalk patrons and further enlarged display areas. In the 1920s and 1930s, aluminum, colored structural glass, stainless steel, glass block, neon, and other new materials were introduced to create Art Deco storefronts.

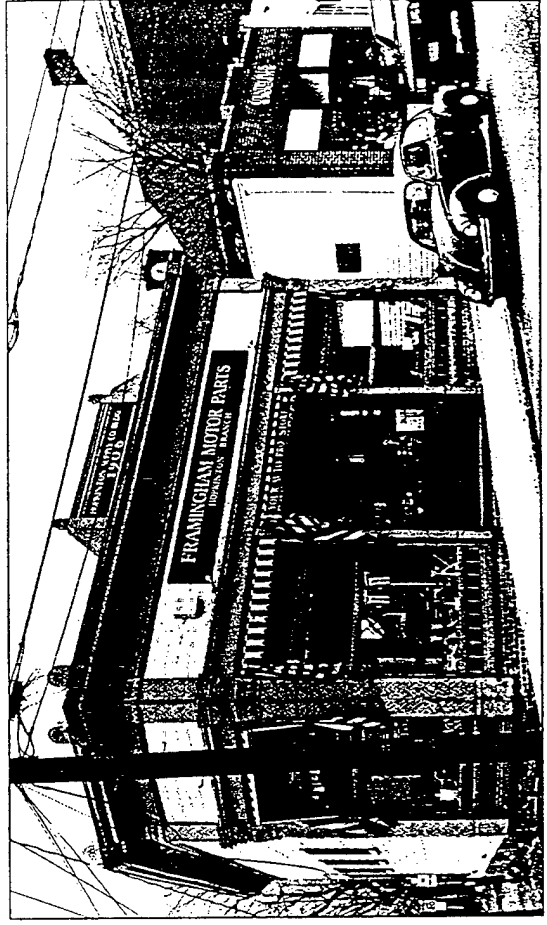

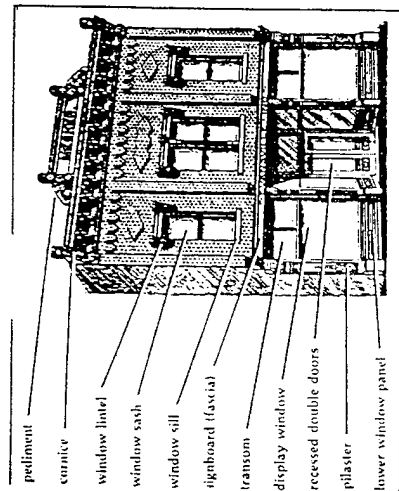

These architectural details are typical of historic commercial buildings (this particular one is No. 4016 in the George L. Mesker and Company catalog of 1905). The design utilized both cast and galvanized iron.

Recommended

Identify, retain, and preserve

Identifying, retaining, and preserving storefronts—and their functional and decorative features—that are important in defining the overall historic character of the building such as display windows, signs, doors, transoms, kick plates, corner posts, and entablatures. The removal of inappropriate, nonhistoric cladding, false mansard roofs, and other later alterations can help reveal the historic character of a storefront.

Not Recommended

Removing or radically changing storefronts—and their features—which are important in defining the overall historic character of the building so that, as a result, the character is diminished.

Changing the storefront so that it appears residential rather than commercial in character.

Removing historic material from the storefront to create a recessed arcade.

Introducing coach lanterns, mansard designs, wood shakes, nonoperable shutters, and small-paned windows if they cannot be documented historically.

Changing the location of a storefront's main entrance.

Protect

Protecting and maintaining masonry, wood, and architectural metals which comprise storefronts through appropriate treatments such as cleaning, rust removal, limited paint removal, and reapplication of protective coating systems.

Protecting storefronts against arson and vandalism before work begins by boarding up windows and installing alarm systems that are keyed into local protection agencies.

Failing to provide adequate protection of materials on a cyclical basis so that deterioration of storefront features results.

Permitting entry into the building through unsecured or broken windows and doors so that interior features and finishes are damaged through exposure to weather or through vandalism.

Stripping storefronts of historic material such as wood, cast iron, terra cotta, carrara glass, and brick.

Recommended

Evaluating the overall condition of storefront materials to determine whether more than protection and maintenance are required, that is, if repairs to features will be necessary.

Not Recommended

Failing to undertake adequate measures to assure the preservation of the historic storefront.



Photo: Jack E. Boucher, HABS.

A false-fronted wood store is now used as a museum. Although the weathered wood is part of its charm, repainting is recommended as a good maintenance practice to protect the wood.

Repair

Repairing storefronts by reinforcing the historic materials. Repairs will also generally include the limited replacement in kind—or with compatible substitute materials—of those extensively deteriorated or missing parts of storefronts where there are surviving prototypes such as transoms, kick plates, pilasters, or signs.

Replacing an entire storefront when repair of materials and limited replacement of its parts are appropriate.

Using substitute material for the replacement parts that does not convey the same visual appearance as the surviving parts of the storefront or that is physically or chemically incompatible.

This sleek red and black Moderne storefront was added to a more staid late-19th century commercial building in the 1930s—both are now in need of repair. According to the Standards, later storefronts that have acquired significance over time should generally be retained in rehabilitation.

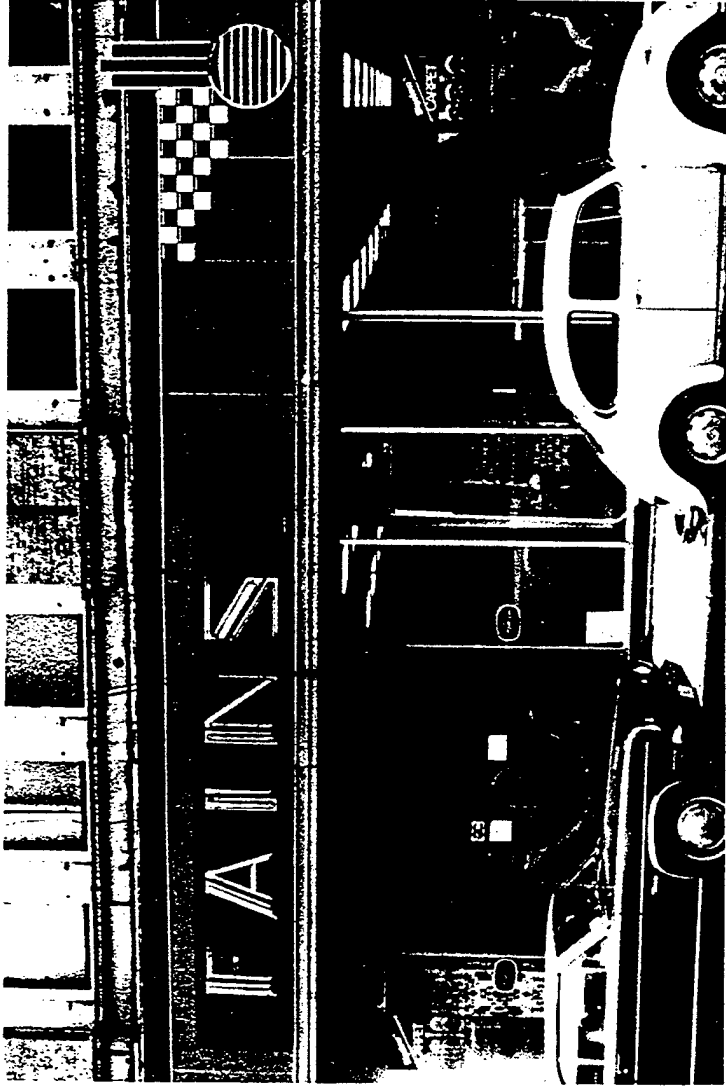

Recommended

Replace

Replacing in kind an entire storefront that is too deteriorated to repair—if the overall form and detailing are still evident—using the physical evidence as a model. If using the same material is not technically or economically feasible, then compatible substitute materials may be considered.

Not Recommended

Removing a storefront that is unrepairable and not replacing it; or replacing it with a new storefront that does not convey the same visual appearance.

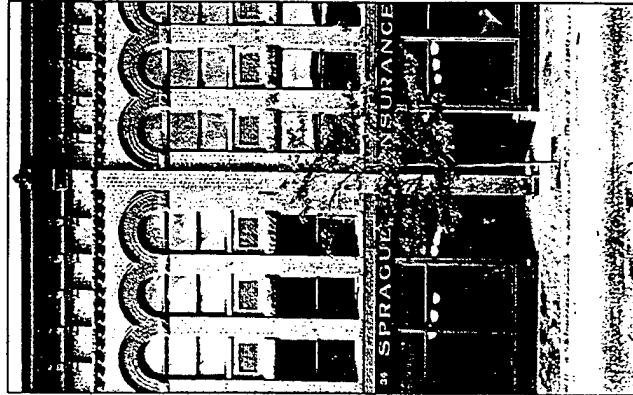

This appropriate new storefront replaces an old one that was too deteriorated to save. It features a recessed doorway based on the historic design and respects the scale and proportion of the existing building.

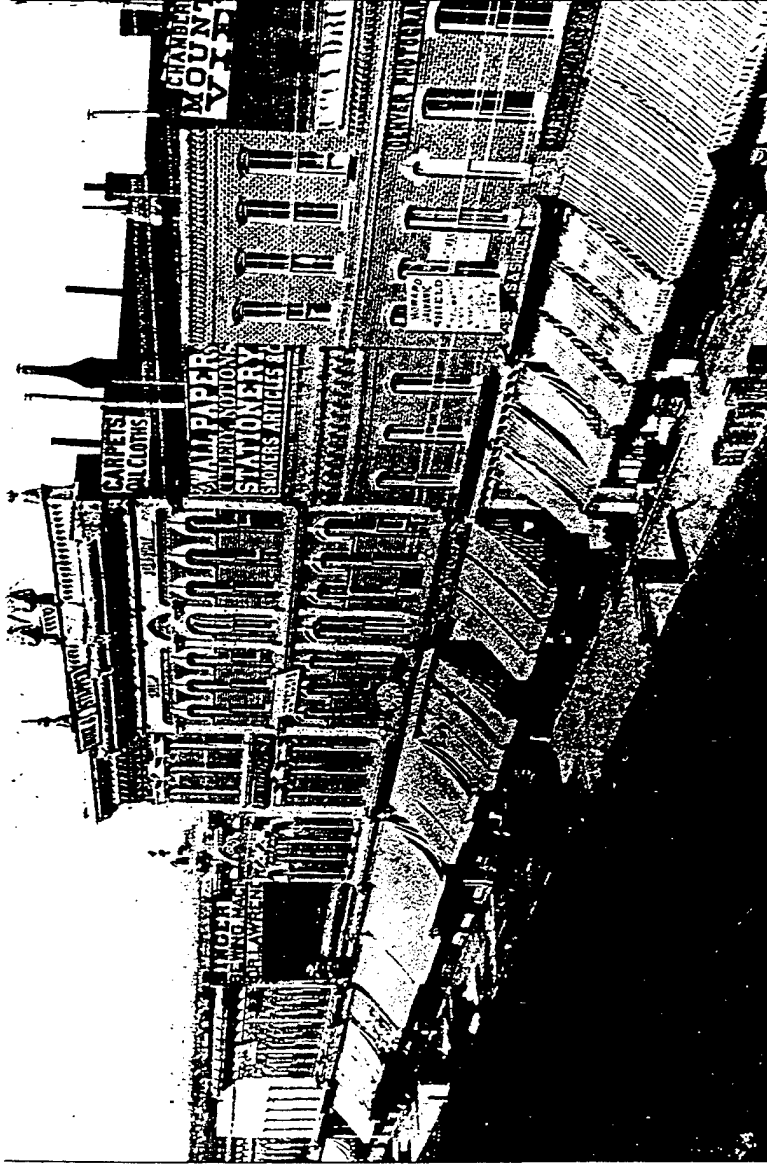

The following work is highlighted to indicate that it represents the particularly complex technical or design aspects of rehabilitation projects and should only be considered after the preservation concerns listed above have been addressed.

Recommended

Design for Missing Historic Features

Designing and constructing a new storefront when the historic storefront is completely missing. It may be an accurate restoration using historical, pictorial, and physical documentation; or be a new design that is compatible with the size, scale, material, and color of the historic building.

Not Recommended

Creating a false historical appearance because the replaced storefront is based on insufficient historical, pictorial, and physical documentation.

Introducing a new design that is incompatible in size, scale, material, and color.

Using inappropriately scaled signs and logos or other types of signs that obscure, damage, or destroy remaining character-defining features of the historic building.

Building
Interior
*Structural
Systems*

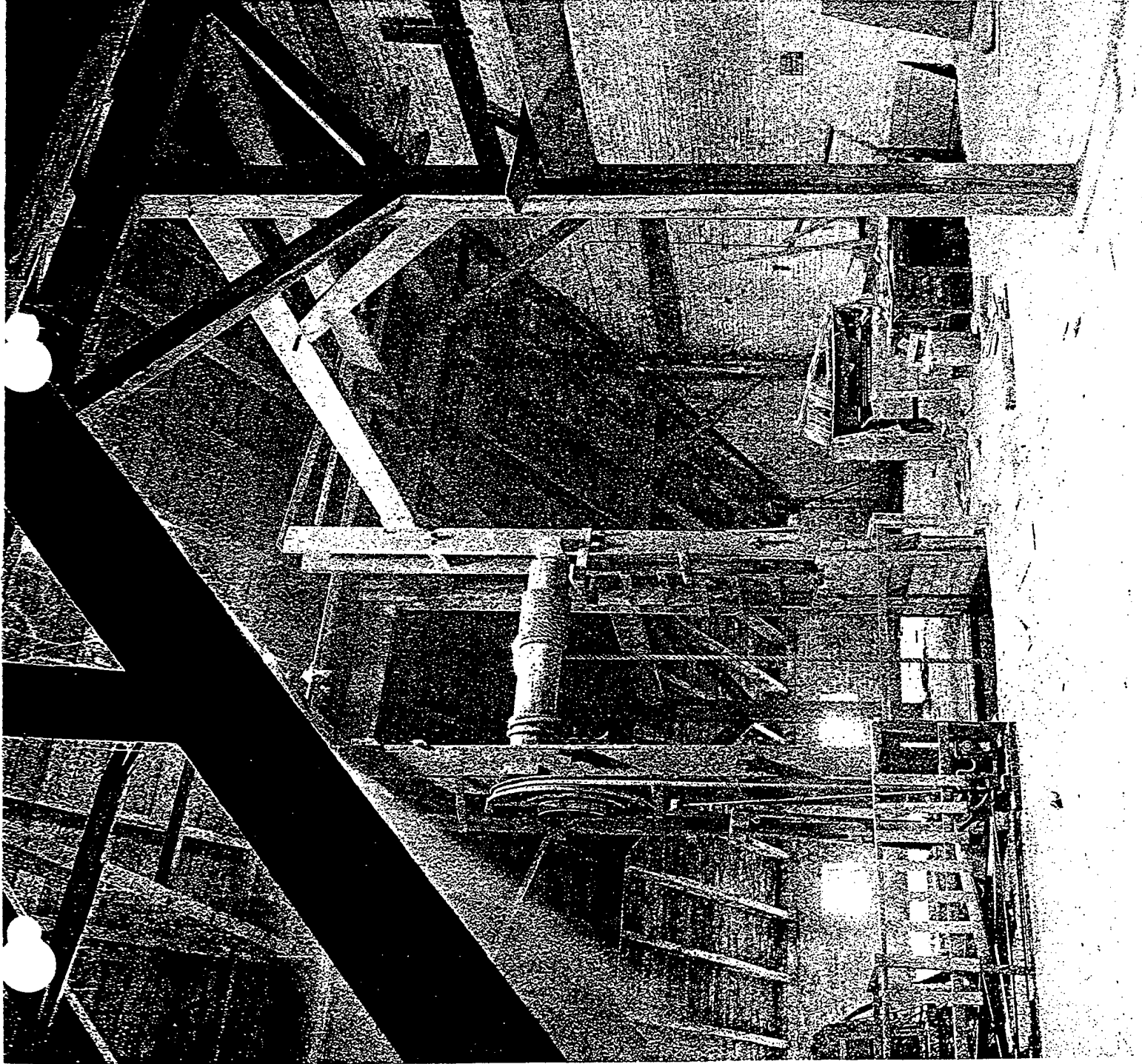

Building Interior *Structural Systems*

If features of the structural system are exposed such as loadbearing brick walls, cast iron columns, roof trusses, posts and beams, vigas, or stone foundation walls, they may be important in defining the building's overall historic character. Unexposed structural features that are not character-defining or an entire structural system may nonetheless be significant in the history of building technology; therefore, the structural system should always be examined and evaluated early in the project planning stage to determine both its physical condition and its importance to the building's historic character or historical significance.

The types of structural systems found in America include, but certainly are not limited, to the

following: wooden frame construction (17th c.), balloon frame construction (19th c.), load-bearing masonry construction (18th c.), brick cavity wall construction (19th c.), heavy timber post and beam industrial construction (19th c.), fireproof iron construction (19th c.), heavy masonry and steel construction (19th c.), skeletal steel construction (19th c.), and concrete slab and post construction (20th c.).

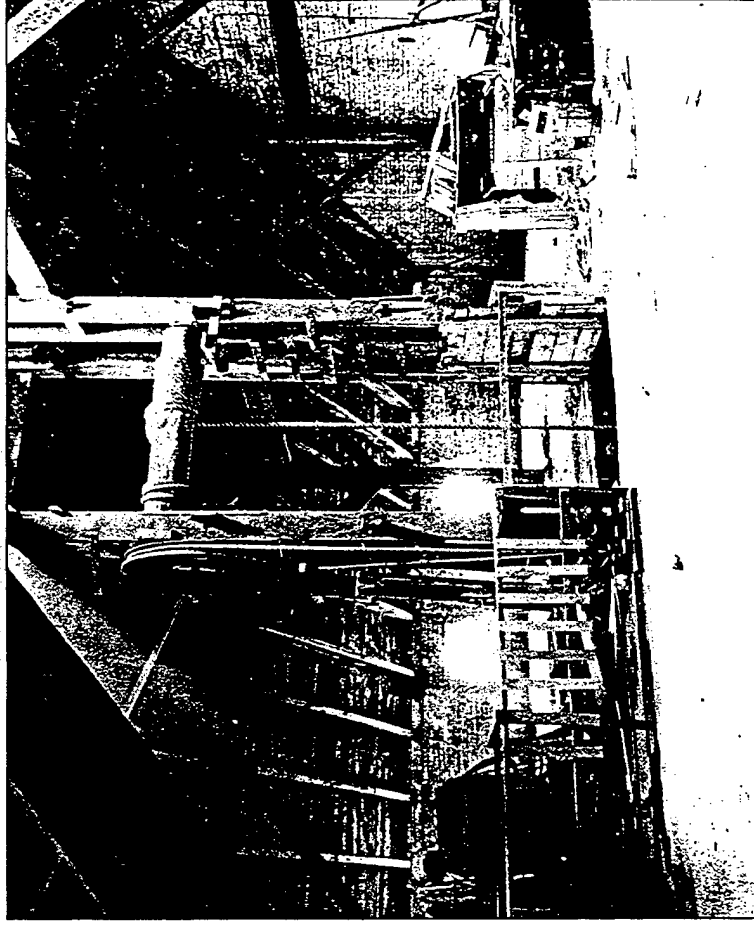

Recommended

Identify, retain, and preserve

Identifying, retaining, and preserving structural systems—and individual features of systems—that are important in defining the overall historic character of the building, such as post and beam systems, trusses, summer beams, vigas, cast iron columns, above-grade stone foundation walls, or loadbearing brick or stone walls.

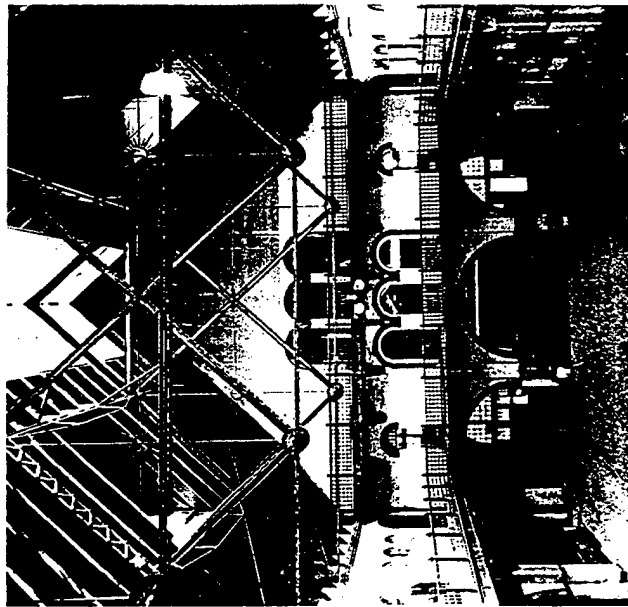

The exposed metal roof-truss system of this waiting room not only provides structural support, but is also important in defining the interior character of the train station.

Protect and maintain

Protecting and maintaining the structural system by cleaning the roof gutters and downspouts; replacing roof flashing; keeping masonry, wood, and architectural metals in a sound condition; and assuring that structural members are free from insect infestation.

Not Recommended

Removing, covering, or radically changing features of structural systems which are important in defining the overall historic character of the building so that, as a result, the character is diminished.

Putting a new use into the building which could overload the existing structural system; or installing equipment or mechanical systems which could damage the structure.

Demolishing a loadbearing masonry wall that could be augmented and retained, and replacing it with a new wall (i.e., brick or stone), using the historic masonry only as an exterior veneer.

Leaving known structural problems untreated such as deflection of beams, cracking and bowing of walls, or racking of structural members.

Utilizing treatments or products that accelerate the deterioration of structural material such as introducing urea-formaldehyde foam insulation into frame walls.

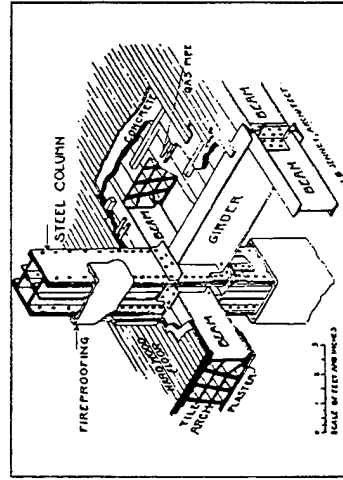

Detail of a column and girder connection and floor construction, The Fair Store, Chicago, Illinois, 1892 (Jenney and Mundie, architects). This type of connection was used in many iron and steel buildings; "fireproofing" was provided by terra-cotta tile and plaster.

Failing to provide proper building maintenance so that deterioration of the structural system results. Causes of deterioration include subsurface ground movement, vegetation growing too close to foundation walls, improper grading, fungal rot, and poor interior ventilation that results in condensation.

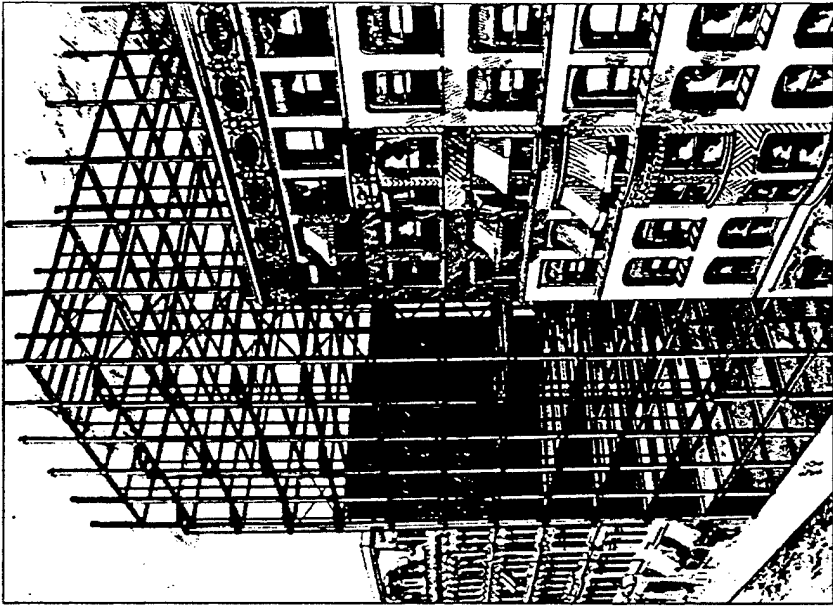

In 1889, James L. Watson, architect, designed the Unity Building, Chicago, Illinois, 1891-1892 (Clinton J. Warren, architect). The development of the skeleton frame was pioneered by architects of the "Chicago School" in the late-19th century. With this method the weight of the building is carried on the frame, not the walls, allowing the construction of taller buildings without increasing the wall thickness.



In order to preserve this historic wood-frame building, new steel framing was inserted to reinforce the wood post and beam structure. Original wood framing members were notched to accommodate the new steel frame.

Photos: Irving B. Haynes and Associates

Recommended

Examining and evaluating the physical condition of the structural system and its individual features using non-destructive techniques such as X-ray photography.

Repair

Repairing the structural system by augmenting or upgrading individual parts or features. For example, weakened structural members such as floor framing can be paired with a new member, braced, or otherwise supplemented and reinforced.

Not Recommended

Utilizing destructive probing techniques that will damage or destroy structural material.

Upgrading the building structurally in a manner that diminishes the historic character of the exterior, such as installing strapping channels or removing a decorative cornice; or that damages interior features or spaces.

Replacing a structural member or other feature of the structural system when it could be augmented and retained.

Recommended

Replace

Replacing in kind—or with substitute material—those portions or features of the structural system that are either extensively deteriorated or are missing when there are surviving prototypes such as cast iron columns, roof rafters or trusses, or sections of loadbearing walls. Substitute material should convey the same form, design, and overall visual appearance as the historic feature; and, at a minimum, equal its loadbearing capabilities.

These before and after rehabilitation photographs offer a good example of a project that took into account, and respected, the unique industrial structural character of this mill building in its conversion to a shopping mall.

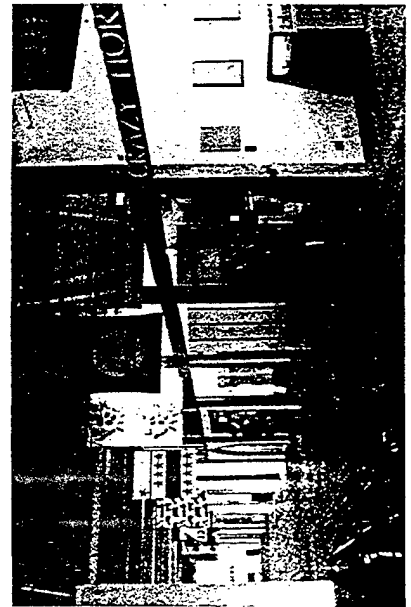
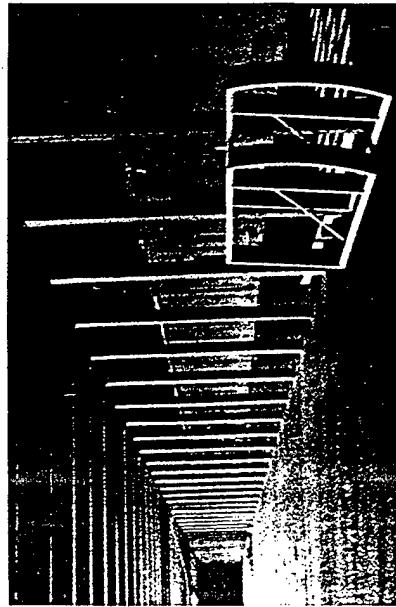

Not Recommended

Installing a replacement feature that does not convey the same visual appearance, e.g., replacing an exposed wood summer beam with a steel beam.

Using substitute material that does not equal the loadbearing capabilities of the historic material and design or is otherwise physically or chemically incompatible.

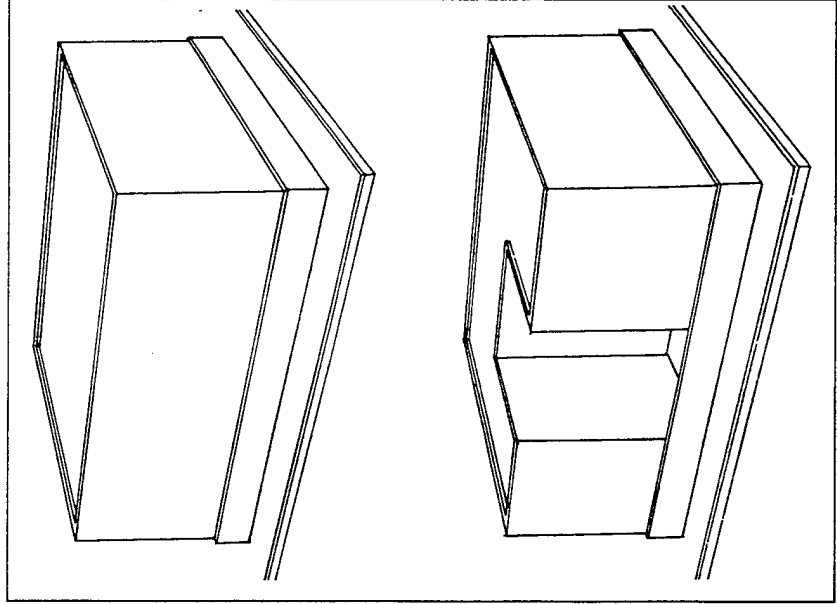

A rehabilitation proposal to convert a historic waterfront warehouse into a residential apartment building called for cutting out a large section of the rectangular-shaped historic building. The new "U" shape would provide more apartments with a waterfront view. This schematic drawing shows the drastic change that would result to the structure and character of the historic building if a portion had been removed as proposed (the project was denied because it did not meet the Standards).

The following work is highlighted to indicate that it represents the particularly complex technical or design aspects of rehabilitation projects and should only be considered after the preservation concerns listed above have been addressed.

Recommended

Alterations/Additions for the New Use

Limiting any new excavations adjacent to historic foundations to avoid undermining the structural stability of the building or adjacent historic buildings. Studies should be done to ascertain potential damage to archeological resources.

Correcting structural deficiencies in preparation for the new use in a manner that preserves the structural system and individual character-defining features.

Designing and installing new mechanical or electrical systems when required for the new use which minimize the number of cutouts or holes in structural members.

Adding a new floor when required for the new use if such an alteration does not damage or destroy the structural system or obscure, damage, or destroy character-defining spaces, features, or finishes.

Creating an atrium or a light well to provide natural light when required for the new use in a manner that assures the preservation of the structural system as well as character-defining interior spaces, features, and finishes.

Not Recommended

Carrying out excavations or regrading adjacent to or within a historic building which could cause the historic foundation to settle, shift, or fail; could have a similar effect on adjacent historic buildings; or could destroy significant archeological resources.

Radically changing interior spaces or damaging or destroying features or finishes that are character-defining while trying to correct structural deficiencies in preparation for the new use.

Installing new mechanical and electrical systems or equipment in a manner which results in numerous cuts, splices, or alterations to the structural members.

Inserting a new floor when such a radical change damages a structural system or obscures or destroys interior spaces, features, or finishes.

Inserting new floors or furred-down ceilings which cut across the glazed areas of windows so that the exterior form and appearance of the windows are radically changed.

Damaging the structural system or individual features; or radically changing, damaging, or destroying character-defining interior spaces, features, or finishes in order to create an atrium or a light well.

Building
Interior
*Spaces,
Features
and Finishes*

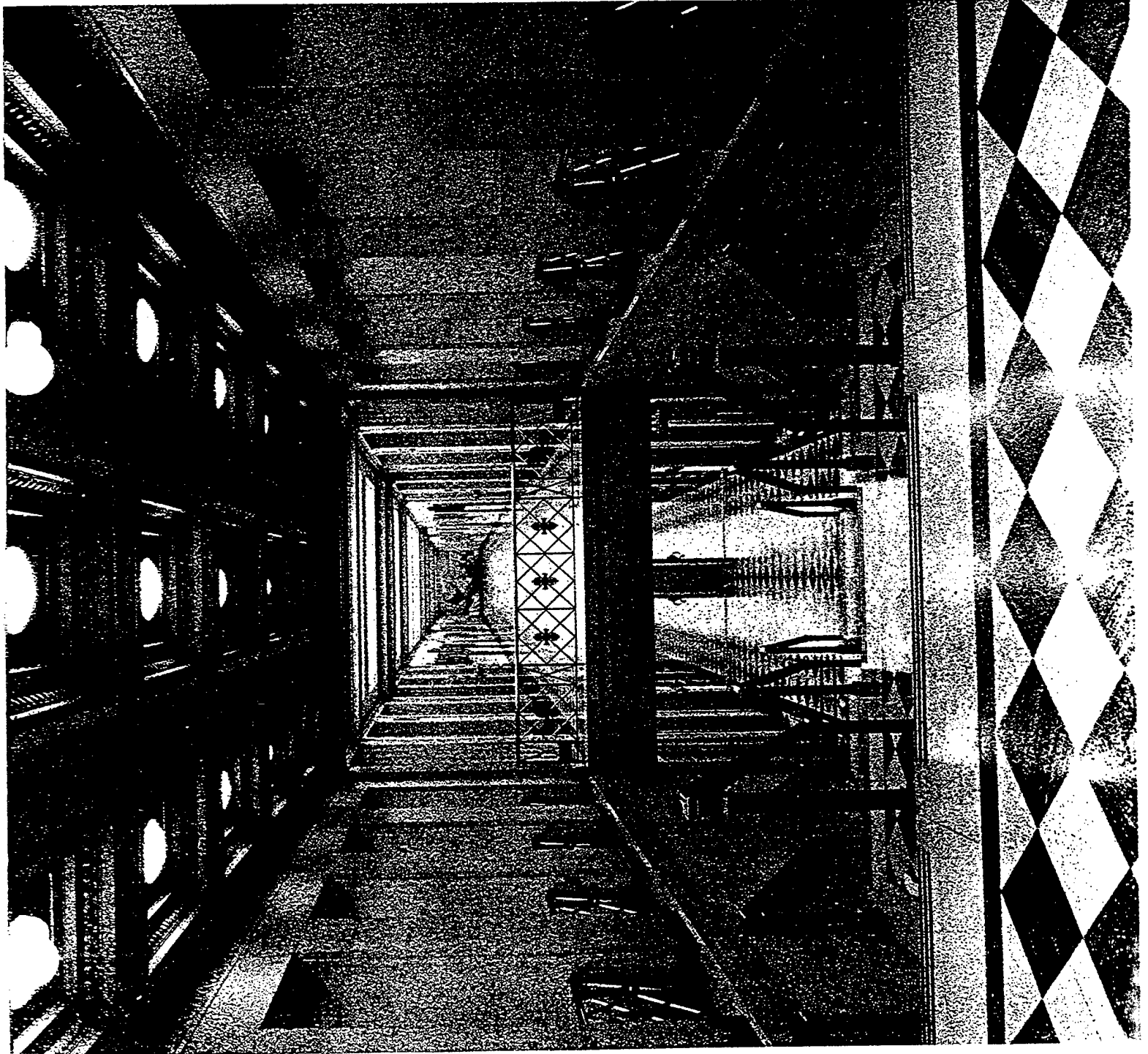

Building Interior

Spaces, Features and Finishes

An interior floor plan, the arrangement and sequence of spaces, and built-in features and applied finishes are individually and collectively important in defining the historic character of the building. Their identification, retention, protection, and repair should be given prime consideration in every rehabilitation project. In evaluating historic interiors prior to rehabilitation, it should be kept in mind that interiors are comprised of a series of primary and secondary spaces. This is applicable to all buildings, from courthouses to cathedrals, to cottages and office buildings. Primary spaces, including entrance halls, parlors, or living rooms, assembly rooms and lobbies, are defined not only by their features and finishes, but by the size and proportion of the rooms themselves—purposefully

created to be the visual attraction or functioning “core” of the building. Care should be taken to retain the essential proportions of primary interior spaces and not to damage, obscure, or destroy distinctive features and finishes.

Secondary spaces include areas and rooms that “service” the primary spaces and may include kitchens, bathrooms, mail rooms, utility spaces, hallways, fire stairs and work spaces in a commercial or office building. Extensive changes can often be made in these less important areas without having a detrimental effect on the overall historic character.



Recommended

Interior Spaces

Identify, retain and preserve

Identifying, retaining, and preserving a floor plan or interior spaces that are important in defining the overall historic character of the building. This includes the size, configuration, proportion, and relationship of rooms and corridors; the relationship of features to spaces; and the spaces themselves such as lobbies, reception halls, entrance halls, double parlors, theaters, auditoriums, and important industrial or commercial use spaces.

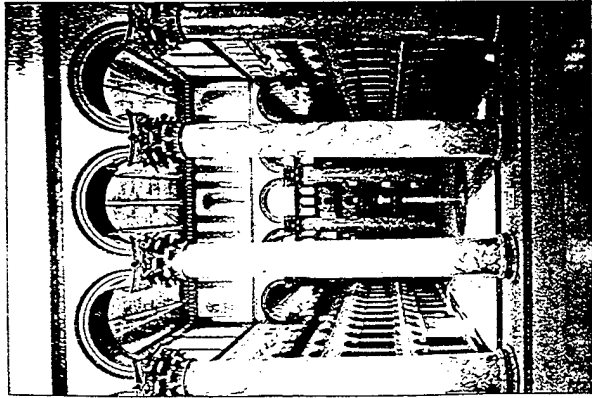

Interior Features and Finishes

Identify, retain and preserve

Identifying, retaining, and preserving interior features and finishes that are important in defining the overall historic character of the building, including columns, cornices, baseboards, fireplaces and mantels, panelling, light fixtures, hardware, and flooring; and wallpaper, plaster, paint, and finishes such as stenciling, marbling, and graining; and other decorative materials that accent interior features and provide color, texture, and patterning to walls, floors, and ceilings.

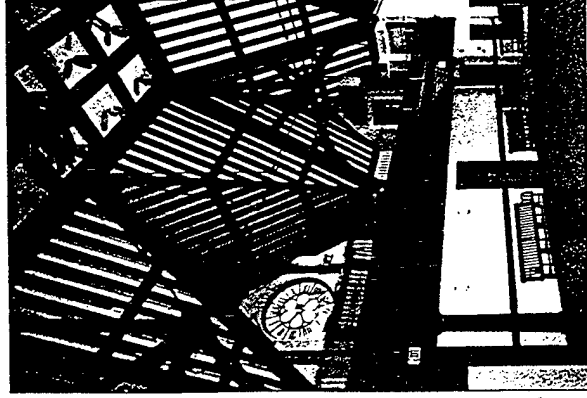

These photographs suggest the richness and diversity of public building spaces, features, and finishes.

Not Recommended

Radically changing a floor plan or interior spaces—including individual rooms—which are important in defining the overall historic character of the building so that, as a result, the character is diminished.

Altering the floor plan by demolishing principal walls and partitions to create a new appearance.

Altering or destroying interior spaces by inserting floors, cutting through floors, lowering ceilings, or adding or removing walls.

Relocating an interior feature such as a staircase so that the historic relationship between features and space is altered.

Removing or radically changing features and finishes which are important in defining the overall historic character of the building so that, as a result, the character is diminished.

Installing new decorative material that obscures or damages character-defining interior features or finishes.

Removing paint, plaster, or other finishes from historically finished surfaces to create a new appearance (e.g., removing plaster to expose masonry surfaces such as brick walls or a chimney piece).

Applying paint, plaster, or other finishes to surfaces that have been historically unfinished to create a new appearance.

Stripping paint to bare wood rather than repairing or reapplying grained or marbled finishes to features such as doors and panelling.

Radically changing the type of finish or its color, such as painting a previously varnished wood feature.

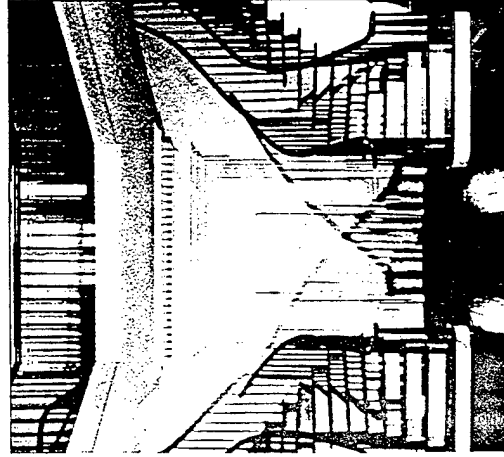
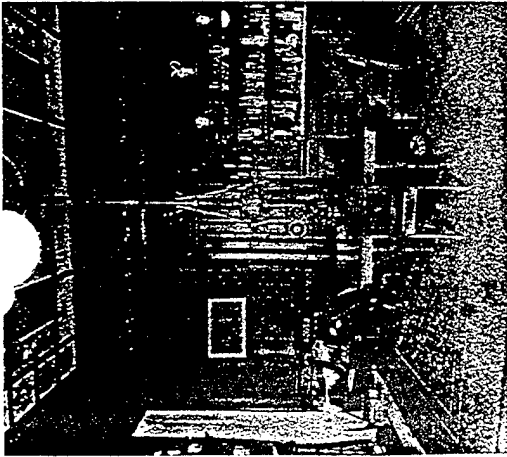

Photo: Jack E. Boucher, HAIBS.

This historic character of these 19th century residential interiors was protected and maintained during rehabilitation.

Recommended

Protect and maintain

Protecting and maintaining masonry, wood, and architectural metals which comprise interior features through appropriate surface treatments such as cleaning, rust removal, limited paint removal, and reapplication of protective coating systems.

Protecting interior features and finishes against arson and vandalism before project work begins, erecting protective fencing, boarding-up windows, and installing fire alarm systems that are keyed to local protection agencies.

Protecting interior features such as a staircase, mantel, or decorative finishes and wall coverings against damage during project work by covering them with heavy canvas or plastic sheets.

Installing protective coverings in areas of heavy pedestrian traffic to protect historic features such as wall coverings, parquet flooring and panelling.

Removing damaged or deteriorated paints and finishes to the next sound layer using the gentlest method possible, then repainting or refinishing using compatible paint or other coating systems.

Repainting with colors that are appropriate to the historic building.

Not Recommended

Failing to provide adequate protection to materials on a cyclical basis so that deterioration of interior features results.

Permitting entry into historic buildings through unsecured or broken windows and doors so that the interior features and finishes are damaged by exposure to weather or through vandalism.

Stripping interiors of features such as woodwork, doors, windows, light fixtures, copper piping, radiators; or of decorative materials.

Failing to provide proper protection of interior features and finishes during work so that they are gouged, scratched, dented, or otherwise damaged.

Failing to take new use patterns into consideration so that interior features and finishes are damaged.

Using destructive methods such as propane or butane torches or sandblasting to remove paint or other coatings. These methods can irreversibly damage the historic materials that comprise interior features.

Using new paint colors that are inappropriate to the historic building.

Recommended

Limiting abrasive cleaning methods to certain industrial or warehouse buildings where the interior masonry or plaster features do not have distinguishing design, detailing, tooling, or finishes; and where wood features are not finished, molded, beaded, or worked by hand. Abrasive cleaning should *only* be considered after other, gentler methods have been proven ineffective.

Evaluating the overall condition of materials to determine whether more than protection and maintenance are required, that is, if repairs to interior features and finishes will be necessary.

Furring out exterior walls to add insulation and suspending new ceilings to hide ductwork and wiring can change a room's proportions and can also destroy or obscure significant decorative detailing.

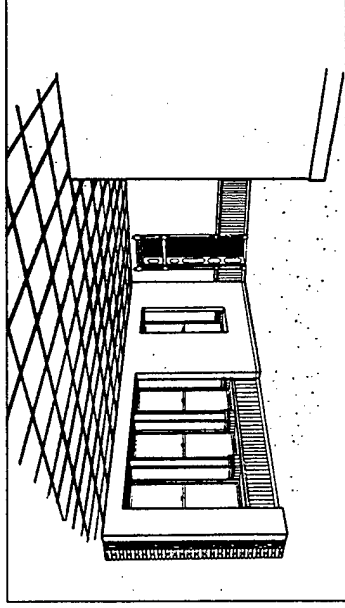
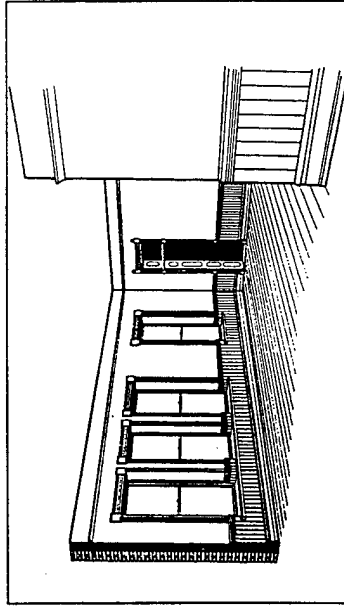

Not Recommended

Changing the texture and patina of character-defining features through sandblasting or use of abrasive methods to remove paint, discoloration or plaster. This includes both exposed wood (including structural members) and masonry.

Failing to undertake adequate measures to assure the protection of interior features and finishes.

Repair

Repairing interior features and finishes by reinforcing the historic materials. Repair will also generally include the limited replacement in kind—or with compatible substitute material—of those extensively deteriorated or missing parts of repeated features when there are surviving prototypes such as stairs, balustrades, wood panelling, columns; or decorative wall coverings or ornamental tin or plaster ceilings.

Replacing an entire interior feature such as a staircase, paneled wall, parquet floor, or cornice; or finish such as a decorative wall covering or ceiling when repair of materials and limited replacement of such parts are appropriate.

Using a substitute material for the replacement part that does not convey the visual appearance of the surviving parts or portions of the interior feature or finish or that is physically or chemically incompatible.

Recommended

Replace

Replacing in kind an entire interior feature or finish that is too deteriorated to repair—if the overall form and detailing are still evident—using the physical evidence as a model for reproduction. Examples could include wainscoting, a tin ceiling, or interior stairs. If using the same kind of material is not technically or economically feasible, then a compatible substitute material may be considered.

Before and after: Prior to rehabilitation of this hotel, water intrusion and freeze-thaw cycles had caused extensive efflorescence and plaster failure. The ornamental plaster was almost fully re-manufactured, then gilded. Light fixtures and other detailing were also carefully replicated.

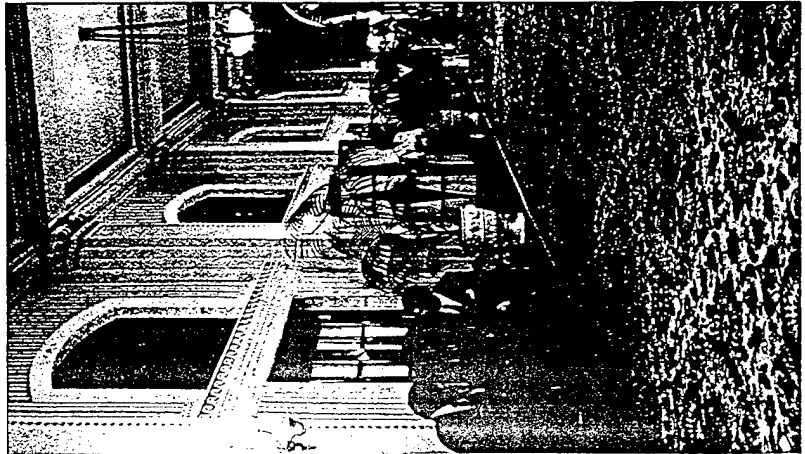
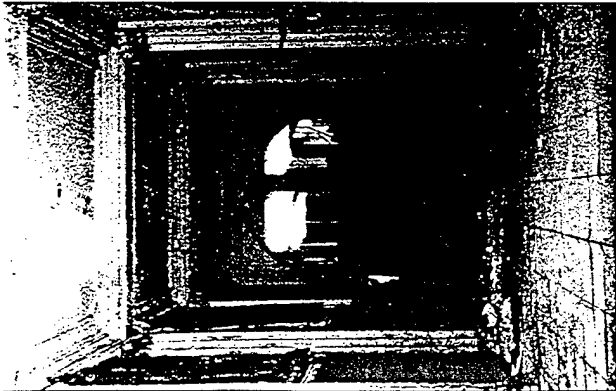

Not Recommended

Removing a character-defining feature or finish that is unrepairable and not replacing it; or replacing it with a new feature or finish that does not convey the same visual appearance.

During rehabilitation, the historic plaster was removed from perimeter walls, leaving the brick exposed; in addition historically painted wood trim was stripped. Removing finishes not only destroys historic materials that should be retained and preserved, but it also gives the interior an appearance it never had historically.

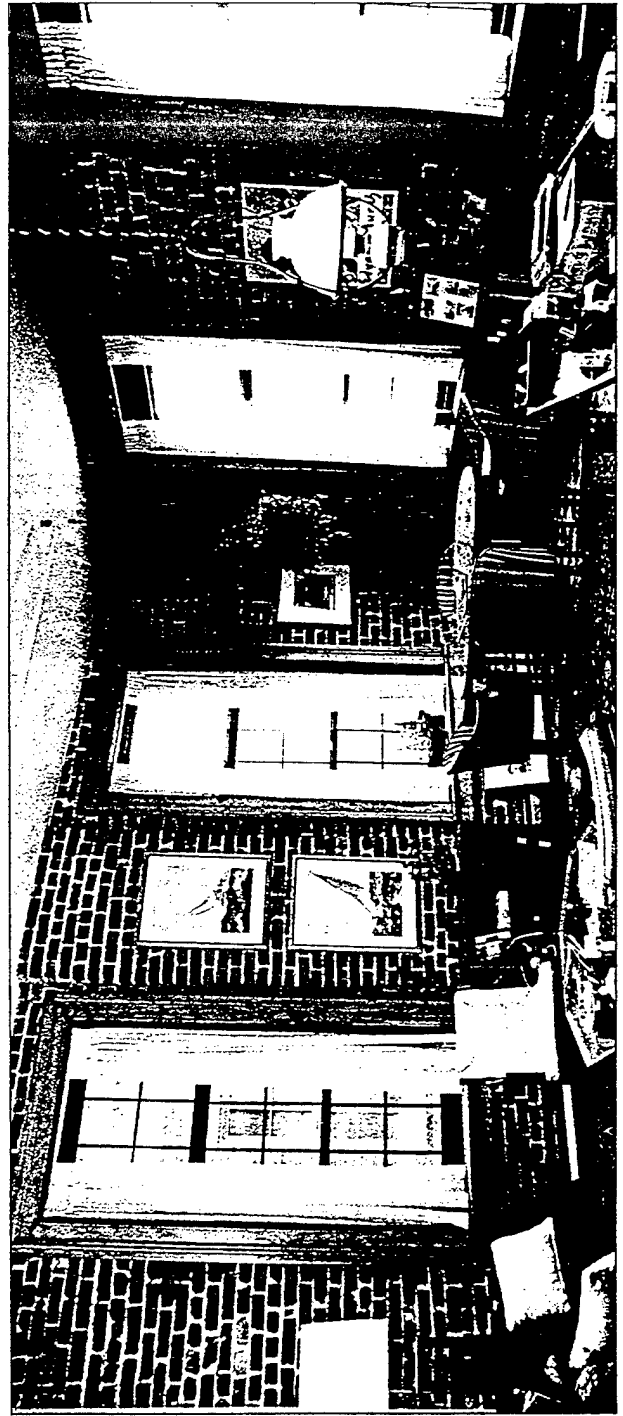

The following work is highlighted to indicate that it represents the particularly complex technical or design aspects of rehabilitation projects and should only be considered after the preservation concerns listed above have been addressed.

Recommended

Design for Missing Historic Features

Designing and installing a new interior feature or finish if the historic feature or finish is completely missing. This could include missing partitions, stairs, elevators, lighting fixtures, and wall coverings; or even entire rooms if all historic spaces, features, and finishes are missing or have been destroyed by inappropriate "renovations." The design may be a restoration based on historical, pictorial, and physical documentation; or be a new design that is compatible with the historic character of the buildings, district, or neighborhood.

Alterations/Additions for the New Use

Accommodating service functions such as bathrooms, mechanical equipment, and office machines required by the building's new use in secondary spaces such as first floor service areas or on upper floors.

Reusing decorative material or features that have had to be removed during the rehabilitation work including wall and baseboard trim, door molding, panelled doors, and simple wainscoting; and relocating such material or features in areas appropriate to their historic placement.

Installing permanent partitions in secondary spaces; removable partitions that do not destroy the sense of space should be installed when the new use requires the subdivision of character-defining interior space.

Not Recommended

Creating a false historical appearance because the replaced feature is based on insufficient physical, historical, and pictorial documentation or on information derived from another building.

Introducing a new interior feature or finish that is incompatible with the scale, design, materials, color, and texture of the surviving interior features and finishes.

Dividing rooms, lowering ceilings, and damaging or obscuring character-defining features such as fireplaces, niches, stairways or alcoves, so that a new use can be accommodated in the building.

Discarding historic material when it can be reused within the rehabilitation project or relocating it in historically inappropriate areas.

Installing permanent partitions that damage or obscure character-defining spaces, features, or finishes.

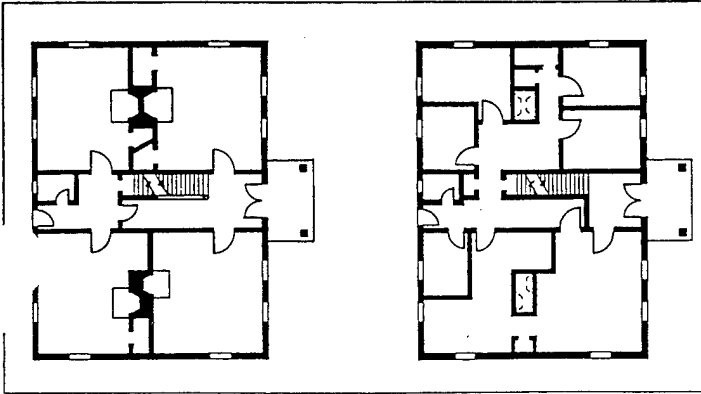

Adding several new rooms to a distinctive interior space may radically change its historic character. Before (top): The original plan was a central hall with four large, equally-sized rooms around it. Each room had a fireplace with a mantel and decorative trim. After (bottom): During rehabilitation, numerous small rooms were added; the open stair was also replaced with a boxed-in stair and the original trim and fireplaces were removed.

Recommended

Alterations/Additions for the New Use

Enclosing an interior stairway where required by code so that its character is retained. In many cases, glazed fire-rated walls may be used.

Placing new code-required stairways or elevators in secondary and service areas of the historic building.

Creating an atrium or a light well to provide natural light when required for the new use in a manner that preserves character-defining interior spaces, features, and finishes as well as the structural system.

Adding a new floor if required for the new use in a manner that preserves character-defining structural features, and interior spaces, features, and finishes.

Not Recommended

Enclosing an interior stairway with fire-rated construction so that the stairwell space or any character-defining features are destroyed.

Radically changing, damaging, or destroying character-defining spaces, features, or finishes when adding new code-required stairways and elevators.

Destroying character-defining interior, spaces, features, or finishes; or damaging the structural system in order to create an atrium or light well.

Inserting a new floor within a building that alters or destroys the fenestration; radically changes a character-defining interior space; or obscures, damages, or destroys decorative detailing.

Building
Interior

*Mechanical
Systems*

HEATING
AIR CONDITIONING
ELECTRICAL
AND PLUMBING

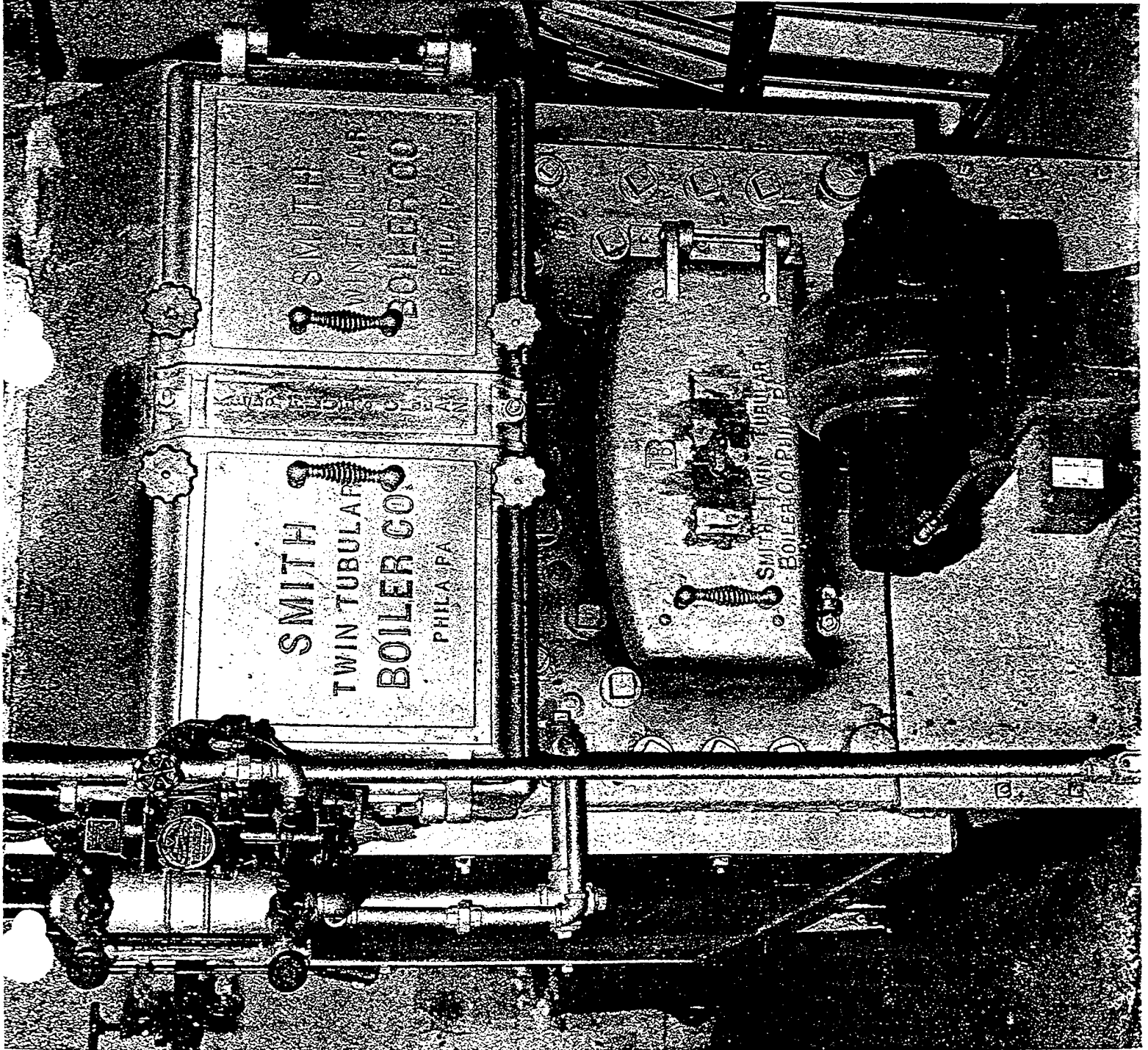

Building Interior

Mechanical Systems

Mechanical, lighting and plumbing systems improved significantly with the coming of the Industrial Revolution. The 19th century interest in hygiene, personal comfort, and the reduction of the spread of disease was met with the development of central heating, piped water, piped gas, and networks of underground cast iron sewers. Vitreous tiles in kitchens, baths and hospitals could be cleaned easily and regularly. The mass production of cast iron radiators made central heating affordable to many; some radiators were elaborate and included special warming chambers for plates or linens. Ornamental grilles and registers provided decorative covers for functional heaters in public spaces. By the turn of the 20th century, it was common to have all of these modern amenities in a building.

The greatest impact of the 20th century on mechanical systems was the use of electricity for interior lighting, forced air ventilation, elevators for tall buildings, exterior lighting and electric heat. The new age of technology brought an increasingly high level

of design and decorative art to the functional elements of mechanical, electrical and plumbing systems.

The visible decorative features of historic mechanical systems such as grilles, lighting fixtures, and ornamental switchplates may contribute to the overall historic character of the building and should thus be retained and repaired, whenever possible. Their identification needs to take place together with an evaluation of their physical condition early in project planning. On the other hand, the functioning parts of many older systems, such as compressors and their ductwork, and wiring and pipes may often need to be upgraded or entirely replaced in order to accommodate the new use and to meet code requirements.

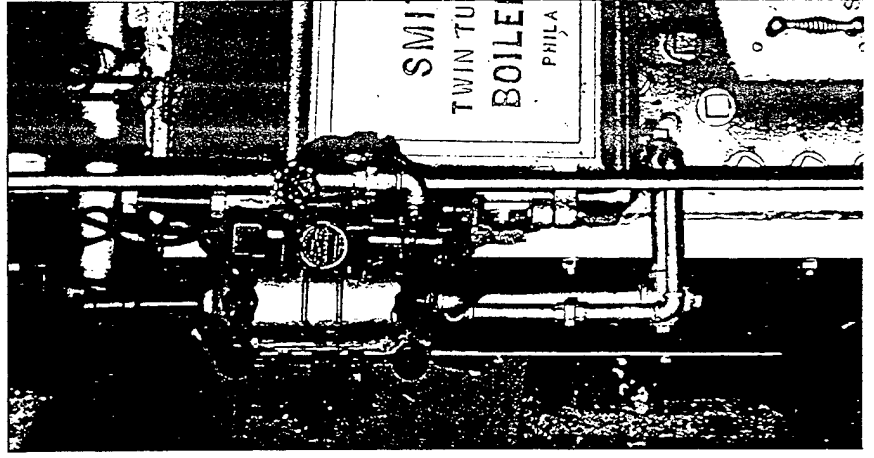

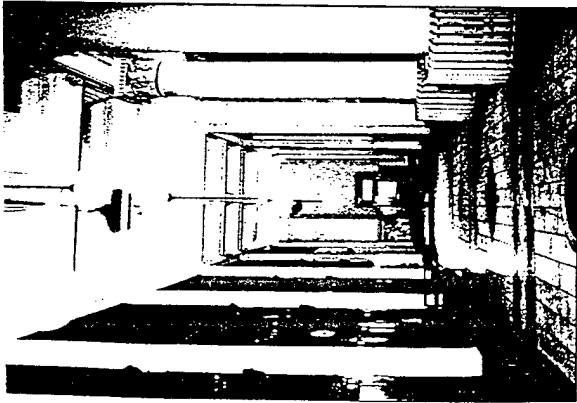

The visible features of historic mechanical systems, such as heating, lighting, and plumbing, may sometimes help define the overall character of an interior.

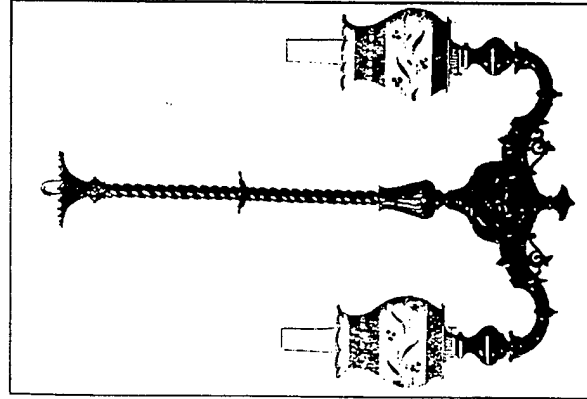

A gaslight may be converted for electrical use to extend its functional and decorative life.

Recommended

Identify, retain and preserve

Identifying, retaining, and preserving visible features of early mechanical systems that are important in defining the overall historic character of the building, such as radiators, vents, fans, grilles, plumbing fixtures, switchplates, and lights.

Not Recommended

Removing or radically changing features of mechanical systems that are important in defining the overall historic character of the building so that, as a result, the character is diminished.



The bronze elevator doors and light coffers play an important decorative role in this early-20th century administrative building.

Photo: Brooks Photographers, HABS Collection.

Protect and maintain

Protecting and maintaining mechanical, plumbing, and electrical systems and their features through cyclical cleaning and other appropriate measures.

Failing to provide adequate protection of materials on a cyclical basis so that deterioration of mechanical systems and their visible features results.

Preventing accelerated deterioration of mechanical systems by providing adequate ventilation of attics, crawlspaces, and cellars so that moisture problems are avoided.

Enclosing mechanical systems in areas that are not adequately ventilated so that deterioration of the systems results.

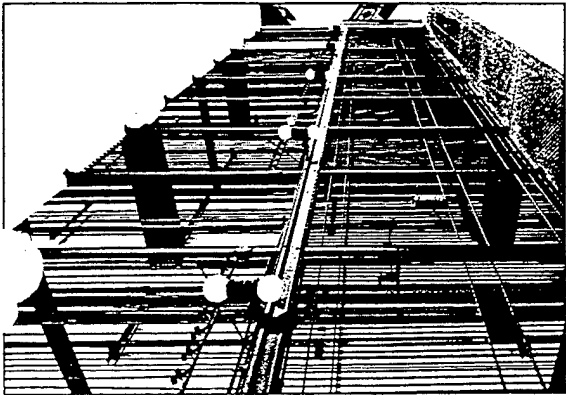

Photo: Richard Nickel

Both function and design elegance are evident in this row of cast iron elevator cages and light fixtures adorning an early-20th century commercial building.

Recommended

Improving the energy efficiency of existing mechanical systems to help reduce the need for elaborate new equipment. Consideration should be given to installing storm windows, insulating attic crawl space, or adding awnings, if appropriate.

Not Recommended

Installing unnecessary air conditioning or climate control systems which can add excessive moisture to the building. This additional moisture can either condense inside, damaging interior surfaces, or pass through interior walls to the exterior, potentially damaging adjacent materials as it migrates.

Repair

Repairing mechanical systems by augmenting or upgrading system parts, such as installing new pipes and ducts; rewiring; or adding new compressors or boilers.

Replacing a mechanical system or its functional parts when it could be upgraded and retained.

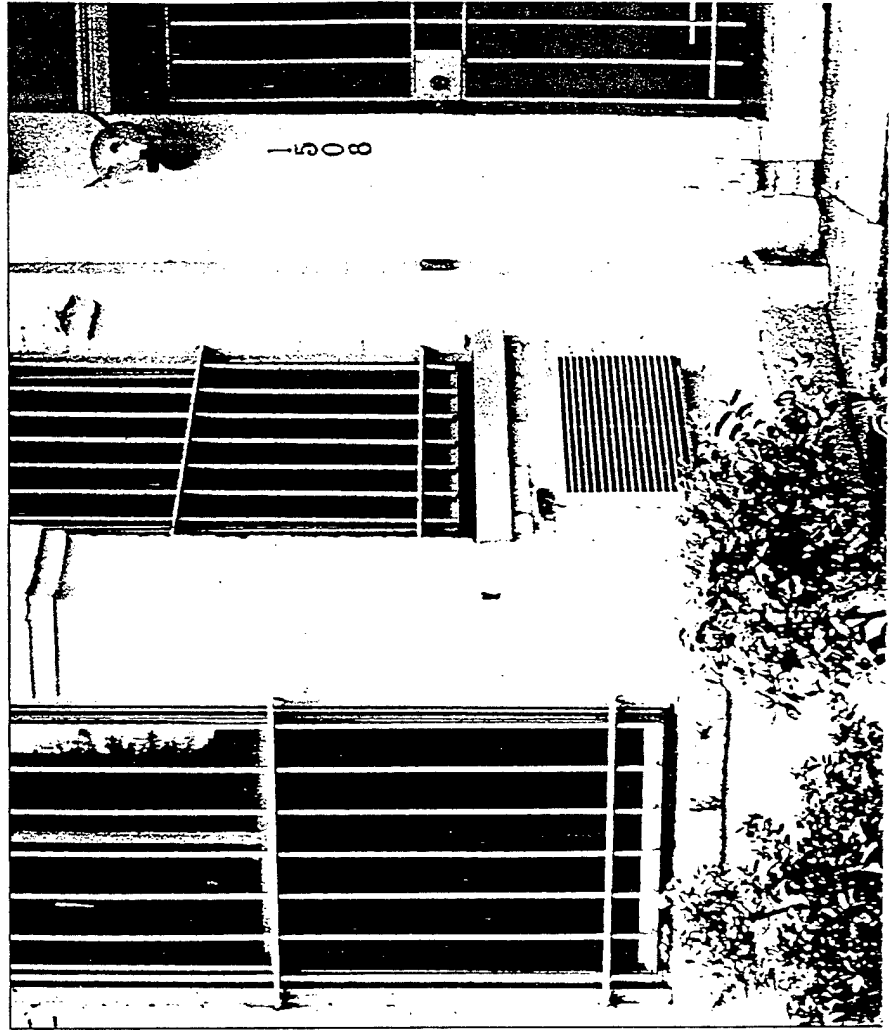

The historic window on a primary facade has been shortened and the area below it filled in with brick in order to install a through-the-wall air conditioning unit. In addition to changing the window size and destroying the sill, the unit itself is visually obtrusive.

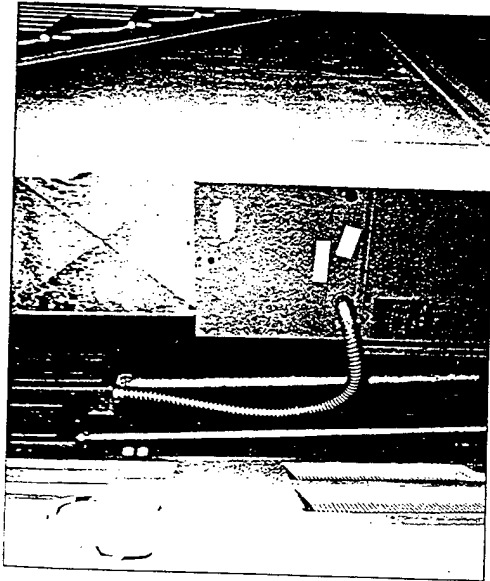

When a late-19th century single-family house was converted to four rental units, the new HVAC system was installed under the central stair. When the door is closed, only the vents indicate its presence.

Recommended

Replace

Replacing in kind—or with compatible substitute material—those visible features of mechanical systems that are either extensively deteriorated or are prototypes such as ceiling fans, switchplates, radiators, grilles, or plumbing fixtures.

This row of hanging fluorescent lights installed in an earlier renovation mars an otherwise classically detailed interior. They have also caused the historic beaded ceiling to pull away from the joists.

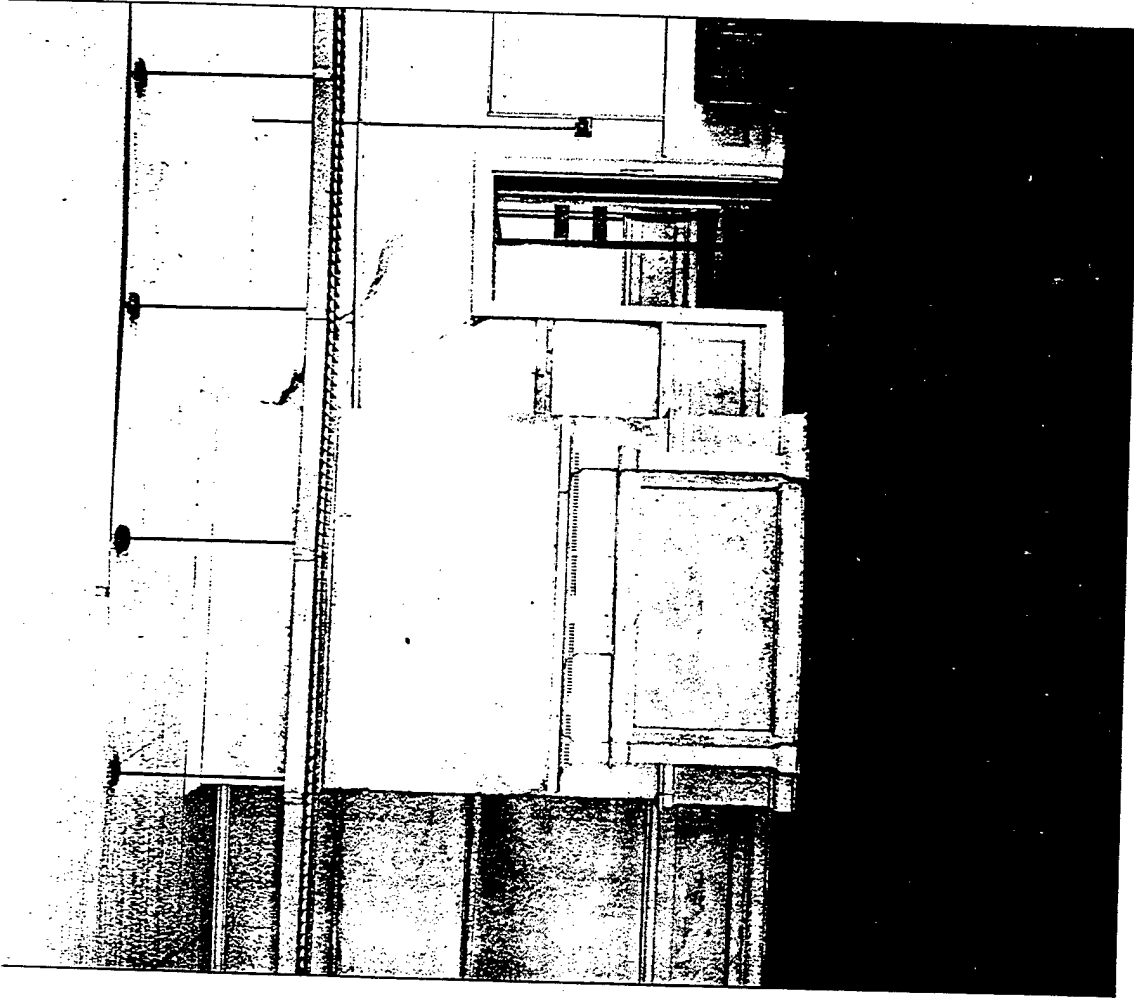

Not Recommended

Installing a replacement feature that does not convey the same visual appearance.

The following work is highlighted to indicate that it represents the particularly complex technical or design aspects of rehabilitation projects and should only be considered after the preservation concerns listed above have been addressed.

Recommended

Alterations/Additions for the New Use

Installing a completely new mechanical system if required for the new use so that it causes the least alteration possible to the building's floor plan, the exterior elevations, and the least damage to the historic building material.

Providing adequate structural support for new mechanical equipment.

Installing the vertical runs of ducts, pipes, and cables in closets, service rooms, and wall cavities.

Installing air conditioning units if required by the new use in such a manner that historic features are not damaged or obscured and excessive moisture is not generated that will accelerate deterioration of historic materials.

Installing heating/air conditioning units in the window frames in such a manner that the sash and frames are protected. Window installations should be considered only when all other viable heating/cooling systems would result in significant damage to historic materials.

Not Recommended

Installing a new mechanical system so that character-defining structural or interior features are radically changed, damaged, or destroyed.

Failing to consider the weight and design of new mechanical equipment so that, as a result, historic structural members or finished surfaces are weakened or cracked.

Installing vertical runs of ducts, pipes, and cables in places where they will obscure character-defining features.

Concealing mechanical equipment in walls or ceilings in a manner that requires the removal of historic building material.

Installing "dropped" acoustical ceiling to hide mechanical equipment when this destroys the proportions of character-defining interior spaces.

Cutting through features such as masonry walls in order to install air conditioning units.

Radically changing the appearance of the historic building or damaging or destroying windows by installing heating/air conditioning units in historic window frames.

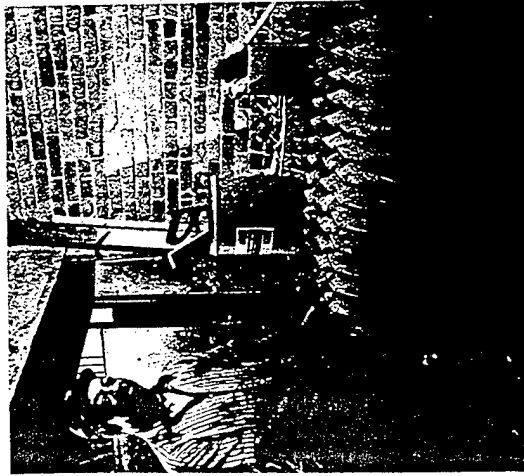

Building Site



Building Site

The landscape surrounding a historic building and contained within an individual parcel of land is considered the building site. The site, including its associated features, contributes to the overall character of the historic property. As a result, the relationship between the buildings and landscape features within the site's boundaries should be considered in the overall planning for rehabilitation project work.

Landscapes which contain historic buildings are found in rural, suburban, and urban communities and reflect environmental influences such as climate as well as the historic period in which they were created. Landscapes created for functional purposes as well as aesthetic enjoyment have been a part of American history since European settlement. Historic American styles in landscape design developed from 17th-18th century Spanish and Colonial gardens, evolving into the pastoral and picturesque design of the 19th century. Victorian carpet bedding, popular during the late 19th century, produced profuse plantings of annuals and

perennials. Later, the early 20th century yielded a return to classical traditions, with revival gardens reflecting European renaissance design.

The building site may be significant in its own right, or derive its significance simply from its association with the historic structure. The level of significance, association, integrity, and condition of the building site may influence the degree to which the existing landscape features should be retained during the rehabilitation project. In an industrial property, the site may be defined simply as the relationship between buildings or between the ground plane and open space and its associated buildings. Designed historic landscapes significant in the field of landscape architecture require a more detailed analysis of their character-defining features which may include lawns, hedges, walks, drives, fences, walls, terraces, water features, topography (grading) and furnishings. Vegetation is an important feature in landscapes; this material, including both native species and cultivated

plants, creates an appearance that is constantly changing, both seasonally and annually. Since most plant material is adapted to specific environments, the character of landscapes varies dramatically in different climates, elevations and regions.

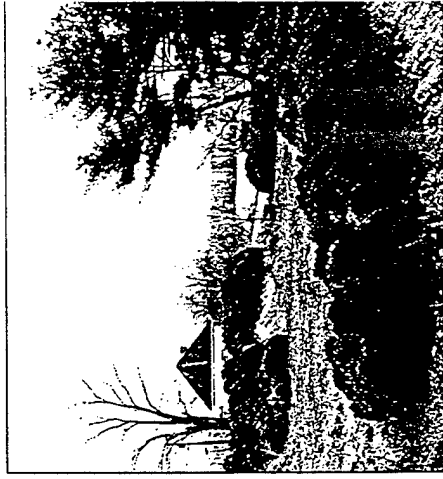

Recommended

Identify, retain and preserve

Identifying, retaining, and preserving buildings and their features as well as features of the site that are important in defining its overall historic character. Site features may include circulation systems such as walks, paths, roads, or parking; vegetation such as trees, shrubs, fields, or herbaceous plant material; landforms such as terracing, berms or gradings; furnishings such as lights, fences, or benches; decorative elements such as sculpture, statuary or monuments; water features including fountains, streams, pools, or lakes; and subsurface archeological features which are important in defining the history of the site.

The stream and circular wagon approach are important features of this historic mill site.

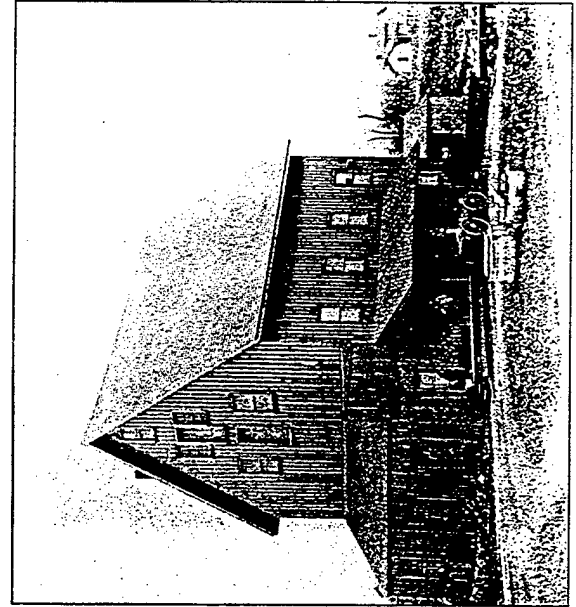

Retaining the historic relationship between buildings and the landscape.

Not Recommended

Removing or radically changing buildings and their features or site features which are important in defining the overall historic character of the property so that, as a result, the character is diminished.

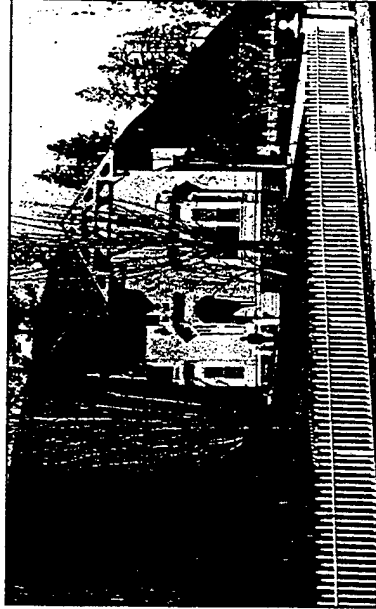

Landscape features that are important in defining the historic character of a building site may include fences, walks, and small outbuildings, as well as trees, bushes and topography that may be unique, such as the hill behind the house.

Photo: Courtesy, Whitman County Historical Society, Inc., Pullman, Washington.

Removing or relocating buildings or landscape features thus destroying the historic relationship between buildings and the landscape.

Removing or relocating historic buildings on a site or in a complex of related historic structures—such as a mill complex or farm—thus diminishing its historic character.

Moving buildings onto the site, thus creating a false historical appearance.

Radically changing the grade level of the site. For example, changing the grade adjacent to a building to permit development of a formerly below-grade area that would drastically change the historic relationship of the building to its site.

Recommended

Providing proper drainage to assure that water does not erode foundation walls; drain toward the building; or damage or erode the landscape.

Minimizing disturbance of terrain around buildings or elsewhere on the site, thus reducing the possibility of destroying or damaging important landscape features or archeological resources.

Surveying and documenting areas where the terrain will be altered to determine the potential impact to important landscape features or archeological resources.

Not Recommended

Failing to maintain adequate site drainage so that buildings and site features are damaged or destroyed; or alternatively, changing the site grading so that water no longer drains properly.

Introducing heavy machinery into areas where it may disturb or damage important landscape features or archeological resources.

Failing to survey the building site prior to the beginning of rehabilitation work which results in damage to, or destruction of, important landscape features or archeological resources.

Whenever possible, non-destructive techniques should be used to inventory and evaluate archeological resources to ensure their protection.

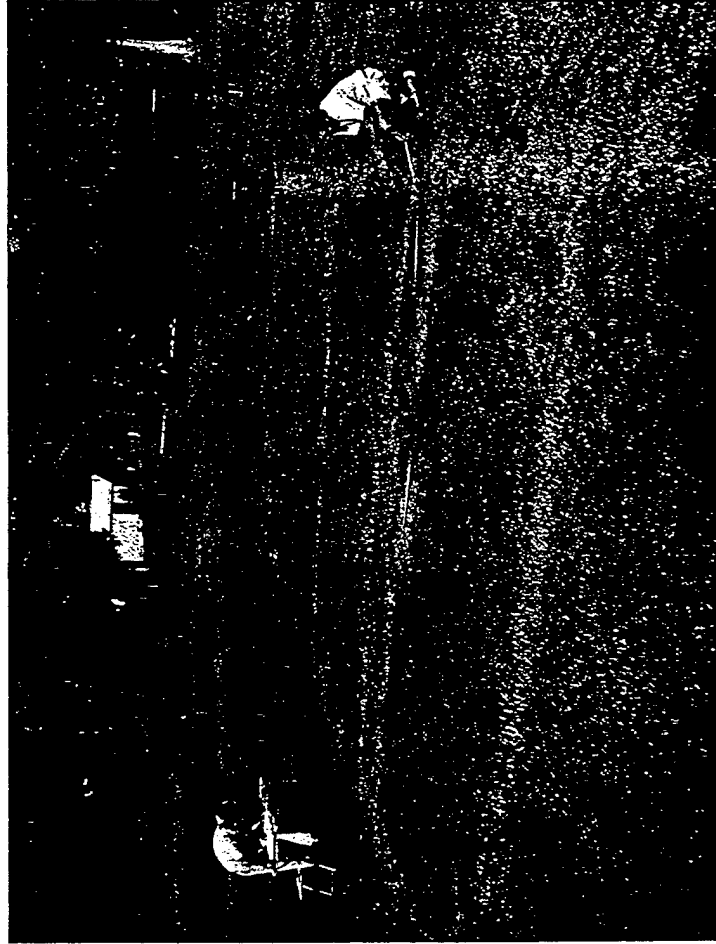

Recommended

Protect and maintain

Protecting, e.g., preserving in place important archaeological resources.

Planning and carrying out any necessary investigation using professional archeologists and modern archeological methods when preservation in place is not feasible.

Preserving important landscape features, including ongoing maintenance of historic plant material.

Protecting building and landscape features against arson and vandalism before rehabilitation work begins, i.e., erecting protective fencing and installing alarm systems that are keyed into local protection agencies.

Not Recommended

Leaving known archeological material unprotected so that it is damaged during rehabilitation work.

Permitting unqualified personnel to perform data recovery on archeological resources so that improper methodology results in the loss of important archeological material.

Allowing important landscape features to be lost or damaged due to a lack of maintenance.

Permitting the property to remain unprotected so that the building and landscape features or archeological resources are damaged or destroyed.

Removing or destroying features from the building or site such as wood siding, iron fencing, masonry balustrades, or plant material.

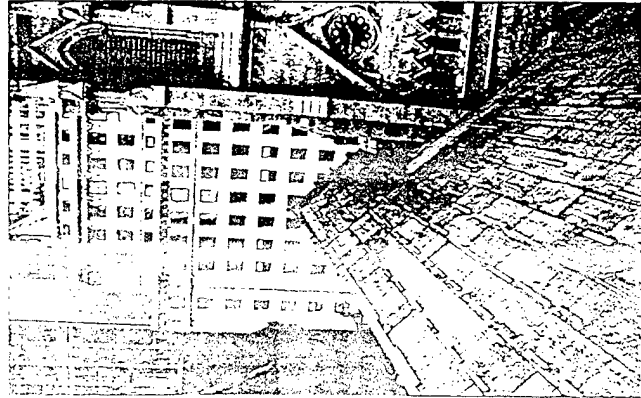

▲ The roof and stained glass windows of this historic church have been appropriately covered with plywood as a protective measure during construction of a new building on an adjacent lot.

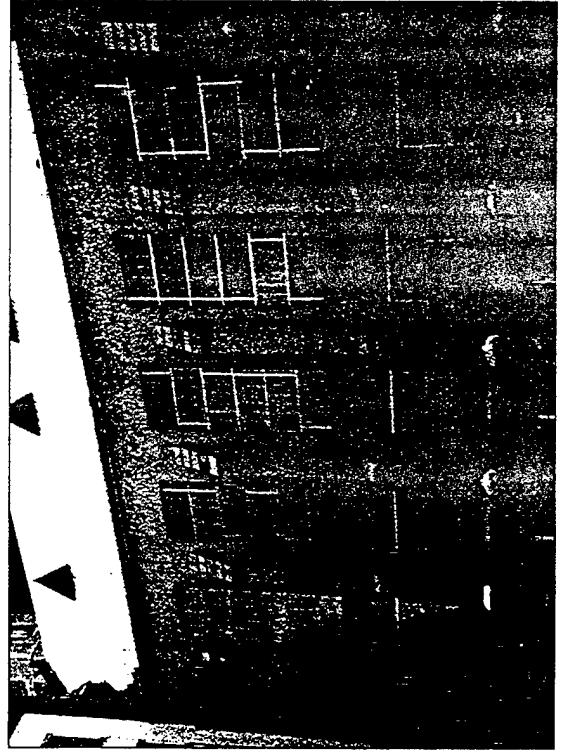

Recommended

Providing continued protection of masonry, wood, and architectural metals which comprise the building and site features through appropriate cleaning, rust removal, limited paint removal, and re-application of protective coating systems.

Evaluating the overall condition of materials and features to determine whether more than protection and maintenance are required, that is, if repairs to building and site features will be necessary.

Repair

Repairing features of the building and site by reinforcing historic materials.

Not Recommended

Failing to provide adequate protection of materials on a cyclical basis so that deterioration of building and site features results.

Failing to undertake adequate measures to assure the protection of building and site features.

Replacing an entire feature of the building or site such as a fence, walkway, or driveway when repair of materials and limited compatible replacement of deteriorated or missing parts are appropriate.

Using a substitute material for the replacement part that does not convey the visual appearance of the surviving parts of the building or site feature or that is physically or chemically incompatible.

Park-like settings surrounding many historic mansions are important in defining their historic character. However, the relationship between building and site was destroyed by an inappropriate rehabilitation when this house was converted into offices, and the formally landscaped grounds in front of the house were bulldozed to provide a parking lot.

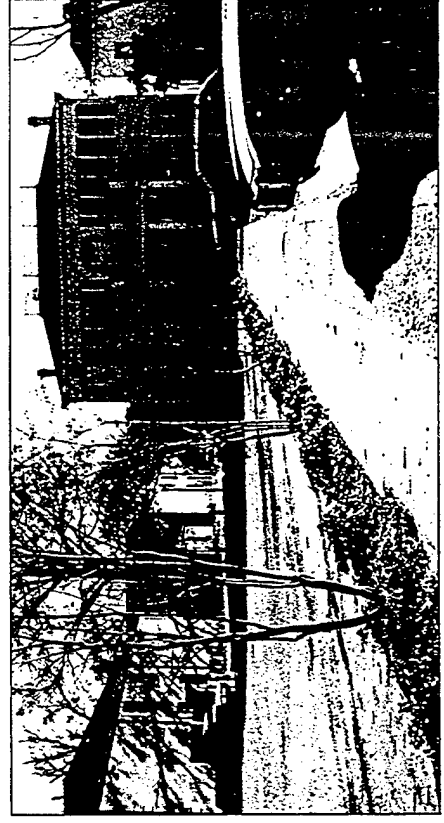

Recommended

Replace

Replacing in kind an entire feature of the building or site that is too deteriorated to repair if the overall form and detailing are still evident. Physical evidence from the deteriorated feature should be used as a model to guide the new work. This could include an entrance or porch, walkway, or fountain. If using the same kind of material is not technically or economically feasible, then a compatible substitute material may be considered.

Replacing deteriorated or damaged landscape features in kind.

Not Recommended

Removing a feature of the building or site that is unrepairable and not replacing it; or replacing it with a new feature that does not convey the same visual appearance.

Adding conjectural landscape features to the site such as period reproduction lamps, fences, fountains, or vegetation that is historically inappropriate, thus creating a false sense of historic development.

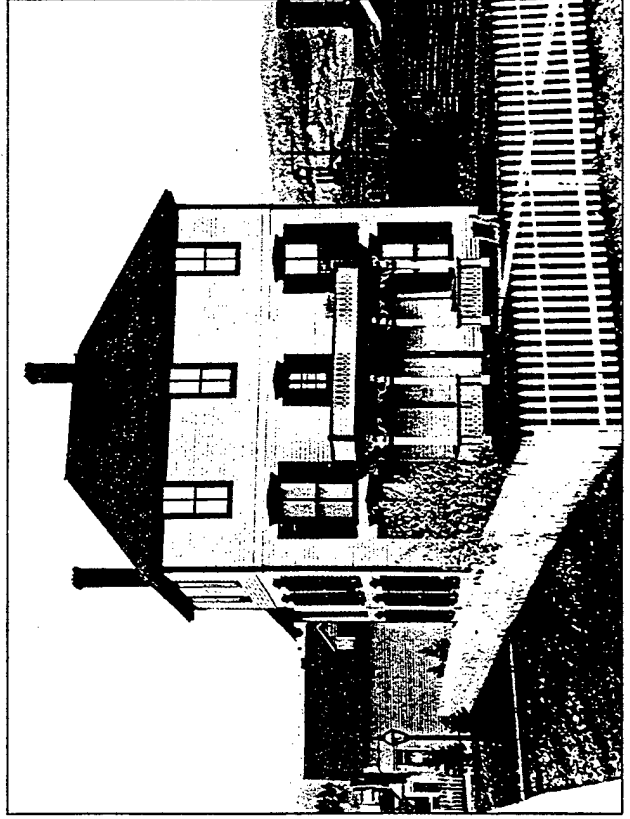

Photo: Library, The State Historical Society of Colorado

This wood picket fence is as important to the site as the shutters, porch detailing, and clapboards are to the house. As such, the fence was carefully repaired and painted as part of an overall project to preserve the historic residence.

The following work is highlighted to indicate that it represents the particularly complex technical or design aspects of rehabilitation project work and should only be considered after the preservation concerns listed above have been addressed.

Recommended

Design for Missing Historic Features

Designing and constructing a new feature of a building or site when the historic feature is completely missing, such as an outbuilding, terrace or driveway. It may be based on historical, pictorial, and physical documentation; or be a new design that is compatible with the historic character of the building and site.

Not Recommended

Creating a false historical appearance because the replaced feature is based on insufficient historical, pictorial, and physical documentation.

Introducing a new building or site feature that is out of scale or of an otherwise inappropriate design.

Introducing a new landscape feature, including plant material, that is visually incompatible with the site, or that alters or destroys the historic site patterns or vistas.

Locating any new construction on the building where important landscape features will be damaged or destroyed, for example removing a lawn and walkway and installing a parking lot.

Placing parking facilities directly adjacent to historic buildings where automobiles may cause damage to the buildings or to important landscape features.

Introducing new construction onto the building site which is visually incompatible in terms of size, scale, design, materials, color, and texture; which destroys historic relationships on the site; or which damages or destroys important landscape features.

Removing a historic building in a complex of buildings; or removing a building feature, or a landscape feature which is important in defining the historic character of the site.

Alterations/Additions for the New Use

Designing new onsite parking, loading docks, or ramps when required by the new use so that they are as unobtrusive as possible and assure the preservation of the historic relationship between the building or buildings and the landscape.

Designing new exterior additions to historic buildings or adjacent new construction which is compatible with the historic character of the site and which preserves the historic relationship between the building or buildings and the landscape.

Removing nonsignificant buildings, additions, or site features which detract from the historic character of the site.

Setting

*District or
Neighborhood*

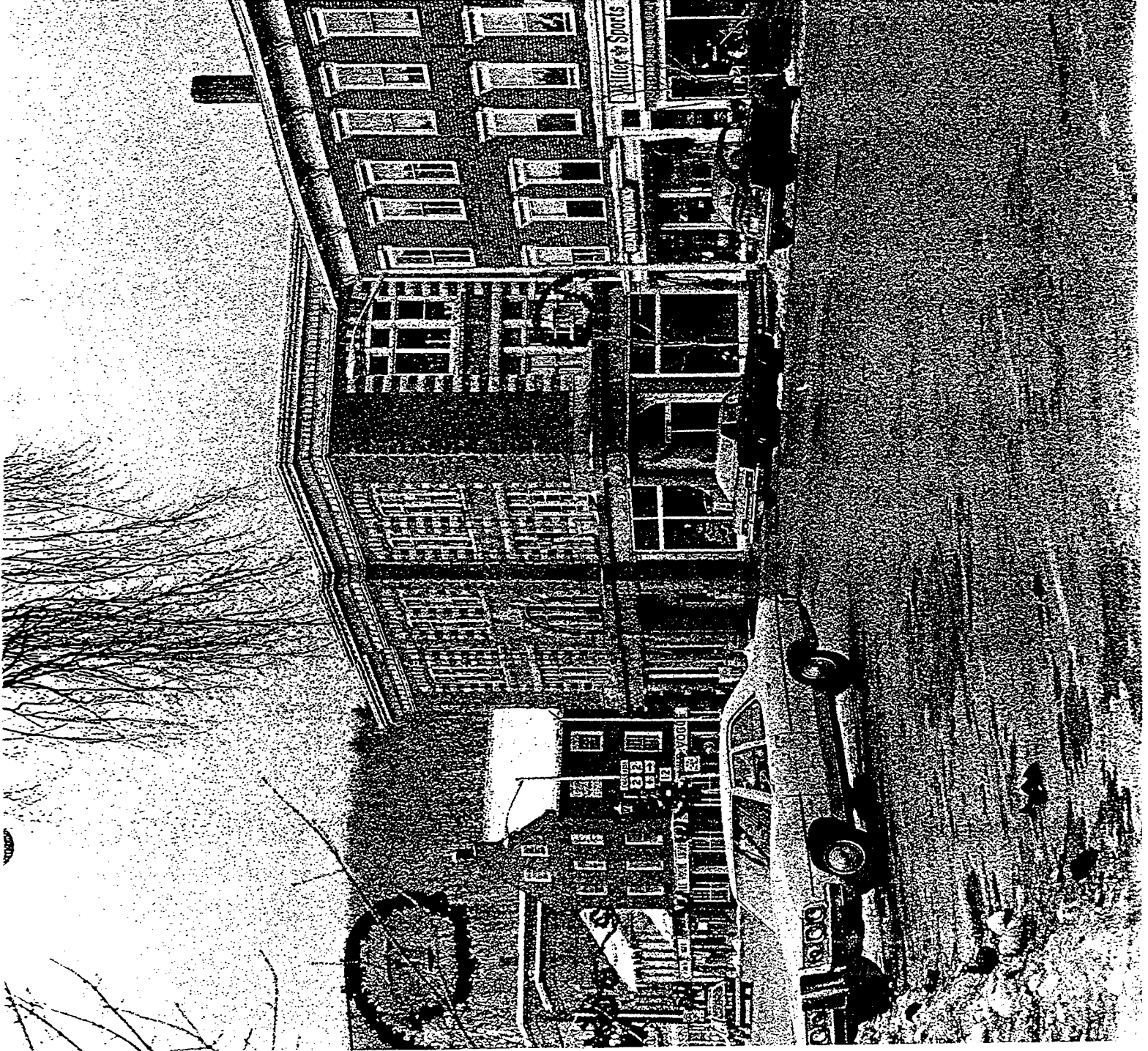

Setting

District or Neighborhood

The setting is the area or environment in which a historic property is found. It may be an urban or suburban neighborhood or a natural landscape in which a building has been constructed. The elements of setting, such as the relationship of buildings to each other, setbacks, fence patterns, views, driveways and walkways, and street trees together create the character of a district or neighborhood. In some instances, many individual building sites may form a neighborhood or setting. In rural environments, agricultural or natural landscapes may form the setting for an individual property.

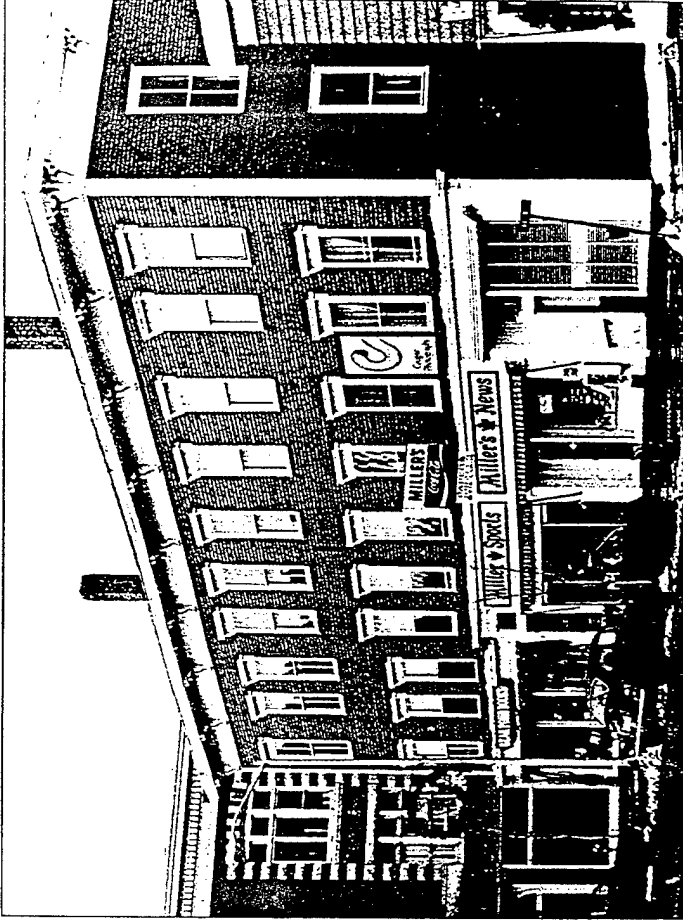

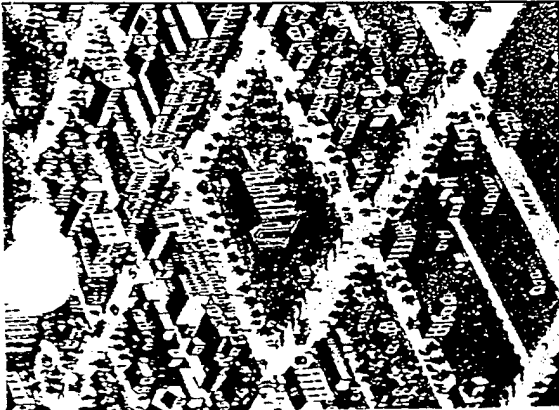

In an urban historic district, the alignment and width of roads, the relationship between buildings and yards, and the repetition of trees lining the streets help define its historic character.



The setting is an important aspect of a historic district. In a rural historic district, the natural topography and landscape features, agricultural field patterns, roads, and the organization of buildings and structures all contribute to its character.

Recommended

Identify, retain and preserve

Identifying, retaining, and preserving building and landscape features which are important in defining the historic character of the setting. Such features can include roads and streets, furnishings such as lights or benches, vegetation, gardens and yards, adjacent open space such as fields, parks, commons or woodlands, and important views or visual relationships.

Retaining the historic relationship between buildings and landscape features of the setting. For example, preserving the relationship between a town common and its adjacent historic houses, municipal buildings, historic roads, and landscape features.

Protect and maintain

Protecting and maintaining historic building materials and plant features through appropriate treatments such as cleaning, rust removal, limited paint removal, and reapplication of protective coating systems; and pruning and vegetation management.

Protecting buildings and landscape features against arson and vandalism before rehabilitation work begins by erecting protective fencing and installing alarm systems that are keyed into local protection agencies.

Not Recommended

Removing or radically changing those features of the setting which are important in defining the historic character.

Destroying the relationship between the buildings and landscape features within the setting by widening existing streets, changing landscape materials or constructing inappropriately located new streets or parking.

Removing or relocating historic buildings or landscape features, thus destroying their historic relationship within the setting.

Failing to provide adequate protection of materials on a cyclical basis which results in the deterioration of building and landscape features.

Permitting the building and setting to remain unprotected so that interior or exterior features are damaged.
Stripping or removing features from buildings or the setting such as wood siding, iron fencing, terra cotta balusters, or plant material.

Recommended

Evaluating the overall condition of the building and landscape features to determine whether more than protection and maintenance are required, that is, if repairs to features will be necessary.

Street furniture such as this historic clock helps define an urban district's character and thus should be retained in a rehabilitation.

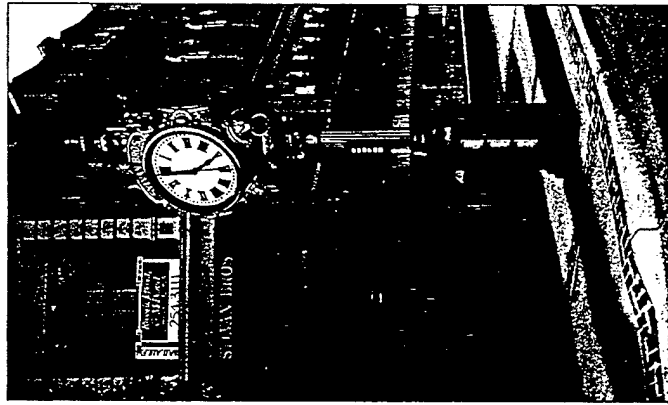
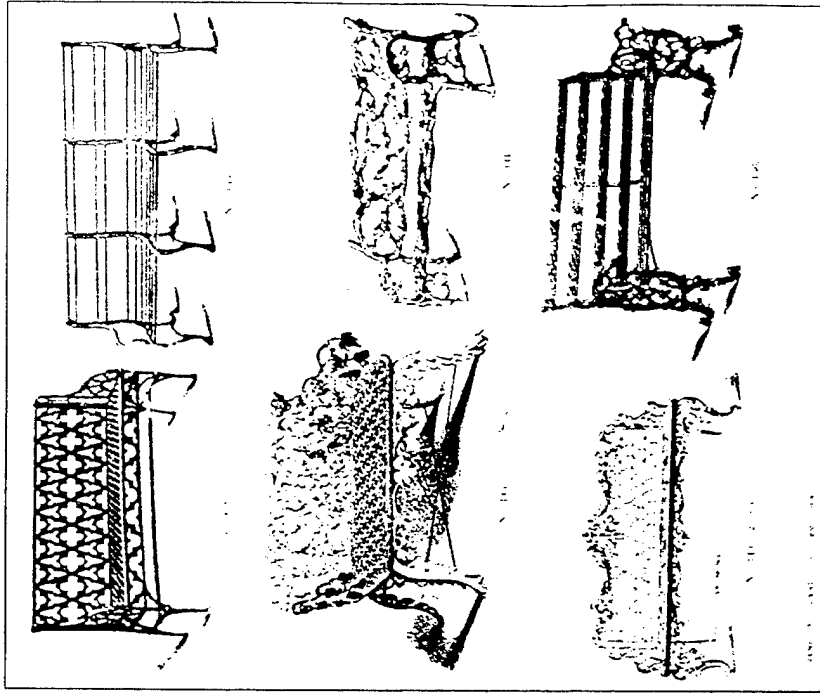

Photo: Jack E. Boucher, HABS.

Not Recommended

Failing to undertake adequate measures to assure the protection of building and landscape features.



Cast Iron Benches, illustrated in Catalogue of Ornamental Iron Works, James, Kirtland & Co., 1870. Benches can be important features both in defining an urban streetscape as well as a more rural landscape.

Repair

Repairing features of the building and landscape by reinforcing the historic materials. Repair will also generally include the replacement in kind—or with a compatible substitute material—of those extensively deteriorated or missing parts of features where there are surviving prototypes such as porch balustrades or paving materials.

Replacing an entire feature of the building or landscape when repair of materials and limited replacement of deteriorated or missing parts are appropriate.

Using a substitute material for the replacement part that does not convey the visual appearance of the surviving parts of the building or landscape, or that is physically, chemically, or ecologically incompatible.

This late-19th century residential historic district is characterized by brick row-houses with two-storied bays. A street-scapes visual continuity can be marred by an insensitive rehabilitation such as the one shown here. The original two-story brick bay of one of the houses was removed and replaced with a three-story bay that is incompatible in size, materials, and detailing.

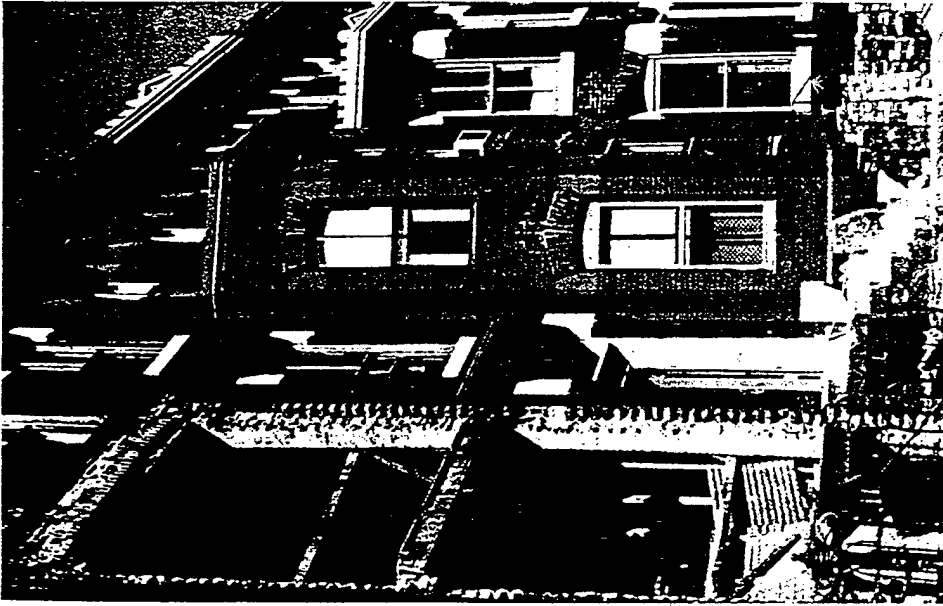

Recommended

Replace

Replacing in kind an entire feature of the building or landscape that is too deteriorated to repair — when the overall form and detailing are still evident — using the physical evidence as a model to guide the new work. If using the same kind of material is not technically or economically feasible, then a compatible substitute material may be considered.



Not Recommended

Removing a feature of the building or landscape that is unrepairable and not replacing it; or replacing it with a new feature that does not convey the same visual appearance.

The following work is highlighted because it represents the particularly complex technical or design aspects of rehabilitation projects and should only be considered after the preservation concerns above have been addressed.

Recommended

Design for Missing Historic Features

Designing and constructing a new feature of the building or landscape when the historic feature is completely missing, such as rowhouse steps, a porch, a streetlight, or terrace. It may be a restoration based on documentary or physical evidence; or be a new design that is compatible with the historic character of the setting.

Alterations/Additions for the New Use

Designing required new parking so that it is as unobtrusive as possible, thus minimizing the effect on the historic character of the setting. "Shared" parking should also be planned so that several businesses can utilize one parking area as opposed to introducing random, multiple lots.

Designing and constructing new additions to historic buildings when required by the new use. New work should be compatible with the historic character of the setting in terms of size, scale, design, material, color, and texture.

Removing nonsignificant buildings, additions or landscape features which detract from the historic character of the setting.

Not Recommended

Creating a false historical appearance because the replaced feature is based on insufficient documentary or physical evidence.

Introducing a new building or landscape feature that is out of scale or otherwise inappropriate to the setting's historic character, e.g., replacing picket fencing with chain link fencing.

Placing parking facilities directly adjacent to historic buildings which cause damage to historic landscape features, including removal of plant material, relocation of paths and walkways, or blocking of alleys.

Introducing new construction into historic districts that is visually incompatible or that destroys historic relationships within the setting.

Removing a historic building, building feature, or landscape feature that is important in defining the historic character of the setting.

Although the work in the following sections is quite often an important aspect of rehabilitation projects, it is usually *not* part of the overall process of preserving character-defining features (maintenance, repair, replacement); rather, such work is assessed for its potential negative impact on the building's historic character. For this reason, particular care must be taken not to obscure, radically change, damage, or destroy character-defining features in the process of rehabilitation work.

Energy Conservation

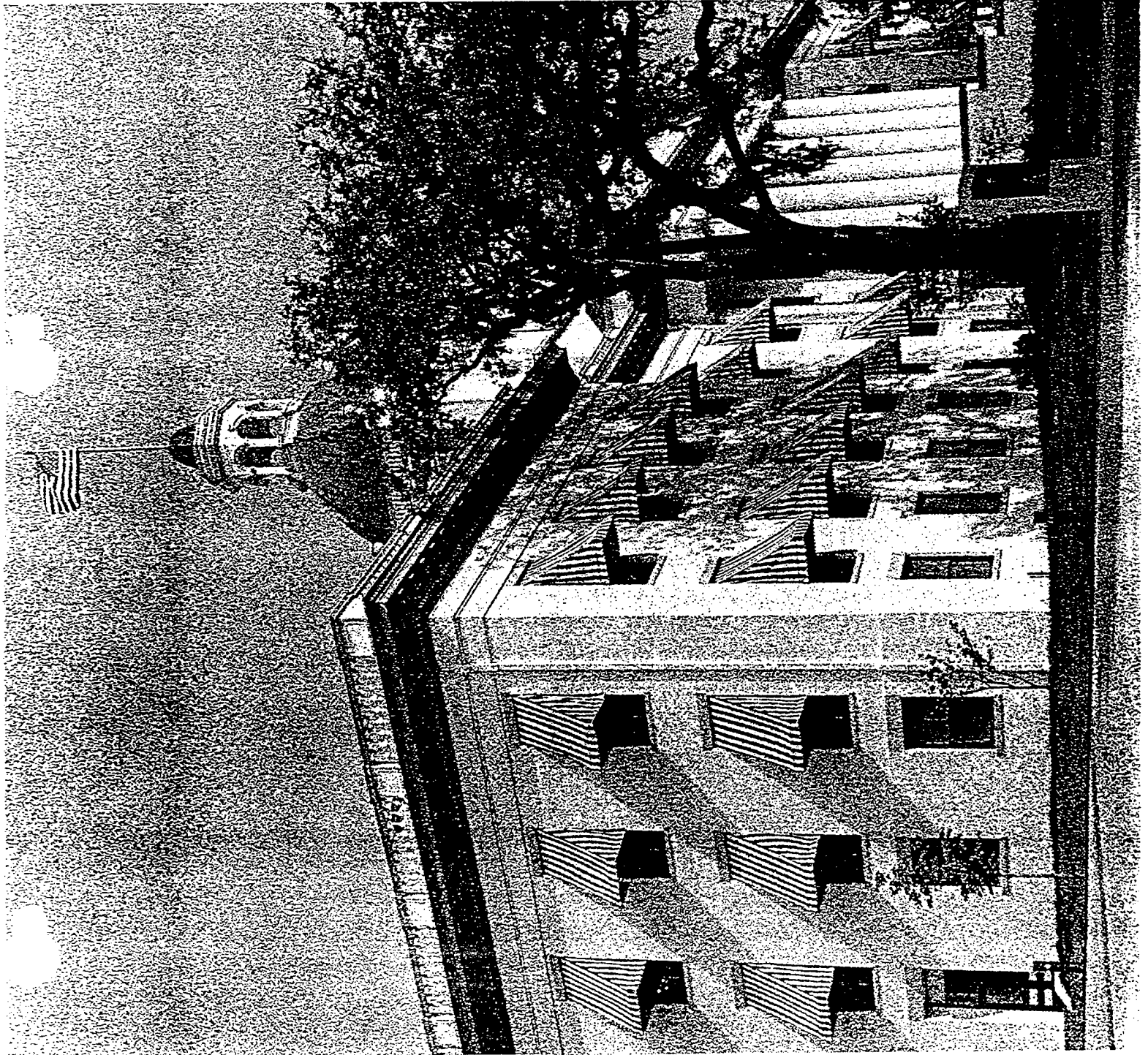

Energy Conservation

Some character-defining features of a historic building or site such as cupolas, shutters, transoms, skylights, sun rooms, porches, and plantings also play a secondary, energy-conserving role.

Therefore, prior to retrofitting historic buildings to make them more energy efficient, the first step should always be to identify and evaluate the existing historic features to assess their inherent energy-conserving potential. If it is determined that retrofitting measures are necessary, then such work needs to be carried out with particular care to insure that the building's historic character is preserved in the process of rehabilitation.

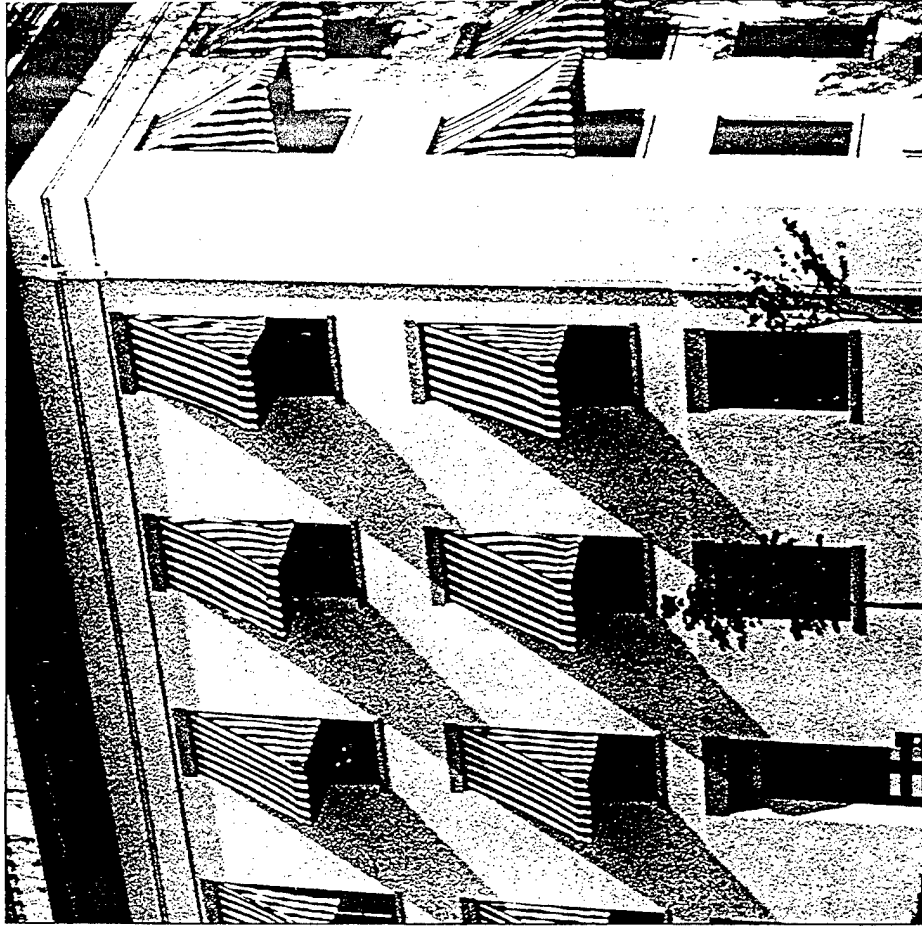

Recommended

District/Neighborhood

Maintaining those existing landscape features which moderate the effects of the climate on the setting such as deciduous trees, evergreen wind-blocks, and lakes or ponds.

Building Site

Retaining plant materials, trees, and landscape features, especially those which perform passive solar energy functions such as sun shading and wind breaks.

Installing freestanding solar collectors in a manner that preserves the historic property's character-defining features.

Designing attached solar collectors, including solar greenhouses, so that the character-defining features of the property are preserved.

Masonry/Wood/Architectural Metals

Installing thermal insulation in attics and in unheated cellars and crawlspaces to increase the efficiency of the existing mechanical systems.

Installing insulating material on the inside of masonry walls to increase energy efficiency where there is no character-defining interior molding around the window or other interior architectural detailing.

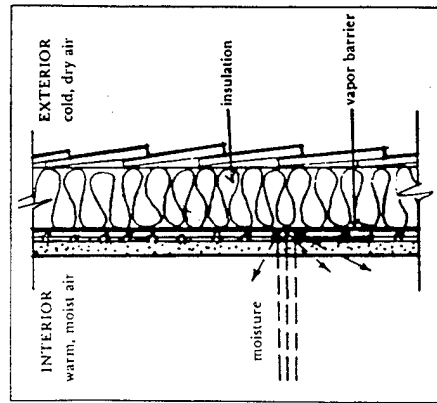

When installing insulation in the wall cavity of a historic wood-frame building, a vapor barrier must be placed facing in toward the heated side of the wall. The vapor barrier prevents moisture from passing from the warm interior to the cold exterior, thus keeping the insulation and adjacent building materials dry.

Not Recommended

Stripping the setting of landscape features and landforms so that the effects of the wind, rain, and the sun results in accelerated deterioration of historic materials.

Removing plant materials, trees, and landscape features, so that they no longer perform passive solar energy functions.

Installing freestanding solar collectors that obscure, damage, or destroy historic landscape or archeological features.

Locating solar collectors where they radically change the property's appearance; or damage or destroy character-defining features.

Applying thermal insulation with a high moisture content into wall cavities in an attempt to reduce energy consumption.

Resurfacing historic building materials with more energy efficient but incompatible materials, such as covering historic masonry with exterior insulation.

Recommended

Installing passive solar devices such as a glazed "trombe" wall on a rear or inconspicuous side of the historic building.

Roofs

Placing solar collectors on non-character-defining roofs or roofs of nonhistoric adjacent buildings.

Not Recommended

Installing passive solar devices such as an attached glazed "trombe" wall on primary or other highly visible elevations; or where historic material must be removed or obscured.

Placing solar collectors on roofs when such collectors change the historic roofline or obscure the relationship of the roof features such as dormers, skylights, and chimneys.

Removing historic shading devices rather than keeping them in an operable condition.

Replacing historic multi-paned sash with new thermal sash utilizing false muntins.

Installing interior storm windows that allow moisture to accumulate and damage the window.

Installing new exterior storm windows which are inappropriate in size or color.

Replacing windows or transoms with fixed thermal glazing or permitting windows and transoms to remain inoperable rather than utilizing them for their energy conserving potential.

Windows

Utilizing the inherent energy conserving features of a building by maintaining windows and louvered blinds in good operable condition for natural ventilation.

Improving thermal efficiency with weatherstripping, storm windows, caulking, interior shades, and if historically appropriate, blinds and awnings.

Installing interior storm windows with air-tight gaskets, ventilating holes, and/or removable clips to insure proper maintenance and to avoid condensation damage to historic windows.

Installing exterior storm windows which do not damage or obscure the windows and frames.

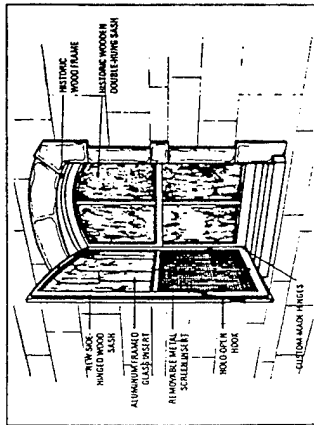

Historic residential window — appropriate storm window retrofit. The single casement, wooden storm window has two removable panels for screen and glass inserts. It is designed to minimize visual changes to the historic building.

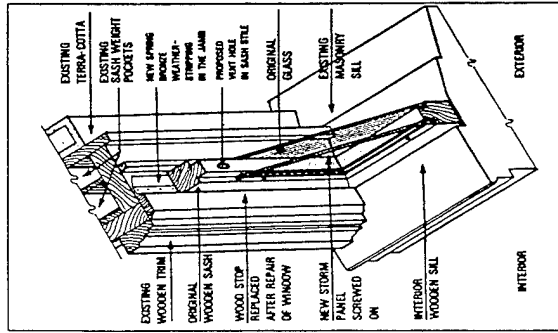

Historic commercial window — appropriate storm window retrofit. This cutaway view shows how the historic sash would receive a recessed storm panel through routing or cutting an inside rabbet.

Recommended

Considering the use of lightly tinted glazing on non-character-defining elevations if other energy retrofitting alternatives are not possible.

Entrances and Porches

Utilizing the inherent energy conserving features of a building by maintaining porches and double vestibule entrances in good condition so that they can retain heat or block the sun and provide natural ventilation.

Not Recommended

Using tinted or reflective glazing on character-defining or other conspicuous elevations.

Enclosing porches located on character-defining elevations to create passive solar collectors or airlock vestibules. Such enclosures can destroy the historic appearance of the building.



In hot climates, buildings were historically designed to minimize the heat gain from the summer sun. The wide roof overhangs, exterior porches, shutters, shade trees, and heavy masonry walls (painted white) are all energy saving characteristics.

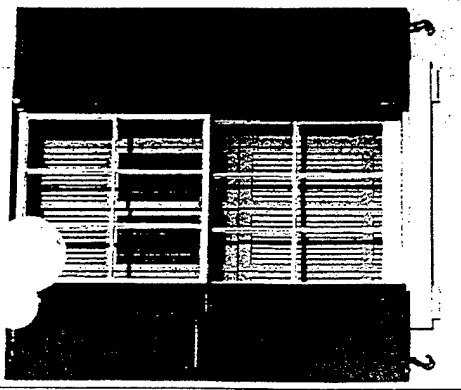

Shutters were used to minimize temperature extremes. If interior or exterior shutters are present, they should be retained, preserved, and used as they were historically.

Recommended

Interior Features

Retaining historic interior shutters and transoms for their inherent energy conserving features.

Not Recommended

Removing historic interior features which play a secondary energy conserving role.

New Additions to Historic Buildings

Placing new additions that have an energy conserving function such as a solar greenhouse on non-character-defining elevations.

Installing new additions such as multi-story solar greenhouse additions which obscure, damage, or destroy character-defining features.

Mechanical Systems

Improving energy efficiency of existing mechanical systems by installing insulation in attics and basements.

Replacing existing mechanical systems that could be repaired for continued use.

This decorative cast-iron vent serves a useful passive energy conservation function by allowing air to circulate at basement level.

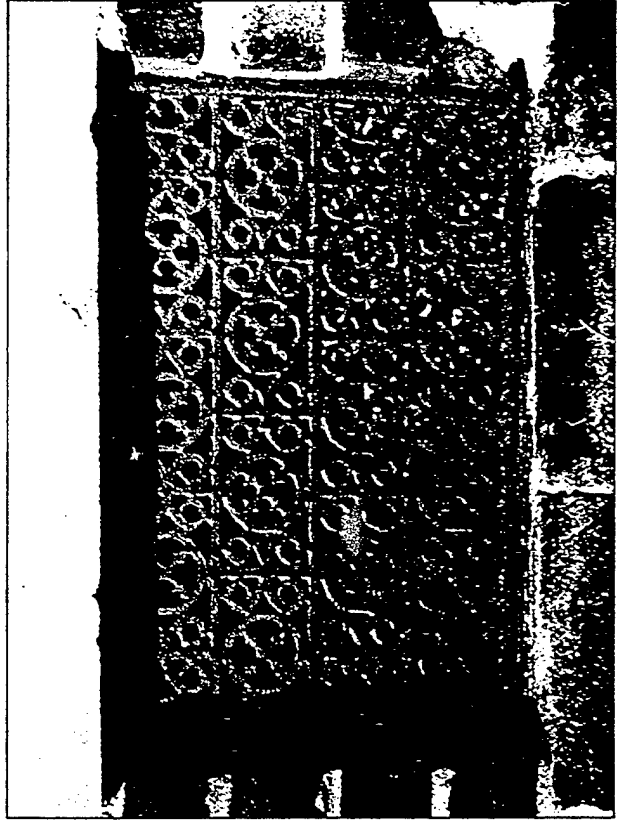

New Additions to Historic Buildings

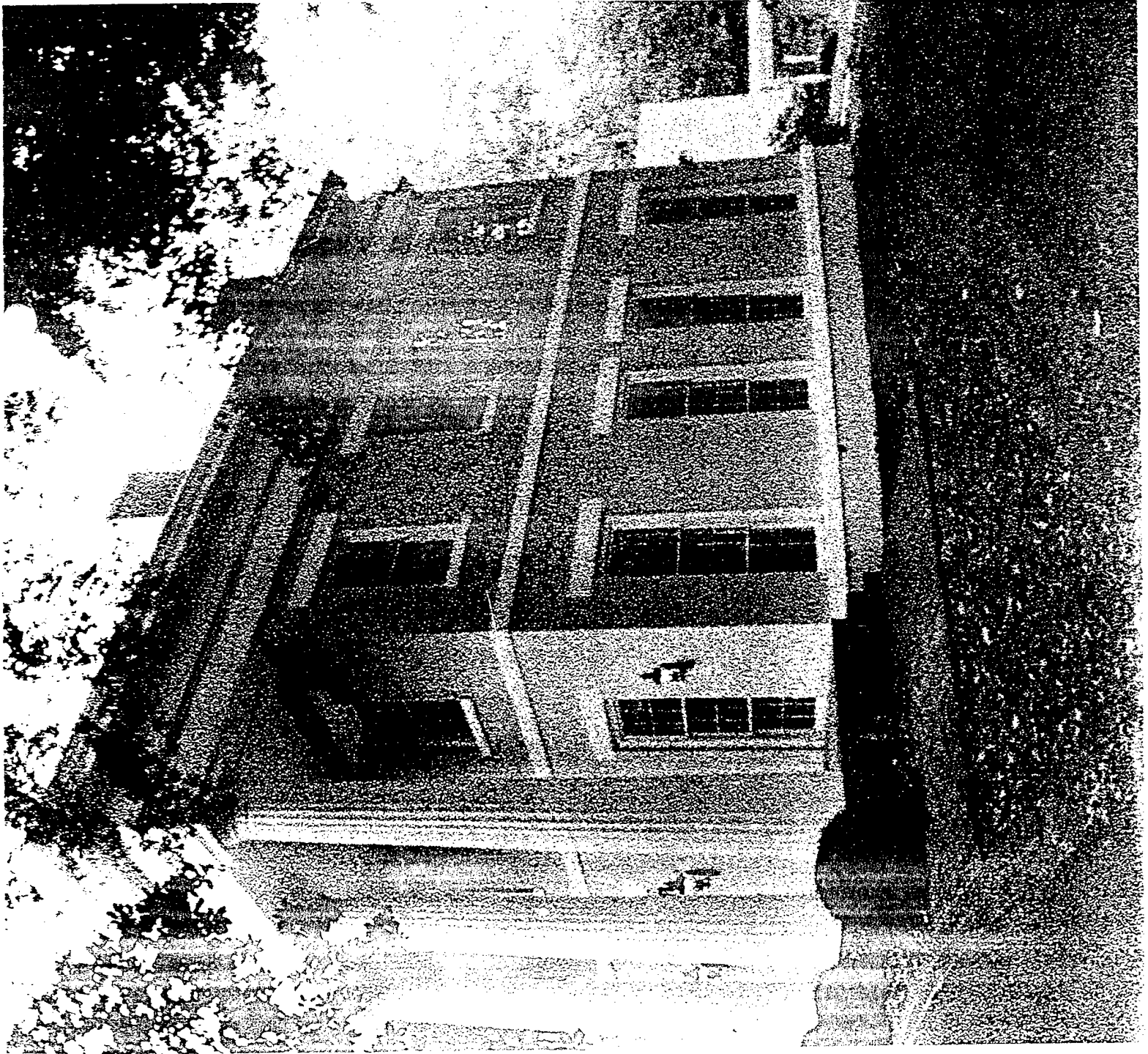

New Additions to Historic Buildings

An attached exterior addition to a historic building expands its "outer limits" to create a new profile. Because such expansion has the capability to radically change the historic appearance, an exterior addition should be considered only after it has been determined that the new use cannot be successfully met by altering non-character-defining interior spaces. If the new use cannot be met in this way, then an attached exterior addition is usually an acceptable alternative. New additions should be designed and constructed so that the character-defining features of the historic building are not radically changed, obscured, damaged, or destroyed in the process of rehabilitation. New design should always be clearly differentiated so that the addition does not appear to be part of the historic resource.

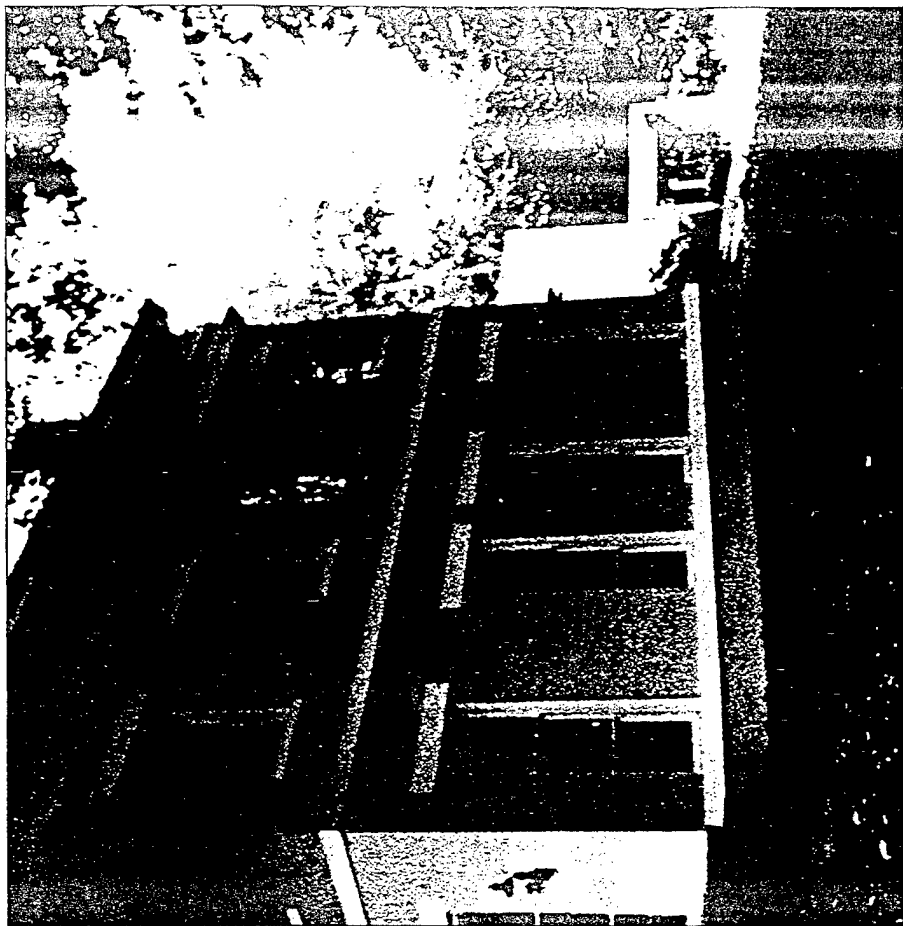

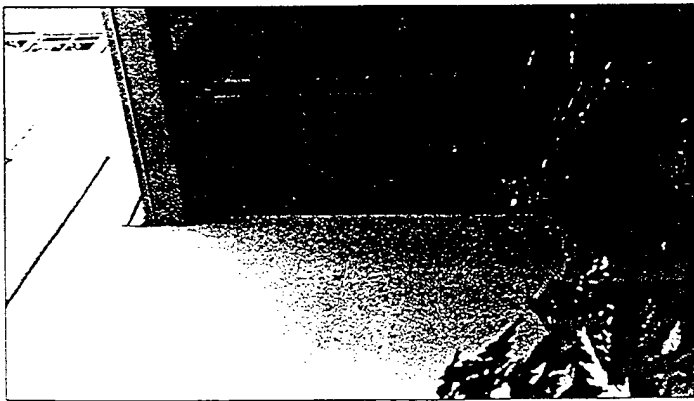

Recommended

Placing functions and services required for the new use in non-character-defining interior spaces rather than constructing a new addition.

Constructing a new addition so that there is the least possible loss of historic materials and so that character-defining features are not obscured, damaged, or destroyed.

Locating the attached exterior addition at the rear or on an inconspicuous side of a historic building; and limiting its size and scale in relationship to the historic building.

An 1847 residence was successfully converted into a bank, with the construction of a low-scale addition. The drawing shows how the three-unit addition has been stepped down the hill, each unit set further back from the historic structure as it extends horizontally. As a result, the new addition is only partially visible from the historic "approach." The small connector was sensitively designed to minimize loss of historic building materials.

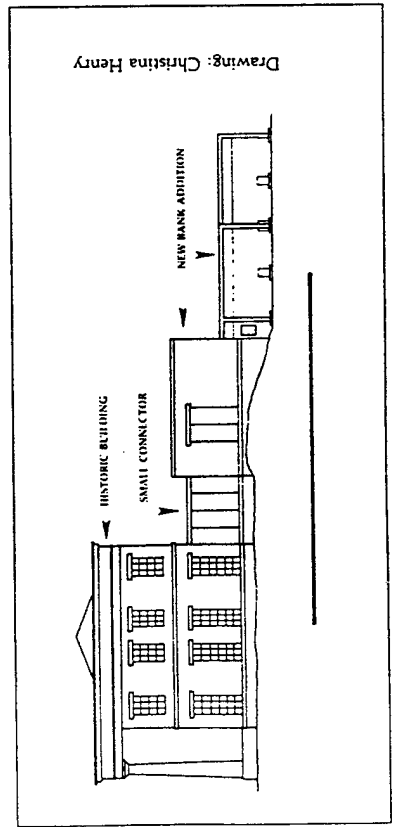

Not Recommended

Expanding the size of the historic building by constructing a new addition when the new use could be met by altering non-character-defining interior spaces.

Attaching a new addition so that the character-defining features of the historic building are obscured, damaged, or destroyed.

Designing a new addition so that its size and scale in relation to the historic building are out of proportion, thus diminishing the historic character.

Duplicating the exact form, material, style, and detailing of the historic building in the new addition so that the new work appears to be part of the historic building.

Imitating a historic style or period of architecture in new additions, especially for contemporary uses such as drive-in banks or garages.

A new 10-story wing added to the back of a historic library constitutes major expansion, yet is compatible because it reads as a subsidiary unit to the much larger historic building.

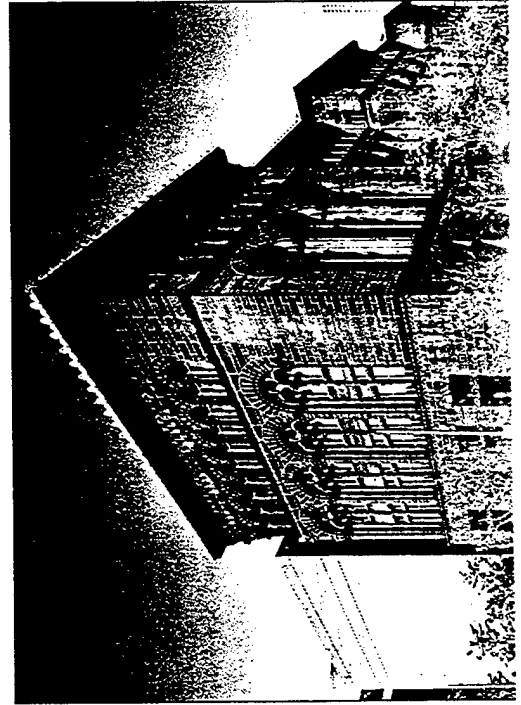

Left: This top addition has substantially altered the historic profile and proportions of a three-story row house; more important, it has interrupted the uniform roof height of the block. The greenhouse is also a jarring element in an otherwise intact 19th century streetscape. Below: A sizeable employee lounge was added atop this four-story historic commercial building. Because the rooftop addition has been set back from both the front and side roof edges against a party wall, the historic character of the building and the district have been preserved.



Recommended

Considering the attached exterior addition both in terms of the new use and the appearance of other buildings in the historic district or neighborhood. Design for the new work may be contemporary or may reference design motifs from the historic building. In either case, it should always be clearly differentiated from the historic building and be compatible in terms of mass, materials, relationship of solids to voids, and color.

Not Recommended

Designing and constructing new additions that result in the diminution or loss of the historic character of the resource, including its design, materials, workmanship, location, or setting.

Using the same wall plane, roof line, cornice height, materials, siding lap or window type to make additions appear to be a part of the historic building.

Recommended



The historic residence is on the right. By copying the decorative gable and three-part window in the new addition, the old and new portions are virtually indistinguishable. This approach violates the Standards for Rehabilitation.

Placing new additions such as balconies and greenhouses on non-character-defining elevations and limiting the size and scale in relationship to the historic building.

Designing additional stories, when required for the new use, that are set back from the wall plane and are as inconspicuous as possible when viewed from the street.

Not Recommended

Designing new additions such as multi-story greenhouse additions that obscure, damage, or destroy character-defining features of the historic building.

Constructing additional stories so that the historic appearance of the building is radically changed.

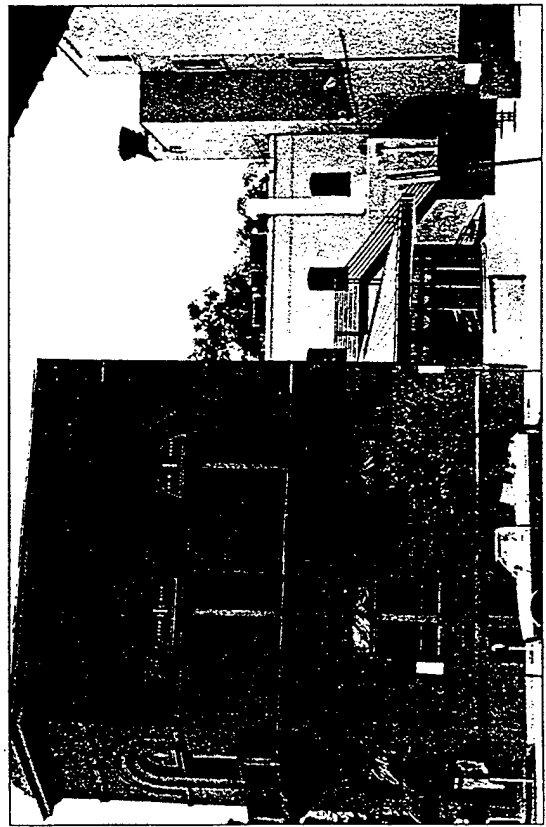

In rehabilitating a historic bank for a new use, a small restaurant addition was built on the rear. The new addition is compatible with the historic building primarily because of its scale and location.



Two small Victorian cottages, above, were connected to provide additional floor space in a commercial rehabilitation. The inappropriate infill connector, below, is on the same plane as the historic facades, essentially making the two cottages appear as one building. If the new infill had been substantially set back from the facade, the distinct form of each cottage would have been retained.

Accessibility Considerations

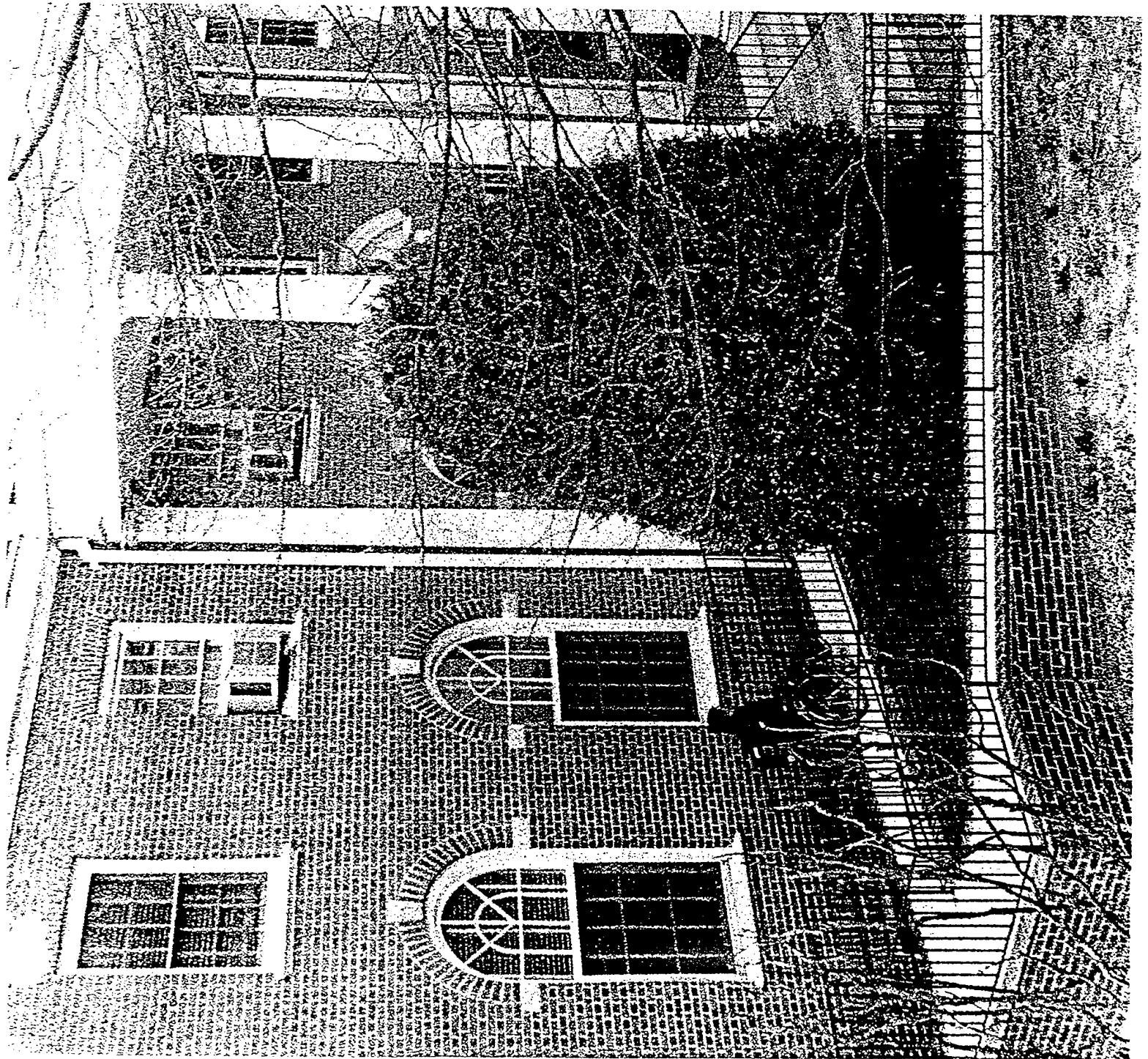

Accessibility Considerations

It is often necessary to make modifications to a historic property so that it can comply with current accessibility code requirements. Accessibility to certain historic buildings and sites is required by three specific federal laws: the Architectural Barriers Act of 1968, Section 504 of the Rehabilitation Act of 1973, and the Americans with Disabilities Act of 1990. Federal rules, regulations, and standards have been developed which provide guidance on how to accomplish access in historic areas. The question is not *if* access should be provided; the question is *how* to provide

it to meet both accessibility and historic preservation requirements. Thus, work must be carefully planned and undertaken so that it does not result in a loss of character-defining spaces, features, and finishes. The goal is to provide the highest level of access with the lowest level of impact.

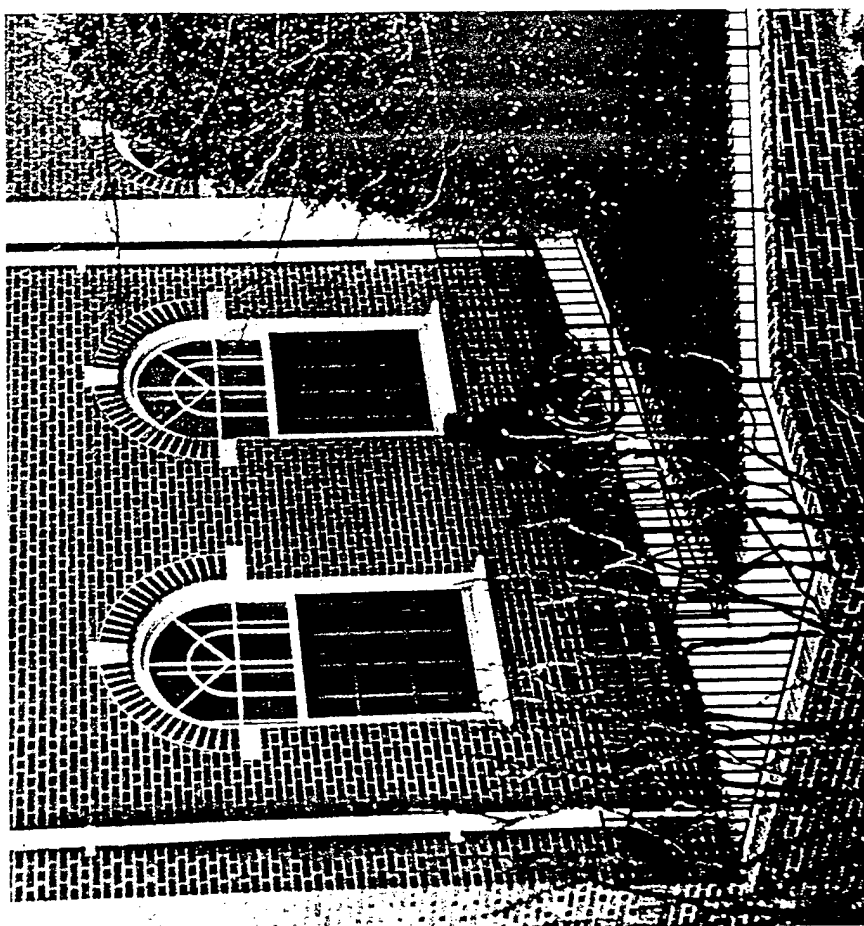

Recommended

Identifying the historic building's character defining spaces, features, and finishes so that accessibility code-required work will not result in their damage or loss.

Not Recommended

Undertaking code-required alterations before identifying those spaces, features or finishes which are character-defining and must therefore be preserved.

Complying with barrier-free access requirements, in such a manner that character-defining spaces, features, and finishes are preserved.

Altering, damaging, or destroying character-defining features in attempting to comply with accessibility requirements.

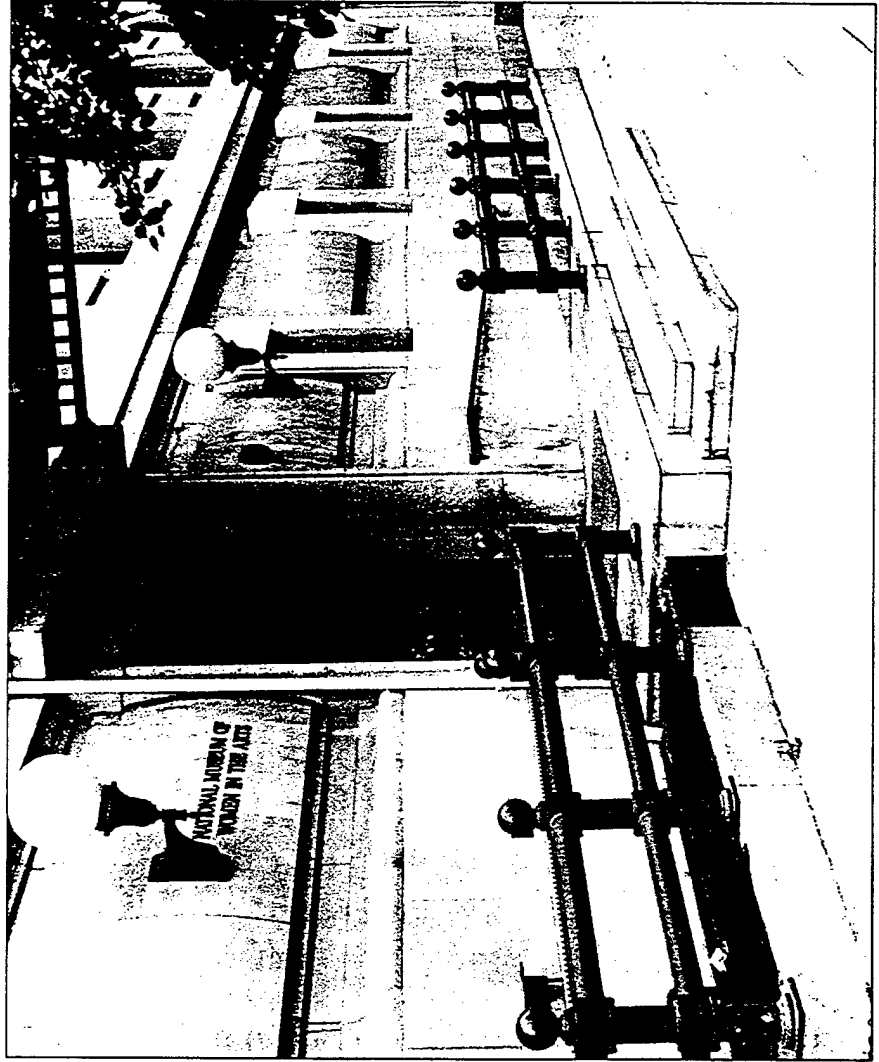

The historic cast iron railing was preserved when a permanent ramp was designed for this museum's main entrance.

Access to a historic site has been improved to include designated parking areas, properly graded ramps and walkways around the site, and access within the building to all services.



Photo: Cuyahoga Valley National Recreation Area, NPS

Recommended

Working with local disability groups, access specialists, and historic preservation specialists to determine the most appropriate solution to access problems.

Providing barrier-free access that promotes independence for the disabled person to the highest degree practicable, while preserving significant historic features.

Designing new or additional means of access that are compatible with the historic property and its setting.

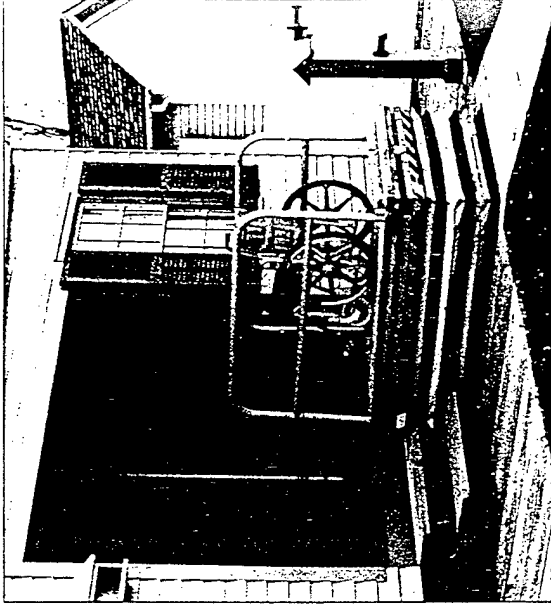

An air-condition-type platform lift that retracts to ground level when not in use has been installed to make this historic house accessible.

Not Recommended

Making changes to buildings without first seeking expert advice from access specialists and historic preservationists, to determine solutions.

Providing access modifications that do not provide a reasonable balance between independent, safe access and preservation of historic features.

Designing new or additional means of access without considering the impact on the historic property and its setting.

A relatively simple way to increase accessibility inside a historic building may be to add bevels to the sides of a threshold.

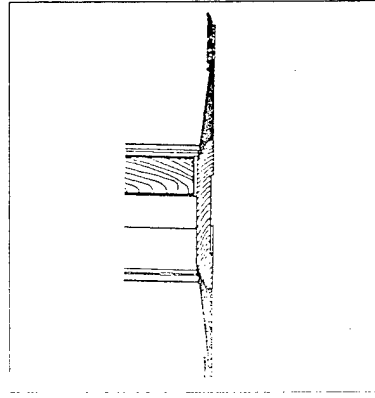

Health and Safety Considerations

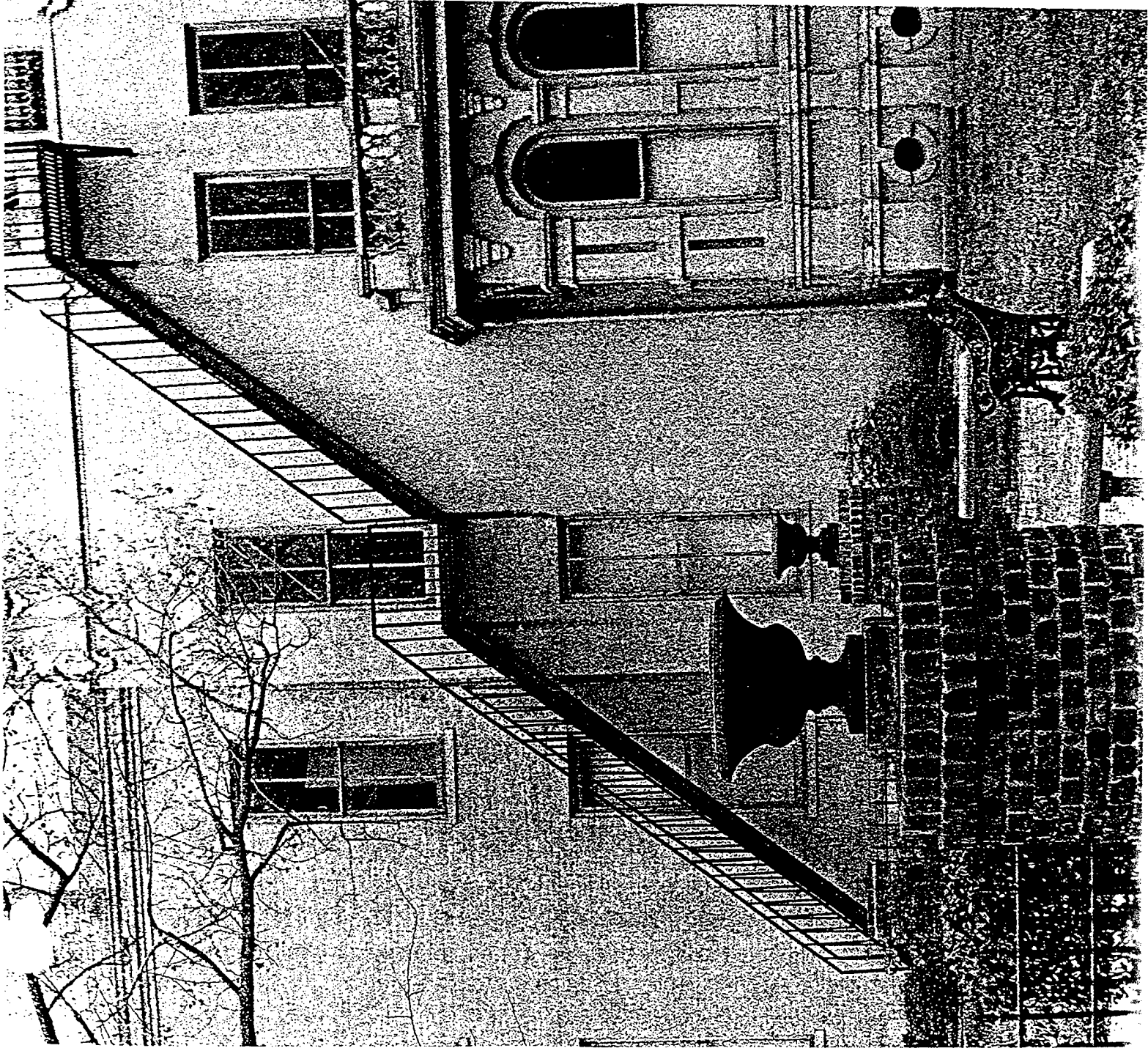

Health and Safety Considerations

In undertaking rehabilitation work on historic buildings, it is necessary to consider the impact that meeting current health and safety codes (public health, occupational health, life safety, fire safety, electrical, structural and building codes) will have on character-defining spaces, features, and finishes. Special coordination with the responsible code officials at the state, county or municipal level may be required. Securing required building permits and occupancy licenses is best accomplished early in rehabilitation planning.

In the area of occupational health, research on older, more commonly used building materials (insulation, floor and wall coverings and lead paints) indicates that the presence of toxic substances in them is potentially hazardous to building occupants. Following careful investigation and analysis, some form of abatement may be required such as encapsulation, or partial or total removal. All workers involved in the encapsulation, repair, or removal of known toxic materials should be adequately trained and

should wear proper personal protective equipment. Finally, preventive and routine maintenance programs for historic structures known to contain such materials should also be developed to include proper warnings and precautions.

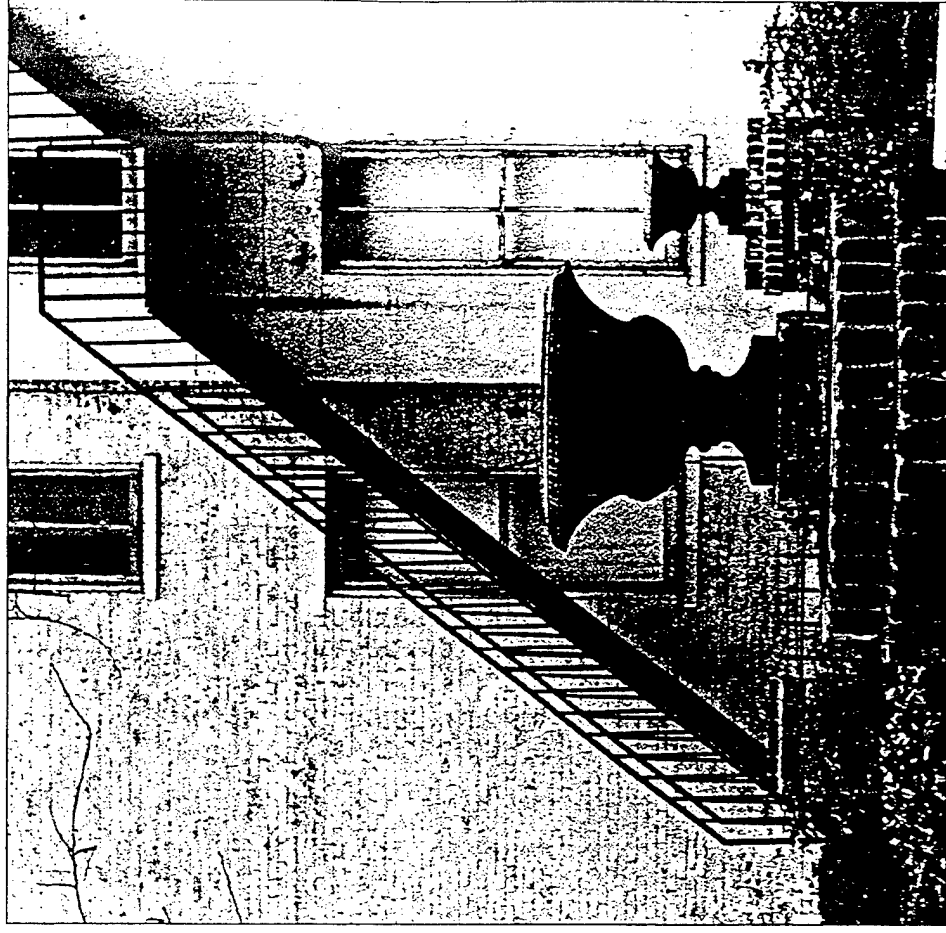

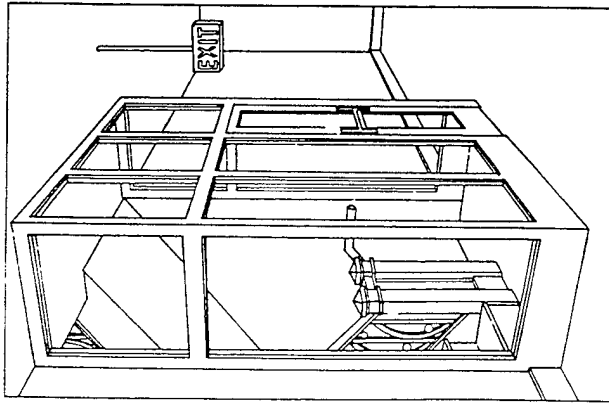

Existing decorative staircases in historic buildings may meet safety requirements if enclosed with safety glass. This enclosure preserves the stairs while providing a secure means of egress.

Recommended

Identifying the historic building's character-defining spaces, features, and finishes so that code-required work will not result in their damage or loss.

Complying with health and safety codes, including seismic code requirements, in such a manner that character-defining spaces, features, and finishes are preserved.

Removing toxic building materials only after thorough testing has been conducted and only after less invasive abatement methods have been shown to be inadequate.

Providing workers with appropriate personal protective equipment for hazards found in the worksite.

Working with local code officials to investigate systems, methods, or devices of equivalent or superior effectiveness and safety to those prescribed by code so that unnecessary alterations can be avoided.

Upgrading historic stairways and elevators to meet health and safety codes in a manner that assures their preservation, i.e., so that they are not damaged or obscured.

Not Recommended

Undertaking code-required alterations to a building or site before identifying those spaces, features, or finishes which are character-defining and must therefore be preserved.

Altering, damaging, or destroying character-defining spaces, features, and finishes while making modifications to a building or site to comply with safety codes.

Destroying historic interior features and finishes without careful testing and without considering less invasive abatement methods.

Removing unhealthful building materials without regard to personal and environmental safety.

Making changes to historic buildings without first exploring equivalent health and safety systems, methods, or devices that may be less damaging to historic spaces, features, and finishes.

Damaging or obscuring historic stairways and elevators or altering adjacent spaces in the process of doing work to meet code requirements.

A sprinkler has been sensitively installed in this highly ornamental plaster ceiling during the building's rehabilitation. Sprinkler heads have been unobtrusively located in the center of the decorative plaster relief.

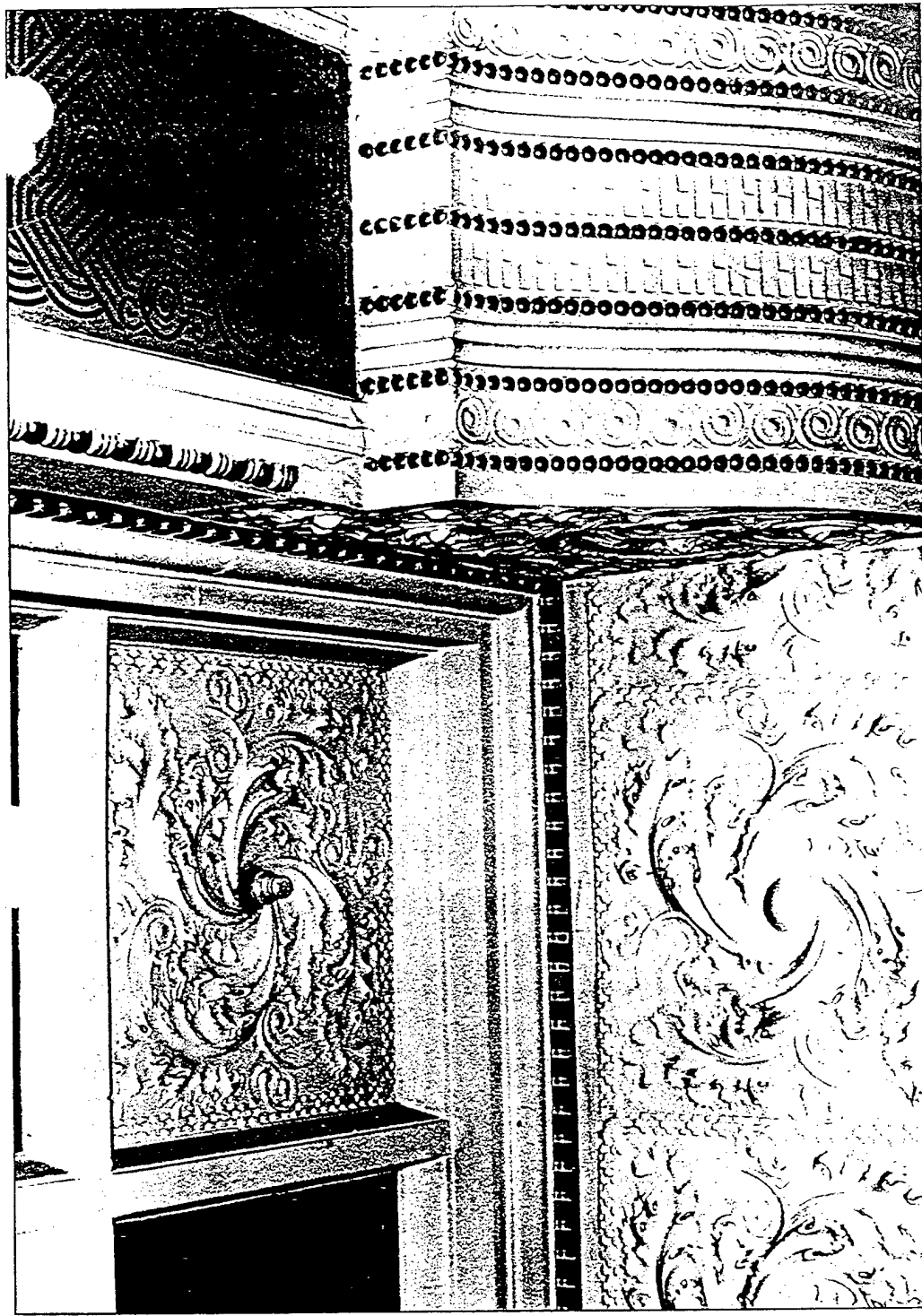

Recommended

Installing sensitively designed fire suppression systems, such as sprinkler systems that result in retention of historic features and finishes.

Applying fire-retardant coatings, such as intumescent paints, which expand during fire to add thermal protection to steel.

Not Recommended

Covering character-defining wood features with fire-resistant sheathing which results in altering their visual appearance.

Using fire-retardant coatings if they damage or obscure character-defining features.

Recommended

Adding a new stairway or elevator to meet health and safety codes in a manner that preserves adjacent character-defining features and spaces.

Placing a code-required stairway or elevator that cannot be accommodated within the historic building in a new exterior addition. Such an addition should be on an inconspicuous elevation.

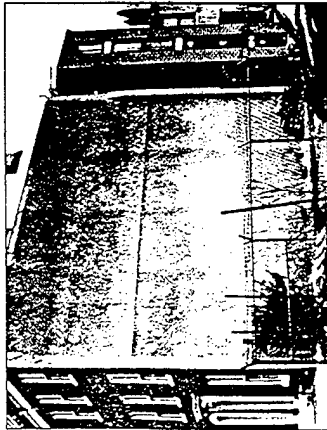

In order to comply with safety codes, it may be necessary to add an exterior fire stair to a historic building as part of a rehabilitation project. The brick stairtower shown on the top is compatible in materials and scale, and inconspicuously attached to the rear elevation of the historic rowhouse. The example on the bottom shows a large-scale concrete and glass stairtower that is incompatible in materials and scale, located as it is on a highly visible elevation of the historic brick building.

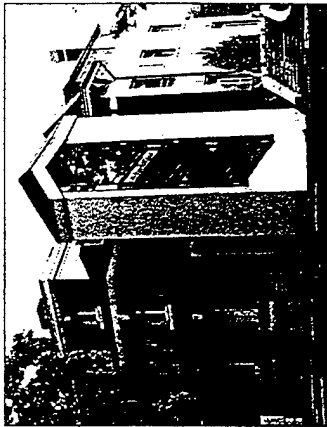

In buildings such as this historic courthouse, where old lead-based paint is essentially intact and covered with a lead-free topcoat, removing the historic paint because of potential toxicity may not be necessary. Historic paint can provide valuable documentation about the evolution of a building and should be retained, whenever possible.

Not Recommended

Radically changing, damaging, or destroying character-defining spaces, features, or finishes when adding a new code-required stairway or elevator.

Constructing a new addition to accommodate code-required stairs and elevators on character-defining elevations highly visible from the street; or where it obscures, damages, or destroys character-defining features.

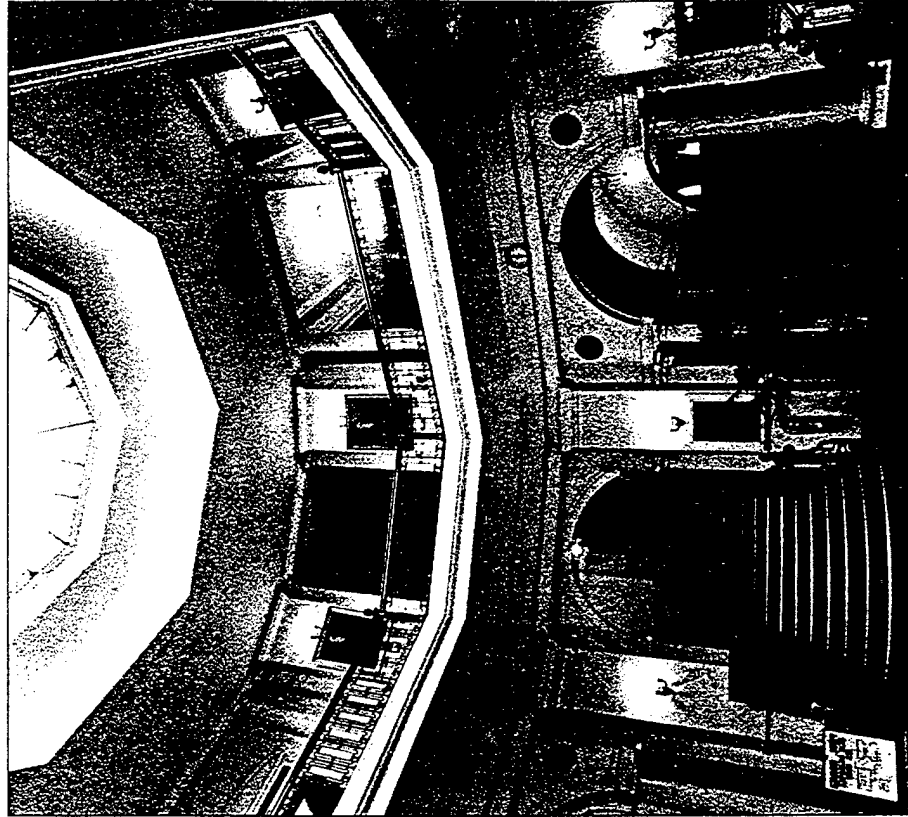

Technical
Guidance
Publications

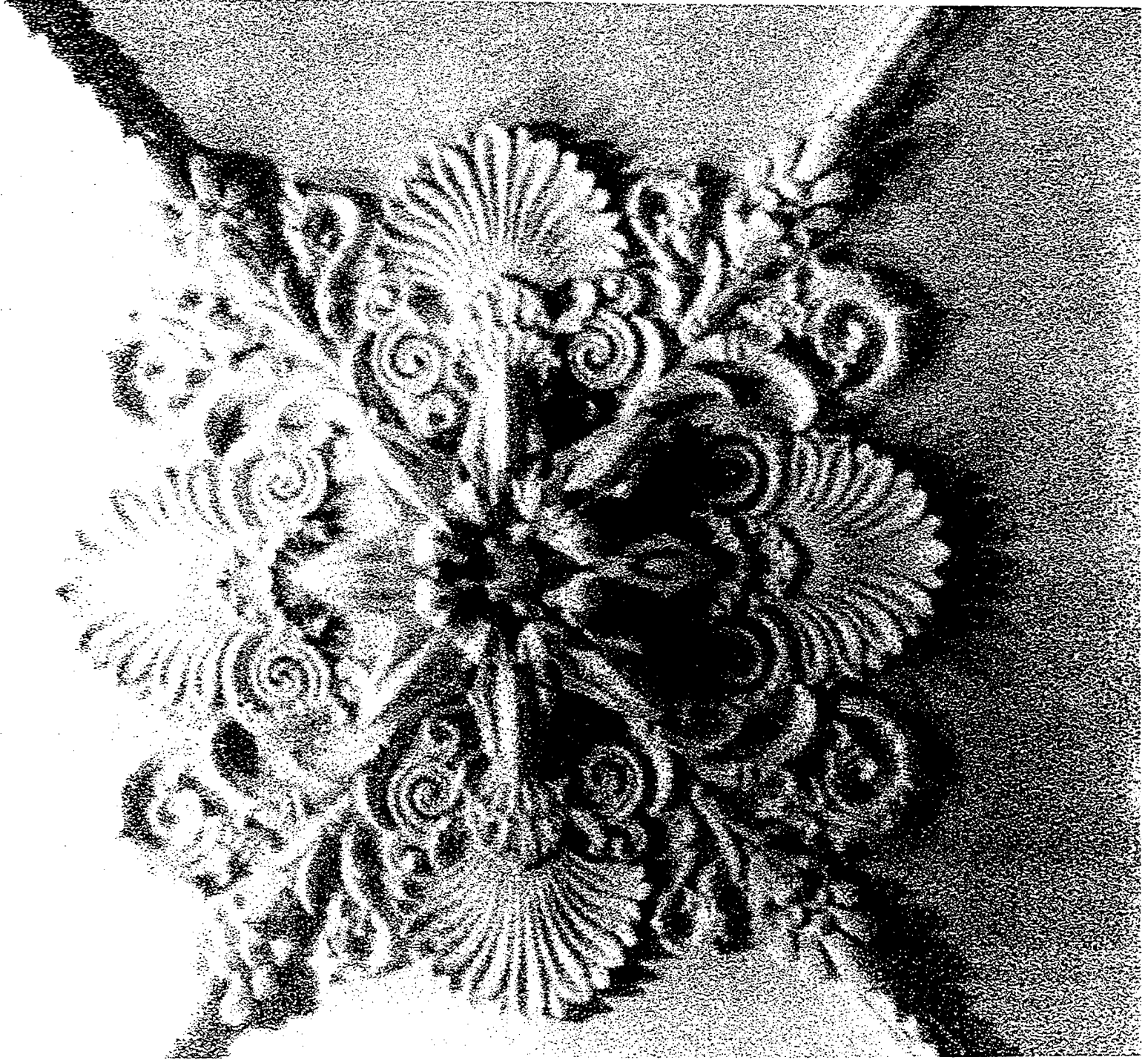

Technical Guidance Publications

The Preservation Assistance Division, National Park Service, conducts a variety of activities to guide Federal agencies, States, and the general public in historic preservation project work. In addition to establishing standards and guidelines, the Service develops, publishes, and distributes technical information on appropriate preservation treatments including Preservation Briefs, Preservation Case Studies, and Preservation Tech Notes.

These books, handbooks, technical leaflets and data bases are available through sales from several outlets, including the U.S. Government Printing

Office, National Technical Information Service, American Association for State and Local History, and Historic Preservation Education Foundation. A Catalog of Historic Preservation Publications with stock numbers, prices, and ordering information may be obtained by writing: National Park Service, Preservation Assistance Division, P.O. Box 37127, Washington, D.C. 20013-7127.

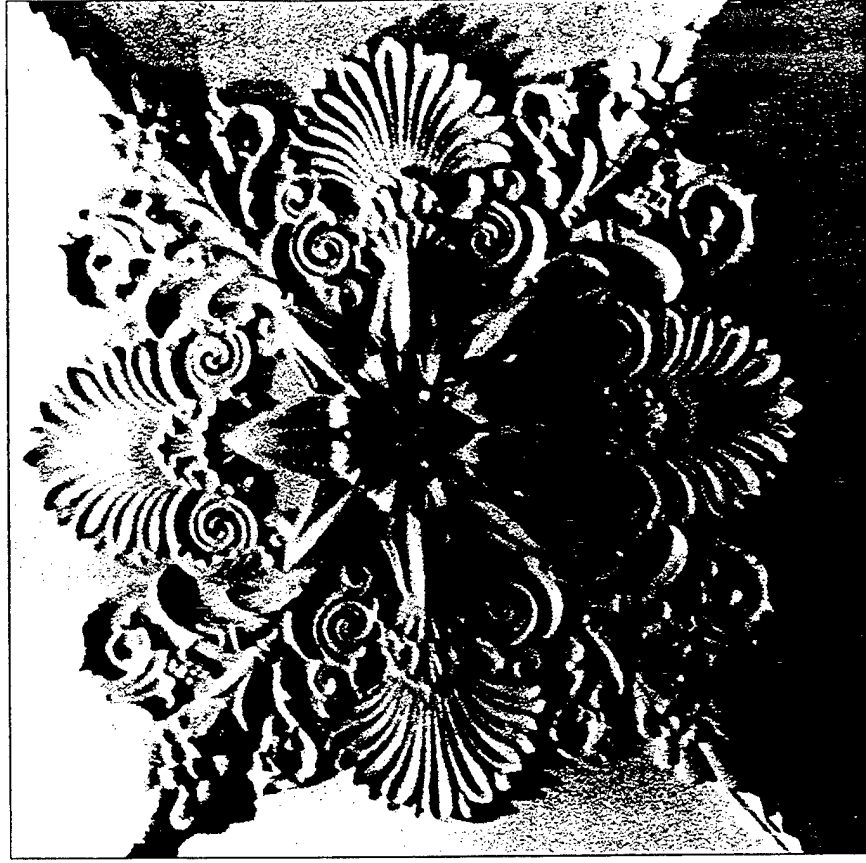

GATE FASTENINGS

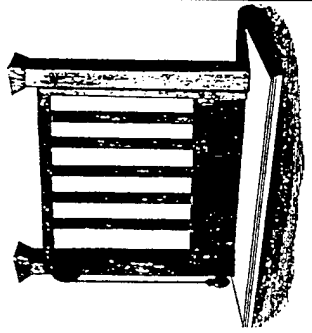

Program/Training Information

Federal Historic Preservation Laws. Sara K. Blumenthal, Ed. Lists the major historic preservation laws that govern a national program to coordinate and support public and private efforts to identify, evaluate, and protect our historic and archeological resources. 59 pages. 1990.

Interpreting the Secretary of the Interior's Standards for Rehabilitation. Michael J. Auer, Ed. Explains how the National Park Service applies the Standards in its administration of the historic preservation tax incentives program. 33 project bulletins. 150 illustrations. 1988.

Preservation Tax Incentives for Historic Buildings. Explains Federal tax incentives available to owners who rehabilitate commercial historic structures. Includes an outline of the certification process, program regulations, and a list of State Historic Preservation Officers. 24 pages. Revised 1990.

Preservation Briefs

Preservation Briefs assist owners and developers of historic buildings in recognizing and resolving common preservation and repair problems prior to work. The briefs are especially useful to preservation tax incentive program applicants because they recommend those methods and approaches for rehabilitating historic buildings that are consistent with their historic character.

Preservation Briefs 1: The Cleaning and Waterproof Coating of Masonry Buildings. Robert C. Mack, AIA. Provides guidance on cleaning and waterproofing techniques and explains the consequences of their inappropriate use. 4 pages. 5 illustrations. 1975.

Preservation Briefs 2: Repointing Mortar Joints in Historic Brick Buildings. Robert C. Mack, AIA, de Teel Paterson Tiller, and James S. Askins. Provides information on appropriate materials and methods for repointing historic brick buildings. 8 pages. 12 illustrations. 1980.

Preservation Briefs 3: Conserving Energy in Historic Buildings. Baird M. Smith, AIA. Provides information on materials and techniques to consider or avoid when undertaking weatherization and energy conservation measures in historic buildings. 8 pages. 8 illustrations. 1978.

Preservation Briefs 4: Roofing for Historic Buildings. Sarah M. Sweetser. Provides a brief history of the most commonly used roofing materials in America. Presents a sound preservation approach to roof repair, roof replacement, and the use of alternative roofing materials. 8 pages. 16 illustrations. 1978.

Preservation Briefs 5: The Preservation of Historic Adobe Buildings. Provides information on the traditional materials and construc-

GATE HINGES AND FASTS.
To Swing Both Ways, and Self-Shutting.

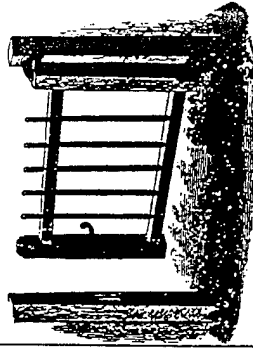

tion of adobe buildings, and the causes of adobe deterioration. Makes recommendations for preserving historic adobe buildings. 8 pages. 15 illustrations. 1978.

Preservation Briefs 6: Dangers of Abrasive Cleaning to Historic Buildings. Anne E. Grimmer. Cautions against the use of sandblasting to clean various building materials and suggests measures to mitigate the effects of improper cleaning. Explains the limited circumstances under which abrasive cleaning may be appropriate. 8 pages. 10 illustrations. 1979.

Preservation Briefs 7: The Preservation of Historic Glazed Architectural Terra-Cotta. de Teel Patterson Tiller. Discusses deterioration problems that commonly occur with terra-cotta and provides methods for determining the extent of such deterioration. Makes recommendations for maintenance and repair, and suggests appropriate replacement materials. 8 pages. 11 illustrations. 1979.

Preservation Briefs 8: Aluminum and Vinyl Siding on Historic Buildings: The Appropriateness of Substitute Materials for Resurfacing Historic Wood Frame Buildings. John H. Myers, revised by Gary L. Hume. Discusses various types of historic wood siding and repair and replacement in kind. Outlines the instances under which substitute siding may be an acceptable alternative. 7 pages. 5 illustrations. Rev. 1984.

Preservation Briefs 9: The Repair of Historic Wooden Windows. John H. Myers. Provides

useful information on evaluating and repairing historic wooden windows found in typical rehabilitation projects. Emphasizes practical methods for homeowners or developers. 8 pages. 10 illustrations. 1981.

Preservation Briefs 10: Exterior Paint Problems on Historic Woodwork. Kay D. Weeks and David W. Look, AIA. Identifies and describes common types of paint surface conditions and failures. Provides guidance on preparing historic woodwork for repainting, including limited and total paint removal. 12 pages. 14 illustrations. 1982.

Preservation Briefs 11: Rehabilitating Historic Storefronts. H. Ward Jandl. Explores the role of the storefront in historic buildings and provides guidance on rehabilitation techniques for historic storefronts as well as compatible new storefront designs. 12 pages. 12 illustrations. 1982.

Preservation Briefs 12: The Preservation of Historic Pigmented Structural Glass (Vitrolite and Carrara Glass). Provides information on the early manufacture, installation, and use of this decorative building product commonly found in 20th century buildings; reasons for its damage; and a general approach for its maintenance, repair, and replacement. 8 pages. 16 illustrations. 1984.

Preservation Briefs 13: The Repair and Thermal Upgrading of Historic Steel Windows. Sharon C. Park, AIA. Presents brief historical background on the development, use, and styles of rolled steel windows popular in the first half

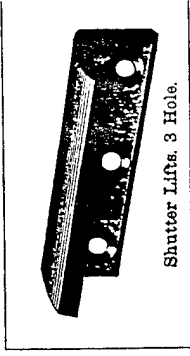

Shutter Lifts. 3 Holes.

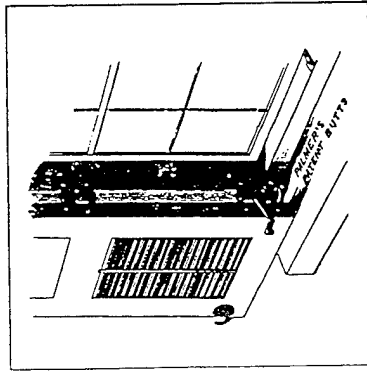

of the 20th century. Explains steps for cleaning and repairing damaged steel windows; also provides information on appropriate methods of weatherstripping and options for storm panels or the installation of thermal glass. 12 pages. 10 illustrations. 1984.

Preservation Briefs 14: New Exterior Additions to Historic Buildings: Preservation Concerns. Kay D. Weeks. Uses a series of examples to suggest ways that attached new additions can successfully serve contemporary uses as part of a rehabilitation project while preserving significant historic materials and features and the building's historic character. 12 pages. 30 illustrations. 1986.

Preservation Briefs 15: Preservation of Historic Concrete: Problems and General Approaches. William B. Coney, AIA. Focuses on cast-in-place and reinforced concrete. The guidance addresses the causes of concrete deterioration, the signs of deterioration, and actual concrete repair. 12 pages. 27 illustrations. 1987.

Preservation Briefs 16: The Use of Substitute Materials on Historic Building Exteriors. Sharon C. Park, AIA. Includes a discussion of when to use substitute materials, cautions regarding their expected performance, and descriptions of several substitute materials together with their advantages and disadvantages. Summary charts are included. 14 pages. 34 illustrations. 1988.

Preservation Briefs 17: Architectural Character—Identifying the Visual Aspects of Historic

Buildings as an Aid to Preserving Their Character. Lee H. Nelson, FAIA. Essential guidance to help property owners and architects identify those features of historic buildings that give the building its visual character so that their preservation can be maximized in rehabilitation. 12 pages. 27 illustrations. 1988.

Preservation Briefs 18: Rehabilitating Interiors in Historic Buildings—Identifying Character-Defining Elements. H. Ward Jandl. Assists building owners in identifying significant interior spaces, features, and finishes so they may be preserved in rehabilitation work. The guidance applies to all building types and styles, from 18th century churches to 20th century office buildings. 8 pages. 11 illustrations. 1988.

Preservation Briefs 19: The Repair and Replacement of Historic Wooden Shingle Roofs. Sharon C. Park, AIA. Discusses historic wooden roofing, expectations for longevity, and repair and replacement options. Identifies roofing material that duplicates the appearance of a historic roof, offers guidance on proper installation, and provides information on coatings and maintenance procedures to help preserve the new roof. 12 pages. 16 illustrations. 1989.

Preservation Briefs 20: The Preservation of Historic Barns. Michael J. Auer. Identifies historic barn types, helps owners understand the historic character of their barns, and offers advice on the maintenance, repair, and rehabilitation of old and historic barns. 12 pages. 30 illustrations. 1989.

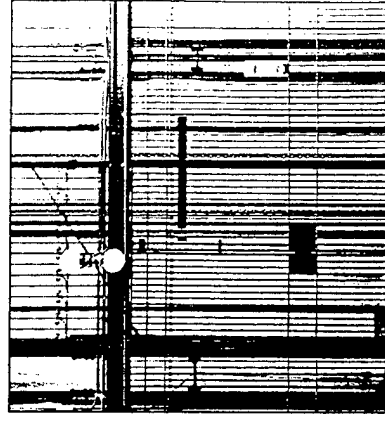
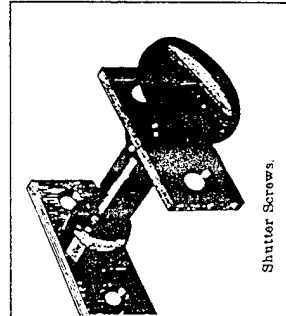

Photo: Richard Nickel, HAHS



Shattler Screws.

Preservation Briefs 21: Repairing Historic Flat Plaster—Walls and Ceilings. Marylee MacDonald. Guides building owners on repairing historic plaster using traditional materials and techniques. Suggests replacement options if the historic plaster is severely deteriorated. Useful chart on various plaster bases and compatible basecoats and finish coats. 14 pages. 17 illustrations. 1989.

Preservation Briefs 22: The Preservation and Repair of Historic Stucco. Anne E. Grimmer. Describes the evolution of stucco as a popular building material, beginning with a brief history of how stucco is applied, and how its composition, texture, and surface patterns have changed. Includes guidelines for the historic property owner or manager on repairing historic stucco, with sample mixes for 18th, 19th, and 20th century stucco types. 16 pages. 33 illustrations. 1990.

Preservation Briefs 23: Preserving Historic Ornamental Plaster. David Flaharty. Explains the processes of run-in-place and cast ornamentation by using three common decorative forms as examples: the cornice, ceiling medallion, and coffered ceiling. Illustrates common causes of plaster deterioration and repair techniques. Useful advice on selecting and evaluating a restoration contractor is included. 14 pages. 34 illustrations. 1990.

Preservation Briefs 24: Heating, Ventilating, and Cooling Historic Buildings: Problems and Recommended Approaches. Sharon C. Park, AIA. Outlines the history of mechanical systems

from the 18th c. to the early 20th c. Discusses issues involving occupant comfort and climate control. Underscores the importance of careful planning in order to balance preservation objectives with the interior climate needs of historic buildings. Useful chart included that gives an overview of contemporary HVAC systems together with advantages and disadvantages. 12 pages. 17 illustrations. September, 1991.

Preservation Briefs 25: The Preservation of Historic Signs. Michael J. Auer. Reviews sign types and practices from the 18th c. to the 1960's. Discusses the complex issues involved in repairing and re-using historic signs for contemporary businesses. 12 pages. 30 illustrations. September, 1991.

Preservation Briefs 26: The preservation and Repair of Historic Log Buildings. Bruce D. Bomberger. Reviews and illustrates historic log construction from the 18th c. to the early 20th c., focusing on horizontally-laid logs. Discusses traditional splicing-in techniques, the use of epoxies, and log replacement, as well as guidance on the repair and replacement of chinking and daubing. 16 pages. 25 illustrations. September, 1991.

Preservation Briefs 27: The Maintenance and Repair of Architectural Cast Iron. John G. Waite, AIA. Historical Overview by Margot Gayle. Discusses cast iron in terms of 19th century industrial development. Emphasizes the importance of this versatile material in architectural building design, technology, and ornamentation. Provides essential guidance on maintain-

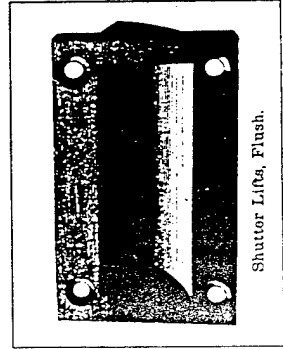
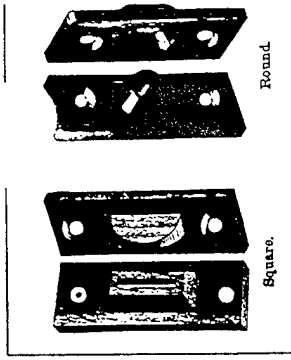

ing and repairing architectural cast iron within rehabilitation projects. 14 pages. 25 illustrations. September, 1991.

Technical Reports

Technical Reports address in detail problems confronted by architects, engineers, government officials, and other technicians involved in the preservation of historic buildings.

A Glossary of Historic Masonry Deterioration Problems and Preservation Treatments. Anne E. Grimmer. Generously illustrated, provides information on 22 common masonry deterioration problems and their known treatments. Intended for use both as a general reference tool and an on-site interpretive guide in the maintenance and preservation of historic structures. 68 pages. 41 illustrations. 1984. Bibliography.

Access to Historic Buildings for the Disabled: Suggestions for Planning and Implementation. Charles Parrott. Describes methods to achieve barrier-free access to historic buildings that conform with the Department of the Interior's historic preservation standards. Addresses a variety of specific needs for the disabled, including ramps, vertical wheelchair lifts, curb cuts, railings, restrooms, miscellaneous fixtures, and signs. Also examines techniques to make programs and services housed in historic buildings accessible in lieu of architectural changes. 92 pages. 42 illustrations. 1980. Bibliography.

Cyclical Maintenance for Historic Buildings. J. Henry Chambers, AIA. Provides a step-by-step process for building managers, architects, and others involved in the routine maintenance of historic properties. 125 pages. 1976. Bibliography.

Epoxies for Wood Repairs in Historic Buildings. Morgan W. Phillips and Dr. Judith E. Selwyn. Presents research findings on the use of epoxies to preserve historic wood features rather than replacing them. Discusses low-viscosity epoxy consolidants that can be soaked into rotted wood in order to restore its solidity; and epoxy pastes for filling holes and cracks in historic woodwork. Includes useful case-study applications, suggested formulations, and lists of suppliers. 72 pages. 43 illustrations. Appendix. 1978.

Gaslighting in America: A Pictorial Survey, 1815-1910. Denys Peter Myers. Surveys the types and style of gas fixtures that appeared in the rooms and on the streets of 19th and early 20th century America. 279 pages. 120 illustrations. Originally published by the National Park Service in 1978, re-issued by Dover Press, New York, in 1990.

Keeping it Clean: Removing Dirt, Paint, Stains, and Graffiti from Historic Exterior Masonry. Anne E. Grimmer. Covers virtually every aspect of a cleaning project—identifying building materials to be cleaned and ones that might be affected by cleaning; scheduling cleaning around other work; what to ask for in cleaning "specs;" and what kind of test cleaning procedures to use. Useful chart summarizes

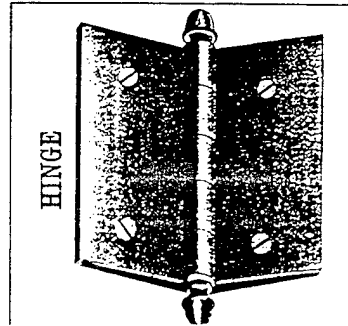
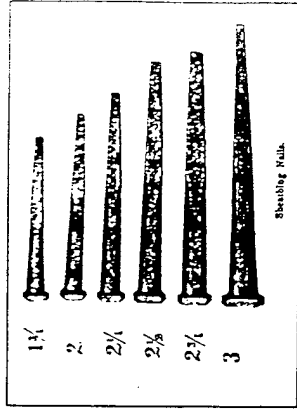

cleaners and removal techniques. 45 pages. 35 illustrations. Bibliography.

Metals in America's Historic Buildings: Uses and Preservation Treatments. Margot Gayle and David W. Look, AIA. One of the most complete sourcebooks available on historic architectural metals, such as lead, tin, zinc, bronze, copper, iron, nickel, steel and aluminum. Part 1 focuses on the identification and historic uses of architectural metals; Part 2 provides in-depth information on repair and preservation methods, discussing each metal individually. 168 pages. 180 illustrations. Bibliography. 1980.

Moisture Problems in Historic Masonry Walls: Diagnosis and Treatment. Baird M.

Smith, AIA. Intended for architects, building owners, property managers, and others responsible for the care and maintenance of historic buildings. Discusses problems caused by excessive moisture in historic masonry walls and outlines a methodology for diagnosing such problems and selecting appropriate treatments. 48 pages. 32 illustrations. 1984. Bibliography.

Moving Historic Buildings. John Obed Curtis.

Discusses the limited circumstances under which a historic masonry or frame building should be moved. Establishes a methodology for planning, research, and recording prior to the move; and addresses the siting, foundation construction, building reassembly, and restoration work after a successful move has taken place. 50 pages. 47 illustrations. Bibliography.

Photogrammetric Recording of Cultural Resources. Perry E. Borchers. Describes the basic principles of photogrammetry and their application to the recording of cultural resources. Includes several case study applications. 38 pages. 27 illustrations. Bibliography. 1977.

Rectified Photography and Photo Drawings for Historic Preservation. J. Henry Chambers, AIA. Explains the process of making photographic negatives of a predetermined size or scale which can be enlarged to a convenient architectural scale, then printed on photo-sensitive drafting film for working drawings, surveys, and feasibility studies. 38 pages. 13 illustrations. 1973.

Using Photogrammetry to Monitor Materials Deterioration and Structural Problems on Historic Buildings: Dorchester Heights Monument, A Case Study. J. Henry Chambers, AIA. Details the cost-effectiveness of close-range photogrammetry in monitoring the condition of historic masonry structures, particularly when more conventional methods of inspection are impracticable. 16 pages. 6 illustrations. Bibliography. 1985.

X-Ray Examination of Historic Structures.

David M. Hart. Explains a method for nondestructive probing of historic buildings that permits investigation of components normally hidden from view. Intended for architects, conservators, and other professionals. 24 pages. 19 illustrations. Bibliography. 1975.



Photo: Pro Hydrat

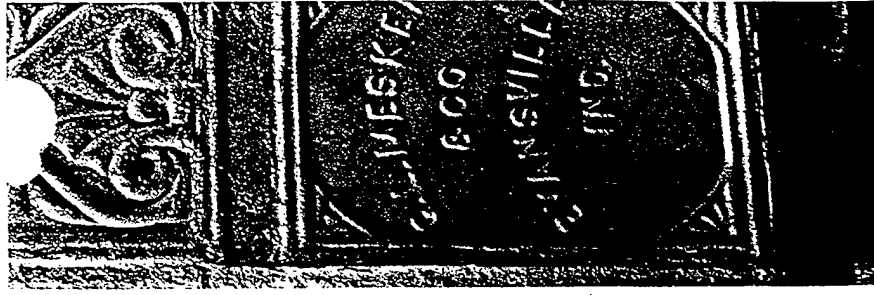

Photo: Jack E. Borchers

Preservation Case Studies

Preservation Case Studies provide practical, solution-oriented information for developers, planners, and owners by presenting and illustrating a specific course of action taken to preserve one building or an entire block of buildings. Individual case studies may highlight an innovative rehabilitation technique, financing strategies, or an overall planning methodology.

Abbeville, South Carolina: Rehabilitation Planning and Project Work the Commercial Town Square. John M. Bryan and the Triad Architectural Associates. Excellent planning guide for historic building owners interested in rehabilitating an entire block to enhance local commercial trade. Uses a series of architectural drawings and sketches, recommends preservation work for each building inventoried as well as the urban setting. 55 pages. 24 illustrations. 1979.

Fort Johnson, Amsterdam, New York: A Historic Structure Report. Mendel-Mesick-Cohen. From an on-site inspection conducted in 1974-1975, shows steps to take prior to undertaking preservation or restoration work on a historic building. Documents the current state of the building's exterior and interior materials and overall structural stability. Recommends work that meets the Department of Interior's historic preservation standards. Archeological report included. 54 pages. 89 illustrations. Appendices. 1978.

Main Street Historic District, Van Buren, Arkansas: Storefront Rehabilitation/Restoration Within a Districtwide Plan. Susan Guthrie. Illustrates in detail how storefronts in a small town's commercial center were successfully rehabilitated. Emphasizes both planning and rehabilitation by inclusion of working drawings, and before, during and after photographs. 31 pages. 30 illustrations. 1980.

Maymont Park-The Italian Garden, Richmond, Virginia: Landscape Restoration. Barry W. Starke, ASLA. Outlines step-by-step process of conducting historical research on a National Register-listed park, preparing existing conditions documentation, and recommending project work. Includes the landscape architect's drawings and specifications to restore stone walls, garden walkways, and domed pergola according to Department of the Interior historic preservation standards. 39 pages. 29 illustrations. 1980.

Planning for exterior Work on the First Parish Church, Portland, Maine, Using Photographs as Project Documentation. John C. Hecker, AIA, and Sylvanus W. Doughty. Using annotated photographs detailing physical damage and deterioration of a specific church building, shows how project work recommendations were made. Useful methodology for owners and developers planning rehabilitation work on any building. Includes architectural specifications for several work areas, such as site improvements, mortar, brick masonry, rough carpentry, slate roofing, dampproofing,

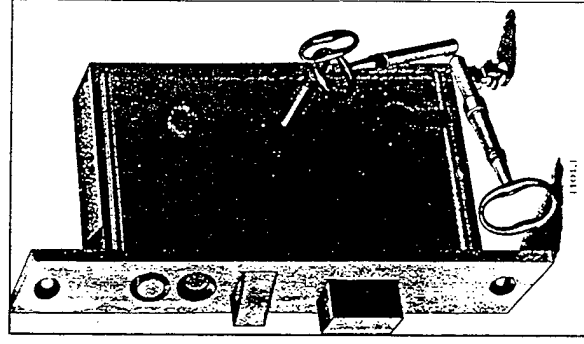
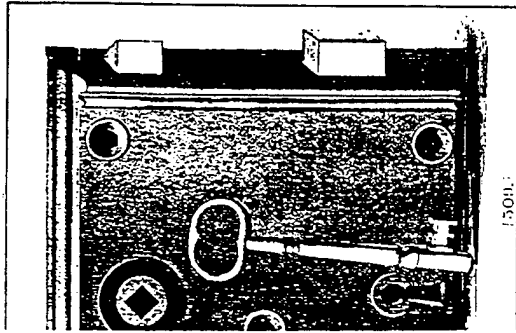

flashing, and painting. 58 pages. 15 illustrations. Secretary of the Interior's Standards as Appendix. 1979.

Olmsted Park System, Jamaica Pond Boathouse, Jamaica Plain, Massachusetts: Planning for the Preservation of the Boathouse Roof. Richard White. Focuses on planning the preservation of a specific public park building, but useful for planning an entire project to meet Department of Interior historic preservation standards. Presents a responsible process of documenting proposed work, including a brief history of the site and building, evaluation of deterioration, architectural drawings, and a summary of successful completed work. 58 pages. 25 illustrations. Appendix. 1979.

Rehabilitating Historic Hotels: Peabody Hotel, Memphis, Tennessee. Floy A. Brown. Explains use of the preservation tax credit to rehabilitate an important downtown hotel. Outlines the success of other hotel rehabilitations across the United States, then focuses on the Peabody Hotel in Memphis. The case study describes the Peabody's architectural importance, the scope of rehabilitation work, and the funding initiative. 44 pages. 21 illustrations. Appendix. 1979.

The Morse-Libby Mansion: A Report on Restoration Work, 1973-1977. Morgan W. Phillips. Describes and illustrates preservation methods and techniques used in the exterior restoration of an Italianate mansion. 55 pages. 84 illustrations. Appendices. 1977.

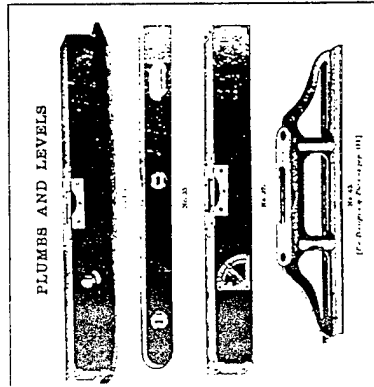

Preservation Tech Notes

Preservation Tech Notes (PTN) provide innovative solutions to specific problems in preserving cultural resources—buildings, structures, and objects. Tech Notes are intended for practitioners in the preservation field, including architects, contractors, and maintenance personnel, as well as for owners and developers seeking the preservation tax investment credit for rehabilitation. Topic categories for this series to date include doors, windows, finishes, interior spaces, mechanical systems, museum collection storage, temporary protection, exterior woodwork, masonry, and metals.

PTN 1 Windows(1): Planning Approaches to Window Preservation by Charles E. Fisher. January, 1984.

PTN 2 Windows(2): Installing Insulating Glass in Existing Steel Windows by Charles E. Fisher. January, 1984.

PTN 3 Windows(3): Exterior Storm Windows: Casement Design Wooden Storm Sash by Wayne Trissler and Charles E. Fisher. January, 1984.

PTN 4 Windows(4): Replacement Wooden Frames and Sash: Protecting Woodwork Against Decay by William C. Feist. January, 1984.

PTN 5 Windows(5): Interior Metal Storm Windows by Laura A. Muckenfuss and Charles E. Fisher. January, 1984.

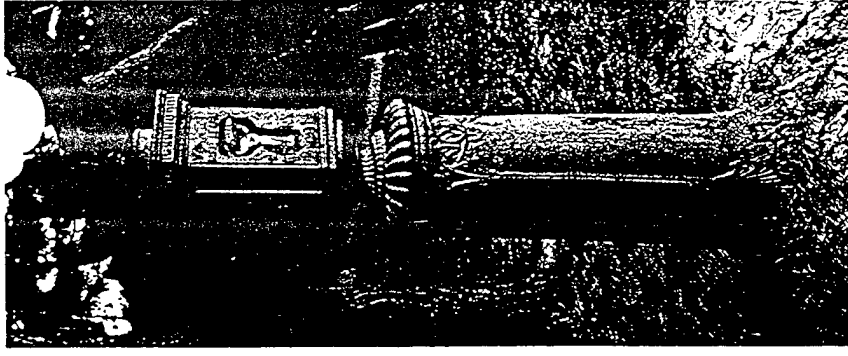

Photo: Jack E. Boucher.

PTN 6 Windows(6): Replacement Wooden Sash and Frames with Insulating Glass and Integral Muntins by Charles Parrott. January, 1984.

PTN 7 Windows(7): Window Awnings by Laura A. Muckenfuss and Charles E. Fisher. September, 1984.

PTN 8 Windows(8): Thermal Retrofit of Historic Wooden Sash Using Interior Piggy-back Storm Panels by Sharon C. Park, AIA. September, 1984.

PTN 9 Windows(9): Interior Storm Windows: Magnetic Seal by Charles E. Fisher. September, 1984.

PTN 10 Temporary Protection(1): Temporary Protection of Historic Stairways During Rehabilitation Work by Charles E. Fisher. March, 1985.

PTN 11 Windows(10): Temporary Window Vents in Unoccupied Historic Buildings by Charles E. Fisher and Thomas A. Vitanza. August, 1985.

PTN 12 Windows(11): Installing Insulating Glass in Existing Wooden Sash Incorporating the Historic Glass by Charles E. Fisher. September, 1985.

PTN 13: Not issued.

PTN 14 Museum Collections(1): Museum Collection Storage in a Historic Building Using a Prefabricated Structure by Don Cumberland, Jr.. September, 1985.

PTN 15 Windows(13): Aluminum Replacement Windows with Sealed Insulating Glass and Trapezoidal Muntin Grids by Charles Parrott. September, 1985.

PTN 16 Historic Interior Spaces(1): Preserving Historic Corridors in Open Office Plans by Christina Henry. October, 1985.

PTN 17 Exterior Woodwork(1): Proper Painting and Surface Preparation by Sharon C. Park, AIA. May, 1986.

PTN 18 Exterior Woodwork(2): Paint Removal from Wood Siding by Alan O'Bright. September, 1986.

PTN 19 Windows(14): Reinforcing Deteriorated Wooden Windows by Paul Stumes, P. Eng. November, 1986.

PTN 20 Windows(15): Interior Storms for Steel Casement Windows by Charles E. Fisher and Christina Henry. November, 1986.

PTN 21 Windows(16): Repairing and Upgrading Multi-Light Wooden Mill Windows by Christopher Closs. December, 1986.

PTN 22 Windows(12): Aluminum replacement for Steel Industrial Sash by Charles E. Fisher. December, 1986.

PTN 23 Masonry(1): Substitute Materials: Replacing Deteriorated Serpentine Stone with Pre-Cast Concrete by Robert M. Powers. September, 1988.

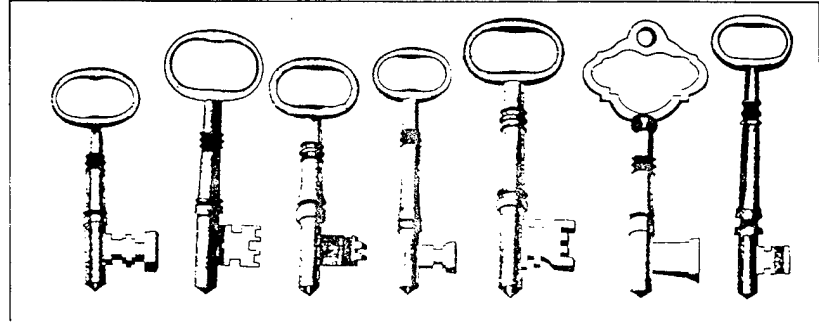
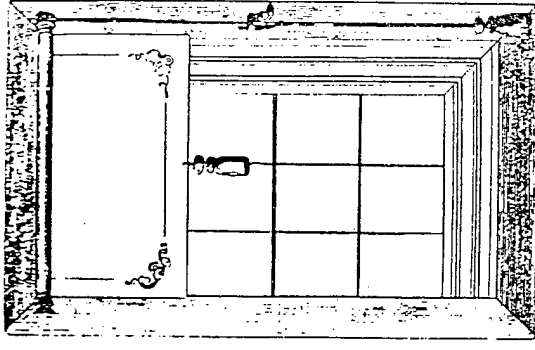

PTN 24 Mechanical Systems(1): Replicating Historic Elevator Enclosures by Marilyn E. Kaplan, AIA. June, 1989.

PTN 25 Doors(1): Historic Garage and Carriage Doors: Rehabilitation Solutions by Bonnie J. Haldal, AIA. July, 1989.

PTN 26 Historic Interior Spaces(2): Preserving Historic Office Building Corridors by Thomas G. Keohan. July, 1989.

PTN 27 Metals(1): Conserving Outdoor Bronze Sculpture by Dennis R. Montagna. August, 1989.

PTN 28 Exterior Woodwork (3): Log Crown Repair and Selective Replacement Using Epoxy and Fiberglass Reinforcing Rods by Harrison Goodall. September, 1989.

PTN 29 Windows(17): Repair and Retrofitting Industrial Steel Windows by Robert M. Powers. August, 1989.

PTN 30 Museum Collection(2): Reducing Visible and Ultraviolet Light Damage to Interior Wood Finishes by Ron Sheets and Charles E. Fisher. September, 1990.

PTN 31 Finishes(1): Process Painting Decals as a Substitute for Hand-Stencilled Ceiling Medallions by Sharon C. Park, AIA. September, 1990.

PTN 32 Metals(2): Restoring Stamped Zinc and Galvanized Steel Roof Cornices by Richard Pieper. September, 1990.

PTN 33 Metals(3): In-kind Replacement of Historic Stamped-Metal Exterior Siding by Rebecca A. Shiffer. September, 1991.

PTN 34 Masonry(2): Stabilization and Repair of a Historic Terra Cotta Cornice by Jeffrey S. Levine and Donna Ann Harris. September, 1991.

PTN 35 Site(1): Restoring Vine Coverage to Historic Buildings by Karen E. Day. October, 1991.

PTN 36 Windows(19): Aluminum Replacement With True Divided Lights, Interior Piggyback Storms, and Exposed Historic Wooden Frames by Charles Parrott. October, 1991.



FLUSH RINGS

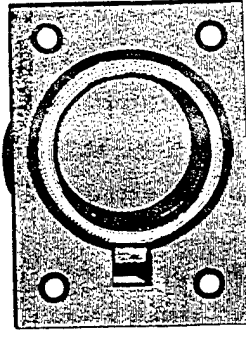

Flush Rings, for Sliding Barn and Trap Doors.

Co-Published Books

Interiors Handbook for Historic Buildings. National Park Service and the Historic Preservation Education Foundation (HPEF). Charles E. Fisher, Ed. Prepared for a national conference on appropriate interior treatments for historic buildings, includes nearly 400 pages of technical papers as well as guidance for architects, developers, building managers, curators, and property owners. Addresses both rehabilitation and restoration issues, including inspection, evaluation and planning, architectural features and materials, systems and fixtures, space utilization and adaptive reuse, finishes and decorative accessories, and fire protection and building codes. 550 pages. Illustrated. 1988.

Respectful Rehabilitation: Answers to Your Questions on Historic Buildings. National Park Service and National Trust for Historic Preservation. Kay D. Weeks and Diane Maddex, Eds. Provides answers to 150 questions often asked in rehabilitating historic buildings for new uses. 185 pages. 150 illustrations. Bibliography. 1982.

The Window Handbook: Successful Strategies for Rehabilitating Windows in Historic Buildings. National Park Service and the Center for Architectural Conservation, Georgia Institute of Technology. Charles E. Fisher, Ed. 16 Preservation Tech Notes on windows. 262 pages. Illustrated. Appendices. 1986.

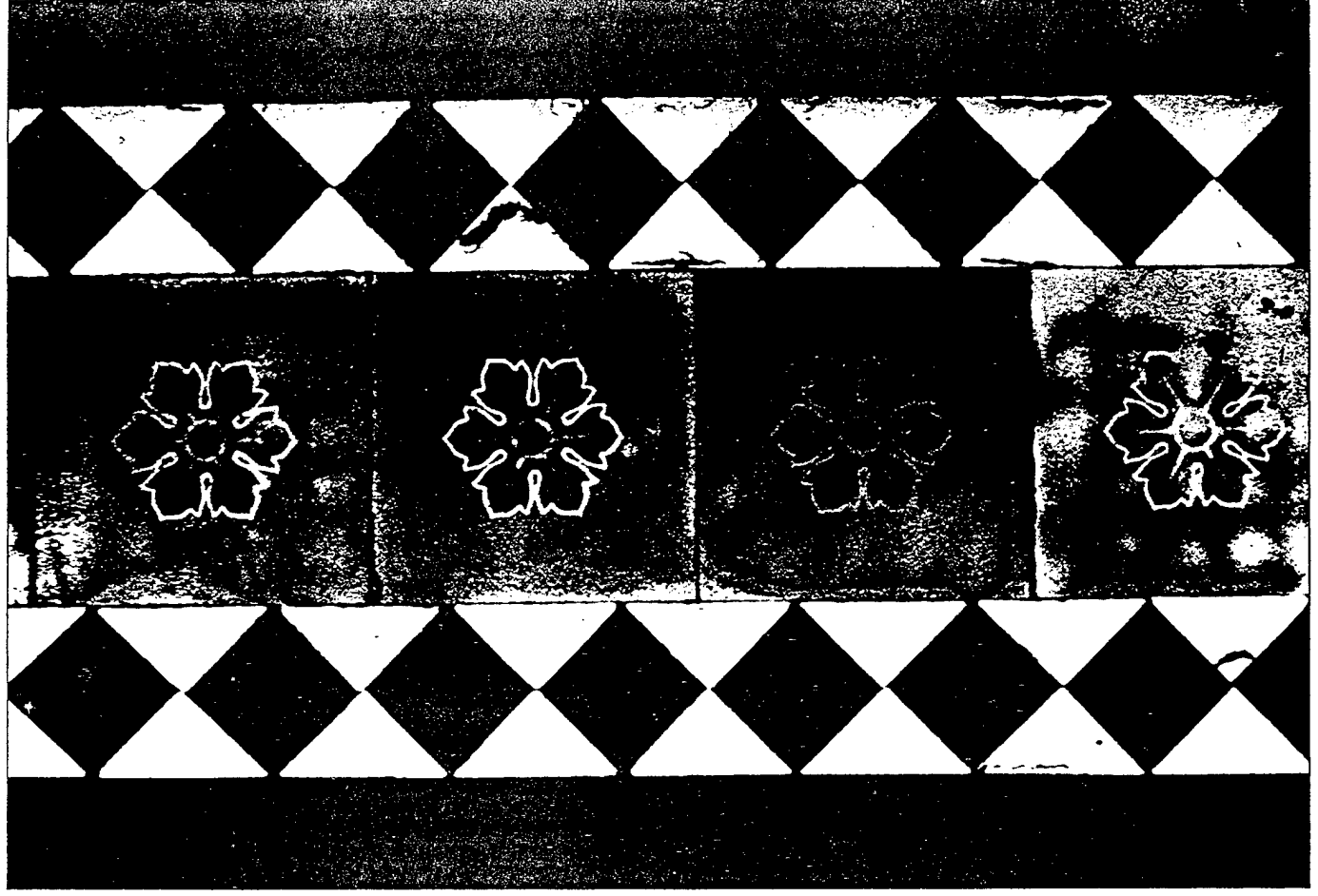

NPS Regions and Washington Office Information

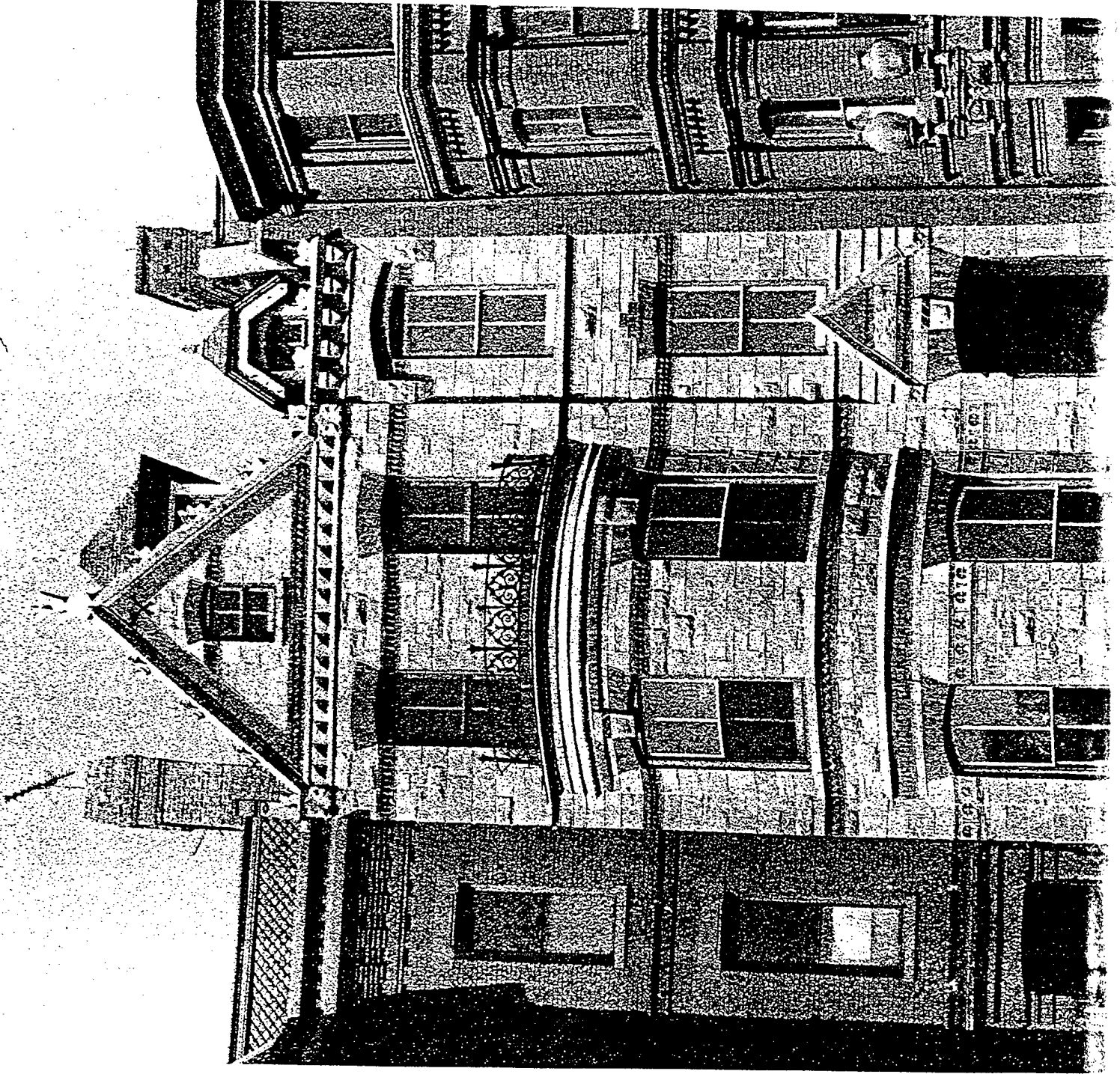

NPS Regions and Washington Office Information

UNITED STATES DEPARTMENT OF THE INTERIOR
NATIONAL PARK SERVICE
P.O. Box 37127

Washington, DC 20013-7127

Office of the Director — (202) 208-4621/FTS 268-4621

Office of Public Affairs — (202) 208-6843/FTS 268-6843

Preservation Assistance Division — (202) 343-9578/FTS 343-9578

Mid-Atlantic Region

143 South Third Street

Philadelphia, PA 19106

Regional Director: FTS 8-597-7013

Public Information Office:

FTS 8-597-3679 or (215) 597-3679

Rocky Mountain Region

P.O. Box 25287

Denver, CO 80225-0287

Regional Director: FTS 8-969-2500

Public Information Office:

FTS 8-327-2503 or (303) 969-2503

Midwest Region

1709 Jackson Street

Omaha, NE 68102

Regional Director: FTS 8-864-3431

Public Information Office:

FTS 8-864-3448 or (402) 221-3448

Southeast Region

75 Spring Street, SW

Atlanta, GA 30303

Regional Director: FTS 8-242-5185

Public Information Office:

FTS 8-242-4998 or (404) 331-4998

North Atlantic Region

15 State Street

Boston, MA 02109

Regional Director: FTS 8-223-5001

Public Information Office:

FTS 8-223-5200 or (617) 223-5200

Southwest Region

P.O. Box 728

Santa Fe, NM 87504-0728

Regional Director: FTS 8-476-6388

Public Information Office:

FTS 8-476-6375 or (505) 988-6375

National Capitol Region
1100 Ohio Drive, SW
Washington, DC 20242
Regional Director: FTS 8-426-6612
Public Information Office:
FTS 8-485-9666 or (202) 485-9666

Western Region
600 Harrison Street
Suite 600, Box 36063
San Francisco, CA 94107-1372
Regional Director: FTS 8-484-3876
Public Information Office:
FTS 8-484-3929 or (415) 744-3929

Pacific Northwest Region
83 South King Street
Suite 212
Seattle, WA 98104
Regional Director: FTS 8-399-5565
Public Information Office:
FTS 8-399-5622 or (206) 442-5622

Alaska Region
2525 Gambell Street
Anchorage, AK 99503-2892
Regional Director: FTS 8-907-257-2690
Public Information Office:
FTS 8-907-257-2696

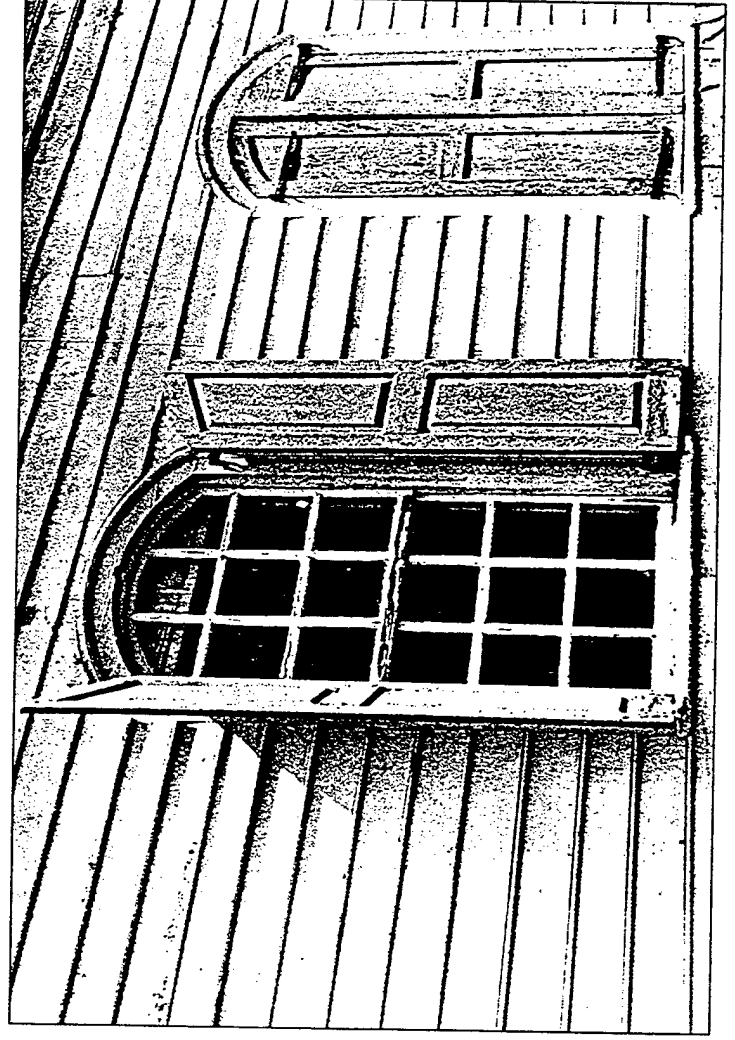

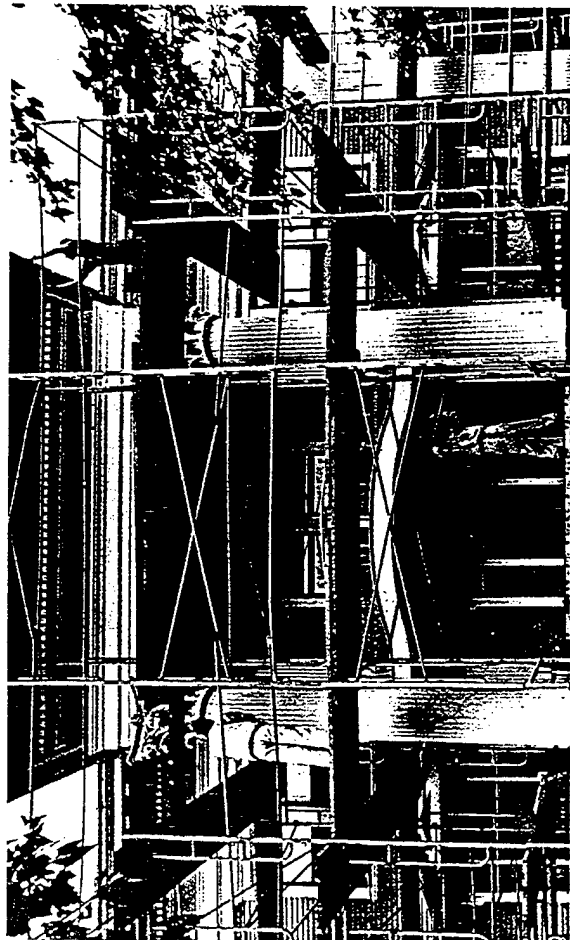

Photo: Jack E. Boucher, HABS

Preservation Assistance Division, NPS, Washington Office, 1990

*"The many awards garnered by
historic rehabilitation projects
throughout the Nation are testimony
to the value of the Secretary's
Standards and Guidelines."*

*Nellie Longworth
President
Preservation Action*



PRESERVATION TECH NOTES

Exterior Wood Work No. 2: Paint Removal from Wood Siding.

Temporary Protection No. 1: Temporary Protection of Historic Stairways during Rehabilitation Work.

Temporary Protection No. 2: Specifying Temporary Protection of Historic Interiors during Construction and Repair.

Windows No. 6: Replacement Wooden Sash and Frames with Insulating Glass and Integral Muntin.

Windows No. 18: Aluminum Replacement Windows with True Divided Lights, Interior Piggyback Storm Panels, and Exposed Historic Wooden Frames.

Tech Notes

NATIONAL PARK SERVICE
U.S. DEPARTMENT OF THE INTERIOR
WASHINGTON, D.C.

EXTERIOR WOODWORK

NUMBER 2

Paint Removal from Wood Siding

Alan O'Bright
Midwest Regional Office
National Park Service



TRUMAN HOME HARRY S TRUMAN NATIONAL HISTORIC SITE Independence, Missouri

Harry S Truman National Historic Site anchors one end of a local historic residential district in the city of Independence, located just east of Kansas City, Missouri. The Truman home was constructed in three major phases. The initial pre-Civil War construction is believed to have consisted of a simple two-story rectangular structure. Major additions in 1867 and 1884 enlarged the building to 15 rooms, totaling approximately 4000 square feet. Characteristic of the early Queen Anne style, the wood-sided exterior of the 2½ story frame home was embellished with over 200 wooden brackets, decorative jig-sawn porch frieze boards, and layered cornice mouldings.

The Truman property was willed to the United States upon the death of Mrs. Truman in 1982 and placed under the administration of the National Park Service. Immediate preservation problems such as metal roof replacement, rewiring, and grounds maintenance were accomplished prior to the official opening in May 1984, the centennial of Mr. Truman's birth. Given the nature of the problem, the Ser-

vice delayed the necessary removal of the deteriorated exterior paint and repainting until after the park's opening.

Problem

Examination of the exterior paint finishes in areas directly exposed to the elements revealed severe paint film failure, including cross-grain cracking, alligating, and peeling (see figure 1). Even in places shielded by porches and cornices, moderate paint film failure had occurred. A number of exposed areas, including soffits, fasciae, and siding, experienced near total paint failure due to recurrent moisture penetration from deteriorated roofs and built-in gutters. Windows were also in very poor condition; many exhibited loose glazing, broken glass and rotted sash. More than 20 coats of paint concealed deteriorated woodwork and cladding from direct examination. On much of the projecting mill work, the final layers of paint had been applied so heavily that stalactites in excess of one-quarter inch were apparent due to paint dripping.

On one section of the building, constant moisture penetration from a poorly detailed sleeping porch floor deck had caused total paint failure. Rain water had soaked the wall cavities of a ground floor

Special precautions should be taken when thermally removing paint from historic woodwork to prevent damage and to reduce fire and health risks.

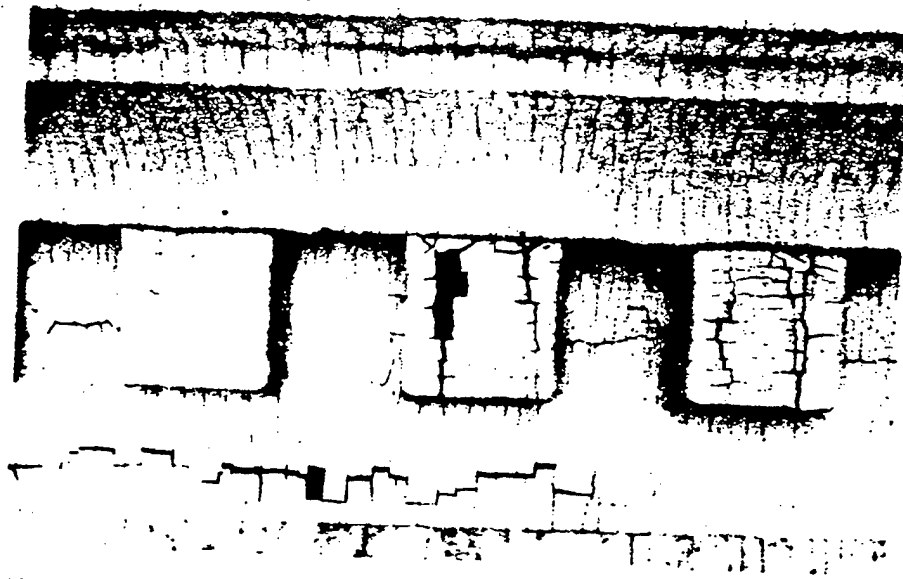

Figure 1. Detail of a cornice dentil shows the severe cracking and failure of paint finish. Photo: Alan O'Bright

bathroom causing the paint to peel off in hand-size sheets. It was clear the exterior finishes had lost most, if not all, of their elastic integrity. In order to achieve a sound surface for painting, the decision was made to remove a majority of the exterior paint finishes to bare wood in preparation for a three-coat paint application.

Solution

As part of the planning required before the selection of the paint removal method, a physical investigation was conducted of the exterior structure to determine the method of construction and condition (see figure 2). This is particularly critical whenever paint removal is planned. Decisions as to which paint removal methods will be used—especially methods involving heat—are in part guided by the potential flammability of the wall material and debris in the wall cavity and cornices. Sections of lapped siding were carefully removed and the underlying board sheathing cut with a hole saw to reveal the wall cavities. Fortunately, the bulk of the balloon-framed structure was found to be in good condition and the project team believed that potential fire risks could be minimized. With the exception of the 1884 addition, all wall cavities had been filled from foundation sill to soffit with soft brick and mortar. A majority of the house was

sheathed in white pine tongue-and-groove boards.

Three methods of paint removal were considered: hand scraping and sanding, chemical strippers, and thermal removal. Prior experiences with hand scraping and sanding on a large scale had shown this method to be very damaging to wood surfaces and the workmanship very difficult to control.

Chemical strippers are very messy and difficult to control on exterior vertical surfaces. After application, the volatile chemicals usually need to be covered with sheet plastic to keep them from rapidly evaporating.

The use of propane torches to remove the paint was not considered because of the high risk of starting a fire or at least of scorching the wood. Two thermal paint removal techniques, however, were evaluated—radiant heat plates and heat guns. The radiant heat plate gives a consistent heat flow, but heat intensity is less controllable. The plate housing also obstructs the laborer's view of the working surface, making it difficult to tell when the softened paint is ready to remove. If the paint is overheated, it can ignite and scorch the wood as the plate is withdrawn.

The heat gun was chosen because of the following advantages: the heat is controllable; the working surface is exposed to view, allowing better control; and all layers of paint can be softened and removed down to the original surface in one pass without mechanical damage to wood.

Although chemicals and hand scraping were rejected as the primary paint removal method, chemicals and scrapers were used

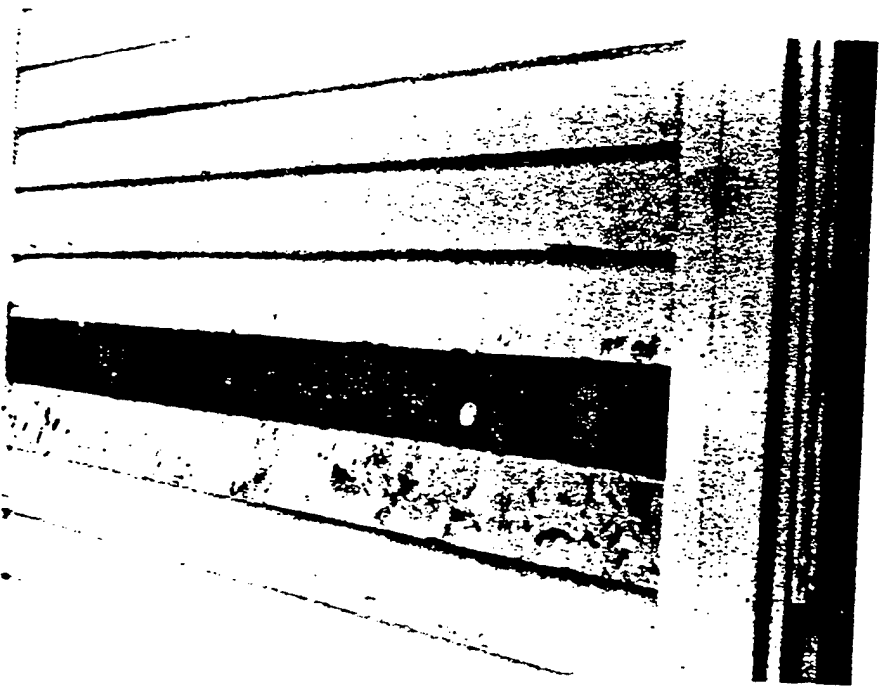

Figure 2. In assessing the safety of using thermal heat to remove paint from the siding, an investigation was performed to determine wall construction and condition. In this portion of the structure, there was no sheathing backing the siding but brick nogging extended from the foundation to the soffit. Photo: Alan O'Bright

in other areas such as porch ceilings, soffits, windows, and brackets, where the working surface was too complex, or where there was a risk of overheating unexplored cavities. The majority of the exterior walls, sheathed or filled with brick nogging, apparently caused the radiant heat to dissipate considerably before reaching wall cavities. Furthermore, the sheathing formed a barrier protecting the wall cavities from direct hot air blast through cracks and joints in the siding and trim. Nevertheless, strict fire precautions still were taken throughout the project.

Tools and Techniques

A heavy-duty heat gun was approved for the contractor's use (see figure 3). The metal encased unit featured variable heat control (500-750° F) through adjustable side vents, and a cool down switch, which extends the life of the replaceable heating elements. Since these elements can have a working life as short as 60 to 80 hours, extra elements were purchased and were available at the site for immediate replacement of those in the five heat guns used in the project.

Each unit operated on its own 20 ampere circuit to prevent constant tripping of breaker switches due to the high energy consumption of the heat guns (14 amps, 120 volts). Temporary weatherproof electrical outlets with ground fault interrupters were installed in the most advantageous locations to prevent voltage drop due to long extension cords.

Workers used alternative paint removal methods on some portions of the structure, including porch ceilings and cornices, because of the increased risk of overheating cavities in these locations. They exercised particular caution around windows and doors where siding butt-joined the trim. An additional concern was the potential for dust and other debris to overheat in the hollow areas behind the casing, such as in the sash weight boxes. For safety, siding paint was removed thermally no closer than 6 inches from window and door trim and alternate paint removal or feathering methods were employed for the remainder. The workers used chemical strippers around glass instead of heat guns to avoid heat stress fractures.

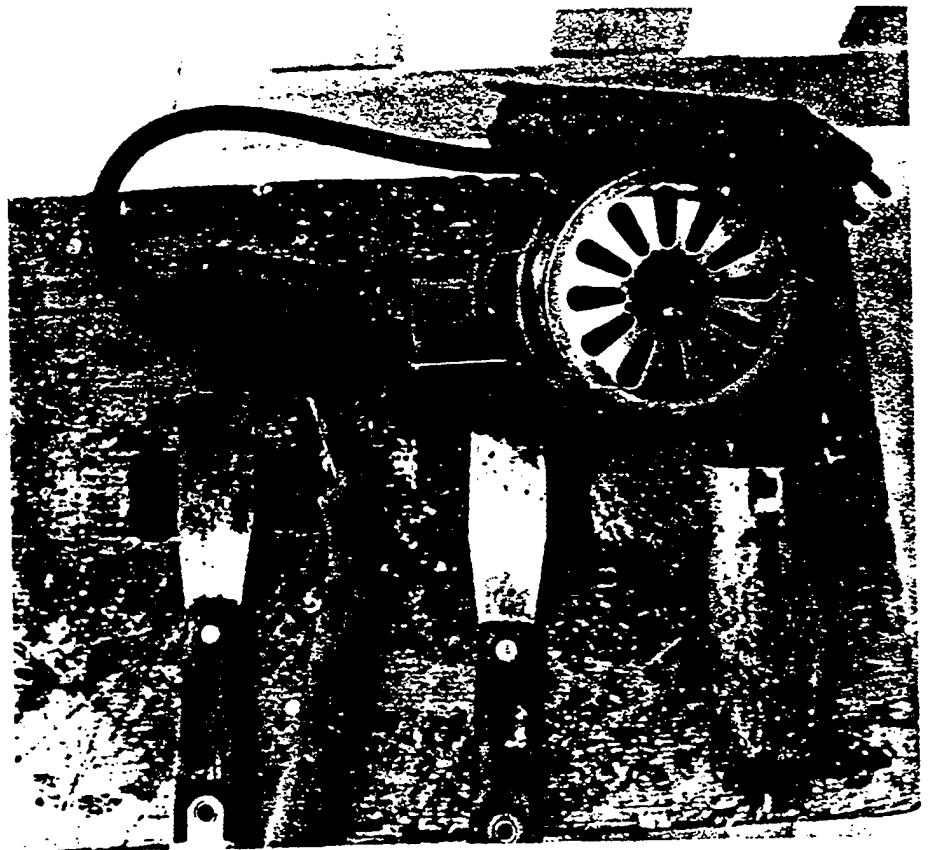

Figure 3. Heat guns, putty knives with corners rounded, and paint scrapers were used in paint removal. Photo: Michael Lee

Special care was taken in the removal of paint from decorative millwork. Scorching of decorative wood trim can occur easily, especially if the heat gun is trained on the same area too long in an attempt to remove all the irregular paint build-up. The heat gun was set at the lowest temperature and adjusted higher as necessary to compensate for the thickness and condition of the paint.

During paint removal the scraped paint tended to adhere to the putty knife, slowing the paint removal process. The workers tried several putty knives and scrapers, but none was successful in shedding the paint residue from the blade. Therefore, the knives had to be periodically cleaned of gummed paint with another putty knife. For siding, a 2 to 2½ inch-wide rigid putty knife worked best. Narrower blades were used for millwork and tight spots. To reduce chances of the workers gouging the wood with the putty knives, the edges of the blades were rounded using a grinder.

The workers used two techniques for thermal paint removal with equal success. In the first case, one

worker alternately heated and scraped the surface. Time was lost in this method because the heat gun had to be set down periodically in order for the worker to clean his putty knife. The second technique, developed by the contractor's site supervisor, was to fasten two heat guns together side by side using metal bars bolted to each gun base (see figure 4). In this way one worker heated the surface while another scraped in a continuous process. This method worked very well for expansive areas of siding and attained an average rate of 8 to 10 square feet per crew hour. On siding in tight areas where one worker operated a single heat gun, paint was removed at a rate of approximately 4 square feet per crew hour (see figure 5).

The siding was inspected for rot and cracks, and suspect sections were marked for repair or replacement. The marked sections were passed over in the paint removal process.

Fire Safety

Thermally removing paint using a heat gun does carry certain fire

risks that require precautions both in the planning as well as in the execution of the work. With an ignition temperature of approximately 200-250° F, the wood itself can ignite from the hot air blast, leading to potentially serious fire damage to the historic building.

In assessing the risk of the wood igniting, a number of factors need to be taken into account. The moisture level of the wood definitely affects the temperature at which the wood ignites. Wall studs behind the siding that are adjacent to high temperature heating pipes would be very dry compared to the siding. If the heat from the gun did not dissipate fast enough within the wall cavity, studs or deadening boards could begin to smolder in particularly hot spots or areas of very dried wood, even though the siding is not immediately affected. And where there is insulation in the wall, heat build-up would be greater, thereby increasing the fire risks. Even the daytime temperature and prevailing breezes need to be considered, since cooler temperatures and a mild breeze will help cool the siding faster. On the other hand, strong winds will make it more difficult to remove the paint, increasing fire risks in a variety of ways.

Another factor to be considered is the surface condition of the siding. Very rough edges are more susceptible to ignition than smooth surfaces. A more common problem that must be taken into account not

only in planning but throughout the work is the tendency of the laborers to get impatient or careless, directing the heat gun in one spot too long or adjusting the heat gun to a higher temperature.

In addition to the possibility of igniting the wood, there is the even greater risk of ignition of flammable debris commonly found in wall cavities and behind cornices. Debris such as bird and rat nests, builder's trash, accumulated dust and building material waste can all be more flammable than the wood siding. Examining selective areas of the wall cavity and cornices prior to selecting a paint removal method can help to establish the extent of potential fire risk from debris and building material.

Additional precautions need to be taken in the course of work. Both the work crew and park staff at the Truman home were thoroughly familiarized with the fire risks involved. Besides using scrapers or chemical strippers in the areas of highest risk, workers were instructed to avoid overheating the wood. This tends to occur at uneven wood surfaces, such as found in decorative trim or in cornices. Since workers tend to get overly confident and very casual as the job proceeds, someone on the crew should be assigned responsibility as the "fire-safety inspector."

Suitable fire-fighting equipment should be readily available. At the Truman home, carbon dioxide and water fire extinguishers were within



Figure 5. Using scaffolding, workers remove the paint with heat guns. Cracked or deteriorated siding was repaired or replaced. Photo: Alan O'Bright

immediate reach of every work tion where a heat gun was being used. The contractor added glycol to the water extinguishers during cold weather work to prevent freezing. In addition, a long garden hose was kept near the work site during warm weather.

Since debris and wood will tend to smolder for a number of hours before breaking out into flames, the building should be equipped, if possible, with a temporary fire detection system in the attic eaves and adjacent to exterior walls. Furthermore, paint removal using heat guns should stop at least several hours prior to the site being vacated each evening, to increase chances of early detection of any smoldering fire. The area of the day's work must be carefully inspected. And finally, if there is a night watchman, extra diligence should be demanded during the weeks when paint removal is occurring.

Health and Safety Considerations

Since most of the pre-1950s paint used on house exteriors is

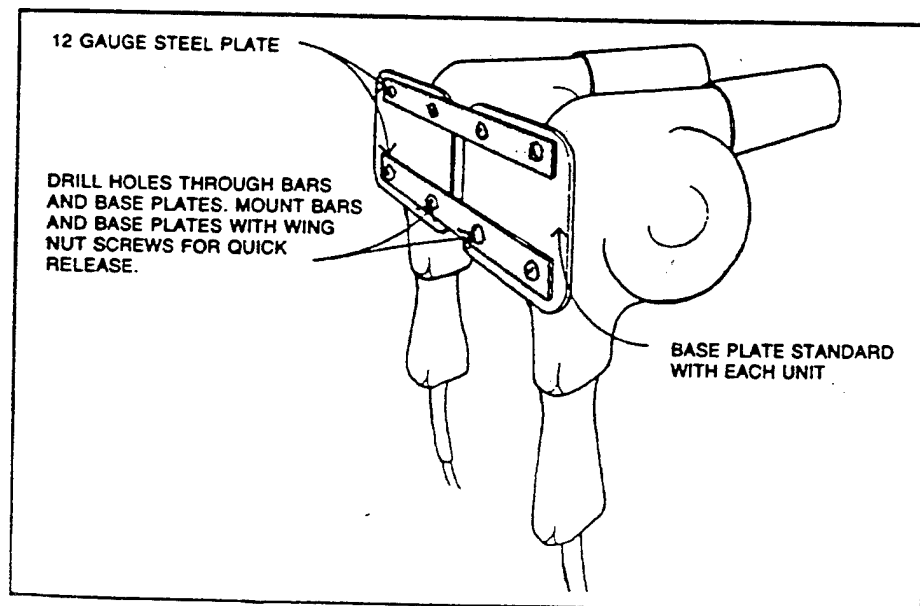

Figure 4. Method used to join two heat guns for simultaneous use. Drawing: Alan O'Bright

lead-based, additional special precautions are necessary in removing such paint. When thermally removing paint, workers should use respirators approved by the National Institute for Occupational Safety and Health (NIOSH) that have cartridges specially designed to filter lead. For projects as large as the Truman home, replacement filters available at the site are recommended to permit the necessary frequent changes of filters without interrupting the work schedule. Workers should wear separate clothing for paint stripping and provide for full leg and arm protection. An industrial vacuum cleaner placed outdoors permits periodic cleaning of clothes and the work area.

Additional time should be provided for workers to clean up properly before eating, and no eating should take place within the work area.

As at the Truman home, large plastic drop sheets should be used to collect the paint chips and prevent the lead-based paint from being deposited in the soil. Collected each day, paint chips need to be safely stored for disposition in accordance with the local and state health boards' guidelines for toxic waste.

To keep the inside of the building from being exposed to toxic vapors when removing exterior paint, it is necessary to close all doors and windows and to turn off intake fans. Workers should not be permitted to walk into the building wearing contaminated clothes. They must also wash their clothes separately from the rest of their laundry. As a final precaution, the work area should be closed to all but essential personnel, but in any event, caution must be exercised to prevent small children, pregnant women and people in ill health from entering the site.

Evaluation

Areas on the Truman home where paint was removed with the heat guns and then lightly sanded provided an excellent painting surface (see figure 6). By using workers experienced with thermal removal of paint, very few scraper tool marks were left that were noticeable. The new paint bonded well to the wood

and should perform well for about 7 years before repainting is necessary.

Proper planning and an awareness of safety concerns were important to the successful removal of paint from the Truman home. It cannot be overemphasized that anyone considering exterior paint removal using heat guns should thoroughly evaluate the structure for susceptibility to ignition under a hot air blast. Where thermal removal of paint is the selected method, fire prevention and health safety measures should be stressed emphatically to workers throughout the project.

Removal of paint using a heat gun is slower than utilizing a propane torch because the temperature of the gun is only half that of the torch flame which can reach as high as 1500° F. Use of an open flame is strongly discouraged because of the far greater fire risks involved as a result of the higher temperature. Such intense and concentrated heat not only compounds the existing fire risks already identified with the heat gun but also presents additional ones. For example, nails in the siding may conduct concentrated flame heat, thereby causing deadening boards, wall cavity debris or untreated cellulose insulation to ignite. In addition to the unacceptable fire risks with the propane torch, use of an open flame inevitably scorches the wood surface considerably—damage that is totally unnecessary.

Even with heat guns, however, scorching and tool mark damage may result. Patience is required; working too fast can be counterproductive, causing damage to the

wood surface and heightening the fire risks. The hot air blast from the heat gun will soften the paint by raising the latent oils. If a worker is impatient and either works too large an area or gets the paint too hot before it is scraped, the oils will be driven off and the paint will harden again. If this occurs, continued application of heat will not soften the paint again, instead it will eventually ignite.

Inexperienced laborers should be taught the mechanics of using heat guns on non-significant woodwork, perhaps even on another building, prior to work on a significant historic structure. Workers need to be familiar with different scraper sizes and the range of flexibility in scraper blades and putty knives. They should also know how to grind scrapers to match molding profiles in the wood work, know the appropriate angles in which scrapers should be set and used, and how to round the edges of knives and scrapers to avoid gouging the wood. Once rudimentary skills are learned, a worker should then begin on a simple, easily accessible portion of the structure to build confidence in this technique.

Regardless of the skill level of the workers, test patches should always be undertaken. Approved test patches thus serve as the standard of workmanship for the entire project and the basis for acceptance or rejection of the work. If after careful planning and examination of the test patches there is any doubt as to the ability of a structure or portions thereof to withstand thermal removal of paint, then alternative means should be considered.

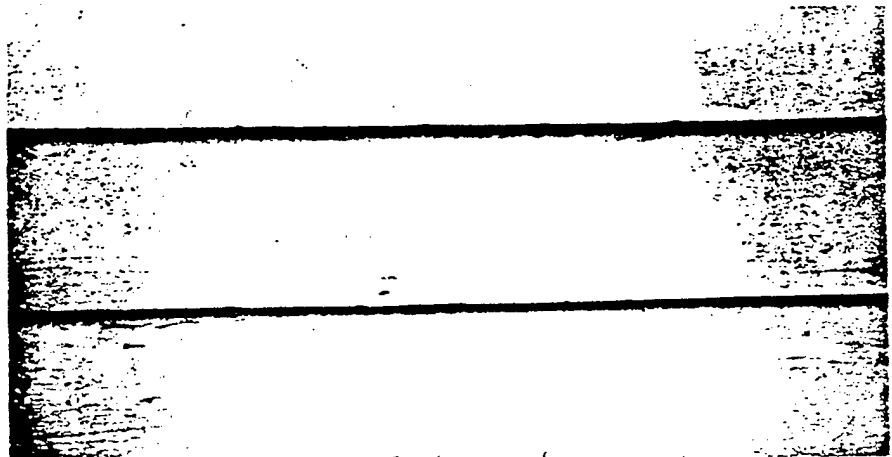

Figure 6. A typical section of the finish painted siding shows that little damage was done in removing the paint. Photo: Michael Lee

PROJECT DATA:

Building:

Harry S. Truman National Historic Site
Independence, Missouri

Owner:

National Park Service
Harry S. Truman National Historic Site
Independence, Missouri

Project Dates:

October 1984-November 1985

Project Staff:

Midwest Regional Office
National Park Service
Omaha, Nebraska

Alan O'Bright
Project Architect

Michael Lee
Preservation Specialist

Lee Jameson
Preservation Specialist

Skip Brooks
Facility Manager
Harry S. Truman National Historic Site
Independence, Missouri

Contractor:

Campos Construction Company
Ernest Callaway
Contractor's Site Superintendent
Omaha, Nebraska

Project Costs:

For paint removal using heat guns on 5,800 square feet of siding and 1,000 square feet of porch deck labor costs averaged \$4.00 per square foot. For the 2450 square feet of decorative millwork, the labor costs averaged about \$5.50 per square foot. Total investment in paint removal equipment including heat guns, putty knives, extension cords, and lights was approximately \$950. In addition there were substantial costs for temporary electrical outlets and scaffolding. The total cost for paint removal by heat gun, scraping and sanding, and chemicals from all surfaces including siding, millwork, 74 window sash, 7 door openings, 200 brackets, porch ceiling, soffits, and fasciae was about \$57,000. The above figures do not include contractor's overhead and profit.

This PRESERVATION TECH NOTE was prepared by the National Park Service. Charles E. Fisher, Preservation Assistance Division, National Park Service, serves as Technical Coordinator for the PRESERVATION TECH NOTES. Special thanks go to Don Wilson, Ernest Callaway, and the work crew of Campos Construction for providing cost and technical information; Michael Lee for his technical assistance; and Harry S. Truman NHS Superintendent Norm Reigle and his staff for their input and patience throughout the project. Thanks also go to Hugh Miller and Randy Biallas, Park Historic Architecture Division, National Park Service; to Susan LeVan, Forest Products Laboratory, U.S. Department of Agriculture; and to Philip Marshall, Architectural Artisanry Program, Swain School of Design, for their comments and assistance in the preparation of this Tech Note. The following Preservation Assistance Division staff contributed to its production: Theresa L. Robinson, Brenda Siler and Michael Auer. Cover Photo: Al O'Bright.

PRESERVATION TECH NOTES are designed to provide practical information on practices and innovative techniques for successfully maintaining and preserving cultural resources. All techniques and practices described herein conform to established National Park Service policies, procedures, and standards. This Tech Note was prepared pursuant to the National Historic Preservation Act Amendments of 1980 which directs the Secretary of the Interior to develop and make available to government agencies and individuals information concerning professional methods and techniques for the preservation of historic properties.

Comments on the usefulness of this information are welcomed and should be addressed to PRESERVATION TECH NOTES, Preservation Assistance Division-424, National Park Service, P.O. Box 37127, Washington, D.C. 20013-7127.

Tech Notes

NATIONAL PARK SERVICE
U.S. DEPARTMENT OF INTERIOR
WASHINGTON, D.C.

TEMPORARY
PROTECTION

NUMBER 1



VILLARD HOUSES

New York, New York

The original residences known as the Villard Houses were designed by the firm of McKim, Mead and White and constructed in the 1880s in the style of a Neo-Italian Renaissance palazzo. The interiors of the buildings contain a remarkably high quality of design and workmanship with extensive use of decorative paintings, mosaics, paneling and marble. The elegant interior staircases which contribute to the richness of the interior spaces were constructed in a variety of designs and materials (*see figure 1*).

In the late 1970s, the Villard Houses were adapted to serve as function rooms for an adjacent hotel while portions were retained for use as existing offices. As part of the project, a system was designed for fitting the staircases with temporary protective coverings to avoid damage while still allowing for their use in the course of the extensive renovation work.

Problem

Historic staircases were rarely designed to take the abuse which occurs during major renovation work. Even when trash chutes and material hoists are located through windows, staircases are still subjected to dirt and heavy wear during construction work, and

the risk remains of incurring costly or irreparable damage. Stairwall materials such as marble, wood wainscoting and Lincrusta wall covering, as well as balustrades and stair treads, are particularly vulnerable to damage. Where there are tight turns and narrow staircases, the risks of damage are even greater. Closing off the stairs usually is not practical either because the stairs are needed for daily use during construction or must be kept open for job safety.

In most instances, the best preservation approach and the one that often proves economical in the long run is to provide sound and effective protection of the staircase *in situ*. The project architect should be the one to design a protection system for the staircase.

In designing the protective system, care should be taken to protect the walls, the balustrade, and the staircase itself. With the Villard Houses, a simple, practical and effective system was developed to protect the staircases during the renovation work. The wide range of staircase designs, decoration, and finish work found in the Villard Houses furnished ample opportunity to test the broad applicability of this protective system. It is described in the following sections, with some liberty taken in making minor refinements for the benefit of others wishing to use it.

Temporary Protection of
Historic Stairways during
Rehabilitation Work

Charles E. Fisher
Preservation Assistance Division
National Park Service

Significant interior features in historic buildings should be protected during construction work.

Solution

The basic system consisted of using plywood and padding to cover the walls, steps and balustrade without using any anchoring devices that would damage historic material (see figure 2). Screws were used rather than nails in fastening the wooden temporary pieces together to lessen the chances of accidental damage to historic fabric and to facilitate disassembly.

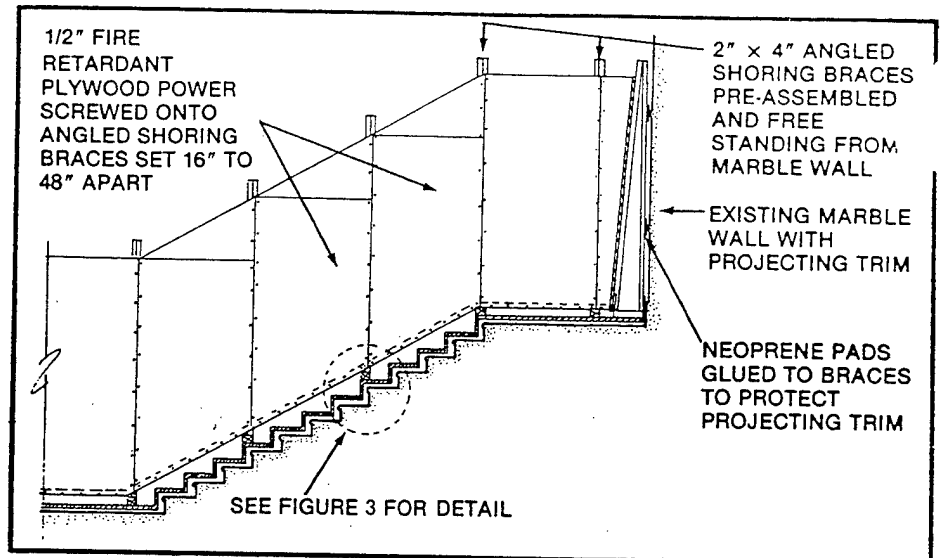

Figure 1. The Villard Houses include stairways ranging from very elegant (seen here) to quite simple. All could have been damaged if not protected during the extensive rehabilitation work. Photo: Steven Zane, HABS Collection.



Figure 2. A system for protecting the decorative staircases was drawn and specified by the project architect. Drawing: Christina Henry.

Stairsteps

Both the marble and the wooden stairsteps were identified in the planning stage as being vulnerable to damage and excessive wear during the renovation work. The decision was made to lay a temporary wooden covering over the existing stairs in a manner which would provide for maximum protection of the historic fabric without hindering daily use of the stairs by the construction crew (see figure 3). A sheet of soft fiberboard served as a cushion between the wooden covering and the historic stairsteps. The fiberboards extended approximately one inch past the existing treads to provide better protection for the delicate nosing. For each step, a second piece of fiberboard was cut to rest against the riser. The temporary wooden treads applied over the fiberboard were cut out of plywood rather than planking, since plywood has a greater resistance to cracking and curling in such wide widths. For the risers, less expensive planking sufficed. In both cases, fire retardant wood was specified.

In assembling the temporary steps, power-driven screws of specified length were used. Screws rather than nails were chosen in order to avoid pounding damage to the masonry joints and the relatively thin historic marble panels used in the staircase construction, and also to reduce the chances of damage during disassembly.

Wooden stops measuring one inch square were first screwed onto the end of the plywood treads; the plywood set onto and against the two fiberboards used on each step; and then the planking used for the risers was set in and secured in place with screws. For disassembly, the process was reversed.

Balustrade

Once the temporary wood floors were installed, the balustrades were encased in plywood (see figure 4). For the sections running on top of the handrail, 5/8" or 3/4" plywood was used, cut wider than the handrail to permit attachment of 2 by 4 blocking on the underside for securing the 1/2" plywood side walls away from the balustrade (see figure 5). For padding, neoprene was glued to the face of the blocking closest to the edge of the handrail as a cushion in case the covering was jarred. The handrail was cushioned further by soft fiberboard glued to the underside of the plywood top. After the top section was assembled, the side plywood walls were cut and attached; the side walls were additionally blocked out wherever the newel posts protruded beyond the balustrade (figure 6). The entire assemblage was secured tightly with judicious use of braces and blocking or where necessary was screwed to the temporary wood floor.

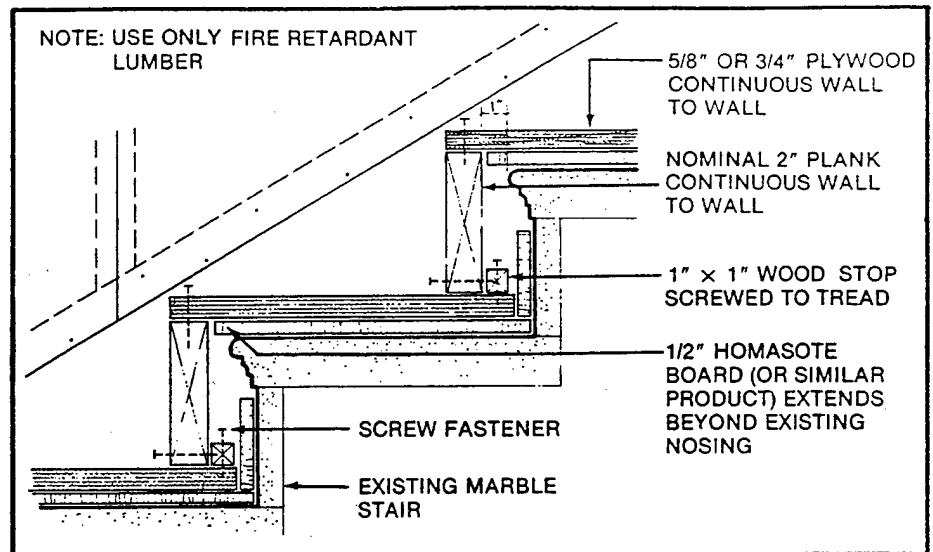

Figure 3. The plywood treads extended past the nosing on the historic steps with soft fiberboard set in place beforehand as additional protection. Drawing: Christina Henry.

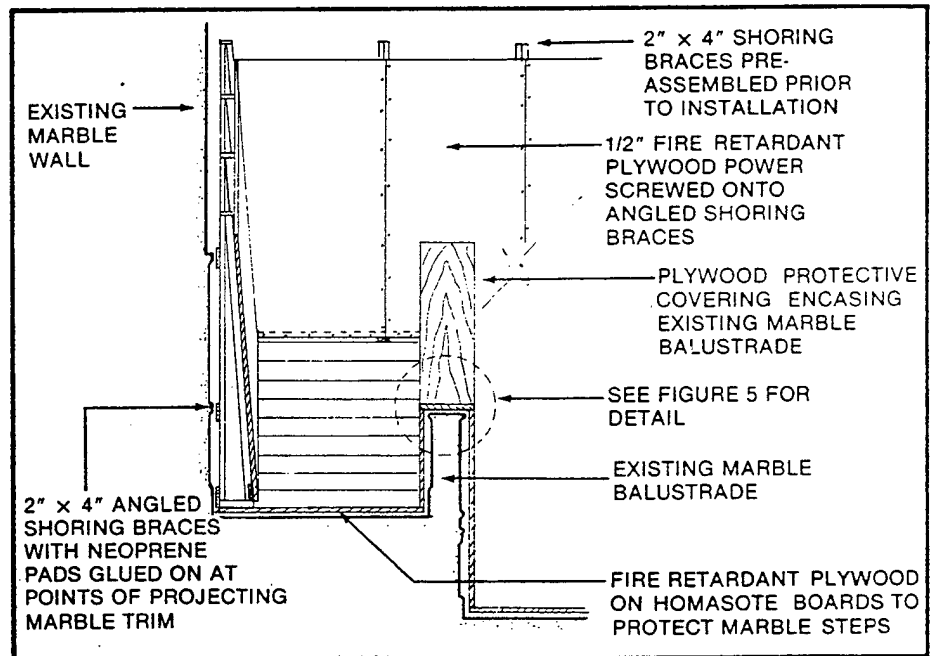

Figure 4. This cross-section of one of the staircases shows that the entire historic balustrade was temporarily encased in wood during the renovation work. Drawing: Christina Henry.

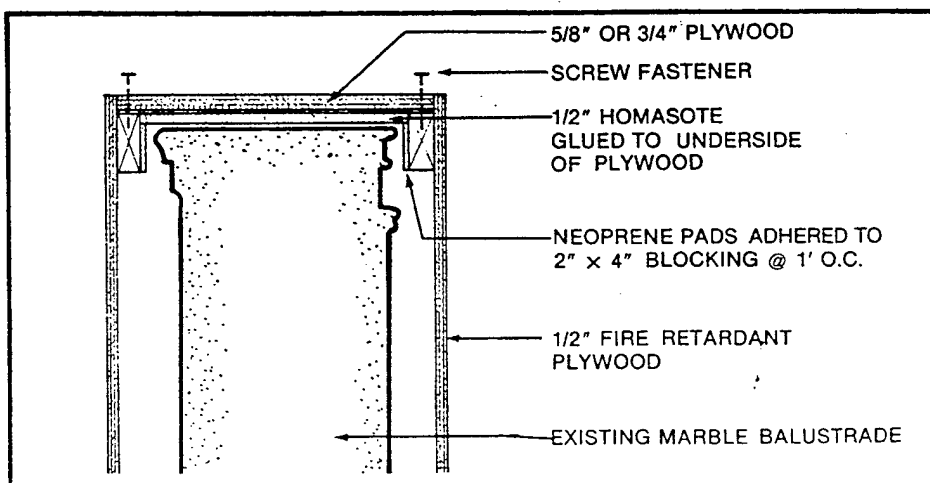
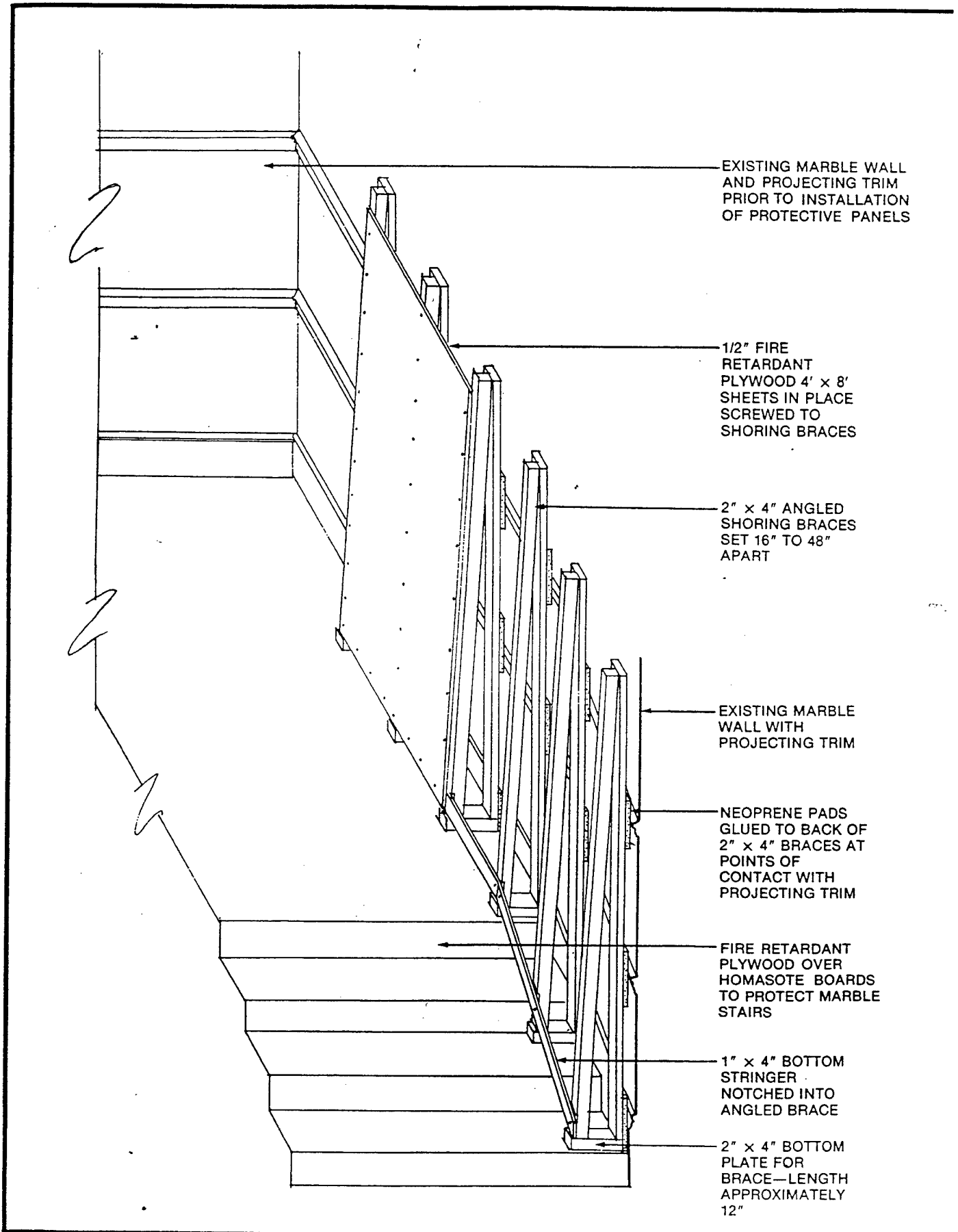

Figure 5. As with the step detailing, the temporary protection over the balustrade and hand railing used plywood padding, blocking, and screw fasteners to minimize possible damage. Drawing: Christina Henry.



4 Figure 7. The temporary wall covering going up the stairs consisted of plywood mounted on a wooden frame. Neoprene padding was used where the frame abutted the historic walls. The method shown here requires no fasteners to be used, avoiding possible damage to the decorative walls. Drawing: Sharon Park, A.I.A.

Stairwalls

A temporary eight foot high wall was constructed to protect the historic wood paneling, marble and decorative trim typically found along the stairs. The wall covering consisted of plywood attached to a wood frame that had been designed so as to require no anchor attachments to the historic walls (see figure 7). The triangular shaped sections of the frame which supported the plywood rested on the plywood floor covering. Wherever the frame abutted historic material, a thin neoprene pad was glued to the wood beforehand to avoid scratching. For greater rigidity, 2 by 4 sleepers were added in various locations to connect the triangular sections of the frame. In cases where the historic handrail protruded considerably and was not temporarily removed during construction, the triangular sections were not pre-assembled, but rather constructed in place around the railing.

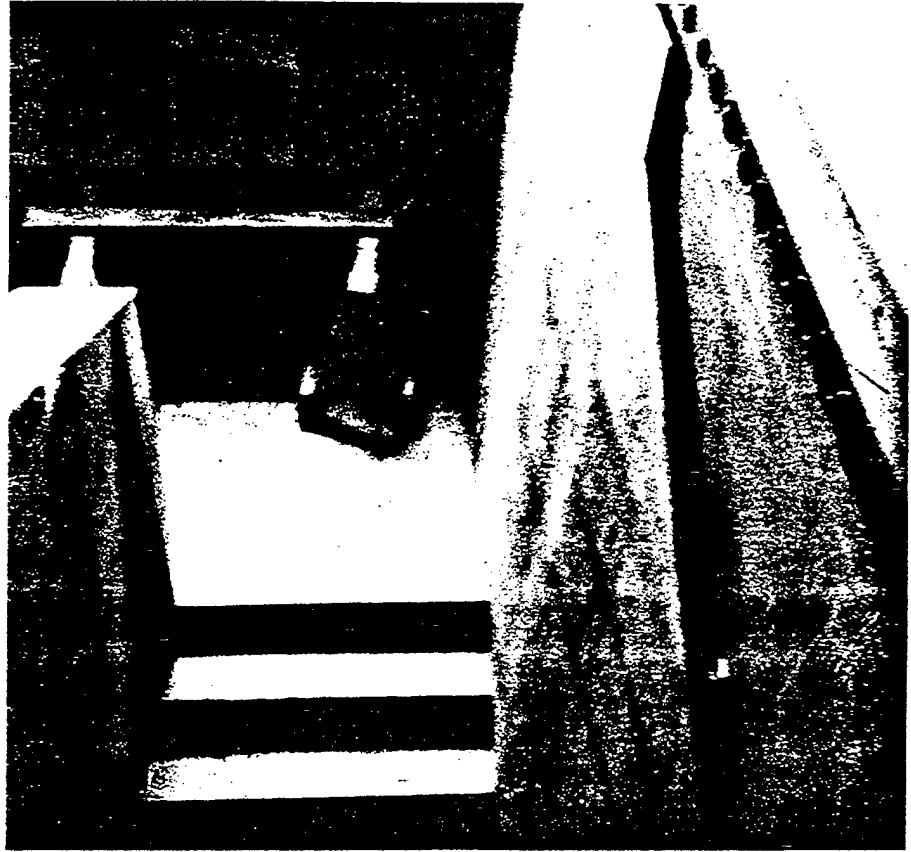

Figure 6. The balustrade on the left side of the photograph has been entirely encased in plywood to protect it from damage. Note that the kick-out at the end is due to the protrusion of the newel post. Photo: Charles Fisher.



Evaluation

The cost of this work was quite modest and the protective system was sufficiently flexible to be adapted to staircases of different dimensions, designs and material. It was easy to construct and required only common fasteners and materials. Most importantly, this system effectively protected the staircases against damage during the renovation work (see figure 8).

Figure 8. The entire historic staircase has been protected against possible damage during the renovation work. The balustrade on the left has been encased in plywood; the floors have been covered; and a temporary plywood wall constructed, shown on the right and at the landing. Note that the plywood wraps around the wall at the entranceway. Photo: Charles Fisher.

PROJECT DATA:**Building:**

Villard Houses
New York, New York

Developer:

The Palace Company
Helmsley-Spear, Inc.
New York, New York

Project Date: 1977-1980**Architect:**

Emery Roth and Sons, P.C.
845 Third Avenue
New York, New York

Project Cost:

The cost of the overall rehabilitation work was approximately \$10,000,000; cost for the temporary stair covering was too small to be broken out in the construction cost.

This PRESERVATION TECH NOTE was prepared by the National Park Service. Charles E. Fisher, Preservation Assistance Division, National Park Service, serves as Technical Coordinator for the PRESERVATION TECH NOTES. Information on the staircase protection system was supplied by the architects for the project, Emery Roth and Sons, P.C. of New York City. Drawings appearing in figures 2, 3, 4 and 5 were redrawn by National Park Service staff based on material originally prepared by the architects. Special thanks go to the following Preservation Assistance Division staff who contributed to the production: Michael J. Auer, Christina Henry, Brenda Johnson, Sharon Park, Martha A. Gutrick, Terry Robinson and Janet Thomas.
Cover photo: HABS Collection.

PRESERVATION TECH NOTES are designed to provide practical information on innovative techniques and practices for successfully maintaining and preserving cultural resources.

All techniques and practices described herein conform to established National Park Service policies, procedures, and standards. This Tech Note was prepared pursuant to the National Historic Preservation Act Amendments of 1980 which direct the Secretary of the Interior to develop and make available to government agencies and individuals information concerning professional methods and techniques for the preservation of historic properties.

Comments on the usefulness of this information are welcomed and should be addressed to Tech Notes, Preservation Assistance Division, National Park Service, P.O. Box 37127, Washington, D.C. 20013-7127. This publication is not copyrighted and can be reproduced without penalty. Normal procedures for credit to the author and the National Park Service are appreciated.



PRESERVATION Tech Notes



U.S. Department of the Interior
National Park Service
Cultural Resources

Preservation Assistance Division

TEMPORARY PROTECTION NUMBER 2

Specifying Temporary Protection of Historic Interiors During Construction and Repair

Dale H. Frens, AIA
Frens and Frens

PLANNING AND SPECIFYING TEMPORARY PROTECTION

Projects involving historic interiors range from the meticulous restoration of a National Historic Landmark residence as a museum to the insertion of modern apartment units in an abandoned loft building. The size of the building, significance of the interiors, and scope of work will determine how best to protect interior finishes, features, and collections during construction work. All work involving historic buildings, however, shares the need to properly plan for and specify appropriate temporary protection measures. Without such provisions, unnecessary damage can result which will require additional

funds to correct or which can lead to irreversible loss of historic fabric.

Problem

Relying on the contractor to protect interiors without specifying such protection puts historic material and finishes at unnecessary risk. Protective measures must be specified in the construction specifications for the job.

Although general contract language may make reference to "protecting existing construction" and may require that the contractor "restore any damage to its original condition at no additional cost to the

Historic interiors and collections should be protected from potential damage during construction work

owner" (or other similar language), in practice, the general nature of the language affords little *protection* to existing historic finishes or features. At best, such measures may provide a mechanism for repairing and paying for damage *after* it has occurred. Rather than provide adequate protection, some contractors deliberately elect to repair damage, believing it is cheaper.

Solution

The planning process includes three important goals: 1) protection of any collections where present; 2) fire protection; and, 3) protection of historic architectural features and finishes. Collections safety during construction applies to buildings in which collections are stored or displayed, including cases where there are historic furnishings that are not part of a formal collection. Construction operations pose a serious threat to collections, and it is nearly always desirable for the collection to be removed from the work area. While this may seem obvious, in practice, maintenance and repair activities often take place in spaces containing collections. Common examples of this include the installation of wiring for security systems, electrical upgrades, or telecommunications; repainting; and additional work undertaken after owner occupancy.

Except for the most minor repairs, as defined by the curator of collections for the institution or other responsible parties, collections should be moved out of the construction areas to a secured and safe location until *all* work has been completed. For small buildings where extensive work is taking place, the collection should be entirely moved off site to another location. This approach may also be desirable for larger buildings, depending upon the nature of the work, risks to collections, and availability of protected space on site.

Fire Protection

Fire poses the greatest risk of sudden catastrophic loss during construction activities in existing buildings. Just one of numerous examples is the 1985 Harrison Court fire in Philadelphia, in which a block-long National Register warehouse building undergoing rehabilitation burned to the ground (*see cover photo*). The fire was caused by sparks from cutting torches that were being used during selective interior demolition work.

To address the threat of loss of life and property during construction operations, the National Fire Protection Association (NFPA) publishes NFPA 241: *Safeguarding Building Construction and Demolition Operations*, most recently reissued in 1989¹. Although written to provide fire protection procedures for all types of building con-



Figure 1. The spontaneous combustion of cloth rags that had been used in applying a common finishing wax caused over \$1 million damage to a historic government office building in 1991. Remains of the trash can where the rags had been stored overnight is indicated by the fireman's notepad. After the cause of the fire was determined, a standard specification provision was developed for future contracts requiring the contractor to remove all material contaminated with finishing products from the site at the end of the day.

struction activities, including new construction, NFPA 241 should be a reference standard in any selective demolition specification, and a foundation for addressing fire safety on building rehabilitation sites. Additional guidance is available in NFPA 914: *Rehabilitation and Adaptive Reuse of Historic Structures*. When these are utilized as reference standards, the historic building owner should obtain and enforce their recommendations (*see figure 1*).

The building owner and design professional should also review fire protection measures and fire fighting methods that are permitted by the standard but may be insensitive to the protection of historic finishes. Such measures and procedures should be clearly stated as "prohibited" in the specifications or construction agreement.

According to NFPA, 60% of the fire losses to buildings under construction were caused by the following: 1) portable heating equipment (25%); 2) cutting, welding, and plumbers' torches (20%); and, 3) matches and smoking (15%).

In addition to these three causes cited by NFPA, for historic buildings there is a fourth major cause—the use of heat devices to remove paint. They share a common characteristic: they are all caused by contractor operations on the site. For these reasons, full adherence to the project specifications is needed to reduce, or eliminate, these causes of fire.

Temporary Heat

During the normal operation of a building, the heating plant—boiler or warm air furnace—is placed at a remote location (usually in a fire-rated room); set in a stationary position; equipped with a fresh air supply and non-combustible exhaust flue; and supplied with fuel piped from a remote oil tank or by a natural gas pipe brought into the building. In the case of construction projects involving historic buildings, temporary heating devices are frequently utilized. These devices are inherently dangerous because they are portable and often unstable; have movable and nearby fuel tanks; and often exhaust into the space being heated.

Electric temporary heaters are considered the safest temporary heating devices, but require heavy conductors and power supplies which are not always available at desired locations when temporary heat is needed. As a result, these are generally not used. One alternative is a propane heater, which is safer and cleaner in operation than the oil-fired temporary heating unit, and has greater output and portability than the electric heater. Oil-fired temporary heaters should be avoided unless they can be vented directly to the building exterior, or be placed in a completely open space of a building that is of non-combustible construction.

Cutting, Welding, and Plumbers' Torches

The second most important cause of fire during construction operations is the use of open flame cutting, welding, and soldering equipment. Cutting and welding in existing buildings should be conducted with adequate supervision, fire watches, and emergency fire protection apparatus to assure that sparks or drops of hot metal do not start fires. Cutting and welding should be controlled by requiring a new permit each day, issued by the general contractor or construction manager, for each location where cutting or welding is to occur. A permit should not be issued until the following conditions are satisfied:

1. It has been determined that cutting and welding can be safely conducted at the desired location;
2. Combustibles have been moved away or safely covered;
3. Fire watchmen with extinguishers are posted for the duration of the work and for 30 minutes after work completion; and
4. Cutting and welding operations cease 2 hours prior to the close of construction each day to minimize the risk of undetected smoldering fire.

Permits and the inspection and maintenance of fire protection systems should be managed by a fire protection manager employed by the contractor or construction manager. (For small projects, the construction foreman may fill this role.) In addition to issuing and logging-in the cutting and welding permits, the fire protection manager should routinely inspect cutting and welding locations, all temporary heating equipment in operation, existing fire protection systems and exits, and first aid fire fighting equipment. ("First aid" fire fighting equipment refers to fire extinguishers and available water sources available at the job site for providing the "first aid" in fighting a fire.) At the end of each work shift, the fire protection manager should file a written report with the construction manager or contractor and the owner. Any violations or unsafe conditions relating to fire protection should be immediately reported to the construction project manager for action, including halting unsafe operations, improving fire protection measures, and notification of the owner.

A fire watchman reporting to the fire protection manager should be stationed at each cutting or welding location. The fire watchman's responsibilities include watching the work area for falling sparks and molten metal; covering combustible materials with fire blankets and maintaining such protection; and inspecting and maintaining first aid fire fighting equip-

ment. For smaller projects, the construction fireman or other designated people should be assigned the responsibility of inspecting of each cutting and welding location frequently during the day (see figure 2).

The extent of first-aid fire fighting equipment is dependent on the size and type of building and scope of project work. At a minimum, even for restoration work in a small house museum, one or two ABC-type fire extinguishers should be placed in plain sight on each floor of the building where work is taking place. The available water supply should be located and clearly marked, maintained, and provisions made for its ready use.

For all rehabilitation projects, the provision and/or maintenance of exits is of critical importance, both for life safety of construction personnel, and for fire fighters' access to work areas. For major rehabilitation projects in large and tall buildings, the handling of exit stairways is of great importance. Existing exit stair towers should be maintained, and construction priority given to the completion of new exit stairways. Where an existing fire door requires replacement, the old door should be removed and the new door and hardware installed immediately. While perhaps not as efficient as removing all doors in one phase and installing all new doors in a second phase, replacement on a one-for-one basis ensures that no more than one fire tower door is out of operation at any time during construction.

Prior to the commencement of any major rehabilitation on the small or large historic property, the owner and construction manager or contractor should meet with the local fire marshal to plan site and building access in the event of fire. The extent of fire department coordination is dependent on the size and location of the project, the significance of the structure, and the type of hazardous operations included in the project scope. Access paths for heavy fire fighting equipment should be laid out and maintained. Free access from the street to fire hydrants and to outside connections for standpipes, sprinklers or other fire extinguishing equipment should be provided and maintained.

The third most common cause of fire during construction is smoking and matches — entirely a construction management issue. Construction specifications for rehabilitation work should always prohibit smoking within the building, and enforcement of the prohibition is a priority responsibility of the contractor or construction manager.

A fourth cause of fire in historic buildings is the use of heating devices to remove paint. Due to the high fire risks, the use of open flame devices to remove paint should



Figure 2. Because of the fire risks, open flame cutting and welding deserves careful attention both in the preparation of specifications and during the work. As much welding as possible should be done off site. For example, at the Nightingale-Brown House, several large trusses were assembled off site, then carefully hoisted through a window for installation. Photo: Irving B. Haynes and Associates.

be prohibited in the specifications. Special precautions should be delineated when allowing heat plates and especially hot air guns. In addition to the possibility of igniting the wood, there is the even greater risk of ignition of flammable debris commonly found in wall cavities and behind cornices (see *Preservation Tech Note Number 18*). Where heat devices are permitted, their use should be prohibited from cornice soffits or other similar conditions where friable combustible material may be exposed to heat through cracks and open joints. Additionally, paint removal work should stop at least two hours prior to the site being vacated each evening, to increase chances of early detection of any smoldering fire. The area of the day's work must also be carefully inspected. Construction specifications should also require that temporary fire detection devices be installed in close proximity to the specific work area and that the alarm system be directly monitored.

Protection of Historic Interior Features and Finishes

An important difference between protecting historic interior features and finishes and protecting new interior features and finishes during construction is in the timing of the construction schedule. In new work, important and fragile casework and finishes are installed late in the construction schedule, after mechanical and electrical

systems and other high impact work are completed, thus not exposing the finishes to major construction operations. In preservation work, however, existing interior finishes are exposed to all the high impact and potentially damaging construction phases of the project, except to the extent that such finishes are temporarily protected or separated from construction work.

Important architectural features which are easily removed should be stored off site, if possible, to protect them from vandalism, theft and damage during construction. Lighting fixtures, fireplace mantels, and interior doors are typical examples. Less movable architectural material or finishes such as wallpaper are often best retained in place but may require custom-designed protective measures developed and monitored by a conservator (see figure 3).

Access by construction personnel to spaces with significant features and finishes should be restricted, except for their work relating directly to the preservation

of such spaces. Spaces with restricted access should be identified by the planning team and indicated in the construction documents in order to allow the contractor to include any associated costs in his price proposal (see figure 4).

For spaces such as halls and lobbies, it may not be practicable to limit access, and for all interior spaces, some construction work may be required. In such circumstances, interior finishes must be physically isolated from construction operations by means of protective barriers and coverings. Such surfaces are generally limited to flooring, walls up to approximately 6 foot height, and special construction such as staircases. Only under unusual circumstances do ceilings or upper wall areas require physical protection during construction. Examples are walls with historic wallcoverings or fragile ornamental ceilings that are at risk to physical abuse or to vibration damage caused by construction activities.

Flooring should be protected from damage caused by abrasion, falling objects,

dust and dirt, and spilled liquids (see figure 5). If work in, or traffic through, a particular space does not involve one or more of these risks, temporary protection may be reduced. Damage caused by abrasion can be controlled by means of protective coverings such as canvas tarps or resilient wood fiber panels. Canvas tarps should overlap and be taped at all joints. Resilient wood fiber panels should be carefully fitted with tight seams and laid continuously wall to wall. Joints should be taped to avoid displacement of the panels after setting. For added safety, resilient panels left exposed should also be fire-retardant treated to achieve a UL Class A listing for flame spread and smoke developed. Such a readily available product is N.C.F.R Homasote.

For greater protection from physical force, a layer of plywood can be applied over the Homasote panel underlayment, with joints staggered to stabilize the assembly. In this double layer assembly, the top plywood should be treated with a fire-retardant, but the underlayment need

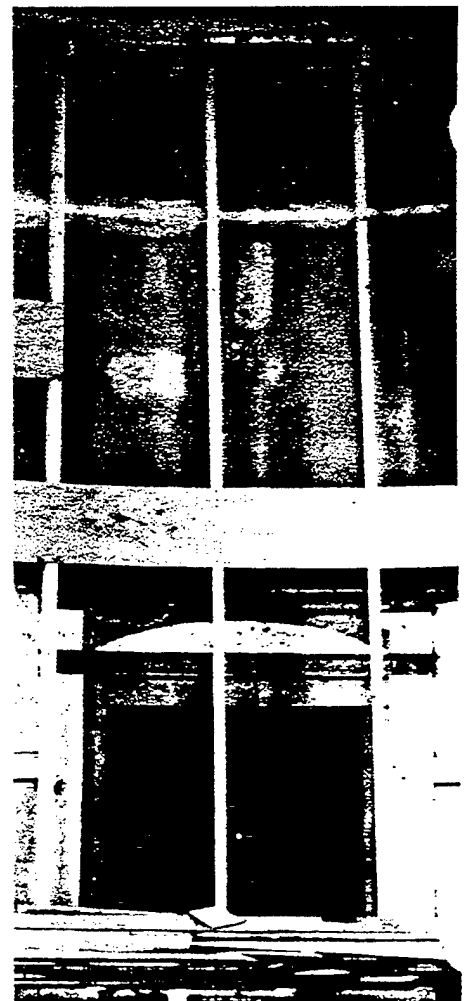
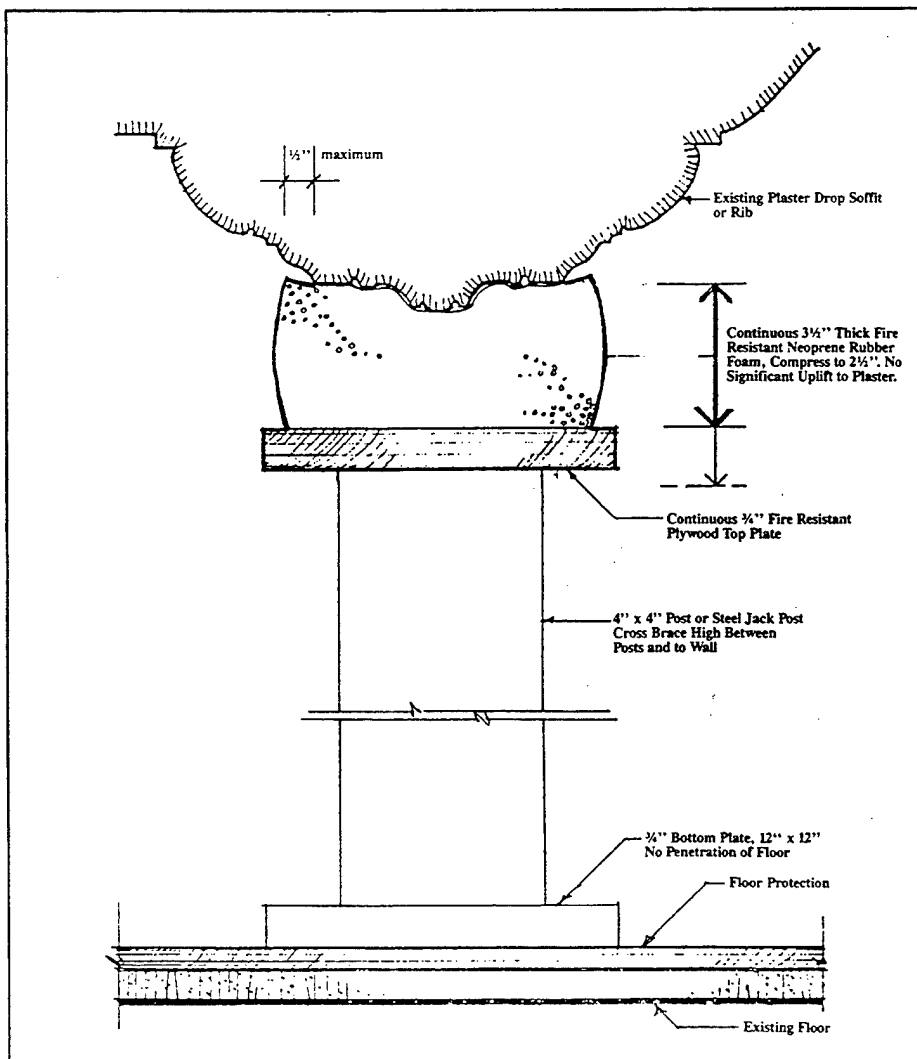

Figure 3. Vibrations generated during construction may necessitate the installation of temporary support for such fragile features as plaster ceiling cornices and soffits. Drawing: Villard Houses — courtesy of Emery Roth & Sons Architects. P.C. Photo: The Octagon, Lonnie Hovey, AIA.

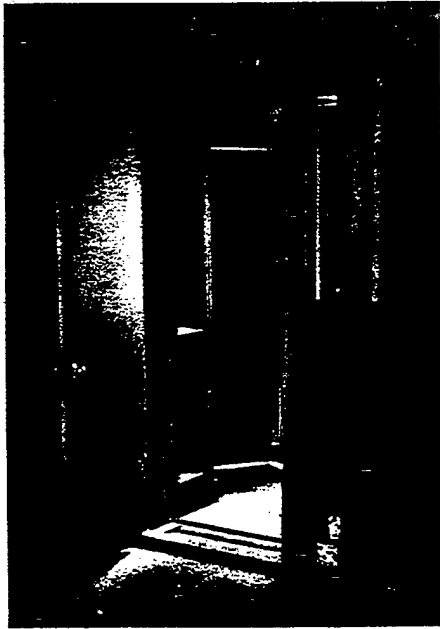

Figure 4. Temporary protection during construction can involve covering historic features, such as floors and walls, as well as using temporary doors to control the passage of workers and the inevitable dust and dirt. Prominently located fire extinguishers are mandatory. Photo: Lonnie Hovey, AIA, The Octagon.

not be. Where protection from spilled liquids is required, a layer of polyethylene sheeting should be applied between the Homasote panels and the plywood top layer. Care should be taken in planning the protection assembly to ensure that moisture from spilled liquids is not trapped against the historic flooring. Otherwise, the staining, splitting, wood-grain raising, or stone-finish destruction could potentially go undetected for months while concealed from view under the protection assembly. Care should also be taken to avoid sheet coverings such as building felt, which could potentially stain the historic flooring.

Wall protection is typically fabricated from fire-retardant treated plywood attached to wood framing. The assembly should be self-supporting and self-bracing, secured at its base to the floor protection assembly. Struts and walers need to be provided, as required, to brace the assembly without installing fasteners into the historic wall finish. Careful assembly includes using screw fasteners in order to eliminate hammering during assembly and ripping damage during disassembly. Where wood framing, furring, or panels abut historic wall materials, the back side of the

protective assembly should also be padded using strips of neoprene or strips of Homasote board, glued to the protective assembly member.

Historic stairways, balustrades, balconies, fireplaces, door surrounds, window surrounds, and other components will also need to be protected from constructive damage by combining the techniques described for floors and walls (see figure 6). Horizontal surfaces should be protected as floors, and vertical assemblies treated as walls, with the major difference being the complexity of the framing required.

Specifying Protection

Detailing and specifying temporary protection of historic interiors during construction is the responsibility of both the architect and contractor. Most general conditions of a construction contract contain language similar to *AIA Document A201, General Conditions of the Contract for Construction*: "The Contractor shall be solely responsible for and have control over construction means, methods, technique sequences and procedures and for coordinating all portions of the work." The same document in a later paragraph states, "The

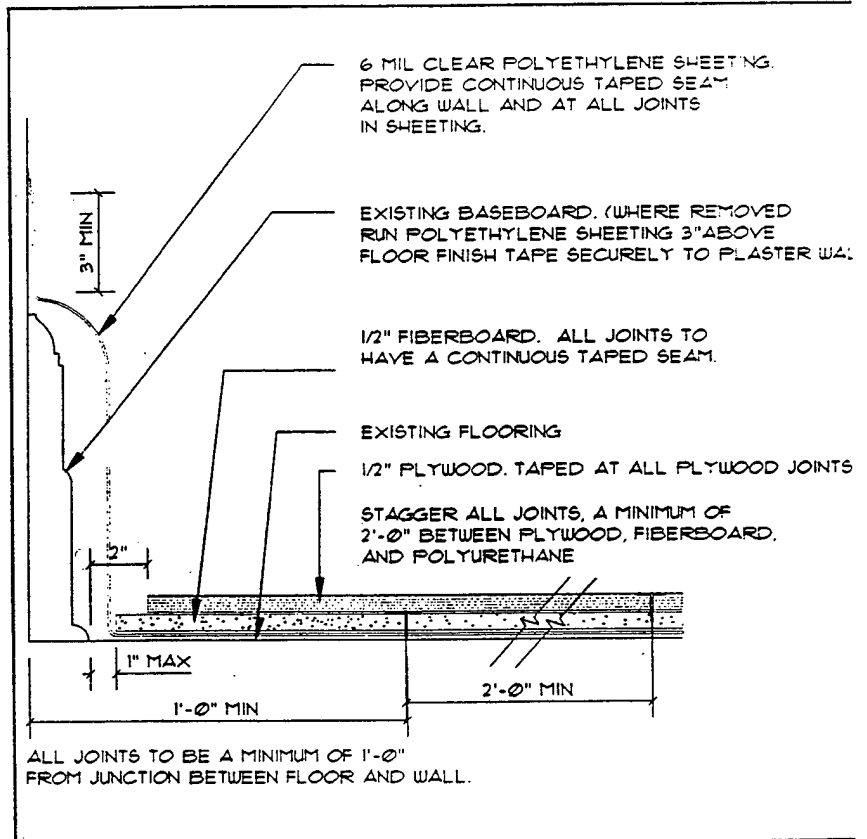

Figure 5. To provide for adequate floor protection in the New Jersey State Capitol, this area was swept clean, then covered with polyethylene sheeting to protect against spills and dirt abrasion. Fiberboard (1/2" thick) was placed over floors and the joints sealed with tape. Finally 1/2" plywood was laid with all joints taped. This floor protection system has been successful over many years of use and is recommended in major construction areas, and where tile, marble, parquet wood, or other historic flooring is involved. Photo and drawing: Ford Farewell Mills and Gatsch Architects.

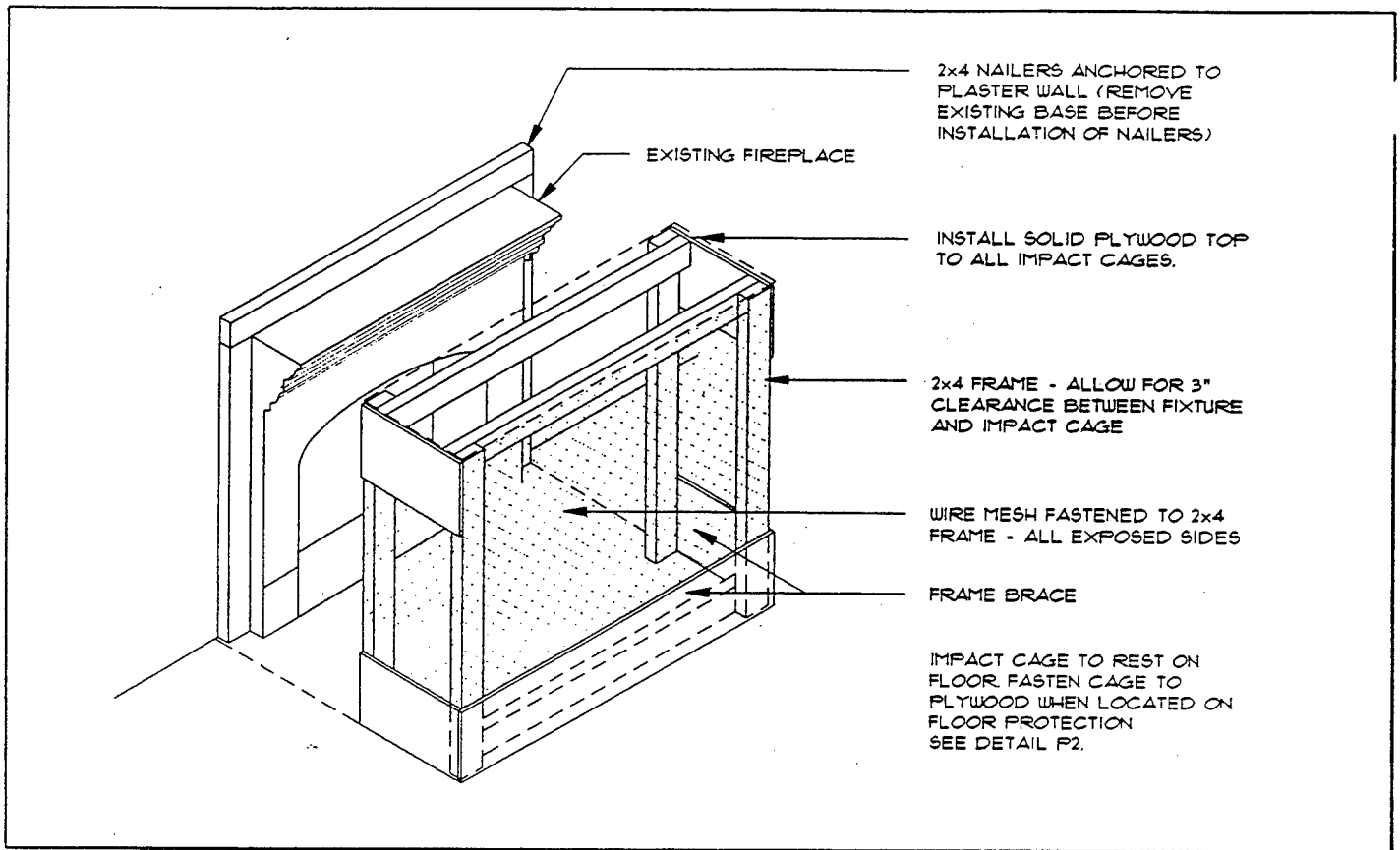

Figure 6. A self-supporting impact cage utilizing wood and wire mesh protects the fireplace. In this project, the long construction process required bidders to have visible access to features such as the fireplace. The wire mesh also facilitated monitoring during the lengthy construction. Photo and drawing: Ford Farewell Mills and Gatsch Architects.

Architect will not have control over or charge of and will not be responsible for construction means, methods, techniques, sequences or procedures, or for safety precautions and programs in connection with the work.”³ And, directly related to temporary protection, “The Contractor shall take reasonable precautions for safety of, and shall provide reasonable protection



Figure 7. A contractor's solution to protecting the limestone door surround consisted of thin foam sheeting, secured with wood nailed to the masonry. This protection was rejected as inadequate by the architect, and a full plywood enclosure constructed. In the architect's solution, it should be noted that a temporary door is used while the original door is stored for safe keeping during construction. Photo: Ford Farewell Mills and Gatsch Architects.

to prevent damage, injury, or loss to . . . other property at the site or adjacent to . . . not designated for removal, relocation, or replacement in the course of construction.”⁴ Thus, the contractor is responsible for the means and methods of construction, including protection of public and property. The courts have reinforced this concept by holding an architect liable for construction injuries where the architect took an active role in enforcing construction safety practices.

The above notwithstanding, architects routinely specify temporary facilities including temporary utilities, temporary construction and support facilities, and security and protection services. For preservation projects, it is recommended that temporary protection of historic interiors during construction be specified in a separate Division 1 specification section entitled “Special Project Procedure” or “Restoration Project Procedures” to ensure that required provisions are not overlooked by bidders because they appear in the often lengthy Section 01500 — Temporary Facilities. Under competitive bidding circumstances, bidders logically seek to minimize the cost to the project for providing temporary facilities, including temporary protection of historic interiors. By creating a separate section in a price proposal, the bidder will be inclined to treat the “special project procedures” as an added cost rather than a part of the temporary facilities required for any alteration project. The contractor's project manager can thus anticipate making reasonable expenditures for providing specified temporary protection during construction. To ensure the adequacy of temporary protection measures in projects involving a construction manager, temporary protection is often best provided by the construction manager, who normally works for the owner on a cost-plus-fee basis (see figure 7).

Temporary protection should generally be specified rather than detailed, with details provided by the contractor as shop drawings. Materials permitted and prohibited, fasteners, attachment to existing construction, descriptions of assemblies, and other provisions should be specified in adequate detail to enable the contractor to prepare shop drawings for specific field conditions. More detailed requirements may be involved where a conservator's plan is required for select items or rooms due to their special significance.

The temporary protection of historic interiors during construction is also affected by other specification sections. In Section 01045—Cutting and Patching, it should be clearly stipulated *who* is to perform cutting and patching in spaces involving historic interiors. This is particularly

important in multiple prime contracts, where each contractor is responsible for his own cutting and patching. Unless carefully specified, all the positive temporary protection work specified in Section 0110 may be lost to damage done during cutting and patching work. In Section 01500—Temporary Facilities, requirements for trash chutes affect fire protection, as do requirements for field offices, materials storage and site access. Additionally, dust control, whether specified in Section 0150 or in Section 02070—Selective Demolition, must not be permitted in historic buildings by means of water sprinkling.

Conditions prior to commencement of construction should be photographically documented by the contractor. For large preservation projects, project specification

Special Hazards Involving Large Buildings

The rehabilitation of large buildings demands the greatest planning for fire safety. Although structural components are typically noncombustible, other building assemblies, stored materials, and finishes are not. A number of special hazards are created during rehabilitation that could cause major damage to the historic building. Alterations to fire stairs and elevators may create unvented, unprotected multi-story shafts which behave as flues in the event of a fire. Alterations to fire stairs, fire separations, and fire sprinkler systems may require the deactivation or partial deactivation of such systems during construction work. Building heat and water are often turned off during major building rehabilitation, introducing the hazard of temporary heat while reducing the protection afforded by a quickly accessible water supply. And finally, the rehabilitation of major structures typically involves large construction equipment, including those powered by internal combustion engines within or immediately adjacent to the buildings.

For large, non-combustible construction structures requiring the use of internal combustion engines indoors, fuel storage, equipment operation, and equipment service should be addressed in the specifications. Except for propane fueled “bobcat” loaders, all exhausts should discharge to the building exterior. Fuel for internal combustion engines should not be stored and equipment should not be serviced within the building.

may require a professionally prepared videotape survey of the entire building interior. For small projects, a videotape survey may also be an effective supplement to existing conditions photographs. The owner may wish to document existing conditions independent of the contractor in order to avoid any future dispute regarding damage caused by construction operations as opposed to pre-existing damage.

Conclusions

Temporary protection of historic interiors during construction, an essential component of any preservation project, is largely a construction management issue. A successful protection program is the result of careful pre-planning, thorough project-specific specifications, owner vigilance, contract enforcement, and contractor diligence. Cost savings can be realized by minimizing damage to the historic structure in the course of construction work. Even more importantly, a successful protection program controls risks and hazards that could otherwise result in the loss of significant historic materials and finishes — or an entire building.

NOTES

¹NFPA 241 is available from the National Fire Protection Association, Quincy, Massachusetts, telephone 800-344-3555.

²AIA Document A201, General Conditions of the Contract for Construction, Paragraph 3.3.1.

³AIA Document A201, Paragraph 4.2.3.

⁴AIA Document A201, 10.2.1.3.

For further reference, see *Preservation Tech Notes* Number 18 on paint removal and Number 10 on temporary protection of historic stairways.

This PRESERVATION TECH NOTE was prepared by the National Park Service. Charles E. Fisher, Preservation Assistance Division, National Park Service, serves as Technical Editor of the series. Special thanks go to Marilyn Kaplan of Preservation/Architecture, for her comments and review, and to Annabelle Radcliffe-Trenner, AIA, RIBA, Ford Farewell Mills and Gatch Architects; Nancy Davis and Lonnie Hovey, AIA, The Octagon; Caroline Alderson and Daniel Niner, General Services Administration; and Martha L. Werenfels, AIA, Irving B. Haynes and Associates, Architects, for their assistance.

Thanks also go to Ward Jandi, Timothy Buehner, Michael Auer, Kay Weeks, and Dalhia Hernandez of the Preservation Assistance Division.

Cover Photo: Urban Archives, Temple University, Philadelphia

PRESERVATION TECH NOTES are designed to provide practical information on traditional and innovative techniques for successfully

maintaining and preserving cultural resources. All techniques and practices described herein conform to established National Park Service policies, procedures and standards. This Tech Note was prepared pursuant to the National Historic Preservation Act, as amended, which direct the Secretary of the Interior to develop and make available to government agencies and individuals information concerning professional methods and techniques for the preservation of historic properties.

Comments on the usefulness of this information are welcomed and should be addressed to Tech Notes, Preservation Assistance Division, National Park Service, P.O. Box 37127, Washington, D.C. 20013-7127.



LAWRENCE-WENTWORTH HOUSE

Lowell, Massachusetts

The Lawrence-Wentworth House, originally the home of one of Lowell's antebellum mill owners, has had numerous alterations and changes in use since its construction in 1831. Its original Greek Revival street facade was altered sometime after the Civil War to such an extent that it appears more Victorian than Greek Revival.

Beginning at the turn of the century, the single family residence was converted to a boarding house, a succession of commercial uses, and finally to offices for a social service organization. Sometime during this series of changes, the Victorian double-hung wooden sash on the first floor were replaced with mill finish aluminum jalousies as shown in the above photograph of the rear facade. The Victorian wooden sash, consisting of a two-over-two (2/2) light configuration, survived on the second floor.

After experiencing several years of sizable increases in energy costs, coupled with the inherently poor thermal performance of the jalousie sash on the first floor, the owner, Unitas, Inc., a service organization to Lowell's Hispanic community, came to the Lowell Historic Preservation Commission requesting assistance in replacing these visually obtrusive and thermally inadequate windows.

Design Problem

The Victorian 2/2 sash on the second floor were still in serviceable condition and were already fitted with storm windows. Consideration was therefore given to the installation of 2/2 replacement sash and frames on the first floor that would match the visual qualities of the remaining historic windows and at the same time incorporate the energy efficiency features of double glazing and weather stripping. Another important goal was to reduce cost without altering the appearance of the windows or affecting their performance.

Design Solution

Studies have shown that when treated with a water repellent coating, and properly fabricated and installed, new wood windows will provide long service. Since the exterior wood siding, trim, upper floor windows and painted masonry would all require periodic repainting, this maintenance consideration was not a major factor in the decision to install wooden replacement windows.

A full-scale measured drawing was made of an existing second floor window as a guide in detailing the replacement window. This investigation revealed that the single-glazed 2/2 sash were 1 3/8" thick, and that the entire width of the box frame was exposed on the exterior.

In reaching the decision to install wooden windows, the important techni-

PRESERVATION

Tech Notes

NATIONAL PARK SERVICE
U.S. DEPARTMENT OF THE INTERIOR
WASHINGTON, D.C.

WINDOWS NUMBER 6

Replacement Wooden Sash and Frames With Insulating Glass and Integral Muntins

Charles Parrott

Lowell Historic Preservation Commission
U.S. Department of the Interior

Replacement of missing architectural features or insensitive later replacements should be based on accurate duplication of features, substantiated by historic, physical, or pictorial evidence. The composition, design, color, texture and other visual qualities of the historic feature should be matched.

cal issue was the treatment of the vertical muntin in both the upper and lower sash. The narrow appearance of the $\frac{3}{4}$ " muntin in the historic sash presented some problems, since insulating glass was preferred for the new windows and required a wider muntin for proper installation. The alternative of using new single glazed wooden windows, with a separate interior or exterior storm unit added, was less desirable in this case since such windows would be more troublesome to open.

The selected replacement sash were designed to have two individual lights of insulating glass in each sash with an integral (as opposed to a "fake" or applied) muntin. Based on the experience gained by the Lowell Historic Preservation Commission in previous projects, the muntin of the new sash was made only 1" wide, closely matching the appearance of the historic $\frac{3}{4}$ " wide vertical muntins remaining in the upper floor windows (see figure 1). This slight change in muntin width is hardly noticeable. The results might have been different if the old and new sash had existed side by side; if the number of panes had been greater and the panes themselves been smaller; or if the historic muntins had been thinner.

The new sash were made $1\frac{3}{4}$ " thick, an increase of $\frac{3}{8}$ " over the historic sash, in order to allow a sufficiently deep rabbet in which to set the $\frac{7}{16}$ " insulating glass and to provide added support for the double weight of the glass.

Fabrication and Installation

Along with full scale working drawings for the new window, written specifications for both sash and frame fabrication and installation were prepared. These documents were sent to several window shops and installation contractors to obtain separate quotations for fabrication and installation.

The ten new windows were to be delivered fully primed and assembled. Of the ten windows, six were detailed for masonry openings and four for frame openings. No more than two windows were the same size, and there were seven different sizes in all. Only the six principal windows, averaging 21 square feet each, were of 2/2 configuration. Replacements for the four smaller jalousie windows, positioned in less prominent rear or side locations, away from the front of the building, were designed in 1/1 light configuration, but were otherwise identical to the larger windows.

Two types of a commercially-available rigid metal weather stripping, formed

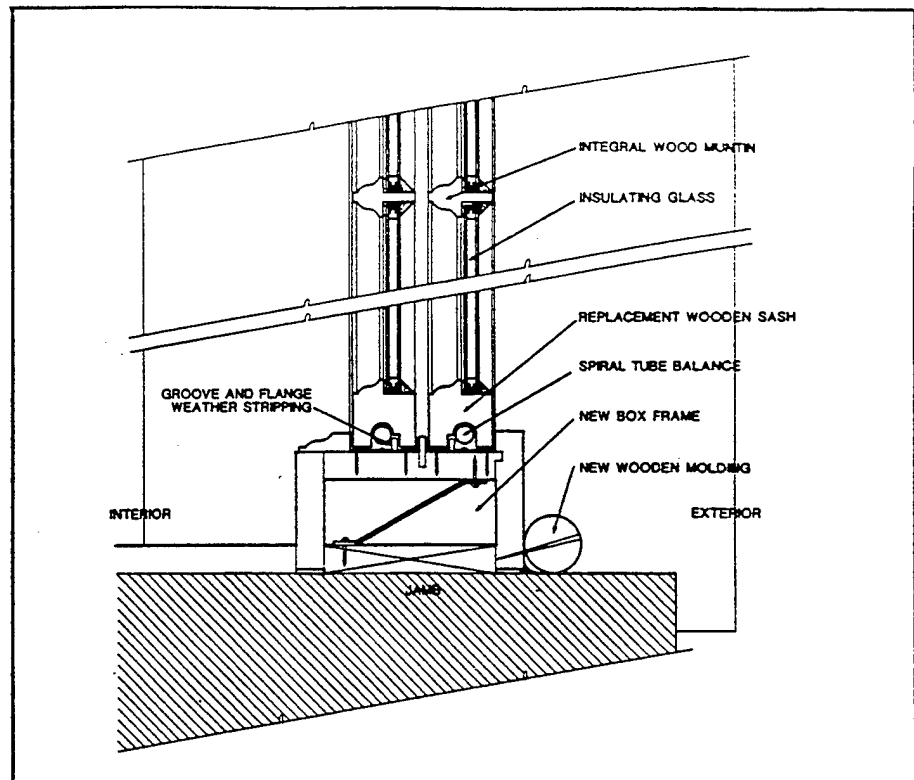

Figure 1. The wooden replacement windows had two individual lights of insulating glass in each sash with an integral (as opposed to "fake") muntin. Drawing: Penelope S. Watson

from rolled zinc sheets, were installed in preference to a less permanent vinyl, foamed plastic, or spring-metal weather stripping. At the heads, jambs and sills, the weather stripping consists of a continuous flange over which fit the grooved rails and stiles. At the meeting rail, the weather stripping consists of two interlocking hooks (see figure 2). The weather stripping protrudes only a short distance above and below the meeting rails along the jambs and is almost totally concealed when the windows are shut. It is extremely durable and is virtually unaffected by corrosion or chemical decomposition.

The sealed insulating glass units, installed in the fabricator's shop, were first caulked with a thin bead of non-hardening water-based (containing no oil) sealant. The sealant was applied at the corner of the glass unit so as not to touch the butyl compound used to seal the edge of the insulating glass (see figure 3). The water-based sealant serves as an important barrier between the separate butyl-seal on the insulating glass and the standard oil-based glazing compound as used in the actual glazing. The oil-based glazing compound was chosen in preference to the standard wood molding strips to provide a cheaper, more flexible and more weather-resistant

glazing. It also matches the historic glazing treatment.

The historic windows in the Lawrence-Wentworth House were balanced in standard fashion with sash weights and pulleys. Since many were missing on the first floor, less costly spiral tube balances were specified for the new windows (see figure 1). The spiral tube balances were attached at their top to the face of the jamb near the top of the window. The longer balance tube for the lower sash, therefore, is visible above the closed lower sash inside the building, just as the sash cord is exposed on a weight balanced sash. The tube balances, however, are not seen from the exterior and their use permitted a more energy efficient window frame. The empty boxes, which would have held the sash weights, were filled with insulation; air infiltration was further reduced since there were no pulley mortises in the frame.

The spiral balances also allowed the use of a less expensive L-shaped, shop-fabricated frame, and the look of the historic box frame was accomplished with masonry-anchored nailers, steel framing clips, and flat interior casing stock (see figure 1).

The new wooden frame was thus identical in appearance to the historic frame on the building. The width of the historic frame was reproduced along with the wooden brick molding used to trim the exterior of the masonry openings (see figure 4).

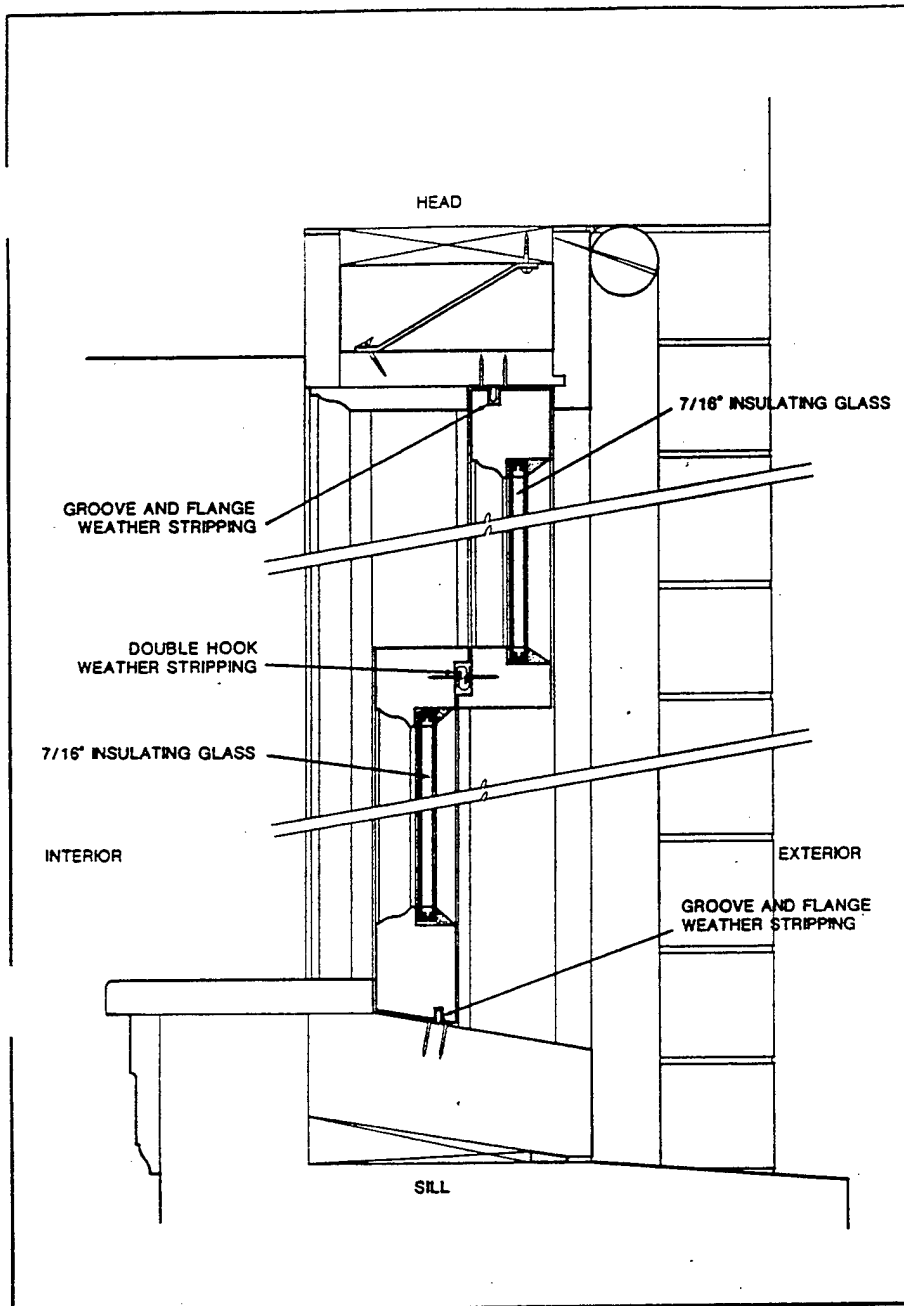

Figure 2. Several types of zinc weather stripping were used. Drawing: Penelope S. Watson

Project Costs

The ten windows were fabricated to specification, including such features as wood preservative treatment and sash locks, for \$2520 (\$13.40 per square foot).

The installation work, undertaken in 1983, included preparation of the window openings; installation of the windows and interior stops; and the attachment of exterior brick molding and all interior trim, which had been selected from flat or molded stock. Priming unprimed elements and caulking were also included in the installation work, which totaled \$1800 (\$9.52 per square foot).

Total cost of the ten windows less finish painting, which was done as part of the general exterior repainting, was \$4320 (\$22.92 per square foot). Wooden frame half screens mounted on the interior and set in aluminum tracks were also furnished and installed for a total of \$490 for the ten windows.

Project Evaluation

The window work on the Lawrence-Wentworth House shows the practicality of replacing windows on a selective basis. In replacing only the first floor windows, significant cost savings were achieved and the 2/2 Victorian windows on the second floor were saved. This project clearly shows that energy conservation and other cost-reducing measures can be achieved in replacement windows that reproduce the visual qualities of the historic windows. The use of spiral balances and insulating glass, the increase in the sash thickness, modifications to the box frames, and the slight widening of the integral wood muntin were accomplished in a sensitive way in keeping with the Secretary of the Interior's "Standards for Rehabilitation." This approach has limitations, especially when dealing with very thin historic muntins, where to accommodate the weight of insulating glass and for suitable glazing, the width of the muntin would have to be increased substantially. In many cases, however, involving two- and four-light sash, this application can be adopted without perceptibly increasing the width of the muntin or diminishing the historic character of the window.

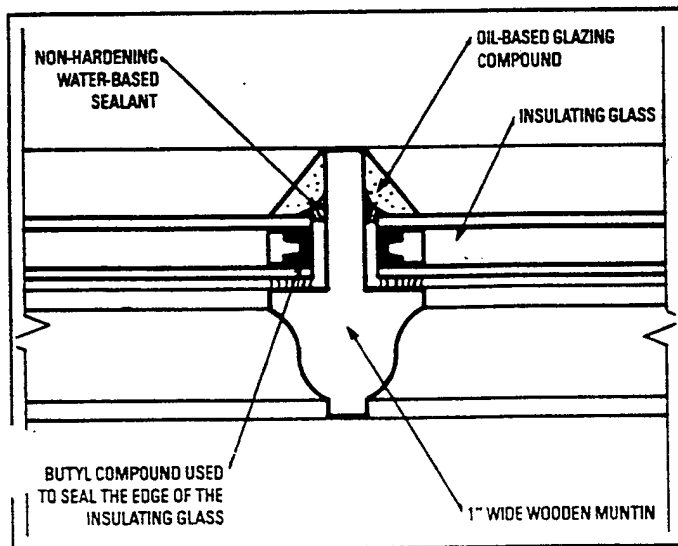

Figure 3. Glazing detail shows how the non-hardening water-based glazing sealant was used to separate the butyl compound (used to seal the insulating glass) from the oil-based glazing compound. Drawing: Penelope S. Watson

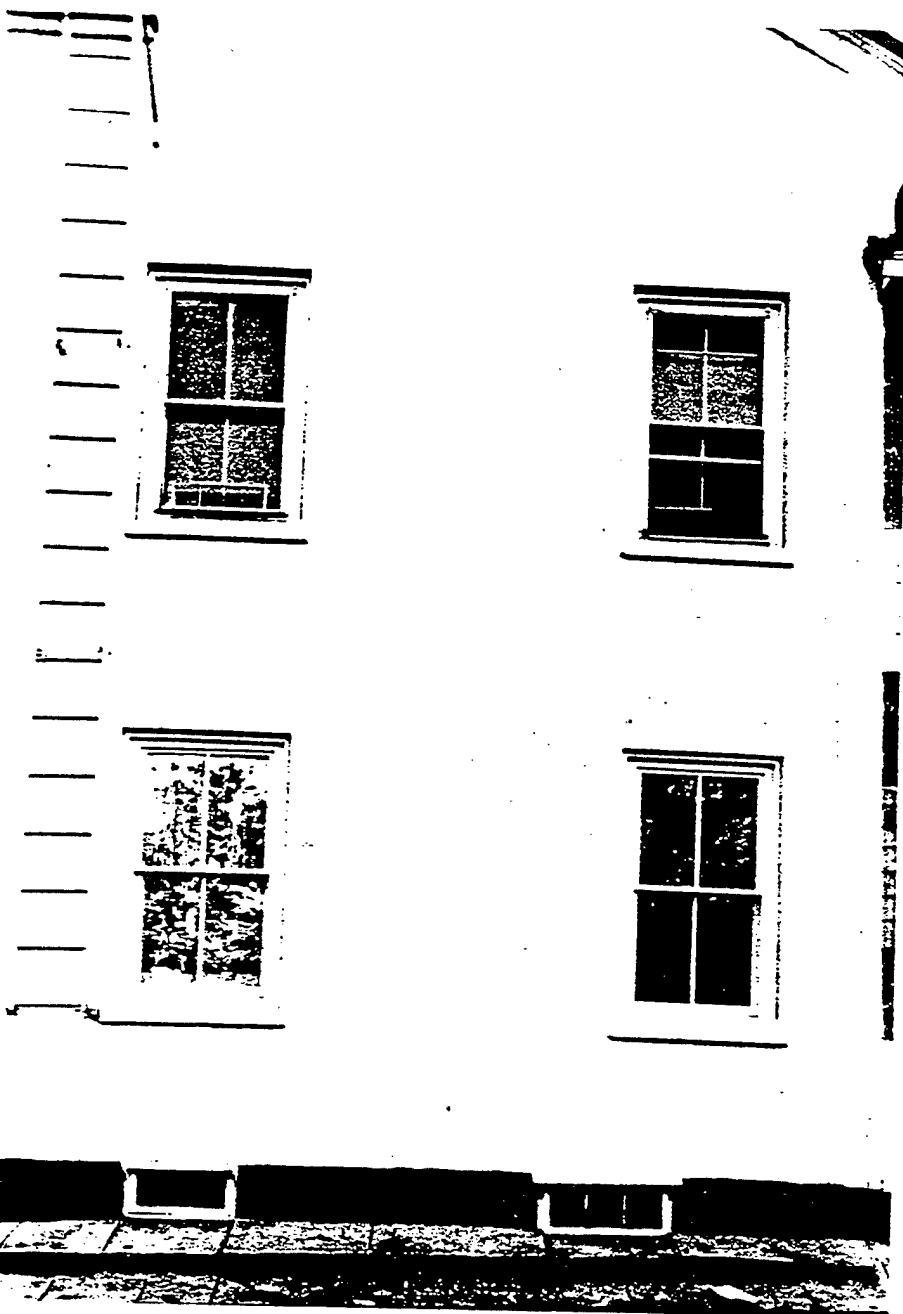

Figure 4. The new wooden windows on the first floor with insulating glass installed closely matched the historic windows which were preserved on the upper floor. Photo: Charles Parrott

This PRESERVATION TECH NOTE was prepared by the National Park Service in cooperation with the Lowell Historic Preservation Commission, and the Center for Architectural Conservation, Georgia Institute of Technology. Charles E. Fisher, Preservation Assistance Division, National Park Service, serves as Technical Coordinator for the TECH NOTES. Special thanks go to the following people who contributed to the production of this TECH NOTE: John H. Myers, Center for Architectural Conservation, Penelope S. Watson of the Lowell Historic Preservation Commission, and Preservation Assistance Division staff, particularly Michael J. Auer, Martha A. Gutrick, and Mae Simon. Photo on page 1 by Jim Higgins.

This and many of the TECH NOTES on windows are included in "The Window Handbook: Successful Strategies for Rehabilitating Windows in Historic Buildings" (available late 1984), a joint publication of the Preservation Assistance Division, National Park Service and the Center for Architectural Conservation, Georgia Institute of Technology. For information, write to The Center for Architectural Conservation, P.O. Box 93402, Atlanta, Georgia 30377.

PROJECT DATA

Building:

Lawrence-Wentworth House
48 Lawrence Street
Lowell, Massachusetts

Owner:

Unitas Inc.
48 Lawrence Street
Lowell, Massachusetts

Project date: Early 1983

Design Staff:

Lowell Historic Preservation
Commission
204 Middle Street
Lowell, Massachusetts

Fabrication:

The Window Shop
250 Chandler Street
Worcester, Massachusetts

Materials:

Weather Stripping-
Southern Metal Products
3950 Swinner Road
Memphis, Tennessee

Sash Balances-
Caldwell Manufacturing Company
64 Commercial Street
Rochester, New York

Sealed Insulating Glass-
Economy Glass Corp.
315 Columbus Avenue
Boston, Massachusetts

Project Costs:

The fabrication cost, including priming, of the 10 windows (7 different sizes) was \$2520 (\$13.40 per square foot); installation cost was \$1800 (\$9.52 per square foot); total cost was \$4320 (\$22.92 per square foot).

PRESERVATION TECH NOTES are designed to provide practical information on innovative techniques and practices for successfully maintaining and preserving cultural resources. All techniques and practices described herein conform to established National Park Service policies, procedures, and standards. This TECH NOTE was prepared pursuant to the National Historic Preservation Act Amendments of 1980 which directs the Secretary of the Interior to develop and make available to government agencies and individuals information concerning professional methods and techniques for the preservation of historic properties.

Comments on the usefulness of this information are welcomed and should be addressed to TECH NOTES, Preservation Assistance Division, National Park Service, Washington, D.C. 20240. This publication is not copyrighted and can be reproduced without penalty. Normal procedures for credit to the author and the National Park Service are appreciated.

ISSN: 0741-9023

PTN-6

January 1984



U.S. Department of the Interior
National Park Service
Cultural Resources

Preservation Assistance Division

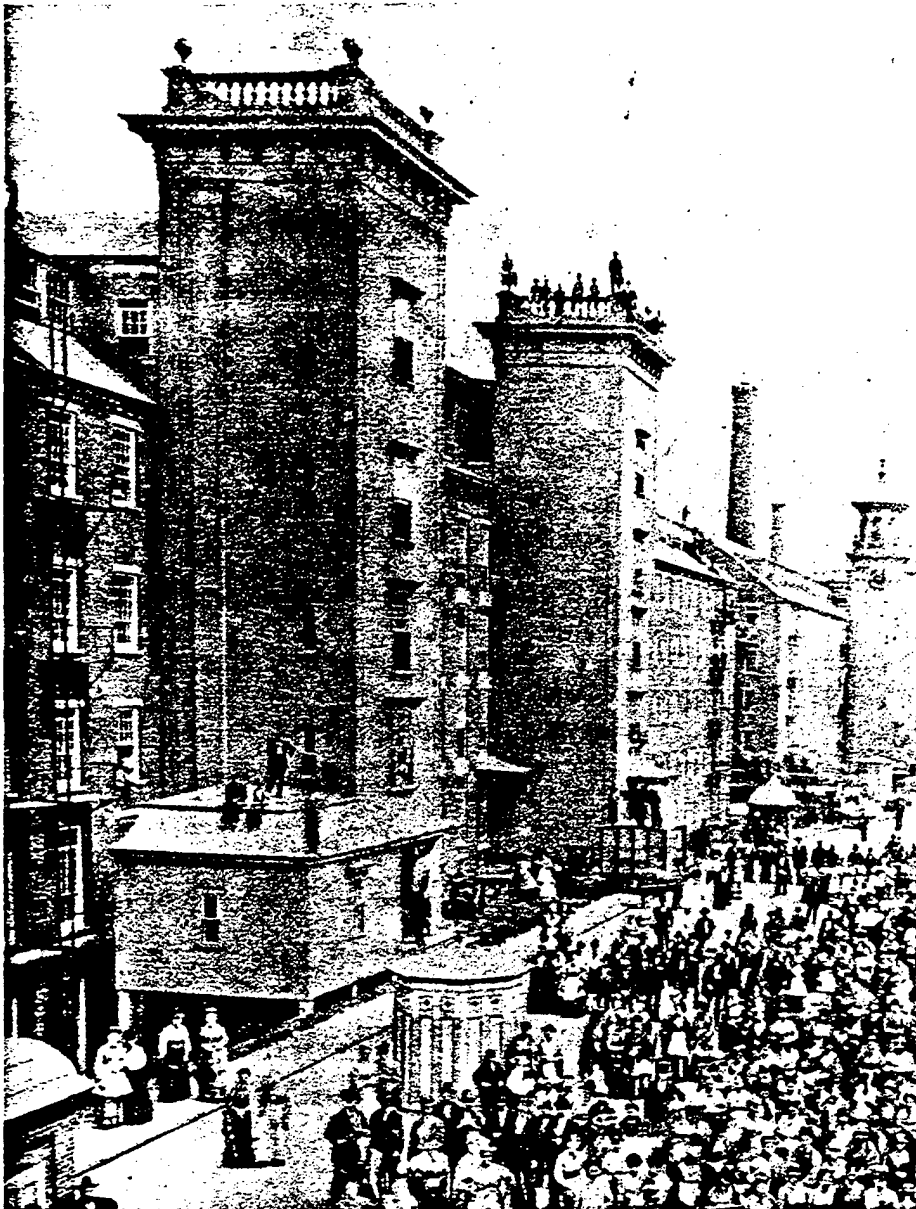

WINDOWS

NUMBER 18

Aluminum Replacement Windows With True Divided Lights, Interior Piggyback Storm Panels, and Exposed Historic Wooden Frames

Charles Parrott
Lowell Historic Preservation
Commission

BOOTT COTTON MILLS (The Boott Mills) Lowell, Massachusetts

The complex of buildings which make up the Boott Mills is considered one of the best examples of a large 19th-century New England textile factory. The 3,000 double-hung windows, most of which are 3½' x 7' in size, are a distinguishing characteristic of this interconnected red-brick grouping of nine mills, a counting house, and a cotton storehouse. The point-grid patterning of these windows, rhythmically punched into the multi-story plain brick walls, and the nearly uniform 12-over-12 configuration of lights tightly stretched over the facades, creates an austere yet powerful composition evident not just in the first four mills of the mid-1830s but in

the additions that continued until 1899. Rather than being subservient to more richly detailed wall treatment, the windows became the dominant element of detail and decoration for the Boott Cotton Mills. Many other textile mills of the 19th century could be characterized in this way.

The rehabilitation of the Boott Mills complex, located in a National Historic Landmark district, presented the opportunity to arrest decades of neglect and deterioration and to re-establish the important historical and architectural contribution of the windows. This Tech Note will explain the work that led to an innovative solution, combining alu-

Deteriorated historic windows should be repaired rather than replaced wherever possible. When replacement is necessary, the new windows should match the historic ones in design, color, size, configuration, reflective qualities, shadow lines, detail and material. Only where it is not feasible to match the historic material should a substitute be considered and only when it is shown through such means as field mock-ups that it is possible to match closely both the detail and the overall appearance of the historic windows.

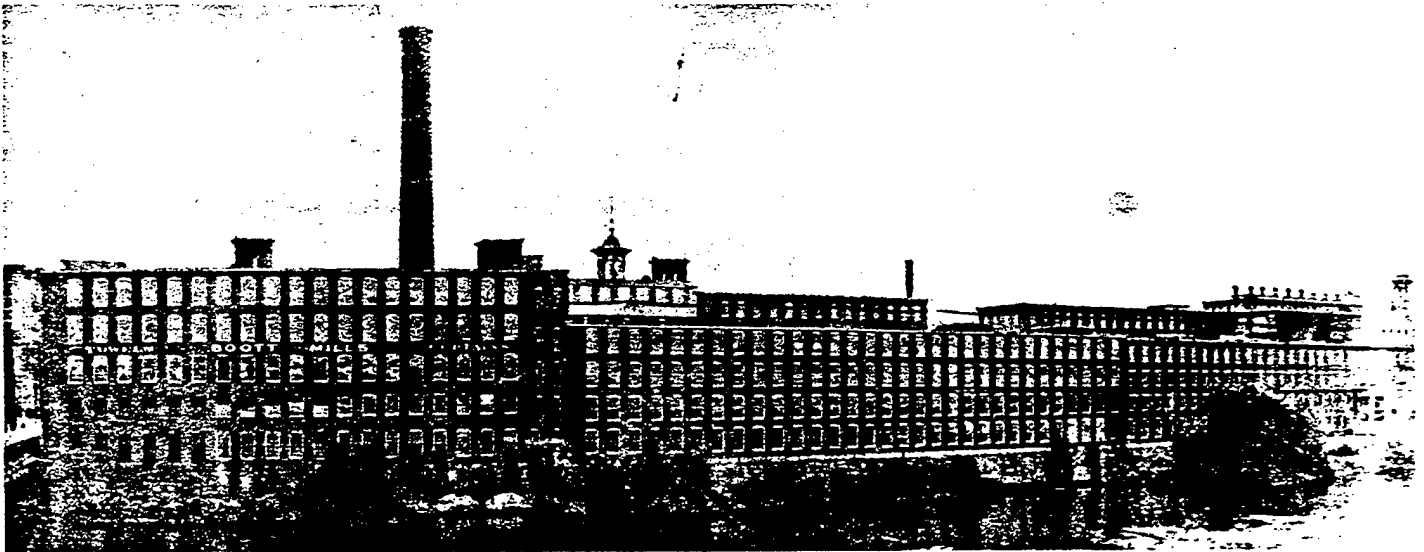

Figure 1. The windows are the dominant element of detail and decoration in the Boott Cotton Mills. Photo: Courtesy of the Center for Lowell History

minum window technology with an older double-glazing technique. The new windows that were developed virtually duplicated many of the important historic attributes of the original wooden windows on the large mill facades (see figure 1).

Problem

The projected three-phase, \$63 million rehabilitation of the Boott Mills involves 700,000 square feet of space. An appropriate window treatment was foremost among several important preservation design problems. The developer and the historic review commission agreed that one-over-one aluminum replacement windows with exterior muntin grids were not desirable. Because of the significance of the complex, it was established that the windows needed to have true divided lights and that the dimensions and profiles of all visible elements would be near copies of the originals (see figure 2).

Restoration of the existing windows was one solution that was considered. This approach was undertaken on one late 19th century facade where the windows retained structural integrity due to oversize muntins and a mild weather exposure. However, the results of the architect's survey of the windows concluded that the vast majority of the surviving wooden sash were deteriorated well beyond repair. The historic windows had indeed fared badly in the decades following the collapse of the New England textile industry after World War I. The lack of proper building maintenance beginning at that time has been documented by historians studying the business and labor history of the Boott Mills. The only significant win-

dow work during the waning textile operation at the mill resulted in the spot replacement of many of the 12 light sash with 6 light sash. Virtually no work, including painting, had been done on the windows following the cessation of textile production in 1954. The one exception was the replacement of several hundred windows on the exposed river elevations that had been destroyed by an off-site explosion in 1976 and replaced with inexpensive aluminum double-hung, single light sash.

The developer and architect next investigated the replacement with wooden reproduction windows. Several wooden window manufacturers were approached for design and price quotations for a custom window with true divided light sash that maintained the historic sight lines of the visible members of the window. At the same time, the project team investigated the possibility of developing an aluminum true-divided-light sash that would satisfactorily duplicate the historic wooden window while providing for double glazing. A new aluminum window system would result from their efforts.

Window Design

In the fall of 1988 the developer and architect turned to a manufacturer with whom they had previously worked and proposed the development of a vertical sliding aluminum sash window which would contain true divided lights with thin muntins and members with dimensions and finish profiles that match those of the historic wooden window.

Over the next few months, the following basic requirements were established for the new window:

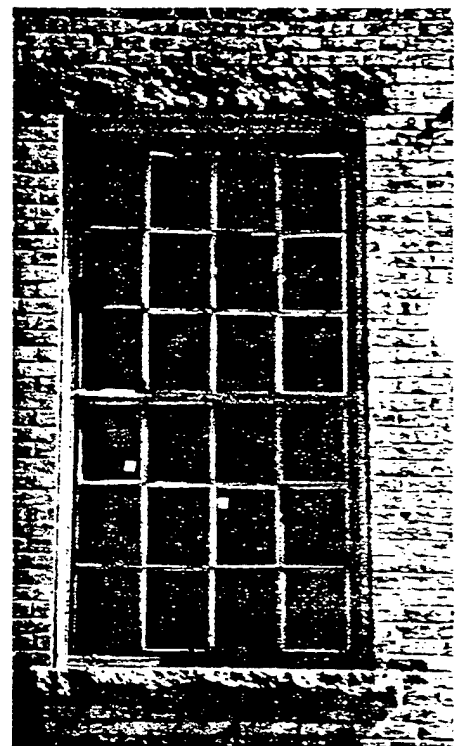

Figure 2. Because of the historic character and significance of the complex, replacement sash needed to have true divided lights and the dimensions and profiles of visible elements needed to be close copies of the originals. Photo: Courtesy of Huygens DiMella Shaffer

1. True-divided lights/integral muntins
2. Dimensions and profiles of all visible members that virtually duplicate the historic window
3. "Wet" glazing for small divided lights.
4. Double glazing
5. Thermally broken unit
6. Aluminum construction with factory-applied paint

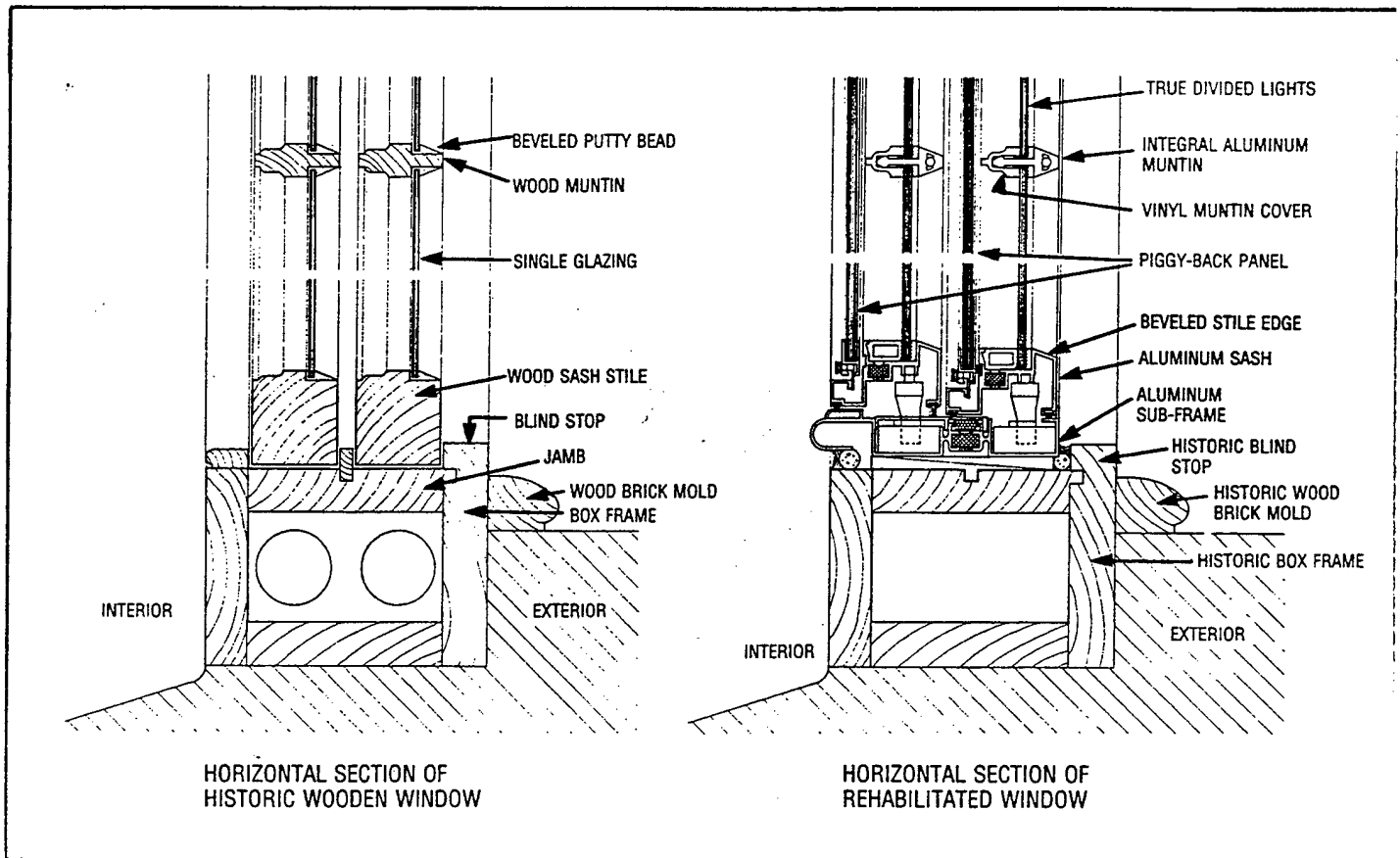

Figure 3. Horizontal section of the window shown with old and new sash. Drawing: Timothy Buehner

7. Conventionally weatherstripped and counterbalanced vertical sliding sash
8. Retention of the historic wooden frame as the receptor for the new window system

Although the latter five requirements are typical of most recent historic building rehabilitations, achieving the first two demanded that a new window system be developed. Recent aluminum replacement windows on historic rehabilitation projects were nearly all based on available window systems, limiting the flexibility to closely match specific windows on a project-by-project basis. In addition, the thin muntins typical of 19th century multiple-light sash could only be achieved through use of an exterior aluminum trapezoidal grid against the exterior sheet of glass. The near-universal industry use of sealed insulating glass necessitated true-divided aluminum muntins that were excessively wide. In the case of the Boott Mills, use of a standard true divided light aluminum window with insulating glass would require muntins over twice the width of the historic $\frac{5}{8}$ "-wide wood muntins.

In order to permit the use of true muntins of sufficient narrowness at the

Boott Mills, it was necessary to limit the muntin-supported glass panes to single glazing, as in a historic window, and to achieve double glazing with a secondary window system (see figure 3). This secondary window consisted of a "piggy-back" interior glazing panel, which left exposed on the exterior the multiple facets of the true divided lights so characteristic of historic multiple-pane windows. The interior glazing panel was attached to the room side of the sash. It was also decided that the existing wooden frames would be retained and used to receive the aluminum sub-frame for the new window. Finally, new aluminum extrusions were to be made for all members to ensure a very close match to the historic units.

The design work evolved into a back-and-forth exchange of full-scale details between the architect, developer, contractor, and manufacturer. First, the architect produced section details of the late 19th-century window at Boott Mills to serve as a basis for sight-line matching. (The early 19th-century windows were similar, but had thinner sash members, a flat-headed masonry opening instead of an arched opening, and generally a smaller overall height.) From these drawings, the manufacturer began to design the new window.

Window Detailing

The manufacturer's initial design roughed out the first technical details for the new system, including:

- duplication of the face dimensions of the meeting and lower sash rails;
- duplication of the face dimensions of the stiles and head rail, taking into account the addition of the new aluminum sub-frame;
- vinyl snap-on interior grid to snugly fit the glass against the sealant, provide a thermal break and approximate the appearance of the interior profile of the muntin; and
- extruded reveals in the sash to receive the piggy-back panels so as to conceal the panel frames from the exterior;
- thin sill extension of the sub-frame beyond the exterior face of the lower sash to minimize the introduction of a non-historic double sill; and
- shaft extension of the sash-lock arm to extend below the intruding piggy-back panel of the upper sash.

The first muntin design was an adaptation of the true-divided-light muntin developed by the manufacturer in 1985 for another historic rehabilitation project (see Tech Note Windows No. 12). It

was narrowed and profiled to approximate the beveled glazing bead and sticking of the historic wooden muntins. However, it was found that the technology of the 1985 three-piece muntin system could be reduced only to about $\frac{7}{8}$ " in thickness. A new two-piece true muntin was then developed by the manufacturer that met the general dimensions and profile of the putty-glazed historic muntin; it provided the needed strength and proved to be simpler in design and less expensive to fabricate. This muntin consisted of an aluminum tee extrusion with a trapezoidal flange and a web terminating in a triangle-shaped point over which a profiled cover of extruded rigid PVC was snapped to hold the glass panes in place. Plastic was used for this cover to provide the flexibility needed to remove the cover in case of glass breakage and to provide the thermal break to insulate the aluminum tee member. The snap cover extrusion was to be made in the pre-selected custom color chosen for the window (see figure 4).



Figure 4. The decision to use an integral muntin for the outer glazing and a piggy-back interior glazing panel was an important component of the successful window solution. Sash shown before and after rehabilitation. Photos: Charles Parrott

The framing and new muntin designs were supplied to the architect who prepared full-scale sections to show how the new window would be installed in a repaired window frame. To conform more precisely to the visible features of the late 19th-century window, the architect modified the inside edge of the rail and stile extrusions to include the beveled shape of the historic glazing putty. Revisions were incorporated by the manufacturer as the design evolved and further refinements were added.

On the sub-frame, a drip edge that broke the sight line at the head was eliminated as unnecessary. The detailing of the sub-frame was also revised to facilitate installation into the existing frame from the building interior. This resulted in a cleaner interior finish; however, it also increased the height of the sub-sill, making it somewhat more visible on the exterior. The overall depth of the early design was also reduced, resulting in a final depth only about $\frac{1}{2}$ " larger than the historic window. Because the muntin had to clear the piggy-back panel behind it, the overall muntin depth was to be $1\frac{1}{16}$ ", just $\frac{3}{16}$ " less than the historic ones (see figure 5).

Refinements were also made to the piggy-back panel. In the original version, they were clipped into a frame reveal on the inner face of each aluminum sash. As revised, the panel frame was fastened more substantially using receptor channels along the rails of both sash and tamper-proof turn buttons fixed into

a slot along the stiles. This modification greatly eased panel removal and reinstallation for cleaning and maintenance. It also produced a cleaner, more finished interior appearance.

Before die production was initiated by the manufacturer, a full-scale mock-up of one typical window was custom-built from aluminum stock, duplicating the exterior sight lines of the new extrusions. The window was then compared visually to a repaired and painted existing wooden window, to determine whether the new window sufficiently matched the historic appearance.

After evaluating the mock-up, two additional extrusions were developed at the recommendation of local preservation officials to create a narrower meeting rail for use in certain windows. This was determined necessary since the early 19th-century sash had sight lines much narrower than the later ones—all face widths of sash members were $\frac{3}{4}$ " narrower. Since this was especially noticeable at the extremely narrow $\frac{3}{4}$ " meeting rail of these early windows, an alternate extrusion pair was developed that narrowed the meeting rail to $1\frac{1}{8}$ ", for use where the early 19th-century sash were to be replaced. The $1\frac{1}{8}$ " was as narrow as technically possible.

Existing Technology

Various features of the new window involved relatively standard aluminum window industry auxiliary materials and design techniques. These carefully se-

lected components permitted most of the development costs to address visual requirements. These components included:

- block-and-tackle sash balances for the lower sash—the upper sash is fixed but removable for maintenance;
- an insulating, plastic thermal break between the interior and exterior halves of the sash frame;
- plastic "wool" pile with fin seal (at head, meeting rail and jambs) and vinyl bulb (at sill) weatherstripping held in shallow slots in each extrusion to control air and water infiltration between both moving and fixed extrusions;
- silicone rubber-edge blocks to cushion the glass panes against their rabbets in the aluminum extrusions;
- "wet" sealant (silicone) to glaze the small individual lights; and
- custom-colored, rigid PVC snap covers at the jambs to cover the sash balances and provide a weather seal.

The muntin joinery also applied existing techniques to the problem of creating a structural grid capable of adequately supporting independent glass panes (just as in a wooden multiple-light sash.) As in a wooden window, the vertical muntins are continuous from rail to rail, with horizontal muntins individually pieced in between. The continuous vertical member minimizes the introduction of water into the joint, just as it does in a wooden window. The ends of the horizontal bars are coped to the profile of the extrusion, and the vertical

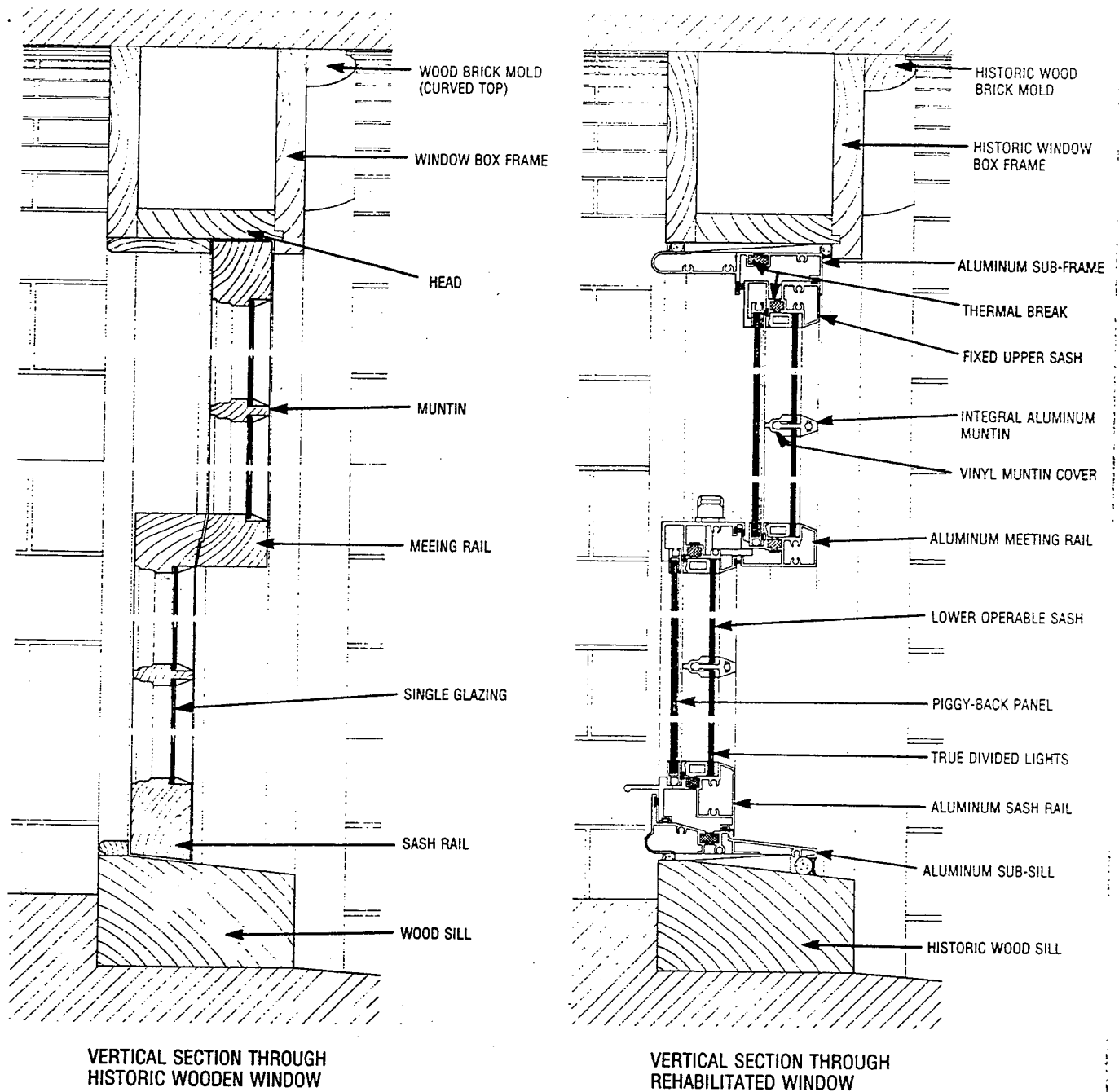

Figure 5. Vertical section of the window shown with old and new sash. Drawing: Timothy Buehner

muntin is drilled to accept a stainless steel pin which is force fit through the connection. An extruded longitudinal hole through the muntin accepts the pin into the horizontal members. Where the muntins intersect the stile and rail extrusions, a welded connection is used to minimize the penetration of water into those members. The interior snap cover is cut and fit in like manner—continuous vertical members with pieced-in horizontal sections coped around the ogee profile.

Window Fabrication and Installation

After approval of the mock-up for its ability to reproduce the appearance of the historic wooden windows, cutting of dies and production of extrusions proceeded during the summer and fall of 1989. A full scale window was constructed for performance testing to the standards of the American Architectural Manufacturers Association (AAMA), the industry's standard-setting body for

aluminum windows. The performance evaluation was done by an independent testing laboratory and was certified to meet the specified standards. By spring 1990, the new windows were being installed at the site.

Windows were fabricated in several different sizes according to the dimensions of the sash opening of the existing wooden frames. All new sash had 12 lights or more, replicating the configuration of the original sash.

The aluminum components of the



Figure 6. Work on the frames consisted largely of making dutchman repairs to the pulley stiles where required; renailing or replacing brick moldings; replacing some sills; and surface preparation. Photo: Charles Fisher

sub-frames and sash, including piggy-back panels, were first cut and assembled, then painted a light grey color. The assembled windows were shipped to the job site complete with weatherstripping, balances, and glazing.

Site Preparation and Installation

While the new aluminum sash were being fabricated, the work at the site involved the removal of the remaining wooden sash, along with interior stops and parting beads, and the repair, preparation and painting of the frames. New wooden frames were required for openings previously filled with glass block or masonry.

The exterior of the wooden frames were not to be panned or covered in aluminum. Thus it was important both for aesthetic consideration and good paint performance that the wood frames be repaired and surfaces properly finished. Work on the frames consisted largely of making dutchman repairs to the pulley stiles where required; renailing or replacing brick molding; replacing some sills; and scraping, filling and sanding wood surfaces. Painting consisted of priming and two coats of alkyd oil paint (see figure 6).

Installation of the new sash went quickly and smoothly. First, the sub-frame was inserted in the prepared opening from the room side, shimming to plumb, line and level before attaching screws through the head and jambs into the old frame. The sash were then installed and the windows were caulked on both the interior and exterior to complete the work (see figure 7).

Costs

In the first two phases of the project, wooden window frames were repaired and new aluminum sash installed in 522 windows. In addition, new wooden windows were installed in a highly visible entrance location of the first floor. Work on another 1,031 windows remain to be undertaken under the third phase of the project. The standard window averaged about 3½' by 7' or about 25 square feet in area.

Because of the large number of windows needing replacement at the Boott Mills, the associated development costs for the new window were within reason—approximately ten dollars per window. Smaller projects can now benefit from the development of this window system. It is estimated by the manufacturer that an order of 100 windows, involving a 12-over-12 light window like that at Boott Mills (3½' x 7'), would cost today around \$28 per square foot or \$686, plus shipment and installation.

Evaluation

The sash replacement work undertaken to date at the Boott Mills represents an advance in the way in which aluminum windows can be designed to capture more fully the authentic appearance of historic windows in larger buildings while providing good overall performance. The treatment of the muntins and the sash framing elements, the piggy-back glazing panel, and the retention of the exposed historic wooden frame all combined to create a window that was

aesthetically pleasing and that retained many of the important historic qualities of the original windows (see figure 8).

Particularly notable was the development of a true divided-light hung-sash window in aluminum where the muntins reproduced the narrow widths of the historic wooden sash. The use of the piggy back panel to provide double glazing facilitated matching the appearance of the muntin on the primary glazing. By having the primary glazing set within true muntins, the characteristic nuance imparted by individual panes of glass is visible on the outside of the building.

The relatively small size of these mill windows (3½' x 7') made possible the use of true-divided lights with aluminum muntins that matched the dimensions of the historic ones. For very large windows, additional engineering and testing would be necessary to establish the feasibility of this approach.

Another important component of the overall success of the Boott Mill window approach was that new rail and stile framing components closely matched the sight lines of their wooden counterparts. This is especially important with respect to the narrow meeting rail typically found in historic windows. The retention of the historic wooden frame as a finish element of the window system was also an important feature of this project. This avoided the normal practice when installing aluminum replacement units of either removing the wood frame altogether or sheathing it in break metal or an extruded pan,



Figure 7. The retention of the exposed outer face of the historic wooden frame and the sill detailing were important qualities of the window treatment. Before and after photos: Charles Parrott

trimmed with an extruded molding. In the latter case, such work results in the widening of the sight lines of the frame. In addition, the use of aluminum at the frame introduces visible and often additional assembly joints.



Figure 8. Replacement window sash after installation. Photo: Charles Parrott

With the Boott Mills project, the old wooden frame served as a convenient anchor for the replacement window system. With no technical need to cover the historic frame on the outside, it was therefore possible to preserve all the visual qualities of the original wood frames. For the developer, the achievement of the perceived operating and maintenance advantages of a new aluminum window system ended at the old frame, thus allowing its retention as an aesthetic and historical feature. Although the new design is set up for use in the existing wooden window frame, the lengthening of the jamb and head extrusions and redesign of the frame would permit its use in cases where the wooden frames are missing or severely deteriorated beyond repair.

As with any successful window solution, there are opportunities for refinement. Modification of the glazing vinyl gasket and associated extrusions was subsequently acknowledged as an area for potential improvement, to approximate more fully the historic muntin profile around the sash frame. The sill of the aluminum sub-frame could also have been detailed better, following more the slope of the original wood sill.

This special application of aluminum

window technology in response to historic preservation concerns in the rehabilitation of the Boott Mills was the result of a unique combination of individuals and events. Although the cost of this window solution was about the same as a custom replacement wooden window, in terms of historic preservation, it represents a substantial design and technology improvement in aluminum windows (see Tech Note Windows No. 13).

While in many cases the historic character of specific buildings would preclude the use of such a retrofit solution, it has applicability to many large-scale buildings where the existing windows are beyond repair and where replacement with wooden windows, even though upgraded in thermal performance, is not a viable alternative. It illustrates the need for advance planning and the willingness of the developer, the window manufacturer and preservation groups to work together, as they did in this case, to improve the quality of replacement windows installed in historic buildings. In the end, these parties discovered that to achieve a much closer match of a wooden window, the aluminum window had to be built very much like it (see figure 9).

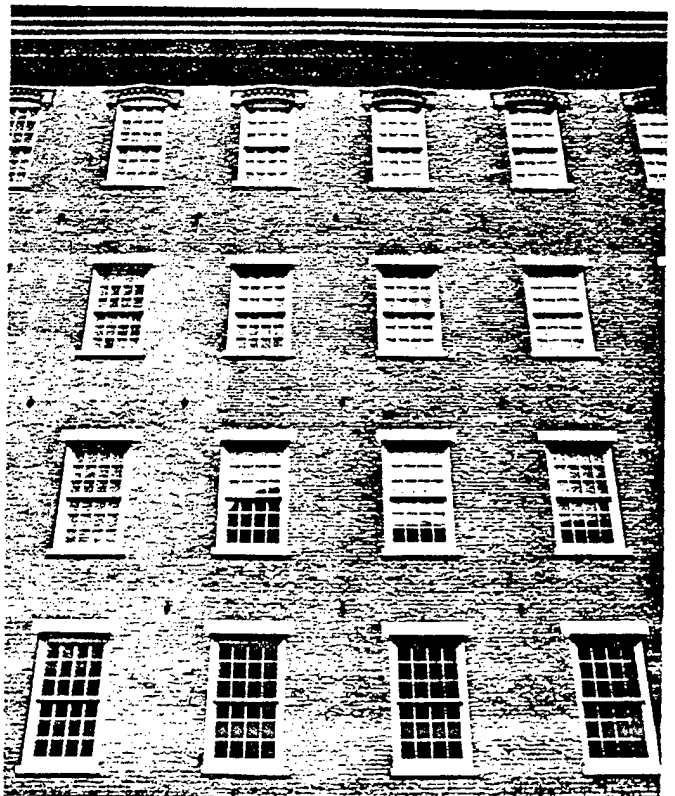

Figure 9. The window solution represents an important advance in the way in which aluminum windows can be designed to capture more fully the appearance of historic windows in larger buildings. Right photo shows wood sash in bottom row and aluminum in the upper three rows. Photos: Jim Higgins ©

PROJECT DATA:**Building:**

The Boott Mills
Lowell, Massachusetts

Developer:

Congress Group Properties
Boston, Massachusetts

Project Date:

1988 —

Developer Representative:

Richard Graf, Vice President
Congress Group Properties

Architect:

Amir Mann
Project Architect
Huygens DiMella Shaffer
Boston, Massachusetts

Preservation Consultant:

William MacRostie
Heritage Consulting Group
Washington, D.C.

Window Manufacturer:

Custom Window Company
Englewood, Colorado

THE PRESERVATION TECH NOTE was prepared by the National Park Service. Charles E. Fisher, Preservation Assistance Division, National Park Service, serves as Technical Editor of the PRESERVATION TECH NOTES. Information on the window work at Boott Cotton Mills was generously supplied by Richard Graf, Vice President, Congress Group Properties; Dick Gann and Allan Brown, Custom Window Company; and William MacRostie, Heritage Consulting Group. The following National Park Service staff also contributed to the production of this Tech Note: Ward Jandl, Michael Auer, Timothy Buehner, Theresa Robinson, Robert Powers and Dalhia Hernandez. Cover historical photo: Center for Lowell History, University of Massachusetts at Lowell.

This and many of the PRESERVATION TECH NOTES on windows are included in "The Window Handbook: Successful Strategies for Rehabilitating Windows in Historic Buildings," a joint publication involving the National Park Service and the Georgia Institute of Technology. For information write: Historic

Preservation Education Foundation, P.O. Box 27080, Central Station, Washington, DC 20038.

PRESERVATION TECH NOTES are designed to provide practical information on traditional practices and innovative techniques for successfully maintaining and preserving cultural resources. All techniques and practices described herein conform to established National Park Service policies, procedures, and standards. This Tech Note was prepared pursuant to the National Historic Preservation Act Amendments of 1980 which direct the Secretary of the Interior to develop and make available to government agencies and individuals information concerning professional methods and techniques for the preservation of historic properties.

Comments on the usefulness of this information are welcomed and should be addressed to PRESERVATION TECH NOTES, Preservation Assistance-424, National Park Service, P.O. Box 37127, Washington, D.C. 20013-7127
ISSN: 0741-9023 PTN 36 November 1991

PRESERVATION BRIEFS

1. The Cleaning and Waterproof Coating of Masonry Buildings.
2. Repointing Mortar Joints in Historic Brick Buildings.
3. Conserving Energy in Historic Buildings.
4. Roofing for Historic Buildings.
6. Dangers of Abrasive Cleaning to Historic Buildings.
10. Exterior Paint Problems on Historic Woodwork.
15. Preservation of Historic Concrete: Problems and General Approaches.
17. Architectural Character: Identifying the Visual Aspects of Historic Buildings as an Aid to Preserving Their Character.
18. Rehabilitating Interiors in Historic Buildings: Identifying and Preserving Character-Defining Features.
24. Heating Ventilating and Cooling Historic Buildings: Problems and Recommended Approaches.
32. Making Historic Properties Accessible.
37. Appropriate Methods for Reducing Lead-Paint Hazards in Historic Housing.

1 PRESERVATION BRIEFS

The Cleaning and Waterproof Coating of Masonry Buildings

Robert C. Mack, A.I.A.



U.S. Department of the Interior National Park Service
Preservation Assistance Division Technical Preservation Services

The inappropriate cleaning and waterproofing of masonry buildings is a major cause of deterioration of the Nation's historic resources. While both treatments may be appropriate in some cases, they may cause serious deterioration in others. The purpose of this leaflet is to provide guidance on the techniques of cleaning and waterproofing, and to explain the consequences of their inappropriate use.

Why Clean?

The reasons for cleaning any building must be considered carefully before arriving at a decision to clean.

- Is the cleaning being done to improve the appearance of the building or to make it look new? The so-called "dirt" actually may be weathered masonry, not accumulated deposits; a portion of the masonry itself thus will be removed if a "clean" appearance is desired.
- Is there any evidence that dirt and pollutants are having a harmful effect on the masonry? Improper cleaning can accelerate the deteriorating effect of pollutants.
- Is the cleaning an effort to "get your project started" and improve public relations? Cleaning may help local groups with short term fund raising, yet cause long term damage to the building.

These concerns may lead to the conclusion that cleaning is not desirable—at least not until further study is made of the building, its environment and possible cleaning methods.

What Is The Dirt?

The general nature and source of dirt on a building must be determined in order to remove it in the most effective, yet least harmful, manner. Soot and smoke, for example, may require a different method of cleaning than oil stains or bird droppings. The "dirt" also may be a weathered or discolored portion of the masonry itself rather than extraneous materials. Removal of part of the masonry thus would be required to obtain a "clean" appearance, leading to loss of detail and gradual erosion of the masonry. Other common cleaning problems include metal stains such as rust or copper stains, and organic matter such as the tendrils left on the masonry after removal of ivy. The source of dirt, such as coal soot, may no longer be a factor in planning for longer term maintenance, or it may be a continuing source of problems. Full evaluation of dirt and its effect on the building may require one or several kinds of expertise: consultants may include building conservators, geologists, chemists, and preservation architects. Other sources of local experience or

information may include building owners in the area, local universities, the State Historic Preservation Officer, and the AIA State Preservation Coordinator.

If the proposed cleaning is to remove paint, it is important in each case to learn whether or not exposed brick is historically appropriate. Many buildings were painted at the time of construction or shortly thereafter; retention of the paint, therefore, may be more appropriate historically than exposing the brick, in spite of current attitudes about "natural" brick. Even in cases where unpainted masonry is appropriate, the retention of the paint may be more practical than removal in terms of long range preservation of the masonry. In some cases, however, removal of the paint may be desirable. For example, the old paint layers may have built up to such an extent that removal is necessary prior to repainting. It is essential, however, that research on the paint type, color, and layering be completed on the entire building before removal.

What Is The Construction Of The Building?

The construction of the building must be considered in developing a cleaning program because inappropriate cleaning can have a corrosive effect on both the masonry and the other building materials.

Incorrectly chosen cleaning products can cause damaging chemical reactions with the masonry itself. For example, the effect of acidic cleaners on marble and limestone generally is recognized. Other masonry products also are subject to adverse chemical reactions with incompatible cleaning products. Thorough understanding of the physical and chemical properties of the masonry can help you avoid the inadvertent selection of damaging cleaning materials.

Other building materials also may be affected by the cleaning process; some chemicals, for example, may have a corrosive effect on paint or glass. The portions of building elements most vulnerable to deterioration may not be visible, such as embedded ends of iron window bars. Other totally unseen items, such as iron cramps or ties which hold the masonry to the structural frame, also may be subject to corrosion from the use of chemicals or even from plain water (Fig. 1). The only way to prevent problems in these cases is to study the building construction in detail and evaluate proposed cleaning methods with this information in mind.

Previous treatments of the building and its surroundings also should be evaluated, if known. Earlier waterproofing applications may make cleaning difficult. Repairs may have been stained to match the building, and cleaning may make



Figure 1. The iron anchor shown here originally was hidden from view. An increase in volume due to rusting created internal pressures on the stone and brick, causing spalling. Careful study of the building construction can result in the identification of these potential problem areas and they can be taken into consideration while planning a cleaning project.

these differences apparent. Salts or other snow removal chemicals used near the building may have dissolved and been absorbed into the masonry, causing potentially serious problems of spalling or efflorescence. Techniques for overcoming each of these problems should be considered prior to the selection of a cleaning method.

Types Of Cleaning

Cleaning methods generally are divided into three major groups: water, chemical, and mechanical (abrasive). Water methods soften the dirt and rinse the deposits from the surface. Chemical cleaners react with the dirt and/or masonry to hasten the removal process; the deposits, reaction products and excess chemicals then are rinsed away with water. Mechanical methods include grit blasting (usually sand blasting), grinders, and sanding discs, which remove the dirt by abrasion and usually are followed by a water rinse. Problems related to each of these cleaning methods will be discussed later in this leaflet.

Planning A Cleaning Project

Once the existing conditions have been evaluated, including the type of dirt and the building materials, planning for the cleaning project can begin.

Environmental concerns: The potential effect of each proposed method of cleaning should be evaluated carefully. Chemical cleaners, even though dilute, may damage trees, shrubs, grass, and plants. Animal life, ranging from domestic pets to song birds to earth worms, also may be affected by the run-off. In addition, mechanical methods can produce hazards through the creation of airborne dust.

The proposed cleaning project also may cause property damage. Wind drift, for example, may carry cleaning



Figure 2. The white deposits are efflorescence, soluble salts deposited on the surface of the masonry. These salts usually originate in the masonry or mortar, migrate from the ground below through capillary action, or are brought in by air pollution. The salts also may be the result of chemical reactions resulting from selection of an improper cleaner.

chemicals onto nearby automobiles, causing etching of the glass or spotting of the paint finish. Similarly, airborne dust can enter surrounding buildings, and excess water can collect in nearby yards and basements.

Personal safety: The potential health dangers of each method proposed for the cleaning project must be considered, and the dangers must be avoided. Both acidic and alkaline chemical cleaners can cause serious injury to cleaning operators and passers-by; injuries can be caused by chemicals in both liquid and vapor forms. Mechanical methods cause dust which can pose a serious health hazard, particularly if the abrasive or the masonry contain silica. Steam cleaning has serious hazards because of high temperatures.

Testing cleaning methods: Several potentially useful cleaning methods should be tested prior to selecting the one for use on the building. The simplest and least dangerous methods should be included—as well as those more complicated. All too often simple methods, such as a low pressure water wash, are not even considered, yet they frequently are effective, safe, and least expensive. Water of slightly higher pressure or with a mild non-ionic detergent additive also may be effective. It is worth repeating that these methods should be tested prior to considering harsher methods; they are safer for the building, safer for the environment, and less expensive.

The level of cleanliness desired also should be determined prior to selection of a cleaning method. Obviously, the intent of cleaning is to remove most of the dirt. A “brand new” appearance, however, may be inappropriate for an older building, and may require an overly harsh cleaning method. It may be wise, therefore, to determine a lower level of acceptable cleaning. The precise amount of residual dirt considered acceptable would depend upon the type of masonry and local conditions.

Cleaning tests, whether using simple or complex methods, should be applied to an area of sufficient size to give a true indication of effectiveness. The test patch should include at least a square yard, and, with large stones, should include several stones and mortar joints. It should be remembered that a single building may have several types of masonry materials and similar materials may have different surface finishes; each of these differing areas should be tested separately. *The results of the tests may well indicate that several methods of cleaning should be used on a single building.*

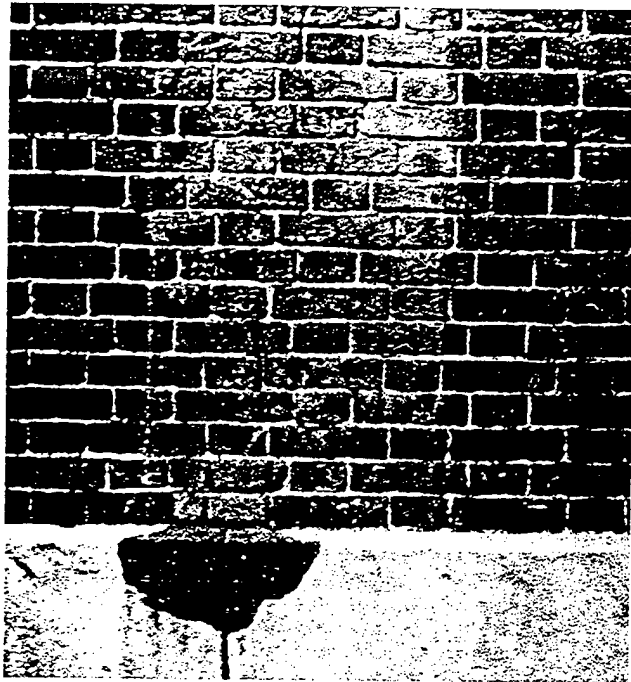

Figure 3. The hazy appearance of a portion of the brick is caused by a residue resulting from cleaning. This film occurred in spite of thorough rinsing. Test patches such as this should always be allowed to weather prior to continuing with the cleaning.

The cleaning budget should include money to pay for these tests. Usually contractors are more willing to conduct a variety of tests if they are reimbursed for their time and materials, particularly if the tests include methods with which the contractor is not familiar.

When feasible, test areas should be allowed to weather for an extended period prior to evaluation. A waiting period of a full year is not unreasonable in order to expose the masonry to a full range of seasons. For any building which is considered historically important, the delay is insignificant compared to the potential damage and disfigurement which may arise from use of an incompletely tested method (Figs. 2-5).

Potential Problems Of Cleaning

Water Cleaning: Water cleaning methods include: (1) low pressure wash over an extended period, (2) moderate to high pressure wash, and (3) steam. Bristle brushes frequently are used to supplement the water wash. All joints, including mortar and sealants, must be sound in order to minimize water penetration to the interior.

Porous masonry may absorb excess amounts of water during the cleaning process and cause damage within the wall or on interior surfaces. Normally, however, water penetrates only part way through even moderately absorbant masonry materials.

Excess water also can bring soluble salts from within the masonry to the surface, forming efflorescences (Fig. 2); in dry climates, the water may evaporate inside the masonry, leaving the salts slightly in back of the surface. The damage which can be caused by soluble salts is explained in more detail later in this leaflet. Efflorescence usually can be traced to a source other than a single water wash.

Another source of surface disfigurement is chemicals such as iron and copper in the water supply; even "soft" water may contain deleterious amounts of these chemicals. Water methods cannot be used during periods of cold



Figure 4. Sandblasting has rounded the corners of this marble capital and pitted the formerly smooth surface. Not only is the stone harmed visually, the increased roughness of the surface also will collect new dirt more quickly than smooth stone.

weather because water within the masonry can freeze, causing spalling and cracking. Since a wall may take over a week to dry after cleaning, no water cleaning should be permitted for several days prior to the first average frost date, or even earlier if local forecasts predict cold weather.

In spite of these potential problems, water methods generally are the simplest to carry out, the safest for the building and the environment, and the least expensive.

Chemical cleaning: Since most chemical cleaners are water based, they have many of the potential problems of plain water. Additional problems of chemical cleaning agents have been mentioned in the discussion of environmental concerns.

Chemical cleaners have other problems as well. Some types of masonry are subject to direct attack by cleaning chemicals. Marble and limestone, for example, are dissolved easily by acidic cleaners, even in dilute forms. Another problem may be a change in the color of the masonry caused by the chemicals, not by removal of dirt; the cleaner also may leave a hazy residue in spite of heavy rinsing (Fig. 3). In addition, chemicals can react with components of mortar, stone, or brick to create soluble salts which can form efflorescences, as mentioned earlier. Historic brick buildings are particularly susceptible to damage from hydrochloric (muriatic) acid, although it is, unfortunately, widely used on these structures.

Mechanical cleaning: Grit blasters, grinders, and sanding discs all operate by *abrading the dirt off the surface* of the masonry, rather than reacting with the dirt and masonry as in water and chemical methods. Since the abrasives do not differentiate between the dirt and the masonry, *some erosion of the masonry surface is inevitable with mechanical methods, especially blasting.* Although a skilled operator can minimize this erosion, some erosion will still take place. In the case of brick, soft stone, detailed carvings, or polished surfaces, even minimal erosion is unacceptable (Figs. 4 and 5). Brick, a fired product, is hardest on the outside where the temperatures were highest; the loss of this "skin" of the brick exposes the softer inner portion to more rapid deterioration. Abrasion of intricate details causes a rounding of sharp corners and other loss of delicate features, while abrasion of polished surfaces removes the polished quality of stone. Mechanical methods, therefore, should never be used on these surfaces and should be used with extreme caution on others.

Grit blasting, unfortunately, still is widely used in spite of these serious effects. In most cases, blasting will leave

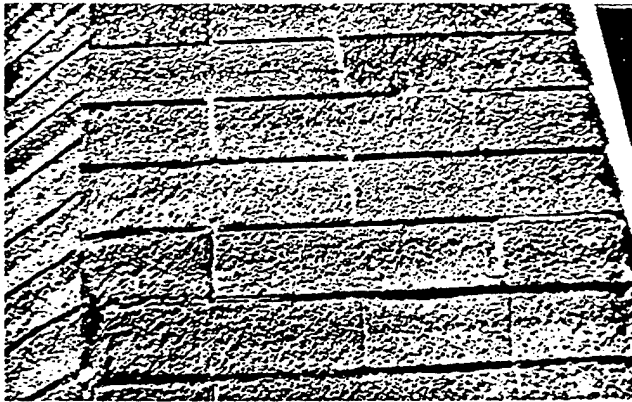

Figure 5. This brickwork was sandblasted to remove paint. Note the severe erosion which has occurred, especially in the softer center sections of this "hard burned" late 19th-century brick. Although this is a severe example, the same problem of increased roughness and porosity will occur even on more skillfully performed jobs where the effect is less evident visually.

minute pits on the surface of the masonry. This additional roughness actually increases the surface area on which new dirt can settle and on which pollutants can react.

Mortar joints, especially those with lime mortar, also can be eroded by mechanical cleaning. In some cases, the damage may be visual, such as loss of joint detail or increased joint shadows. Joints constitute a significant portion of the masonry surface (up to 20% in a brick wall) so this change should not be considered insignificant. In other cases, however, the erosion of the mortar joint may permit increased water penetration, leading to the necessity for complete repointing.

Other problems of mechanical methods have been mentioned in the discussion of project planning. In addition, wet blasting or water rinses can create the potential hazards of water methods.

Problems Of Water Repellent And Waterproof Coatings

Is waterproofing necessary? Coatings frequently are applied to historic buildings without concern for the requirement or the consequences of the coating. Most historic buildings have survived for years without coatings, so why are they needed now? Water penetration to the interior usually is not caused by porous masonry but by deteriorated gutters and downspouts, deteriorated mortar, capillary moisture from the ground (rising damp), or condensation. Coatings will not solve these problems. In the case of rising damp, in fact, the coatings will allow the water to go even higher because of the retarded rate of evaporation. The claim also is made that coatings keep dirt and pollutants from collecting on the surface of the building thus reducing the requirement for future cleaning. While this at times may be true, at other times the coatings actually retain the dirt more than uncoated masonry. More important, however, is the fact that these coatings can cause greater deterioration of the masonry than that caused by pollution, so the treatment may be worse than the problem one is attempting to solve.

Types of coatings: Masonry coatings are of two types: *waterproof* coatings and *water repellent* coatings. Waterproof coatings seal the surface from liquid water and from water vapor; they usually are opaque, such as bituminous coatings and some paints. Water repellents keep liquid water from penetrating the surface but allow water vapor to enter and leave through the "pores" of the masonry. They usually are transparent, such as the silicone coatings, although they may

change the reflective property of the masonry, thus changing the appearance.

Waterproof coatings: These coatings usually do not cause problems as long as they exclude *all* water from the masonry. If water does enter the wall, however, the coating can intensify the damage because the water will not be able to escape. During cold weather this water in the wall can freeze, causing serious mechanical disruption, such as spalling. In addition, the water eventually will get out by the path of least resistance. If this path is toward the interior, damage to interior finishes can result; if it is toward exterior cracks in the coating, it can lead to damage from the build-up of salts as described below.

Water repellent coatings: These coatings also can cause serious damage, but by a somewhat different mechanism. As water repellent coatings do not seal the surface to water vapor, it can enter the wall as well as leave the wall. Once inside the wall, the vapor can condense at cold spots, producing liquid water. Water within the wall, whether from condensation, leaking gutters, or other sources, can do damage, as explained earlier.

Further damage can be done by soluble salts. Salts frequently are present in the masonry, either from the mortar or from the masonry units themselves. Liquid water can dissolve these salts and carry them toward the surface. If the water is permitted to come to the surface, efflorescences appear upon evaporation. These are unsightly but usually are easily removed; they often are washed away by the simple action of the rain.

The presence of a water repellent coating, however, prevents the water and dissolved salts from coming completely to the surface. The salts then are deposited slightly behind the surface of the masonry as the water evaporates through the pores. Over time, the salt crystals will grow and will develop substantial pressures which will spall the masonry, detaching it at the depth of crystal growth. This build-up may take several years to cause problems.

Test patches for coatings generally do not allow an adequate evaluation of the treatment, because water may enter and leave through the surrounding untreated areas, thus flushing away the salt build-up. In addition, salt deposits may not cause visible damage for several years, well after the patch has been evaluated.

This is not to suggest that there is never a use for water repellents or waterproofings. Sandblasted brick, for example, may have become so porous that paint or some type of coating is essential. In other cases, the damage being caused by local pollution may be greater than the potential damage from the coatings. Generally, coatings are not necessary, however, unless there is a specific problem which they will help to solve. If the problem occurs on only a portion of the masonry, it probably is best to treat only the problem area rather than the entire building. Extreme exposures such as parapets, for example, or portions of the building subject to driving rains can be treated more effectively and less expensively than the entire building.

This publication was prepared pursuant to Executive Order 11593, "Protection and Enhancement of the Cultural Environment," which directs the Secretary of the Interior to "develop and make available to Federal agencies and State and local governments information concerning professional methods and techniques for preserving, improving, restoring and maintaining historic properties." The Brief has been developed under the technical editorship of Lee H. Nelson, AIA, Chief, Preservation Assistance Division, National Park Service, U.S. Department of the Interior, Washington, D.C. 20240. Comments on the usefulness of this information are welcome and can be sent to Mr. Nelson at the above address. This publication is not copyrighted and can be reproduced without penalty. Normal procedures for credit to the author and the National Park Service are appreciated. November 1975.

U.S. Department of the Interior

National Park Service
Preservation Assistance Division
Technical Preservation Services

Preservation Briefs: 2

Repointing Mortar Joints in Historic Brick Buildings

Robert C. Mack, AIA
de Teel Patterson Tiller
James S. Askins

Repointing is the process of removing deteriorated mortar from the joints of a masonry wall and replacing it with new mortar. Properly done, repointing restores the visual and physical integrity of the masonry. Improperly done, repointing not only detracts from the appearance of the building, but may, in fact, cause physical damage to the masonry units themselves.

The purpose of this brief is to provide general guidance on appropriate materials and methods for repointing historic brick buildings and is intended to benefit building owners, architects, and contractors alike. Because of its general nature, this publication should not be considered a specification for repointing. Rather, it should serve as a guide to prepare such specifications; to develop sensitivity to the particular needs of historic masonry; and to assist historic building owners in working cooperatively with contractors and architects.

Identifying the Problem

The decision to repoint is most often related to some obvious sign of deterioration (figure 1) such as disintegrating mortar, cracks in mortar joints, loose bricks, damp walls, or damaged plasterwork. It is, however, erroneous to assume that repointing alone will solve all these problems. Therefore, the true cause of the deterioration should be determined before beginning any repointing work. Leaking roofs or gutters, differential settlement of the building, capillary action causing rising damp, or extreme weather exposure should all be recognized as sources of deterioration and should be dealt with immediately. Without such action, mortar deterioration will continue and any repointing work will have been a waste of time and money.

Budgeting and Scheduling

It is important to recognize that repointing will probably be both expensive and time-consuming due to the extent of handwork and special materials required; however, it should also be emphasized that it is not only possible, but preferable to repoint *only* those areas that require work rather than an entire wall, as is often specified. Recognizing this at the outset may prevent many restoration/rehabilitation jobs from becoming prohibitively expensive.



Figure 1. All buildings and building materials are in a constant process of deterioration, such as the brick masonry seen here. Through repointing, the deteriorated mortar joints which might otherwise lead to serious damage, can be renewed and thus preserve the historic character and integrity of the brickwork. Photo: Baird M. Smith.

In scheduling, seasonal aspects need to be considered first. Generally speaking, repointing should only be undertaken when the wall temperatures are between 40° and 95° (F) to prevent freezing or excessive evaporation of the water in the mortar. During hot weather, repointing should ideally be done on the shady side of the building in order to slow the drying process of the mortar.

The relationship of repointing to other proposed work on the building must also be recognized. For example, if paint removal or cleaning are anticipated and if the mortar joints are basically in sound condition and only need selective repointing, it is generally better to postpone repointing until after completion of these activities. However, if the mortar has badly eroded, thus allowing moisture to penetrate deeply into the wall, repointing should be accomplished before cleaning. Related work such as structural or roof repairs should be scheduled so that they do not interfere with repointing and so that all work can take maximum advantage of scaffolding.

Visual Examination

All repointing work on historic masonry buildings should be preceded by an analysis of the mortar and by an examination of the bricks and the techniques used in the original construction of the wall. For most projects, a simple visual analysis of the historic mortar is sufficient to allow an appropriate match for the new mortar. The exact physical and chemical properties of the historic mortar are not of major significance as long as the new mortar:

- matches the historic mortar in color, texture, and detailing;
- is softer (measured in compressive strength) than the brick;
- is as soft, or softer (measured in compressive strength) than the historic mortar.

A simple method of analyzing the historic mortar to aid in developing an appropriate repointing mortar for many restoration jobs and most rehabilitation work follows¹:

- 1) Remove three or four unweathered samples of the mortar to be matched from several locations on the building (set the largest sample aside—this will be used later for comparison with the repointing mortar). It is important to recognize that many historic buildings have been repointed a number of times and that on any given wall surface there may be a variety of mortars. Therefore, it is important to remove as many samples as are representative to obtain a "mean" mortar sample.
- 2) Break the remaining samples apart with a wooden mallet until they are separated into their constituent parts. There should be a good handful of the material.
- 3) Carefully blow away the powdery material (the lime or cement matrix which bound the mortar together).
- 4) With a low power (10 power) magnifying glass, examine the remaining sand and other materials such as oyster shells.
- 5) Note and record the wide range of color as well as the varying sizes of the individual grains of sand or shell.

Historic sand colors may range from white to grey to yellow within a given mortar sample. Furthermore, the varying sizes of the grains of sand or other materials such as shell play an important role in the texture of the repointing mortar. Historic sand was not screened or graded by size as it is today. Therefore, when specifying sand for repointing mortar, consideration may need to be given to obtaining sand from several sources and then combining them in order to approximate the range of sand colors and grain sizes in the historic mortar sample. The role of the sand in the overall appearance of the replacement mortar should not be underestimated!

Pointing styles and the methods of producing them should be examined (figure 2). It is important to look at both the horizontal and the vertical joints to determine the order in which they were tooled and whether they

were the same style. Some late-19th- and 20th-century buildings, for example, have horizontal joints that were tooled while the vertical joints were finished flush and stained to match the bricks, thus creating the illusion of horizontal bands. It is significant to note that pointing styles often differed from one facade to another. Front walls often received greater attention to mortar detailing than side and rear walls.

Bricks should also be examined so that any replacement will match the historic brick. Within a wall there may be a surprising range of colors, textures, and sizes, particularly with hand-made brick. Replacement should match the full range of the historic brick rather than a single brick. Although many bricks can be matched from existing stock, they must often be custom-ordered, a lengthy process that can seriously affect the project budget and schedule. Here, there should be a note of caution! The use of recycled brick from demolished buildings for replacement brick often results in an excellent color and texture match; however, it is important to remember that historic brick was manufactured in varying grades, ranging from high-fired exterior brick to low-fired interior "bat" or "clinker" brick. This low-fired brick was never intended to be exposed to the weather, and, when used for replacement brick on an exterior wall, will deteriorate at a rapid rate, often needing replacement within a year or two. Great care, therefore, should be taken in choosing the proper type of recycled brick.

Properties of Mortar

In general, mortars for repointing should be softer (measured in compressive strength) than the masonry units and no harder than the historic mortar. This is necessary to prevent damage to the masonry units. It is a common error to assume that hardness or high strength is a measure of durability. Stresses within a wall caused by expansion, contraction, moisture migration, or settlement must be accommodated in some manner; in a masonry wall, these stresses should be relieved by the mortar rather than by the bricks. A mortar that is stronger or harder than the bricks will not "give," thus causing the stresses to be relieved through the bricks—resulting in cracking and spalling (figure 3). Stresses can also break the bond between the mortar and the brick, permitting water to penetrate the resulting hairline cracks.

Constituents of Mortar

Sand: Sand is the largest constituent of mortar and the material that gives mortar its characteristic color and texture. When viewed under a magnifying glass or low-power binocular microscope, particles of sand generally have either rounded edges, such as found in beach or river sand, or sharp, angular edges, found in crushed or manufactured sand. For repointing mortar, rounded or natural sand is preferred for two reasons. First, it is usually similar to the sand in the historic mortar, thus providing a better visual match. Second, it has better "working" qualities or plasticity and can thus be forced into the joint more easily, forming a good contact with the historic mortar and the surface of the bricks. Although manufactured sand is frequently the only type readily available, it is worth the search to locate a sufficient quantity of rounded or natural salt-free sand for repointing.

¹ Two detailed methods for performing a mortar analysis are presented by E. Blaine Cliver in "Tests for the Analysis of Mortar Samples" in the *Bulletin of the Association for Preservation Technology*, vol. 6 (no. 1, 1974); and Morgan W. Phillips in "Brief Notes on the Subjects of Analyzing Paints and Mortar and the Recording of Moulding Profiles: The Trouble with Paint and Mortar Analysis" in the *Bulletin of the Association for Preservation Technology*, vol. 10 (no. 2, 1978).

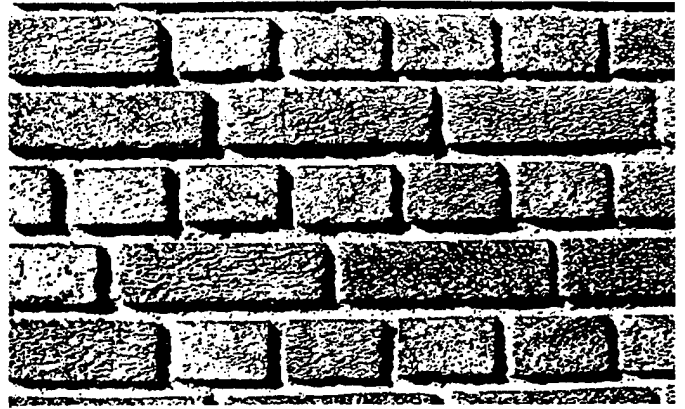

Figure 2. Joint styles and bonding patterns give a rich, divergent, and varied character to historic masonry walls as is apparent in these two examples. The sample on the left is an 18th century (c. 1720) Flemish bond struck with a grapevine joint; the example on the right, an early 20th century English bond with a raked joint. Successfully recreating the historically correct joint size and profile is of paramount importance in the appropriate repointing of historic brick walls. Photos: Calder Loth.

Lime or Portland Cement: The two commonly used binders for mortar are lime and portland cement. Of the two, lime produces a mortar that meets nearly all the requirements for a good mortar for historic buildings, while portland cement produces a mortar that does not perform as well. High lime mortar is soft, porous, and changes little in volume during temperature fluctuations. In addition, lime mortar is slightly water soluble and thus is able to re-seal any hairline cracks that may develop during the life of the mortar. Portland cement, on the other hand, can be extremely hard, is resistant to movement of water, shrinks upon setting, and undergoes relatively large thermal movements. The use of a high lime mortar, therefore, is recommended for nearly all repointing projects. *However, white portland cement can be substituted for up to 20 percent of the lime (ex. 1 part cement to 4 parts lime). This will usually improve workability or plasticity without adversely affecting the desirable qualities of the lime mortar.* Plasticity is important to ensure a good bond between the new mortar, the historic mortar, and the brick.

Water: Water should be clean and relatively free of salts or acids.

Historic Additives: In addition to the color of the sand, the texture of the mortar is of critical importance in duplicating historic mortar. While modern mortars are finely ground and present a uniform texture and color, historic mortars were not as well ground. They may contain lumps of oyster shell, partially burned lime, animal hair, or particles of clay. The visual characteristics of these additives should be duplicated through the use of similar materials in the repointing mortar.

Matching Color and Texture of Mortar

In matching the repointing mortar, the new mortar should match the unweathered interior portions of the historic mortar. The simplest way to check the match is to make a small sample of the proposed mix and allow it to cure; this sample is then broken open and the broken surface is compared with the broken surface of the largest "saved" sample of historic mortar.

If it is not possible to obtain a proper color match through the use of natural materials because locally available sands are not a close match to the original sand, it may be necessary to use a modern mortar pig-

ment, and, in fact, some historic mortars did use such additives. In the late 19th century, some mortars were colored with pigments to match or contrast with the brick. Red, brown, and black pigments were commonly used. Pigments are available as separate ingredients or already mixed with mortar; however, the premixed mortars normally are not suited for use on repointing projects because of their high portland cement content. Only chemically pure mineral oxides, which are alkali-proof and sun-fast, should be used in order to prevent bleaching and fading.

Material Specifications

Modern materials specified for use in repointing mortar should conform to specifications of the American Society for Testing Materials (ASTM) or comparable federal specifications.

Sand should conform to ASTM C-144 to assure proper gradation and freedom from impurities. Sand color, size, and texture should match the original as closely as possible to provide the proper color match without other additives. Samples of sand proposed for use should be submitted for approval prior to beginning work.

Lime should conform to ASTM C-207, Type S, Hydrated Lime for Masonry Purposes. This lime is designed to assure high plasticity and water retention with a safe degree of strength. The use of quicklime, which must be slaked and soaked, does not necessarily provide better results.

Cement should conform to ASTM C-150, Type II (white non-staining) portland cement. It should not have more than 0.60 percent alkali to help avoid efflorescence.

Water should be potable—clean and free from acids, alkalies, or large amounts of organic materials.

Historic Additives will require writing new specifications for each project. If possible, suggested sources for special materials should be included. For example, crushed oyster shells frequently can be obtained in a variety of sizes from poultry supply dealers.

Mortar Mix: Specifying the proportions for the repointing mortar for a specific job is often a perplexing task for the architect, engineer, contractor, or preservation

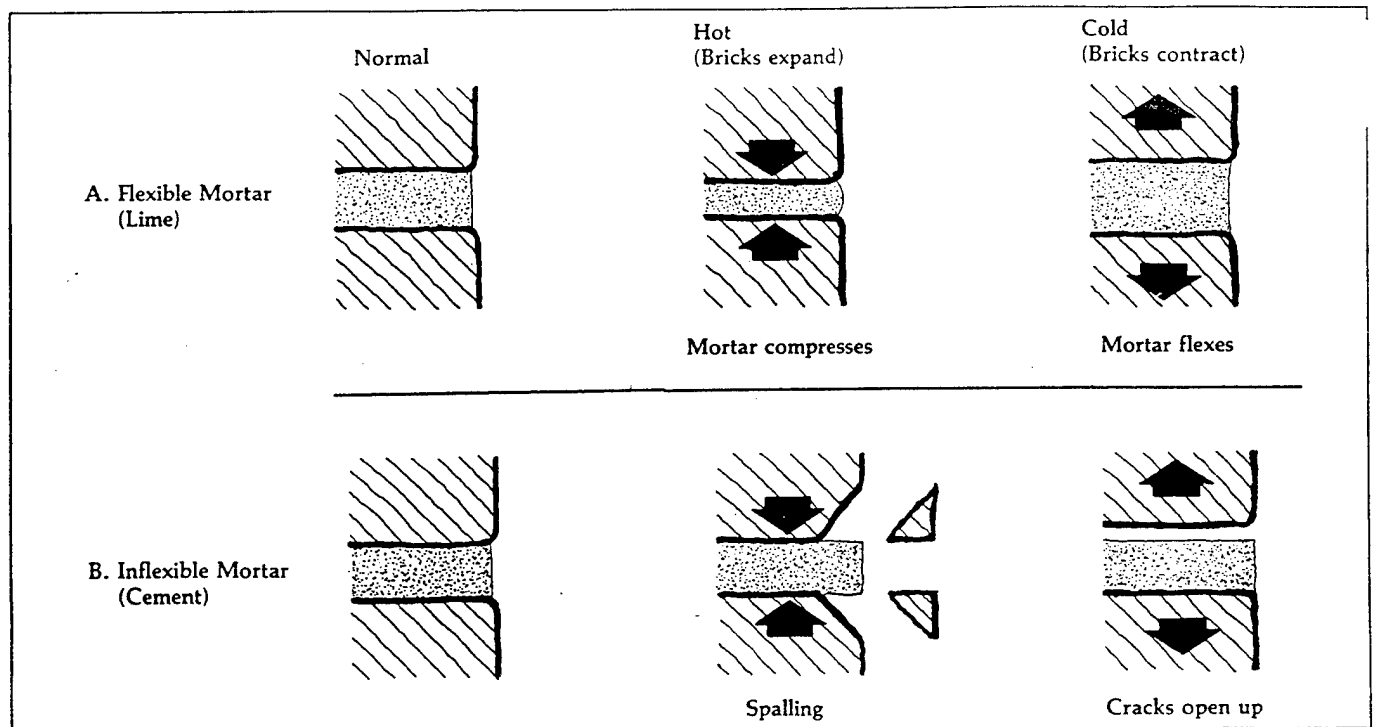

Figure 3. Diagrammatic sketches showing effects of temperature change upon masonry. Flexible mortar (A) expands and contracts with temperature changes. Bricks bonded by inflexible mortar (B) tend to spall at the edges (the area of greatest stress) in hot weather and separate from the mortar when it is cold. This latter condition opens cracks, permitting the entry of water and causing additional deterioration. Adapted from Maintenance of Old Buildings, Document D10; National Swedish Institute for Building Research, Stockholm, 1975.

consultant alike. The following guidelines can assist in writing specifications:

- Material proportions should be given in volumes, that is, 4 parts of lime to 12 parts of sand, rather than 2 bags of lime to 6 cubic feet of sand. This will avoid any confusion on the job site when substitution of sources occur with differing packaging sizes.
- Repointing mortar for most historic buildings should ideally be composed only of lime and sand. A proportion of 1 part of lime to 2 parts of sand is a useful starting point.
- ASTM C-150, Type II (white non-staining) portland cement may be added to the repointing mortar to increase workability and to achieve whiteness in color; however, no more than 20 percent of the total volume of the lime and portland cement—combined—should be portland cement. Any greater amount of portland cement increases the hardness of the repointing mortar to a potentially damaging degree.
- For surfaces of extreme weather such as parapet walls or water tables, a harder mortar (6 parts of sand, to 3 parts of lime, to 2 parts of white portland cement) may be more desirable.

Execution of the Work

The Test Panel: In choosing a contractor or mason, perhaps the best way to award the contract and for the contractor or mason to demonstrate his or her work in a repointing job is the test panel: a small demonstration section of joint preparation and repointing actually done on the historic masonry. The test panel should be carefully selected to include all types of masonry, joint styles, and types of problems to be encountered on the

job. Usually a 3-foot by 6-foot area located in an inconspicuous yet readily accessible place is sufficient.

Joint Preparation: Old mortar should generally be removed to a minimum depth of $2\frac{1}{2}$ times the width of the joint to ensure an adequate bond and to prevent mortar "popouts." For most brick joints, this will require removal of the mortar to a depth of approximately $\frac{1}{2}$ -1 inch. Any loose or disintegrated mortar beyond this minimum depth should be removed (figure 4). The use of power tools such as saws with carbide blades or impact hammers for the removal of mortar almost always results in damage to the bricks by breaking the edges and by overcutting on the head, or vertical, joints (figure 5). Damage to the bricks not only affects their visual character but can also lead to accelerated weather damage. Where joints are uniform and fairly wide, it may be possible to use a grinder to assist the removal of mortar; however, final preparation of the joint should be done by hand.

Test panels are quite helpful, but they cannot adequately assess the potential effect of using a grinder since such panels are not prepared under actual working conditions. If there is any chance of damaging the masonry, hand-methods should be used exclusively. Although slower, these methods are easier to control and less likely to cause irreversible damage to the bricks. Mortar should be removed cleanly from the bricks, leaving square corners at the back of the cut. Before filling, the joints should be rinsed with a jet of water to remove all loose particles and dust. At the time of filling, the joint should be damp but with no standing water present.

Mortar Preparation: Mortar should be mixed carefully to obtain uniformity of visual and physical characteristics.

Dry ingredients should be measured by volume and thoroughly mixed before the addition of any water. Half the water should be added, followed by mixing for approximately 5 minutes. The remaining water should then be added in small portions until a mortar of the desired consistency is reached. The total volume of water necessary may vary from batch to batch, depending on weather conditions. Mortar should be used within 30 minutes of final mixing, and "re-tempering," or adding more water after the initial mix is prepared, should not be permitted.

Modern Additives: In general, modern chemical additives are unnecessary and may, in fact, have detrimental effects. The use of antifreeze compounds is not recommended. They are not very effective with high lime mortars and may introduce salts, which will later cause efflorescence. A better practice is to warm the sand and water, and to protect the completed work from freezing. The use of air-entraining additives to resist frost action and enhance plasticity, are also discouraged, since the air has a detrimental effect on both bond and strength of the mortar. In areas of extreme exposure requiring high-strength mortars (see formula for "extreme weather exposure" under *Mortar Mix* section), air-entrainment of 10-16 percent may, however, be desirable. Bonding agents that increase the bond of the new mortar to the old should also be avoided. If the joint is properly prepared, there will be a good bond between the new mortar and the adjacent surfaces; chemical agents do not significantly improve this bond and are not a substitute for proper joint preparation. In addition, some of the agent will inevitably become smeared on the surface of the masonry and removal is very difficult.

Filling the Joint: Where existing mortar has been removed to a depth of greater than 1 inch, these deeper areas should be filled first, compacting the new mortar in several layers. The back of the entire joint should be filled successively by applying approximately ¼ inch of mortar, packing it well into the back corners. This application may extend for several feet. As soon as the mortar has reached thumb-print hardness, another ¼ inch layer of mortar—approximately the same thickness—may be applied. Several layers will be needed to fill the joint flush with the outer surface of the brick. It is important to allow each layer time to harden before the next layer is applied; most of the mortar shrinkage occurs during the hardening process and layering thus minimizes overall shrinkage.

The rate of hardening can be controlled by dampening the brick and the old mortar before beginning to fill the joint, but free water or excessive dampness in the joint should be avoided. Too much water will delay the tooling or cause excess shrinkage; too little water will be absorbed from the mortar before it is properly set, thus reducing bond strength.

When the final layer of mortar is thumb-print hard, the joint should be tooled to match the historic joint. Proper timing of the tooling is important for uniform color and appearance. If tooled when too soft, the color will be lighter than expected, and hairline cracks may occur; if tooled when too hard, there may be dark streaks called "tool burning," and good closure of the mortar against the brick will not be achieved.

If the old bricks have worn, rounded edges, it is usually best to recess the final mortar slightly from the face of the bricks. This treatment will help avoid a joint visually wider than the actual joint width; it will also avoid creation of a large, thin featheredge which is easily damaged, thus admitting water (figures 6 and 7).

After tooling, it is frequently necessary to remove excess mortar from the edge of the joint by brushing with a bristle brush.

"Aging" the Mortar: Even with the best efforts at matching the existing mortar color, texture, and materials, there will usually be a visible difference between the old work and the new, partly because the new mortar has been matched to the unweathered portions of the historic mortar. If the mortars have been properly matched, the best treatment for surface color differences is to let the mortars age naturally. Another reason for a slight mismatch may be that the sand is more exposed in old mortar due to the slight erosion of the lime or cement. Several methods of treatment have been attempted in an effort to overcome these differences. As with all work, however, any proposed treatment should be carefully tested prior to implementation.

Efforts to stain the new mortar to produce a color match should, in most cases, be avoided. Although such a process may provide an initial match, the old and new mortars may weather at different rates, leading to visual differences after a few seasons. In addition, the mixtures used to stain the mortar may be harmful to the masonry, for example, introducing salts into the masonry which can lead to efflorescence.

Cleaning: If repointing work is carefully executed, there will be little need for cleaning other than the small

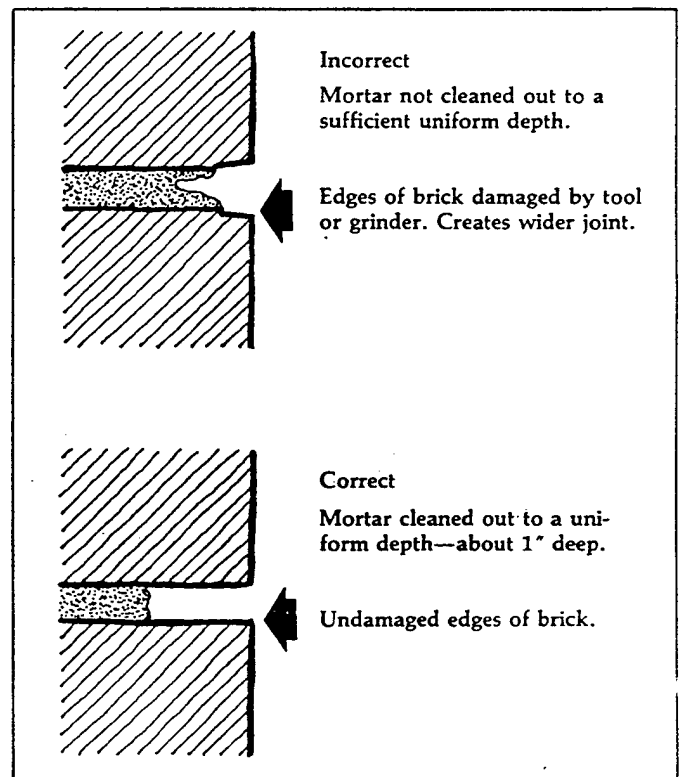

Figure 4. Comparison of incorrect and correct preparation of mortar joints for repointing. Drawing: Robert C. Mack and David W. Look.

amount of mortar brushed from the edge of the joint following tooling. This type of cleaning is best accomplished with a stiff bristle brush after the mortar has dried, but before it is fully hardened (1-2 hours). Mortar that has hardened can usually be removed with a wooden paddle or, if necessary, a chisel.

Further cleaning is best accomplished with plain water and bristle brushes. If chemicals must be used, their selection should be made with extreme caution. Improper cleaning can lead to deterioration of the masonry units, deterioration of the mortar, mortar smear, and efflorescence. New mortar joints are especially susceptible to damage because they do not become fully cured for several months. Chemical cleaners, particularly acids, should be used only once and should be flushed freely with plain water to remove all traces of the chemicals.

Several precautions should be taken if freshly re-pointed mortar joints are being cleaned. First, the mortar should be fully hardened before cleaning—30 days is usually sufficient, depending on weather and exposure (as mentioned above, the mortar will continue to cure even after the mortar has hardened). Test panels should be prepared to evaluate the effects of different cleaning methods. Only stiff natural bristle brushes should be used, except on glazed or polished surfaces. Here, only soft cloths should be used. Further information concerning masonry cleaning is presented in Preservation Briefs 1 "The Cleaning and Waterproof Coating of Masonry Buildings."

New construction "bloom" or efflorescence occasionally appears within the first few months of re-pointing and usually disappears through the normal process of weathering. If the efflorescence is not removed by natural processes, the safest way to remove it is by dry brushing with stiff natural or nylon bristle brushes and water. Hydrochloric (muriatic) acid, is generally ineffective and should be avoided in the removal of efflorescence. In fact this chemical may deposit additional salts, which, in turn, can lead to additional efflorescence.

Scrub Coats: A variety of new and purportedly useful re-pointing techniques for historic buildings are being offered by contractors which, appear to have limited usefulness in historic preservation. These techniques are identified under a variety of names that include: slurr coats, slurry coating, and, most commonly, scrub coating. All involve the brushing of a thinned, low-aggregate coat of mortar over the entire masonry surface which, when dry, is scrubbed off the brick with a brush, presumably leaving a residue in the mortar joint. These techniques have become increasingly appealing as they are quick, inexpensive in comparison to traditional re-pointing costs, and do not require particularly skilled labor or craftsmanship. Their greatest attraction lies in re-pointing large masonry surfaces such as highrise structures, but their benefit to historic masonry is essentially cosmetic. A certain amount of crack sealing in the mortar joint does occur, and for these limited applications it is a useful technique; however, these techniques should not be confused with, or substituted for, re-pointing. It is not the same process. Slurr coats and slurry and scrub coatings, tend to mask joint detailing or tooling, have a life expectancy of only a few years, and are extremely difficult to clean from the surface of the brick without leaving a residue, called "veiling." While of some limited use in specific instances, these new techniques are not

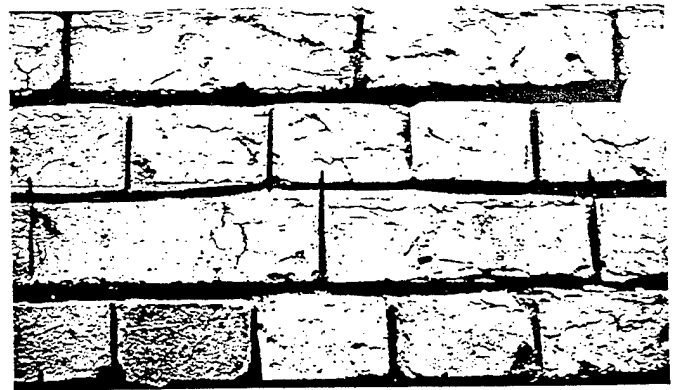

Figure 5. The damage to these bricks was caused by using a power saw with a carbide blade to rake out the mortar joints. Note the overcutting of the joint into the brick above the vertical joint. Careful hand work is required to prevent such damage to the brick during joint preparation. Photo: John Myers.

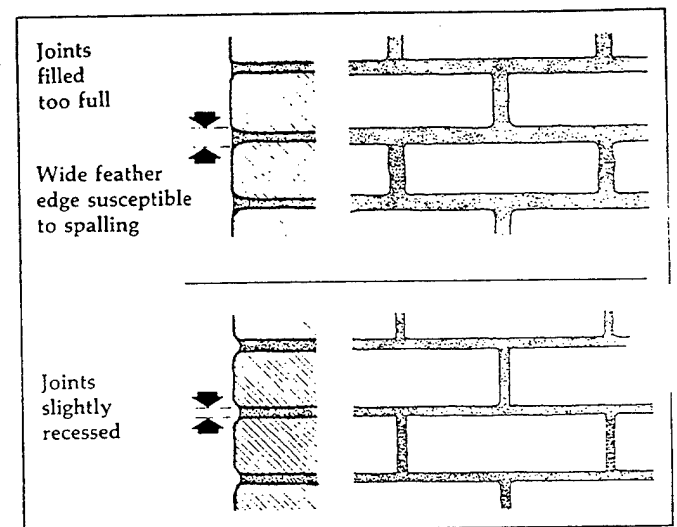

Figure 6. Comparison of visual effect of full mortar joints vs slightly recessed joints. Filling joints too full hides the actual joint thickness and changes the character of the original brickwork.



Figure 7. This photograph shows the significant visual change which can result from improper re-pointing procedures. Note the increased thickness of the joints, the color variation, and the difference in the method of tooling—all noticeable even from a distance. Photo: Ler Nelson.

appropriate for historic buildings and should therefore not be considered when a lasting and durable repointing job is desired.

Summary

For the Owner/Administrator: The owner or administrator of an historic building must constantly remember that repointing is likely to be a lengthy and expensive process. The owner will need to allow adequate time for evaluation by a qualified preservationist, for preparation of plans and specifications for the work, and for a lengthy work period with scaffolding in place. Schedules for both repointing work and other activities will thus require careful coordination to avoid unanticipated conflicts. The owner must avoid the tendency to rush the work or economize if the building is to retain its visual integrity and the job is to be durable.

For the Architect/Consultant: The architect/consultant must assist the owner in planning for logistical problems relating to research and construction. The consultant must also realize that older buildings have special problems usually not encountered with modern building materials or techniques of construction. Therefore, extra research will be required, and nonstandard materials and procedures will need to be used in evaluating the work of potential contractors to ensure that they are qualified to work on projects of the type anticipated. The consultant must also be prepared to spend more time than is customary in modern construction to inspect the work.

For the Contractor/Craftsman: The contractor or craftsman must keep in mind that a repointing project for a historic building will be slower and more expensive per unit cost than work on a modern building. The contractor must understand the reasons for these special requirements, and must convey them to the workers at all levels. Understanding the nature of the project and the potential problems will not only allow the contractor to submit a more accurate bid, but will also provide for the use of nonstandard methods in performing work.

Conclusion

First and foremost, a good repointing job is meant to last, often in the range of 50-100 years. Shortcuts and poor craftsmanship not only result in a job that looks bad, but also in one that will require future repointing more frequently than if the job had been done correctly in the first place. The mortar joint in a historic brick building has often been called the wall's "first line of defense." Good repointing practices guarantee the long life of the mortar joint, the wall, and the historic structure. However, while careful preservation, restoration, and maintenance will guarantee the long life of the freshly repointed mortar joints, it is important to remember that these mortar joints will probably require repointing some time in the future. It is the nature of mortar joints to deteriorate. Nevertheless, if the historic mortar joints proved durable for many years, then careful repointing should have an equally long life, ultimately contributing to the preservation of the historic brick building.

This brief was first written by Robert C. Mack, AIA, in 1976. It has been revised and updated in 1980 by Robert

C. Mack, de Teel Patterson Tiller, Architectural Historian, Heritage Conservation and Recreation Service (HCRS), Department of the Interior; and James S. Askins, Preservation Craftsman, National Park Service, Department of the Interior. Other HCRS staff members who contributed materially to the development of this revised brief are Kay D. Weeks, Technical Writer-Editor, and James A. Caufield, Historical Architect.

September 1980

This publication was prepared pursuant to Executive Order 11593, "Protection and Enhancement of the Cultural Environment," which directs the Secretary of the Interior to "develop and make available to Federal agencies and State and local governments information concerning professional methods and techniques for preserving, improving, restoring and maintaining historic properties." The Brief has been developed under the technical editorship of Lee H. Nelson, AIA, Chief, Preservation Assistance Division, National Park Service, U.S. Department of the Interior, Washington, D.C. 20240. Comments on the usefulness of this information are welcome and can be sent to Mr. Nelson at the above address. This publication is not copyrighted and can be reproduced without penalty. Normal procedures for credit to the author and the National Park Service are appreciated.

Selected Reading List

- Brick Institute of America. "Cleaning Brick Masonry" *Technical Notes on Brick Construction* (no. 20) rev., Sept/Oct., 1977.
- Cliver, E. Blaine. "Tests for the Analysis of Mortar Samples," *Bulletin of the Association for Preservation Technology*, vol. 6 (no. 1, 1974), pp. 68-73.
- Mack, Robert C. "The Cleaning and Waterproof Coatings of Masonry Buildings," *Preservation Briefs: 1, Heritage Conservation and Recreation Service*, Washington, D.C., November 1975.
- Mack, Robert C., and Askins, James S. "The Repointing of Historic Masonry Buildings," *Downer Grove*, Illinois, Service Master Industries, 1979.
- McKee, Harley J. "Brick and Stone: Handicraft to Machine," *Building Early America*. The Carpenters' Company of the City and County of Philadelphia, 1976.
- McKee, Harley J. *Introduction to Early American Masonry*. Washington, D.C.: National Trust for Historic Preservation/Columbia University, 1973.
- Phillips, Morgan. "SPNEA-APT Conference on Mortar," *Bulletin of the Association for Preservation Technology*, vol. 6 (no. 1, 1974).

3 PRESERVATION BRIEFS

Conserving Energy in Historic Buildings

Baird M. Smith, AIA

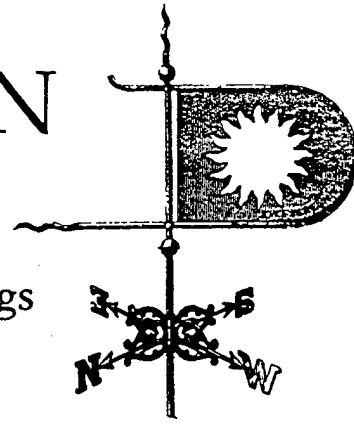

U.S. Department of the Interior National Park Service
Preservation Assistance Division Technical Preservation Services

With the dwindling supply of energy resources and new efficiency demands placed on the existing building stock, many owners of historic buildings and their architects are assessing the ability of these buildings to conserve energy with an eye to improving thermal performance. This brief has been developed to assist those persons attempting energy conservation measures and weatherization improvements such as adding insulation and storm windows or caulking of exterior building joints. In historic buildings, many measures can result in the inappropriate alteration of important architectural features, or, perhaps even worse, cause serious damage to the historic building materials through unwanted chemical reactions or moisture-caused deterioration. This brief recommends measures that will achieve the greatest energy savings with the least alteration to the historic buildings, while using materials that do not cause damage and that represent sound economic investments.

Inherent Energy Saving Characteristics of Historic Buildings

Many historic buildings have energy-saving physical features and devices that contribute to good thermal performance. Studies by the Energy Research and Development Adminis-

tration (see bibliography) show that the buildings with the poorest energy efficiency are actually those built between 1940

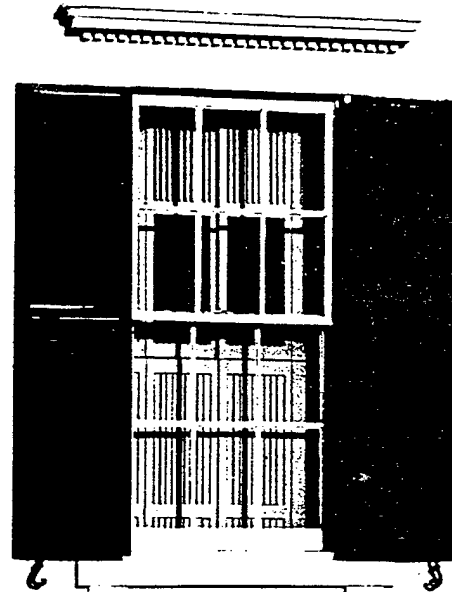

Figure 2. Shutters can be used to minimize the problem of summer heat gain by shading the windows. If operable shutters are in place, their use will help reduce the summer cooling load. (Photo: Baird Smith)

and 1975. Older buildings were found to use less energy for heating and cooling and hence probably require fewer weatherization improvements. They use less energy because they were built with a well-developed sense of physical comfort and because they maximized the natural sources of heating, lighting and ventilation. The historic building owner should understand these inherent energy-saving qualities.

The most obvious (and almost universal) inherent energy saving characteristic was the use of *operable windows* to provide natural ventilation and light. In addition, historic commercial and public buildings often include interior light/ventilation courts, roof-top ventilators, clerestories or skylights (see figure 1). These features provide energy efficient fresh air and light, assuring that energy consuming mechanical devices may be needed only to supplement the natural energy sources. Any time the mechanical heating and air conditioning equipment can be turned off and the windows opened, energy will be saved.

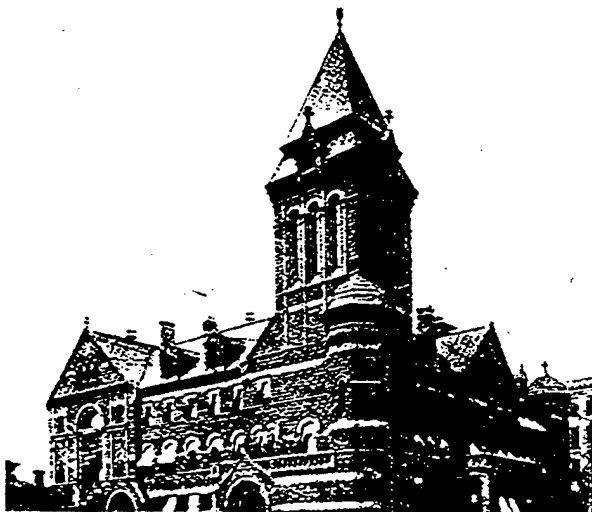

Figure 1. This 1891 Courthouse and Post Office in Rochester, New York, has built-in energy conserving features such as, heavy masonry walls, operable windows, an interior skylighted atrium which provides light and ventilation, and roof-top ventilators which keep the building cooler in the summer. Also note the presence of awnings in this old photograph.



Figure 3. Southern mansions typify climate conscious design. The wide roof overhangs, exterior porches, shade trees, heavy masonry walls (painted white), and living quarters on the second floor (to catch evening breezes and escape the radiant heat from the earth's surface) all are energy saving characteristics which provide reasonably comfortable living spaces without mechanical air conditioning. (Photo: Marcia Axtmann Smith)

Early builders and architects dealt with the poor thermal properties of windows in two ways. First, the number of windows in a building was kept to only those necessary to provide adequate light and ventilation. This differs from the approach in many modern buildings where the percentage of windows in a wall can be nearly 100%. Historic buildings, where the ratio of glass to wall is often less than 20%, are better energy conservers than most new buildings. Secondly, to minimize the heat gain or loss from windows, historic buildings often include interior or exterior shutters, interior venetian blinds, curtains and drapes, or exterior awnings (see figure 2). Thus, a historic window could remain an energy efficient component of a building.

There are other physical characteristics that enable historic buildings to be energy efficient. For instance, in the warmer climates of the United States, buildings were often built to minimize the heat gain from the summer sun. This was accomplished by introducing exterior balconies, porches, wide roof overhangs, awnings and shade trees. In addition, many of these buildings were designed with the living spaces on the second floor to catch breezes and to escape the radiant heat from the earth's surface. Also, exterior walls were often painted light colors to reflect the hot summer sun, resulting in cooler interior living spaces (see figure 3).

Winter heat loss from buildings in the northern climates was reduced by using heavy masonry walls, minimizing the number and size of windows, and often using dark paint colors for the exterior walls. The heavy masonry walls used so typically in the late 19th century and early 20th century, exhibit characteristics that improve their thermal performance beyond that formerly recognized (see figure 4). It has been determined that walls of large mass and weight (thick brick or stone) have the advantage of *high thermal inertia*, also known as the "M factor." This inertia modifies the thermal resistance (R factor)* of the wall by lengthening the time scale of heat transmission. For instance, a wall with high thermal inertia, subjected to solar radiation for an hour, will absorb the heat at its outside surface, but transfer it to the interior over a period as long as 6 hours. Conversely, a wall having the same R factor, but low thermal inertia, will transfer the heat in perhaps 2 hours. High thermal inertia is the reason many older public and commercial buildings, without modern air conditioning, still feel cool on the inside throughout the summer. The heat from the midday sun does not penetrate the buildings until late afternoon and evening, when it is unoccupied.

*R factor is the measure of the ability of insulation to decrease heat flow. The higher the factor, the better the thermal performance of the material.

Although these characteristics may not typify all historic buildings, the point is that historic buildings often have thermal properties that need little improvement. One must understand the inherent energy-saving qualities of a building, and assure, by re-opening the windows for instance, that the building functions as it was intended.

To reduce heating and cooling expenditures there are two broad courses of action that may be taken. First, begin *passive measures* to assure that a building and its existing components function as efficiently as possible without the necessity of making alterations or adding new materials. The second course of action is *preservation retrofitting*, which includes altering the building by making appropriate weatherization measures to improve thermal performance. Undertaking the passive measures and the preservation retrofitting recommended here could result in a 50% decrease in energy expenditures in historic buildings.

Passive Measures

The first passive measures to utilize are *operational controls*; that is, controlling *how* and *when* a building is used. These controls incorporate programmatic planning and scheduling efforts by the owner to minimize usage of energy-consuming equipment. A building owner should survey and quantify all aspects of energy usage, by evaluating the monies expended for electricity, gas, and fuel oil for a year, and by surveying how and when each room is used. This will identify ways of conserving energy by initiating operational controls such as:

- lowering the thermostat in the winter, raising it in the summer
- controlling the temperature in those rooms actually used
- reducing the level of illumination and number of lights (maximize natural light)
- using operable windows, shutters, awnings and vents as originally intended to control interior environment (maximize fresh air)
- having mechanical equipment serviced regularly to ensure maximum efficiency
- cleaning radiators and forced air registers to ensure proper operation

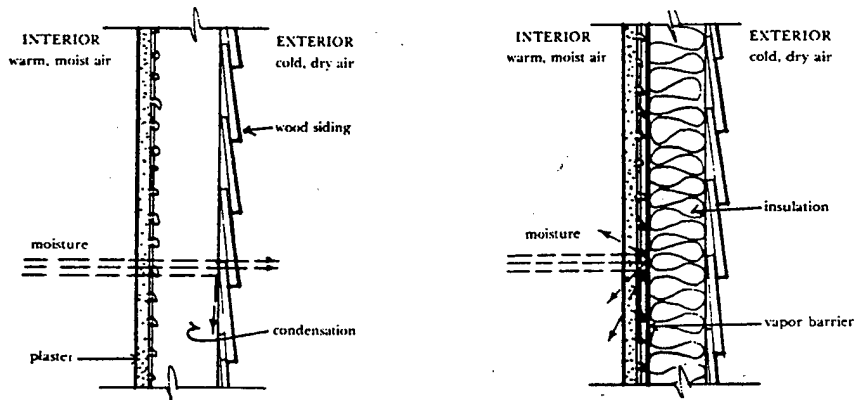

Figure 4. Heavy masonry walls in office buildings dramatically reduce the need for summer cooling because the thermal inertia (M factor) of the massive wall increases its thermal resistance (R factor), thus delaying the heat transfer into the building until late afternoon when the office workers have gone home. (Photo: Baird Smith)

Figure 5. Moisture migration through walls and roofing occurs as a matter of course in northern winter climates. Problems occur if there is no vapor barrier because the moisture may saturate the insulation and greatly reduce its thermal performance, as well as creating the potential for deterioration of the adjacent materials.

a. Typical wood frame wall where moist inside air freely migrates to the outside. Moisture may condense in the wall cavity and be absorbed into the adjacent materials and evaporate as the wall is heated by the sun.

b. Typical wall condition with insulation and a vapor barrier facing in (toward the heated side of the wall). The vapor barrier prevents moisture migration, thus keeping the insulation dry.



The passive measures outlined above can save as much as 30% of the energy used in a building. They should be the first undertakings to save energy in any existing building and are particularly appropriate for historic buildings because they do not necessitate building alterations or the introduction of new materials that may cause damage. Passive measures make energy sense, common sense, and preservation sense!

Preservation Retrofitting

In addition to passive measures, building owners may undertake certain retrofitting measures that will not jeopardize the historic character of the building and can be accomplished at a reasonable cost. Preservation retrofitting improves the thermal performance of the building, resulting in another 20%-30% reduction in energy.

When considering retrofitting measures, historic building owners should keep in mind that there are no permanent

solutions. One can only meet the standards being applied today with today's materials and techniques. In the future, it is likely that the standards and the technologies will change and a whole new retrofitting plan may be necessary. Thus, owners of historic buildings should limit retrofitting measures to those that achieve reasonable energy savings, at reasonable costs, with the least intrusion or impact on the character of the building. Overzealous retrofitting, which introduces the risk of damage to historic building materials, should not be undertaken.

The preservation retrofitting measures presented here, were developed to address the three most common problems in historic structures caused by some retrofitting actions. The first problem concerns retrofitting actions that necessitated inappropriate building alterations, such as the wholesale removal of historic windows, or the addition of insulating

The Secretary of the Interior's Standards for Historic Preservation Projects

The Standards for Historic Preservation were developed for the Historic Preservation Fund Grants-in-Aid Program and authorized by the National Historic Preservation Act of 1966. The standards are also used for determining whether a rehabilitation project qualifies as a "certified rehabilitation" pursuant to Section 2124 of the Tax Reform Act of 1976. There are eight "General Standards" (listed below), and additional specific standards and guidelines for the various categories of historic preservation projects.

General Standards

(Those shown in bold print are most applicable to preservation retrofitting.)

1. Every reasonable effort shall be made to provide a compatible use for a property that requires minimal alteration of the building structure, or site and its environment, or to use a property for its originally intended purpose.
2. The distinguishing original qualities or character of a building, structure, or site and its environment shall not be destroyed. The removal or alteration of any historic material or distinctive architectural features should be avoided when possible.
3. All buildings, structures, and sites shall be recognized as products of their own time. Alterations, which have no

historical basis and which seek to create an earlier appearance, shall be discouraged.

4. Changes, which may have taken place in the course of time, are evidence of the history and development of a building, structure, or site and its environment. These changes may have acquired significance in their own right, and this significance shall be recognized and respected.
5. Distinctive stylistic features or examples of skilled craftsmanship, which characterize a building, structure, or site, shall be treated with sensitivity.
6. Deteriorated architectural features shall be repaired rather than replaced, wherever possible. In the event replacement is necessary, the new material should match the material being replaced in composition, design, color, texture, and other visual qualities. Repair or replacement of missing architectural features should be based on accurate duplications of features, substantiated by historical, physical, or pictorial evidence rather than on conjectural designs or the availability of different architectural elements from other buildings or structures.
7. The surface cleaning of structures shall be undertaken with the gentlest means possible. Sandblasting and other cleaning methods that will damage the historic building materials shall not be undertaken.
8. Every reasonable effort shall be made to protect and preserve archeological resources affected by, or adjacent to any acquisition, protection, stabilization, preservation, rehabilitation, restoration, or reconstruction project.

aluminum siding, or installing dropped ceilings in significant interior spaces. To avoid such alterations, refer to the Secretary of the Interior's "Standards for Historic Preservation Projects" which provide the philosophical and practical basis for all preservation retrofitting measures.

The second problem area is to assure that retrofitting measures do not create moisture-related deterioration problems. One must recognize that large quantities of moisture are present on the interior of buildings.

In northern climates, the moisture may be a problem during the winter when it condenses on cold surfaces such as windows. As the moisture passes through the walls and roof it may condense within these materials, creating the potential for deterioration. The problem is avoided if a vapor barrier is added *facing in* (see figure 5).

In southern climates, insulation and vapor barriers are handled quite differently because moisture problems occur in the summer when the moist outside air is migrating to the interior of the building. In these cases, the insulation is installed with the vapor barrier *facing out* (opposite the treatment of northern climates). Expert advice should be sought to avoid moisture-related problems to insulation and building materials in southern climates.

The third problem area involves the avoidance of those materials that are chemically or physically incompatible with existing materials, or that are improperly installed. A serious problem exists with certain cellulose insulations that use ammonium or aluminum sulfate as a fire retardant, rather than boric acid which causes no problems. The sulfates react with moisture in the air forming sulfuric acid which can cause damage to most metals (including plumbing and wiring), building stones, brick and wood. In one instance, a metal building insulated with cellulose of this type collapsed when the sulfuric acid weakened the structural connections! To avoid problems such as these, refer to the recommendations provided here, and consult with local officials, such as a building inspector, the better business bureau, or a consumer protection agency.

Before a building owner or architect can plan retrofitting measures, some of the existing physical conditions of the building should be investigated. The basic building components (attic, roof, walls and basement) should be checked to determine the methods of construction used and the presence of insulation. Check the insulation for full coverage and whether there is a vapor barrier. This inspection will aid in determining the need for additional insulation, what type of insulation to use (batt, blown-in, or poured), and where to install it. In addition, sources of air infiltration should be checked at doors, windows, or where floor and ceiling systems meet the walls. Lastly, it is important to check the condition of the exterior wall materials, such as painted wooden siding or brick, and the condition of the roof, to determine the weather tightness of the building. A building owner must assure that rain and snow are kept out of the building before expending money for weatherization improvements.

Retrofitting Measures

The following listing includes the most common retrofitting measures; some measures are highly recommended for a preservation retrofitting plan, but, as will be explained, others are less beneficial or even harmful to the historic building:

- Air Infiltration
- Attic Insulation
- Storm Windows
- Basement and Crawl Space Insulation
- Duct and Pipe Insulation
- Awnings and Shading Devices
- Doors and Storm Doors
- Vestibules
- Replacement Windows
- Wall Insulation—Wood Frame

- Wall Insulation—Masonry Cavity Walls
- Wall Insulation—Installed on the Inside
- Wall Insulation—Installed on the Outside
- Waterproof Coatings for Masonry

The recommended measures to preservation retrofitting begin with those at the top of the list. The first ones are the simplest, least expensive, and offer the highest potential for saving energy. The remaining measures are not recommended for general use either because of potential technical and preservation problems, or because of the costs outweighing the anticipated energy savings. Specific solutions must be determined based on the facts and circumstances of the particular problem; therefore, advice from professionals experienced in historic preservation, such as, architects, engineers and mechanical contractors should be solicited.

Air Infiltration: Substantial heat loss occurs because cold outside air infiltrates the building through loose windows, doors, and cracks in the outside shell of the building. Adding weatherstripping to doors and windows, and caulking of open cracks and joints will substantially reduce this infiltration. Care should be taken not to reduce infiltration to the point where the building is completely sealed and moisture migration is prevented. Without some infiltration, condensation problems could occur throughout the building. Avoid caulking and weatherstripping materials that, when applied, introduce inappropriate colors or otherwise visually impair the architectural character of the building. Reducing air infiltration should be the first priority of a preservation retrofitting plan. The cost is low, little skill is required, and the benefits are substantial.

Attic Insulation: Heat rising through the attic and roof is a major source of heat loss, and reducing this heat loss should be one of the highest priorities in preservation retrofitting. Adding insulation in accessible attic spaces is very effective in saving energy and is generally accomplished at a reasonable cost, requiring little skill to install. The most common attic insulations include blankets of fiberglass and mineral wool, blown-in cellulose (treated with boric acid only), blowing wool, vermiculite, and blown fiberglass. If the attic is unheated (not used for habitation), then the insulation is placed between the floor joists with the vapor barrier facing down. If flooring is present, or if the attic is heated, the insulation is generally placed between the roof rafters with the vapor barrier facing in. All should be installed according to the manufacturer's recommendations. A weatherization manual entitled, "In the Bank . . . or Up the Chimney" (see the bibliography) provides detailed descriptions about a variety of installation methods used for attic insulation. The manual also recommends the amount of attic insulation used in various parts of the country. If the attic has some insulation, add more (but *without* a vapor barrier) to reach the total depth recommended.

Problems occur if the attic space is not properly ventilated. This lack of ventilation will cause the insulation to become saturated and lose its thermal effectiveness. The attic is adequately ventilated when the net area of ventilation (free area of a louver or vent) equals approximately 1/300 of the attic floor area. With adequate attic ventilation, the addition of attic insulation should be one of the highest priorities of a preservation retrofitting plan.

If the attic floor is inaccessible, or if it is impossible to add insulation along the roof rafters, consider attaching insulation to the ceilings of the rooms immediately below the attic. Some insulations are manufactured specifically for these cases and include a durable surface which becomes the new ceiling. This option should not be considered if it causes irreparable damage to historic or architectural spaces or features; however, in other cases, it could be a recommended measure of a preservation retrofitting plan.

Storm Windows: Windows are a primary source of heat loss because they are both a poor thermal barrier (R factor of only 0.89) and often a source of air infiltration. Adding storm windows greatly improves these poor characteristics. If a building has existing storm windows (either wood or metal framed), they should be retained. Assure they are tight fitting and in good working condition. If they are not in place, it is a recommended measure of a preservation retrofitting plan to add new metal framed windows on the exterior. This will result in a window assembly (historic window plus storm window) with an R factor of 1.79 which outperforms a double paned window assembly (with an air space up to 1/2") that only has an R factor of 1.72. When installing the storm windows, be careful not to damage the historic window frame. If the metal frames visually impair the appearance of the building, it may be necessary to paint them to match the color of the historic frame (see figure 6).

Triple-track metal storm windows are recommended because they are readily available, in numerous sizes, and at a reasonable cost. If a pre-assembled storm window is not available for a particular window size, and a custom-made storm window is required, the cost can be very high. In this case, compare the cost of manufacture and installation with the expected cost savings resulting from the increased thermal efficiency. Generally, custom-made storm windows, of either wood or metal frames, are not cost effective, and would not be recommended in a preservation retrofitting plan.

Interior storm window installations can be as thermally effective as exterior storm windows; however, there is high potential for damage to the historic window and sill from condensation. With storm windows on the interior, the outer sash (in this case the historic sash) will be cold in the winter, and hence moisture may condense there. This condensation often collects on the flat surface of the sash or window sill causing paint to blister and the wood to begin to deteriorate. Rigid plastic sheets are used as interior storm windows by attaching them directly to the historic sash. They are not quite as effective as the storm windows described previously because of the possibility of air infiltration around the historic sash. If the rigid plastic sheets are used, assure that they are installed with minimum damage to the historic sash, removed periodically to allow the historic sash to dry, and that the historic frame and sash are completely caulked and weather-stripped.

In most cases, interior storm windows of either metal frames or of plastic sheets are not recommended for preservation retrofitting because of the potential for damage to the historic window. If interior storm windows are in place, the potential for moisture deterioration can be lessened by opening (or removing, depending on the type) the storm windows during the mild months allowing the historic window to dry thoroughly.

Basement and Crawl Space Insulation: Substantial heat is lost through cold basements and crawl spaces. Adding insulation in these locations is an effective preservation retrofitting measure and should be a high priority action. It is complicated, however, because of the excessive moisture that is often present. One must be aware of this and assure that insulation is properly installed for the specific location. For instance, in crawl spaces and certain unheated basements, the insulation is generally placed between the first floor joists (the ceiling of the basement) with the vapor barrier facing up. Do not staple the insulation in place, because the staples often rust away. Use special anchors developed for insulation in moist areas such as these.

In heated basements, or where the basement contains the heating plant (furnace), or where there are exposed water and sewer pipes, insulation should be installed against foundation walls. Begin the insulation within the first floor joists, and proceed down the wall to a point at least 3 feet below the



Figure 6. The addition of triple track storm windows, as shown here, greatly improves the thermal performance of existing window assemblies, with a minimal impact on the appearance of the building. (Photo: Baird Smith)

exterior ground level if possible, with the vapor barrier facing in. Use either batt or rigid insulation.

Installing insulation in the basement or crawl space should be a high priority of a preservation retrofitting plan, as long as adequate provision is made to ventilate the unheated space, perhaps even by installing an exhaust fan.

Duct and Pipe Insulation: Wrapping insulation around heating and cooling ducts and hot water pipes, is a recommended preservation retrofitting measure. Use insulation which is intended for this use and install it according to manufacturer's recommendations. Note that air conditioning ducts will be cold in the summer, and hence moisture will condense there. Use insulation with the vapor barrier facing out, away from the duct. These measures are inexpensive and have little potential for damage to the historic building.

Awnings and Shading Devices: In the past, awnings and trees were used extensively to provide shade to keep buildings cooler in the summer. If awnings or trees are in place, keep them in good condition, and take advantage of their energy-saving contribution. Building owners may consider adding awnings or trees if the summer cooling load is substantial. If awnings are added, assure that they are installed without damaging the building or visually impairing its architectural character (see figure 7). If trees are added, select deciduous trees that provide shade in the summer but, after dropping their leaves, would allow the sun to warm the building in the winter. When planting trees, assure that they are no closer than 10 feet to the building to avoid damage to the foundations. Adding either awnings or shade trees may be expensive, but in hot climates, the benefits can justify the costs.

Doors and Storm Doors: Most historic wooden doors, if they are solid wood or paneled, have fairly good thermal properties and should not be replaced, especially if they are important architectural features. Assure that the frames and doors have proper maintenance, regular painting, and that caulking and weatherstripping is applied as necessary.

A storm door would improve the thermal performance of the historic door; however, recent studies indicate that installing a storm door is not normally cost effective in residential settings. The costs are high compared to the anticipated savings. Therefore, storm doors should only be added to

buildings in cold climates, and added in such a way to minimize the visual impact on the building's appearance. The storm door design should be compatible with the architectural character of the building and may be painted to match the colors of the historic door.

Vestibules: Vestibules create a secondary air space at a doorway to reduce air infiltration occurring while the primary door is open. If a vestibule is in place, retain it. If not, adding a vestibule, either on the exterior or interior, should be carefully considered to determine the possible visual impact on the character of the building. The energy savings would be comparatively small compared to construction costs. Adding a vestibule should be considered in very cold climates, or where door use is very high, but in either case, the additional question of visual intrusion must be resolved before it is added. For most cases with historic buildings, adding a vestibule is not recommended.

Replacement Windows: Unfortunately, a common weatherization measure, especially in larger buildings, has been the replacement of historic windows with modern double paned windows. The intention was to improve the thermal performance of the existing windows and to reduce long-term maintenance costs. The evidence is clear that adding exterior storm windows is a viable alternative to replacing the historic windows and it is the recommended approach in preservation retrofitting. However, if the historic windows are severely deteriorated and their repair would be impractical, or economically infeasible, then replacement windows may be warranted. The new windows, of either wood or metal, should closely match the historic windows in size, number of panes, muntin shape, frame, color and reflective qualities of the glass.

Wall Insulation—Wood Frame: The addition of wall insulation in a wood frame building is generally not recommended as a preservation retrofitting measure because the costs are high, and the potential for damage to historic building materials is even higher. Also, wall insulation is not particularly effective for small frame buildings (one story) because the heat loss from the uninsulated walls is a relatively small percentage of the total, and part of that can be attributed to infiltration. If, however, the historic building is two or more stories, and is located in a cold climate, wall insulation may be considered if extreme care (as explained later) is exercised with its installation.

The installation of wall insulation in historic frame buildings can result in serious technical and preservation problems. As discussed before, insulation must be kept dry to function properly, and requires a vapor barrier and some provision for air movement. Introducing insulation in wall cavities, without a vapor barrier and some ventilation can be disastrous. The insulation would become saturated, losing its thermal properties, and in fact, actually increasing the heat loss through the wall. Additionally, the moisture (in vapor form) may condense into water droplets and begin serious deterioration of adjacent building materials such as sills, window frames, framing and bracing. The situation is greatly complicated, because correcting such problems could necessitate the complete (and costly) dismantling of the exterior or interior wall surfaces. It should be clear that adding wall insulation has the potential for causing serious damage to historic building materials.

If adding wall insulation to frame buildings is determined to be absolutely necessary, the first approach should be to consider the careful removal of the exterior siding so that it may later be reinstalled. Then introduce batt insulation with the vapor barrier facing in into the now accessible wall cavity. The first step in this approach is an investigation to determine if the siding can be removed without causing serious damage.

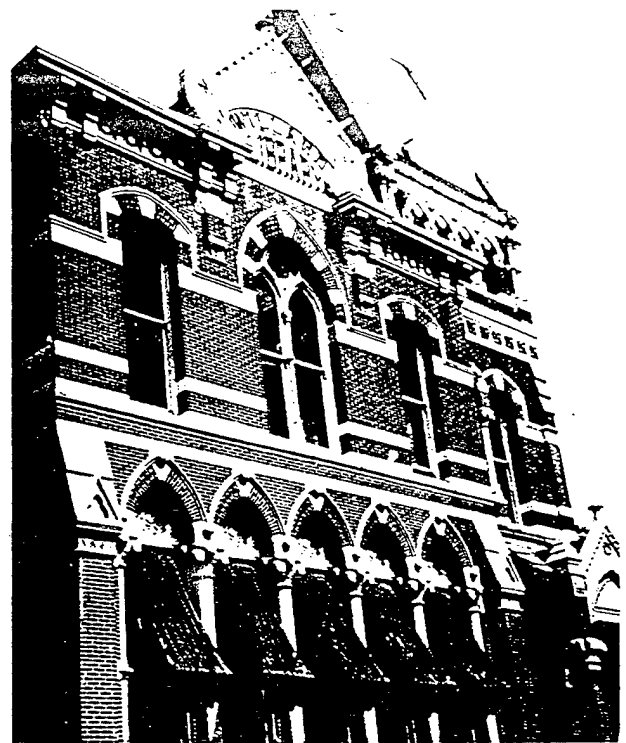

Figure 7. The awnings on the Willard Library in Evansville, Indiana, reduce heat gain in the summer and, when they are raised in the winter, radiant heat from the sun provides free supplementary heat. (Photo: Lee H. Nelson)

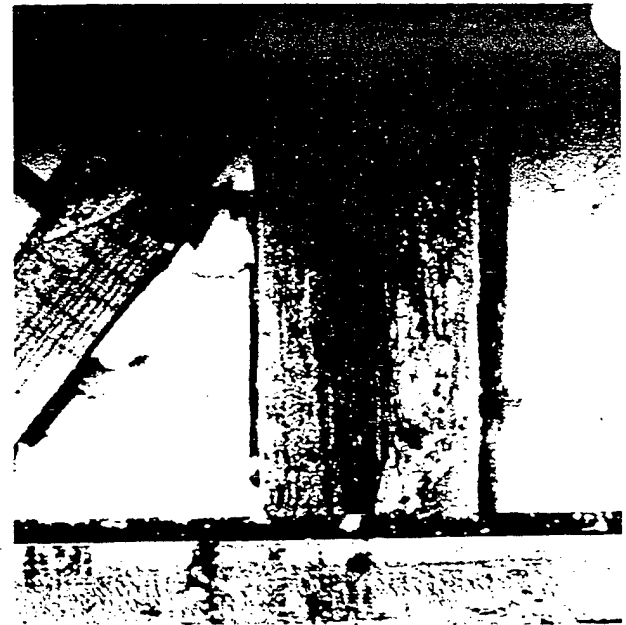

Figure 8. The white material seen between the wooden wall studs is urea-formaldehyde foam. It is injected into the wall cavity wet, and as it cures, large quantities of moisture are given off creating the potential for serious deterioration of adjacent materials and may cause paint to blister on interior and exterior wall surfaces. Additionally, foam can shrink as much as that shown here (about 7% by volume), thus reducing the predicted insulating performance. Until some of the technical problems are corrected, its use is not recommended in historic structures. (Photo: B. Smith)

If it is feasible, introducing insulation in this fashion provides the best possible solution to insulating a wall, and provides an excellent opportunity to view most of the structural system for possible hidden structural problems or insect infestations. A building owner should not consider this approach if it would result in substantial damage to or loss of historic wooden siding. Most siding, however, would probably withstand this method if reasonable care is exercised.

The second possible approach for wall insulation involves injecting or blowing insulation into the wall cavity. The common insulations are the loose fill types that can be blown into the cavity, the poured types, or the injected types such as foam. Obviously a vapor barrier cannot be simultaneously blown into the space. However, an equivalent vapor barrier can be created by assuring that the interior wall surfaces are covered with an impermeable paint layer. Two layers of oil base paint or one layer of impermeable latex paint constitute an acceptable vapor barrier. Naturally, for this to work, the paint layer must cover all interior surfaces adjacent to the newly installed wall insulation. Special attention should be given to rooms that are major sources of interior moisture—the laundry room, the bathrooms and the kitchen.

In addition to providing a vapor barrier, make provisions for some air to circulate in the wall cavity to help ventilate the insulation and the wall materials. This can be accomplished in several ways. One method is to install small screened vents (about 2 inches in diameter) at the base of each stud cavity. If this option is taken, the vents should be as inconspicuous as possible. A second venting method can be used where the exterior siding is horizontally lapped. Assure that each piece of siding is separated from the other, allowing some air to pass between them. Successive exterior paint layers often seal the joint between each piece of siding. Break the paint seal (carefully insert a chisel and twist) between the sections of exterior siding to provide the necessary ventilation for the insulation and wall materials.

With provisions for a vapor barrier (interior paint layer) and wall ventilation (exterior vents) satisfied, the appropriate type of wall insulation may then be selected. There are three recommended types to consider: blown cellulose (with boric acid as the fire retardant), vermiculite, or perlite. Cellulose is the preferred wall insulation because of its higher R factor and its capability to flow well into the various spaces within a wall cavity.

There are two insulation types that are not recommended for wall insulation: urea-formaldehyde foams, and cellulose which uses aluminum or ammonium sulfate instead of boric acid as a fire retardant. The cellulose treated with the sulfates reacts with moisture in the air and forms sulfuric acid which corrodes many metals and causes building stones to slowly disintegrate. This insulation is not appropriate for use in historic buildings.

Although urea-formaldehyde foams appear to have potential as retrofit materials (they flow into any wall cavity space and have a high R factor) their use is not recommended for preservation retrofitting until some serious problems are corrected. The major problem is that the injected material carries large quantities of moisture into the wall system. As the foam cures, this moisture must be absorbed into the adjacent materials. This process has caused interior and exterior paint to blister, and caused water to actually puddle at the base of a wall, creating the likelihood of serious deterioration to the historic building materials. There are other problems that affect both historic buildings and other existing buildings. Foams are a two-part chemical installed by franchised contractors. To obtain the exact proportion of the two parts, the foam must be mixed and installed under controlled conditions of temperature and humidity. There are cases where the controls were not followed and the foam either cured improperly, not attaining the desired R factor, or the

foam continued to emit a formaldehyde smell. In addition, the advertised maximum shrinkage after curing (3%) has been tested and found to be twice as high (see figure 8). Until this material is further developed and the risks eliminated, it is clearly not an appropriate material for preservation retrofitting.

Wall Insulation—Masonry Cavity Walls: Some owners of historic buildings with masonry cavity wall construction have attempted to introduce insulation into the cavity. This is not good practice because it ignores the fact that masonry cavity walls normally have acceptable thermal performance, needing no improvement. Additionally, introducing insulation into the cavity will most likely result in condensation problems and alter the intended function of the cavity. The air cavity acts as a vapor barrier in that moist air passing through the inner wythe of masonry meets the cold face of the outer wythe and condenses. Water droplets form and fall to the bottom of the wall cavity where they are channeled to the outside through weep holes. The air cavity also improves the thermal performance of the wall because it slows the transfer of heat or cold between the two wythes, causing the two wall masses to function independently with a thermal cushion between them.

Adding insulation to this cavity alters the vapor barrier and thermal cushion functions of the air space and will likely clog the weep holes, causing the moisture to puddle at the base of the wall. Also, the addition of insulation creates a situation where the moisture dew point (where moisture condenses) moves from the inner face of the outer wythe, into the outer wythe itself. Thus, during a freeze this condensation will freeze, causing spalling and severe deterioration. The evidence is clear that introducing insulation, of any type, into a masonry cavity wall is not recommended in a preservation retrofitting plan.

Wall Insulation—Installed on the Inside: Insulation could be added to a wall whether it be wooden or masonry, by attaching the insulation to furring strips mounted on the interior wall faces. Both rigid insulation, usually 1 or 2 inches thick, and batt insulation, generally 3½ inches thick, can be added in this fashion, with the vapor barrier facing in. Extra caution must be exercised if rigid plastic foam insulation is used because it can give off dense smoke and rapidly spreading flame when burned. Therefore, it must be installed with a fireproof covering, usually ½ inch gypsum wallboard. Insulation should not be installed on the inside if it necessitates relocation or destruction of important architectural decoration, such as cornices, chair rails, or window trims, or causes the destruction of historic plaster or other wall finishes. Insulation installed in this fashion would be expensive and could only be a recommended preservation retrofitting measure if it is a large building, located in a cold climate, and if the interior spaces and features have little or no architectural significance.

Wall Insulation—Installed on the Outside: There is a growing use of aluminum or vinyl siding installed directly over historic wooden sidings, supposedly to reduce long-term maintenance and to improve the thermal performance of the wall. From a preservation viewpoint, this is a poor practice for several reasons. New siding covers from view existing or potential deterioration problems or insect infestations. Additionally, installation often results in damage or alteration to existing decorative features such as beaded weatherboarding, window and door trim, corner boards, cornices, or roof trim. The cost of installing the artificial sidings, compared with the modest increase, if any, in the thermal performance of the wall does not add up to an effective energy-saving measure. The use of artificial siding is not recommended in a preservation retrofitting plan.

Good preservation practice would assure regular mainte-

nance of the existing siding through periodic painting and caulking. Where deterioration is present, individual pieces of siding should be removed and replaced with matching new ones. Refer to the earlier sections of this brief for recommended retrofitting measures to improve the thermal performance of wood frame walls.

Waterproof Coatings for Masonry: Some owners of historic buildings use waterproof coatings on masonry believing it would improve the thermal performance of the wall by keeping it dry (dry masonry would have a better R factor than when wet). Application of waterproof coatings is not recommended because the coatings actually trap moisture within the masonry, and can cause spalling and severe deterioration during a freezing cycle.

In cases where exterior brick is painted, consider continued periodic painting and maintenance, since paints are an excellent preservation treatment for brick. When repainting, a building owner might consider choosing a light paint color in warm climates, or a dark color in cold climates, to gain some advantage over the summer heat gain or winter heat loss, whichever the case may be. These colors should match those used historically on the building or should match colors available historically.

Mechanical Equipment

A detailed treatise of recommended or not recommended heating or air conditioning equipment, or of alternative energy sources such as solar energy or wind power, is beyond the scope of this brief. The best advice concerning mechanical equipment in historic buildings is to assure that the existing equipment works as efficiently as possible. If the best professional advice recommends replacement of existing equipment, a building owner should keep the following considerations in mind. First, as technology advances in the coming years, the equipment installed now will be outdated rapidly relative to the life of the historic building. Therefore, it may be best to wait and watch, until new technologies (such as solar energy) become more feasible, efficient, and inexpensive. Secondly, do not install new equipment and ductwork in such a way that its installation, or possible later removal, will cause irreversible damage to significant historic building materials. The concept of complete invisibility, which necessitates hiding piping and ductwork within wall and floor systems, may not always be appropriate for historic buildings because of the damage that often results. Every effort should be made to select a mechanical system that will require the least intrusion into the historic fabric of the building and that can be updated or altered without major intervention into the wall and floor systems. These points should be considered when weighing the decision to replace a less than efficient existing system with a costly new system, which may cause substantial damage to the historic building materials and in turn may prove inefficient in the future.

SUMMARY

The primary focus of this brief has been to describe ways to achieve the maximum energy savings in historic buildings without jeopardizing the architectural, cultural and historical qualities for which the properties have been recognized. This can be accomplished through undertaking the passive measures and the "recommended" preservation retrofitting. Secondly, this brief has emphasized the benefits of undertaking the retrofitting measures in phases so that the actual energy savings anticipated from each retrofitting measure can be realized. Thus, the "not recommended" retrofitting measures, with potential for damage or alteration of historic building materials, would not have to be undertaken, because the maximum feasible savings would have already been accomplished.

Lastly, and perhaps most important, we must recognize that

the technologies of retrofitting and weatherization are relatively new. Unfortunately, most current research and product development is directed toward *new construction*. It is hoped that reports such as this, and the realization that full 30% of all construction in the United States now involves work on existing buildings, will stimulate the development of new products that can be used with little hesitation in historic buildings. Until that time, owners of historic buildings can undertake the preservation retrofitting measures recommended here and greatly reduce the energy used for heating and cooling, without destroying those historic and architectural qualities that make the building worthy of preservation.

BIBLIOGRAPHY

- Recommended Weatherization Manuals and Instruction Booklets**
Nielsen, Sally E., ed. *Insulating the Old House*. Portland, Maine: Greater Portland Landmarks, Inc., 1977. Available from Greater Portland Landmarks, Inc., 165 State Street, Portland, Maine.
- Making the Most of Your Energy Dollars in Home Heating and Cooling*. Washington, D.C.: 1975. National Bureau of Standards, Consumer Information Series 8. Available from the Superintendent of Documents, U.S. Government Printing Office, Washington, D.C. 20402. Stock Number C13.53:8.
- In the Bank . . . or Up the Chimney*. Washington, D.C.: April 1975. Available from the Superintendent of Documents, U.S. Government Printing Office, Washington, D.C. 20402. Stock Number 023-000-00297-3.
- Other Suggested Readings**
American Society of Heating, Refrigerating and Air Conditioning Engineers, Inc. *ASHRAE Handbook of Fundamentals*. New York: ASHRAE, 1972.
- "Energy Conservation and Historic Preservation," supplement to *11593*, Vol. 2, No. 3. Washington, D.C.: Office of Archeology and Historic Preservation, U.S. Department of the Interior, June 1977. General Services Administration. *Energy Conservation Guideline for Existing Office Buildings*. Washington, D.C.: General Services Administration, February 1977.
- "The Overselling of Insulation." *Consumer Reports*, February 1978, pp. 67-73.
- Petersen, Stephen R. *Retrofitting Existing Housing for Energy Conservation: An Economic Analysis*, Building Science Series 64. Washington, D.C.: U.S. Government Printing Office, December 1974.
- Rossiter, Walter J., et al. *Urea-Formaldehyde Based Foam Insulations: An Assessment of Their Properties and Performance*. National Bureau of Standards, Technical Note 946. Washington, D.C.: July 1977.
- Smith, Baird M. "National Benefits of Rehabilitating Existing Buildings," supplement to *11593*, Vol 2, No. 5. Washington, D.C.: Office of Archeology and Historic Preservation, U.S. Department of the Interior, October 1977.
- Thermal Transmission Corrections for Dynamic Conditions—A Factor*. Brick Institute of America, Technical Notes on Brick Construction, 4 B, pp. 1-8. McLean, Virginia: March/April 1977.

The weathervane on the front cover is reproduced from *J. W. Fiske 1893* by permission of Wallace-Homestead Books, Des Moines, Iowa.

The line illustration for this brief was prepared by the author.

This publication was prepared pursuant to Executive Order 11593, "Protection and Enhancement of the Cultural Environment," which directs the Secretary of the Interior to "develop and make available to Federal agencies and State and local governments information concerning professional methods and techniques for preserving, improving, restoring and maintaining historic properties." The Brief has been developed under the technical editorship of Lee H. Nelson, AIA, Chief, Preservation Assistance Division, National Park Service, U.S. Department of the Interior, Washington, D.C. 20240. Comments on the usefulness of this information are welcome and can be sent to Mr. Nelson at the above address. This publication is not copyrighted and can be reproduced without penalty. Normal procedures for credit to the author and the National Park Service appreciated. April 1978.

4 PRESERVATION BRIEFS

Roofing for Historic Buildings

Sarah M. Sweetser

U.S. Department of the Interior National Park Service
Preservation Assistance Division Technical Preservation Services

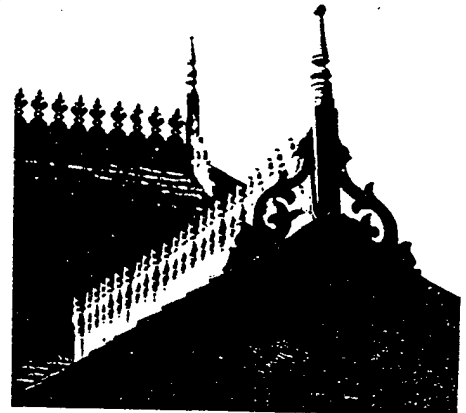

HABS

Significance of the Roof

A weather-tight roof is basic in the preservation of a structure, regardless of its age, size, or design. In the system that allows a building to work as a shelter, the roof sheds the rain, shades from the sun, and buffers the weather.

During some periods in the history of architecture, the roof imparts much of the architectural character. It defines the style and contributes to the building's aesthetics. The hipped roofs of Georgian architecture, the turrets of Queen Anne, the Mansard roofs, and the graceful slopes of the Shingle Style and Bungalow designs are examples of the use of roofing as a major design feature.

But no matter how decorative the patterning or how compelling the form, the roof is a highly vulnerable element of a shelter that will inevitably fail. A poor roof will permit the accelerated deterioration of historic building materials—masonry, wood, plaster, paint—and will cause general disintegration of the basic structure. Furthermore, there is an urgency involved in repairing a leaky roof since such repair costs will quickly become prohibitive. Although such action is desirable as soon as a failure is discovered, temporary patching methods should be carefully chosen to prevent inadvertent damage to sound or historic roofing materials and related features. Before any repair work is performed, the historic value of the materials used on the roof should be understood. Then a complete internal and external inspection of the roof should be planned to determine all the causes of failure and to identify the alternatives for repair or replacement of the roofing.

Historic Roofing Materials in America

Clay Tile: European settlers used clay tile for roofing as early as the mid-17th century; many pantiles (S-curved tiles), as well as flat roofing tiles, were used in Jamestown, Virginia. In some cities such as New York and Boston, clay was popularly used as a precaution against such fire as those that engulfed London in 1666 and scorched Boston in 1679.

Tiles roofs found in the mid-18th century Moravian settlements in Pennsylvania closely resembled those found in Germany. Typically, the tiles were 14-15" long, 6-7" wide with a curved butt. A lug on the back allowed the tiles to hang on the lathing without nails or pegs. The tile surface was usually scored with finger marks to promote drainage. In the Southwest, the tile roofs of the Spanish missionaries (mission tiles) were first manufactured (ca. 1780) at the Mission San Antonio de Padua in California. These semicircular tiles were

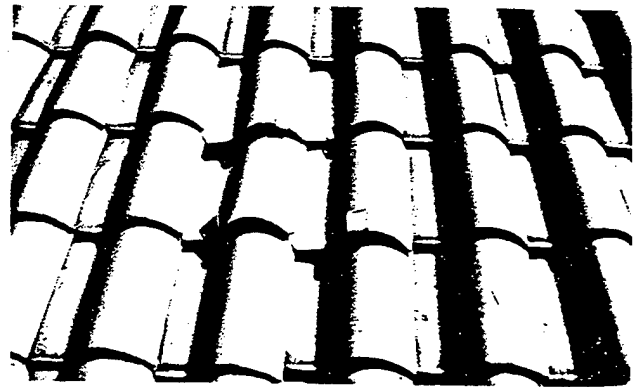

Repairs on this pantile roof were made with new tiles held in place with metal hangers. (Main Building, Ellis Island, New York)

made by molding clay over sections of logs, and they were generally 22" long and tapered in width.

The plain or flat rectangular tiles most commonly used from the 17th through the beginning of the 19th century measured about 10" by 6" by 1/2", and had two holes at one end for a nail or peg fastener. Sometimes mortar was applied between the courses to secure the tiles in a heavy wind.

In the mid-19th century, tile roofs were often replaced by sheet-metal roofs, which were lighter and easier to install and maintain. However, by the turn of the century, the Romanesque Revival and Mission style buildings created a new demand and popularity for this picturesque roofing material.

Slate: Another practice settlers brought to the New World was slate roofing. Evidence of roofing slates have been found also among the ruins of mid-17th-century Jamestown. But because of the cost and the time required to obtain the material, which was mostly imported from Wales, the use of slate was initially limited. Even in Philadelphia (the second largest city in the English-speaking world at the time of the Revolution) slates were so rare that "The Slate Roof House" distinctly referred to William Penn's home built late in the 1600s. Sources of native slate were known to exist along the eastern seaboard from Maine to Virginia, but difficulties in inland transportation limited its availability to the cities, and contributed to its expense. Welsh slate continued to be imported until the development of canals and railroads in the mid-19th century made American slate more accessible and economical.

Slate was popular for its durability, fireproof qualities, and



The Victorians loved to use different colored slates to create decorative patterns on their roofs, an effect which cannot be easily duplicated by substitute materials. Before any repair work on a roof such as this, the slate sizes, colors, and position of the patterning should be carefully recorded to assure proper replacement. (Ebenezer Maxwell Mansion, Philadelphia, Pennsylvania, photo courtesy of William D. Hershey)

aesthetic potential. Because slate was available in different colors (red, green, purple, and blue-gray), it was an effective material for decorative patterns on many 19th-century roofs (Gothic and Mansard styles). Slate continued to be used well into the 20th century, notably on many Tudor revival style buildings of the 1920s.

Shingles: Wood shingles were popular throughout the country in all periods of building history. The size and shape of the shingles as well as the detailing of the shingle roof differed according to regional craft practices. People within particular regions developed preferences for the local species of wood that most suited their purposes. In New England and the Delaware Valley, white pine was frequently used; in the South, cypress and oak; in the far west, red cedar or redwood. Sometimes a protective coating was applied to increase the durability of the shingle such as a mixture of brick dust and fish oil, or a paint made of red iron oxide and linseed oil.

Commonly in urban areas, wooden roofs were replaced with more fire resistant materials, but in rural areas this was not a major concern. On many Victorian country houses, the practice of wood shingling survived the technological advances of metal roofing in the 19th century, and near the turn of the century enjoyed a full revival in its namesake, the Shingle Style. Colonial revival and the Bungalow styles in the 20th century assured wood shingles a place as one of the most fashionable, domestic roofing materials.

Metal: Metal roofing in America is principally a 19th-century phenomenon. Before then the only metals commonly



Replacement of particular historic details is important to the individual historic character of a roof, such as the treatment at the eaves of this rounded butt wood shingle roof. Also note that the surface of the roof was carefully sloped to drain water away from the side of the dormer. In the restoration, this function was augmented with the addition of carefully concealed modern metal flashing. (Mount Vernon, Virginia)

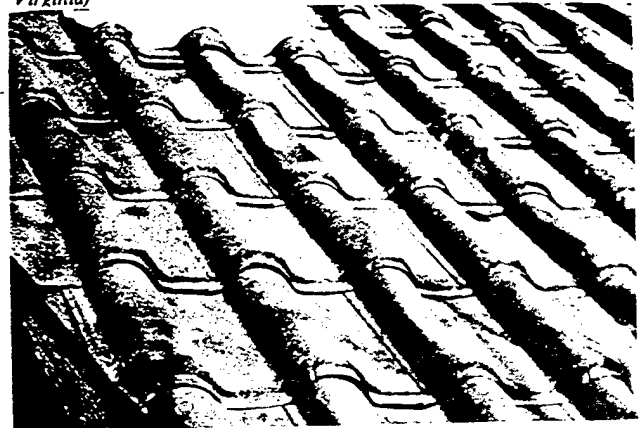

Galvanized sheet-metal shingles imitating the appearance of pantiles remained popular from the second half of the 19th century into the 20th century. (Episcopal Church, now the Jerome Historical Society Building, Jerome, Arizona, 1927)

used were lead and copper. For example, a lead roof covered "Rosewell," one of the grandest mansions in 18th-century Virginia. But more often, lead was used for protective flashing. Lead, as well as copper, covered roof surfaces where wood, tile, or slate shingles were inappropriate because of the roof's pitch or shape.

Copper with standing seams covered some of the more notable early American roofs including that of Christ Church (1727-1744) in Philadelphia. Flat-seamed copper was used on many domes and cupolas. The copper sheets were imported from England until the end of the 18th century when facilities for rolling sheet metal were developed in America.

Sheet iron was first known to have been manufactured here by the Revolutionary War financier, Robert Morris, who had a rolling mill near Trenton, New Jersey. At his mill Morris produced the roof of his own Philadelphia mansion, which he started in 1794. The architect Benjamin H. Latrobe used sheet iron to replace the roof on Princeton's "Nassau Hall," which had been gutted by fire in 1802.

The method for corrugating iron was originally patented in England in 1829. Corrugating stiffened the sheets, and allowed greater span over a lighter framework, as well as reduced installation time and labor. In 1834 the American architect William Strickland proposed corrugated iron to cover his design for the market place in Philadelphia.

Galvanizing with zinc to protect the base metal from rust was developed in France in 1837. By the 1850s the material was used on post offices and customhouses, as well as on train sheds and factories. In 1857 one of the first metal roofs in the



Repeated repair with asphalt, which cracks as it hardens, has created a blistered surface on this sheet-metal roof and built-in gutter, which will retain water. Repairs could be made by carefully heating and scraping the surface clean, repairing the holes in the metal with a flexible mastic compound or a metal patch, and coating the surface with a fibre paint. (Roane County Courthouse, Kingston, Tennessee, photo courtesy of Building Conservation Technology, Inc.)

South was installed on the U.S. Mint in New Orleans. The Mint was thereby "fireproofed" with a 20-gauge galvanized, corrugated iron roof on iron trusses.

Tin-plate iron, commonly called "tin roofing," was used extensively in Canada in the 18th century, but it was not as common in the United States until later. Thomas Jefferson was an early advocate of tin roofing, and he installed a standing-seam tin roof on "Monticello" (ca. 1770-1802). The Arch Street Meetinghouse (1804) in Philadelphia had tin shingles laid in a herringbone pattern on a "piazza" roof.

However, once rolling mills were established in this country, the low cost, light weight, and low maintenance of tin plate made it the most common roofing material. Embossed tin shingles, whose surfaces created interesting patterns, were popular throughout the country in the late 19th century. Tin roofs were kept well-painted, usually red; or, as the architect A. J. Davis suggested, in a color to imitate the green patina of copper.

Terne plate differed from tin plate in that the iron was dipped in an alloy of lead and tin, giving it a duller finish. Historic, as well as modern, documentation often confuses the two, so much that it is difficult to determine how often actual "terne" was used.

Zinc came into use in the 1820s, at the same time tin plate was becoming popular. Although a less expensive substitute for lead, its advantages were controversial, and it was never widely used in this country.

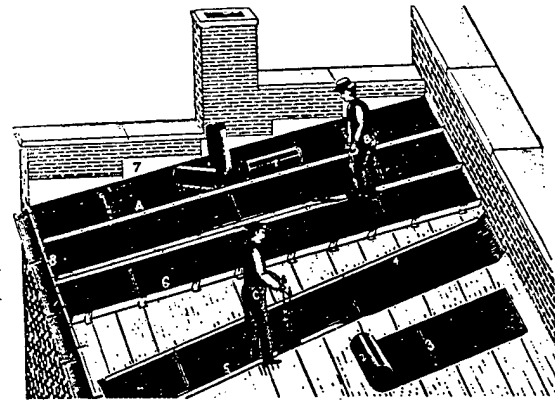

A Chicago firm's catalog dated 1896 illustrates a method of unrolling, turning the edges, and finishing the standing seam on a metal roof.



Tin shingles, commonly embossed to imitate wood or tile, or with a decorative design, were popular as an inexpensive, textured roofing material. These shingles 8¹/₈ inch by 12¹/₂ inch on the exposed surface were designed with interlocking edges, but they have been repaired by surface nailing, which may cause future leakage. (Ballard House, Yorktown, Virginia, photo by Gordie Whittington, National Park Service)

Other Materials: Asphalt shingles and roll roofing were used in the 1890s. Many roofs of asbestos, aluminum, stainless steel, galvanized steel, and lead-coated copper may soon have historic values as well. Awareness of these and other traditions of roofing materials and their detailing will contribute to more sensitive preservation treatments.

Locating the Problem

Failures of Surface Materials

When trouble occurs, it is important to contact a professional, either an architect, a reputable roofing contractor, or a craftsman familiar with the inherent characteristics of the particular historic roofing system involved. These professionals may be able to advise on immediate patching procedures and help plan more permanent repairs. A thorough examination of the roof should start with an appraisal of the existing condition and quality of the roofing material itself. Particular attention should be given to any southern slope because year-round exposure to direct sun may cause it to break down first.

Wood: Some historic roofing materials have limited life expectancies because of normal organic decay and "wear." For example, the flat surfaces of wood shingles erode from exposure to rain and ultraviolet rays. Some species are more hardy than others, and heartwood, for example, is stronger and more durable than sapwood.

Ideally, shingles are split with the grain perpendicular to

the surface. This is because if shingles are sawn across the grain, moisture may enter the grain and cause the wood to deteriorate. Prolonged moisture on or in the wood allows moss or fungi to grow, which will further hold the moisture and cause rot.

Metal: Of the inorganic roofing materials used on historic buildings, the most common are perhaps the sheet metals: lead, copper, zinc, tin plate, terne plate, and galvanized iron. In varying degrees each of these sheet metals are likely to deteriorate from chemical action by pitting or streaking. This can be caused by airborne pollutants; acid rainwater; acids from lichen or moss; alkalis found in lime mortars or portland cement, which might be on adjoining features and washes down on the roof surface; or tannic acids from adjacent wood sheathings or shingles made of red cedar or oak.

Corrosion from "galvanic action" occurs when dissimilar metals, such as copper and iron, are used in direct contact. Corrosion may also occur even though the metals are physically separated; one of the metals will react chemically against the other in the presence of an electrolyte such as rainwater. In roofing, this situation might occur when either a copper roof is decorated with iron cresting, or when steel nails are used in copper sheets. In some instances the corrosion can be prevented by inserting a plastic insulator between the dissimilar materials. Ideally, the fasteners should be a metal sympathetic to those involved.

Iron rusts unless it is well-painted or plated. Historically this problem was avoided by use of tin plating or galvanizing. But this method is durable only as long as the coating remains intact. Once the plating is worn or damaged, the exposed iron will rust. Therefore, any iron-based roofing material needs to be undercoated, and its surface needs to be kept well-painted to prevent corrosion.

One cause of sheet metal deterioration is fatigue. Depending upon the size and the gauge of the metal sheets, wear and metal failure can occur at the joints or at any protrusions in the sheathing as a result from the metal's alternating movement to thermal changes. Lead will tear because of "creep," or the gravitational stress that causes the material to move down the roof slope.

Slate: Perhaps the most durable roofing materials are slate and tile. Seemingly indestructible, both vary in quality. Some slates are hard and tough without being brittle. Soft slates are more subject to erosion and to attack by airborne and rain-

water chemicals, which cause the slates to wear at nail holes, to delaminate, or to break. In winter, slate is very susceptible to breakage by ice, or ice dams.

Tile: Tiles will weather well, but tend to crack or break if hit, as by tree branches, or if they are walked on improperly. Like slates, tiles cannot support much weight. Low quality tiles that have been insufficiently fired during manufacture, will craze and spall under the effects of freeze and thaw cycles on their porous surfaces.

Failures of Support Systems

Once the condition of the roofing material has been determined, the related features and support systems should be examined on the exterior and on the interior of the roof. The gutters and downspouts need periodic cleaning and maintenance since a variety of debris fill them, causing water to back up and seep under roofing units. Water will eventually cause fasteners, sheathing, and roofing structure to deteriorate. During winter, the daily freeze-thaw cycles can cause ice floes to develop under the roof surface. The pressure from these ice floes will dislodge the roofing material, especially slates, shingles, or tiles. Moreover, the buildup of ice dams above the gutters can trap enough moisture to rot the sheathing or the structural members.

Many large public buildings have built-in gutters set within the perimeter of the roof. The downspouts for these gutters may run within the walls of the building, or drainage may be through the roof surface or through a parapet to exterior downspouts. These systems can be effective if properly maintained; however, if the roof slope is inadequate for good runoff, or if the traps are allowed to clog, rainwater will form pools on the roof surface. Interior downspouts can collect debris and thus back up, perhaps leaking water into the surrounding walls. Exterior downspouts may fill with water, which in cold weather may freeze and crack the pipes. Conduits from the built-in gutter to the exterior downspout may also leak water into the surrounding roof structure or walls.

Failure of the flashing system is usually a major cause of roof deterioration. Flashing should be carefully inspected for failure caused by either poor workmanship, thermal stress, or metal deterioration (both of flashing material itself and of the fasteners). With many roofing materials, the replacement of flashing on an existing roof is a major operation, which may require taking up large sections of the roof surface. Therefore, the installation of top quality flashing material on



This detail shows slate delamination caused by a combination of weathering and pollution. In addition, the slates have eroded around the repair nails, incorrectly placed in the exposed surface of the slates. (Lower Pontalba Building, New Orleans, photo courtesy of Building Conservation Technology, Inc.)

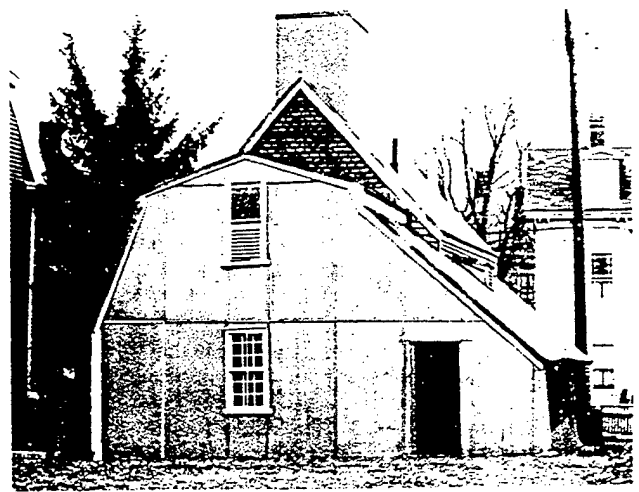

Temporary stabilization or "mothballing" with materials such as plywood and building paper can protect the roof of a project until it can be properly repaired or replaced. (Narbonne House, Salem, Massachusetts)



These two views of the same house demonstrate how the use of a substitute material can drastically affect the overall character of a structure. The textural interest of the original tile roof was lost with the use of asphalt shingles. Recent preservation efforts are replacing the tile roof. (Frank House, Kearney, Nebraska, photo courtesy of the Nebraska State Historical Society, Lincoln, Nebraska)

a new or replaced roof should be a primary consideration. Remember, some roofing and flashing materials are not compatible.

Roof fasteners and clips should also be made of a material compatible with all other materials used, or coated to prevent rust. For example, the tannic acid in oak will corrode iron nails. Some roofs such as slate and sheet metals may fail if nailed too rigidly.

If the roof structure appears sound and nothing indicates recent movement, the area to be examined most closely is the roof substrate—the sheathing or the battens. The danger spots would be near the roof plates, under any exterior patches, at the intersections of the roof planes, or at vertical surfaces such as dormers. Water penetration, indicating a breach in the roofing surface or flashing, should be readily apparent, usually as a damp spot or stain. Probing with a small pen knife may reveal any rot which may indicate previously undetected damage to the roofing membrane. Insect infestation evident by small exit holes and frass (a sawdust-like debris) should also be noted. Condensation on the underside of the roofing is undesirable and indicates improper ventilation. Moisture will have an adverse effect on any roofing material; a good roof stays dry inside and out.

Repair or Replace

Understanding potential weaknesses of roofing material also requires knowledge of repair difficulties. Individual slates can be replaced normally without major disruption to the rest of the roof, but replacing flashing on a slate roof can require substantial removal of surrounding slates. If it is the substrate or a support material that has deteriorated, many surface materials such as slate or tile can be reused if handled carefully during the repair. Such problems should be evaluated at the outset of any project to determine if the roof can be effectively patched, or if it should be completely replaced.

Will the repairs be effective? Maintenance costs tend to multiply once trouble starts. As the cost of labor escalates, repeated repairs could soon equal the cost of a new roof.

The more durable the surface is initially, the easier it will be to maintain. Some roofing materials such as slate are expensive to install, but if top quality slate and flashing are used, it will last 40-60 years with minimal maintenance. Although the installation cost of the roof will be high, low maintenance needs will make the lifetime cost of the roof less expensive.

Historical Research

In a restoration project, research of documents and physical investigation of the building usually will establish the roof's history. Documentary research should include any original plans or building specifications, early insurance surveys, newspaper descriptions, or the personal papers and files of people who owned or were involved in the history of the building. Old photographs of the building might provide evidence of missing details.

Along with a thorough understanding of any written history of the building, a physical investigation of the roofing and its structure may reveal information about the roof's construction history. Starting with an overall impression of the structure, are there any changes in the roof slope, its configuration, or roofing materials? Perhaps there are obvious patches or changes in patterning of exterior brickwork where a gable roof was changed to a gambrel, or where a whole upper story was added. Perhaps there are obvious stylistic changes in the roof line, dormers, or ornamentation. These observations could help one understand any important alteration, and could help establish the direction of further investigation.

Because most roofs are physically out of the range of careful scrutiny, the "principle of least effort" has probably limited the extent and quality of previous patching or replacing, and usually considerable evidence of an earlier roof surface remains. Sometimes the older roof will be found as an underlayment of the current exposed roof. Original roofing may still be intact in awkward places under later features on a roof. Often if there is any unfinished attic space, remnants of roofing may have been dropped and left when the roof was being built or repaired. If the configuration of the roof has been changed, some of the original material might still be in place under the existing roof. Sometimes whole sections of the roof and roof framing will have been left intact under the higher roof. The profile and/or flashing of the earlier roof may be apparent on the interior of the walls at the level of the alteration. If the sheathing or lathing appears to have survived changes in the roofing surface, they may contain evidence of the roofing systems. These may appear either as dirt marks, which provide "shadows" of a roofing material, or as nails broken or driven down into the wood, rather than pulled out during previous alterations or repairs. Wooden headers in the roof framing may indicate that earlier chimneys or skylights have been removed. Any metal ornamentation that might have existed may be indicated by anchors or unusual markings along the ridge or at other edges of the roof. This primary

evidence is essential for a full understanding of the roof's history.

Caution should be taken in dating early "fabric" on the evidence of a single item, as recycling of materials is not a mid-20th-century innovation. Carpenters have been reusing materials, sheathing, and framing members in the interest of economy for centuries. Therefore, any analysis of the materials found, such as nails or sawmarks on the wood, requires an accurate knowledge of the history of local building practices before any final conclusion can be accurately reached. It is helpful to establish a sequence of construction history for the roof and roofing materials; any historic fabric or pertinent evidence in the roof should be photographed, measured, and recorded for future reference.

During the repair work, useful evidence might unexpectedly appear. It is essential that records be kept of any type of work on a historic building, before, during, and after the project. Photographs are generally the easiest and fastest method, and should include overall views and details at the gutters, flashing, dormers, chimneys, valleys, ridges, and eaves. All photographs should be immediately labeled to insure accurate identification at a later date. Any patterning or design on the roofing deserves particular attention. For example, slate roofs are often decorative and have subtle changes in size, color, and texture, such as a gradually decreasing coursing length from the eave to the peak. If not carefully noted before a project begins, there may be problems in replacing the surface. The standard reference for this phase of the work is *Recording Historic Buildings*, compiled by Harley J. McKee for the Historic American Buildings Survey, National Park Service, Washington, D.C., 1970.

Replacing the Historic Roofing Material

Professional advice will be needed to assess the various aspects of replacing a historic roof. With some exceptions, most historic roofing materials are available today. If not, an architect or preservation group who has previously worked with the same type material may be able to recommend suppliers. Special roofing materials, such as tile or embossed metal shingles, can be produced by manufacturers of related products that are commonly used elsewhere, either on the exterior or interior of a structure. With some creative thinking and research, the historic materials usually can be found.

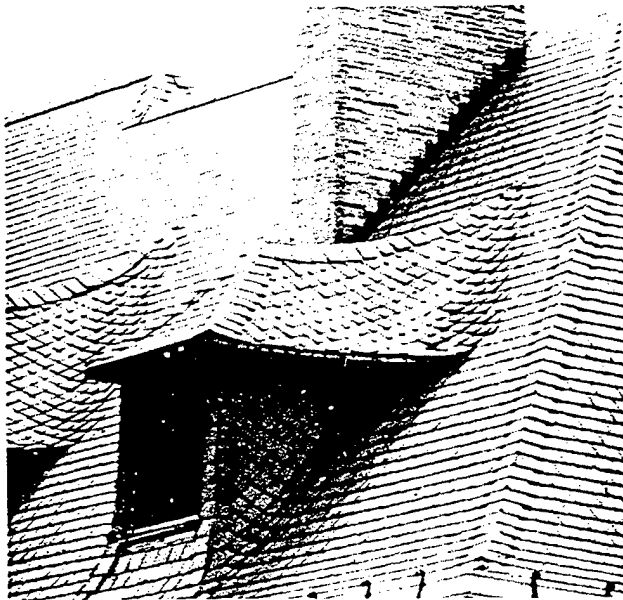

Because of the roof's visibility, the slate detailing around the dormers is important to the character of this structure. Note how the slates swirl from a horizontal pattern on the main roof to a diamond pattern on the dormer roofs and side walls. (18th and Que Streets, NW, Washington, D.C.)

Craft Practices: Determining the craft practices used in the installation of a historic roof is another major concern in roof restoration. Early builders took great pride in their work, and experience has shown that the "rustic" or irregular designs commercially labeled "Early American" are a 20th-century invention. For example, historically, wood shingles underwent several distinct operations in their manufacture including splitting by hand, and smoothing the surface with a draw knife. In modern nomenclature, the same item would be a "tapersplit" shingle which has been dressed. Unfortunately, the rustic appearance of today's commercially available "handsplit" and re-sawn shingle bears no resemblance to the hand-made roofing materials used on early American buildings.

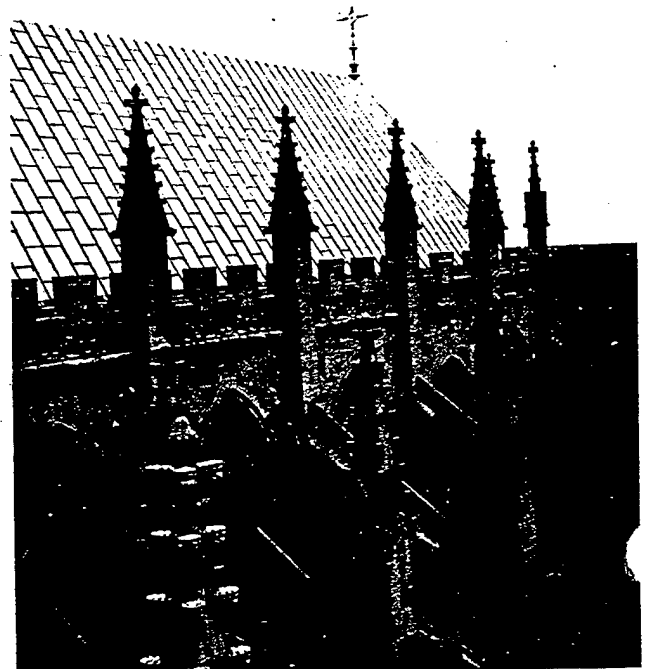

Good design and quality materials for the roof surface, fastenings, and flashing minimize roofing failures. This is essential on roofs such as on the National Cathedral where a thorough maintenance inspection and minor repairs cannot be done easily without special scaffolding. However, the success of the roof on any structure depends on frequent cleaning and repair of the gutter system. (Washington, D.C., photo courtesy of John Burns, A.I.A.)

Early craftsmen worked with a great deal of common sense; they understood their materials. For example they knew that wood shingles should be relatively narrow; shingles much wider than about 6" would split when walked on, or they may curl or crack from varying temperature and moisture. It is important to understand these aspects of craftsmanship, remembering that people wanted their roofs to be weather-tight and to last a long time. The recent use of "mother-goose" shingles on historic structures is a gross underestimation of the early craftsman's skills.

Supervision: Finding a modern craftsman to reproduce historic details may take some effort. It may even involve some special instruction to raise his understanding of certain historic craft practices. At the same time, it may be pointless (and expensive) to follow historic craft practices in any construction that will not be visible on the finished product. But if the roofing details are readily visible, their appearance should be based on architectural evidence or on historic prototypes. For instance, the spacing of the seams on a standing-seam metal roof will affect the building's overall scale and should therefore match the original dimensions of the seams.

Many older roofing practices are no longer performed because of modern improvements. Research and review of specific detailing in the roof with the contractor before beginning the project is highly recommended. For example, one early craft practice was to finish the ridge of a wood shingle roof with a roof "comb"—that is, the top course of one slope of the roof was extended uniformly beyond the peak to shield the ridge, and to provide some weather protection for the raw horizontal edges of the shingles on the other slope. If the "comb" is known to have been the correct detail, it should be used. Though this method leaves the top course vulnerable to the weather, a disguised strip of flashing will strengthen this weak point.

Detail drawings or a sample mock-up will help ensure that the contractor or craftsman understands the scope and special requirements of the project. It should never be assumed that the modern carpenter, slater, sheet metal worker, or roofer will know all the historic details. Supervision is as important as any other stage of the process.



Special problems inherent in the design of an elaborate historic roof can be controlled through the use of good materials and regular maintenance. The shape and detailing are essential elements of the building's historic character, and should not be modified, despite the use of alternative surface materials. (Gamwell House, Bellingham, Washington)

Alternative Materials

The use of the historic roofing material on a structure may be restricted by building codes or by the availability of the materials, in which case an appropriate alternative will have to be found.

Some municipal building codes allow variances for roofing materials in historic districts. In other instances, individual variances may be obtained. Most modern heating and cooking is fueled by gas, electricity, or oil—none of which emit the hot embers that historically have been the cause of roof fires. Where wood burning fireplaces or stoves are used, spark arrestor screens at the top of the chimneys help to prevent flaming material from escaping, thus reducing the number of fires that start at the roof. In most states, insurance rates have been equalized to reflect revised considerations for the risks involved with various roofing materials.

In a rehabilitation project, there may be valid reasons for replacing the roof with a material other than the original. The historic roofing may no longer be available, or the cost of obtaining specially fabricated materials may be prohibitive. But

the decision to use an alternative material should be weighed carefully against the primary concern to keep the historic character of the building. If the roof is flat and is not visible from any elevation of the building, and if there are advantages to substituting a modern built-up composition roof for what might have been a flat metal roof, then it may make better economic and construction sense to use a modern roofing method. But if the roof is readily visible, the alternative material should match as closely as possible the scale, texture, and coloration of the historic roofing material.

Asphalt shingles or ceramic tiles are common substitute materials intended to duplicate the appearance of wood shingles, slates, or tiles. Fire-retardant, treated wood shingles are currently available. The treated wood tends, however, to be brittle, and may require extra care (and expense) to install. In some instances, shingles laid with an interlay of fire-retardant building paper may be an acceptable alternative.

Lead-coated copper, terne-coated steel, and aluminum/zinc-coated steel can successfully replace tin, terne plate, zinc, or lead. Copper-coated steel is a less expensive (and less durable) substitute for sheet copper.

The search for alternative roofing materials is not new. As early as the 18th century, fear of fire cause many wood shingle or board roofs to be replaced by sheet metal or clay tile. Some historic roofs were failures from the start, based on over-ambitious and naive use of materials as they were first developed. Research on a structure may reveal that an inadequately designed or a highly combustible roof was replaced early in its history, and therefore restoration of a later roof material would have a valid precedent. In some cities, the substitution of sheet metal on early row houses occurred as soon as the rolled material became available.

Cost and ease of maintenance may dictate the substitution of a material wholly different in appearance from the original. The practical problems (wind, weather, and roof pitch) should be weighed against the historical consideration of scale, texture, and color. Sometimes the effect of the alternative material will be minimal. But on roofs with a high degree of visibility and patterning or texture, the substitution may seriously alter the architectural character of the building.

Temporary Stabilization

It may be necessary to carry out an immediate and temporary stabilization to prevent further deterioration until research can determine how the roof should be restored or rehabilitated, or until funding can be provided to do a proper job. A simple covering of exterior plywood or roll roofing might provide adequate protection, but any temporary covering should be applied with caution. One should be careful not to overload the roof structure, or to damage or destroy historic evidence or fabric that might be incorporated into a new roof at a later date. In this sense, repairs with caulking or bituminous patching compounds should be recognized as potentially harmful, since they are difficult to remove, and at their best, are very temporary.

Precautions

The architect or contractor should warn the owner of any precautions to be taken against the specific hazards in installing the roofing material. Soldering of sheet metals, for instance, can be a fire hazard, either from the open flame or from overheating and undected smoldering of the wooden substrate materials.

Thought should be given to the design and placement of any modern roof appurtenances such as plumbing stacks, air vents, or TV antennas. Consideration should begin with the placement of modern plumbing on the interior of the building, otherwise a series of vent stacks may pierce the roof membrane at various spots creating maintenance problems as well as aesthetic ones. Air handling units placed in the attic space will require vents which, in turn, require sensitive design. Incorporating these in unused chimneys has been very successful

in the past.

Whenever gutters and downspouts are needed that were not on the building historically, the additions should be made as unobtrusively as possible, perhaps by painting them out with a color compatible with the nearby wall or trim.

Maintenance

Although a new roof can be an object of beauty, it will not be protective for long without proper maintenance. At least twice a year, the roof should be inspected against a checklist. All changes should be recorded and reported. Guidelines should be established for any foot traffic that may be required for the maintenance of the roof. Many roofing materials should not be walked on at all. For some—slate, asbestos, and clay tile—a self-supporting ladder might be hung over the ridge of the roof, or planks might be spanned across the roof surface. Such items should be specifically designed and kept in a storage space accessible to the roof. If exterior work ever requires hanging scaffolding, use caution to insure that the anchors do not penetrate, break, or wear the roofing surface, gutters, or flashing.

Any roofing system should be recognized as a membrane that is designed to be self-sustaining, but that can be easily damaged by intrusions such as pedestrian traffic or fallen tree branches. Certain items should be checked at specific times. For example, gutters tend to accumulate leaves and debris during the spring and fall and after heavy rain. Hidden gutter screening both at downspouts and over the full length of the gutter could help keep them clean. The surface material would require checking after a storm as well. Periodic checking of the underside of the roof from the attic after a storm or winter freezing may give early warning of any leaks. Generally, damage from water or ice is less likely on a roof that has good flashing on the outside and is well ventilated and insulated on the inside. Specific instructions for the maintenance of the different roof materials should be available from the architect or contractor.

Summary

The essential ingredients for replacing and maintaining a historic roof are:

- Understanding the historic character of the building and being sympathetic to it.
- Careful examination and recording of the existing roof and any evidence of earlier roofs.
- Consideration of the historic craftsmanship and detailing and implementing them in the renewal wherever visible.
- Supervision of the roofers or maintenance personnel to assure preservation of historic fabric and proper understanding of the scope and detailing of the project.
- Consideration of alternative materials where the original cannot be used.
- Cyclical maintenance program to assure that the staff understands how to take care of the roof and of the particular trouble spots to safeguard.

With these points in mind, it will be possible to preserve the architectural character and maintain the physical integrity of the roofing on a historic building.

This Preservation Brief was written by Sarah M. Sweetser, Architectural Historian, Technical Preservation Services Division. Much of the technical information was based upon an unpublished report prepared under contract for this office by John G. and Diana S. Waite. Some of the historical information was from Charles E. Peterson, FAIA, "American Notes," *Journal of the Society of Architectural Historians*.

The illustrations for this brief not specifically credited are from the files of the Technical Preservation Services Division.

This publication was prepared pursuant to Executive Order 11593, "Protection and Enhancement of the Cultural Environment," which directs the Secretary of the Interior to "develop and make available to Federal agencies and State and local governments information concerning professional methods and tech-

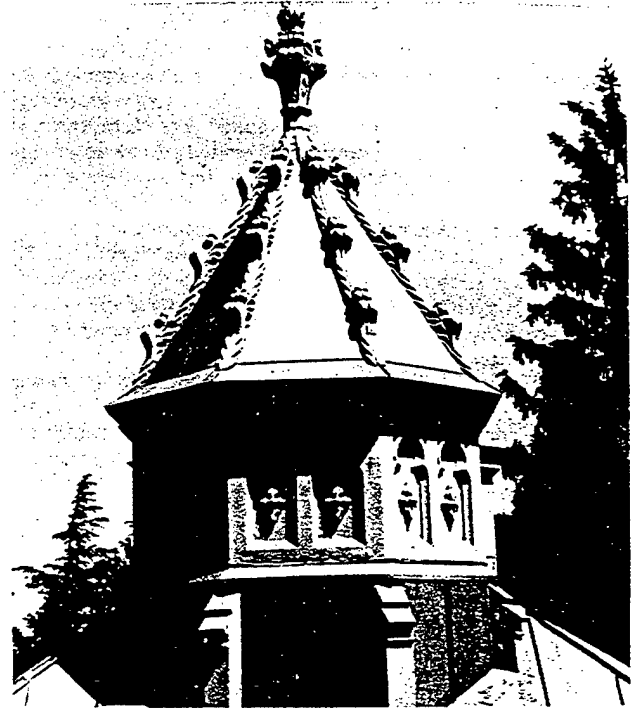

Decorative features such as cupolas require extra maintenance. The flashing is carefully detailed to promote run-off, and the wooden ribbing must be kept well-painted. This roof surface, which was originally tin plate, has been replaced with lead-coated copper for maintenance purposes. (Lyndhurst, Tarrytown, New York, photo courtesy of the National Trust for Historic Preservation)

niques for preserving, improving, restoring and maintaining historic properties." The Brief has been developed under the technical editorship of Lee H. Nelson, AIA, Chief, Preservation Assistance Division, National Park Service, U.S. Department of the Interior, Washington, D.C. 20240. Comments on the usefulness of this information are welcome and can be sent to Mr. Nelson at the above address. This publication is not copyrighted and can be reproduced without penalty. Normal procedures for credit to the author and the National Park Service are appreciated. February 1978.

Additional readings on the subject of roofing are listed below.

- Boaz, Joseph N., ed. *Architectural Graphic Standards*. New York: John Wiley and Sons, Inc., 1970. (Modern roofing types and detailing)
- Briggs, Martin S. *A Short History of the Building Crafts*. London: Oxford University Press, 1925. (Descriptions of historic roofing materials)
- Bulletin of the Association for Preservation Technology*. Vol. 2 (nos. 1-2) 1970. (Entirely on roofing)
- Holstrom, Ingmar; and Sandstrom, Christina. *Maintenance of Old Buildings: Preservation from the Technical and Antiquarian Standpoint*. Stockholm: National Swedish Building Research, 1972. (Contains a section on roof maintenance problems)
- Insall, Donald. *The Care of Old Buildings Today*. London: The Architectural Press, 1972. (Excellent guide to some problems and solutions for historic roofs)
- Labine, R.A. Clem. "Repairing Slate Roofs." *The Old House Journal* 3 (no. 12, Dec. 1975): 6-7.
- Lefer, Henry. "A Birds-eye View." *Progressive Architecture*. (Mar. 1977), pp. 88-92. (Article on contemporary sheet metal)
- National Slate Association. *Slate Roofs*. Reprint of 1926 edition, now available from the Vermont Structural Slate Co., Inc., Fairhaven, VT 05743. (An excellent reference for the many designs and details of slate roofs)
- Peterson, Charles E. "Iron in Early American Roofs." *The Smithsonian Journal of History* 3 (no. 3). Edited by Peter C. Welsh. Washington, D.C.: Smithsonian Institution, 1968, pp. 41-76.
- Waite, Diana S. *Nineteenth Century Tin Roofing and its Use at Hy Hall*. Albany: New York State Historic Trust, 1971.
- . "Roofing for Early America." *Building Early America*. Edited by Charles E. Peterson. Radnor, Penn.: Chilton Book Co., 1976.

6 PRESERVATION BRIEFS

Dangers of Abrasive Cleaning to Historic Buildings

Anne E. Grimmer

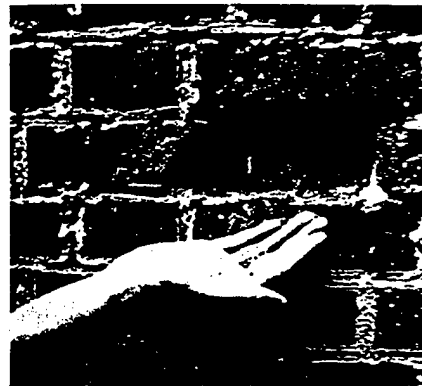

U.S. Department of the Interior National Park Service
Preservation Assistance Division Technical Preservation Services

"The surface cleaning of structures shall be undertaken with the gentlest means possible. Sandblasting and other cleaning methods that will damage the historic building materials shall not be undertaken."—The Secretary of the Interior's "Standards for Historic Preservation Projects."

Abrasive cleaning methods are responsible for causing a great deal of damage to historic building materials. To prevent indiscriminate use of these potentially harmful techniques, this brief has been prepared to explain abrasive cleaning methods, how they can be physically and aesthetically destructive to historic building materials, and why they generally are not acceptable preservation treatments for historic structures. There are alternative, less harsh means of cleaning and removing paint and stains from historic buildings. However, careful testing should precede general cleaning to assure that the method selected will not have an adverse effect on the building materials. A historic building is irreplaceable, and should be cleaned using only the "gentlest means possible" to best preserve it.

What is Abrasive Cleaning?

Abrasive cleaning methods include all techniques that physically abrade the building surface to remove soils, discolorations or coatings. Such techniques involve the use of certain *materials* which impact or abrade the surface under pressure, or abrasive *tools and equipment*. Sand, because it is readily available, is probably the most commonly used type of grit material. However, any of the following materials may be substituted for sand, and all can be classified as abrasive substances: ground slag or volcanic ash, crushed (pulverized) walnut or almond shells, rice husks, ground corncobs, ground coconut shells, crushed eggshells, silica flour, synthetic particles, glass beads and micro-balloons. Even *water* under pressure can be an abrasive substance. Tools and equipment that are abrasive to historic building materials include wire

brushes, rotary wheels, power sanding disks and belt sanders.

The use of water in combination with grit may also be classified as an abrasive cleaning method. Depending on the manner in which it is applied, water *may* soften the impact of the grit, but water that is too highly pressurized can be very abrasive. There are basically two different methods which can be referred to as "wet grit," and it is important to differentiate between the two. One technique involves the addition of a stream of water to a regular sandblasting nozzle. This is done primarily to cut down dust, and has very little, if any, effect on reducing the aggressiveness, or cutting action of the grit particles. With the second technique, a very small amount of grit is added to a pressurized water stream. This method may be controlled by regulating the amount of grit fed into the water stream, as well as the pressure of the water.

Why Are Abrasive Cleaning Methods Used?

Usually, an abrasive cleaning method is selected as an expeditious means of quickly removing years of dirt accumulation, unsightly stains, or deteriorating building fabric or finishes, such as stucco or paint. The fact that sandblasting is one of the best known and most readily available building cleaning treatments is probably the major reason for its frequent use.

Many mid-19th century brick buildings were painted immediately or soon after completion to protect poor quality brick or to imitate another material, such as stone. Sometimes brick buildings were painted in an effort to produce what was considered a more harmonious relationship between a building and its natural surroundings. By the 1870s, brick buildings



Abrasively Cleaned vs. Untouched Brick. Two brick rowhouses with a common façade provide an excellent point of comparison when only one of the houses has been sandblasted. It is clear that abrasive blasting, by removing the outer surface, has left the brickwork on the left rough and pitted, while that on the right still exhibits an undamaged and relatively smooth surface. Note that the abrasive cleaning has also removed a considerable portion of the mortar from the joints of the brick on the left side, which will require repointing.

were often left unpainted as mechanization in the brick industry brought a cheaper pressed brick and fashion decreed a sudden preference for dark colors. However, it was still customary to paint brick of poorer quality for the additional protection the paint afforded.

It is a common 20th-century misconception that all historic masonry buildings were initially unpainted. If the intent of a modern restoration is to return a building to its original appearance, removal of the paint not only may be historically inaccurate, but also harmful. Many older buildings were painted or stuccoed at some point to correct recurring maintenance problems caused by faulty construction techniques, to hide alterations, or in an attempt to solve moisture problems. If this is the case, removal of paint or stucco may cause these problems to reoccur.

Another reason for paint removal, particularly in rehabilitation projects, is to give the building a "new image" in response to contemporary design trends and to attract investors or tenants. Thus, it is necessary to consider the purpose of the intended cleaning. While it is clearly important to remove unsightly stains, heavy encrustations of dirt, peeling paint or other surface coatings, it may not be equally desirable to remove paint from a building which originally was painted. Many historic buildings which show only a slight amount of soil or discoloration are much better left as they are. A thin layer of soil is more often protective of the building fabric than it is harmful, and seldom detracts from the building's



Abrading the Surface without Removing the Paint. Even though the entire outer surface layer of the brick has been sandblasted off, spots of paint still cling to the masonry. Sandblasting or other similarly abrasive methods are not always a successful means of removing paint.

architectural and/or historic character. Too thorough cleaning of a historic building may not only sacrifice some of the building's character, but also, misguided cleaning efforts can cause a great deal of damage to historic building fabric. Unless there are stains, graffiti or dirt and pollution deposits which are destroying the building fabric, it is generally preferable to do as little cleaning as possible, or to repaint where necessary. It is important to remember that a historic building does not have to look as if it were newly constructed to be an attractive or successful restoration or rehabilitation project. For a more thorough explanation of the philosophy of cleaning historic buildings see *Preservation Briefs: No. "The Cleaning and Waterproof Coating of Masonry Buildings,"* by Robert C. Mack, AIA.

Problems of Abrasive Cleaning

The crux of the problem is that abrasive cleaning is just that—abrasive. An abrasively cleaned historic structure may be physically as well as aesthetically damaged. Abrasive methods "clean" by eroding dirt or paint, but at the same time they also tend to erode the surface of the building material. In this way, abrasive cleaning is destructive and causes irreversible harm to the historic building fabric. If the fabric is brick, abrasive methods remove the hard, outer protective surface, and therefore make the brick more susceptible to rapid weathering and deterioration. Grit blasting may also increase the water permeability of a brick wall. The impact of the grit particles tends to erode the bond between the mortar and the brick, leaving cracks or enlarging existing cracks where water can enter. Some types of stone develop a protective patina or "quarry crust" parallel to the worked surface (created by the movement of moisture towards the outer edge), which also may be damaged by abrasive cleaning. The rate at which the material subsequently weathers depends on the quality of the inner surface that is exposed.

Abrasive cleaning can destroy, or substantially diminish, decorative detailing on buildings such as a molded brickwork or architectural terra-cotta, ornamental carving on wood or stone, and evidence of historic craft techniques, such as tool marks and other surface textures. In addition, perfectly sound and/or "tooled" mortar joints can be worn away by abrasive techniques. This not only results in the loss of historic craft detailing but also requires repointing, a step involving col-

siderable time, skill and expense, and which might not have been necessary had a gentler method been chosen. Erosion and pitting of the building material by abrasive cleaning creates a greater surface area on which dirt and pollutants collect. In this sense, the building fabric "attracts" more dirt, and will require more frequent cleaning in the future.

In addition to causing physical and aesthetic harm to the historic fabric, there are several adverse environmental effects of dry abrasive cleaning methods. Because of the friction caused by the abrasive medium hitting the building fabric, these techniques usually create a considerable amount of dust, which is unhealthy, particularly to the operators of the abrasive equipment. It further pollutes the environment around the job site, and deposits dust on neighboring buildings, parked vehicles and nearby trees and shrubbery. Some adjacent materials not intended for abrasive treatment such as wood or glass, may also be damaged because the equipment may be difficult to regulate.

Wet grit methods, while eliminating dust, deposit a messy slurry on the ground or other objects surrounding the base of the building. In colder climates where there is the threat of frost, any wet cleaning process applied to historic masonry structures must be done in warm weather, allowing ample time for the wall to dry out thoroughly before cold weather sets in. Water which remains and freezes in cracks and openings of the masonry surface eventually may lead to spalling. High-pressure wet cleaning may force an inordinate amount of water into the walls, affecting interior materials such as plaster or joist ends, as well as metal building components within the walls.

Variable Factors

The greatest problem in developing practical guidelines for cleaning any historic building is the large number of variable and unpredictable factors involved. Because these variables make each cleaning project unique, it is difficult to establish specific standards at this time. This is particularly true of abrasive cleaning methods because their inherent potential for causing damage is multiplied by the following factors:

- the type and condition of the material being cleaned;
- the size and sharpness of the grit particles or the mechanical equipment;
- the pressure with which the abrasive grit or equipment is applied to the building surface;
- the skill and care of the operator; and
- the constancy of the pressure on all surfaces during the cleaning process.

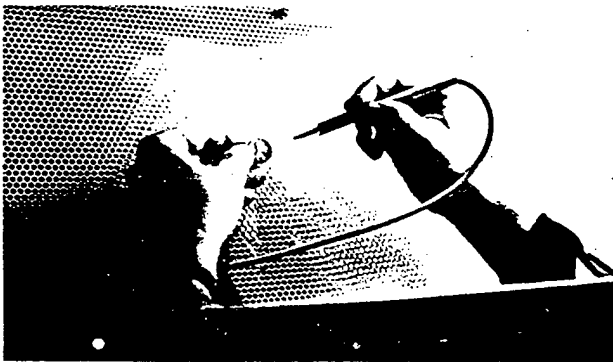

Micro-Abrasive Cleaning. This small, pencil-sized micro-abrasive unit is used by some museum conservators to clean small objects. This particular micro-abrasive unit is operated within the confines of a box (approximately 2 cubic feet of space), but a similar and slightly larger unit may be used for cleaning larger pieces of sculpture, or areas of architectural detailing on a building. Even a pressure cleaning unit this small is capable of eroding a surface, and must be carefully controlled.



"Line Drop." Even though the operator of the sandblasting equipment is standing on a ladder to reach the higher sections of the wall, it is still almost impossible to have total control over the pressure. The pressure of the sand hitting the lower portion of the wall will still be greater than that above, because of the "line drop" in the distance from the pressure source to the nozzle. (Hugh Miller)

Pressure: The damaging effects of most of the variable factors involved in abrasive cleaning are self evident. However, the matter of pressure requires further explanation. In cleaning specifications, pressure is generally abbreviated as "psi" (pounds per square inch), which technically refers to the "tip" pressure, or the amount of pressure at the nozzle of the blasting apparatus. Sometimes "psig," or pressure at the gauge (which may be many feet away, at the other end of the hose), is used in place of "psi." These terms are often incorrectly used interchangeably.

Despite the apparent care taken by most architects and building cleaning contractors to prepare specifications for pressure cleaning which will not cause harm to the delicate fabric of a historic building, it is very difficult to ensure that the same amount of pressure is applied to all parts of the building. For example, if the operator of the pressure equipment stands on the ground while cleaning a two-story structure, the amount of force reaching the first story will be greater than that hitting the second story, even if the operator stands on scaffolding or in a cherry picker, because of the "line drop" in the distance from the pressure source to the nozzle. Although technically it may be possible to prepare cleaning specifications with tight controls that would eliminate all but a small margin of error, it may not be easy to find professional cleaning firms willing to work under such restrictive conditions. The fact is that many professional building cleaning firms do not really understand the extreme delicacy of historic building fabric, and how it differs from modern construction materials. Consequently, they may ac-

cept building cleaning projects for which they have no experience.

The amount of pressure used in any kind of cleaning treatment which involves pressure, whether it is dry or wet grit, chemicals or just plain water, is crucial to the outcome of the cleaning project. Unfortunately, no standards have been established for determining the correct pressure for cleaning each of the many historic building materials which would not cause harm. The considerable discrepancy between the way the building cleaning industry and architectural conservators define "high" and "low" pressure cleaning plays a significant rôle in the difficulty of creating standards.

Nonhistoric/Industrial: A representative of the building cleaning industry might consider "high" pressure water cleaning to be anything over 5,000 psi, or even as high as 10,000 to 15,000 psi! Water under this much pressure may be necessary to clean industrial structures or machinery, but would destroy most historic building materials. Industrial chemical cleaning commonly utilizes pressures between 1,000 and 2,500 psi.



Spalling Brick. This soft, early 19th-century brick was sandblasted in the 1960s; consequently, severe spalling has resulted. Some bricks have almost totally disintegrated, and will eventually have to be replaced. (Robert S. Gamble)

Historic: By contrast, conscientious dry or wet abrasive cleaning of a historic structure would be conducted within the range of 20 to 100 psi at a range of 3 to 12 inches. Cleaning at this low pressure requires the use of a very fine 00 or 0 mesh grit forced through a nozzle with a 1/4 inch opening. A similar, even more delicate method being adopted by architectural conservators uses a micro-abrasive grit on small, hard-to-clean areas of carved, cut or molded ornament on a building facade. Originally developed by museum conservators for cleaning sculpture, this technique may employ glass beads, micro-balloons, or another type of micro-abrasive gently powered at approximately 40 psi by a very small, almost pencil-like pressure instrument. Although a slightly larger pressure instrument may be used on historic buildings, this technique still has limited practical applicability on a large scale building cleaning project because of the cost and the relatively few technicians competent to handle the task. In general, architectural conservators have determined that only through very controlled conditions can most historic building material be abrasively cleaned of soil or paint without measurable damage to the surface or profile of the substrate.

Yet some professional cleaning companies which specialize in cleaning historic masonry buildings use chemicals and water at a pressure of approximately 1,500 psi, while other cleaning firms recommend lower pressures ranging from 200 to 800 psi for a similar project. An architectural conservator might decide, *after testing*, that some historic structures could be cleaned properly using a moderate pressure (200-600 psi), or even a high pressure (600-1800 psi) water rinse. However,

cleaning historic buildings under such high pressure should be considered an exception rather than the rule, and would require *very careful* testing and supervision to assure that the historic surface materials could withstand the pressure without gouging, pitting or loosening.

These differences in the amount of pressure used by commercial or industrial building cleaners and architectural conservators point to one of the main problems in using abrasive means to clean historic buildings: misunderstanding of the potentially fragile nature of historic building materials. There is no one cleaning formula or pressure suitable for all situations. Decisions regarding the proper cleaning process for historic structures can be made only after careful analysis of the building fabric, and testing.

How Building Materials React to Abrasive Cleaning Methods

Brick and Architectural Terra-Cotta: Abrasive blasting does not affect all building materials to the same degree. Such techniques quite logically cause greater damage to softer and more porous materials, such as brick or architectural terra-cotta. When these materials are cleaned abrasively, the hard, outer layer (closest to the heat of the kiln) is eroded, leaving the soft, inner core exposed and susceptible to accelerated weathering. Glazed architectural terra-cotta and ceramic veneer have a baked-on glaze which is also easily damaged by abrasive cleaning. Glazed architectural terra-cotta was designed for easy maintenance, and generally can be cleaned using detergent and water; but chemicals or steam may be needed to remove more persistent stains. Large areas of brick or architectural terra-cotta which have been painted are best left painted, or repainted if necessary.

Plaster and Stucco: Plaster and stucco are types of masonry finish materials that are softer than brick or terra-cotta: treated abrasively these materials will simply disintegrate. Indeed, when plaster or stucco is treated abrasively it is usually with the intention of removing the plaster or stucco from whatever base material or substrate it is covering. Obviously, such abrasive techniques should not be applied to clean sound plaster or stuccoed walls, or decorative plaster wall surfaces.

Building Stones: Building stones are cut from the three main categories of natural rock: dense, igneous rock such as granite; sandy, sedimentary rock such as limestone or sandstone; and crystalline, metamorphic rock such as marble. As op-



Abrasive Cleaning of Tooled Granite. Even this carefully controlled, "wet grit" blasting has erased vertical tooling marks in the cut granite blocks on the left. Not only has the tooling been destroyed, but damaged stone surface is now more susceptible to accelerated weathering.

posed to kiln-dried masonry materials such as brick and architectural terra-cotta, building stones are generally homogeneous in character at the time of a building's construction. However, as the stone is exposed to weathering and environmental pollutants, the surface may become friable, or may develop a protective skin or patina. These outer surfaces are very susceptible to damage by abrasive or improper chemical cleaning.

Building stones are frequently cut into ashlar blocks or "dressed" with tool marks that give the building surface a specific texture and contribute to its historic character as much as ornately carved decorative stonework. Such detailing is easily damaged by abrasive cleaning techniques; the pattern of tooling or cutting is erased, and the crisp lines of moldings or carving are worn or pitted.

Occasionally, it may be possible to clean small areas of rough-cut granite, limestone or sandstone having a heavy dirt encrustation by using the "wet grit" method, whereby a small amount of abrasive material is injected into a controlled, pressurized water stream. However, this technique requires very careful supervision in order to prevent damage to the stone. Polished or honed marble or granite should *never* be treated abrasively, as the abrasion would remove the finish in much the way glass would be etched or "frosted" by such a process. It is generally preferable to underclean, as too strong a cleaning procedure will erode the stone, exposing a new and increased surface area to collect atmospheric moisture and dirt. Removing paint, stains or graffiti from most types of stone may be accomplished by a chemical treatment carefully selected to best handle the removal of the particular type of paint or stain without damaging the stone. (See section on the "Gentlest Means Possible")



Abrasive Cleaning of Wood. This wooden windowsill, molding and paneling have been sandblasted to remove layers of paint in the rehabilitation of this commercial building. Not only is some paint still embedded in cracks and crevices of the woodwork, but more importantly, grit blasting has actually eroded the summer wood, in effect raising the grain, and resulting in a rough surface.

Wood: Most types of wood used for buildings are soft, fibrous and porous, and are particularly susceptible to damage by abrasive cleaning. Because the summer wood between the lines of the grain is softer than the grain itself, it will be worn away by abrasive blasting or power tools, leaving an uneven surface with the grain raised and often frayed or "fuzzy." Once this has occurred, it is almost impossible to achieve a smooth surface again except by extensive hand sanding, which is expensive and will quickly negate any costs saved earlier by sandblasting. Such harsh cleaning treatment also obliterates historic tool marks, fine carving and detailing, which precludes its use on any interior or exterior woodwork which has been hand planed, milled or carved.

Metals: Like stone, metals are another group of building materials which vary considerably in hardness and durability. Softer metals which are used architecturally, such as tin, zinc, lead, copper or aluminum, generally should not be cleaned abrasively as the process deforms and destroys the original surface texture and appearance, as well as the acquired patina. Much applied architectural metal work used on historic buildings—tin, zinc, lead and copper—is often quite thin and soft, and therefore susceptible to denting and pitting. Galvanized sheet metal is especially vulnerable, as abrasive treatment would wear away the protective galvanized layer.

In the late 19th and early 20th centuries, these metals were often cut, pressed or otherwise shaped from sheets of metal into a wide variety of practical uses such as roofs, gutters and flashing, and façade ornamentation such as cornices, friezes, dormers, panels, cupolas, oriel windows, etc. The architecture of the 1920s and 1930s made use of metals such as chrome, nickel alloys, aluminum and stainless steel in decorative exterior panels, window frames, and doorways. Harsh abrasive blasting would destroy the original surface finish of most of these metals, and would increase the possibility of corrosion.

However, conservation specialists are now employing a sensitive technique of glass bead peening to clean some of the harder metals, in particular large bronze outdoor sculpture. Very fine (75–125 micron) glass beads are used at a low pressure of 60 to 80 psi. Because these glass beads are completely spherical, there are no sharp edges to cut the surface of the metal. After cleaning, these statues undergo a lengthy process of polishing. Coatings are applied which protect the surface from corrosion, but they must be renewed every 3 to 5 years. A similarly delicate cleaning technique employing glass beads has been used in Europe to clean historic masonry structures without causing damage. But at this time the process has not been tested sufficiently in the United States to recommend it as a building conservation measure.

Sometimes a very fine *smooth* sand is used at a low pressure to clean or remove paint and corrosion from copper flashing and other metal building components. Restoration architects recently found that a mixture of crushed walnut shells and copper slag at a pressure of approximately 200 psi was the only way to remove corrosion successfully from a mid-19th century terne-coated iron roof. Metal cleaned in this manner must be painted immediately to prevent rapid recurrence of corrosion. It is thought that these methods "work harden" the surface by compressing the outer layer, and actually may be good for the surface of the metal. But the extremely complex nature and the time required by such processes make it very expensive and impractical for large-scale use at this time.

Cast and wrought iron architectural elements may be gently sandblasted or abrasively cleaned using a wire brush to remove layers of paint, rust and corrosion. Sandblasting was, in fact, developed originally as an efficient maintenance procedure for engineering and industrial structures and heavy machinery—iron and steel bridges, machine tool frames, engine frames, and railroad rolling stock—in order to clean and prepare them for repainting. Because iron is hard, its surface,

which is naturally somewhat uneven, will not be noticeably damaged by controlled abrasion. Such treatment will, however, result in a small amount of pitting. But this slight abrasion creates a good surface for paint, since the iron must be repainted immediately to prevent corrosion. Any abrasive cleaning of metal building components will also remove the caulking from joints and around other openings. Such areas must be recaulked quickly to prevent moisture from entering and rusting the metal, or causing deterioration of other building fabric inside the structure.

When is Abrasive Cleaning Permissible?

For the most part, abrasive cleaning is destructive to historic building materials. A limited number of special cases have been explained when it may be appropriate, if supervised by a skilled conservator, to use a delicate abrasive technique on some historic building materials. The type of "wet grit" cleaning which involves a small amount of grit injected into a stream of low pressure water may be used on small areas of stone masonry (i.e., rough cut limestone, sandstone or unpolished granite), where milder cleaning methods have not been totally successful in removing harmful deposits of dirt and pollutants. Such areas may include stone window sills, the tops of cornices or column capitals, or other detailed areas of the façade.

This is still an abrasive technique, and without proper caution in handling, it can be *just as harmful to the building surface as any other abrasive cleaning method*. Thus, the decision to use this type of "wet grit" process should be made only after consultation with an experienced building conservator. Remember that *it is very time consuming and expensive to use any abrasive technique on a historic building in such a manner that it does not cause harm to the often fragile and friable building materials*.

At this time, and only under certain circumstances, abrasive cleaning methods may be used in the rehabilitation of interior spaces of warehouse or industrial buildings for contemporary uses.

Interior spaces of factories or warehouse structures in which the masonry or plaster surfaces do not have significant design, detailing, tooling or finish, and in which wooden architectural features are not finished, molded, beaded or worked by hand, may be cleaned abrasively in order to remove layers of paint and industrial discolorations such as smoke, soot, etc. It is expected after such treatment that brick surfaces will be rough and pitted, and wood will be somewhat frayed or "fuzzy"



Permissible Abrasive Cleaning. In accordance with the Secretary of the Interior's Guidelines for Rehabilitation Projects, it may be acceptable to use abrasive techniques to clean an industrial interior space such as that illustrated here, because the masonry surfaces do not have significant design, detailing, tooling or finish, and the wooden architectural features are not finished, molded, beaded or worked by hand.

with raised wood grain. These nonsignificant surfaces will be damaged and have a roughened texture, but because they are interior elements, they will not be subject to further deterioration caused by weathering.

Historic Interiors that Should Not Be Cleaned Abrasively

Those instances (generally industrial and some commercial properties), when it may be acceptable to use an abrasive treatment on the interior of historic structures have been described. But for the majority of historic buildings, the Secretary of the Interior's *Guidelines for Rehabilitation* do not recommend "changing the texture of exposed wooden architectural features (including structural members) and masonry surfaces through sandblasting or use of other abrasive techniques to remove paint, discolorations and plaster. . . ."

Thus, it is not acceptable to clean abrasively interiors of historic residential and commercial properties which have *finished* interior spaces featuring milled woodwork such as doors, window and door moldings, wainscoting, stair balustrades and mantelpieces. Even the most modest historic *house* interior, although it may not feature elaborate detailing, contains plaster and woodwork that is architecturally significant to the original design and function of the house. Abrasive cleaning of such an interior would be destructive to the historic integrity of the building.

Abrasive cleaning is also impractical. Rough surfaces of abrasively cleaned wooden elements are hard to keep clean. It is also difficult to seal, paint or maintain these surfaces which can be splintery and a problem to the building's occupants. The force of abrasive blasting may cause grit particles to lodge in cracks of wooden elements, which will be a nuisance as the grit is loosened by vibrations and gradually sifts out. Removal of plaster will reduce the thermal and insulating value of the walls. Interior brick is usually softer than exterior brick, and generally of a poorer quality. Removing surface plaster from such brick by abrasive means often exposes gaping mortar joints and mismatched or repaired brickwork which was never intended to show. The resulting bare brick wall may require repointing, often difficult to match. It also may be necessary to apply a transparent surface coating (or sealer) in order to prevent the mortar and brick from "dusting." However, a sealer may not only change the color of the brick, but may also compound any existing moisture problems by restricting the normal evaporation of water vapor from the masonry surface.

"Gentlest Means Possible"

There are alternative means of removing dirt, stains and paint from historic building surfaces that can be recommended as more efficient and less destructive than abrasive techniques. The "gentlest means possible" of removing dirt from a building surface can be achieved by using a low-pressure water wash, scrubbing areas of more persistent grime with a natural bristle (never metal) brush. Steam cleaning can also be used effectively to clean some historic building fabric. Low-pressure water or steam will soften the dirt and cause the deposits to rise to the surface, where they can be washed away.

A third cleaning technique which may be recommended to remove dirt, as well as stains, graffiti or paint, involves the use of commercially available chemical cleaners or paint removers, which, when applied to masonry, loosen or dissolve the dirt or stains. These cleaning agents may be used in combination with water or steam, followed by a clear water wash to remove the residue of dirt and the chemical cleaners from the masonry. A natural bristle brush may also facilitate the type of chemically assisted cleaning, particularly in areas of heavy dirt deposits or stains, and a wooden scraper can be

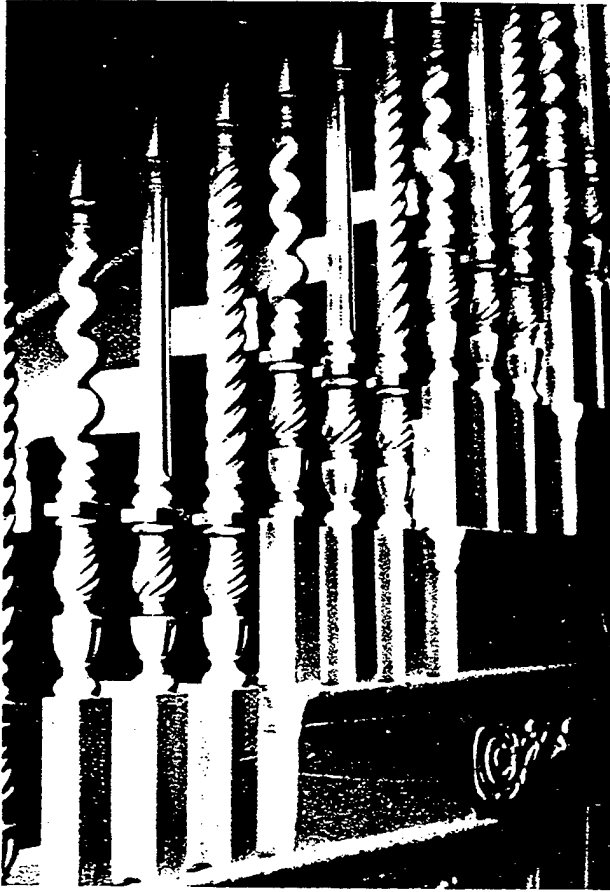

Do not Abrasively Clean these Interiors. Most historic residential and some commercial interior spaces contain finished plaster and wooden elements such as this stair balustrade and paneling which contribute to the historic and architectural character of the structure. Such interiors should not be subjected to abrasive techniques for the purpose of removing paint, dirt, discoloration or plaster.

useful in removing thick encrustations of soot. A limewash or absorbent talc, whitening or clay poultice with a solvent can be used effectively to draw out salts or stains from the surface of the selected areas of a building façade. It is almost impossible to remove paint from masonry surfaces without causing some damage to the masonry, and it is best to leave the surfaces as they are or repaint them if necessary.

Some physicists are experimenting with the use of pulsed laser beams and xenon flash lamps for cleaning historic masonry surfaces. At this time it is a slow, expensive cleaning method, but its initial success indicates that it may have an increasingly important role in the future.

There are many chemical paint removers which, when applied to painted wood, soften and dissolve the paint so that it can be scraped off by hand. Peeling paint can be removed from wood by hand scraping and sanding. Particularly thick layers of paint may be softened with a heat gun or heat plate, providing appropriate precautions are taken, and the paint film scraped off by hand. Too much heat applied to the same spot can burn the wood, and the fumes caused by burning paint are dangerous to inhale, and can be explosive. Furthermore, the hot air from heat guns can start fires in the building cavity. Thus, adequate ventilation is important when using a heat gun or heat plate, as well as when using a chemical stripper. A torch or open flame should never be used.

Preparations for Cleaning: It cannot be overemphasized that all of these cleaning methods must be approached with cau-

tion. When using any of these procedures which involve water or other liquid cleaning agents on masonry, it is imperative that *all* openings be tightly covered, and all cracks or joints be well pointed in order to avoid the danger of water penetrating the building's façade, a circumstance which might result in serious moisture related problems such as efflorescence and/or subflorescence. Any time water is used on masonry as a cleaning agent, either in its pure state or in combination with chemical cleaners, it is very important that the work be done in warm weather when there is no danger of frost for several months. Otherwise water which has penetrated the masonry may freeze, eventually causing the surface of the building to crack and spall, which may create another conservation problem more serious to the health of the building than dirt.

Each kind of masonry has a unique composition and reacts differently with various chemical cleaning substances. Water and/or chemicals may interact with minerals in stone and cause new types of stains to leach out to the surface immediately, or more gradually in a delayed reaction. What may be a safe and effective cleaner for certain stain on one type of stone, may leave unattractive discolorations on another stone, or totally dissolve a third type.

Testing: Cleaning historic building materials, particularly masonry, is a technically complex subject, and thus, should never be done without expert consultation and testing. No cleaning project should be undertaken without first applying the intended cleaning agent to a representative test patch area in an inconspicuous location on the building surface. The test patch or patches should be allowed to weather for a period of time, preferably through a complete seasonal cycle, in order to determine that the cleaned area will not be adversely affected by wet or freezing weather or any by-products of the cleaning process.

Mitigating the Effects of Abrasive Cleaning

There are certain restoration measures which can be adopted to help preserve a historic building exterior which has been damaged by abrasive methods. Wood that has been sandblasted will exhibit a frayed or "fuzzed" surface, or a harder wood will have an exaggerated raised grain. The only way to remove this rough surface or to smooth the grain is by laborious sanding. Sandblasted wood, unless it has been extensively sanded, serves as a dustcatcher, will weather faster, and will present a continuing and ever worsening maintenance problem. Such wood, after sanding, should be painted or given a clear surface coating to protect the wood, and allow for somewhat easier maintenance.

There are few successful preservative treatments that may be applied to grit-blasted exterior masonry. Harder, denser stone may have suffered only a loss of crisp edges or tool marks, or other indications of craft technique. If the stone has a compact and uniform composition, it should continue to weather with little additional deterioration. But some types of sandstone, marble and limestone will weather at an accelerated rate once their protective "quarry crust" or patina has been removed.

Softer types of masonry, particularly brick and architectural terra-cotta, are the most likely to require some remedial treatment if they have been abrasively cleaned. Old brick, being essentially a soft, baked clay product, is greatly susceptible to increased deterioration when its hard, outer skin is removed through abrasive techniques. This problem can be minimized by painting the brick. An alternative is to treat it with a clear sealer or surface coating but this will give the masonry a glossy or shiny look. It is usually preferable to paint the brick rather than to apply a transparent sealer since

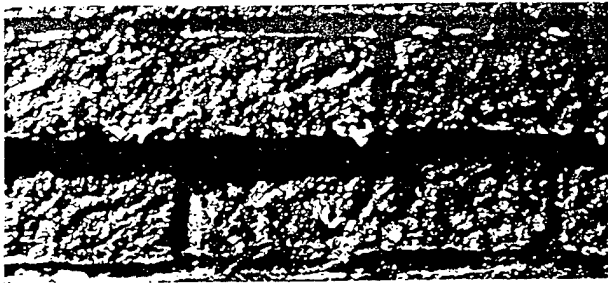

Hazards of Sandblasting and Surface Coating. In order to "protect" this heavily sandblasted brick, a clear surface coating or sealer was applied. Because the air temperature was too cold at the time of application, the sealer failed to dry properly, dripping in places, and giving the brick surface a cloudy appearance.

sealers reduce the transpiration of moisture, allowing salts to crystallize as subflorescence that eventually spalls the brick. If a brick surface has been so extensively damaged by abrasive cleaning and weathering that spalling has already begun, it may be necessary to cover the walls with stucco, if it will adhere.

Of course, the application of paint, a clear surface coating (sealer), or stucco to deteriorating masonry means that the historical appearance will be sacrificed in an attempt to conserve the historic building materials. However, the original color and texture will have been changed already by the abrasive treatment. At this point it is more important to try to preserve the brick, and there is little choice but to protect it from "dusting" or spalling too rapidly. As a last resort, in the case of severely spalling brick, there may be no option but to replace the brick—a difficult, expensive (particularly if custom-made reproduction brick is used), and lengthy process. As described earlier, sandblasted interior brick work, while not subject to change of weather, may require the application of a transparent surface coating or painting as a maintenance procedure to contain loose mortar and brick dust. (See Preservation Briefs: No. 1 for a more thorough discussion of coatings.)

Metals, other than cast or wrought iron, that have been pitted and dented by harsh abrasive blasting usually cannot be smoothed out. Although fillers may be satisfactory for smoothing a painted surface, exposed metal that has been damaged usually will have to be replaced.

Summary

Sandblasting or other abrasive methods of cleaning or paint removal are by their nature destructive to historic building materials and should not be used on historic buildings except in a few well-monitored instances. There are exceptions when certain types of abrasive cleaning may be permissible, but only if conducted by a trained conservator, and if cleaning is necessary for the preservation of the historic structure.

There is no one formula that will be suitable for cleaning all historic building surfaces. Although there are many commercial cleaning products and methods available, it is impossible to state definitively which of these will be the most effective without causing harm to the building fabric. It is often difficult to identify ingredients or their proportions contained in cleaning products; consequently it is hard to predict how a product will react to the building materials to be cleaned. Similar uncertainties affect the outcome of other cleaning methods as they are applied to historic building materials. Further advances in understanding the complex nature of the many variables of the cleaning techniques may someday provide a better and simpler solution to the problems. But until that time, the process of cleaning historic buildings must be approached with caution through trial and error.

It is important to remember that historic building materials are neither indestructible, nor are they renewable. They must be treated in a responsible manner, which may mean little or no cleaning at all if they are to be preserved for future generations to enjoy. If it is in the best interest of the building to clean it, then it should be done "using the gentlest means possible."



Selected Reading List

- Ashurst, John. *Cleaning Stone and Brick*. Technical Pamphlet 4. London: Society for the Protection of Ancient Buildings, 1977.
- Asmus, John F. "Light Cleaning: Laser Technology for Surface Preparation in the Arts." *Technology and Conservation*, 3: 3 (Fall 1978), pp. 14-18.
- "The Bare-Brick Mistake." *The Old House Journal*, 1: 2 (November 1973), p. 2.
- Brick Institute of America. *Colorless Coatings for Brick Masonry*. Technical Notes on Brick Construction, Number 7E (September/October 1976).
- Gilder, Cornelia Brooke. *Property Owner's Guide to the Maintenance and Repair of Stone Buildings*. Technical Series No. 5. Albany, New York: The Preservation League of New York State, 1977.
- Prudon, Theodore H.M. "The Case Against Removing Paint from Brick Masonry." *The Old House Journal*, 11: 2 (February 1975), pp. 6-7.
- . "Removing Stains from Masonry." *The Old House Journal*, 5: 5 (May 1977), pp. 58-59.
- Stambolov, T., and J.R.J. Van Asperen de Boer. *The Deterioration and Conservation of Porous Building Materials in Monuments: A Review of the Literature*. Second enlarged edition. Rome: International Centre for Conservation, 1976.

Weiss, Norman R. "Cleaning of Building Exteriors: Problems and Procedures of Dirt Removal." *Technology and Conservation*, 2/76 (Fall 1976), pp. 8-13.

———. *Exterior Cleaning of Historic Masonry Buildings*. Draft. Washington, D.C.: Office of Archeology and Historic Preservation, Heritage Conservation and Recreation Service, U.S. Department of the Interior, 1976.

This Preservation Brief was written by Anne E. Grimmer, Architectural Historian, Technical Preservation Services Division. Valuable suggestions and comments were made by Hugh C. Miller, AIA, Washington, D.C.; Martin E. Weaver, Ottawa, Ontario, Canada; Terry Bryant, Downers Grove, Illinois; Daniel C. Cammer, McLean, Virginia; and the professional staff of Technical Preservation Services Division. Deborah Cooney edited the final manuscript.

The illustrations for this brief not specifically credited are from the files of the Technical Preservation Services Division.

This publication was prepared pursuant to Executive Order 11593, "Protection and Enhancement of the Cultural Environment," which directs the Secretary of the Interior to "develop and make available to Federal agencies and State and local governments information concerning professional methods and techniques for preserving, improving, restoring and maintaining historic properties." The Brief has been developed under the technical editorship of Lee Nelson, AIA, Chief, Preservation Assistance Division, National Park Service, U.S. Department of the Interior, Washington, D.C. 20240. Comments on the usefulness of this information are welcome and can be sent to Mr. Nelson at the above address. This publication is not copyrighted and can be reproduced without penalty. Normal procedures for credit to the author and the National Park Service are appreciated. June 1979.

10 PRESERVATION BRIEFS



Exterior Paint Problems on Historic Woodwork

Kay D. Weeks and David W. Look, AIA

U.S. Department of the Interior National Park Service
Preservation Assistance Division Technical Preservation Services

A cautionary approach to paint removal is included in the guidelines to "The Secretary of the Interior Standards for Historic Preservation Projects." Removing paints down to bare wood surfaces using harsh methods can permanently damage those surfaces; therefore such methods are not recommended. Also, total removal obliterates evidence of the historical paints and their sequence and architectural context.

This Brief expands on that advice for the architect, building manager, contractor, or homeowner by identifying and describing common types of paint surface conditions and failures, then recommending appropriate treatments for preparing exterior wood surfaces for repainting¹ to assure the best adhesion and greatest durability of the new paint. Although the Brief focuses on responsible methods "paint removal," several paint surface conditions will be described which do not require any paint removal, and still others which can be successfully handled by limited paint removal. In all cases, the information is intended to address the concerns related to *exterior wood*. It will also be generally assumed that, because houses built before 1950 involve one or more layers of lead-base paint,² the majority of conditions warranting paint removal will mean dealing with this toxic substance along with the dangers of the paint removal tools and chemical strippers themselves.

Purposes of Exterior Paint

Paint³ applied to exterior wood must withstand yearly extremes of both temperature and humidity. While never expected to be more than a temporary physical shield—requiring re-application every 5-8 years—its importance should not be minimized. Because one of the main causes of wood deterioration is moisture penetration, a primary purpose for painting wood is to exclude such moisture, thereby slowing deterioration not only of a building's exterior siding and decorative features but, ultimately, its underlying structural members. Another important purpose for painting wood is, of course, to define and accent architectural features and to improve appearance.

Treating Paint Problems in Historic Buildings

Exterior paint is constantly deteriorating through the processes of weathering, but in a program of regular maintenance—assuming all other building systems are functioning properly—surfaces can be cleaned, lightly scraped, and hand sanded in preparation for a new finish coat. Unfortunately, these are ideal conditions. More often, complex maintenance problems are inherited by owners of

historic buildings, including areas of paint that have failed⁴ beyond the point of mere cleaning, scraping, and hand sanding (although much so-called "paint failure" is attributable to interior or exterior moisture problems or surface preparation and application mistakes with previous coats).

Although paint problems are by no means unique to historic buildings, treating multiple layers of hardened, brittle paint on complex, ornamental—and possibly fragile—exterior wood surfaces necessarily requires an extremely cautious approach (see figure 1). In the case of recent construction, this level of concern is not needed because the wood is generally less detailed and, in addition, retention of the sequence of paint layers as a partial record of the building's history is not an issue.

When historic buildings are involved, however, a special set of problems arises—varying in complexity depending upon their age, architectural style, historical importance, and physical soundness of the wood—which must be carefully evaluated so that decisions can be made that are sensitive to the longevity of the resource.

Justification for Paint Removal

At the outset of this Brief, it must be emphasized that removing paint from historic buildings—with the exception of cleaning, light scraping, and hand sanding as part of routine maintenance—should be avoided unless absolutely essential. *Once conditions warranting removal have*

¹ General paint type recommendations will be made, but paint color recommendations are beyond the scope of this Brief.

² Douglas R. Shier and William Hall, *Analysis of Housing Data Collected in a Lead-Based Paint Survey in Pittsburgh, Pennsylvania. Part 1*, National Bureau of Standards, Inter-Report 77-1250, May 1977.

³ Any pigmented liquid, liquefiable, or mastic composition designed for application to a substrate in a thin layer which is converted to an opaque solid film after application. *Paint and Coatings Dictionary*, 1978. Federation of Societies for Coatings and Technology.

⁴ For purposes of the Brief, this includes any area of painted exterior woodwork displaying signs of peeling, cracking, or alligatoring to bare wood. See descriptions of these and other paint surface conditions as well as recommended treatments on pp. 5-10.



Fig. 1 Excessive paint build-up on architectural details such as this ornamental bracket does not in itself justify total paint removal. If paint is cracked and peeling down to bare wood, however, it should be removed using the gentlest means possible. Photo: David W. Look, AIA.

been identified, the general approach should be to remove paint to the next sound layer using the gentlest means possible, then to repaint (see figure 2). Practically speaking as well, paint can adhere just as effectively to existing paint as to bare wood, providing the previous coats of paint are also adhering uniformly and tightly to the wood and the surface is properly prepared for repainting—cleaned of dirt and chalk and dulled by sanding. But, if painted exterior wood surfaces display continuous patterns of deep cracks or if they are extensively blistering and peeling so that bare wood is visible, then the old paint should be completely removed before repainting. The only other justification for removing all previous layers of paint is if doors, shutters, or windows have literally been “painted shut,” or if new wood is being pieced-in adjacent to old painted wood and a smooth transition is desired (see figure 3).

Paint Removal Precautions

Because paint removal is a difficult and painstaking process, a number of costly, regrettable experiences have occurred—and continue to occur—for both the historic building and the building owner. Historic buildings have been set on fire with blow torches; wood irreversibly scarred by sandblasting or by harsh mechanical devices such as rotary sanders and rotary wire strippers; and layers of historic paint inadvertently and unnecessarily removed. In addition, property owners, using techniques that substitute speed for safety, have been injured by toxic lead vapors or dust from the paint they were trying to

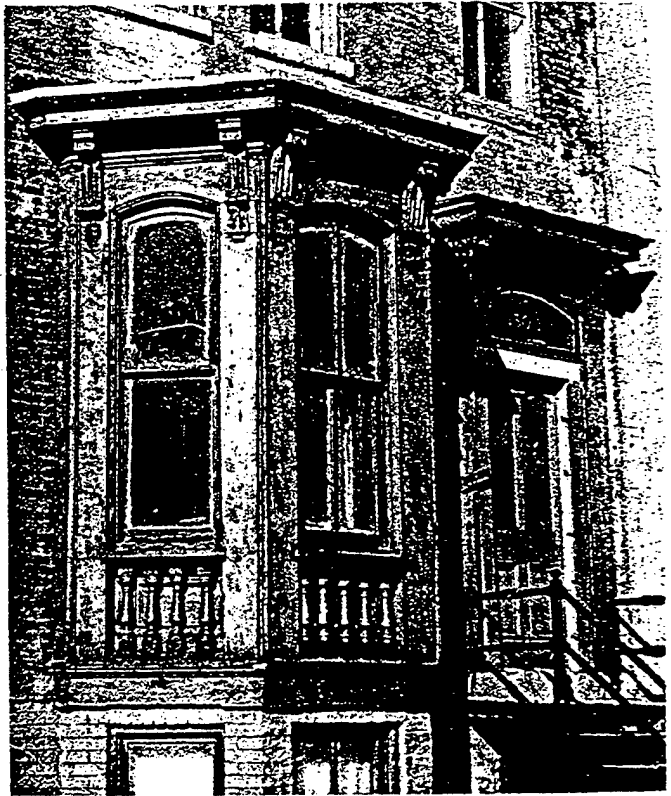

Fig. 2 A traditionally painted bay window has been stripped to bare wood, then varnished. In addition to being historically inaccurate, the varnish will break down faster as a result of the sun's ultraviolet rays than would primer and finish coats of paint. Photo: David W. Look, AIA.

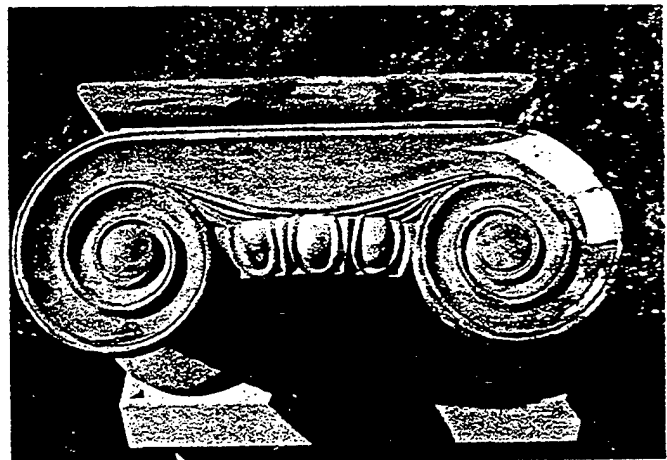

Fig. 3 If damage to parts of a wooden element is severe, new sections of wood will need to be pieced-in. When such piecing is required, paint on the adjacent woodwork should be removed so that the old and new woods will make a smooth profile when joined. After repainting, the repair should be virtually impossible to detect. Photo: Morgan W. Phillips.

remove or by misuse of the paint removers themselves.

Owners of historic properties considering paint removal should also be aware of the amount of time and labor involved. While removing damaged layers of paint from a door or porch railing might be readily accomplished within a reasonable period of time by one or two people, removing paint from larger areas of a building can, with-

out professional assistance, easily become unmanageable and produce less than satisfactory results. The amount of work involved in any paint removal project must therefore be analyzed on a case-by-case basis. Hiring qualified professionals will often be a cost-effective decision due to the expense of materials, the special equipment required, and the amount of time involved. Further, paint removal companies experienced in dealing with the inherent health and safety dangers of paint removal should have purchased such protective devices as are needed to mitigate any dangers and should also be aware of State or local environmental and/or health regulations for hazardous waste disposal.

All in all, paint removal is a messy, expensive, and potentially dangerous aspect of rehabilitating or restoring historic buildings and should not be undertaken without careful thought concerning first, its necessity, and second, which of the available recommended methods is the safest and most appropriate for the job at hand.

Repainting Historic Buildings for Cosmetic Reasons

If existing exterior paint on wood siding, eaves, window sills, sash, and shutters, doors, and decorative features shows no evidence of paint deterioration such as chalking, blistering, peeling, or cracking, then there is no *physical reason* to repaint, much less remove paint! Nor is color fading, of itself, sufficient justification to repaint a historic building.

The decision to repaint may not be based altogether on paint failure. Where there is a new owner, or even where ownership has remained constant through the years, taste in colors often changes. Therefore, if repainting is primarily to alter a building's primary and accent colors, a technical factor of paint accumulation should be taken into consideration. When paint builds up to a thickness of approximately 1/16" (approximately 16-30 layers), one or more extra coats of paint may be enough to trigger cracking and peeling in limited or even widespread areas of the building's surface. This results because excessively thick paint is less able to withstand the shrinkage or pull of an additional coat as it dries and is also less able to tolerate thermal stresses. Thick paint invariably fails at the weakest point of adhesion—the oldest layers next to the wood. Cracking and peeling follow. Therefore, if there are no signs of paint failure, it may be somewhat risky to add still another layer of unneeded paint simply for color's sake (extreme changes in color may also require more than one coat to provide proper hiding power and full color). When paint appears to be nearing the critical thickness, a change of accent colors (that is, just to limited portions of the trim) might be an acceptable compromise without chancing cracking and peeling of paint on wooden siding.

If the decision to repaint is nonetheless made, the "new" color or colors should, at a minimum, be appropriate to the style and setting of the building. On the other hand, where the intent is to restore or accurately reproduce the colors originally used or those from a significant period in the building's evolution, they should be based on the results of a paint analysis.⁵

Identification of Exterior Paint Surface Conditions/Recommended Treatments

It is assumed that a preliminary check will already have been made to determine, first, that the painted exterior surfaces are indeed wood—and not stucco, metal, or other wood substitutes—and second, that the wood has not decayed so that repainting would be superfluous. For example, if any area of bare wood such as window sills has been exposed for a long period of time to standing water, wood rot is a strong possibility (see figure 4). Repair or replacement of deteriorated wood should take place before repainting. After these two basic issues have been resolved, the surface condition identification process may commence.

The historic building will undoubtedly exhibit a variety of exterior paint surface conditions. For example, paint on the wooden siding and doors may be adhering firmly; paint on the eaves peeling; and paint on the porch balusters and window sills cracking and alligating. The accurate identification of each paint problem is therefore the first step in planning an appropriate overall solution.

Paint surface conditions can be grouped according to their relative severity: CLASS I conditions include minor blemishes or dirt collection and generally require *no* paint removal; CLASS II conditions include failure of the top layer or layers of paint and generally require *limited* paint removal; and CLASS III conditions include substantial or multiple-layer failure and generally require *total* paint removal. It is precisely because conditions will vary at different points on the building that a careful inspection is critical. Each item of painted exterior woodwork (i.e., siding, doors, windows, eaves, shutters, and decorative elements) should be examined early in the planning phase and surface conditions noted.

CLASS I Exterior Surface Conditions Generally Requiring No Paint Removal

- Dirt, Soot, Pollution, Cobwebs, Insect Cocoons, etc.

Cause of Condition

Environmental "grime" or organic matter that tends to cling to painted exterior surfaces and, in particular, protected surfaces such as eaves, do not constitute a paint problem unless painted over rather than removed prior to repainting. If not removed, the surface deposits can be a barrier to proper adhesion and cause peeling.

Recommended Treatment

Most surface matter can be loosened by a strong, direct stream of water from the nozzle of a garden hose. Stubborn dirt and soot will need to be scrubbed off using ½ cup of household detergent in a gallon of water with a medium soft bristle brush. The cleaned surface should then be rinsed thoroughly, and permitted to dry before further inspection to determine if repainting is necessary. Quite often, cleaning provides a satisfactory enough result to postpone repainting.

⁵ See the Reading List for paint research and documentation information. See also *The Secretary of the Interior's Standards for Historic Preservation Projects with Guidelines for Applying the Standards* for recommended approaches on paints and finishes within various types of project work treatments.

- Mildew

Cause of Condition

Mildew is caused by fungi feeding on nutrients contained in the paint film or on dirt adhering to any surface. Because moisture is the single most important factor in its growth, mildew tends to thrive in areas where dampness and lack of sunshine are problems such as window sills, under eaves, around gutters and downspouts, on the north side of buildings, or in shaded areas near shrubbery. It may sometimes be difficult to distinguish mildew from dirt, but there is a simple test to differentiate: if a drop of household bleach is placed on the suspected surface, mildew will immediately turn white whereas dirt will continue to look like dirt.

Recommended Treatment

Because mildew can only exist in shady, warm, moist areas, attention should be given to altering the environment that is conducive to fungal growth. The area in question may be shaded by trees which need to be pruned back to allow sunlight to strike the building; or may lack rain gutters or proper drainage at the base of the building. If the shady or moist conditions can be altered, the mildew is less likely to reappear. A recommend solution for removing mildew consists of one cup non-ammoniated detergent, one quart household bleach, and one gallon water. When the surface is scrubbed with this solution using a medium soft brush, the mildew should disappear; however, for particularly stubborn spots, an additional quart of bleach may be added. After the area is mildew-free, it should then be rinsed with a direct stream of water from the nozzle of a garden hose, and permitted to dry thoroughly. When repainting, specially formulated "mildew-resistant" primer and finish coats should be used.

- Excessive Chalking

Cause of Condition

Chalking—or powdering of the paint surface—is caused by the gradual disintegration of the resin in the paint film. (The amount of chalking is determined both by the formulation of the paint and the amount of ultraviolet light to which the paint is exposed.) In moderation, chalking is the ideal way for a paint to "age," because the chalk, when rinsed by rainwater, carries discoloration and dirt away with it and thus provides an ideal surface for repainting. In excess, however, it is not desirable because the chalk can wash down onto a surface of a different color beneath the painted area and cause streaking as well as rapid disintegration of the paint film itself. Also, if a paint contains too much pigment for the amount of binder (as the old white lead carbonate/oil paints often did), excessive chalking can result.

Recommended Treatment

The chalk should be cleaned off with a solution of ½ cup household detergent to one gallon water, using a medium soft bristle brush. After scrubbing to remove the chalk, the surface should be rinsed with a direct stream of water from the nozzle of a garden hose, allowed to dry thoroughly, (but not long enough for the chalking process to recur) and repainted, using a non-chalking paint.

- Staining

Cause of Condition

Staining of paint coatings usually results from excess

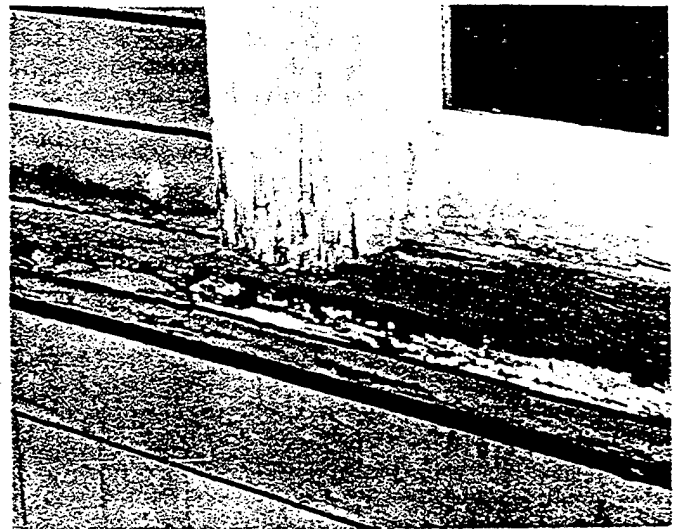

Fig. 4 Paint films wear unevenly depending on exposure and location. Exterior locations which are susceptible to accelerated deterioration are horizontal surfaces such as window sills. These and similar areas will require repainting more often than less vulnerable surfaces. In the case of this window sill where paint has peeled off and adjacent areas have cracked and alligatored, the paint should be totally removed. Prior to repainting, any weathered wood should be rejuvenated using a solution of 3 cups exterior varnish, 1 oz. paraffin wax, and mineral spirits/paint thinner/or turpentine to make 1 gallon. Liberal brush application should be made. This formula was tested over a 20-year period by the U.S. Department of Agriculture's Forest Products Laboratory and proved to be just as effective as water-repellent preservatives containing pentachlorophenol. After the surface has thoroughly dried (2-3 days of warm weather), the treated surface can be painted. A high quality oil-base primer followed by two top coats of a semi-gloss oil-enamel or latex-enamel paint is recommended. Photo: Baird M. Smith, AIA.

moisture reacting with materials within the wood substrate. There are two common types of staining, neither of which requires paint removal. The most prevalent type of stain is due to the oxidation or rusting of iron nails or metal (iron, steel, or copper) anchorage devices. A second type of stain is caused by a chemical reaction between moisture and natural extractives in certain woods (red cedar or redwood) which results in a surface deposit of colored matter. This is most apt to occur in new replacement wood within the first 10-15 years.

Recommended Treatment

In both cases, the source of the stain should first be located and the moisture problem corrected.

When stains are caused by rusting of the heads of nails used to attach shingles or siding to an exterior wall or by rusting or oxidizing iron, steel, or copper anchorage devices adjacent to a painted surface, the metal objects themselves should be hand sanded and coated with a rust-inhibitive primer followed by two finish coats. (Exposed nail heads should ideally be countersunk, spot primed, and the holes filled with a high quality wood filler except where exposure of the nail head was part of the original construction system or the wood is too fragile to withstand the countersinking procedure.)

Discoloration due to color extractives in replacement wood can usually be cleaned with a solution of equal parts denatured alcohol and water. After the affected area

has been rinsed and permitted to dry, a "stain-blocking primer" especially developed for preventing this type of stain should be applied (two primer coats are recommended for severe cases of bleeding prior to the finish coat). Each primer coat should be allowed to dry at least 48 hours.

CLASS II Exterior Surface Conditions Generally Requiring Limited Paint Removal

• **Crazing**

Cause of Condition

Crazing—fine, jagged interconnected breaks in the top layer of paint—results when paint that is several layers thick becomes excessively hard and brittle with age and is consequently no longer able to expand and contract with the wood in response to changes in temperature and humidity (see figure 5). As the wood swells, the bond between paint layers is broken and hairline cracks appear. Although somewhat more difficult to detect as opposed to other more obvious paint problems, it is well worth the time to scrutinize all surfaces for crazing. If not corrected, exterior moisture will enter the crazed surface, resulting in further swelling of the wood and, eventually, deep cracking and alligatoring, a Class III condition which requires total paint removal.

Recommended Treatment

Crazing can be treated by hand or mechanically sanding the surface, then repainting. Although the hairline cracks may tend to show through the new paint, the surface will be protected against exterior moisture penetration.

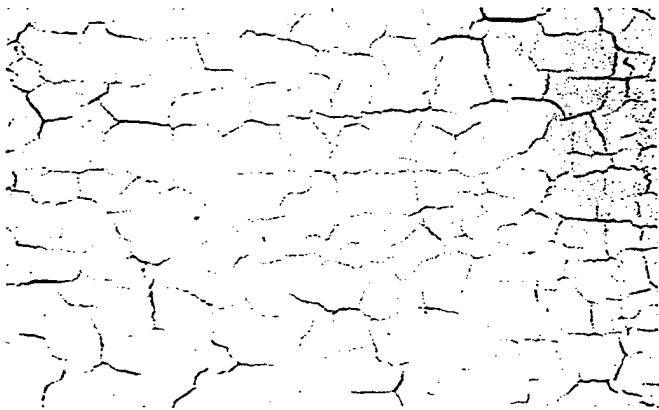

Fig. 5 Crazing—or surface cracking—is an exterior surface condition which can be successfully treated by sanding and painting. Photo: Courtesy, National Decorating Products Association.

• **Intercoat Peeling**

Cause of Condition

Intercoat peeling can be the result of improper surface preparation prior to the last repainting. This most often occurs in protected areas such as eaves and covered porches because these surfaces do not receive a regular rinsing from rainfall, and salts from air-borne pollutants thus accumulate on the surface. If not cleaned off, the new paint coat will not adhere properly and that layer will peel.

Another common cause of intercoat peeling is incompatibility between paint types (see figure 6). For example, if oil paint is applied over latex paint, peeling of the top

coat can sometimes result since, upon aging, the oil paint becomes harder and less elastic than the latex paint. If latex paint is applied over old, chalking oil paint, peeling can also occur because the latex paint is unable to penetrate the chalky surface and adhere.

Recommended Treatment

First, where salts or impurities have caused the peeling, the affected area should be washed down thoroughly after scraping, then wiped dry. Finally, the surface should be hand or mechanically sanded, then repainted.

Where peeling was the result of using incompatible paints, the peeling top coat should be scraped and hand or mechanically sanded. Application of a high quality oil type exterior primer will provide a surface over which either an oil or a latex topcoat can be successfully used.

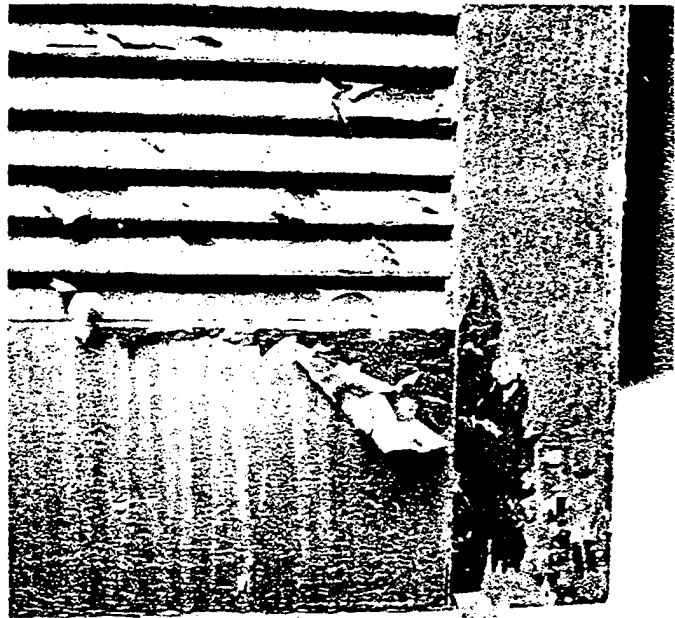

Fig. 6 This is an example of intercoat peeling. A latex top coat was applied directly over old oil paint and, as a result, the latex paint was unable to adhere. If latex is being used over oil, an oil-base primer should be applied first. Although much of the peeling latex paint can be scraped off, in this case, the best solution may be to chemically dip strip the entire shutter to remove all of the paint down to bare wood, rinse thoroughly, then repaint. Photo: Mary L. Oehrlein, AIA.

• **Solvent Blistering**

Cause of Condition

Solvent blistering, the result of a less common application error, is not caused by moisture, but by the action of ambient heat on paint solvent or thinners in the paint film. If solvent-rich paint is applied in direct sunlight, the top surface can dry too quickly and, as a result, solvents become trapped beneath the dried paint film. When the solvent vaporizes, it forces its way through the paint film, resulting in surface blisters. This problem occurs more often with dark colored paints because darker colors absorb more heat than lighter ones. To distinguish between solvent blistering and blistering caused by moisture, a blister should be cut open. If another layer of paint is visible, then solvent blistering is likely the problem whereas if bare wood is revealed, moisture is probably to blame. Solvent blisters are generally small.

Recommended Treatment

Solvent-blistered areas can be scraped, hand or mechanically sanded to the next sound layer, then repainted. In order to prevent blistering of painted surfaces, paint should not be applied in direct sunlight.

- **Wrinkling**

Cause of Condition

Another error in application that can easily be avoided is wrinkling (see figure 7). This occurs when the top layer of paint dries before the layer underneath. The top layer of paint actually moves as the paint underneath (a primer, for example) is drying. Specific causes of wrinkling include: (1) applying paint too thick; (2) applying a second coat before the first one dries; (3) inadequate brushing out; and (4) painting in temperatures higher than recommended by the manufacturer.

Recommended Treatment

The wrinkled layer can be removed by scraping followed by hand or mechanical sanding to provide as even a surface as possible, then repainted following manufacturer's application instructions.

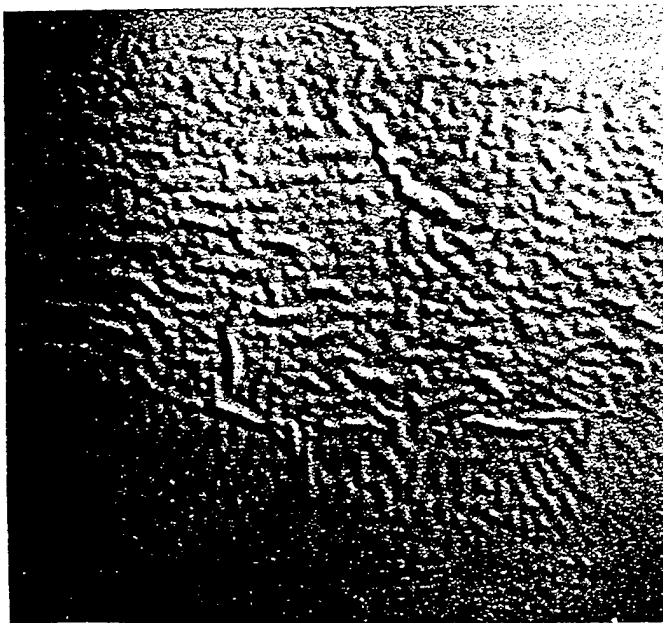

Fig. 7 Wrinkled layers can generally be removed by scraping and sanding as opposed to total paint removal. Following manufacturers' application instructions is the best way to avoid this surface condition. Photo: Courtesy, National Decorating Products Association.

CLASS III Exterior Surface Conditions Generally Requiring Total Paint Removal

If surface conditions are such that the majority of paint will have to be removed prior to repainting, it is suggested that a small sample of intact paint be left in an inconspicuous area either by covering the area with a metal plate, or by marking the area and identifying it in some way. (When repainting does take place, the sample should not be painted over). This will enable future investigators to have a record of the building's paint history.

- **Peeling**

Cause of Condition

Peeling to bare wood is most often caused by excess interior or exterior moisture that collects behind the paint

film, thus impairing adhesion (see figure 8). Generally beginning as blisters, cracking and peeling occur as moisture causes the wood to swell, breaking the adhesion of the bottom layer.

Recommended Treatment

There is no sense in repainting before dealing with the moisture problems because new paint will simply fail. Therefore, the first step in treating peeling is to locate and remove the source or sources of the moisture, not only because moisture will jeopardize the protective coating of paint but because, if left unattended, it can ultimately cause permanent damage to the wood. Excess interior moisture should be removed from the building through installation of exhaust fans and vents. Exterior moisture should be eliminated by correcting the following conditions prior to repainting: faulty flashing; leaking gutters; defective roof shingles; cracks and holes in siding and trim; deteriorated caulking in joints and seams; and shrubbery growing too close to painted wood. After the moisture problems have been solved, the wood must be permitted to dry out thoroughly. The damaged paint can then be scraped off with a putty knife, hand or mechanically sanded, primed, and repainted.

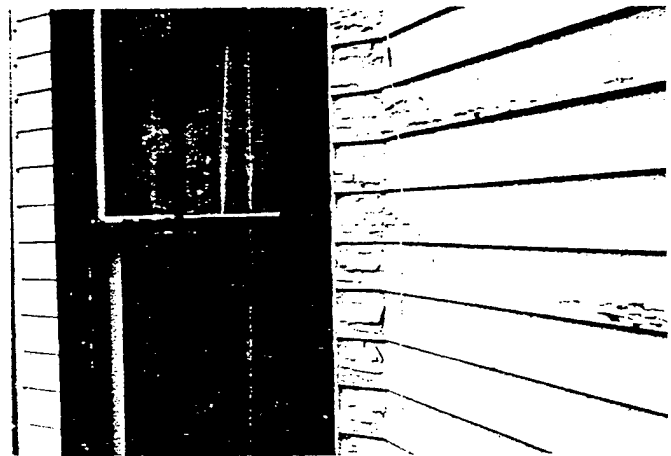

Fig. 8 Peeling to bare wood—one of the most common types of paint failure—is usually caused by an interior or exterior moisture problem. Photo: Anne E. Grimmer.

- **Cracking/ Alligatoring**

Cause of Condition

Cracking and alligatoring are advanced stages of crazing (see figure 9). Once the bond between layers has been broken due to intercoat paint failure, exterior moisture is able to penetrate the surface cracks, causing the wood to swell and deeper cracking to take place. This process continues until cracking, which forms parallel to grain, extends to bare wood. Ultimately, the cracking becomes an overall pattern of horizontal and vertical breaks in the paint layers that looks like reptile skin; hence, "alligatoring." In advanced stages of cracking and alligatoring, the surfaces will also flake badly.

Recommended Treatment

If cracking and alligatoring are present only in the top layers they can probably be scraped, hand or mechanically sanded to the next sound layer, then repainted. However, if cracking and/or alligatoring have progressed to

bare wood and the paint has begun to flake, it will need to be totally removed. Methods include scraping or paint removal with the electric heat plate, electric heat gun, or chemical strippers, depending on the particular area involved. Bare wood should be primed within 48 hours, then repainted.

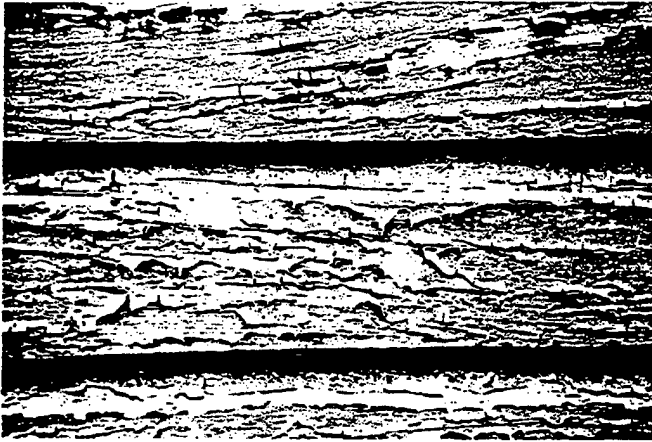

Fig. 9 Cracking, alligating, and flaking are evidence of long-term neglect of painted surfaces. The remaining paint on the clapboard shown here can be removed with an electric heat plate and wide-bladed scraper. In addition, unsound wood should be replaced and moisture problems corrected before primer and top coats of paint are applied. Photo: David W. Look, AIA.

Selecting the Appropriate/Safest Method to Remove Paint

After having presented the "hierarchy" of exterior paint surface conditions—from a mild condition such as mildew which simply requires cleaning prior to repainting to serious conditions such as peeling and alligating which require total paint removal—one important thought bears repeating: if a paint problem has been identified that warrants either limited or total paint removal, the gentlest method possible for the particular wooden element of the historic building should be selected from the many available methods.

The treatments recommended—based upon field testing as well as onsite monitoring of Department of Interior grant-in-aid and certification of rehabilitation projects—are therefore those which take three over-riding issues into consideration (1) the continued protection and preservation of the historic exterior woodwork; (2) the retention of the sequence of historic paint layers; and (3) the health and safety of those individuals performing the paint removal. By applying these criteria, it will be seen that no paint removal method is without its drawbacks and all recommendations are qualified in varying degrees.

Methods for Removing Paint

After a particular exterior paint surface condition has been identified, the next step in planning for repainting—if paint removal is required—is selecting an appropriate method for such removal.

The method or methods selected should be suitable for the specific paint problem as well as the particular wooden element of the building. Methods for paint removal can be divided into three categories (frequently, however, a combination of the three methods is used).

Each method is defined below, then discussed further and specific recommendations made:

Abrasive—"Abrading" the painted surface by manual and/or mechanical means such as scraping and sanding. Generally used for surface preparation and limited paint removal.

Thermal—Softening and raising the paint layers by applying heat followed by scraping and sanding. Generally used for total paint removal.

Chemical—Softening of the paint layers with chemical strippers followed by scraping and sanding. Generally used for total paint removal.

• Abrasive Methods (Manual)

If conditions have been identified that require limited paint removal such as crazing, intercoat peeling, solvent blistering, and wrinkling, scraping and hand sanding should be the first methods employed before using mechanical means. Even in the case of more serious conditions such as peeling—where the damaged paint is weak and already sufficiently loosened from the wood surface—scraping and hand sanding may be all that is needed prior to repainting.

Recommended Abrasive Methods (Manual)

Putty Knife/Paint Scraper: Scraping is usually accomplished with either a putty knife or a paint scraper, or both. Putty knives range in width from one to six inches and have a beveled edge. A putty knife is used in a pushing motion going under the paint and working from an area of loose paint toward the edge where the paint is still firmly adhered and, in effect, "beveling" the remaining layers so that as smooth a transition as possible is made between damaged and undamaged areas (see figure 10).

Paint scrapers are commonly available in 1½, 2½, and 3½ inch widths and have replaceable blades. In addition, profiled scrapers can be made specifically for use on moldings. As opposed to the putty knife, the paint scraper is used in a pulling motion and works by raking the damaged areas of paint away.

The obvious goal in using the putty knife or the paint scraper is to selectively remove the affected layer or layers of paint; however, both of these tools, particularly the paint scraper with its hooked edge, must be used with care to properly prepare the surface and to avoid gouging the wood.

Sandpaper/Sanding Block/Sanding sponge: After manually removing the damaged layer or layers by scraping, the uneven surface (due to the almost inevitable removal of varying numbers of paint layers in a given area) will need to be smoothed or "feathered out" prior to repainting. As stated before, hand sanding, as opposed to harsher mechanical sanding, is recommended if the area is relatively limited. A coarse grit, open-coat flint sandpaper—the least expensive kind—is useful for this purpose because, as the sandpaper clogs with paint it must be discarded and this process repeated until all layers adhere uniformly.

Blocks made of wood or hard rubber and covered with sandpaper are useful for handsanding flat surfaces. Sanding sponges—rectangular sponges with an abrasive aggregate on their surfaces—are also available for detail work that requires reaching into grooves because the sponge easily conforms to curves and irregular surfaces. All sanding should be done with the grain.

Summary of Abrasive Methods (Manual)

Recommended: Putty knife, paint scraper, sandpaper, sanding block, sanding sponge.

Applicable areas of building: All areas.

For use on: Class I, Class II, and Class III conditions.

Health/Safety factors: Take precautions against lead dust, eye damage; dispose of lead paint residue properly.



Fig. 10 An excellent example of inadequate scraping before repainting, the problems here are far more than cosmetic. This improperly prepared surface will permit moisture to get behind the paint film which, in turn, will result in chipping and peeling. Photo: Baird M. Smith, AIA.

• Abrasive Methods (Mechanical)

If hand sanding for purposes of surface preparation has not been productive or if the affected area is too large to consider hand sanding by itself, mechanical abrasive methods, i.e., power-operated tools may need to be employed; however, it should be noted that the majority of tools available for paint removal can cause damage to fragile wood and must be used with great care.

Recommended Abrasive Methods (Mechanical)

Orbital sander: Designed as a finishing or smoothing tool—not for the removal of multiple layers of paint—the orbital sander is thus recommended when limited paint removal is required prior to repainting. Because it sands in a small diameter circular motion (some models can also be switched to a back-and-forth vibrating action), this tool is particularly effective for “feathering” areas where paint has first been scraped (see figure 11). The abrasive surface varies from about 3×7 inches to 4×9 inches and sandpaper is attached either by clamps or sliding clips. A medium grit, open-coat aluminum oxide sandpaper should be used; fine sandpaper clogs up so quickly that it is ineffective for smoothing paint.

Belt sander: A second type of power tool—the belt sander—can also be used for removing limited layers of paint but,

in this case, the abrasive surface is a continuous belt of sandpaper that travels at high speeds and consequently offers much less control than the orbital sander. Because of the potential for more damage to the paint or the wood, use of the belt sander (also with a medium grit sandpaper) should be limited to flat surfaces and only skilled operators should be permitted to operate it within a historic preservation project.

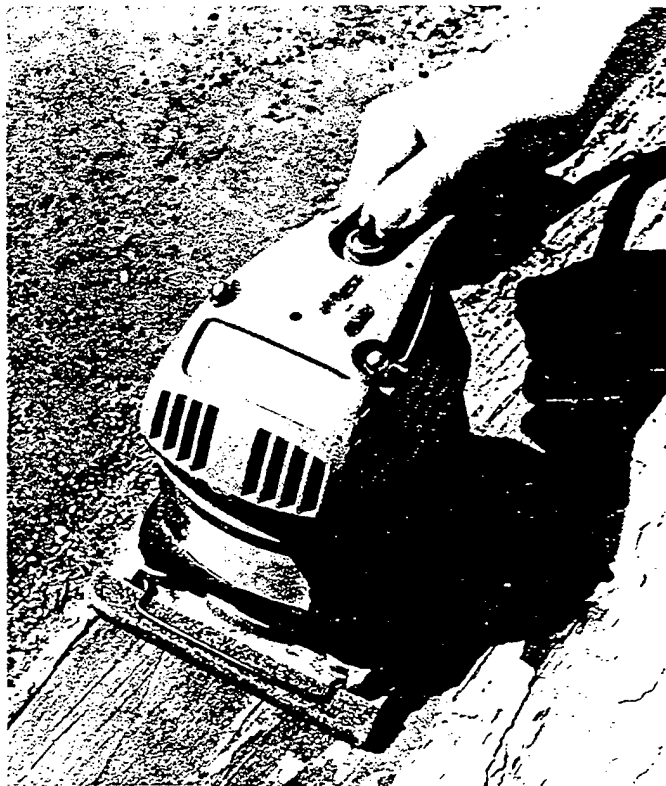

Fig. 11 The orbital sander can be used for limited paint removal, i.e., for smoothing flat surfaces after the majority of deteriorated paint has already been scraped off. Photo: Charles E. Fisher, III.

Not Recommended

Rotary Drill Attachments: Rotary drill attachments such as the rotary sanding disc and the rotary wire stripper should be avoided. The disc sander—usually a disc of sandpaper about 5 inches in diameter secured to a rubber based attachment which is in turn connected to an electric drill or other motorized housing—can easily leave visible circular depressions in the wood which are difficult to hide, even with repainting. The rotary wire stripper—clusters of metals wires similarly attached to an electric drill-type unit—can actually shred a wooden surface and is thus to be used exclusively for removing corrosion and paint from metals.

Waterblasting: Waterblasting above 600 p.s.i. to remove paint is not recommended because it can force water into the woodwork rather than cleaning loose paint and grime from the surface; at worst, high pressure waterblasting causes the water to penetrate exterior sheathing and damages interior finishes. A detergent solution, a medium soft bristle brush, and a garden hose for purposes of rinsing, is the gentlest method involving water and is recommended when cleaning exterior surfaces prior to repainting.

Sandblasting: Finally—and undoubtedly most vehemently “not recommended”—sandblasting painted exterior woodwork will indeed remove paint, but at the same time can scar wooden elements beyond recognition. As with rotary wire strippers, sandblasting erodes the soft porous fibers (spring wood) faster than the hard, dense fibers (summer wood), leaving a pitted surface with ridges and valleys. Sandblasting will also erode projecting areas of carvings and moldings before it removes paint from concave areas (see figure 12). Hence, this abrasive method is potentially the most damaging of all possibilities, even if a contractor promises that blast pressure can be controlled so that the paint is removed without harming the historic exterior woodwork. (For Additional Information, See Preservation Briefs 6, “Dangers of Abrasive Cleaning to Historic Buildings”.)

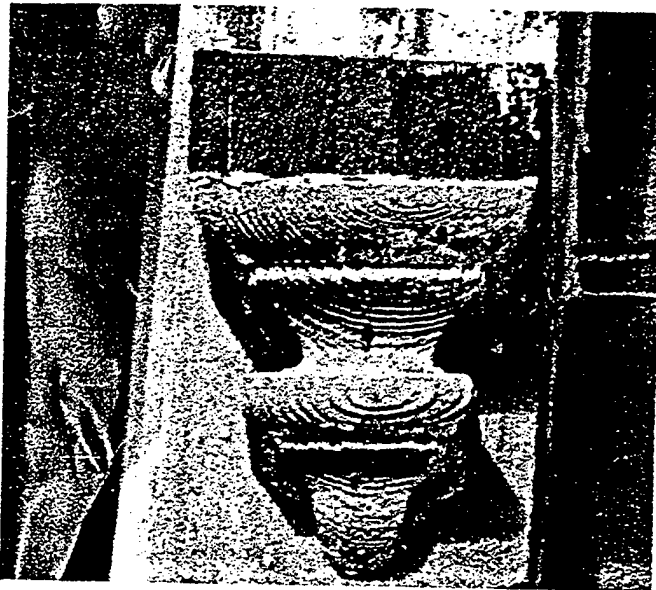

Fig. 12 Sandblasting has permanently damaged this ornamental bracket. Even paint will not be able to hide the deep erosion of the wood. Photo: David W. Look, AIA.

Summary of Abrasive Methods (Mechanical)

Recommended: Orbital sander, belt sander (skilled operator only).

Applicable areas of building: Flat surfaces, i.e., siding, eaves, doors, window sills.

For use on: Class II and Class III conditions.

Health/Safety factors: Take precautions against lead dust and eye damage; dispose of lead paint residue properly.

Not Recommended: Rotary drill attachments, high pressure waterblasting, sandblasting.

• Thermal Methods

Where exterior surface conditions have been identified that warrant total paint removal such as peeling, cracking, or alligatoring, two thermal devices—the electric heat plate and the electric heat gun—have proven to be quite successful for use on different wooden elements of the historic building. One thermal method—the blow torch—is not recommended because it can scorch the wood or even burn the building down!

Recommended Thermal Methods

Electric heat plate: The electric heat plate (see figure 13) operates between 500 and 800 degrees Fahrenheit (not hot enough to vaporize lead paint), using about 15 amps of power. The plate is held close to the painted exterior surface until the layers of paint begin to soften and blister, then moved to an adjacent location on the wood while the softened paint is scraped off with a putty knife (it should be noted that the heat plate is most successful when the paint is very thick!). With practice, the operator can successfully move the heat plate evenly across a flat surface such as wooden siding or a window sill or door in a continuous motion, thus lessening the risk of scorching the wood in an attempt to reheat the edge of the paint sufficiently for effective removal. Since the electric heat plate's coil is “red hot,” extreme caution should be taken to avoid igniting clothing or burning the skin. If an extension cord is used, it should be a heavy-duty cord (with 3-prong grounded plugs). A heat plate could overload a circuit or, even worse, cause an electrical fire; therefore, it is recommended that this implement be used with a single circuit and that a fire extinguisher always be kept close at hand.



Fig. 13 The electric heat plate (with paint scraper) is particularly useful for removing paint down to bare wood on flat surfaces such as doors, window frames, and siding. After scraping, some light sanding will probably be necessary to smooth the surface prior to application of primer and top coats. Photo: David W. Look, AIA.

Electric heat gun: The electric heat gun (electric hot-air gun) looks like a hand-held hairdryer with a heavy-duty metal case (see figure 14). It has an electrical resistance coil that typically heats between 500 and 750 degrees Fahrenheit and, again, uses about 15 amps of power which requires a heavy-duty extension cord. There are some heat guns that operate at higher temperatures but they should not be purchased for removing old paint

because of the danger of lead paint vapors. The temperature is controlled by a vent on the side of the heat gun. When the vent is closed, the heat increases. A fan forces a stream of hot air against the painted woodwork, causing a blister to form. At that point, the softened paint can be peeled back with a putty knife. It can be used to best advantage when a paneled door was originally varnished, then painted a number of times. In this case, the paint will come off quite easily, often leaving an almost pristine varnished surface behind. Like the heat plate, the heat gun works best on a heavy paint build-up. (It is, however, not very successful on only one or two layers of paint or on surfaces that have only been varnished. The varnish simply becomes sticky and the wood scorches.)

Although the heat gun is heavier and more tiring to use than the heat plate, it is particularly effective for removing paint from detail work because the nozzle can be directed at curved and intricate surfaces. Its use is thus more limited than the heat plate, and most successfully used in conjunction *with* the heat plate. For example, it takes about two to three hours to strip a paneled door with a heat gun, but if used in combination with a heat plate for the large, flat area, the time can usually be cut in half. Although a heat gun seldom scorches wood, it can cause fires (like the blow torch) if aimed at the dusty cavity between the exterior sheathing and siding and interior lath and plaster. A fire may smolder for hours before flames break through to the surface. Therefore, this thermal device is best suited for use on solid decorative elements, such as molding, balusters, fretwork, or "gingerbread."



Fig. 14 The nozzle on the electric heat gun permits hot air to be aimed into cavities on solid decorative elements such as this applied column. After the paint has been sufficiently softened, it can be removed with a profiled scraper. Photo: Charles E. Fisher, III.

Not Recommended

Blow Torch: Blow torches, such as hand-held propane or butane torches, were widely used in the past for paint removal because other thermal devices were not available. With this technique, the flame is directed toward the paint until it begins to bubble and loosen from the surface. Then the paint is scraped off with a putty knife. Although this is a relatively fast process, at temperatures between 3200 and 3800 degrees Fahrenheit the open flame is not only capable of burning a careless operator and causing severe damage to eyes or skin, it can easily scorch or ignite the wood. The other fire hazard is more insidious. Most frame buildings have an air space between the exterior sheathing and siding and interior lath and plaster. This cavity usually has an accumulation of dust which is also easily ignited by the open flame of a blow torch. Finally, lead-base paints will vaporize at high temperatures, releasing toxic fumes that can be unknowingly inhaled. Therefore, because both the heat plate and the heat gun are generally safer to use—that is, the risks are much more controllable—the blow torch should definitely be avoided!

Summary of Thermal Methods

Recommended: Electric heat plate, electric heat gun.

Applicable areas of building: Electric heat plate—flat surfaces such as siding, eaves, sash, sills, doors. Electric heat gun—solid decorative molding, balusters, fretwork, or "gingerbread."

For use on: Class III conditions.

Health/Safety factors: Take precautions against eye damage and fire. Dispose of lead paint residue properly.

Not Recommended: Blow torch.

• Chemical Methods

With the availability of effective thermal methods for total paint removal, the need for chemical methods—in the context of preparing historic exterior woodwork for repainting—becomes quite limited. Solvent-base or caustic strippers may, however, play a supplemental role in a number of situations, including:

- Removing paint residue from intricate decorative features, or in cracks or hard to reach areas if a heat gun has not been completely effective;
- Removing paint on window muntins because heat devices can easily break the glass;
- Removing varnish on exterior doors after all layers of paint have been removed by a heat plate/heat gun if the original varnish finish is being restored;
- Removing paint from detachable wooden elements such as exterior shutters, balusters, columns, and doors by dip-stripping when other methods are too laborious.

Recommended Chemical Methods (Use With Extreme Caution)

Because all chemical paint removers can involve potential health and safety hazards, no wholehearted recommendations can be made from that standpoint. Commonly known as "paint removers" or "strippers," both solvent-base or caustic products are commercially available that, when poured, brushed, or sprayed on painted exterior woodwork are capable of softening several layers of paint at a time so that the resulting "sludge"—which should be remembered is nothing less than the sequence of historic

paint layers—can be removed with a putty knife. Detachable wood elements such as exterior shutters can also be “dip-stripped.”

Solvent-base Strippers: The formulas tend to vary, but generally consist of combinations of organic solvents such as methylene chloride, isopropanol, toluol, xylol, and methanol; thickeners such as methyl cellulose; and various additives such as paraffin wax used to prevent the volatile solvents from evaporating before they have time to soak through multiple layers of paint. Thus, while some solvent-base strippers are quite thin and therefore unsuitable for use on vertical surfaces, others, called “semi-paste” strippers, are formulated for use on vertical surfaces or the underside of horizontal surfaces.

However, whether liquid or semi-paste, there are two important points to stress when using any solvent-base stripper: First, the vapors from the organic chemicals can be highly toxic if inhaled; skin contact is equally dangerous because the solvents can be absorbed; second, many solvent-base strippers are flammable. Even though application out-of-doors may somewhat mitigate health and safety hazards, a respirator with special filters for organic solvents is recommended and, of course, solvent-base strippers should never be used around open flames, lighted cigarettes, or with steel wool around electrical outlets.

Although appearing to be the simplest for exterior use, a particular type of solvent-base stripper needs to be mentioned here because it can actually cause the most problems. Known as “water-rinsable,” such products have a high proportion of methylene chloride together with emulsifiers. Although the dissolved paint can be rinsed off with water with a minimum of scraping, this ultimately creates more of a problem in cleaning up and properly disposing of the sludge. In addition, these strippers can leave a gummy residue on the wood that requires removal with solvents. Finally, water-rinsable strippers tend to raise the grain of the wood more than regular strippers.

On balance, then, the regular strippers would seem to work just as well for exterior purposes and are perhaps even better from the standpoint of proper lead sludge disposal because they must be hand scraped as opposed to rinsed off (a coffee-can with a wire stretched across the top is one effective way to collect the sludge; when the putty knife is run across the wire, the sludge simply falls into the can. Then, when the can is filled, the wire is removed, the can capped, and the lead paint sludge disposed of according to local health regulations).

Caustic Strippers: Until the advent of solvent-base strippers, caustic strippers were used exclusively when a chemical method was deemed appropriate for total paint removal prior to repainting or refinishing. Now, it is more difficult to find commercially prepared caustic solutions in hardware and paint stores for home-owner use with the exception of lye (caustic soda) because solvent-base strippers packaged in small quantities tend to dominate the market.

Most commercial dip stripping companies, however, continue to use variations of the caustic bath process because it is still the cheapest method available for removing paint. Generally, dip stripping should be left to professional companies because caustic solutions can dissolve skin and permanently damage eyes as well as present serious disposal problems in large quantities.

If exterior shutters or other detachable elements are be-

ing sent out⁴ for stripping in a caustic solution, it is wise to see samples of the company's finished work. While some companies do a first-rate job, others can leave a residue of paint in carvings and grooves. Wooden elements may also be soaked too long so that the wood grain is raised and roughened, requiring extensive hand sanding later. In addition, assurances should be given by these companies that caustic paint removers will be neutralized with a mild acid solution or at least thoroughly rinsed with water after dipping (a caustic residue makes the wood feel slippery). If this is not done, the lye residue will cause new paint to fail.

Summary of Chemical Methods

Recommended, with extreme caution: Solvent-base strippers, caustic strippers.

Applicable areas of buildings: decorative features, window muntins, doors, exterior shutters, columns, balusters, and railings.

For use on: Class III Conditions.

Health/Safety factors: Take precautions against inhaling toxic vapors; fire; eye damage; and chemical poisoning from skin contact. Dispose of lead residue properly

General Paint Type Recommendations

Based on the assumption that the exterior wood has been painted with oil paint many times in the past and the existing top coat is therefore also an oil paint,⁵ it is recommended that for CLASS I and CLASS II paint surface conditions, a top coat of high quality oil paint be applied when repainting. The reason for recommending oil rather than latex paints is that a coat of latex paint applied directly over old oil paint is more apt to fail. The considerations are twofold. First, because oil paints continue to harden with age, the old surface is sensitive to the added stress of shrinkage which occurs as a new coat of paint dries. Oil paints shrink less upon drying than latex paints and thus do not have as great a tendency to pull the old paint loose. Second, when exterior oil paints age, the binder releases pigment particles, causing a chalky surface. Although for best results, the chalk (or dirt, etc.) should *always* be cleaned off prior to repainting, a coat of new oil paint is more able to penetrate a chalky residue and adhere than is latex paint. Therefore, unless it is possible to thoroughly clean a heavy chalked surface, oil paints—on balance—give better adhesion.

If however, a latex top coat is going to be applied over several layers of old oil paint, an oil primer should be applied first (the oil primer creates a flat, porous surface to which the latex can adhere). After the primer has thoroughly dried, a latex top coat may be applied. In the long run, changing paint types is more time consuming and expensive. An application of a new oil-type top coat on the old oil paint is, thus, the preferred course of action.

⁴ Marking the original location of the shutter by number (either by stamping numbers into the end grain with metal numeral dies or cutting numbers into the end with a pen knife) will minimize difficulties when rehangng them.

⁵ If the top coat is latex paint (when viewed by the naked eye or, preferably, with a magnifying glass, it looks like a series of tiny craters) it may either be repainted with new latex paint or with oil paint. Normal surface preparation should precede any repainting.

If CLASS III conditions have necessitated total paint removal, there are two options, both of which assure protection of the exterior wood: (1) an oil primer may be applied followed by an oil-type top coat, preferably by the same manufacturer; or (2) an oil primer may be applied followed by a latex top coat, again using the same brand of paint. It should also be noted that primers were never intended to withstand the effects of weathering; therefore, the top coat should be applied as soon as possible after the primer has dried.

Conclusion

The recommendations outlined in this Brief are cautious because at present there is no completely safe and effective method of removing old paint from exterior woodwork. This has necessarily eliminated descriptions of several methods still in a developmental or experimental stage, which can therefore neither be recommended nor precluded from future recommendation. With the ever-increasing number of buildings being rehabilitated, however, paint removal technology should be stimulated and, in consequence, existing methods refined and new methods developed which will respect both the historic wood and the health and safety of the operator.

Special thanks go to Baird M. Smith, AIA (formerly Chief, Preservation Technology Branch, TPS) for providing general direction in the development of the manuscript. In addition, the following individuals are to be thanked for their contributions as technical experts in the field: Royal T. Brown, National Paint and Coatings Association, Washington, D.C.; Dr. Judith E. Selwyn, Preservation Technology Associates, Boston, Massachusetts; and Dennis R. Vacca, Pratt & Lambert Co., Carlstadt, New Jersey. Finally, thanks go to several National Park Service staff members whose valuable comments were incorporated into the text and who contributed to the production of the brief: James A. Caufield, Anne E. Grimmer, Jean E. Travers, David G. Battle, Sharon C. Park, AIA, Charles E. Fisher III, Sara K. Blumenthal, and Martha A. Gutrick.

Reading List

- Batcheler, Penelope Hartshorne, "Paint Color Research and Restoration," *Technical Leaflet 15*. Nashville: American Association for State and Local History (undated).
- "Danger: Restoration May Be Hazardous to Your Health." *The Old House Journal*. Vol. 4, No. 5 (May 1976), pp. 9-11.
- Gola, Edward F. "Avoiding Mistakes in Exterior Painting." *The Old House Journal*. Vol. 4, No. 6 (June 1976), pp. 1, 4-5.
- "How to Assure a Satisfactory Paint Job." *Scientific Section: Circular 784*. Washington, DC: National Paint, Varnish and Lacquer Association (undated).
- Labine, Clem. "Selecting the Best Exterior Paint." *The Old House Journal*. Vol. 4, No. 7 (July 1976), pp. 1, 10-11.
- Morton, W. Brown III and Hume, Gary L. *The Secretary of the Interior's Standards for Historic Preservation Projects with Guidelines for Applying the Standards*. Washington, DC: Department of Interior, 1979.
- Paint Problem Solver*. St. Louis: National Decorating Products Association, 1980.
- "Special Issue: Exterior Painting." *The Old House Journal*. Vol. 4, No. 4 (April 1981), pp. 71-94.
- Thorsen, John W. "Hazardous Waste: What is it? How to Handle it." *Professional Decorating & Coating Action*. Vol. 43, No. 4 (September 1981), pp. 4-5.

This publication has been prepared pursuant to The Economic Recovery Tax Act of 1981, which directs the Secretary of the Interior to certify rehabilitations of historic buildings that are consistent with their historic character: the advice and guidance in this brief will assist property owners in complying with the requirements of this law.

Preservation Briefs 10 has been developed under the technical editorship of Lee H. Nelson, AIA, Chief, Preservation Assistance Division, National Park Service, U.S. Department of the Interior, Washington, D.C. 20240. Comments on the usefulness of this information are welcomed and can be sent to Mr. Nelson at the above address.

This publication is not copyrighted and can be reproduced without penalty. Normal procedures for credit to the authors and the National Park Service are appreciated.

September 1982

15 PRESERVATION BRIEFS

Preservation of Historic Concrete: Problems and General Approaches

William B. Coney, A.I.A.

U.S. Department of the Interior, National Park Service
Rocky Mountain Regional Office, Division of Cultural Resources

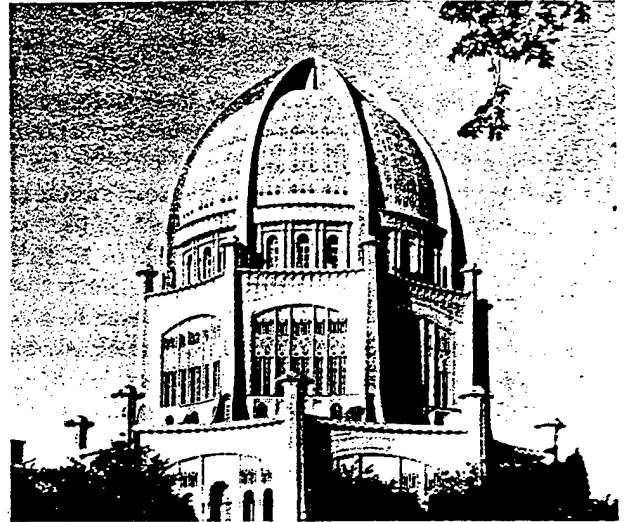

The Secretary of the Interior's "Standards for Rehabilitation" require that deteriorated architectural features shall be repaired rather than replaced. When the severity of deterioration requires removal of historic material, its replacement should match the material being replaced in composition, design, color, texture, and other visual qualities.

"Concrete" is a name applied to any of a number of compositions consisting of sand, gravel, crushed stone, or other coarse material, bound together with various kinds of cementitious materials, such as lime or cements. When water is added, the mix undergoes a chemical reaction and hardens. An extraordinarily versatile building material, concrete is used for the utilitarian, the ornamental, and the monumental. While early proponents of modern concrete considered it to be permanent, it is, like all materials, subject to deterioration. This Brief surveys the principal problems posed by concrete deterioration, their likely causes, and approaches to their remedies. In almost every instance, remedial work should only be undertaken by qualified professionals. Faulty concrete repair can worsen structural problems and lead to further damage or safety hazards. Concrete repairs are not the province of do-it-yourselfers. Consequently, the corrective measures discussed here are included for general information purposes only; they do not provide "how to" advice.

HISTORICAL OVERVIEW

The Romans found that the mixture of lime putty with pozzolana, a fine volcanic ash, would harden under water. The result was possibly the first hydraulic cement. It became a major feature of Roman building practice, and was used in many buildings and engineering projects such as bridges and aqueducts. Concrete technology was kept alive during the Middle Ages in Spain and Africa, with the Spanish introducing a form of concrete to the New World in the first decades of the 16th century. It was used by both the Spanish and English in coastal areas stretching from

Florida to South Carolina. Called "tapia," or "tabby," the substance was a creamy white, monolithic masonry material composed of lime, sand, and an aggregate of shells, gravel, or stone mixed with water. This mass of material was placed between wooden forms, tamped, and allowed to dry, the building arising in layers, about one foot at a time.

Despite its early use, concrete was slow in achieving widespread acceptance as a building material in the United States. In 1853, the second edition of Orson S. Fowler's *A Home for All* publicized the advantages of "gravel wall" construction to a wide audience, and poured gravel wall buildings appeared across the United States (see fig. 1). Seguin, Texas, 35 miles east



Fig. 1. Milton House, Milton, Wisconsin (1844). An early example of gravel wall construction with 12- to 15-inch thick monolithic concrete walls coated on the exterior with stucco. Photo: William B. Coney.

of San Antonio, came to be called "The Mother of Concrete Cities" for some 90 concrete buildings made from local "lime water" and gravel (see fig. 2). Impressed by the economic advantages of poured gravel wall or "lime-grout" construction, the Quartermaster General's Office of the War Department embarked on a campaign to improve the quality of building for frontier military posts. As a result, lime-grout structures were built at several western posts, such as the buildings that were constructed with 12- or 18-inch-thick walls at Fort Laramie, Wyoming between 1872 and 1885. By the 1880s sufficient experience had been gained with unreinforced concrete to permit construction of much larger buildings. The Ponce de Leon Hotel in St. Augustine, Florida, is a notable example from this period (see fig. 3).

Reinforced concrete in the United States dates from 1860, when S.T. Fowler obtained a patent for a reinforced concrete wall. In the early 1870s William E. Ward built his own house in Port Chester, New York, using concrete reinforced with iron rods for all structural elements. Despite these developments, such construction remained a novelty until after 1880, when in-



Fig. 2. Sebastopol House, Seguin, Texas (1856). This Greek Revival dwelling is one of the few remaining poured-in-place concrete structures in this Texas town noted for its construction of over 90 concrete buildings in the mid-nineteenth century. The high parapets surrounding the flat roof were lined and served as a water reservoir to cool the house. Photo: Texas Historical Commission.



Fig. 3. Ponce de Leon Hotel, St. Augustine, Florida (1885-87). An example of unreinforced concrete used on a grand scale, this Spanish Colonial Revival hotel was designed by Carrere and Hastings and commissioned by railroad magnate Henry Flagler. The building now serves as the main campus hall for Flagler College. Photo: Flagler College.

novations introduced by Ernest L. Ransome made reinforced concrete more practicable. The invention of the horizontal rotary kiln allowed production of a cheaper, more uniform and reliable cement, and led to the greatly increased acceptance of concrete after 1900.

During the early 20th century Ransome in Beverly, Massachusetts, Albert Kahn in Detroit, and Richard E. Schmidt in Chicago promoted concrete for utilitarian buildings with their "factory style," featuring an exposed concrete skeleton filled with expanses of glass. Thomas Edison's cast-in-place reinforced concrete homes in Union Township, New Jersey, proclaimed a similarly functional emphasis in residential construction (see fig. 4). From the 1920s onward, concrete began to be used with spectacular design results: in James J. Earley and Louis Bourgeois' exuberant, graceful Baha'i Temple in Wilmette, Illinois (see cover); and in Frank Lloyd Wright's masterpiece "Fallingwater" near Mill Run, Pennsylvania (see fig. 5). Eero Saarinen's soaring Terminal Building at Dulles International Airport outside Washington, D.C., exemplifies the masterful use of concrete achieved in the Modern era.

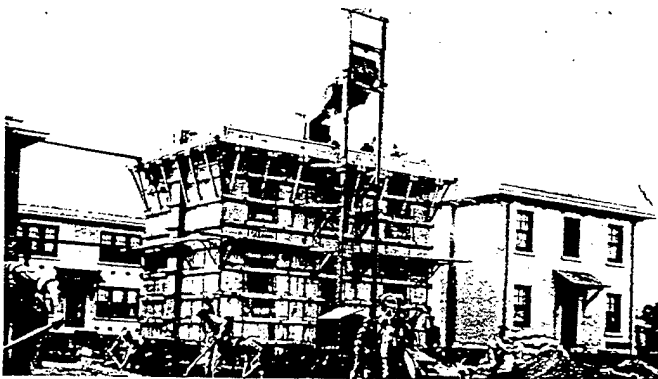

Fig. 4. Thomas A. Edison's Cast-in-Place Houses, Union Township, New Jersey (1909). This construction photo shows the formwork for the cast-in-place reinforced concrete houses built as low-cost housing using a standard 25- by 30-foot module. Photo: Edison National Historical Site.



Fig. 5. "Fallingwater," near Mill Run, Pennsylvania (1936-37). This dramatic reinforced concrete residence by Frank Lloyd Wright is anchored into bedrock on the hillside and cantilevered over the stream. The great tensile strength of reinforced concrete made this type of construction possible. Photo: Paul Mayen.

Types of Concrete

Unreinforced concrete is a composite material containing aggregates (sand, gravel, crushed shell, or rock) held together by a cement combined with water to form a paste, and gets its name from the fact that it does not have any iron or steel reinforcing bars. It was the earliest form of concrete. The ingredients become a plastic mass that hardens as the concrete hydrates, or "cures." Unreinforced concrete, however, is relatively weak, and since the turn of the century has largely been replaced by reinforced concrete. *Reinforced concrete* is concrete strengthened by the inclusion of metal bars, which increase the tensile strength of concrete. Both unreinforced and reinforced concrete can be either cast in place or precast. *Cast-in-place concrete* is poured on-site into a previously erected formwork that is removed after the concrete has set. *Precast concrete* is molded off-site into building components. More recent developments in concrete technology include *post-tensioned concrete* and *pre-stressed concrete*, which feature greater strength and reduced cracking in reinforced structural elements.

CAUSES OF CONCRETE DETERIORATION

Deterioration in concrete can be caused by environmental factors, inferior materials, poor workmanship, inherent structural design defects, and inadequate maintenance (see figs. 6, 7, and 8).

Environmental factors are a principal source of concrete deterioration. Concrete absorbs moisture readily, and this is particularly troublesome in regions of recurrent freeze-thaw cycles. Freezing water produces expansive pressure in the cement paste or in nondurable aggregates. Carbon dioxide, another atmospheric component, can cause the concrete to deteriorate by reacting with the cement paste at the surface.

Materials and workmanship in the construction of early concrete buildings are potential sources of problems. For example, aggregates used in early concrete, such as cinders from burned coal and certain crushed brick, absorb water and produce a weak and porous concrete. Alkali-aggregate reactions within the concrete can result in cracking and white surface staining. Ag-



Fig. 6. Battery Fortifications, Ft. Washington, Maryland (1891-97). This unreinforced concrete fortification exhibits several kinds of deterioration: the diagonal structural crack due to uneven settlement, the long horizontal crack at the cold joint, the spalling of the concrete surface coating, and vegetative growth. Photo: Sharon C. Park, AIA.

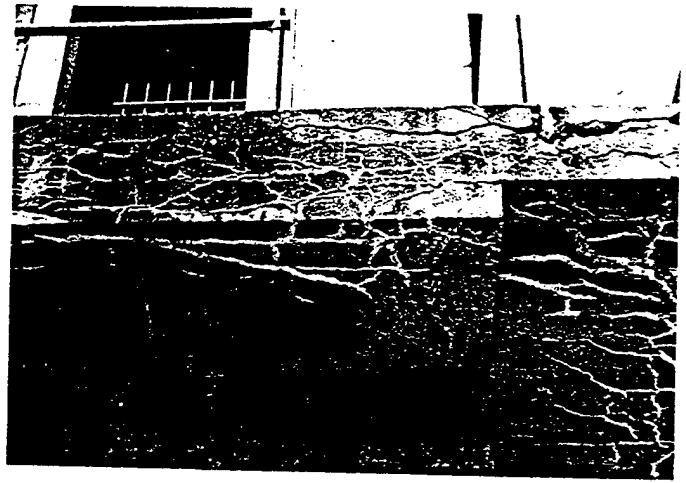

Fig. 7. Battery Commander's Station, Ft. Washington, Maryland (1904). This reinforced concrete tower with a cantilevered balcony is showing serious deterioration. Water has penetrated the slab, causing freeze-thaw spalling around the posts and corrosion of the reinforcing bars. This internal corrosion is causing expansion inside the slab and creating major horizontal cracks in the concrete. Under the balcony can be seen the network of hardened white calcified deposits, which have exuded through cracks in the concrete as a result of alkali-aggregate reaction. Photo: Lee H. Nelson, FAIA.

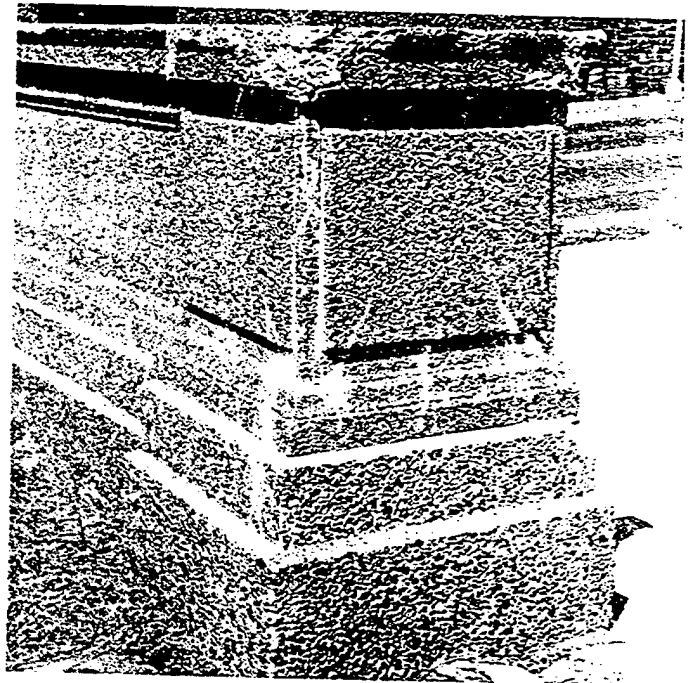

Fig. 8. Meridian Hill, Washington, D.C. (1934). This reinforced concrete pier has lost much of its projecting molding partly from accidental impact and partly from spalling induced by freeze-thaw action. Evidence of moisture leaching out from the interior through cracks is seen as white deposits on the surface of this exposed aggregate concrete. Photo: Lee H. Nelson, FAIA.

gregates were not always properly graded by size to ensure an even distribution of elements from small to large. The use of aggregates with similarly sized particles normally produced a poorly consolidated and therefore weaker concrete.

Early builders sometimes inadvertently compromised concrete by using seawater or beach sand in the mix or by using calcium chloride or a similar salt as an additive to make the concrete more "fireproof." A common practice, until recently, was to add salt to strengthen concrete or to lower the freezing point during cold-weather construction. These practices cause problems over the long term.

In addition, early concrete was not vibrated when poured into forms as it is today. More often it was tamped or rodded to consolidate it, and on floor slabs it was often rolled with increasingly heavier rollers filled with water. These practices tended to leave voids (areas of no concrete) at congested areas, such as at reinforcing bars at column heads and other critical structural locations. Areas of connecting voids seen when concrete forms are removed are known as "honeycombs" and can reduce the protective cover over the reinforcing bars.

Other problems caused by poor workmanship are not unknown today. If the first layer of concrete is allowed to harden before the next one is poured next to or on top of it, joints can form at the interface of the layers. In some cases, these "cold joints" visibly detract from the architecture, but are otherwise harmless. In other cases, "cold joints" can permit water to infiltrate, and subsequent free-thaw action can cause the joints to move. Dirt packed in the joints allows weeds to grow, further opening paths for water to enter. Inadequate curing can also lead to problems. If moisture leaves newly poured concrete too rapidly because of low humidity, excessive exposure to sun or wind, or use of too porous a substrate, the concrete will develop shrinkage cracks and will not reach its full potential strength.

Structural Design Defects in historic concrete structures can be an important cause of deterioration. For example, the amount of protective concrete cover around reinforcing bars was often insufficient. Another design problem in early concrete buildings is related to the absence of standards for expansion-contraction joints to prevent stresses caused by thermal movements, which may result in cracking.

Improper Maintenance of historic buildings can cause long-term deterioration of concrete. Water is a principal source of damage to historic concrete (as to almost every other material) and prolonged exposure to it can cause serious problems. Unrepaired roof and plumbing leaks, leaks through exterior cladding, and unchecked absorption of water from damp earth are potential sources of building problems. Deferred repair of cracks allowing water penetration and freeze-thaw attacks can even cause a structure to collapse. In some cases the application of waterproof surface coatings can aggravate moisture-related problems by trapping water vapor within the underlying material.

MAJOR SIGNS OF CONCRETE DETERIORATION

Cracking occurs over time in virtually all concrete. Cracks vary in depth, width, direction, pattern, location, and cause. Cracks can be either active or dormant (inactive). Active cracks widen, deepen, or migrate through the concrete. Dormant cracks remain unchanged. Some dormant cracks, such as those caused by shrinkage during the curing process, pose no danger, but if left unrepaired, they can provide convenient channels for moisture penetration, which normally causes further damage.

Structural cracks can result from temporary or continued overloads, uneven foundation settling, or original design inadequacies. Structural cracks are active if the overload is continued or if settlement is ongoing; they are dormant if the temporary overloads have been removed, or if differential settlement has stabilized. Thermally-induced cracks result from stresses produced by temperature changes. They frequently occur at the ends or corners of older concrete structures built without expansion joints capable of relieving such stresses. Random surface cracks (also called "map" cracks due to their resemblance to the lines on a road map) that deepen over time and exude a white gel that hardens on the surface are caused by an adverse reaction between the alkalis in a cement and some aggregates.

Since superficial repairs that do not eliminate underlying causes will only tend to aggravate problems, professional consultation is recommended in almost every instance where noticeable cracking occurs.

Spalling is the loss of surface material in patches of varying size. It occurs when reinforcing bars corrode, thus creating high stresses within the concrete. As a result, chunks of concrete pop off from the surface. Similar damage can occur when water absorbed by porous aggregates freezes. Vapor-proof paints or sealants, which trap moisture beneath the surface of the impermeable barrier, also can cause spalling. Spalling may also result from the improper consolidation of concrete during construction. In this case, water-rich cement paste rises to the surface (a condition known as laitance). The surface weakness encourages scaling, which is spalling in thin layers.

Deflection is the bending or sagging of concrete beams, columns, joists, or slabs, and can seriously affect both the strength and structural soundness of concrete. It can be produced by overloading, by corrosion, by inadequate construction techniques (use of low-strength concrete or undersized reinforcing bars, for example), or by concrete creep (long-term shrinkage). Corrosion may cause deflection by weakening and ultimately destroying the bond between the rebar and the concrete, and finally by destroying the reinforcing bars themselves. Deflection of this type is preceded by significant cracking at the bottom of the beams or at column supports. Deflection in a structure without

widespread cracking, spalling, or corrosion is frequently due to concrete creep.

Stains can be produced by alkali-aggregate reaction, which forms a white gel exuding through cracks and hardening as a white stain on the surface. *Efflorescence* is a white, powdery stain produced by the leaching of lime from Portland cement, or by the pre-World War II practice of adding lime to whiten the concrete. Discoloration can also result from metals inserted into the concrete, or from corrosion products dripping onto the surface.

Erosion is the weathering of the concrete surface by wind, rain, snow, and salt air or spray. Erosion can also be caused by the mechanical action of water channeled over concrete, by the lack of drip grooves in beltcourses and sills, and by inadequate drainage.

Corrosion, the rusting of reinforcing bars in concrete, can be a most serious problem. Normally, embedded reinforcing bars are protected against corrosion by being buried within the mass of the concrete and by the high alkalinity of the concrete itself. This protection, however, can be destroyed in two ways. First, by carbonation, which occurs when carbon dioxide in the air reacts chemically with cement paste at the surface and reduces the alkalinity of the concrete. Second, chloride ions from salts combine with moisture to produce an electrolyte that effectively corrodes the reinforcing bars. Chlorides may come from seawater additives in the original mix, or from prolonged contact with salt spray or de-icing salts. Regardless of the cause, corrosion of reinforcing bars produces rust, which occupies significantly more space than the original metal, and causes expansive forces within the concrete. Cracking and spalling are frequent results. In addition, the load-carrying capacity of the structure can be diminished by the loss of concrete, by the loss of bond between reinforcing bars and concrete, and by the decrease in thickness of the reinforcing bars themselves. Rust stains on the surface of the concrete are an indication that internal corrosion is taking place.

PLANNING FOR CONCRETE PRESERVATION

Whatever the causes of deterioration, careful analysis, supplemented by testing, is vital to the success of any historic concrete repair project. Undertaken by experienced engineers or architects, the basic steps in a program of testing and analysis are document review, field survey, testing, and analysis.

Document Review. While plans and specifications for older concrete buildings are rarely extant, they can be an invaluable aid, and every attempt should be made to find them. They may provide information on the intended composition of the concrete mix, or on the type and location of reinforcing bars. Old photographs, records of previous repairs, documents for buildings of the same basic construction or age, and news reports

may also document original construction or changes over time.

Field Survey. A thorough visual examination can assist in locating and recording the type, extent, and severity of stress, deterioration, and damage.

Testing. Two types of testing, on-site and laboratory, can supplement the field condition survey as necessary. On-site, nondestructive testing may include use of a calibrated metal detector or sonic tests to locate the position, depth, and direction of reinforcing bars (see fig. 9). Voids can frequently be detected by "sounding" with a metal hammer. Chains about 30 inches long attached to a 2-foot-long crossbar, dragged over the slabs while listening for hollow reverberations, can locate areas of slabs that have delaminated. In order to find areas of walls that allow moisture to penetrate to the building interior, areas may be tested from the outside by spraying water at the walls and then inspecting the interior for water. If leaks are not readily apparent, sophisticated equipment is available to measure the water permeability of concrete walls.

If more detailed examinations are required, non-destructive instruments are available that can assist in determining the presence of voids or internal cracks, the location and size of rebars, and the strength of the concrete. Laboratory testing can be invaluable in determining the composition and characteristics of historic concrete and in formulating a compatible design mix



Fig. 9. Nondestructive sonic tests are one way of determining the location and soundness of internal reinforcing bars and the hardness of the concrete. There are a variety of other nondestructive tests provided by professional consultants that will help in the evaluation of the structural integrity of concrete prior to major repair work. Photo: Feld, Kaminetzky and Cohen and American Concrete Institute.

for repair materials (see fig. 10). These tests, however, are expensive. A well-equipped concrete laboratory can analyze concrete samples for strength, alkalinity, carbonation, porosity, alkali-aggregate reaction, presence of chlorides, and past composition.

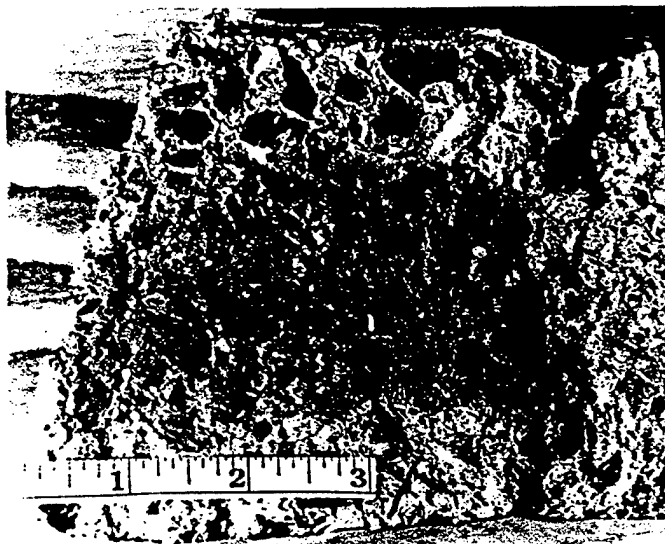

Fig. 10. Testing of actual samples of concrete in the lab may be necessary to determine the strength and condition of the concrete. In this sample, the surface, which is lighter than the sound concrete core, shows that carbonation has taken place. Carbonation reduces the alkalinity in concrete and may hasten corrosion of reinforcing bars close to the surface. Photo: Stella L. Marusin.

Analysis. Analysis is probably the most important step in the process of evaluation. As survey and test results are revised in conjunction with available documentation, the analysis should focus on determining the nature and causes of the concrete problems, on assessing both the short-term and long-term effects of the deterioration, and on formulating proper remedial measures.

CONCRETE REPAIR

Repairs should be undertaken only after the planning measures outlined above have been followed. Repair of historic concrete may consist of either patching the historic material or filling in with new material worked to match the historic material. If replacement is necessary, duplication of historic materials and detailing should be as exact as possible to assure a repair that is functionally and aesthetically acceptable (see fig. 11). The correction and elimination of concrete problems can be difficult, time-consuming, and costly. Yet the temptation to resort to temporary solutions should be avoided, since their failure can expose a building to further and more serious deterioration, and in some cases can mask underlying structural problems that could lead to serious safety hazards (see fig. 12).

Principal concrete repair treatments are discussed below. While they are presented separately here, in practice, preservation projects typically incorporate multiple treatments (see figs. 13a-i).

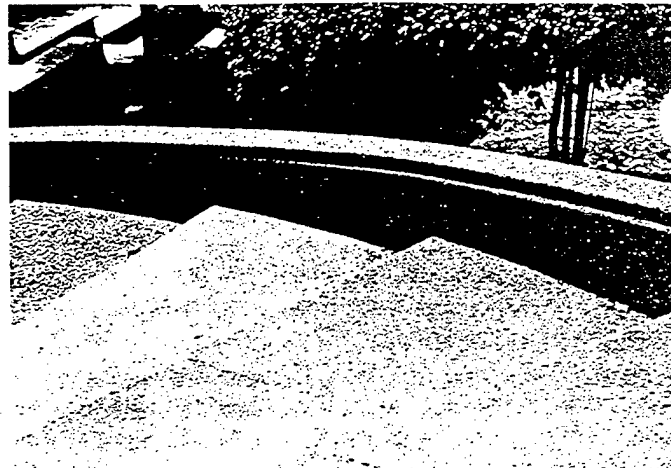

Fig. 11. Meridian Hill, Washington, D.C. (1934). It is important to match the visual qualities, such as color and texture, when repairs or replacement sections are undertaken. In this case, the new replacement step, located second from the left, matches the original pebble-finish surface of the adjacent historic steps. Photo: Sharon C. Park, AIA.



Fig. 12. Without proper preparation and correction of a pre-existing problem, repairs will fail. Insufficient concrete at the surface caused this patch around a reinforcing bar to fail within a year. In this case, a structural engineer should have assessed the need for this rod so close to the surface. Redundant rods are often cut out prior to patching. Photo: Alonzo White.

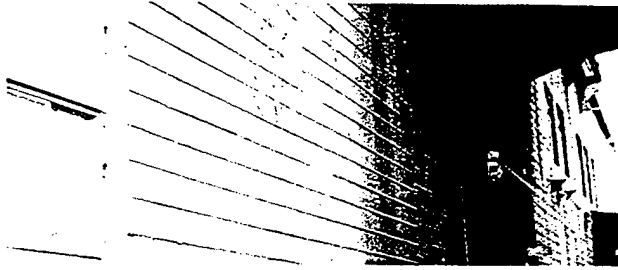

Fig. 13a. Buckling concrete under a painted surface indicates underlying deterioration. It is often difficult to assess the amount of deterioration until the area has been cleaned and examined closely.

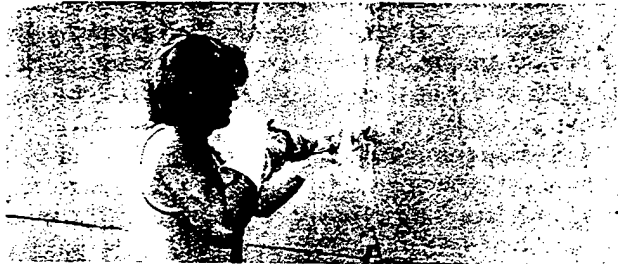

Fig. 13c. Narrow cracks often need to be widened to receive concrete patches. Here a pneumatic chisel is being used.



Fig. 13e. A spalled area of concrete has been cleaned back to a sound surface, and is being coated with a bonding agent to increase adherence of the new concrete patch.



Fig. 13g. A soft brush is used to smooth the patch and to blend it with the adjacent historic concrete.

Fig. 13a-i. Virginia Heating Plant, Arlington, Virginia (1941). This reinforced concrete building exhibits several serious problems, including cracking, spalling, and corrosion of reinforcing bars. As a result of careful planning and close supervision, successful repairs have been carried out. Photos: Alonzo White and Sharon C. Park, AIA.



Fig. 13b. Upon removal of the deteriorated surface, a pocket of poorly mixed concrete (mostly sand and gravel) was easily chiseled out. The reinforcing rods were in good condition.



Fig. 13d. Deteriorated or redundant reinforcing bars are removed after evaluation by a structural engineer. An acetylene torch is being used to cut out the bars.

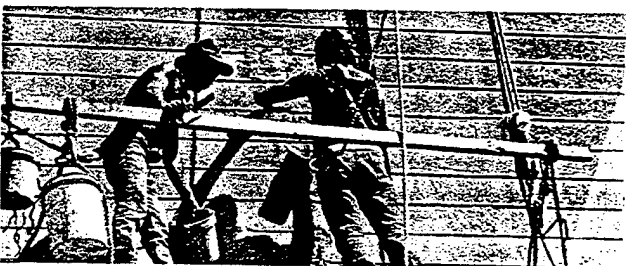

Fig. 13f. Workmen are applying patching concrete and using a trowel to form ridges to match the appearance of the historic concrete ridges that were originally created by the form boards.



Fig. 13h. This active crack at a window sill and in the foundation wall has been filled with a flexible sealant. This area was subsequently painted with a masonry paint compatible with the sealant.

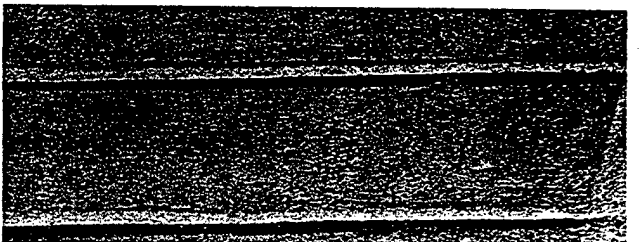

Fig. 13i. Upon completion of all repairs, the building was painted. The finished repair of the deterioration seen in 13a and b is shown in this photograph. The patch matches the texture and detailing of the historic concrete.

Repair of Cracking. Hairline, nonstructural cracks that show no sign of worsening normally need not be repaired. Cracks larger than hairline cracks, but less than approximately one-sixteenth of an inch, can be repaired with a mix of cement and water. If the crack is wider than one-sixteenth of an inch, fine sand should be added to the mix to allow for greater compactibility, and to reduce shrinkage during drying. Field trials will determine whether the crack should be routed (widened and deepened) minimally before patching to allow sufficient penetration of the patching material. To ensure a long-term repair, the patching materials should be carefully selected to be compatible with the existing concrete as well as with subsequent surface treatments such as paint or stucco.

When it is desirable to reestablish the structural integrity of a concrete structure involving dormant cracks, epoxy injection repair should be considered. An epoxy injection repair is made by sealing the crack on both sides of a wall or a structural member with an epoxy mortar, leaving small holes, or "ports" to receive the epoxy resin. After the surface mortar has hardened, epoxy is pumped into the ports. Once the epoxy in the crack has hardened, the surface mortar can be ground off, but the repair may be visually noticeable. (It is possible to inject epoxy without leaving noticeable patches, but the procedure is much more complex.)

Other cracks are active, changing their width and length. Active structural cracks will move as loads are added or removed. Thermal cracks will move as temperatures fluctuate. Thus, expansion-contraction joints may have to be introduced before repair is undertaken. Active cracks should be filled with sealants that will adhere to the sides of the cracks and will compress or expand during crack movement. The design, detailing, and execution of sealant-filled cracks require considerable attention, or else they will detract from the appearance of the historic building.

Random (map) cracks throughout a structure are difficult to correct, and may be unreparable. Repair, if undertaken, requires removing the cracked concrete. A compatible concrete patch to replace the removed concrete is then installed. For some buildings without significant historic finishes, an effective and economical repair material is probably a sprayed concrete coating, troweled or brushed smooth. Because the original concrete will ultimately contaminate new concrete, buildings with map cracks will present continuing maintenance problems.

Repair of Spalling. Repair of spalling entails removing the loose, deteriorated concrete and installing a compatible patch that dovetails into the existing sound concrete. In order to prevent future crack development after the spall has been patched and to ensure that the patch matches the historic concrete, great attention

must be paid to the treatment of rebars, the preparation of the existing concrete substrate, the selection of compatible patch material, the development of good contact between patch and substrate, and the curing of the patch.

Once the deteriorated concrete in a spalled area has been removed, rust on the exposed rebars must be removed by wire brush or sandblasting. An epoxy coating applied immediately over the cleaned rebars will diminish the possibility of further corrosion. As a general rule, if the rebars are so corroded that a structural engineer determines they should be replaced, new supplemental reinforcing bars will normally be required, assuming that the rebar is important to the strength of the concrete. If not, it is possible to cut away the rebar.

Proper preparation of the substrate will ensure a good bond between the patch and the existing concrete. If a large, clean break or other smooth surface is to be patched, the contact area should be roughened with a hammer and chisel. In all cases, the substrate should be kept moist with wet rags, sponges, or running water for at least an hour before placement of the patch. Bonding between the patch and substrate can be encouraged by scrubbing the substrate with cement paste, or by applying a liquid bonding agent to the surface of the substrate. Admixtures such as epoxy resins, latexes, and acrylics in the patch may also be used to increase bonding, but this may cause problems with color matching if the surfaces are to be left unpainted.

Compatible matching of patch material to the existing concrete is critical for both appearance and durability. In general, repair material should match the composition of the original material (as revealed by laboratory analysis) as closely as possible so that the properties of the two materials, such as coefficient of thermal expansion and strength, are compatible. Matching the color and texture of the existing concrete requires special care. Several test batches of patching material should be mixed by adding carefully selected mineral pigments that vary slightly in color. After the samples have cured, they can be compared to the historic concrete and the closest match selected.

Contact between the patch and the existing concrete can be enhanced through the use of anchors, preferably stainless-steel hooked pins, placed in holes drilled into the structure and secured in place with epoxy. Good compaction of the patch material will encourage the contact. Compaction is difficult when the patch is "laid-up" with a trowel without the use of forms; however, by building up thin layers of concrete, each layer can be worked with a trowel to achieve compaction. Board forms will be necessary for large patches. In cases where the existing concrete has a significant finish, care must be taken to pin the form to the existing concrete without marring the surface. The patch in the form can be consolidated by rodding or vibration.

Because formed concrete surfaces normally develop a sheen that does not match the surface texture of most historic concrete, the forms must be removed before the patch has fully set. The surface of the patch must then be finished to match the historic concrete. A brush or wet sponge is particularly useful in achieving matching textures. It may be difficult to match historic concrete surfaces that were textured, as a result of exposed aggregate for example, but it is important that these visual qualities be matched. Once the forms are removed, holes from the bolts must also be patched and finished to match adjacent surfaces.

Regardless of size, a patch containing cement binder (especially Portland cement) will tend to shrink during drying. Adequate curing of the patch may be achieved by keeping it wet for several days with damp burlap bags. It should be noted that although greater amounts of sand will reduce overall shrinkage, patches with a high sand content normally will not bond well to the substrate.

Repair of Deflection. Deflection can indicate significant structural problems and often requires the strengthening or replacement of structural members. Because deflection can lead to structural failure and serious safety hazards, its repair should be left to engineering professionals.

Repair of Erosion. Repair of eroded concrete will normally require replacing lost surface material with a compatible patching material (as outlined above) and then applying an appropriate finish to match the historic appearance. The elimination of water coursing over concrete surfaces should be accomplished to prevent further erosion. If necessary, drip grooves at the underside of overhanging edges of sills, beltcourses, cornices, and projecting slabs should be installed.

SUMMARY

Many early concrete buildings in the United States are threatened by deterioration. Effective protection and maintenance are the keys to the durability of concrete. Even when historic concrete structures are deteriorated, however, many can be saved through preservation projects involving sensitive repair (see figs. 14a-c), or replacement of deteriorated concrete with carefully selected matching material (see figs. 15a-c). Successful restoration of many historic concrete structures in America demonstrates that techniques and materials now available can extend the life of such structures for an indefinite period, thus preserving significant cultural resources.



Fig. 14a. Spalled concrete was most noticeable at locations of concentrated rebars. Deteriorated concrete, the 1960s stucco finish, and corrosion were removed by grit-blasting. Photo: Robert Bell.

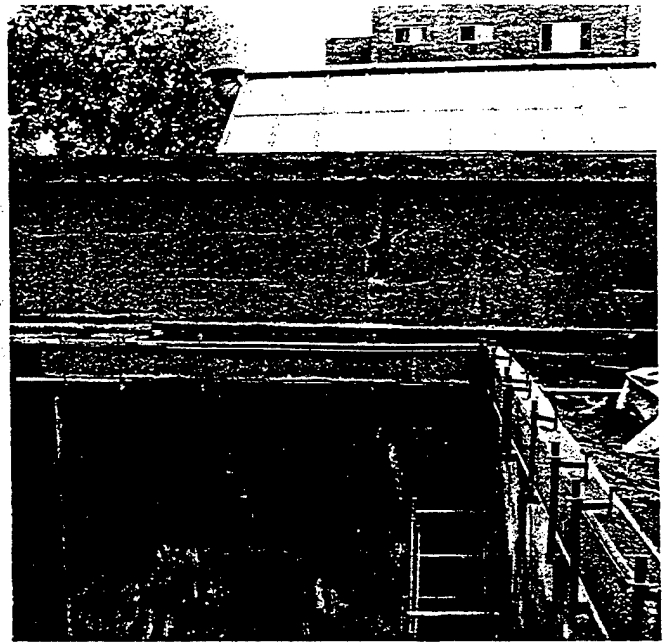

Fig. 14b. Board screeds were attached to the building to recreate the sharp edges of the original detail. Photo: Robert Bell.



Fig. 14c. Once the repair work was complete, the entire building was sprayed with a concrete mixture consisting of pea-gravel, cement, and sand, which was then hand-

troweled. Finally, the building was lightly grit-blasted to remove the cement paste and reproduce the exposed aggregate finish. Photo: Harry J. Hunderman.

Fig. 14a-c. Unity Temple, Oak Park, Illinois (1906). Architect Frank Lloyd Wright used cast-in-place concrete with an exposed aggregate finish. However, reinforcing bars placed too close to the surface resulted in corrosion, cracking, and spalling. A superficial repair in the 1960s coated the surface with a concrete mix and Portland cement paint which produced a stucco-like finish and accelerated deterioration. Repair work was undertaken in 1971.



Fig. 15a. The spindle-type railings were deteriorated beyond repair. The concrete was cracked or broken and the center reinforcing rods were exposed and badly rusted.

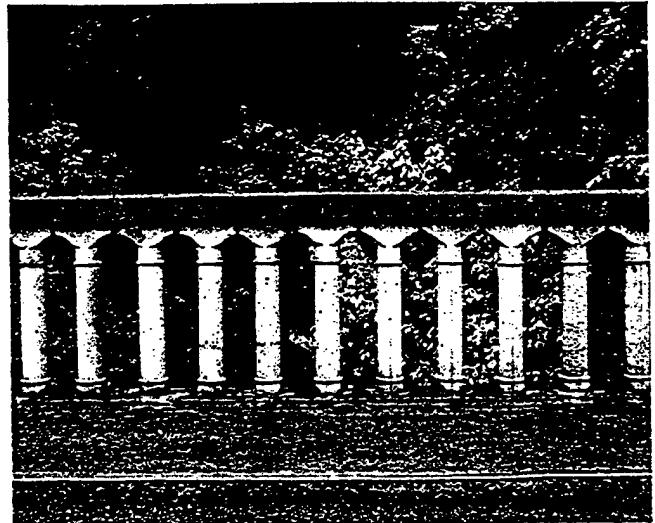

Fig. 15b. Deteriorated spindles were removed. The original 1914 molds were still available and used in casting new concrete spindles, but had they not been available, new molds could have been made to match the originals.



Fig.15c. The new concrete spindles have been installed. This sensitive renovation reused the historic concrete cap railing and stone piers, as they were still in sound condition.

Fig. 15a-c. Columbia River Highway, Oregon. This historic highway overlooking the Columbia River Gorge was constructed from 1913 to 1922 and contains a number of significant concrete bridges. These photos illustrate the sensitive replacement of the concrete spindle-type balusters on the Young Creek (Shepperd's Dell) Bridge of 1914. Photos: James Norman, Oregon Department of Transportation.

BIBLIOGRAPHY

- Concrete Repair and Restoration*. ACI Compilation No. 5. Detroit: American Concrete Institute, 1980. Reprint of *Concrete International: Design & Construction*. Vol. 2, No. 9 (September 1980).
- Condit, Carl W. *American Building: Materials and Techniques from the First Colonial Settlements to the Present*. Chicago: University of Chicago Press, 1968.
- Hime, W.G. "Multitechnique Approach Solves Construction Materials Failure Problems." *American Chemical Society*. Vol. 46, No. 14 (1974).
- Huxtable, Ada Louise. "Concrete Technology in U.S.A." *Progressive Architecture*. (October 1960).
- Onderdonk, Francis S. *The Ferro-Concrete Style*. New York: Architectural Book Publishing Company, Inc., 1928.
- Perenchio, W.F., and Marusin, S.L. "Short-Term Chloride Penetration into Relatively Impermeable Concretes." *Concrete International*. Vol. 5, No. 4 (April 1983), pp. 34-41.
- Pfiefer, D.W., Perenchio, W.F., and Marusin, S.L. "Research on Sealers, Coatings and Specialty Concretes for Barrier Films and Layers on Concrete Structures." *Proceedings of the RILEM Seminar on the Durability of Concrete Structures Under Normal Outdoor Exposure*, Hanover, Federal Republic of Germany, March 26-29, 1984.
- Pfiefer, D.W. "Steel Corrosion Damage on Vertical Concrete, Parts I & II." *Concrete Construction*. (February 1981).
- Prudon, Theodore. "Confronting Concrete Realities." *Progressive Architecture*. (November 1981), pp. 131-137.
- Ropke, John C. *Concrete Problems, Causes & Cures*. New York: McGraw-Hill, 1982.
- Sabnis, Gajanan, ed. *Rehabilitation, Renovation and Preservation of Concrete and Masonry Structures*. ACI-SP-85. Detroit: American Concrete Institute, 1985.

This Preservation Brief was prepared under contract with the National Park Service by William B. Coney, Senior Architect for Wiss, Janney, Elstner Associates, Inc. in Northbrook, Illinois. The author would like to thank others who aided in the research and writing of the Brief: William F. Perenchio, Thomas L. Rewerts, Rexford L. Selbe, John Fraczek, and Bruce S. Kaskell, all of Wiss, Janney, Elstner Associates, Inc. Architects Gordon D. Orr, Jr., and Robert A. Bell provided information on the restoration of Milton House and Unity Temple, respectively. Barbara M. Posadas, Department of History, Northern Illinois University, lent her considerable editorial skill to the entire Brief. Tony C. Liu, James R. Clifton, and Michael J. Paul of the American Concrete Institute Committee 364, reviewed and commented on the manuscript, along with Lee H. Nelson, H. Ward Jandl, Kay D. Weeks, Sharon C. Park, and Michael J. Auer of the National Park Service.

This Preservation Brief was edited by Bonnie J. Halda of the National Park Service, Rocky Mountain Regional Office. Comments on the usefulness of this information should be sent to Lee H. Nelson, FAIA, Chief, Preservation Assistance Division, National Park Service, P.O. Box 37127, U.S. Department of the Interior, Washington, D.C. 20013-7127. This publication is not copyrighted and can be reproduced without penalty. Normal procedures for credit to the authors and the National Park Service are appreciated.

Cover: Baha'i Temple, Wilmette, Illinois (1933). Photo: William B. Coney.

17 PRESERVATION BRIEFS

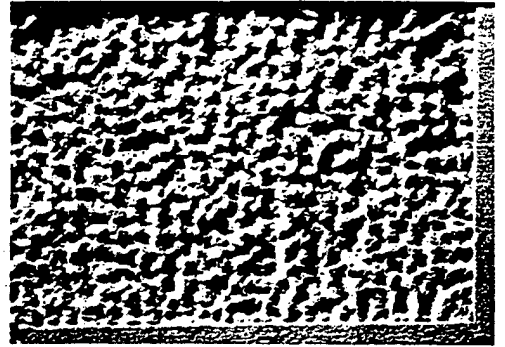

Architectural Character: Identifying the Visual Aspects of Historic Buildings as an Aid to Preserving Their Character

Lee H. Nelson, FAIA

U.S. Department of the Interior
National Park Service
Preservation Assistance Division

The Secretary of the Interior's "Standards for Historic Preservation Projects" embody two important goals: 1) the preservation of historic materials and, 2) the preservation of a building's distinguishing character. Every old building is unique, with its own identity and its own distinctive character. Character refers to all those visual aspects and physical features that comprise the appearance of every historic building. Character-defining elements include the overall shape of the building, its materials, craftsmanship, decorative details, interior spaces and features, as well as the various aspects of its site and environment.

The purpose of this Brief is to help the owner or the architect identify those features or elements that give the building its *visual character* and that should be taken into account in order to preserve them to the maximum extent possible.

There are different ways of understanding old buildings. They can be seen as examples of specific building types, which are usually related to a building's function, such as schools, courthouses or churches. Buildings can be studied as examples of using specific materials such as concrete, wood, steel, or limestone. They can also be considered as examples of an historical period, which is often related to a specific architectural style, such as Gothic Revival farmhouses, one-story bungalows, or Art Deco apartment buildings.

There are many other facets of an historic building besides its functional type, its materials or construction or style that contribute to its historic qualities or significance. Some of these qualities are feelings conveyed by the sense of time and place or in buildings associated with events or people. A complete understanding of any property may require documentary research about its style, construction, function, its furnishings or contents; knowledge about the original builder, owners, and later occupants; and knowledge about the evolutionary history of the building. Even though buildings may be of historic, rather than architectural significance, it is their tangible elements that embody its significance for association with specific events or persons and it is those *tangible elements* both on the exterior and interior that should be preserved.

Therefore, the approach taken in this Brief is limited to identifying those visual and tangible aspects of the historic building. While this may aid in the planning process for carrying out any ongoing or new use or restoration of the building, this approach is not a

substitute for developing an understanding about the significance of an historic building and the district in which it is located.

If the various materials, features and spaces that give a building its visual character are not recognized and preserved, then essential aspects of its character may be damaged in the process of change.

A building's character can be irreversibly damaged or changed in many ways, for example, by inappropriate repointing of the brickwork, by removal of a distinctive side porch, by changes to the window sash, by changes to the setting around the building, by changes to the major room arrangements, by the introduction of an atrium, by painting previously unpainted woodwork, etc.

A Three-Step Process to Identify A Building's Visual Character

This Brief outlines a three-step approach that can be used by anyone to identify those materials, features and spaces that contribute to the visual character of a building. This approach involves first examining the building from afar to understand its overall setting and architectural context; then moving up very close to appreciate its materials and the craftsmanship and surface finishes evident in these materials; and then going into and through the building to perceive those spaces, rooms and details that comprise its interior visual character.

Step 1: Identify the Overall Visual Aspects

Identifying the overall visual character of a building is nothing more than looking at its distinguishing physical aspects without focusing on its details. The major contributors to a building's overall character are embodied

in the general aspects of its *setting*; the *shape* of the building; its *roof* and roof features, such as chimneys or cupolas; the various *projections* on the building, such as porches or bay windows; the *recesses* or voids in a building, such as open galleries, arcades, or recessed balconies; the *openings* for windows and doorways; and finally the various exterior *materials* that contribute to the building's character. Step one involves looking at the building from a distance to understand the character of its site and setting, and it involves walking around the building where that is possible. Some buildings will have one or more sides that are more important than the others because they are more highly visible. This does not mean that the rear of the building is of no value whatever but it simply means that it is less important to the overall character. On the other hand, the rear may have an interesting back porch or offer a private garden space or some other aspect that may contribute to the visual character. Such a general approach to looking at the building and site will provide a better understanding of its overall character without having to resort to an infinitely long checklist of its possible features and details. Regardless of whether a building is complicated or relatively plain, it is these broad categories that contribute to an understanding of the overall character rather than the specifics of architectural features such as moldings and their profiles.

Step 2: Identify the Visual Character at Close Range

Step two involves looking at the building at close range or arm's length, where it is possible to see all the surface qualities of the materials, such as their *color* and *texture*, or surface evidence of craftsmanship or age. In some instances, the visual character is the result of the juxtaposition of materials that are contrastingly different in their color and texture. The surface qualities of the materials may be important because they impart the very sense of craftsmanship and age that distinguishes historic buildings from other buildings. Furthermore, many of these close up qualities can be easily damaged or obscured by work that affects those surfaces. Examples of this could include painting previously unpainted masonry, rotary disk sanding of smooth wood siding to remove paint, abrasive cleaning of tooled stonework, or repointing reddish mortar joints with gray portland cement.

There is an almost infinite variety of surface materials, textures and finishes that are part of a building's character which are fragile and easily lost.

Step 3: Identify the Visual Character of the Interior Spaces, Features and Finishes

Perceiving the character of interior spaces can be somewhat more difficult than dealing with the exterior.

In part, this is because so much of the exterior can be seen at one time and it is possible to grasp its essential character rather quickly. To understand the interior character, it is necessary to move through the spaces one at a time. While it is not difficult to perceive the character of one individual room, it becomes more difficult to deal with spaces that are interconnected and interrelated. Sometimes, as in office buildings, it is the vestibules or lobbies or corridors that are important to the interior character of the building. With other groups of buildings the visual qualities of the interior are related to the plan of the building, as in a church with its axial plan creating a narrow tunnel-like space which obviously has a different character than an open space like a sports pavilion. Thus the shape of the space may be an essential part of its character. With some buildings it is possible to perceive that there is a visual linkage in a sequence of spaces, as in a hotel, from the lobby to the grand staircase to the ballroom. Closing off the openings between those spaces would change the character from visually linked spaces to a series of closed spaces. For example, in a house that has a front and back parlor linked with an open archway, the two rooms are perceived together, and this visual relationship is part of the character of the building. To close off the open archway would change the character of such a residence.

The importance of interior features and finishes to the character of the building should not be overlooked. In relatively simple rooms, the primary visual aspects may be in features such as fireplace mantels, lighting fixtures or wooden floors. In some rooms, the absolute plainness is the character-defining aspect of the interior. So-called secondary spaces also may be important in their own way, from the standpoint of history or because of the family activities that occurred in those rooms. Such secondary spaces, while perhaps historically significant, are not usually perceived as important to the *visual* character of the building. Thus we do not take them into account in the visual understanding of the building.

Conclusion

Using this three-step approach, it is possible to conduct a walk through and identify all those elements and features that help define the visual character of the building. In most cases, there are a number of aspects about the exterior and interior that are important to the character of an historic building. The visual emphasis of this brief will make it possible to ascertain those things that should be preserved because their loss or alteration would diminish or destroy aspects of the historic character whether on the outside, or on the inside of the building.



Overall Visual Character: Shape

The shape of a building can be an important aspect of its overall visual character. The building illustrated here, for example, has a distinctive horizontal box-like shape with the middle portion of the box projecting up an extra story. This building has other visual aspects that help define its overall character, including the pattern of vertical bands of windows, the decorative horizontal bands which separate the base of the building from the upper floors, the dark brown color of the brick, the large arched entranceway, and the castle-like tower behind the building.



Overall Visual Character: Openings

Window and door openings can be important to the overall visual character of historic buildings. This view shows only part of a much larger building, but the windows clearly help define its character, partly because of their shape and rhythm: the upper floor windows are grouped in a 4,3,4,1,4 rhythm, and the lower floor windows are arranged in a regular 1,1,1,... rhythm. The individual windows are tall, narrow and arched, and they are accented by the different colored arched heads, which are connected where there are multiple windows so that the color contrast is a part of its character. If additional windows were inserted in the gap of the upper floors, the character would be much changed, as it would if the window heads were painted to match the color of the brick walls. Photo by Susan I. Dynes



Overall Visual Character: Shape

It should not be assumed that only large or unusual buildings have a shape that is distinctive or identifiable. The front wall of this modest commercial building has a simple three-part shape that is the controlling aspect of its overall visual character. It consists of a large center bay with a two story opening that combines the storefront and the windows above. The upward projecting parapet and the decorative stonework also relate to and emphasize its shape. The flanking narrow bays enframe the side windows and the small iron balconies, and the main entrance doorway into the store. Any changes to the center portion of this three-part shape, could drastically affect the visual character of this building. Photo by Emogene A. Bevit

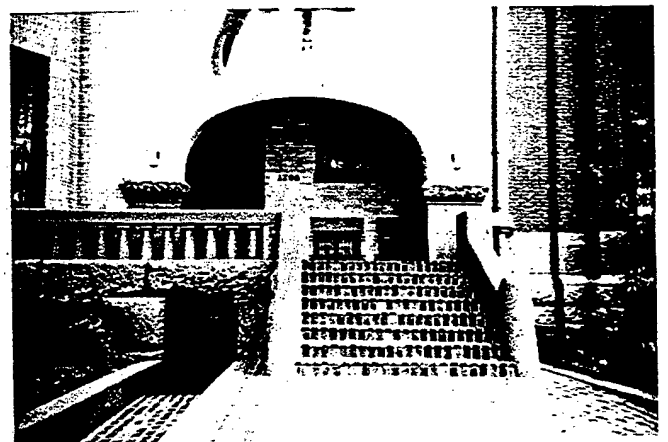

Overall Visual Character: Openings

The opening illustrated here dominates the visual character of this building because of its size, shape, location, materials, and craftsmanship. Because of its relation to the generous staircase, this opening places a strong emphasis on the principal entry to the building. Enclosing this arcade-like entry with glass, for example, would materially and visually change the character of the building. Photo by Lee H. Nelson.

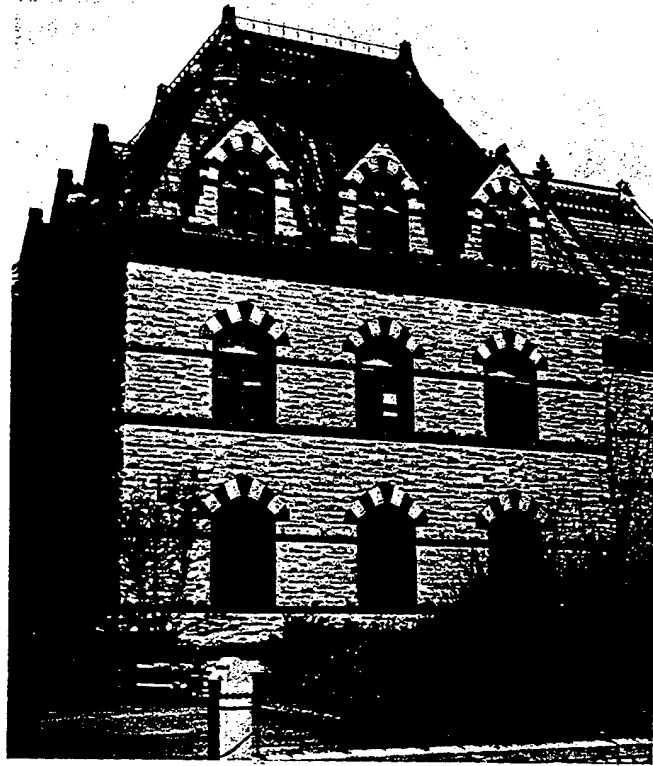

Overall Visual Character: Roof and Related Features

This building has a number of character-defining aspects which include the windows and the decorative stonework, but certainly the roof and its related features are visually important to its overall visual character. The roof is not only highly visible, it has elaborate stone dormers, and it also has decorative metalwork and slatework. The red and black slates of differing sizes and shapes are laid in patterns that extend around the roof of this large and freestanding building. Any changes to this patterned slatework, or to the other roofing details would damage the visual character of the building. Photo by Laurie R. Hammel



Overall Visual Character: Roof and Related Features

On this building, the most important visual aspects of its character are the roof and its related features such as the dormers and chimneys. The roof is important to the visual character because its steepness makes it highly visible, and its prominence is reinforced by the patterned tinwork, the six dormers and the two chimneys. Changes to the roof or its features, such as removal or alterations to the dormers, for example, would certainly change the character of this building. This does not discount the importance of its other aspects, such as the porch, the windows, the brickwork, or its setting; but the roof is clearly crucial to understanding the overall visual character of this building as seen from a distance. Photo by Lee H. Nelson

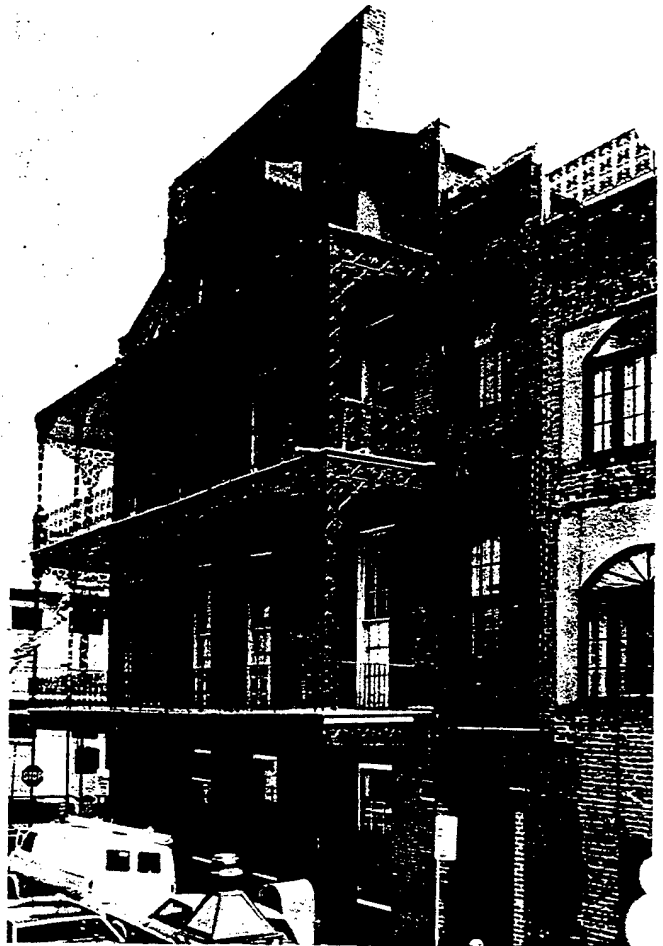

Overall Visual Character: Projections

A projecting porch or balcony can be very important to the overall visual character of almost any building and to the district in which it is located. Despite the size of this building (3 1/2 stories), and its distinctive roofline profile, and despite the importance of the very large window openings, the lacy wrap-around iron balcony is singularly important to the visual character of this building. It would seriously affect the character to remove the balcony, to enclose it, or to replace it with a balcony lacking the same degree of detail of the original material. Photo by Baird M. Smith

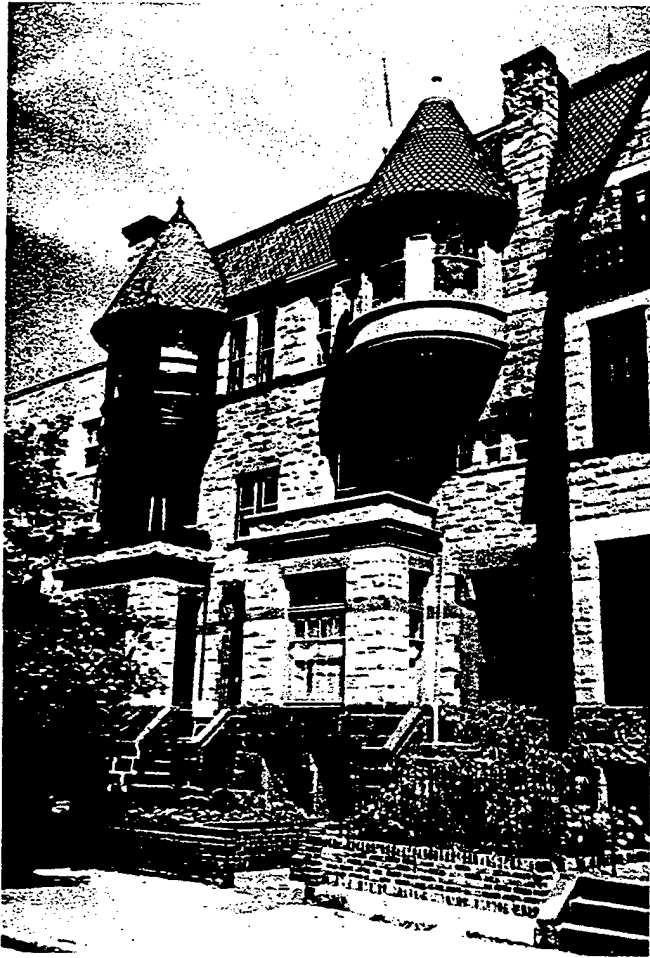

Overall Visual Character: Projections

Since these are row houses, any evaluation of their visual exterior character is necessarily limited to the front and rear walls; and while there are a number of things competing for attention in the front, it is the half round projecting bays with their conical roofs that contribute most prominently to the visual character. Their removal would be a devastating loss to the overall character, but even if preserved, the character could be easily damaged by changes to their color (as seen in the left bay which has been painted a dark color), or changes to their windows, or changes to their tile roofs. Though these houses have other fine features that contribute to the visual character and are worthy of preservation, these half-round bays demonstrate the importance of projecting features on an already rich and complex facade. Because of the repetitive nature of these projecting bays on adjacent row houses, along with the buildings' size, scale, openings, and materials, they also contribute to the overall visual character of the streetscape in the historic district. Any evaluation of the visual character of such a building should take into account the context of this building within the district. Photo by Lee H. Nelson



Overall Visual Character: Projections

Many buildings have projecting features such as porches, bay windows, or overhanging roofs, that help define their overall visual character. This projecting porch because of its size and shape, and because it copies the pitch and material of the main roof, is an important contributor to the visual character of this simple farmhouse. The removal or alteration of this porch would drastically alter the character of this building. If the porch were enclosed with wood or glass, or if gingerbread brackets were added to the porch columns, if the tin roof was replaced with asphalt, or if the porch railing was opened to admit a center stairway, the overall visual character could be seriously damaged. Although this projecting porch is an important feature, almost any other change to this house, such as changes to the window pattern, or changes to the main roof, or changes to the setting, would also change its visual character. Photo by Hugh C. Miller



Overall Visual Character: Trim

If one were to analyze the overall shape or form of this building, it would be seen that it is a gable-roofed house with dormers and a wrap-around porch. It is similar to many other houses of the period. It is the wooden trim on the eaves and around the porch that gives this building its own identify and its special visual character. Although such wooden trim is vulnerable to the elements, and must be kept painted to prevent deterioration; the loss of this trim would seriously damage the overall visual character of this building, and its loss would obliterate much of the close-up visual character so dependent upon craftsmanship for the moldings, carvings, and the see-through jigsaw work. Photo by Hugh C. Miller



Overall Visual Character: Setting

In the process of identifying the overall visual character, the aspect of setting should not be overlooked. Obviously, the setting of urban row houses differs from that of a mansion with a designed landscape. However, there are many instances where the relationship between the building and its place on the streetscape, or its place in the rural environment, in other words its setting, may be an important contributor to its overall character.

In this instance, the corner tower and the arched entryway are important contributors to the visual character of the building itself, but there is also a relationship between the building and the two converging streets that is also an important aspect of this historic building. The curb, sidewalk, fence, and the yard interrelate with each other to establish a setting that is essential to the overall visual character of the historic property. Removing these elements or replacing them with a driveway or parking court would destroy an important visual aspect. Photo by Lee H. Nelson

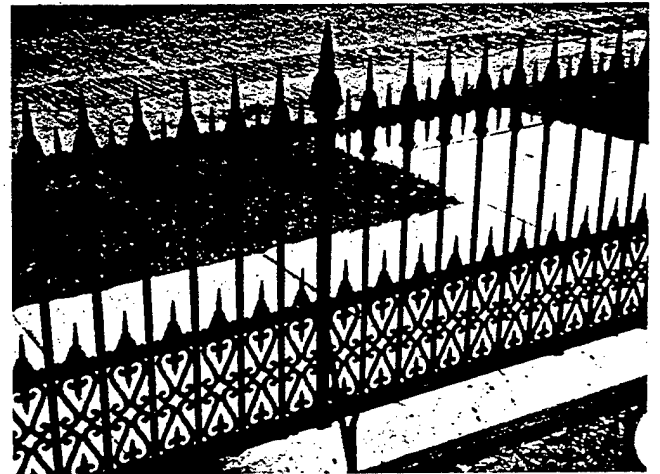

Overall Visual Character: Setting

Among the various visual aspects relating to the setting of an historic property are such site features as gardens, walks, fences, etc. This can include their design and materials. There is a dramatic difference in the visual character between these two fence constructions—one utilizing found materials with no particular regard to their uniformity of size or placement, and the other being a product of the machine age utilizing cast iron components assembled into a pattern of precision and regularity. If the corral fence were to be repaired or replaced with lumberyard materials its character would be dramatically compromised. The rhythm and regularity of the cast iron fence is so important to its visual character that its character could be altered by accidental damage or vandalism, if some of the fence top spikes were broken off thus interrupting the rhythm or pattern. Photos by Lee H. Nelson



Overall Visual Character: Setting

Even architecturally modest buildings frequently will have a setting that contributes to their overall character. In this very urban district, set-backs are the exception, so that the small front yard is something of a luxury, and it is important to the overall character because of its design and materials, which include the iron fence along the sidewalk, the curved walk leading to the porch, and the various plantings. In a district where parking spaces are in great demand, such front yards are sometimes converted to off-street parking, but in this instance, that would essentially destroy its setting and would drastically change the visual character of this historic property. Photo by Lee H. Nelson



Arm's Length Visual Character: Materials

At arm's length, the visual character is most often determined by the surface qualities of the materials and craftsmanship; and while these aspects are often inextricably related, the original choice of materials often plays the dominant role in establishing the close-range character because of the color, texture, or shape of the materials.

In this instance, the variety and arrangement of the materials is important in defining the visual character, starting with the large pieces of broken stone which form the projecting base for the building walls, then changing to a wall of roughly rectangular stones which vary in size, color, and texture, all with accentuated, projecting beads of mortar, then there is a rather precise and narrow band of cut and dressed stones with minimal mortar joints, and finally, the main building walls are composed of bricks, rather uniform in color, with fairly generous mortar joints. It is the juxtaposition and variety of these materials (and of course, the craftsmanship) that is very important to the visual character. Changing the raised mortar joints, for example, would drastically alter the character at arm's length. Photo by Lee H. Nelson

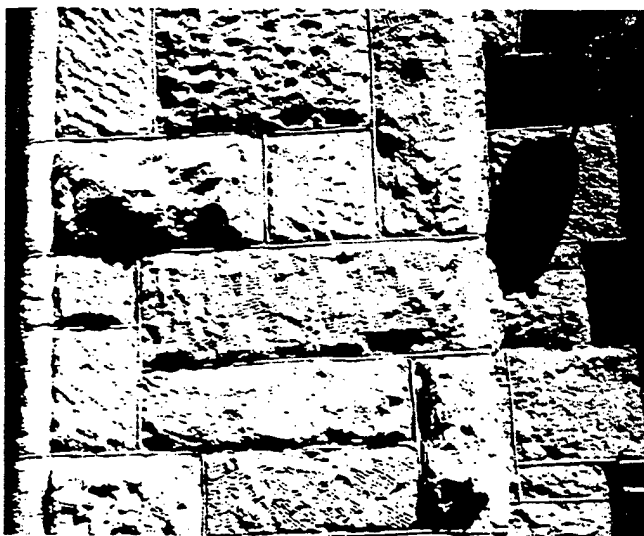

Arm's Length Visual Character: Craft Details

There are many instances where craft details dominate the arm's length visual character. As seen here, the craft details are especially noticeable because the stones are all of a uniform color, and they are all squared off, but their surfaces were worked with differing tools and techniques to create a great variety of textures, resulting in a tour-de-force of craft details. This texture is very important at close range. It was a deliberately contrived surface that is an important contributor to the visual character of this building. Photo by Lee H. Nelson



Arm's Length Visual Character: Craft Details

The arm's length visual character of this building is a combination of the materials and the craft details. Most of the exterior walls of this building consist of early 20th century Roman brick, precisely made, unusually long bricks, in varying shades of yellow-brown, with a noticeable surface spotting of dark iron pyrites. While this brick is an important contributor to the visual character, the related craft details are perhaps more important, and they consist of: unusually precise coursing of the bricks, almost as though they were laid up using a surveyor's level; a row of recessed bricks every ninth course, creating a shadow pattern on the wall; deeply recessed mortar joints, creating a secondary pattern of shadows; and a toothed effect where the bricks overlap each other at the corner of the building. The cumulative effect of this artisanship is important to the arm's length visual character, and it is evident that it would be difficult to match if it were damaged, and the effect could be easily damaged through insensitive treatments such as painting the brickwork or by careless repointing. Photo by Lee H. Nelson

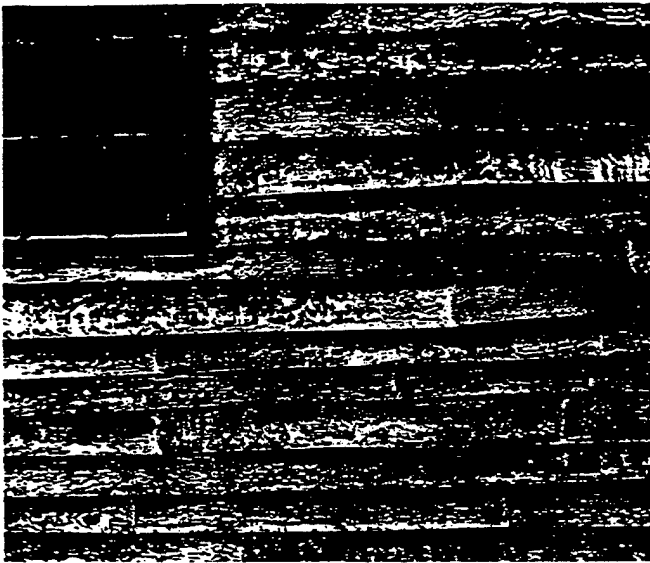

Arm's Length Visual Character: Craft Details

On some buildings, there are subtle aspects of visual character that cannot be perceived from a distance. This is especially true of certain craft details that can be seen only at close range. On this building, it is easily understood that the narrow, unpainted, and weathered clapboards are an important aspect of its overall visual character; but at close range there are a number of subtle but very important craft details that contribute to the handmade quality of this building, and which clearly differentiate it from a building with machine sawn clapboards. The clapboards seen here were split by hand and the bottom edges were not dressed, so that the boards vary in width and thickness, and thus they give a very uneven shadow pattern. Because they were split from oak that is unpainted, there are occasional wavy rays in the wood that stand against the grain. Also noticeable is the fact that the boards are of relatively short lengths, and that they have feather-edged ends that overlap each other, a detail that is very different from butted joints. The occasional large nail heads and the differential silver-gray weathering add to the random quality of the clapboards. All of these qualities contribute to the arm's length visual character. Photo by Lee H. Nelson

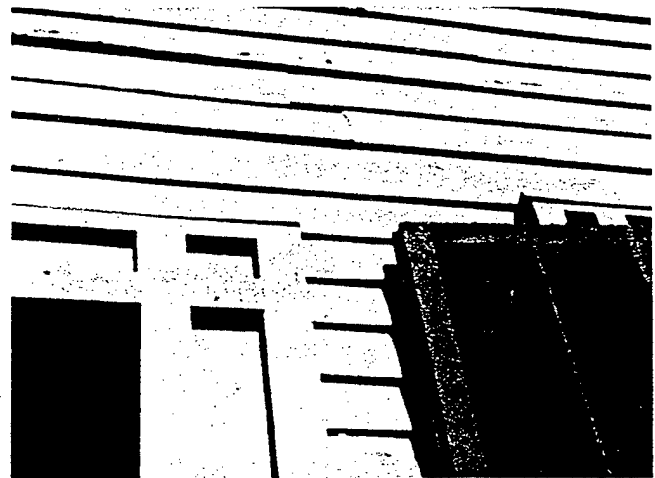

Arm's Length Visual Character: Craft Details

While hand-split clapboards are distinctive visual elements in their own way, machine-sawn and painted wood siding is equally important to the overall visual character in most other instances. At arm's length, however, the machine sawn siding may not be so distinctive; but there might be other details that add visual character to the wooden building, such as the details of wooden trim and louvered shutters around the windows (as seen here), or similar surface textures on other buildings, such as the saw marks on wall shingles, the joints in leaded glass, decorative tinwork on a rain conductor box, the rough surface of pebble-dash stuccowork, or the pebbly surface of exposed aggregate concrete. Such surfaces can only be seen at arm's length and they add to the visual character of a historic building. Photo by Hugh C. Miller

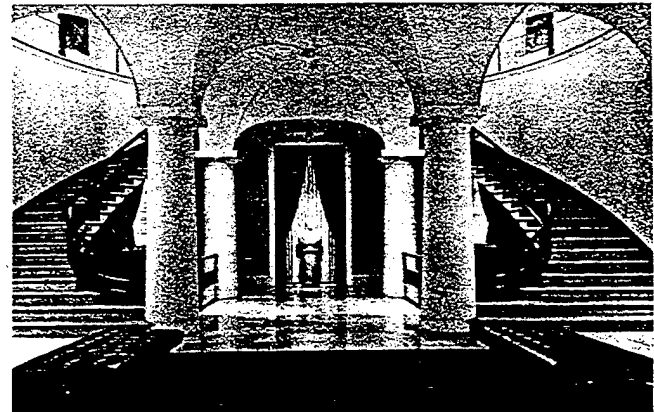

Interior Visual Character: Individually Important Spaces

In assessing the interior visual character of any historic building, it is necessary to ask whether there are spaces that are important to the character of this particular building, whether the building is architecturally rich or modest, or even if it is a simple or utilitarian structure.

The character of the individually important space which is illustrated here is a combination of its size, the twin curving staircases, the massive columns and curving vaulted ceilings, in addition to the quality of the materials in the floor and in the stairs. If the ceiling were to be lowered to provide space for heating ducts, or if the stairways were to be enclosed for code reasons, the shape and character of this space would be damaged, even if there was no permanent physical damage. Such changes can easily destroy the visual character of an individually important interior space. Thus, it is important that the visual aspects of a building's interior character be recognized before planning any changes or alterations. Photo by National Portrait Gallery

Interior Visual Character: Related Spaces

Many buildings have interior spaces that are visually or physically related so that, as you move through them, they are perceived not as separate spaces, but as a sequence of related spaces that are important in defining the interior character of the building. The example which is illustrated here consists of three spaces that are visually linked to each other.

The first of these spaces is the vestibule which is of a generous size and unusual in its own right, but more important, it visually relates to the second space which is the main stairhall.

The hallway is the circulation artery for the building, and leads both horizontally and vertically to other rooms and spaces, but especially to the open and inviting stairway.

The stairway is the third part of this sequence of related spaces, and it provides continuing access to the upper floors.

These related spaces are very important in defining the interior character of this building. Almost any change to these spaces, such as installing doors between the vestibule and the hallway, or enclosing the stair would seriously impact their character and the way that character is perceived. Top photo by Mel Chamowitz, others by John Tennant

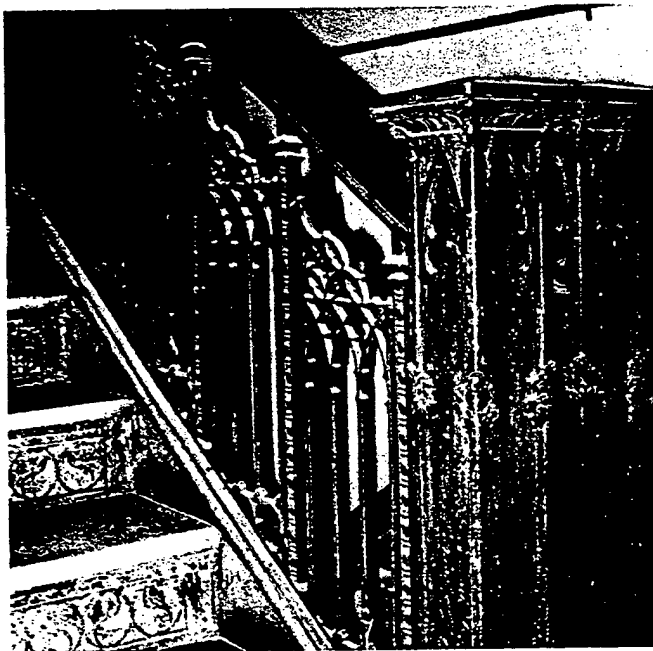

Interior Visual Character: Interior Features

Interior features are three-dimensional building elements or architectural details that are an integral part of the building as opposed to furniture. Interior features are often important in defining the character of an individual room or space. In some instances, an interior feature, like a large and ornamental open stairway may dominate the visual character of an entire building. In other instances, a modest iron stairway (like the one illustrated here) may be an important interior feature, and its preservation would be crucial to preserving the interior character of the building. Such features can also include the obvious things like fireplace mantles, plaster ceiling medallions, or panelling, but they also extend to features like hardware, lighting fixtures, bank tellers cages, decorative elevator doors, etc. Photo by David W. Look

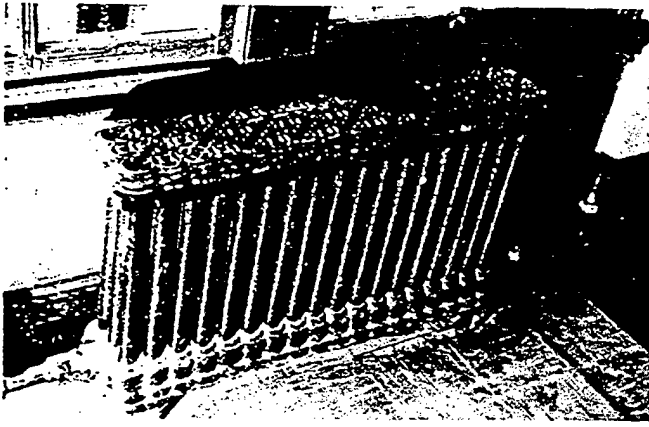

Interior Visual Character: Interior Features

Modern heating or cooling devices usually add little to the interior character of a building; but historically, radiators, for instance, may have contributed to the interior character by virtue of their size or shape, or because of their specially designed bases, piping, and decorative grillage or enclosures. Sometimes they were painted with several colors to highlight their integral, cast-in details. In more recent times, it has been common to overpaint and conceal such distinctive aspects of earlier heating and plumbing devices, so that we seldom have the opportunity to realize how important they can be in defining the character of interior rooms and spaces. For that reason, it is important to identify their character-defining potential, and consider their preservation, retention, or restoration. Photo by David W. Look

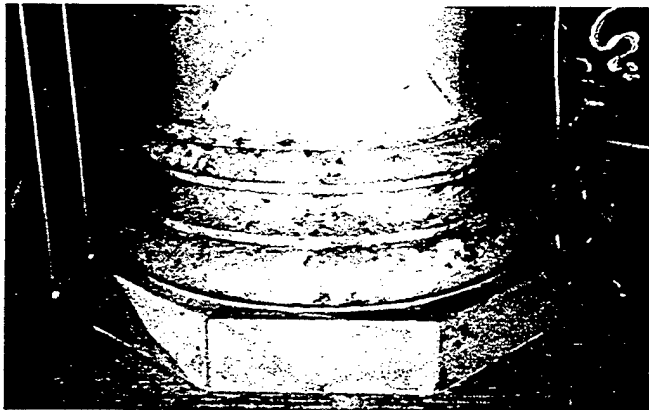

Interior Visual Character: Surface Materials and Finishes

When identifying the visual character of historic interior spaces one should not overlook the importance of those materials and finishes that comprise the surfaces of walls, floors and ceilings. The surfaces may have evidence of either hand-craft or machine-made products that are important contributors to the visual character, including patterned or inlaid designs in the wood flooring, decorative painting practices such as stenciling, imitation marble or wood grain, wallpapering, tinwork, tile floors, etc.

The example illustrated here involves a combination of real marble at the base of the column, imitation marble patterns on the plaster surface of the column (a practice called scagliola), and a tile floor surface that uses small mosaic tiles arranged to form geometric designs in several different colors. While such decorative materials and finishes may be important in defining the interior visual character of this particular building, it should be remembered that in much more modest buildings, the plainness of surface materials and finishes may be an essential aspect of their historic character. Photo by Lee H. Nelson

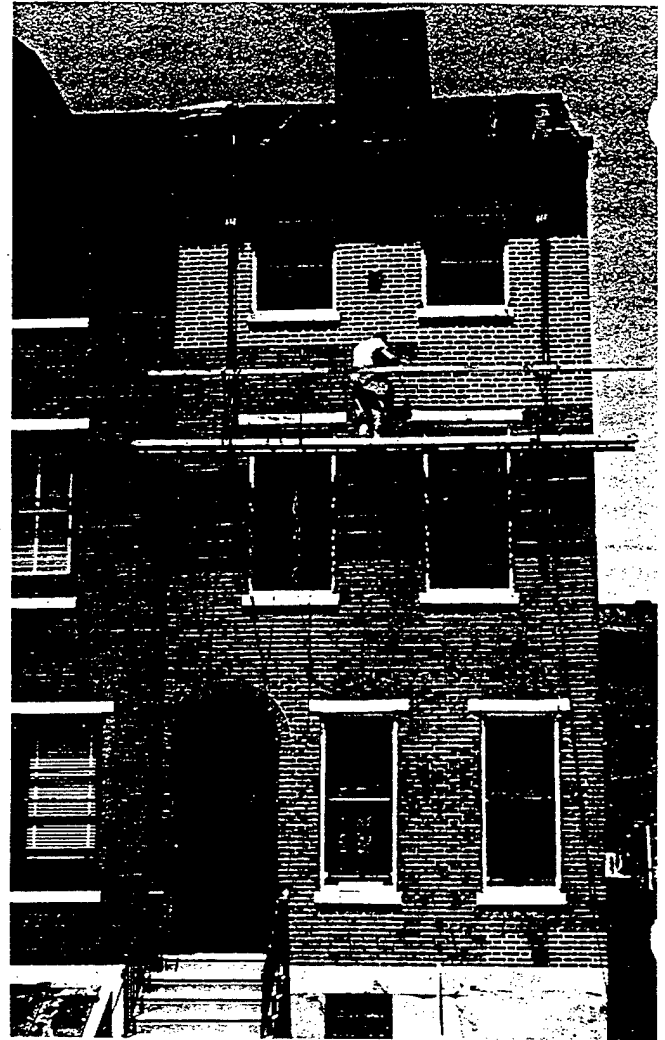

Fragility of A Building's Visual Character

Some aspects of a building's visual character are fragile and are easily lost. This is true of brickwork, for example, which can be irreversibly damaged with inappropriate cleaning techniques or by insensitive repointing practices. At least two factors are important contributors to the visual character of brickwork, namely the brick itself and the craftsmanship. Between these, there are many more aspects worth noting, such as color range of bricks, size and shape variations, texture, bonding patterns, together with the many variable qualities of the mortar joints, such as color, width of joint and tooling. These qualities could be easily damaged by painting the brick, by raking out the joint with power tools, or repointing with a joint that is too wide. As seen here during the process of repointing, the visual character of this front wall is being dramatically changed from a wall where the bricks predominate, to a wall that is visually dominated by the mortar joints. Photo by Lee H. Nelson

The Architectural Character Checklist/Questionnaire

Lee H. Nelson, FAIA
National Park Service

This checklist can be taken to the building and used to identify those aspects that give the building and setting its essential visual qualities and character. This checklist consists of a series of questions that are designed to help in identifying those things that contribute to a building's character. The use of this checklist involves the three-step process of looking for: 1) the overall visual aspects, 2) the visual character at close range, and 3) the visual character of interior spaces, features and finishes.

Because this is a process to identify *architectural character*, it does not address those intangible qualities that give a property or building or its contents its historic significance, instead this checklist is organized on the assumption that historic significance is embodied in those *tangible* aspects that include the building's setting, its form and fabric.

Step One

1. Shape

What is there about the form or shape of the building that gives the building its identity? Is the shape distinctive in relation to the neighboring buildings? Is it simply a low, squat box, or is it a tall, narrow building with a corner tower? Is the shape highly consistent with its neighbors? Is the shape so complicated because of wings, or ells, or differences in height, that its complexity is important to its character? Conversely, is the shape so simple or plain that adding a feature like a porch would change that character? Does the shape convey its historic function as in smoke stacks or silos?

Notes on the Shape or Form of the Building:

2. Roof and Roof Features

Does the roof shape or its steep (or shallow) slope contribute to the building's character? Does the fact that the roof is highly visible (or not visible at all) contribute to the architectural identity of the building? Are certain roof features important to the profile of the building against the sky or its background, such as cupolas, multiple chimneys, dormers, cresting, or weathervanes? Are the roofing materials or their colors or their patterns (such as patterned slates) more noticeable than the shape or slope of the roof?

Notes on the Roof and Roof Features:

3. Openings

Is there a rhythm or pattern to the arrangement of windows or other openings in the walls; like the rhythm of windows in a factory building, or a three-part window in the front bay of a house; or is there a noticeable relationship between the width of the window openings and the wall space between the window openings? Are there distinctive openings, like a large arched entranceway, or decorative window lintels that accentuate the importance of the window openings, or unusually shaped windows, or patterned window sash, like small panes of glass in the windows or doors, that are important to the character? Is the plainness of the window openings such that adding shutters or gingerbread trim would radically change its character? Is there a hierarchy of facades that make the front windows more important than the side windows? What about those walls where the absence of windows establishes its own character?

Notes on the Openings:

4. Projections

Are there parts of the building that are character-defining because they project from the walls of the building like porches, cornices, bay windows, or balconies? Are there turrets, or widely overhanging eaves, projecting pediments or chimneys?

Notes on the Projections:

5. Trim and Secondary Features

Does the trim around the windows or doors contribute to the character of the building? Is there other trim on the walls or around the projections that, because of its decoration or color or patterning contributes to the character of the building? Are there secondary features such as shutters, decorative gables, railings, or exterior wall panels?

Notes on the Trim and Secondary Features:

6. Materials

Do the materials or combination of materials contribute to the overall character of the building as seen from a distance because of their color or patterning, such as broken faced stone, scalloped wall shingling, rounded rock foundation walls, boards and battens, or textured stucco?

Notes on the Materials:

7. Setting

What are the aspects of the setting that are important to the visual character? For example, is the alignment of buildings along a city street and their relationship to the sidewalk the essential aspect of its setting? Or, conversely, is the essential character dependent upon the tree plantings and out buildings which surround the farmhouse? Is the front yard important to the setting of the modest house? Is the specific site important to the setting such as being on a hilltop, along a river, or, is the building placed on the site in such a way to enhance its setting? Is there a special relationship to the adjoining streets and other buildings? Is there a view? Is there fencing, planting, terracing, walkways or any other landscape aspects that contribute to the setting?

Notes on the Setting:

Step Two

8. Materials at Close Range

Are there one or more materials that have an inherent texture that contributes to the close range character, such as stucco, exposed aggregate concrete, or brick textured with vertical grooves? Or materials with inherent colors such as smooth orange-colored brick with dark spots of iron pyrites, or prominently veined stone, or green serpentine stone? Are there combinations of materials, used in juxtaposition, such as several different kinds of stone, combinations of stone and brick, dressed stones for window lintels used in conjunction with rough stones for the wall? Has the choice of materials or the combinations of materials contributed to the character?

Notes on the Materials at Close Range:

9. Craft Details

Is there high quality brickwork with narrow mortar joints? Is there hand-tooled or patterned stonework? Do the walls exhibit carefully struck vertical mortar joints and recessed horizontal joints? Is the wall shinglework laid up in patterns or does it retain evidence of the circular saw marks or can the grain of the wood be seen through the semi-transparent stain? Are there hand split or hand-dressed clapboards, or machine smooth beveled siding, or wood rusticated to look like stone, or Art Deco zigzag designs executed in stucco?

Almost any evidence of craft details, whether handmade or machinemade, will contribute to the character of a building because it is a manifestation of the materials, of the times in which the work was done, and of the tools and processes that were used. It further reflects the effects of time, of maintenance (and/or neglect) that the building has received over the years. All of these aspects are a part of the surface qualities that are seen only at close range.

Notes on the Craft Details:

Step Three

10. Individual Spaces

Are there individual rooms or spaces that are important to this building because of their size, height, proportion, configuration, or function, like the center hallway in a house, or the bank lobby, or the school auditorium, or the ballroom in a hotel, or a courtroom in a county courthouse?

Notes on the Individual Spaces:

11. Related Spaces and Sequences of Spaces

Are there adjoining rooms that are visually and physically related with large doorways or open archways so that they are perceived as related rooms as opposed to separate rooms? Is there an important sequence of spaces that are related to each other, such as the sequence from the entry way to the lobby to the stairway and to the upper balcony as in a theatre; or the sequence in a residence from the entry vestibule to the hallway to the front parlor, and on through the sliding doors to the back parlor; or the sequence in an office building from the entry vestibule to the lobby to the bank of elevators?

Notes on the Related Spaces and Sequences of Spaces:

12. Interior Features

Are there interior features that help define the character of the building, such as fireplace mantels, stairways and balustrades, arched openings, interior shutters, inglenooks, cornices, ceiling medallions, light fixtures, balconies, doors,

windows, hardware, wainscotting, panelling, trim, church pews, courtroom bars, teller cages, waiting room benches?

Notes on the Interior Features:

13. Surface Finishes and Materials

Are there surface finishes and materials that can affect the design, the color or the texture of the interior? Are there materials and finishes or craft practices that contribute to the interior character, such as wooden parquet floors, checkerboard marble floors, pressed metal ceilings, fine hardwoods, grained doors or marbled surfaces, or polychrome painted surfaces, or stenciling, or wallpaper that is important to the historic character? Are there surface finishes and materials that, because of their plainness, are imparting the essential character of the interior such as hard or bright, shiny wall surfaces of plaster or glass or metal?

Notes on the Surface Finishes and Materials:

14. Exposed Structure

Are there spaces where the exposed structural elements define the interior character such as the exposed posts, beams, and trusses in a church or train shed or factory? Are there rooms with decorative ceiling beams (non-structural) in bungalows, or exposed vigas in adobe buildings?

Notes on the Exposed Structure:

This concludes the three-step process of identifying the visual aspects of historic buildings and is intended as an aid in preserving their character and other distinguishing qualities. It is not intended as a means of understanding the significance of historical properties or districts, nor of the events or people associated with them. That can only be done through other kinds of research and investigation.

This Preservation Brief was originally developed as a slide talk/methodology in 1982 to discuss the use of the Secretary of the Interior's Standards for Rehabilitation in relation to preserving historic character; and it was amplified and modified in succeeding years to help guide preservation decisionmaking, initially for maintenance personnel in the National Park Service. A number of people contributed to the evolution of the ideas presented here. Special thanks go to Emogene Bevit and Gary Hume, primarily for the many and frequent discussions relating to this approach in its evolutionary stages; to Mark Fram, Ontario Heritage Foundation, Toronto, for suggesting several additions to the Checklist; and more recently, to my co-workers, both in Washington and in our regional offices, especially Ward Jandl, Sara Blumenthal, Charles Fisher, Sharon Park, AIA, Jean Travers, Camille Martone, Susan Dynes, Michael Auer, Anne Grimmer, Kay Weeks, Betsy Chittenden, Patrick Andrus, Carol Shull, Hugh Miller, FAIA, Jerry Rogers, Paul Alley, David Look, AIA, Margaret Pepin-Donat, Bonnie Halda, Keith Everett, Thomas Keohan, the Preservation Services Division, Mid-Atlantic Region, and several reviewers in state preservation offices, especially Ann Haaker, Illinois; and Stan Graves, AIA, Texas; for providing very critical and constructive review of the manuscript.

This publication has been prepared pursuant to the National Historic Preservation Act of 1966, as amended. Comments on the usefulness of this information are welcomed and can be sent to Mr. Nelson, Preservation Assistance Division, National Park Service, U.S. Department of the Interior, P.O. Box 37127, Washington, D.C. 20013-7127. This publication is not copyrighted and can be reproduced without penalty. Normal procedures for credit to the author and the National Park Service are appreciated.

18 PRESERVATION BRIEFS



Rehabilitating Interiors in Historic Buildings

Identifying and Preserving Character-defining Elements

H. Ward Jandl

U.S. Department of the Interior National Park Service
Preservation Assistance Division Technical Preservation Services

A floor plan, the arrangement of spaces, and features and applied finishes may be individually or collectively important in defining the historic character of the building and the purpose for which it was constructed. Thus, their identification, retention, protection, and repair should be given prime consideration in every preservation project. Caution should be exercised in developing plans that would radically change character-defining spaces or that would obscure, damage or destroy interior features or finishes.

While the exterior of a building may be its most prominent visible aspect, or its "public face," its interior can be even more important in conveying the building's history and development over time. Rehabilitation within the context of the Secretary of the Interior's Standards for Rehabilitation calls for the preservation of exterior *and* interior portions or features of the building that are significant to its historic, architectural and cultural values.

Interior components worthy of preservation may include the building's plan (sequence of spaces and circulation patterns), the building's spaces (rooms and volumes), individual architectural features, and the various finishes and materials that make up the walls, floors, and ceilings. A theater auditorium or sequences of rooms such as double parlors or a lobby leading to a stairway that ascends to a mezzanine may comprise a building's most important spaces. Individual rooms may contain notable features such as plaster cornices, millwork, parquet wood floors, and hardware. Paints, wall coverings, and finishing techniques such as graining, may provide color, texture, and patterns which add to a building's unique character.

Virtually all rehabilitations of historic buildings involve some degree of interior alteration, even if the buildings are to be used for their original purpose. Interior rehabilitation proposals may range from preservation of existing features and spaces to total reconfigurations. In some cases, depending on the building, restoration may be warranted to preserve historic character adequately; in other cases, extensive alterations may be perfectly acceptable.

This Preservation Brief has been developed to assist building owners and architects in identifying and evaluating those elements of a building's interior that

contribute to its historic character and in planning for the preservation of those elements in the process of *rehabilitation*. The guidance applies to all building types and styles, from 18th century churches to 20th century office buildings. The Brief does not attempt to provide specific advice on preservation techniques and treatments, given the vast range of buildings, but rather suggests general preservation approaches to guide construction work.

Identifying and Evaluating the Importance of Interior Elements Prior to Rehabilitation

Before determining what uses might be appropriate and before drawing up plans, a thorough professional assessment should be undertaken to identify those tangible architectural components that, prior to rehabilitation, convey the building's sense of time and place—that is, its "historic character." Such an assessment, accomplished by walking through and taking account of each element that makes up the interior, can help ensure that a truly compatible use for the building, one that requires minimal alteration to the building, is selected.

Researching The Building's History

A review of the building's history will reveal why and when the building achieved significance or how it contributes to the significance of the district. This information helps to evaluate whether a particular rehabilitation treatment will be appropriate to the building and whether it will preserve those tangible components of the building that convey its significance for association with specific events or persons along with its architectural importance. In this regard, National Register files may prove useful in explaining why and for what period of time the

building is significant. In some cases research may show that later alterations are significant to the building; in other cases, the alterations may be without historical or architectural merit, and may be removed in the rehabilitation.

Identifying Interior Elements

Interiors of buildings can be seen as a series of primary and secondary spaces. The goal of the assessment is to identify which elements contribute to the building's character and which do not. Sometimes it will be the sequence and flow of spaces, and not just the individual rooms themselves, that contribute to the building's character. This is particularly evident in buildings that have strong central axes or those that are consciously asymmetrical in design. In other cases, it may be the size or shape of the space that is distinctive. The importance of some interiors may not be readily apparent based on a visual inspection; sometimes rooms that do not appear to be architecturally distinguished are associated with important persons and events that occurred within the building.

Primary spaces, are found in all buildings, both monumental and modest. Examples may include foyers, corridors, elevator lobbies, assembly rooms, stairhalls, and parlors. Often they are the places in the building that the public uses and sees; sometimes they are the most architecturally detailed spaces in the building, carefully proportioned and finished with costly materials. They may be functionally and architecturally related to the building's external appearance. In a simpler building, a primary space may be distinguishable only by its location, size, proportions, or use. Primary spaces are always important to the character of the building and should be preserved.

Secondary spaces are generally more utilitarian in appearance and size than primary spaces. They may include areas and rooms that service the building, such as bathrooms, and kitchens. Examples of secondary spaces in a commercial or office structure may include storerooms, service corridors, and in some cases, the offices themselves. Secondary spaces tend to be of less importance to the building and may accept greater change in the course of work without compromising the building's historic character.

Spaces are often designed to interrelate both visually and functionally. The **sequence of spaces**, such as vestibule-hall-parlor or foyer-lobby-stair-auditorium or stairhall-corridor-classroom, can define and express the building's historic function and unique character. Important sequences of spaces should be identified and retained in the rehabilitation project.

Floor plans may also be distinctive and characteristic of a style of architecture or a region. Examples include Greek Revival and shotgun houses. Floor plans may also reflect social, educational, and medical theories of the period. Many 19th century psychiatric institutions, for example, had plans based on the ideas of Thomas Kirkbride, a Philadelphia doctor who authored a book on asylum design.

In addition to evaluating the relative importance of the various spaces, the assessment should identify architectural features and finishes that are part of the



Figure 1. This architect-designed interior reflects early 20th century American taste: the checkerboard tile floor, wood wainscot, coffered ceiling, and open staircase are richly detailed and crafted by hand. Not only are the individual architectural features worthy of preservation, but the planned sequence of spaces—entry hall, stairs, stair landings, and loggia—imparts a grandeur that is characteristic of high style residences of this period. This interior is of Greystone, Los Angeles, California. Photography for HABS by Jack E. Boucher



Figure 2. The interiors of mills and industrial buildings frequently are open, unadorned spaces with exposed structural elements. While the new uses to which this space could be put are many—retail, residential, or office—the generous floor-to-ceiling height and exposed truss system are important character-defining features and should be retained in the process of rehabilitation.

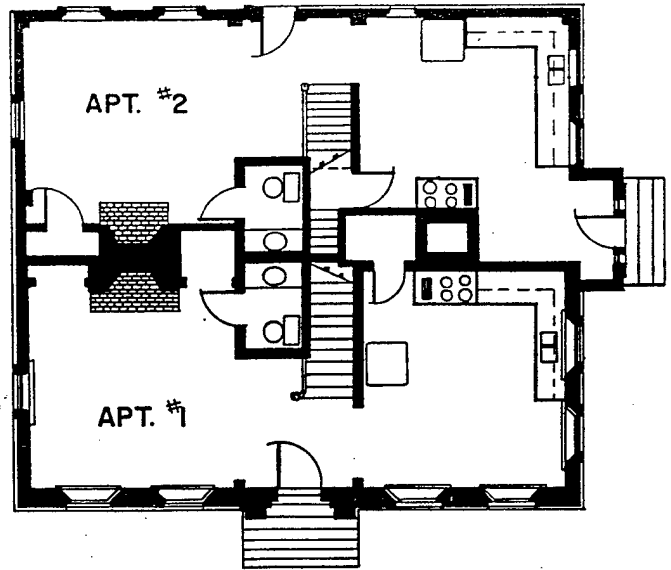
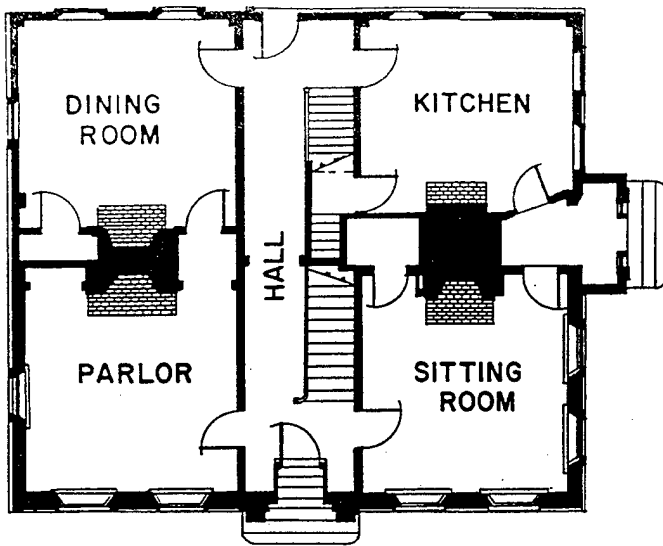

Figure 3. The floor plan at left is characteristic of many 19th century Greek Revival houses, with large rooms flanking a central hall. In the process of rehabilitation, the plan (at right) was drastically altered to accommodate two duplex apartments. The open stair was replaced with one that is enclosed, two fireplaces were eliminated, and Greek Revival trim around windows and doors was removed. The symmetry of the rooms themselves was destroyed with the insertion of bathrooms and kitchens. Few vestiges of the 19th century interior survived the rehabilitation. Drawing by Neal A. Vogel

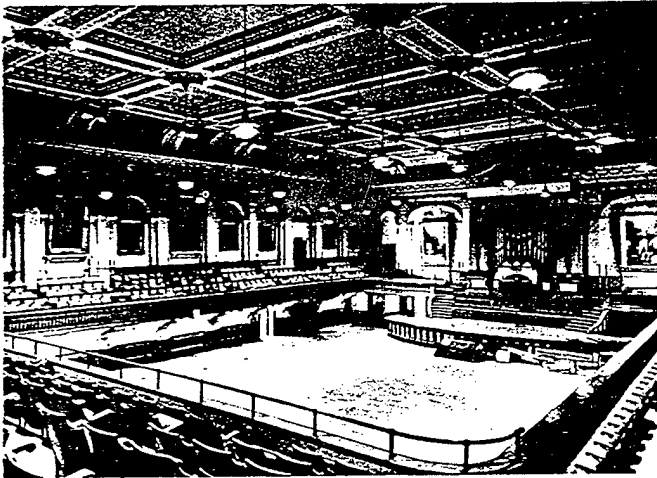

Figure 4. Many institutional buildings possess distinctive spaces or floor plans that are important in conveying the significance of the property. Finding new compatible uses for these buildings and preserving the buildings' historic character can be a difficult, if not impossible, task. One such case is Mechanics Hall in Worcester, Massachusetts, constructed between 1855 and 1857. This grand hall, which occupies the entire third floor of the building, could not be subdivided without destroying the integrity of the space.

interior's history and character. Marble or wood wainscoting in corridors, elevator cabs, crown molding, baseboards, mantels, ceiling medallions, window and door trim, tile and parquet floors, and staircases are among those features that can be found in historic buildings. Architectural finishes of note may include grained woodwork, marbleized columns, and plastered walls. Those features that are characteristic of the building's style and period of construction should, again, be retained in the rehabilitation.



Figure 5. The interior of a simply detailed worker's house of the 19th century may be as important historically as the richly ornamented interior seen in figure 1. Although the interior of this house has not been properly maintained, the wide baseboards, flat window trim, and four-panel door are characteristic of workers' housing during this period and deserve retention during rehabilitation.

Features and finishes, even if machine-made and not exhibiting particularly fine craftsmanship, may be character-defining; these would include pressed metal ceilings and millwork around windows and doors. The interior of a plain, simple detailed worker's house of the 19th century may be as important historically as a richly ornamented, high-style townhouse of the same period. Both resources, if equally intact, convey important information about the early inhabitants and deserve the same careful attention to detail in the preservation process.

The location and condition of the building's existing heating, plumbing, and electrical systems also need to be noted in the assessment. The visible features of historic systems—radiators, grilles, light fixtures, switchplates, bathtubs, etc.—can contribute to the overall character of the building, even if the systems themselves need upgrading.

Assessing Alterations and Deterioration

In assessing a building's interior, it is important to ascertain the extent of alteration and deterioration that may have taken place over the years; these factors help determine what degree of change is appropriate in the project. Close examination of existing fabric and original floorplans, where available, can reveal which alterations have been **additive**, such as new partitions inserted for functional or structural reasons and historic features covered up rather than destroyed. It can also reveal which have been **subtractive**, such as key walls removed and architectural features destroyed. If an interior has been modified by additive changes and if these changes have not acquired significance, it may be relatively easy to remove the alterations and return the interior to its historic appearance. If an interior has been greatly altered through subtractive changes, there may be more latitude in making further alterations in the process of rehabilitation because the integrity of the interior has been compromised. At the same time, if the interior had been exceptionally significant, and solid documentation on its historic condition is available, reconstruction of the missing features may be the preferred option.

It is always a recommended practice to photograph interior spaces and features thoroughly prior to rehabilitation. Measured floor plans showing the existing conditions are extremely useful. This documentation is invaluable in drawing up rehabilitation plans and specifications and in assessing the impact of changes to the property for historic preservation certification purposes.

Drawing Up Plans and Executing Work

If the historic building is to be rehabilitated, it is critical that the new use not require substantial alteration of distinctive spaces or removal of character-defining architectural features or finishes. If an interior loses the physical vestiges of its past as well as its historic function, the sense of time and place associated both with the building and the district in which it is located is lost.

The recommended approaches that follow address common problems associated with the rehabilitation of historic interiors and have been adapted from the Secretary of the Interior's Standards for Rehabilitation and Guidelines for Rehabilitating Historic Buildings. Adherence to these suggestions can help ensure that character-defining interior elements are preserved in the process of rehabilitation. The checklist covers a range of situations and is not intended to be all-inclusive. Readers are strongly encouraged to review the full set of guidelines before undertaking any rehabilitation project.

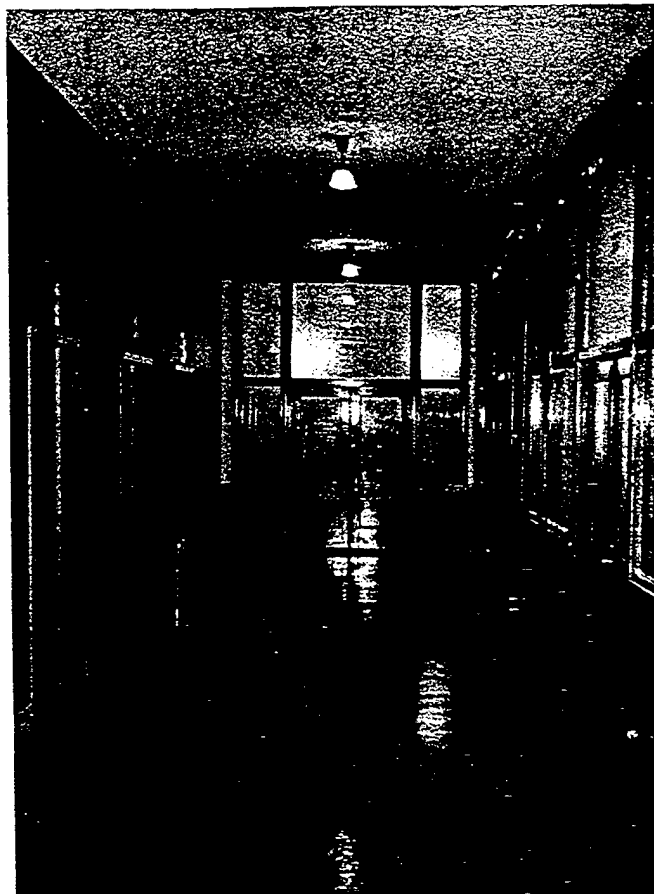

Figure 6. This corridor, located in the historic Monadnock Building in Chicago, has glazed walls, oak trim, and marble wainscotting, and is typical of those found in late 19th and early 20th century office buildings. Despite the simplicity of the features, a careful attention to detail can be noted in the patterned tile floor, bronze mail chute, and door hardware. The retention of corridors like this one should be a priority in rehabilitation projects involving commercial buildings.

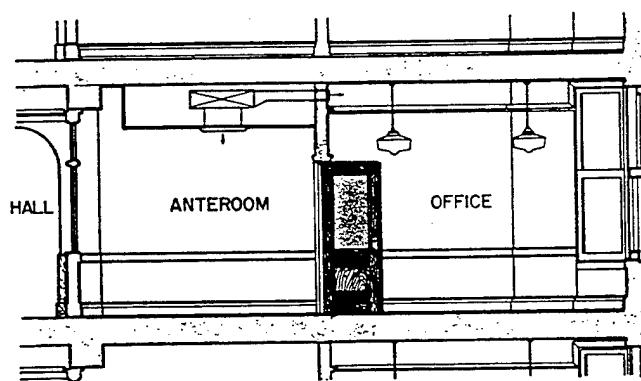

Figure 7. When the Monadnock Building was rehabilitated, architects retained the basic floor plan on the upper floors consisting of a double-loaded corridor with offices opening onto it. The original floor-to-ceiling height in the corridors and outside offices—the most important spaces—was maintained by installing needed air conditioning ductwork in the less important anterooms. In this way, the most significant interior spaces were preserved intact. Drawing by Neal A. Vogel

Recommended Approaches for Rehabilitating Historic Interiors

1. Retain and preserve floor plans and interior spaces that are important in defining the overall historic character of the building. This includes the size, configuration, proportion, and relationship of rooms and corridors; the relationship of features to spaces; and the spaces themselves such as lobbies, reception halls, entrance halls, double parlors, theaters, auditoriums, and important industrial or commercial use spaces. Put service functions required by the building's new use, such as bathrooms, mechanical equipment, and office machines, in secondary spaces.
2. Avoid subdividing spaces that are characteristic of a building type or style or that are directly associated with specific persons or patterns of events. Space may be subdivided both vertically through the insertion of new partitions or horizontally through insertion of new floors or mezzanines. The insertion of new additional floors should be considered only when they will not damage or destroy the structural system or obscure, damage, or destroy character-defining spaces, features, or finishes. If rooms have already been subdivided through an earlier insensitive renovation, consider removing the partitions and restoring the room to its original proportions and size.
3. Avoid making new cuts in floors and ceilings where such cuts would change character-defining spaces and the historic configuration of such spaces. Inserting of a new atrium or a lightwell is appropriate only in very limited situations where the existing interiors are not historically or architecturally distinguished.
4. Avoid installing dropped ceilings below ornamental ceilings or in rooms where high ceilings are part of the building's character. In addition to obscuring or destroying significant details, such treatments will also change the space's proportions. If dropped ceilings are installed in buildings that lack character-defining spaces, such as mills and factories, they should be well set back from the windows so they are not visible from the exterior.
5. Retain and preserve interior features and finishes that are important in defining the overall historic character of the building. This might include columns, doors, cornices, baseboards, fireplaces and mantels, paneling, light fixtures, elevator cabs, hardware, and flooring; and wallpaper, plaster, paint, and finishes such as stenciling, marbleizing, and graining; and other decorative materials that accent interior features and provide color, texture, and patterning to walls, floors, and ceilings.
6. Retain stairs in their historic configuration and location. If a second means of egress is required, consider constructing new stairs in secondary spaces. (For guidance on designing compatible new additions, see Preservation Brief 14, "New Exterior Additions to Historic Buildings.") The application of fire-retardant coatings, such as intumescent paints; the installation of fire suppression systems, such as sprinklers; and the construction of glass enclosures can in many cases permit retention of stairs and other character-defining features.
7. Retain and preserve visible features of early mechanical systems that are important in defining the overall historic character of the building, such as radiators, vents, fans, grilles, plumbing fixtures, switchplates, and lights. If new heating, air conditioning, lighting and plumbing systems are installed, they should be done in a way that does not destroy character-defining spaces, features and finishes. Ducts, pipes, and wiring should be installed as inconspicuously as possible: in secondary spaces, in the attic or basement if possible, or in closets.
8. Avoid "furring out" perimeter walls for insulation purposes. This requires unnecessary removal of window trim and can change a room's proportions. Consider alternative means of improving thermal performance, such as installing insulation in attics and basements and adding storm windows.
9. Avoid removing paint and plaster from traditionally finished surfaces, to expose masonry and wood. Conversely, avoid painting previously unpainted millwork. Repairing deteriorated plasterwork is encouraged. If the plaster is too deteriorated to save, and the walls and ceilings are not highly ornamented, gypsum board may be an acceptable replacement material. The use of paint colors appropriate to the period of the building's construction is encouraged.
10. Avoid using destructive methods—propane and butane torches or sandblasting—to remove paint or other coatings from historic features. Avoid harsh cleaning agents that can change the appearance of wood. (For more information regarding appropriate cleaning methods, consult Preservation Brief 6, "Dangers of Abrasive Cleaning to Historic Buildings.")

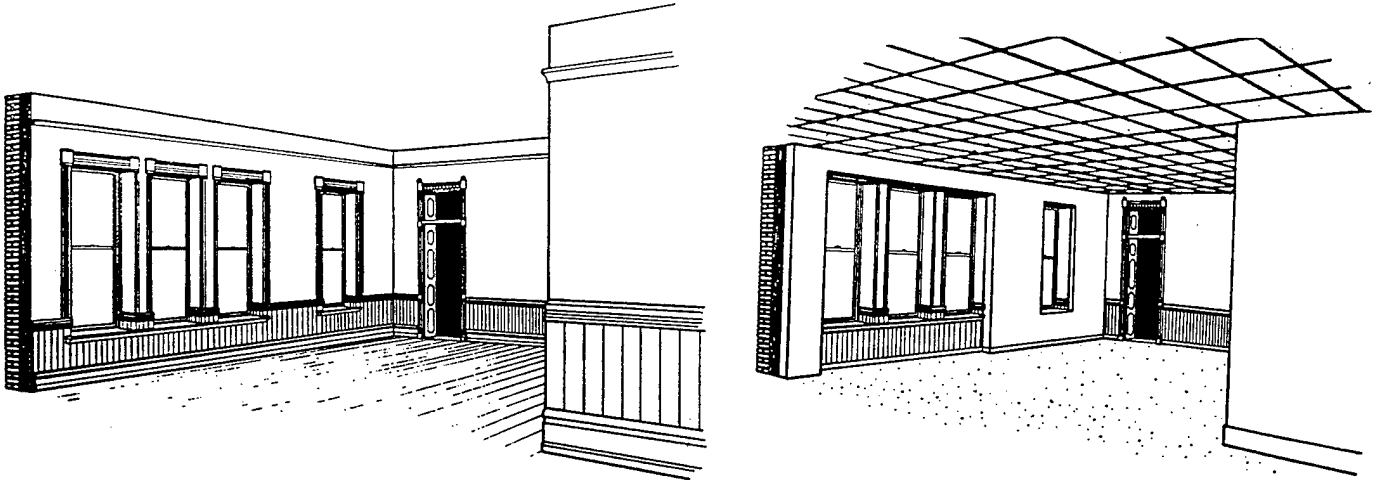

Figure 8. Furring out exterior walls to add insulation and suspending new ceilings to hide ductwork and wiring can change a room's proportions and can cause interior features to appear fragmented. In this case, a school was converted into apartments, and individual classrooms became living rooms, bedrooms, and kitchens. On the left is an illustration of a classroom prior to rehabilitation; note the generous floor-to-ceiling height, wood wainscoting, molded baseboard, picture molding, and Eastlake Style door and window trim. After rehabilitation, on the right, only fragments of the historic detailing survive: the ceiling has been dropped below the picture molding, the remaining wainscoting appears to be randomly placed, and some of the window trim has been obscured. Together with the subdivision of the classrooms, these rehabilitation treatments prevent a clear understanding of the original classroom's design and space. If thermal performance must be improved, alternatives to furring out walls and suspending new ceilings, such as installing insulation in attics and basements, should be considered. Drawings by Neal A. Vogel



Figure 9. The tangible reminders of early mechanical systems can be worth saving. In this example, in the Old Post Office in Washington, D.C., radiators encircle Corinthian columns in a decorative manner. Note, too, the period light fixtures. These features were retained when the building was rehabilitated as retail and office space. Photo: Historic American Buildings Survey



Figure 10. In this case plaster has been removed from perimeter walls, leaving brick exposed. In removing finishes from historic masonry walls, not only is there a loss of historic finish, but raw, unfinished walls are exposed, giving the interior an appearance it never had. Here, the exposed brick is of poor quality and the mortar joints are wide and badly struck. Plaster should have been retained and repaired, as necessary.



Figure 11. These dramatic "before" and "after" photographs show a severely deteriorated space restored to its original elegance: plaster has been repaired and painted, the scagliola columns have been restored to match marble using traditional craft techniques, and missing decorative metalwork has been re-installed in front of the windows. Although some reorganization of the space took place, notably the relocation of the front desk, the overall historic character of the space has been preserved. These views are of the lobby in the Willard Hotel, Washington, D.C. Credit: Commercial Photographers (left); Carol M. Highsmith (right)

Meeting Building, Life Safety and Fire Codes

Buildings undergoing rehabilitation must comply with existing building, life safety and fire codes. The application of codes to specific projects varies from building to building, and town to town. Code requirements may make some reuse proposals impractical; in other cases, only minor changes may be needed to bring the project into compliance. In some situations, it may be possible to obtain a code variance to preserve distinctive interior features. (It should be noted that the Secretary's Standards for Rehabilitation take precedence over other regulations and codes in determining whether a rehabilitation project qualifies for Federal tax benefits.) A thorough understanding of the applicable regulations and close coordination with code officials, building inspectors, and fire marshals can prevent the alteration of significant historic interiors.

Sources of Assistance

Rehabilitation and restoration work should be undertaken by professionals who have an established reputation in the field.

Given the wide range of interior work items, from ornamental plaster repair to marble cleaning and the application of graining, it is possible that a number of specialists and subcontractors will need to be brought in to bring the project to completion. State Historic Preservation Officers and local preservation organizations may be a useful source of information in this regard. Good sources of information on appropriate preservation techniques for specific interior features and finishes include the *Bulletin* of the Association for Preservation Technology and *The Old-House Journal*; other useful publications are listed in the bibliography.

Protecting Interior Elements During Rehabilitation

Architectural features and finishes to be preserved in the process of rehabilitation should be clearly marked on plans *and at the site*. This step, along with careful supervision of the interior demolition work and protection against arson and vandalism, can prevent the unintended destruction of architectural elements that contribute to the building's historic character.

Protective coverings should be installed around architectural features and finishes to avoid damage in the course of construction work and to protect workers. Staircases and floors, in particular, are subjected to dirt and heavy wear, and the risk exists of incurring costly or irreparable damage. In most cases, the best, and least costly, preservation approach is to design and construct a protective system that enables stairs and floors to be used yet protects them from damage. Other architectural features such as mantels, doors, wainscoting, and decorative finishes may be protected by using heavy canvas or plastic sheets.

Summary

In many cases, the interior of a historic building is as important as its exterior. The careful identification and evaluation of interior architectural elements, after undertaking research on the building's history and use, is critically important *before* changes to the building are contemplated. Only *after* this evaluation should new uses be decided and plans be drawn up. The best rehabilitation is one that preserves and protects those rooms, sequences of spaces, features and finishes that define and shape the overall historic character of the building.

This Preservation Brief is based on a discussion paper prepared by the author for a National Park Service regional workshop held in March, 1987, and on a paper written by Gary Hume, "Interior Spaces in Historic Buildings," October, 1987. Appreciation is extended to the staff of Technical Preservation Services Branch and to the staff of NPS regional offices who reviewed the manuscript and provided many useful suggestions. Special thanks are given to Neal A. Vogel, a summer intern with the NPS, for many of the illustrations in this Brief.

This publication has been prepared pursuant to the National Historic Preservation Act of 1966, as amended. Preservation Briefs 18 was developed under the editorship of Lee H. Nelson, FAIA, Chief, Preservation Assistance Division, National Park Service, U.S. Department of the Interior, P.O. Box 37127, Washington, D.C. 20013-7127. Comments on the usefulness of this information are welcomed and may be sent to Mr. Nelson at the above address. This publication is not copyrighted and can be reproduced without penalty. Normal procedures for credit to the author and the National Park Service are appreciated.

Selected Reading List

There are few books written exclusively on preserving historic interiors, and most of these tend to focus on residential interiors: Articles on the subject appear regularly in *The Old-House Journal*, the *Bulletin of the Association for Preservation Technology*, and *Historic Preservation Magazine*.

Ferro, Maximilian L., and Melissa L. Cook. *Electric Wiring and Lighting in Historic American Buildings*. New Bedford, Massachusetts: AFC/A Nortek Company, 1984.

Fisher, Charles E. *Temporary Protection of Historic Stairways During Rehabilitation Work*. Preservation Tech Note. Washington, D.C.: Preservation Assistance Division, National Park Service, U.S. Department of the Interior, 1985.

Jennings, Jan, and Herbert Gottfried. *American Vernacular Interior Architecture 1870-1940*. New York: Van Nostrand Reinhold Company, 1988.

Johnson, Ed. *Old House Woodwork Restoration: How to Restore Doors, Windows, Walls, Stairs and Decorative Trim to Their Original Beauty*. Englewood Cliffs, New Jersey: Prentice-Hall, Inc., 1983.

Labine, Clem, and Carolyn Flaherty (editors). *The Old-House Journal Compendium*. Woodstock, New York: The Overlook Press, 1980.

The Secretary of the Interior's Standards for Rehabilitation and Guidelines for Rehabilitating Historic Buildings. Washington, D.C.: Preservation Assistance Division, National Park Service, U.S. Department of the Interior, rev. 1983.

U.S. Department of Housing and Urban Development. *Rehabilitation Guidelines*, volumes 1-11. Washington, D.C.: U.S. Department of Housing and Urban Development, 1980-84.

Winkler, Gail Caskey, and Roger W. Moss. *Victorian Interior Decoration: American Interiors 1830-1900*. New York: Henry Holt and Company, 1986.

October 1988

Cover: Detail of carving on interior shutter. Hammond-Harwood House, Annapolis, Maryland.

24 PRESERVATION BRIEFS

Heating, Ventilating, and Cooling Historic Buildings: Problems and Recommended Approaches

Sharon C. Park, AIA



U.S. Department of the Interior
National Park Service
Cultural Resources
Preservation Assistance

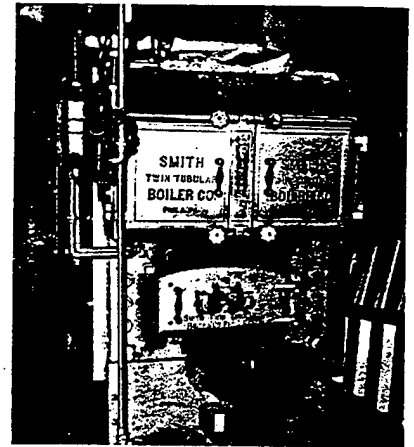

The need for modern mechanical systems is one of the most common reasons to undertake work on historic buildings. Such work includes upgrading older mechanical systems, improving the energy efficiency of existing buildings, installing new heating, ventilation or air conditioning (HVAC) systems, or—particularly for museums—installing a climate control system with humidification and dehumidification capabilities. Decisions to install new HVAC or climate control systems often result from concern for occupant health and comfort, the desire to make older buildings marketable, or the need to provide specialized environments for operating computers, storing artifacts, or displaying museum collections. Unfortunately, occupant comfort and concerns for the objects within the building are sometimes given greater consideration than the building itself. In too many cases, applying modern standards of interior climate comfort to historic buildings has proven detrimental to historic materials and decorative finishes.

This Preservation Brief underscores the importance of careful planning in order to balance the preservation objectives with interior climate needs of the building. It is not intended as a technical guide to calculate tonnage or to size piping or ductwork. Rather, this Brief identifies some of the problems associated with installing mechanical systems in historic buildings and recommends approaches to minimizing the physical and visual damage associated with installing and maintaining these new or upgraded systems.

Historic buildings are not easily adapted to house modern precision mechanical systems. Careful planning must be provided early on to ensure that decisions made during the design and installation phases of a new system are appropriate. Since new mechanical and other related systems, such as electrical and fire suppression, can use up to 10% of a building's square footage and 30%–40% of an overall rehabilitation budget, decisions must be made in a systematic and coordinated manner. The installation of inappropriate

mechanical systems may result in any or all of the following:

- large sections of historic materials are removed to install or house new systems.
- historic structural systems are weakened by carrying the weight of, and sustaining vibrations from, large equipment.
- moisture introduced into the building as part of a new system migrates into historic materials and causes damage, including biodegradation, freeze/thaw action, and surface staining.
- exterior cladding or interior finishes are stripped to install new vapor barriers and insulation.
- historic finishes, features, and spaces are altered by dropped ceilings and boxed chases or by poorly located grilles, registers, and equipment.
- systems that are too large or too small are installed before there is a clearly planned use or a new tenant.

For historic properties it is critical to understand what spaces, features, and finishes are historic in the building, what should be retained, and what the *realistic* heating, ventilating, and cooling needs are for the building, its occupants, and its contents. A systematic approach, involving preservation planning, preservation design, and a follow-up program of monitoring and maintenance, can ensure that new systems are successfully added—or existing systems are suitably upgraded—while preserving the historic integrity of the building.

No set formula exists for determining what type of mechanical system is best for a specific building. Each building and its needs must be evaluated separately. Some buildings will be so significant that every effort must be made to protect the historic materials and systems in place with minimal intrusion from new systems. Some buildings will have museum collections that need special climate control. In such cases, curatorial needs must be considered—but not to the ultimate detriment of the historic building resource. Other

buildings will be rehabilitated for commercial use. For them, a variety of systems might be acceptable, as long as significant spaces, features, and finishes are retained.

Most mechanical systems require upgrading or replacement within 15-30 years due to wear and tear or the availability of improved technology. Therefore, historic buildings should not be greatly altered or otherwise sacrificed in an effort to meet short-term systems objectives.

History of Mechanical Systems

The history of mechanical systems in buildings involves a study of inventions and ingenuity as building owners, architects, and engineers devised ways to improve the interior climate of their buildings. Following are highlights in the evolution of heating, ventilating, and cooling systems in historic buildings.

Eighteenth Century. Early heating and ventilation in America relied upon common sense methods of *managing the environment* (see figure 1). Builders purposely sited houses to capture winter sun and prevailing summer cross breezes; they chose materials that could help protect the inhabitants from the elements, and took precautions against precipitation and damaging drainage patterns. The location and sizes of windows, doors, porches, and the floor plan itself often evolved to maximize ventilation. Heating was primarily from fireplaces or stoves and, therefore, was at the source of delivery. In 1744, Benjamin Franklin designed his "Pennsylvania stove" with a fresh air intake in order to maximize the heat radiated into the room and to minimize annoying smoke.

Thermal insulation was rudimentary—often wattle and daub, brick and wood nogging. The comfort level for occupants was low, but the relatively small difference between internal and external temperatures and relative humidity allowed building materials to expand and contract with the seasons.

Regional styles and architectural features reflected regional climates. In warm, dry and sunny climates, thick adobe walls offered shelter from the sun and kept the inside temperatures cool. Verandas, courtyards, porches, and high ceilings also reduced the impact of the sun. Hot and humid climates called for elevated living floors, louvered grilles and shutters, balconies, and interior courtyards to help circulate air.

Nineteenth Century. The industrial revolution provided the technological means for *controlling the environment* for the first time (see figure 2). The dual developments of steam energy from coal and industrial mass production made possible early central heating systems with distribution of heated air or steam using metal ducts or pipes. Improvements were made to early wrought iron boilers and by late century, steam and low pressure hot water radiator systems were in common use, both in offices and residences. Some large institutional buildings heated air in furnaces and distributed it throughout the building in brick flues with a network of metal pipes delivering heated air to individual rooms. Residential designs of the period often used gravity hot air systems utilizing decorative floor and ceiling grilles.

Ventilation became more scientific and the introduc-



1. Eighteenth century and later vernacular architecture depended on the siting of the building, deciduous trees, cross ventilation, and the placement of windows and chimneys to maximize winter heating and natural summer cooling. Regional details, as seen in this Virginia house, include external chimneys and a separate summer kitchen to reduce fire risk and isolate heat in the summer. Photo: NPS Files.



2. Nineteenth century buildings continued to use architectural features as porches, cupolas, and awnings to make the buildings more comfortable in summer, but heating was greatly improved by hot water or steam radiators. Photo: NPS Files

tion of fresh air into buildings became an important component of heating and cooling. Improved forced air ventilation became possible in mid-century with the introduction of power-driven fans. Architectural features such as porches, awnings, window and door transoms, large open-work iron roof trusses, roof monitors, cupolas, skylights and clerestory windows helped to dissipate heat and provide healthy ventilation.

Cavity wall construction, popular in masonry structures, improved the insulating qualities of a building and also provided a natural cavity for the dissipation of moisture produced on the interior of the building. In some buildings, cinder chips and broken masonry filler between structural iron beams and jack arch floor vaults provided thermal insulation as well as fire-proofing. Mineral wool and cork were new sources of lightweight insulation and were forerunners of contemporary batt and blanket insulation.

The technology of the age, however, was not sufficient to produce "tight" buildings. There was still only a moderate difference between internal and external temperatures. This was due, in part, to the limitations of early insulation, the almost exclusive use of single glazed windows, and the absence of air-tight construction. The presence of ventilating fans and the reliance on architectural features, such as operable windows, cupolas and transoms, allowed sufficient air movement to keep buildings well ventilated. Building materials could behave in a fairly traditional way, expanding and contracting with the seasons.

Twentieth century. The twentieth century saw intensive development of new technologies and the notion of fully *integrating mechanical systems* (see figure 3). Oil and gas furnaces developed in the nineteenth century were improved and made more efficient, with electricity becoming the critical source of power for building systems in the latter half of the century. Forced air heating systems with ducts and registers became popular for all types of buildings and allowed architects to experiment with architectural forms free from mechanical encumbrances. In the 1920s large-scale theaters and auditoriums introduced central air conditioning, and by mid-century forced air systems which combined heating and air conditioning in the same ductwork set a new standard for comfort and convenience. The combination and coordination of a variety of systems came together in the post-World War II highrise buildings; complex heating and air conditioning plants, electric elevators, mechanical towers, ventilation fans, and full service electric lighting were integrated into the building's design.

The insulating qualities of building materials improved. Synthetic materials, such as spun fiberglass batt insulation, were fully developed by mid-century. Prototypes of insulated thermal glazing and integral storm window systems were promoted in construction journals. Caulking to seal out perimeter air around window and door openings became a standard construction detail.

The last quarter of the twentieth century has seen making HVAC systems more energy efficient and better integrated. The use of vapor barriers to control moisture migration, thermally efficient windows, caulking

and gaskets, compressed thin wall insulation, has become standard practice. New integrated systems now combine interior climate control with fire suppression, lighting, air filtration, temperature and humidity control, and security detection. Computers regulate the performance of these integrated systems based on the time of day, day of the week, occupancy, and outside ambient temperature.



3. The circa 1928 Fox Theater in Detroit, designed by C. Howard Crane, was one of the earliest twentieth century buildings to provide air conditioning to its patrons. The early water-cooled system was recently restored. Commercial and highrise buildings of the twentieth century were able, mostly through electrical power, to provide sophisticated systems that integrated many building services. Photo: William Kessler and Associates, Architects.

Climate Control and Preservation

Although twentieth century mechanical systems technology has had a tremendous impact on making historic buildings comfortable, the introduction of these new systems in older buildings is not without problems. The attempt to meet and maintain modern climate control standards *may in fact be damaging to historic resources*. Modern systems are often over-designed to compensate for inherent inefficiencies of some historic buildings materials and plan layouts. Energy retrofit measures, such as installing exterior wall insulation and vapor barriers or the sealing of operable window and vents, ultimately affect the performance and can reduce the life of aging historic materials.

In general, the greater the differential between the interior and exterior temperature and humidity levels, the greater the potential for damage. As natural vapor pressure moves moisture from a warm area to a colder, dryer area, condensation will occur on or in building materials in the colder area (see figure 4). Too little humidity in winter, for example, can dry and crack historic wooden or painted surfaces. Too much humidity in winter causes moisture to collect on cold surfaces, such as windows, or to migrate into walls. As a result, this condensation deteriorates wooden or metal windows and causes rotting of walls and wooden structural elements, dampening insulation and holding moisture against exterior surfaces. Moisture migration through walls can cause the corrosion of metal anchors, angles, nails or wire lath, can blister and peel exterior paint, or can leave efflorescence and salt deposits on exterior masonry. In cold climates, freeze-thaw damage can result from excessive moisture in external walls.

To avoid these types of damage to a historic building, it is important to understand how building components work together as a system. Methods for controlling interior temperature and humidity and improving ventilation must be considered in any new or upgraded HVAC or climate control system. While certain energy retrofit measures will have a positive effect on the overall building, installing effective vapor barriers in historic walls is difficult and often results in destruction of significant historic materials (see figure 5).



5. The installation of vapor retarders in walls of historic buildings in an effort to contain interior moisture can cause serious damage to historic finishes as shown here. In this example, all the wall plaster and lath have been stripped in preparation for a vapor barrier prior to replastering. Controlling interior temperature and relative humidity can be more effective than adding insulation and vapor barriers to historic perimeter walls. Photo: Ernest A. Conrad, P.E.

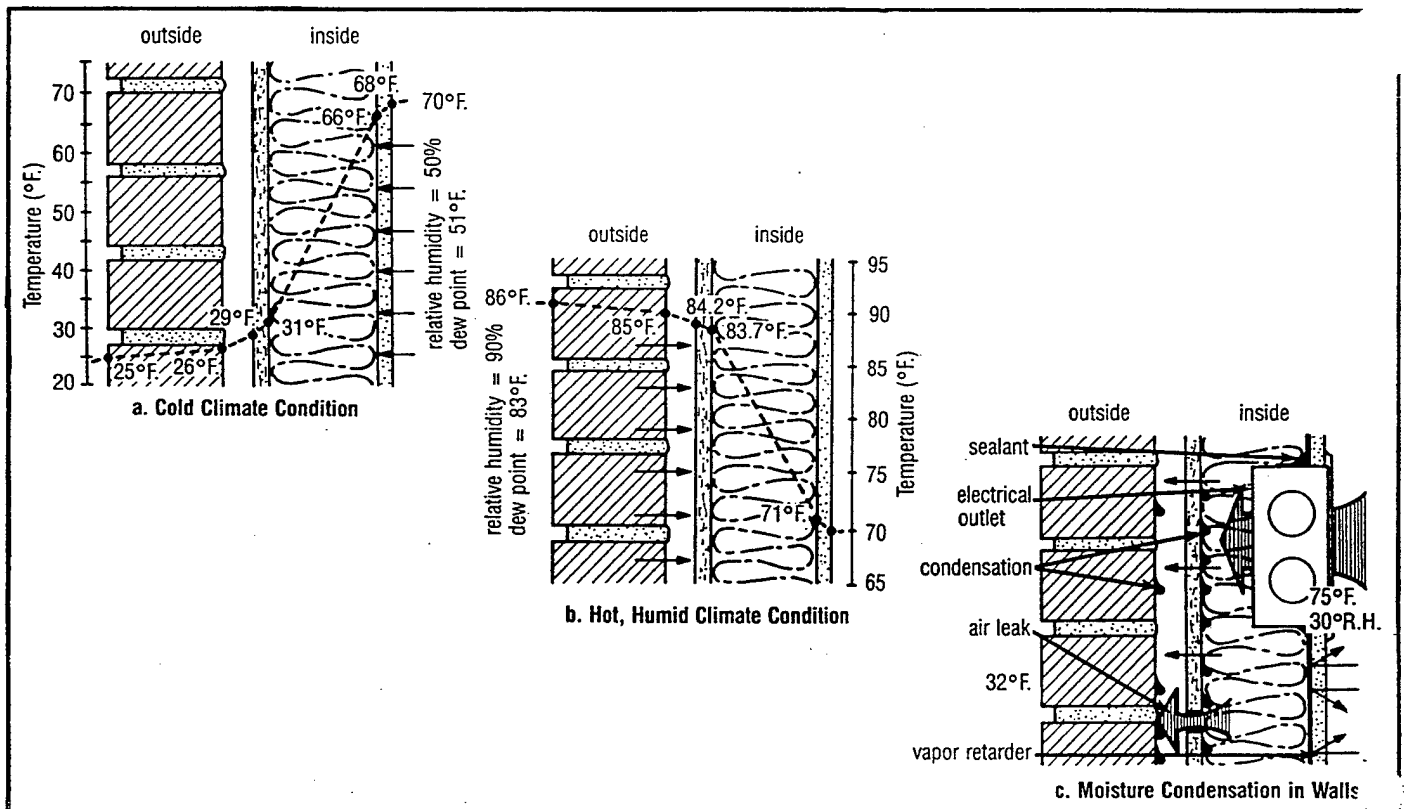

4. Mechanical heating and cooling systems change the interior climate of a building. Moisture in the air will dissipate from the warmer area of a building the colder area and can cause serious deterioration of historic materials. Condensation can form if the dew point occurs within the building wall, particularly one that has been insulated (see a and b). Even when vapor retarders are installed (c), any non-continuous areas will provide spaces for moisture to pass. Wall Section Drawings: NPS files

Planning the New System

Climate control systems are generally classified according to the medium used to condition the temperature: air, water, or a combination of both (see overview on page 6). The complexity of choices facing a building owner or manager means that a *systematic approach* is critical in determining the most suitable system for a building, its contents, and its occupants. No matter which system is installed, a change in the interior climate will result. This physical change will in turn affect how the building materials perform. New registers, grilles, cabinets, or other accessories associated with the new mechanical system will also visually change the interior (and sometimes the exterior) appearance of the building. Regardless of the type or extent of a mechanical system, the owner of a historic building should know *before* a system is installed what it will look like and what problems can be anticipated during the life of that system. The potential harm to a building and costs to an owner of selecting the wrong mechanical system are very great.

The use of a building and its contents will largely determine the best type of mechanical system. The historic building materials and construction technology as well as the size and availability of secondary spaces within the historic structure will affect the choice of a system. It may be necessary to investigate a combination of systems. In each case, the needs of the user, the needs of the building, and the needs of a collection or equipment must be considered. It may not be necessary to have a comprehensive climate control system if climate-sensitive objects can be accommodated in special areas or climate-controlled display cases. It may not be necessary to have central air conditioning in a mild climate if natural ventilation systems can be improved through the use of operable windows, awnings, exhaust fans, and other "low-tech" means. Modern standards for climate control developed for new construction may not be achievable or desirable for historic buildings. *In each case, the lowest level of intervention needed to successfully accomplish the job should be selected.*

Before a system is chosen, the following planning steps are recommended:

1. **Determine the use of the building.** The proposed use of the building (museum, commercial, residential, retail) will influence the type of system that should be installed. The number of people and functions to be housed in a building will establish the level of comfort and service that must be provided. Avoid uses that require major modifications to significant architectural spaces. What is the intensity of use of the building: intermittent or constant use, special events or seasonal events? Will the use of the building require major new services such as restaurants, laundries, kitchens, locker rooms, or other areas that generate moisture that may exacerbate climate control within the historic space? In the context of historic preservation, uses that require radical reconfigurations of historic spaces are inappropriate for the building.

2. **Assemble a qualified team.** This team ideally should consist of a preservation architect, mechanical engineer, electrical engineer, structural engineer, and preservation consultants, each knowledgeable in codes and local requirements. If a special use (church, mu-

seum, art studio) or a collection is involved, a specialist familiar with the mechanical requirements of that building type or collection should also be hired.

Team members should be familiar with the needs of historic buildings and be able to balance complex factors: the preservation of the historic architecture (aesthetics and conservation), requirements imposed by mechanical systems (quantified heating and cooling loads), building codes (health and safety), tenant requirements (quality of comfort, ease of operation), access (maintenance and future replacement), and the overall cost to the owner.

3. **Undertake a condition assessment of the existing building and its systems.** What are the existing construction materials and mechanical systems? What condition are they in and are they reusable (see figure 6)? Where are existing chillers, boilers, air handlers, or cooling towers located? Look at the condition of all other services that may benefit from being integrated into a new system, such as electrical and fire suppression systems. Where can energy efficiency be improved to help downsize any new equipment added, and which of the historic features, e.g. shutters, awnings, skylights, can be reused (see figure 7)? Evaluate air infiltration through the exterior envelope; monitor the interior for temperature and humidity levels with hygrometers for at least a year. Identify building, site, or equipment deficiencies or the presence of asbestos that must be corrected prior to the installation or upgrading of mechanical systems.



6. A condition assessment during the planning stage would identify this round radiator in a small oval-shaped vestibule as a significant element of the historic heating system. In upgrading the mechanical system, the radiator should be retained. Photo: Michael C. Henry, P.E., AIA.

Overview of HVAC Systems

WATER SYSTEMS: Hydronic radiators, Fan coil, or radiant pipes

Water systems are generally called *hydronic* and use a network of pipes to deliver water to hot water radiators, radiant pipes set in floors or fan coil cabinets which can give both heating and cooling. Boilers produce hot water or steam; chillers produce chilled water for use with fan coil units. Thermostats control the temperature by zone for radiators and radiant floors. Fan coil units have individual controls. Radiant floors provide quiet, even heat, but are not common.

Advantages: Piped systems are generally easier to install in historic buildings because the pipes are smaller than ductwork.

Disadvantages: There is the risk, however, of hidden leaks in the wall or burst pipes in winter if boilers fail. Fan coil condensate pans can overflow if not properly maintained. Fan coils may be noisy.

Hydronic Radiators: Radiators or baseboard radiators are looped together and are usually set under windows or along perimeter walls. New boilers and circulating pumps can upgrade older systems. Most piping was cast iron although copper systems can be used if separately zoned. Modern cast iron baseboards and copper fin-tubes are available. Historic radiators can be reconditioned.

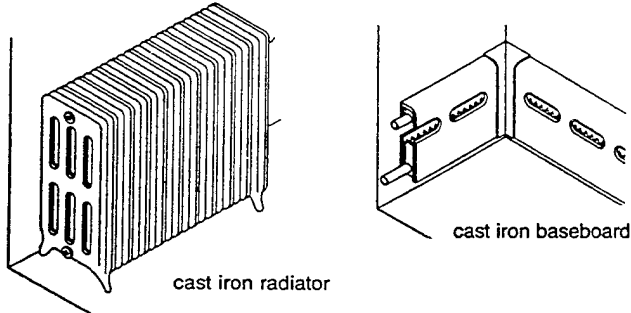

Fan Coil Units: Fan coil systems use terminal cabinets in each room serviced by 2, 3, or 4 pipes approximately 1-1/2" each in diameter. A fan blows air over the coils which are serviced by hot or chilled water. Each fan coil cabinet can be individually controlled. Four-pipe fan coils can provide both heating and cooling all year long. Most piping is steel. Non-cabinet units may be concealed in closets or custom cabinetry, such as benches, can be built.

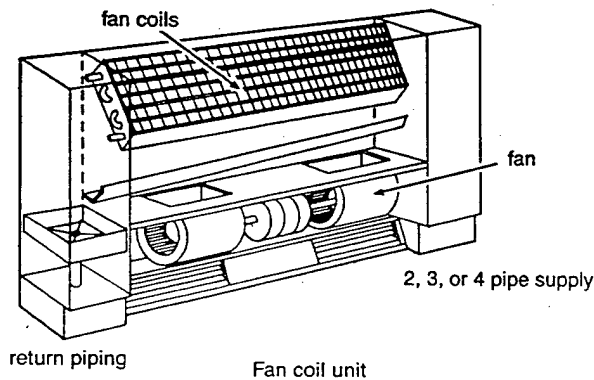

CENTRAL AIR SYSTEMS

The basic heating, ventilation and air conditioning (HVAC) system is all-air, single zone fan driven designed for low, medium or high pressure distribution. The system is composed of compressor drives, chillers, condensers, and furnace depending on whether the air is heated, chilled or both. Condensers, generally air cooled, are located outside. The ducts are sheet metal or flexible plastic and can be insulated. Fresh air can be circulated. Registers can be designed for ceilings, floors and walls. The system is controlled by thermostats; one per zone.

Advantages: Ducted systems offer a high level of control of interior temperature, humidity, and filtration. Zoned units can be relatively small and well concealed.

Disadvantages: The damage from installing a ducted system without adequate space can be serious for a historic building. Systems need constant balancing and can be noisy.

Basic HVAC: Most residential or small commercial systems will consist of a basic furnace with a cooling coil set in the unit and a refrigerant compressor or condenser located outside the building. Heating and cooling ductwork is usually shared. If sophisticated humidification and dehumidification is added to the basic HVAC system, a full climate control system results. This can often double the size of the equipment.

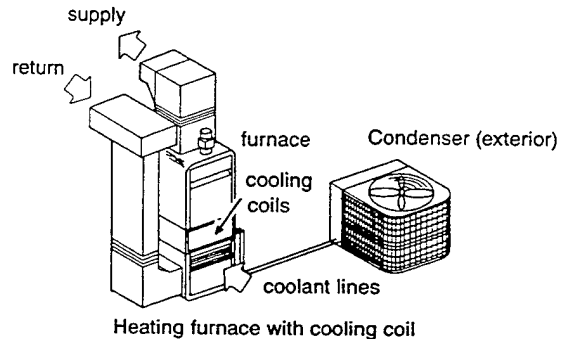

Basic Heat Pump/Air System: The heat pump is a basic HVAC system as described above except for the method of generating hot and cold air. The system operates on the basic refrigeration cycle where latent heat is extracted from the ambient air and is used to evaporate refrigerant vapor under pressure. Functions of the condenser and evaporator switch when heating is needed. Heat pumps, somewhat less efficient in cold climates, can be fitted with electric resistance coil.

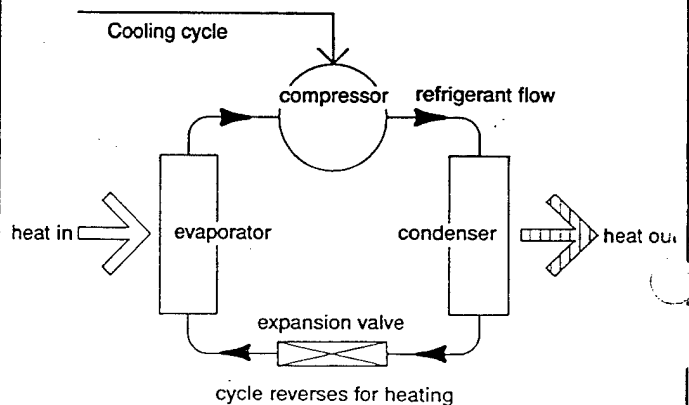

COMBINED AIR AND WATER SYSTEMS

These systems are popular for restoration work because they combine the ease of installation for the piped system with the performance and control of the ducted system. Smaller air handling units, not unlike fan coils, may be located throughout a building with service from a central boiler and chiller. In many cases the water is delivered from a central plant which services a complex of buildings.

This system overcomes the disadvantages of a central ducted system where there is not adequate horizontal or vertical runs for the ductwork. The equipment, being smaller, may also be quieter and cause less vibration. If only one air handler is being utilized for the building, it is possible to house all the equipment in a vault outside the building and send only conditioned air into the structure.

Advantages: flexibility for installation using greater piping runs with shorter ducted runs; Air handlers can fit into small spaces.
Disadvantages: piping areas may have undetected leaks; air handlers may be noisy.

Water-serviced Air Handlers:

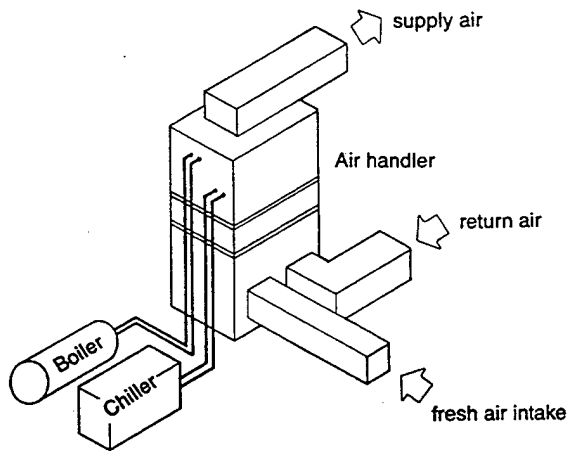

Typical Systems Layout:

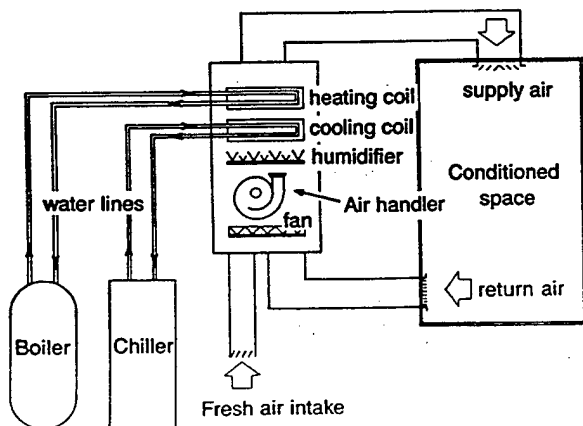

OTHER SYSTEM COMPONENTS

Non-systems components should not be overlooked if they can make a building more comfortable without causing damage to the historic resource or its collection.

Advantages: components may provide acceptable levels of comfort without the need for an entire system.

Disadvantages: Spot heating, cooling and fluxuations in humidity may harm sensitive collections or furnishings. If an integrated system is desirable, components may provide only a temporary solution.

Portable Air Conditioning:

Most individual air conditioners are set in windows or through exterior walls which can be visually as well as physically damaging to historic buildings. Newer portable air conditioners are available which sit in a room and exhaust directly to the exterior through a small slot created by a raised window sash.

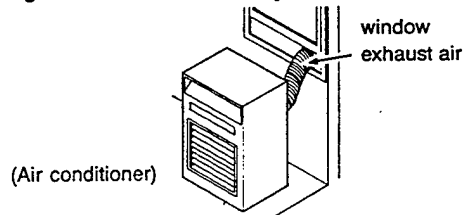

Fans: Fans should be considered in most properties to improve ventilation. Fans can be located in attics, at the top of stairs, or in individual rooms. In moderate climates, fans may eliminate the need to install central air systems.

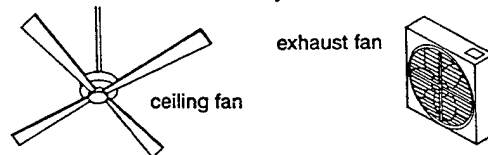

Dehumidifiers: For houses without central air handling systems, a dehumidifier can resolve problems in humid climates. Seasonal use of dehumidifiers can remove moisture from damp basements and reduce fungal growth.

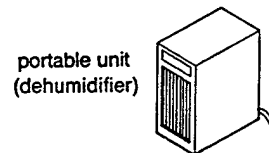

Heaters: Portable radiant heaters, such as those with water and glycol, may provide temporary heat in buildings used infrequently or during systems breakdowns. Care should be taken not to create a fire hazard with improperly wired units.

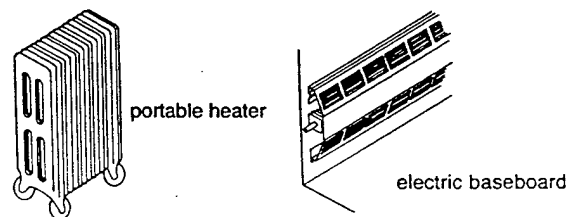

4. Prioritize architecturally significant spaces, finishes, and features to be preserved. Significant architectural spaces, finishes and features should be identified and evaluated at the outset to ensure their preservation. This includes significant existing mechanical systems or elements such as hot water radiators, decorative grilles, elaborate switchplates, and non-mechanical architectural features such as cupolas, transoms, or porches. Identify non-significant spaces where mechanical equipment can be placed and secondary spaces where equipment and distribution runs on both a horizontal and vertical basis can be located. Appropriate secondary spaces for housing equipment might include attics, basements, penthouses, mezzanines, false ceiling or floor cavities, vertical chases, stair towers, closets, or exterior below-grade vaults (see figure 8).

5. Become familiar with local building and fire codes. Owners or their representatives should meet early and often with local officials. Legal requirements should be checked; for example, can existing ductwork be reused or modified with dampers? Is asbestos abatement required? What are the energy, fire, and safety codes and standards in place, and how can they be met while maintaining the historic character of the building? How are fire separation walls and rated mechanical systems to be handled between multiple tenants? Is there a requirement for fresh air intake for stair towers that will affect the exterior appearance of the building? Many of the health, energy, and safety code requirements will influence decisions made for mechanical equipment for climate control. It is important to know what they are before the design phase begins.

6. Evaluate options for the type and size of systems. A matrix or feasibility studies should be developed to balance the benefits and drawbacks of various systems. Factors to consider include heating and/or cooling, fuel type, distribution system, control devices, generating equipment and accessories such as filtration, and humidification. What are the initial installation costs, projected fuel costs, long-term maintenance, and life-cycle

costs of these components and systems? Are parts of an existing system being reused and upgraded? The benefits of added ventilation should not be overlooked (see figure 9). What are the trade-offs between one large central system and multiple smaller systems? Should there be a forced air ducted system, a 2-pipe fan coil system, or a combined water and air system? What space is available for the equipment and distribution system? Assess the fire-risk levels of various fuels. Understand the advantages and disadvantages of the various types of mechanical systems available. Then evaluate each of these systems in light of the preservation objectives established during the design phase of planning.

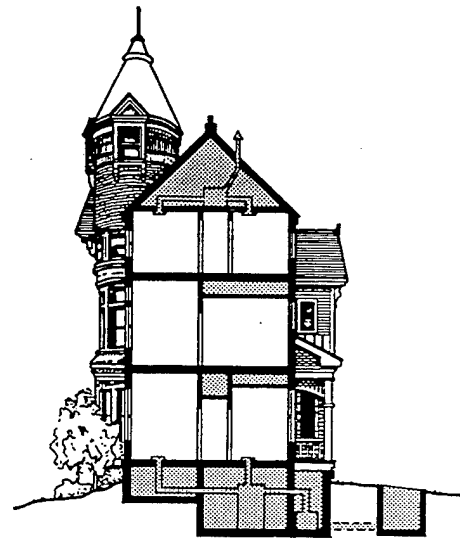

8. In considering options for new systems, existing spaces should be evaluated for their ability to house new equipment. This sketch shows several areas where new mechanical equipment could be located to avoid damaging significant spaces. Sketch: NPS files

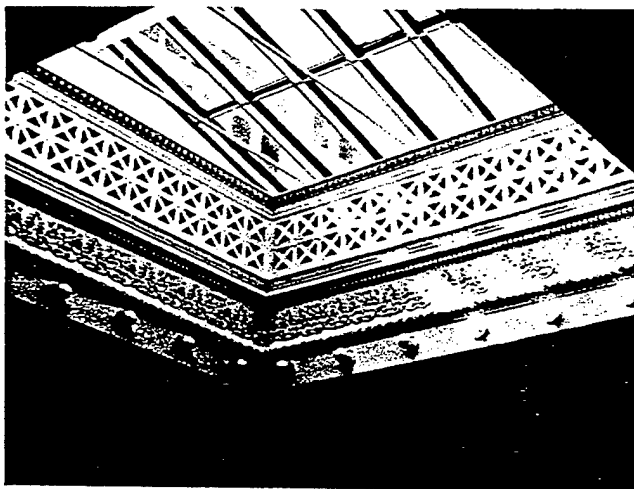

7. Operable skylights and grilles that can be adapted for return air should be identified as part of the planning phase for new or upgraded mechanical systems. Photo: Dianne Pierce, NPS files.



9. Improving ventilation through traditional means should not be overlooked in planning new or upgraded HVAC systems. In mild climates, good exhaust fans can often eliminate the need for air conditioning or can reduce equipment size by reducing cooling loads. Photo: Ernest A. Conrad, P.E.

Designing the new system

In designing a system, it is important to anticipate how it will be installed, how damage to historic materials can be minimized, and how visible the new mechanical system will be within the restored or rehabilitated spaces (see figure 10 a-f). Mechanical equipment space needs are often overwhelming; in some cases, it may be advantageous to look for locations outside of the building, including ground vaults, to house some of the equipment but only if there is no adverse impact to the historic landscape or adjacent archeological resources. Various means for reducing the heating and cooling loads (and thereby the size of the equipment) should be investigated. This might mean reducing slightly the comfort levels of the interior, increasing the number of climate control zones, or improving the energy efficiency of the building.

The following activities are suggested during the design phase of the new system:

1. Establish specific criteria for the new or upgraded mechanical system. New systems should be *installed with a minimum of damage* to the resource and should be *visually compatible with the architecture* of the building. They should be installed in a way that is *easy to service, maintain, and upgrade* in the future. There should be *safety and back-up monitors in place* if buildings have collections, computer rooms, storage vaults or special conditions that need monitoring. The new systems should work within the structural limits of the historic building. They should produce *no undue vibration, no undue noise, no dust or mold, and no excess moisture* that could damage the historic building materials. If any equipment is to be located outside of the building, there should be *no impact to the historic appearance of building or site*, and there should be *no impact on archeological resources*.

2. Prioritize the requirements for the new climate control system. The use of the building will determine the level of interior comfort and climate control. Sometimes, various temperature zones may safely be created within a historic building. This zoned approach may be appropriate for buildings with specialized collections storage, for buildings with mixed uses, or for large buildings with different external exposures, occupancy patterns, and delivery schedules for controlled air. Special archives, storage vaults or computer rooms may need a completely different climate control from the rest of the building. Determine temperature and humidity levels for occupants and collections and ventilation requirements between differing zones. Establish if the system is to run 24 hours a day or only during operating or business hours. Determine what controls are optimum (manual, computer, preset automatic, or other). The size and location of the equipment to handle these different situations will ultimately affect the design of the overall system as well.

3. Minimize the impact of the new HVAC on the existing architecture. Design criteria for the new system should be based on the type of architecture of the historic resource. Consideration should be given as to whether or not the delivery system is visible or hidden. Utilitarian and industrial spaces may be capable of

accepting a more visible and functional system. More formal, ornate spaces which may be part of an interpretive program may require a less visible or disguised system. A ducted system should be installed without ripping into or boxing out large sections of floors, walls, or ceilings. A wet pipe system should be installed so that hidden leaks will not damage important decorative finishes. In each case, not only the type of system (air, water, combination), but its distribution (duct, pipe) and delivery appearance (grilles, cabinets, or registers) must be evaluated. It may be necessary to use a combination of different systems in order to preserve the historic building. Existing chases should be reused whenever possible.

4. Balance quantitative requirements and preservation objectives. The ideal system may not be achievable for each historic resource due to cost, space limitations, code requirements, or other factors beyond the owner's control. However, significant historic spaces, finishes, and features can be preserved in almost every case, even given these limitations. For example, if some ceiling areas must be slightly lowered to accommodate ductwork or piping, these should be in secondary areas away from decorative ceilings or tall windows. If modern fan coil terminal units are to be visible in historic spaces, consideration should be given to custom designing the cabinets or to using smaller units in more locations to diminish their impact. If grilles and registers are to be located in significant spaces, they should be designed to work within the geometry or placement of decorative elements. All new elements, such as ducts, registers, pipe-runs, and mechanical equipment should be installed in a reversible manner to be removed in the future without further damage to the building (see fig 11).

Systems Performance and Maintenance

Once the system is installed, it will require routine maintenance and balancing to ensure that the proper performance levels are achieved. In some cases, extremely sophisticated, computerized systems have been developed to control interior climates, but these still need monitoring by trained staff. If collection exhibits and archival storage are important to the resource, the climate control system will require constant monitoring and tuning. Back-up systems are also needed to prevent damage when the main system is not working. The owner, manager, or chief of maintenance should be aware of all aspects of the new climate control system and have a plan of action before it is installed.

Regular training sessions on operating, monitoring, and maintaining the new system should be held for both curatorial and building maintenance staff. If there are curatorial reasons to maintain constant temperature or humidity levels, only individuals thoroughly trained in how the HVAC systems operates should be able to adjust thermostats. Ill-informed and haphazard attempts to adjust comfort levels, or to save energy over weekends and holidays, can cause great damage.

10. The following photographs illustrate recent preservation projects where careful planning and design retained the historic character of the resources.



before

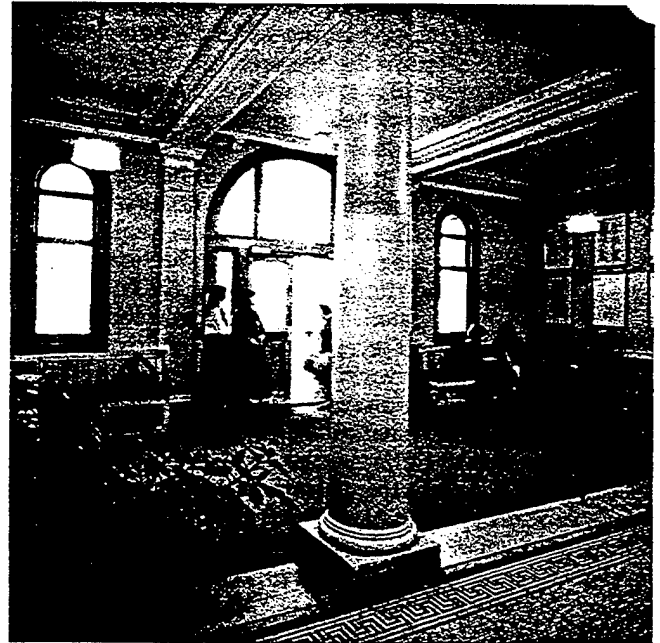

after

a. Before and after of a circa 1900 school entrance. The radiators have been replaced with a two-pipe fan coil system built into bench seats. The ceiling was preserved and no exposed elements were required to add air conditioning. Piping runs are under the benches and there was no damage to the masonry walls. Photos: Notter Finegold + Alexander Inc. and Lautman Photography, Washington.

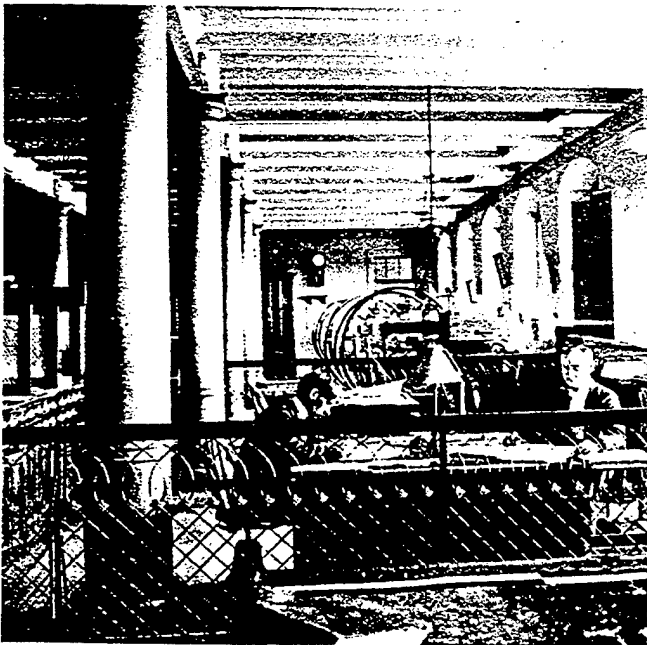

historic



after

d. Auditors Buildings, Washington, D.C. This upper floor workspace had been modified over the years with dropped ceilings and partitions. In the recent restoration, the open plan workspace was restored, the false ceiling was removed, and the fireproof construction was exposed. A variable air volume (VAV) system using round double shell exposed ductwork is in keeping with the industrial character of the architectural spa. Photo: Kenneth Wyner Photography, courtesy of Notter Finegold + Alexander Inc. Before view provided by Notter Finegold + Alexander/Maria.



b. Central air conditioning was installed in the corridors of this circa 1900 school building by adding an air handler over the entrance from a vestibule. The custom-designed slot registers provide linear diffusers without detracting from the architecture of the space. Photo: Lautman Photography courtesy of Notter Finegold + Alexander Inc.

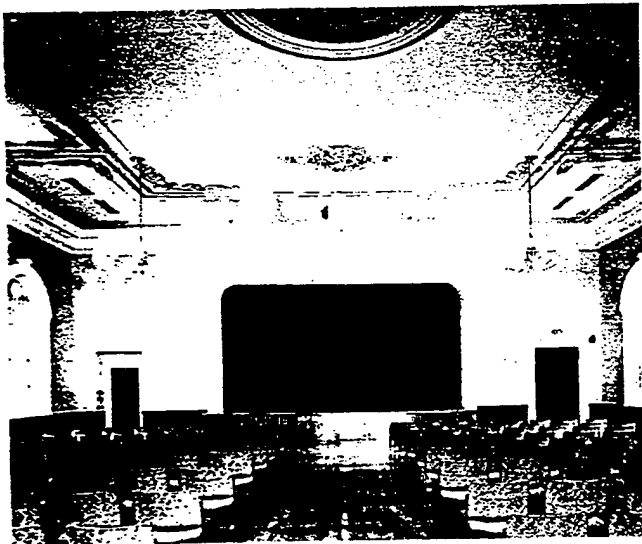

e. Town Hall, Andover, MA. The upstairs auditorium was restored and new mechanical systems were installed. Perimeter baseboard radiation provides heat and air handlers, located in the attic space provide air conditioning. The cast iron ceiling grille was adapted for return air and the supply registers were installed in a symmetrical and regular manner to minimize impact on the historic ceiling. Photo: David Hewitt/Anne Garrison for Ann Beha Associates.



c. Conference room, Auditors Building, Washington, D.C. The historic steam radiators were retained for heating. The cast iron ceiling register was retained as a decorative element, but made inoperable to meet fire codes. Photo: Kenneth Wyner Photography courtesy of Notter Finegold + Alexander Inc.

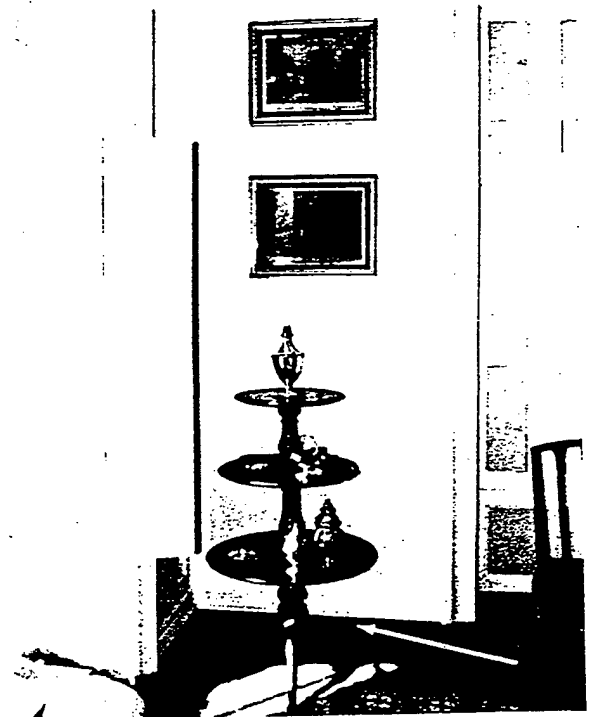

f. Homewood, Baltimore, MD. This elegant circa 1806 residence is now a house museum. The registers for the forced air ducted system seen behind the table legs, are grained to blend with the historic baseboards. The HVAC system uses a water/air system where chilled water and steam heat are converted to conditioned air. Photo: Courtesy Homewood Museum, Johns Hopkins University.

HVAC Do's and Don'ts

DO's:

- Use shutters, operable windows, porches, curtains, awnings, shade trees and other historically appropriate non-mechanical features of historic buildings to reduce the heating and cooling loads. Consider adding sensitively designed storm windows to existing historic windows.
- Retain or upgrade existing mechanical systems whenever possible: for example, reuse radiator systems with new boilers, upgrade ventilation within the building, install proper thermostats or humidistats.
- Improve energy efficiency of existing buildings by installing insulation in attics and basements. Add insulation and vapor barriers to exterior walls *only* when it can be done without further damage to the resource.
- In major spaces, retain decorative elements of the historic system whenever possible. This includes switchplates, grilles and radiators. Be creative in adapting these features to work within the new or upgraded system.
- Use space in existing chases, closets or shafts for new distribution systems.
- Design climate control systems that are compatible with the architecture of the building: hidden system for formal spaces, more exposed systems possible in industrial or secondary spaces. In formal areas, avoid standard commercial registers and use custom slot registers or other less intrusive grilles.
- Size the system to work within the physical constraints of the building. Use multi-zoned smaller units in conjunction with existing vertical shafts, such as stacked closets, or consider locating equipment in vaults underground, if possible.
- Provide adequate ventilation to the mechanical rooms as well as to the entire building. Selectively install air intake grilles in less visible basement, attic, or rear areas.
- Maintain appropriate temperature and humidity levels to meet requirements without accelerating the deterioration of the historic building materials. Set up regular monitoring schedules.
- Design the system for maintenance access and for future systems replacement.
- For highly significant buildings, install safety monitors and backup features, such as double pans, moisture detectors, lined chases, and battery packs to avoid or detect leaks and other damage from system failures.

- Have a regular maintenance program to extend equipment life and to ensure proper performance.
- Train staff to monitor the operation of equipment and to act knowledgeably in emergencies or breakdowns.
- Have an emergency plan for both the building and any curatorial collections in case of serious malfunctions or breakdowns.

DON'TS:

- Don't install a new system if you don't need it.
- Don't switch to a new type of system (e.g. forced air) unless there is sufficient space for the new system or an appropriate place to put it.
- Don't over-design a new system. Don't add air conditioning or climate control if they are not absolutely necessary.
- Don't cut exterior historic building walls to add through-wall heating and air conditioning units. These are visually disfiguring, they destroy historic fabric, and condensation runoff from such units can further damage historic materials.
- Don't damage historic finishes, mask historic features, or alter historic spaces when installing new systems.
- Don't drop ceilings or bulkheads across window openings.
- Don't remove repairable historic windows or replace them with inappropriately designed thermal windows.
- Don't seal operable windows, unless part of a museum where air pollutants and dust are being controlled.
- Don't place condensers, solar panels, chimney stacks, vents or other equipment on visible portions of roofs or at significant locations on the site.
- Don't overload the building structure with the weight of new equipment, particularly in the attic.
- Don't place stress on historic building materials through the vibrations of the new equipment.
- Don't allow condensation on windows or within walls to rot or spall adjacent historic building materials.

Maintenance staff should learn how to operate, monitor, and maintain the mechanical equipment. They must know where the maintenance manuals are kept. Routine maintenance schedules must be developed for changing and cleaning filters, vents, and condensate pans to control fungus, mold, and other organisms that are dangerous to health. Such growths can harm both inhabitants and equipment. (In piped systems, for example, molds in condensate pans can block drainage lines and cause an overflow to leak onto finished surfaces). Maintenance staff should also be able to monitor the appropriate gauges, dials, and thermographs. Staff must be trained to intervene in emergencies, to know where the master controls are, and whom to call in an emergency. As new personnel are hired, they will also require maintenance training.

In addition to regular cyclical maintenance, thorough inspections should be undertaken from time to time to evaluate the continued performance of the climate control system. As the system ages, parts are likely to fail, and signs of trouble may appear. Inadequately ventilated areas may smell musty. Wall surfaces may show staining, wet patches, bubbling or other signs of moisture damage. Routine tests for air quality, humidity, and temperature should indicate if the system is performing properly. If there is damage as a result of the new system, it should be repaired immediately and then closely monitored to ensure complete repair.

Equipment must be accessible for maintenance and should be visible for easy inspection. Moreover, since mechanical systems last only 15-30 years, the system itself must be "reversible." That is, the system must be installed in such a way that later removal will not damage the building. In addition to servicing, the back-up monitors that signal malfunctioning equipment must be routinely checked, adjusted, and maintained. Checklists should be developed to ensure that all aspects of routine maintenance are completed and that data is reported to the building manager.

Conclusion

The successful integration of new systems in historic buildings can be challenging. Meeting modern HVAC requirements for human comfort or installing controlled climates for museum collections or for the operation of complex computer equipment can result in both visual and physical damage to historic resources. Owners of historic buildings must be aware that the final result will involve balancing multiple needs; no perfect heating, ventilating, and air conditioning system exists. In undertaking changes to historic buildings, it is best to have the advice and input of trained professionals who can:

- assess the condition of the historic building,
- evaluate the significant elements that should be preserved or reused,
- prioritize the preservation objectives,
- understand the impact of new interior climate conditions on historic materials,
- integrate preservation with mechanical and code requirements,
- maximize the advantages of various new or upgraded mechanical systems,
- understand the visual and physical impact of various installations,
- identify maintenance and monitoring requirements for new or upgraded systems, and
- plan for the future removal or replacement of the system.

Too often the presumed climate needs of the occupants or collections can be detrimental to the long-term preservation of the building. With a careful balance between the preservation needs of the building and the interior temperature and humidity needs of the occupants, a successful project can result.



a



b

11. During the restoration of this 1806 National Historic Landmark (photo a), a new climate control system was installed. The architects removed all the earlier mechanical equipment from the house and installed new equipment in a 30' x 40' concrete vault located underground 150 feet from the house itself (photo b). Only conditioned air is blown into the house reusing much of the circa 1930s ductwork. Photos: Thomas C. Jester.

Bibliography

- Banham, Reyner. *The Architecture of the Well-Tempered Environment*. London: The Architectural Press, 1969.
- Burns, John A., AIA. *Energy Conserving Features Inherent in Older Homes*. Washington: U.S. Department of Housing and Urban Development and U.S. Department of the Interior, 1982.
- Cowan, Henry J. *Science and Building: Structural and Environmental Design in the Nineteenth and Twentieth Centuries*. New York: John Wiley & Sons, 1978.
- Ferguson, Eugene S. "An Historical Sketch of Central Heating: 1800-1860," in *Building Early America* (Charles Peterson, editor) Philadelphia: Chilton Book Co., 1976.
- Fitch, James Marston. *American Building: The Environmental Forces That Shape It*. Boston: Houghton Mifflin Co., 1972.
- Giedion, Siegfried. *Mechanization Takes Command; a Contribution to Anonymous History*. New York: Oxford University Press, 1948.
- Merritt, Frederick S. *Building Engineering and Systems Design*. New York: Van Nostrand Reinhold Co, 1979.
- Smith, Baird M. *Preservation Briefs 3: Conserving Energy in Historic Buildings*. Washington, DC: U.S. Department of the Interior, 1978.
- Turberg, Edward. *A History of American Building Technology*. Durham: Durham Technical Institute, 1981.

Acknowledgements

The author gratefully acknowledges the invaluable assistance of Michael C. Henry, P.E., AIA, in the development and technical editing of this Preservation Brief. Technical review was also provided by Ernest A. Conrad, P.E. Thanks is also given to staff members of the National Park Service Cultural Resources Programs, including Tom Keohan and Catherine Colby, Rocky Mountain Region; Michael Crowe, Western Region; Mark Chavez, Midwest Region; Randall J. Biallas, AIA, Chief, Park Historic Architecture Division, and George A. Thorsen, Historical Architect, Denver Service Center. Special thanks is also given to Michael J. Auer of Technical Preservation Services for his editorial assistance in preparing this paper and Tim Buehner for his assistance with the illustrations.

This publication has been prepared pursuant to the National Historic Preservation Act of 1966, as amended, which directs the Secretary of the Interior to develop and make available information concerning historic properties. Preservation Brief 24 was developed under the editorship of H. Ward Jandl, Chief, Technical Preservation Services. Comments on the usefulness of this publication may be directed to Chief, Technical Preservation Services Branch, Preservation Assistance Division, National Park Service, P.O. Box 37127, Washington, D.C. 20013-7127. This publication is not copyrighted and can be reproduced without penalty. Normal procedures for credit to the author and the National Park Service are appreciated.

32 PRESERVATION BRIEFS

Making Historic Properties Accessible

Thomas C. Jester and Sharon C. Park, AIA



U.S. Department of the Interior
National Park Service
Cultural Resources
Preservation Assistance

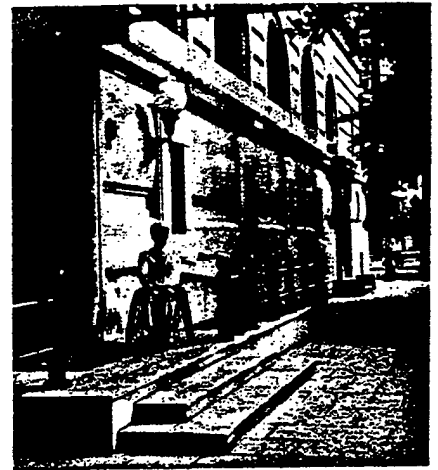

Historically, most buildings and landscapes were not designed to be readily accessible for people with disabilities. In recent years, however, emphasis has been placed on preserving historically significant properties, and on making these properties—and the activities within them—more accessible to people with disabilities. With the passage of the Americans with Disabilities Act in 1990, access to properties open to the public is now a civil right.

This Preservation Brief introduces the complex issue of providing accessibility at historic properties, and underscores the need to balance accessibility and historic preservation. It provides guidance on making historic properties accessible while preserving their historic character; the Brief also provides examples to show that independent physical accessibility at historic properties can be achieved with careful planning, consultation, and sensitive design. While the Brief focuses primarily on making buildings and their sites accessible, it also includes a section on historic landscapes. The Brief will assist historic property owners, design professionals, and administrators in evaluating their historic properties so that the highest level of accessibility can be provided while minimizing changes to historic materials and features. Because many projects encompassing accessibility work are complex, it is advisable to consult with experts in the fields of historic preservation and accessibility before proceeding with permanent physical changes to historic properties.

Modifications to historic properties to increase accessibility may be as simple as a small, inexpensive ramp to overcome one entrance step, or may involve changes to exterior and interior features. The Brief does not provide a detailed explanation of local or State accessibility laws as they vary from jurisdiction to jurisdiction. A concise explanation of several federal accessibility laws is included on page 13.

Planning Accessibility Modifications

Historic properties are distinguished by features, materials, spaces, and spatial relationships that contribute to their historic character. Often these elements, such as steep terrain, monumental steps, narrow or heavy doors,

decorative ornamental hardware, and narrow pathways and corridors, pose barriers to persons with disabilities, particularly to wheelchair users (See Figure 1).

A three-step approach is recommended to identify and implement accessibility modifications that will protect the integrity and historic character of historic properties:

- 1) Review the historical significance of the property and identify character-defining features;
- 2) Assess the property's existing and required level of accessibility; and
- 3) Evaluate accessibility options within a preservation context.

1) Review the Historical Significance of the Property

If the property has been designated as historic (properties that are listed in, or eligible for listing in the National Register of Historic Places, or designated under State or local law), the property's nomination file should be reviewed to learn about its significance. Local preservation commissions and State Historic Preservation Offices can usually provide



Figure 1. It is important to identify the materials, features, and spaces that should be preserved when planning accessibility modifications. These may include stairs, railings, doors, and door surrounds. Photo: National Park Service files.

copies of the nomination file and are also resources for additional information and assistance. Review of the written documentation should always be supplemented with a physical investigation to identify which character-defining features and spaces must be protected whenever any changes are anticipated. If the level of documentation for a property's significance is limited, it may be necessary to have a preservation professional identify specific historic features, materials, and spaces that should be protected.

For most historic properties, the construction materials, the form and style of the property, the principal elevations, the major architectural or landscape features, and the principal public spaces constitute some of the elements that should be preserved. Every effort should be made to minimize damage to the materials and features that convey a property's historical significance when making modifications for accessibility. Very small or highly significant properties that have never been altered may be extremely difficult to modify.

Secondary spaces and finishes and features that may be less important to the historic character should also be identified; these may generally be altered without jeopardizing the historical significance of a property. Non-significant spaces, secondary pathways, later additions, previously altered areas, utilitarian spaces, and service areas can usually be modified without threatening or destroying a property's historical significance.

2) Assess the Property's Existing and Required Level of Accessibility

A building survey or assessment will provide a thorough evaluation of a property's accessibility. Most surveys identify accessibility barriers in the following areas: building and site entrances; surface textures, widths and slopes of walkways; parking; grade changes; size, weight and configuration of doorways; interior corridors and path of travel restrictions; elevators; and public toilets and amenities (See Figure 2). Simple audits can be completed by property owners using readily available checklists (See Further Reading). Accessibility specialists can be hired to assess barriers in more complex properties, especially those with multiple buildings, steep terrain, or interpretive programs. Persons with disabilities can be particularly helpful in assessing specific barriers.

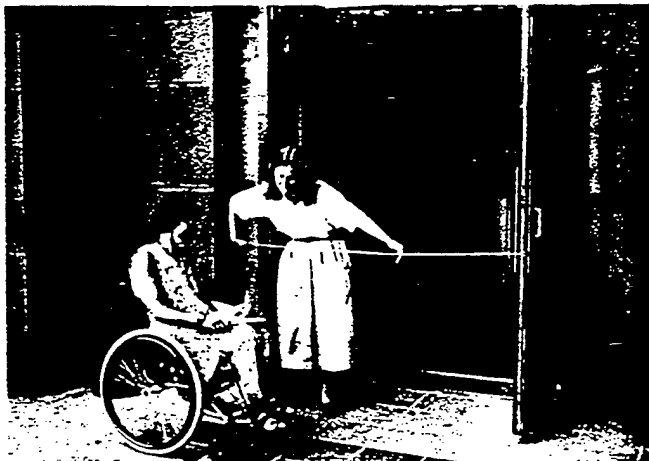

Figure 2. Surveys of historic properties can identify accessibility barriers. Persons with disabilities and accessibility consultants should participate whenever possible. Photo: Thomas Jester.

All applicable accessibility requirements—local codes, State codes and federal laws—should be reviewed carefully before undertaking any accessibility modification. Since many States and localities have their own accessibility regulations and codes (each with their own requirements for dimensions and technical requirements), owners should use the most stringent accessibility requirements when implementing modifications. The Americans with Disability Act Accessibility Guidelines (ADAAG) is the document that should be consulted when complying with the Americans with Disabilities Act (ADA) requirements.

3) Identify and Evaluate Accessibility Options within a Preservation Context

Once a property's significant materials and features have been identified, and existing and required levels of accessibility have been established, solutions can be developed (See Figure 3). Solutions should provide the greatest amount of accessibility without threatening or destroying those materials and features that make a property significant. Modifications may usually be phased over time as funds are available, and interim solutions can be considered until more permanent solutions are implemented. A team comprised of persons with disabilities, accessibility and historic preservation professionals, and building inspectors should be consulted as accessibility solutions are developed.

Modifications to improve accessibility should generally be based on the following priorities:

- 1) Making the main or a prominent public entrance and primary public spaces accessible, including a path to the entrance;
- 2) Providing access to goods, services, and programs;
- 3) Providing accessible restroom facilities; and,
- 4) Creating access to amenities and secondary spaces.

All proposed changes should be evaluated for conformance with the Secretary of the Interior's "Standards for the Treatment of Historic Properties," which were created for property owners to guide preservation work. These Standards stress the importance of retaining and protecting the materials and features that convey a property's historical significance. Thus, when new features are incorporated for accessibility, historic materials and features should be retained whenever possible.

Accessibility modifications should be in scale with the historic property, visually compatible, and, whenever possible, reversible. Reversible means that if the new feature were removed at a later date, the essential form and integrity of the property would be unimpaired. The design of new features should also be differentiated from the design of the historic property so that the evolution of the property is evident. See Making Historic Buildings Accessible on page 9.

In general, when historic properties are altered, they should be made as accessible as possible. However, if an owner or a project team believes that certain modifications would threaten or destroy the significance of the property, the State Historic Preservation Officer should be consulted to determine whether or not any special accessibility provisions may be used. Special accessibility provisions for historic properties will vary depending on the applicable accessibility requirements.



A.



B.



C.

Figure 3. Before implementing accessibility modifications, owners should consider the potential effect on their historic property. At the Derby House in Salem, Massachusetts, several solutions to make the entrance accessible were considered, including regrading (a); a lift (b); and a ramp (c). The solution, an entrance on a secondary elevation, preserves the building's architectural significance and is convenient to designated parking. Drawings: National Park Service Files..

In some cases, programmatic access may be the only option for extremely small or unaltered historic properties, such as a two-story house museum with no internal elevator. Programmatic access for historic properties refers to alternative methods of providing services, information, and experiences when physical access cannot be provided. It

may mean offering an audio-visual program showing an inaccessible upper floor of a historic house museum, providing interpretive panels from a vista at an inaccessible terraced garden, or creating a tactile model of a historic monument for people with visual impairments.

Accessibility Solutions

The goal in selecting appropriate solutions for specific historic properties is to provide a high level of accessibility without compromising significant features or the overall character of the property. The following sections describe accessibility solutions and offer guidance on specific historic property components, namely the building site, entrances, interiors, landscapes, amenities, and new additions. Several solutions are discussed in each section, referencing dimensions and technical requirements from the ADA's accessibility guidelines, ADAAG. State and local requirements, however, may differ from the ADA requirements. Before making any modification owners should be aware of all applicable accessibility requirements.

The Building Site

An accessible route from a parking lot, sidewalk, and public street to the entrance of a historic building or facility is essential. An accessible route, to the maximum extent possible, should be the circulation route used by the general public. Critical elements of accessible routes are their widths, slopes, cross slopes, and surface texture. Each of these route elements must be appropriately designed so that the route can be used by everyone, including people with disabilities. The distance between the arrival and destination points should also be as short as possible. Sites containing designed landscapes should be carefully evaluated before making accessibility modifications. Historic landscapes are described in greater detail on pages 10 and 11.

Providing Convenient Parking. If parking is provided, it should be as convenient as possible for people with disabilities. Specially designated parking can often be created to improve accessibility (See Figure 4). Modifications to parking configurations and pathways should not alter significant landscape features.

Creating an Accessible Route. The route or path through a site to a historic building's entrance should be wide enough, generally at least 3 feet (91 cm), to accommodate visitors



Figure 4. Parking designated for people with disabilities is provided near an accessible entrance to the Springfield Library in Springfield, Massachusetts. Photo: William Smith.

with disabilities and must be appropriately graded with a stable, firm, and slip-resistant surface. Existing paths should be modified to meet these requirements whenever possible as long as doing so would not threaten or destroy significant materials and features.

Existing surfaces can often be stabilized by providing a new base and resetting the paving materials, or by modifying the path surface. In some situations it may be appropriate to create a new path through an inaccessible area. At large properties, it may be possible to regrade a slope to less than 1:20 (5%), or to introduce one or more carefully planned ramps. Clear directional signs should mark the path from arrival to destination.

Entrances

Whenever possible, access to historic buildings should be through a primary public entrance. In historic buildings, if this cannot be achieved without permanent damage to character-defining features, at least one entrance used by the public should be made accessible. If the accessible entrance is not the primary public entrance, directional signs should direct visitors to the accessible entrance (See Figure 5). A rear or service entrance should be avoided as the only mean of entering a building.

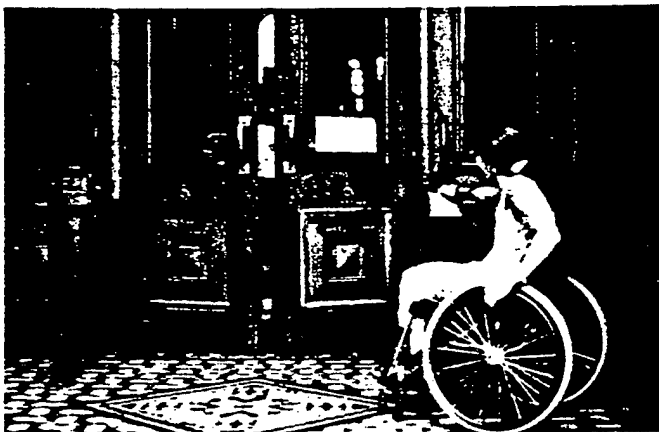

Figure 5. A universal access symbol clearly marks the Arts and Industries Building in Washington, D.C., and a push plate (right) engages the automatic door-opener. Photo: Thomas Jester.

Creating an accessible entrance usually involves overcoming a change in elevation. Steps, landings, doors, and thresholds, all part of the entrance, often pose barriers for persons with disabilities. To preserve the integrity of these features, a number of solutions are available to increase accessibility. Typical solutions include regrading, incorporating ramps, installing wheelchair lifts, creating new entrances, and modifying doors, hardware, and thresholds.

Regrading an Entrance. In some cases, when the entrance steps and landscape features are not highly significant, it may be possible to regrade to provide a smooth entrance into a building. If the existing steps are historic masonry, they should be buried, whenever possible, and not removed (See Figure 6).

Incorporating Ramps. Permanent ramps are perhaps the most common means to make an entrance accessible. As a new feature, ramps should be carefully designed and appropriately located to preserve a property's historic character (See Figure 7). Ramps should be located at public

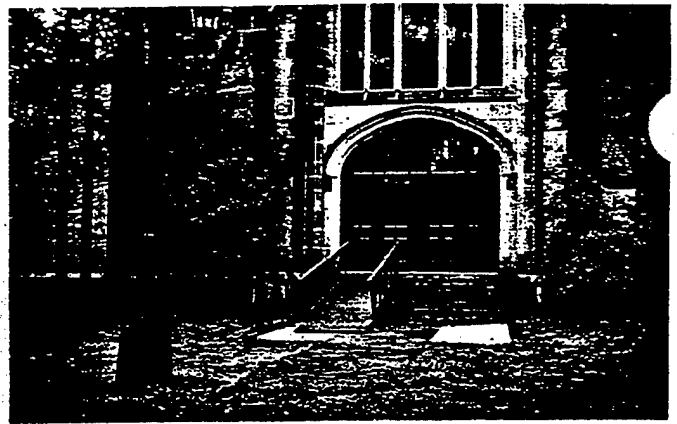

Figure 6. Entrances can be regraded to make a building accessible as long as no significant landscape features will be destroyed and as long as the building's historic character is preserved. The Houghton Chapel (a) in Wellesley, Massachusetts, was made accessible by regrading over the historic steps (b). Photos: Carol R. Johnson & Associates.



Figure 7. This ramp is convenient for visitors with disabilities and preserves the building's historic character. The design is also compatible in scale with the building. Photo: William Smith.

entrances used by everyone whenever possible, preferably where there is minimal change in grade. Ramps should also be located to minimize the loss of historic features at the connection points—porch railings, steps, and windows—and should preserve the overall historic setting and character of the property. Larger buildings may have below grade areas that can accommodate a ramp down to an entrance (See Figure 8). Below grade entrances can be considered if the ramp leads to a publicly used interior, such as an auditorium, or if the building is serviced by a public elevator. Ramps can often be incorporated behind



Figure 8. A new below-grade ramp provides access to Lake MacDonald Lodge in Glacier National Park. Photo: Thomas Jester

historic features, such as cheek-walls or railings, to minimize the visual effect (See Figure 9).

The steepest allowable slope for a ramp is usually 1:12 (8%), but gentler slopes should be used whenever possible to accommodate people with limited strength. Greater changes in elevation require larger and longer ramps to meet accessibility scoping provisions and may require an intermediate landing. Most codes allow a slightly steeper ramp for historic buildings to overcome one step.

Ramps can be faced with a variety of materials, including wood, brick, and stone. Often the type and quality of the materials determines how compatible a ramp design will be with a historic property (See Figure 10). Unpainted pressure-treated wood should not be used to construct ramps because it usually appears temporary and is not visually compatible with most historic properties. Railings



Figure 9. This ramp was created by infilling the window-well and slightly modifying the historic railing. The ramp preserves this building's historic character. Photo: Thomas Jester.



Figure 10. This brick ramp provides access to St. Anne's Episcopal Church in Annapolis, Maryland. Its design is compatible with the historic building. Photo: Charity V. Davidson.

should be simple in design, distinguishable from other historic features, and should extend one foot beyond the sloped area (See Figure 11).

Ramp landings must be large enough for wheelchair users, usually at least 5 feet by 5 feet (152.5 cm by 152.5 cm), and the top landing must be at the level of the door threshold. It may be possible to reset steps by creating a ramp to accommodate minor level changes and to meet the threshold without significantly altering a property's historic character. If a building's existing landing is not wide or deep enough to accommodate a ramp, it may be



Figure 11. Simple, contemporary railings that extend beyond the ramp slope make this ramp compatible with the industrial character of this building. Photo: Thomas Jester.

necessary to modify the entry to create a wider landing. Long ramps, such as switchbacks, require intermediate landings, and all ramps should be detailed with an appropriate edge and railing for wheelchair users and visually impaired individuals.

Temporary or portable ramps are usually constructed of light-weight materials and, thus, are rarely safe or visually compatible with historic properties. Moreover, portable ramps are often stored until needed and, therefore, do not meet accessibility requirements for independent access. Temporary and portable ramps, however, may be an acceptable interim solution to improve accessibility until a permanent solution can be implemented (See Figure 12).



Figure 12. The Smithsonian Institution installed a temporary ramp on its visitor's center to allow adequate time to design an appropriate permanent ramp. Photo: Thomas Jester.

Installing Wheelchair Lifts. Platform lifts and inclined stair lifts, both of which accommodate only one person, can be used to overcome changes of elevation ranging from three to 10 feet (9 m-3 m) in height. However, many States have restrictions on the use of wheelchair lifts, so all applicable codes should be reviewed carefully before installing one. Inclined stair lifts, which carry a wheelchair on a platform up a flight of stairs, may be employed selectively.

They tend to be visually intrusive, although they are relatively reversible. Platform lifts can be used when there is inadequate space for a ramp. However, such lifts should be installed in unobtrusive locations and under cover to minimize maintenance if at all possible (See Figure 13). A similar, but more expensive platform lift has a retracting railing that lowers into the ground, minimizing the visual effect to historic properties (See Figure 14). Mechanical lifts have drawbacks at historic properties with high public visitation because their capacity is limited, they sometimes cannot be operated independently, and they require frequent maintenance.

Considering a New Entrance. When it is not possible to modify an existing entrance, it may be possible to develop a new entrance by creating an entirely new opening in an appropriate location, or by using a secondary window for an opening. This solution should only be considered after exhausting all possibilities for modifying existing entrances (See Figure 15).

Retrofitting Doors. Historic doors generally should not be replaced, nor should door frames on the primary elevation be widened, as this may alter an important feature of a historic design. However, if a building's historic doors have been removed, there may be greater latitude in designing a compatible new entrance. Most accessibility standards require at least a 32" (82 cm) clear opening with manageable door opening pressures. The most desirable preservation solution to improve accessibility is retaining historic doors and upgrading the door pressure with one of several devices. Automatic door openers



Figure 13. Platform lifts like the one used on this building require minimal space and can be removed without damaging historic materials. Shielded with lattice work, this lift is also protected by the roof eaves. Approach path should be stable, firm, and slip resistant. Photo: Sharon Park.

Readily Achievable Accessibility Modifications



Many accessibility solutions can be implemented easily and inexpensively without destroying the significance of historic properties. While it may not be possible to undertake all of the modifications listed below, each change will improve accessibility.

Sites and Entrances

- Creating a designated parking space.
- Installing ramps.
- Making curb cuts.

Interiors

- Repositioning shelves.
- Rearranging tables, displays, and furniture.
- Repositioning telephones.
- Adding raised markings on elevator control buttons.
- Installing flashing alarm lights.
- Installing offset hinges to widen doorways.
- Installing or adding accessible door hardware.
- Adding an accessible water fountain, or providing a paper cup dispenser at an inaccessible water fountain.

Restrooms

- Installing grab bars in toilet stalls.
- Rearranging toilet partitions to increase maneuvering space.
- Insulating lavatory pipes under sinks to prevent burns.
- Installing a higher toilet seat.
- Installing a full-length bathroom mirror.
- Repositioning the paper towel dispenser.



Figure 14. At the Lieutenant Governor's Mansion in Frankfort, Kentucky, a retracting lift (b) was installed to minimize the visual effect on this historic building when not in use (a). Photos: Aging Technology Incorporated.



Figure 15. A new entrance to the elevator lobby replaces a window at Faneuil Hall in Boston, Massachusetts. The new entrance is appropriately differentiated from the historic design. Photo: Paul Holtz.



(operated by push buttons, mats, or electronic eyes) and power-assisted door openers can eliminate or reduce door pressures that are accessibility barriers, and make single or double-leaf doors fully operational (See Figure 16).

Adapting Door Hardware. If a door opening is within an inch or two of meeting the 32" (81 cm) clear opening requirement, it may be possible to replace the standard hinges with off-set hinges to increase the size of the door opening as much as 1 1/2" (3.8 cm). Historic hardware can be retained in place, or adapted with the addition of an automatic opener, of which there are several types. Door hardware can also be retrofitted to reduce door pressures. For example, friction hinges can be retrofitted with ball-bearing inserts, and door closers can be rethreaded to reduce the door pressure.

Altering Door Thresholds. A door threshold that exceeds the allowable height, generally 1/2" (1.3 cm), can be altered or removed with one that meets applicable accessibility



Figure 16. During the rehabilitation of the Rookery in Chicago, the original entrance was modified to create an accessible entrance. Two revolving doors were replaced with a new one flanked by new doors, one of which is operated with a push-plate door opener. Photo: Thomas Jester.

requirements. If the threshold is deemed to be significant, a bevel can be added on each side to reduce its height (See Figure 17). Another solution is to replace the threshold with one that meets applicable accessibility requirements and is visually compatible with the historic entrance.

Moving Through Historic Interiors

Persons with disabilities should have independent access to all public areas and facilities inside historic buildings. The extent to which a historic interior can be modified depends on the significance of its materials, plan, spaces, features, and finishes. Primary spaces are often more difficult to modify without changing their character. Secondary spaces may generally be changed without compromising a building's historic character. Signs should clearly mark the route to accessible restrooms, telephones, and other accessible areas.

Installing Ramps and Wheelchair Lifts. If space permits, ramps and wheelchair lifts can also be used to increase accessibility inside buildings (See Figures 18 & 19). However, some States and localities restrict interior uses of wheelchair lifts for life-safety reasons. Care should be taken to install these new features where they can be readily accessed. Ramps and wheelchair lifts are described in detail on pages 4-6.

Upgrading Elevators. Elevators are an efficient means of providing accessibility between floors. Some buildings have existing historic elevators that are not adequately accessible for persons with disabilities because of their size, location, or detailing, but they may also contribute to the historical significance of a building. Significant historic elevators can usually be upgraded to improve accessibility. Control panels can be modified with a "wand" on a cord to make the control panel accessible, and timing devices can usually be adjusted.

Retrofitting Door Knobs. Historic door knobs and other hardware may be difficult to grip and turn. In recent years, lever-handles have been developed to replace door knobs. Other lever-handle devices can be added to existing hardware. If it is not possible or appropriate to retrofit existing door knobs, doors can be left open during operating hours (unless doing so would violate life safety codes), and power-assisted door openers can be installed. It may only be necessary to retrofit specific doorknobs to create an accessible path of travel and accessible restrooms.

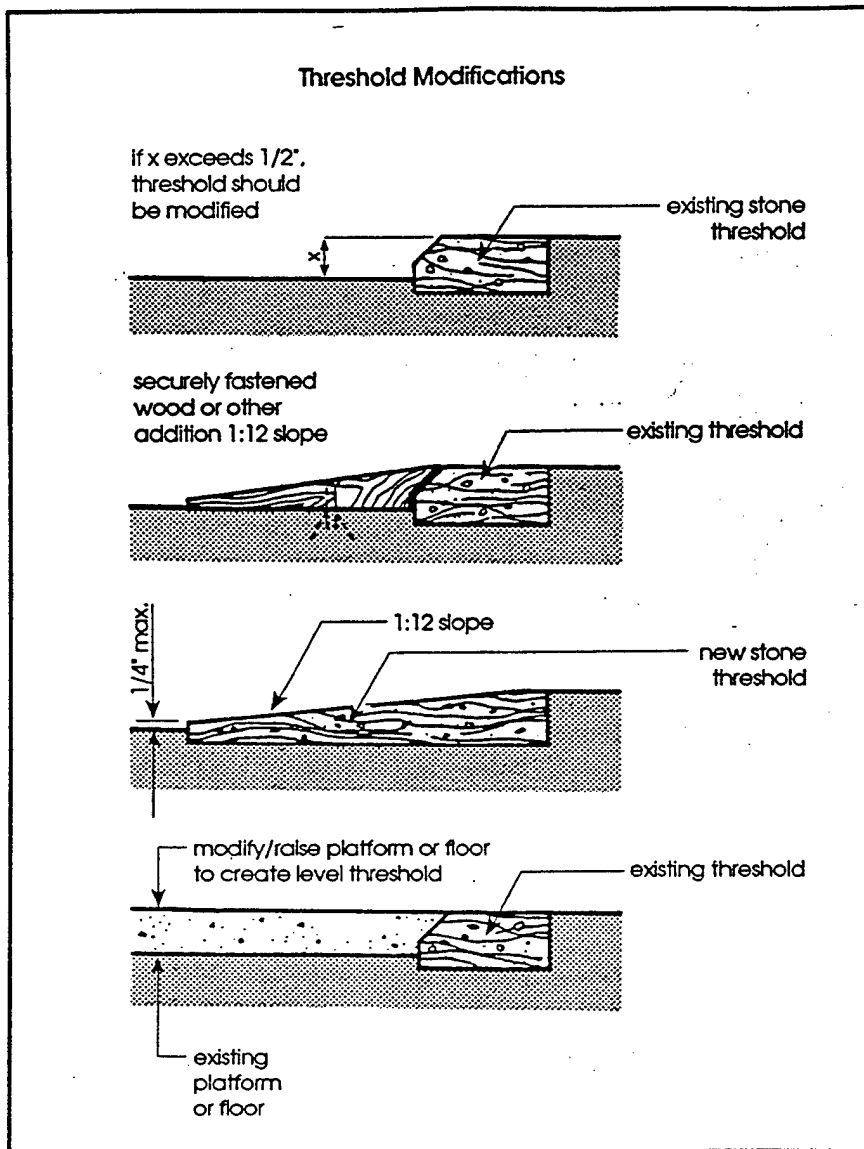

Figure 17. Thresholds that exceed allowable heights can be modified several ways to increase accessibility. Source: Uniform Federal Accessibility Standard (UFAS) Retrofit Manual.

Modifying Interior Stairs. Stairs are the primary barriers for many people with disabilities. However, there are some ways to modify stairs to assist people who are able to navigate them. It may be appropriate to add hand railings if none exist. Railings should be 1 1/4" (3.8 cm) in diameter and return to the wall so straps and bags do not catch. Color-contrasting, slip-resistant strips will help people with visual impairments. Finally, beveled or closed risers are recommended unless the stairs are highly significant, because open risers catch feet (See Figure 20).

Building Amenities

Some amenities in historic buildings, such as restrooms, seating, telephones, drinking fountains, counters, may contribute to a building's historic character. They will often require modification to improve their use by persons with disabilities. In many cases, supplementing existing amenities, rather than changing or removing them, will increase access and minimize changes to historic features and materials.

Upgrading Restrooms. Restrooms may have historic fixtures such as sinks, urinals, or marble partitions that can

be retained in the process of making modifications. For example, larger restroom can sometimes be reconfigured by relocating or combining partitions to create an accessible toilet stall. Other changes to consider are adding grab bars around toilets, covering hot water pipes under sinks with insulation to prevent burns, and providing a sink, mirror, and paper dispenser at a height suitable for wheelchair users. A unisex restroom may be created if it is technically infeasible to create two fully accessible restrooms, or if doing so would threaten or destroy the significance of the building. It is important to remember that restroom fixtures, such as sinks, urinals, and partitions, may be historic, and therefore, should be preserved whenever possible.

Modifying Other Amenities. Other amenities inside historic buildings may require modification. Seating in a theater, for example, can be made accessible by removing some seats in several areas (See Figure 21). New seating that is accessible can also be added at the end of existing rows, either with or without a level floor surface. Readily removable seats may be installed in wheelchair spaces when the spaces are not required to accommodate wheelchair users. Historic water fountains can be retained and new, two-tiered fountains installed if space permits. If public telephones are provided, it may be necessary to install at least a Text Telephone (TT), also known as a Telecommunication Device for the Deaf (TDD) (See Figure 22). Historic service counters commonly found in banks, theaters, and hotels generally should not be altered. It is preferable to add an accessible counter on the end of a historic counter if feasible. Modified or new counters should not exceed 36" (91.5 cm) in height.

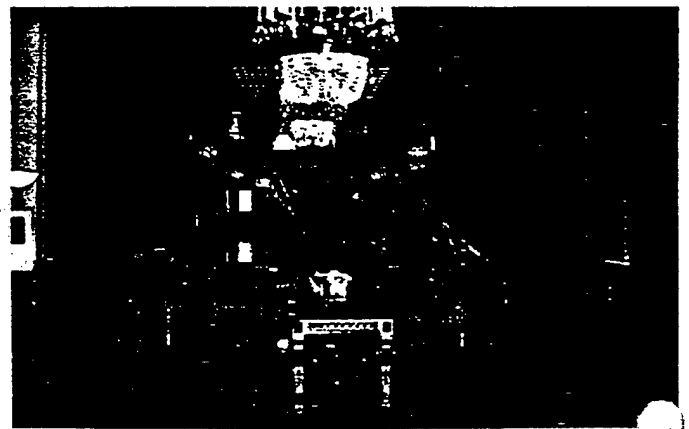
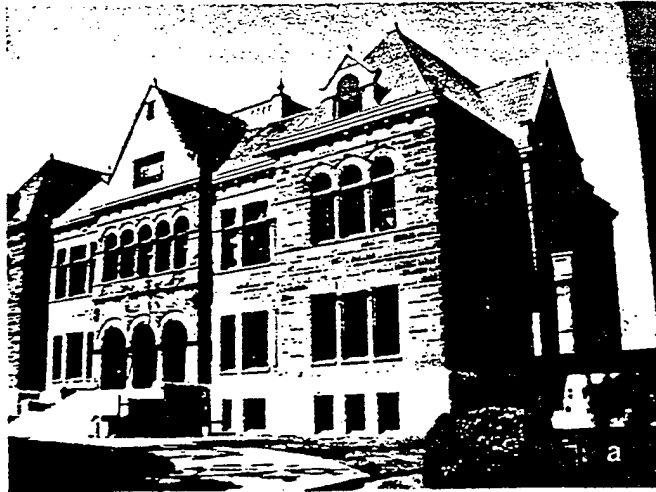
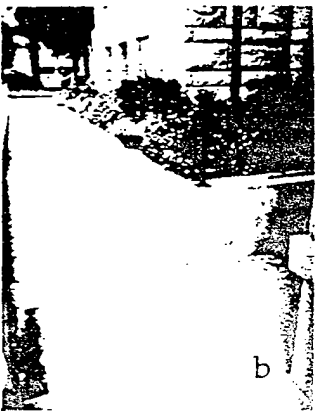

Figure 18. Symmetrical ramps at the Mayflower Hotel in Washington D.C., provide access to the hotel's lower level. The design for the ramps respects the historic character of this landmark building. Photo: Thomas Jester.

MAKING A HISTORIC BUILDING ACCESSIBLE



a



b

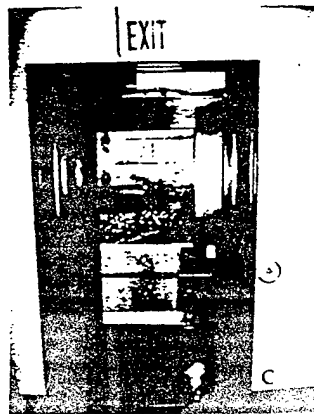

c

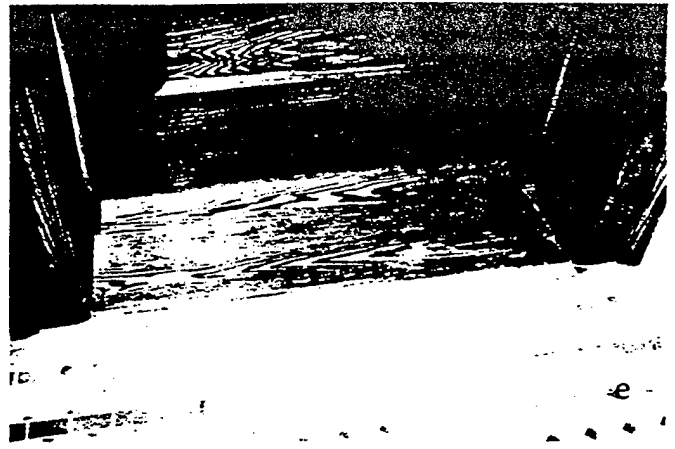

e



f



d

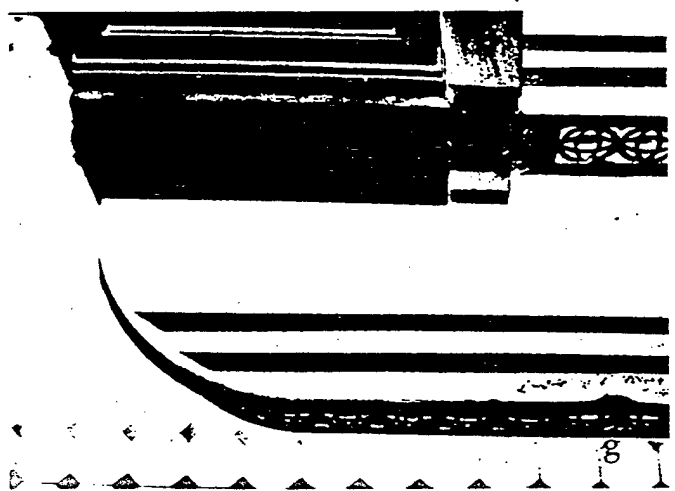

g

The Orange County Courthouse (a), located in Santa Ana, California, was rehabilitated in the late 1980s as a county museum. As part of the rehabilitation, the architect sensitively integrated numerous modifications to increase accessibility. To preserve the building's primary elevation, a new public entrance was created on the rear elevation where parking spaces are located. A ramp (b) leads to the accessible entrance that can be opened with a push-plate automatic door-opener (c). Modifications to interior features also increased accessibility. To create an accessible path of travel, offset hinges (d) were installed on doors that were narrower than 32 inches (81.3 cm). Other doors were rethreaded to reduce the door pressure. Beveling the 1" high thresholds (e) reduced their height to approximately 1/4 inch (6.4 cm). The project architect also converted a storeroom into an accessible restroom (f). The original stairway, which has open grilloork, was made more accessible by applying slip-resistant pressure tape to the marble steps (g). And the original elevator was upgraded with raised markings, alarm lights, and voice floor indicators. Photos: Clifford Wayne Donaldson, FAIA.

MAKING HISTORIC LANDSCAPES ACCESSIBLE

To successfully incorporate access into historic landscapes, the planning process is similar to that of other historic properties. Careful research and inventory should be undertaken to determine which materials and features convey the landscape's historical significance. As part of this evaluation, those features that are character-defining (topographical variation, vegetation, circulation, structures, furnishings, objects) should be identified. Historic finishes, details, and materials that also contribute to a landscape's significance should also be documented and evaluated prior to determining an approach to landscape accessibility. For example, aspects of the pedestrian circulation system that need to be understood include walk width, aggregate size, pavement pattern, texture, relief, and joint details. The context of the walk should be understood including its edges and surrounding area. Modifications to surface textures or widths of pathways can often be made with minimal effect on significant landscape features (a) and (b).

Additionally, areas of secondary importance such as altered paths should be identified – especially those where the accessibility modifications will not destroy a landscape's significance. By identifying those features that are contributing or non-contributing, a sympathetic circulation experience can then be developed.

After assessing a landscape's integrity, accessibility solutions can be considered. Full access throughout a historic landscape may not always be possible. Generally, it is easier to provide accessibility to larger, more open

sites where there is a greater variety of public experiences. However, when a landscape is uniformly steep, it may only be possible to make discrete portions of a historic landscape accessible, and viewers may only be able to experience the landscape from selected vantage points along a prescribed pedestrian or vehicular access route. When defining such a route, the interpretive value of the user experience should be considered; in other words, does the route provide physical or visual access to those areas that are critical to understand the meaning of the landscape?

The following accessibility solutions address three common landscape situations: 1) structures with low integrity landscapes; 2) structures and landscapes of equal significance; and, 3) landscapes of primary significance with inaccessible terrain.

1. The Hunnewell Visitors Center at the Arnold Arboretum in Jamaica Plain, Massachusetts, was constructed in 1892. Its immediate setting has changed considerably over time (c). Since the existing landscape immediately surrounding this structure has little remaining integrity, the new accessibility solution has the latitude to integrate a broad program including site orientation, circulation, interpretation, and maintenance.

The new design, which has few ornamental plants, references the original planting design principles, with a strong emphasis on form, color, and texture. In contrast with the earlier designs, the new plantings were set away from the facade of this historic building



(a.) To improve accessibility in Boston's Emerald Necklace Parks, standard asphalt paving was replaced in selected areas with an imbedded aggregate surface that is more in keeping with the landscape's historic appearance. Photo: Charles Birnbaum.



(b.) The Friendly Garden at Ranchos Los Alamitos, a historic estate with designed gardens in southern California, was made accessible with limited widening of its existing approach path. Photo: Ranchos Los Alamitos Foundation.



(c.) Hunnewell Visitor's Center before rehabilitation, revealing the altered landscapes. Photo: Jennifer Jones, Carol R. Johnson and associates.



(d.) Hunnewell Visitors Center's entrance following rehabilitation, integrating an accessible path (left), platform, and new steps. Photo: Charles Birnbaum.

allowing the visitor to enjoy its architectural detail. A new walk winds up the gentle earthen berm and is vegetated with plantings that enhance the interpretive experience from the point of orientation (d). The new curvilinear walks also provide a connection to the larger arboretum landscape for everyone.

2. The Eugene O'Neill National Historic Site overlooks the San Ramon Valley, twenty-seven miles east of San Francisco, California. The thirteen-acre site includes a walled courtyard garden on the southeast side of the Tao House, which served as the O'Neill residence from 1937-44 (e). Within this courtyard are character-defining walks that are too narrow by today's accessibility standards, yet are a character-defining element of the historic design. To preserve the garden's integrity, the scale and the characteristics of the original circulation were maintained by creating a wheelchair route which, in part, utilizes reinforced turf. This route allows visitors with disabilities to experience the main courtyard as well.
3. Morningside Park in New York City, New York, designed by Frederick Olmstead, Sr., and Calvert Vaux in 1879, is sited on generally steep, rocky terrain (f). Respecting these dramatic grade changes, which are only accessible by extensive flights of stone stairs, physical access cannot be provided without destroying the park's integrity. In order to provide some accessibility, scenic overlooks were created that provide broad visual access to the park.



(e.) This view shows the new reinforced turf path at the Eugene O'Neill National Historic Site that preserved the narrow Historic Path. Photo: Patricia M. O'Donnell.



(f.) Steep terrain at Morningside Park in New York City cannot be made accessible without threatening or destroying this landscape's integrity. Photo: Quennell Rothschild Associates.

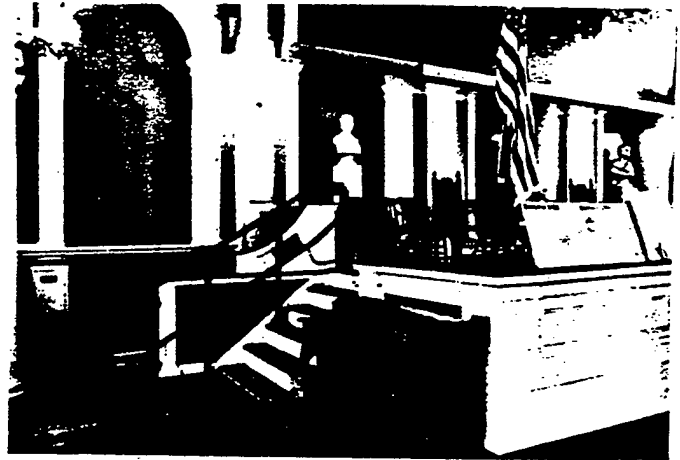

Figure 19. Inclined lifts can sometimes overcome interior changes of elevation where space is limited. This lift in Boston's Faneuil Hall created access to the floor and stage level of the State Room. Photo: Paul Holtz.

Considering a New Addition as an Accessibility Solution

Many new additions are constructed specifically to incorporate modern amenities such as elevators, restrooms, fire stairs, and new mechanical equipment. These new additions often create opportunities to incorporate access for people with disabilities. It may be possible, for example, to create an accessible entrance, path to public levels via a ramp, lift, or elevator (See Figure 23). However, a new addition has the potential to change a historic property's appearance and destroy significant building and landscape features. Thus, all new additions should be compatible with the size, scale, and proportions of historic features and materials that characterize a property (See Figure 24).

New additions should be carefully located to minimize connection points with the historic building, such that if the addition were to be removed in the future, the essential form and integrity of the building would remain intact. On the other hand, new additions should also be conveniently located near parking that is connected to an accessible route for people with disabilities. As new additions are incorporated, care should be taken to protect significant landscape features and archeological resources. Finally, the design for any new addition should be differentiated from the historic design so that the property's evolution over time is clear. New additions frequently make it possible to increase accessibility, while simultaneously reducing the level of change to historic features, materials, and spaces.

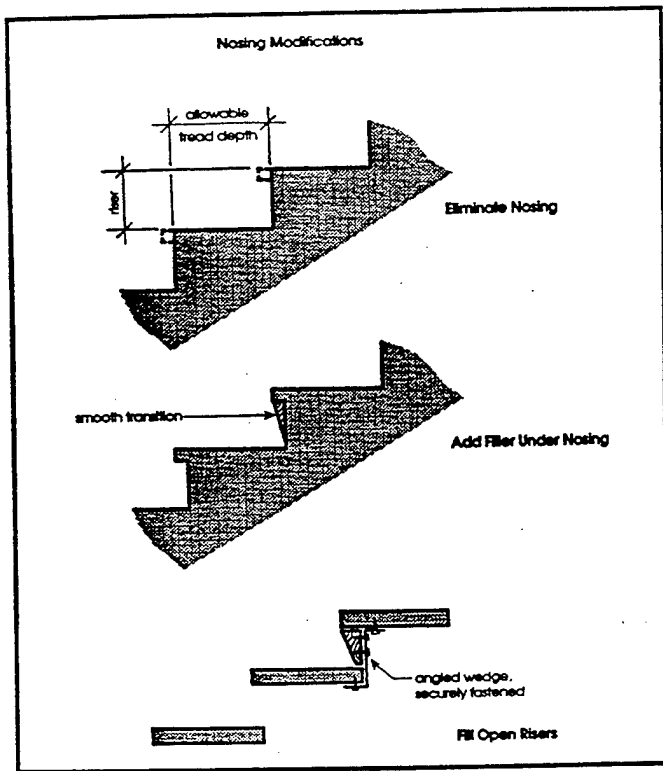

Figure 20. In certain situations it may be appropriate to modify stair nosings for persons with mobility impairments. Whenever possible, stairs should be modified by adding new materials rather than removing historic materials. Source: UFAS Retrofit Manual.

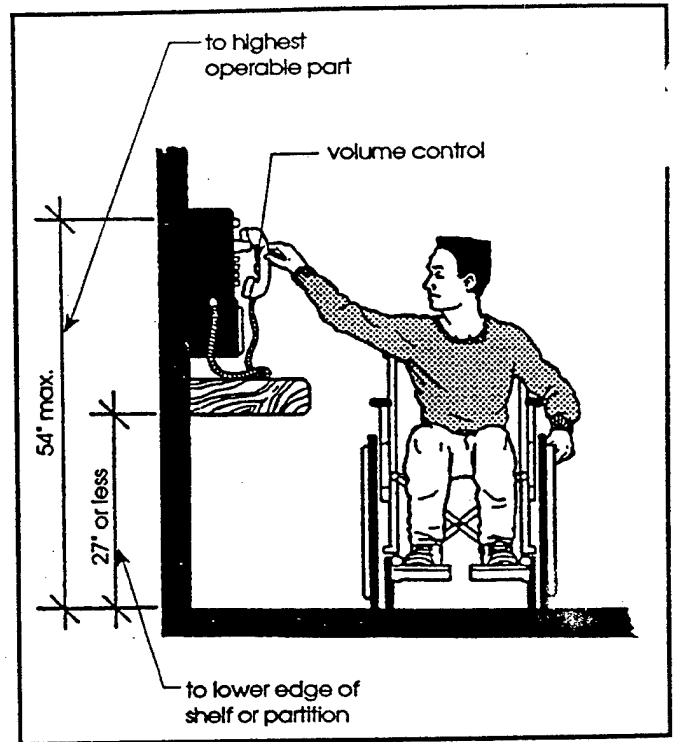

Figure 22. Amenities such as telephones should be at height that wheelchair users can reach. Changes to many amenities can be adapted with minimal effect on historic materials, features, and spaces. Source: UFAS Retrofit Manual.

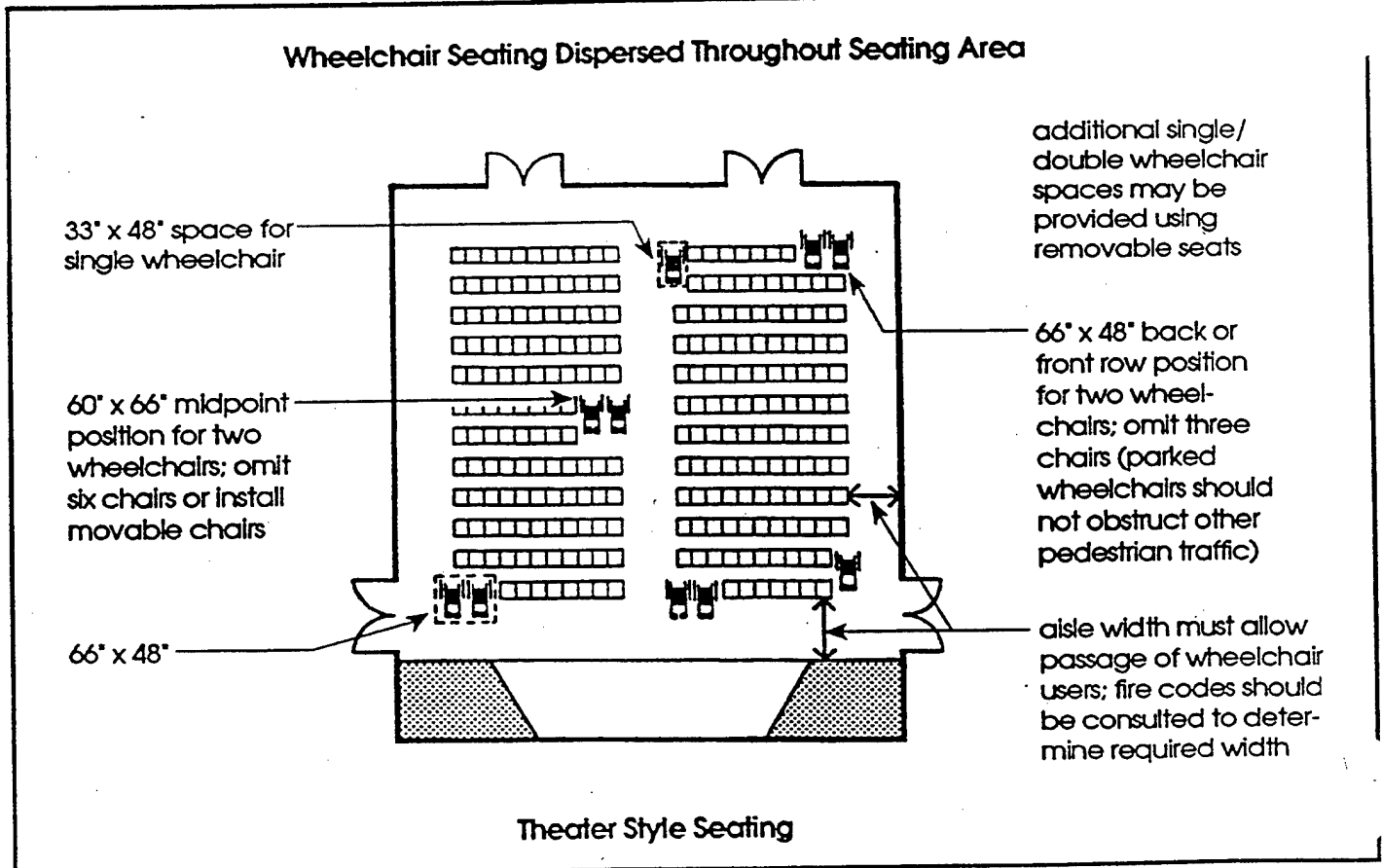

Figure 21. Seating in historic theaters and auditoriums can be changed to accommodate wheelchair users. Accessible seating areas should be connected to an accessible route from the building entrance. Source: UFAS Retrofit Manual.

Federal Accessibility Laws

Today, few building owners are exempt from providing accessibility for people with disabilities. Before making any accessibility modification, it is imperative to determine which laws and codes are applicable. In addition to local and State accessibility codes, the following federal accessibility laws are currently in effect:

Architectural Barriers Act (1968)

The Architectural Barriers Act stipulates that all buildings designed, constructed, and altered by the Federal Government, or with federal assistance, must be accessible. Changes made to federal buildings must meet the Uniform Federal Accessibility Standards (UFAS). Special provisions are included in UFAS for historic buildings that would be threatened or destroyed by meeting full accessibility requirements.

Rehabilitation Act (1973)

The Rehabilitation Act requires recipients of federal financial assistance to make their programs and activities accessible to everyone. Recipients are allowed to make their properties accessible by altering their building, by moving programs and activities to accessible spaces, or by making other accommodations.

Americans with Disabilities Act (1990)

Historic properties are not exempt from the Americans with Disabilities Act (ADA) requirements. To the greatest extent possible, historic buildings must be as accessible as non-historic buildings. However, it may not be possible for some historic properties to meet the general accessibility requirements.

Under Title II of the ADA, State and local governments must remove accessibility barriers either by shifting services and programs to accessible buildings, or by making alterations to existing buildings. For instance, a licensing office may be moved from a second floor to an accessible first floor space, or if this is not feasible, a mail service might be provided. However, State and local government facilities that have historic preservation as their main purpose—State-owned historic museums, historic State capitols that offer tours—must give priority to physical accessibility.

Under Title III of the ADA, owners of "public accommodations" (theaters, restaurants, retail shops, private museums) must make "readily achievable" changes; that is, changes that can be easily accomplished without much expense. This might mean installing a ramp, creating accessible parking, adding grab bars in bathrooms, or modifying door hardware. The requirement to remove barriers when it is "readily achievable" is an ongoing responsibility. When alterations, including restoration and rehabilitation work, are made, specific accessibility requirements are triggered.

Recognizing the national interest in preserving historic properties, Congress established alternative requirements for properties that cannot be made accessible without "threatening or destroying" their significance. A consultation process is outlined in the ADA's Accessibility Guidelines for owners of historic properties who believe that making specific accessibility modifications would "threaten or destroy" the significance of their property. In these situations, after consulting with persons with disabilities and disability organizations, building owners should contact the State Historic Preservation Officer (SHPO) to determine if the special accessibility provisions for historic properties apply. If it is determined by consultation with the SHPO that compliance with the accessibility requirements would threaten or destroy the significance of the property, alternative methods of access, such as home delivery and curbside pick-ups, may be used.



Figure 23. New additions to historic buildings can be designed to increase accessibility. A new addition links two adjacent buildings used for the Albany, New York, Visitor's Center, and incorporates an accessible entrance, restrooms, and signage. Photo: Clare Adams.

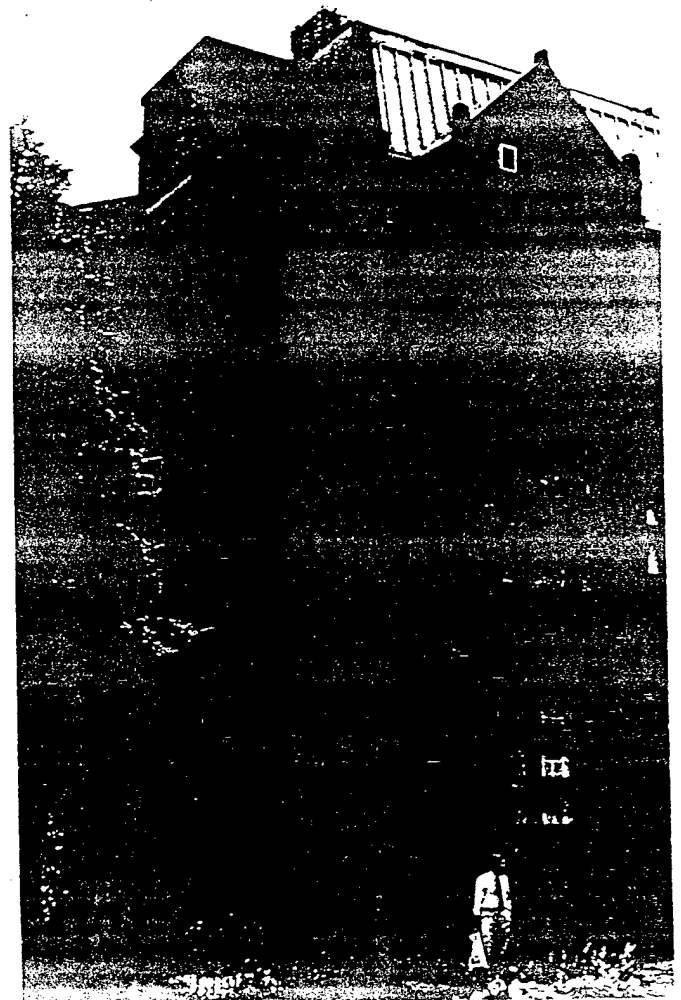

Figure 24. Creating an accessible entrance with a new elevator tower provides a compatible design. This elevator addition blends in with the historic building and provides access to all building levels.

Conclusion

Historic properties are irreplaceable and require special care to ensure their preservation for future generations. With the passage of the Americans with Disabilities Act, access to historic properties open to the public is a now civil right, and owners of historic properties must evaluate existing buildings and determine how they can be made more accessible. It is a challenge to evaluate properties thoroughly, to identify the applicable accessibility requirements, to explore alternatives and to implement solutions that provide independent access and are consistent with accepted historic preservation standards. Solutions for accessibility should not destroy a property's significant materials, features and spaces, but should increase accessibility as much as possible. Most historic buildings are not exempt from providing accessibility, and with careful planning, historic properties can be made more accessible, so that all citizens can enjoy our Nation's diverse heritage.



Photo: Massachusetts Historical Commission.

Acknowledgements

Thomas C. Jester is an Architectural Historian with the Preservation Assistance Division of the National Park Service. Sharon C. Park, AIA, is the Senior Historical Architect with the Preservation Assistance Division, National Park Service.

The authors wish to thank Charles A. Birnbaum, ASLA, Historical Landscape Architect with the Preservation Assistance Division, National Park Service, for contributing the section on historic landscapes. The authors gratefully acknowledge the invaluable comments made by the following individuals who reviewed the draft manuscript: William Smith, Massachusetts Historical Commission; Kay Weeks, H. Ward Jandl, Michael Auer, and Charles A. Birnbaum, Preservation Assistance Division, National Park Service; Clare Adams, New York Department of Parks, Recreation and Historic Preservation; Lauren Bowlin, Maryland Historical Trust; Tom Mayes, National Trust for Historic Preservation; Elizabeth Igleheart, Maine Historic Preservation

Additional Reading

- Ballantyne, Duncan S. and Harold Russell Associates, Inc. *Accommodation of Disabled Visitors at Historic Sites in the National Park System*. Washington, D.C.: Park Historic Architecture Division, National Park Service, U.S. Department of the Interior, 1983.
- Goldman, Nancy. Ed. *Readily Achievable Checklist: A Survey for Accessibility*. Boston: Adaptive Environments Center, 1993.
- Hayward, Judith L. and Thomas C. Jester, compilers. *Accessibility and Historic Preservation Resource Guide*. Windsor, Vermont: Historic Windsor, Inc., 1992, revised 1993.
- Jester, Thomas C. *Preserving the Past and Making it Accessible for People with Disabilities*. Washington, D.C.: Preservation Assistance Division, National Park Service, U.S. Department of the Interior, 1992.
- Parrott, Charles. *Access to Historic Buildings for the Disabled*. Washington, D.C.: U.S. Department of the Interior, 1980.
- Secretary of the Interior's Standards for the Treatment of Historic Properties*. Washington, D.C.: Preservation Assistance Division, National Park Service, U.S. Department of the Interior, 1993.
- Smith, William D. and Tara Goodwin Frier. *Access to History: A Guide to Providing Access to Historic Buildings for People with Disabilities*. Boston: Massachusetts Historical Commission, 1989.
- Standards for Accessible Design: ADA Accessibility Guidelines (ADAAG)*. Washington, D.C.: U.S. Department of Justice, 1991.

Commission; Milford Wayne Donaldson, FAIA; Paul Beatty, U.S. Architectural and Transportation Barriers Compliance Board; Mid-Atlantic Regional Office, National Park Service; Western Regional Office, National Park Service.

This publication has been prepared pursuant to the National Historic Preservation Act of 1966, as amended, which directs the Secretary of the Interior to develop and make available information concerning historic properties. Comments about this publication should be directed to H. Ward Jandl, Deputy Chief, Preservation Assistance Division, National Park Service, P.O. Box 37127, Washington, D.C. 20013-7127. This publication is not copyrighted and can be reproduced without penalty. Normal procedures for credit to the authors at the National Park Service are appreciated.

37 PRESERVATION BRIEFS

Appropriate Methods for Reducing Lead-Paint Hazards in Historic Housing

Sharon C. Park, AIA, and Douglas C. Hicks



U.S. Department of the Interior
National Park Service
Cultural Resources
Preservation Assistance

Lead-based paint, a toxic material, was widely used in North America on both the exteriors and interiors of buildings until well into the second half of the twentieth century. If a "historic" place is broadly defined in terms of time as having attained an age of fifty years, this means that almost every historic house contains some lead-based paint. In its deteriorated form, it produces paint chips and lead-laden dust particles that are a known health hazard to both children and adults. Children are particularly at risk when they ingest lead paint dust through direct hand-to-mouth contact and from toys or pacifiers. They are also at risk when they chew lead-painted surfaces in accessible locations. In addition to its presence in houses, leaded paint

chips, lead dust, or lead-contaminated soil in play areas can elevate a child's blood lead level to a degree that measures to reduce and control the hazard should be undertaken (see Action Level Chart, page 6)

The premise of this Preservation Brief is that historic housing can be made lead-safe for children without removing significant decorative features and finishes, or architectural trimwork that may contribute to the building's historic character (see fig. 1). *Historic housing* — encompassing private dwellings and all types of rental units—is necessarily the focus of this Brief because federal and state laws primarily address the hazards of lead and

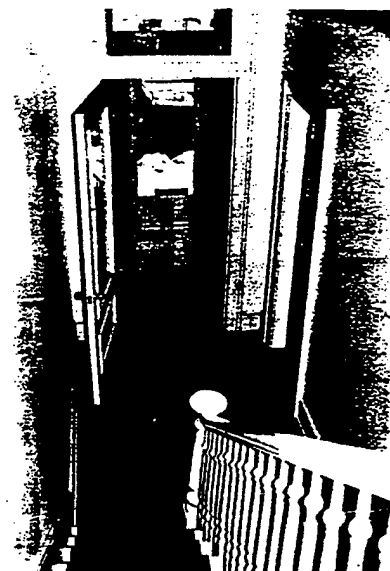

Before



After

Figure 1. A large-scale historic rehabilitation project incorporated sensitive lead-hazard reduction measures. Interior walls and woodwork were cleaned, repaired, and repainted and compatible new floor coverings added. The total project was economically sound and undertaken in a careful manner that preserved the building's historic character. Photos: Landmarks Design Associates.

lead-based paint in housing and day-care centers to protect the health of children under six years of age. Rarely are there mandated requirements for the removal of lead-based paint from non-residential buildings.

Ideally, most owners and managers should understand the health hazards created by lead-based paint and voluntarily control these hazards to protect young children. A stricter approach has been taken by some state and federal funding programs which have compliance requirements for identifying the problem, notifying tenants, and, in some cases, remedying lead hazards in housing (see Legislation Sidebar, pg.15). With new rules being written, and new products and approaches being developed, it is often difficult to find systematic and balanced methodologies for dealing with lead-based paint in historic properties.

This Preservation Brief is intended to serve as an introduction to the complex issue of historic lead-based paint and its management. It explains how to plan and implement lead-hazard control measures to strike a balance between preserving a historic building's significant materials and features and protecting human health and safety, as well as the environment. It is not meant to be a "how-to guide" for undertaking the work. Such a short-cut approach could easily result in creating a greater health risk, if proper precautions were not taken. Home renovators and construction workers should be aware that serious health problems can be caused by coming into contact with lead. For this reason, there are also laws to protect workers on the job site (see Worker Safety Sidebar, pg. 4). Controlling the amount of waste containing lead-based paint residue will also reduce the impact on the environment. All of these considerations must be weighed against the goal of providing housing that is safe for children.

Lead in Historic Paints

Lead compounds were an important component of many historic paints. Lead, in the forms of lead carbonate and lead oxides, had excellent adhesion, drying, and covering abilities. White lead, linseed oil, and inorganic pigments were the basic components for paint in the 18th, 19th, and early 20th centuries. Lead-based paint was used extensively on wooden exteriors and interior trimwork, window sash, window frames, baseboards, wainscoting, doors, frames, and high gloss wall surfaces such as those found in kitchens and bathrooms. Almost all painted metals were primed with red lead or painted with lead-based paints. Even milk (casein) and water-based paints (distemper and calcimines) could contain some lead, usually in the form of hiding agents or pigments. Varnishes sometimes contained lead. Lead compounds were also used as driers in paint and window glazing putty.

In 1978, the use of lead-based paint in residential housing was banned by the federal government. Because the hazards have been known for some time, many lead components of paint were replaced by titanium and other less toxic elements earlier in the 20th century. Since houses are periodically repainted, the most recent layer of paint will most likely *not* contain lead, but the older layers underneath probably will. Therefore, the only way to accurately determine the amount of lead present in older paint is to have it analyzed.

It is important that owners of historic properties be aware that layers of older paint can reveal a great deal about the history of a building and that paint chronology is often used to date alterations or to document decorative period colors (see figs. 2, 3). Highly significant decorative finishes, such as graining, marbleizing, stenciling, polychrome decoration, and murals should be evaluated by a painting conservator to develop the appropriate preservation treatment that will stabilize the paint and eliminate the need to remove it. If such finishes must be removed in the process of controlling lead hazards, then research, paint analysis, and documentation are advisable as a record for future research and treatment.

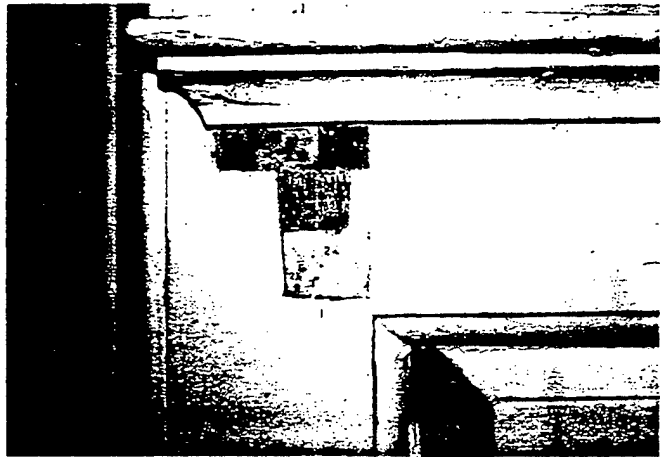

Figure 2. The paint chronology of this mantel, seen in the exposed paint layers in the left corner, proved it had been relocated from another room in the house. To remove a significant feature's paint history and the evidence of its original sequence of color by stripping off all the paint is inappropriate — and unnecessary — as part of a lead hazard reduction project. Careful surface preparation and repainting with lead-free top coats is recommended. Photo: NPS Files.

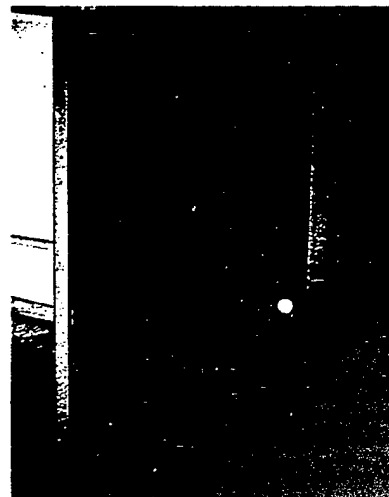
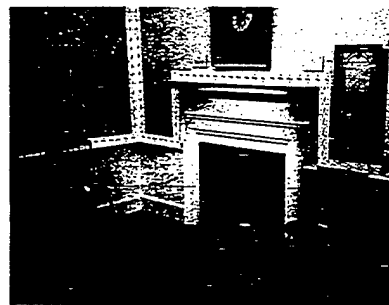

Figure 3. Significant architectural features and their finishes should not be removed during a project incorporating lead hazard controls. If the decorative stencilling above, or hand grained doors below, or painted murals need repair, then a paint conservator should be consulted. Once loose paint is consolidated or otherwise stabilized, a clear finish or other reversible clear protective surface or coating can be added to areas subject to impact or abrasion. Photos: NPS Files.

Planning for Lead Hazard Reduction in Historic Housing

Typical health department guidelines call for removing as much of the surfaces that contain lead-based paint as possible. *This results in extensive loss or modification of architectural features and finishes and is not appropriate for most historic properties* (see fig. 4). A great number of federally-assisted housing programs are moving away from this approach as too expensive and too dangerous to the immediate work environment. A preferred approach, consistent with *The Secretary of the Interior's Standards for the Treatment of Historic Properties*, calls for removing, controlling, or managing the hazards rather than wholesale—or even partial—removal of the historic features and finishes (fig. 5). This is generally achieved through careful cleaning and treatment of deteriorating paint, friction surfaces, surfaces accessible to young children, and lead in soil (see figs. 6, 7). Lead-based paint that it not causing a hazard is thus permitted to remain, and, in consequence, the amount of historic finishes, features and trimwork removed from a property is minimized.

Because the hazard of lead poisoning is tied to the risk of ingesting lead, careful planning can help to determine how

much risk is present and how best to allocate available financial resources. An owner, with professional assistance, can protect a historic resource and make it lead-safe using this three-step planning process:

- I. Identify the historical significance of the building and architectural character of its features and finishes;
 - II. Undertake a risk assessment of interior and exterior surfaces to determine the hazards from lead and lead-based paint; and,
 - III. Evaluate the options for lead hazard control in the context of historic preservation standards.
- I. **Identify the historical significance of the building and architectural character of its features and finishes**

The historical significance, integrity, and architectural character of the building always need to be assessed before work is undertaken that might adversely affect them. An owner may need to enlist the help of a preservation architect, building conservator or historian. The State Historic Preservation Office (SHPO) may be able to provide a list of knowledgeable preservation professionals who could assist with this evaluation.



Before



After

Figure 4. The typical method for abating lead-based paint through substrate removal is not consistent with the Standards for Rehabilitation. In this project, all the historic trim, base panels, and the transom were removed. While the unit is lead-safe, its character has been severely altered. Figure 5 shows a similar, but successful, balance of historic preservation and lead hazard control work. Photo: NPS Files.



Before

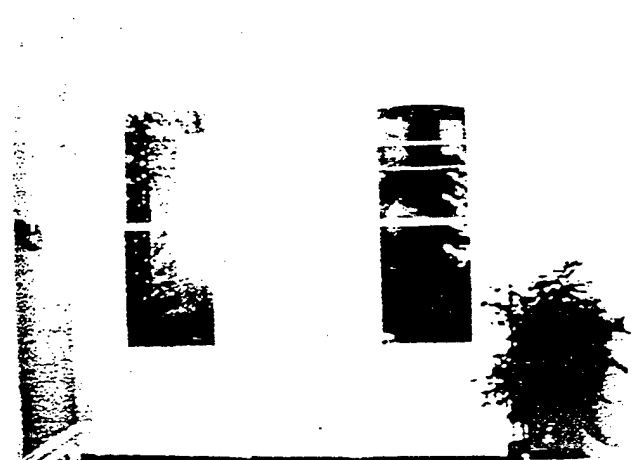

After

Figure 5. When historic interiors are rehabilitated, it is possible to remove the offending substance, such as deteriorated paint, without removing the features. In this case, the walls were repaired, and the trim and base panels were stripped of paint to a sound substrate, then repainted. Photos: Landmarks Design Associates.

Worker Safety

Current worker safety standards were established by OSHA's 29 CFR Part 1926, Lead Exposure in Construction; Interim Final Rule, which became effective June 3, 1993. These standards base levels of worker protection on exposure to airborne lead dust.

They are primarily targeted to persons working within the construction industry, but apply to any workers who are exposed to lead dust for

longer than a specific amount of time and duration. The Interim Final Rule establishes an action level of 30 micrograms of lead dust per cubic meter of air ($30 \mu\text{g}/\text{m}^3$) based on an eight hour, time-weighted average, as the level at which employers must initiate compliance activities; and it also establishes $50 \mu\text{g}/\text{m}^3$ of lead dust as the permitted exposure level (PEL) for workers.

The standard identifies responsibilities before, during, and after the actual abatement activity necessary to protect the worker. Before the project begins, it requires an exposure assessment, a written compliance plan, initial medical surveillance, and training. The exposure assessment determines whether a worker may be exposed to lead. OSHA has identified a number of work tasks expected to produce dust levels between 50 and $500 \mu\text{g}/\text{m}^3$ of air, including manual demolition, manual scraping, manual sanding, heat gun applications, general cleanup, and power tool use when the power tool is equipped with a dust collection system. It is an OSHA requirement that, at a minimum, a HEPA filtered half-face respirator with a protection factor of 10 be used for these operations. Initial blood lead level (BLL) base lines are established for each worker. Actual dust levels are monitored by air sampling of representative work activities, generally by an industrial hygienist or an environmental monitoring firm. Protective equipment is determined by the dust level. For all workers exposed at, or above, the action level for over 30 days in a 12-month period, BLLs are tested on a regular basis of every 2 months for the first 6 months and every 6 months thereafter. After completing a project, maintenance, medical surveillance, and recordkeeping responsibilities continue.

HEPA vacuums, HEPA respirators, and HEPA filters, which substantially reduce exposure to lead dust, are available through laboratory safety and supply catalogs and vendors.

Copies of 29 CFR Part 1926, Lead Exposure in Construction: Interim Final Rule are available from the Department of Labor, Occupational Safety and Health Administration, or may be found in any library with a current edition of the Code of Federal Regulation (CFR).



Low-level heat guns can be used to remove lead-based paint from significant historic windows and trimwork, but a worker exposed to lead dust over an extended period of time must be protected from the hazards created during the process of paint removal. Photo: Williamsport Preservation Training Center.

Features and finishes of a historic building that exhibit distinctive characteristics of an architectural style; represent work by specialized craftsmen; or possess high artistic value should be identified so they can be protected and preserved during treatment. When it is absolutely necessary to remove a significant architectural feature or finish—as noted in the first two priorities listed below—it should be replaced with a new feature and finish that matches in design, detail, color, texture, and, in most cases, material.

Figure 6. Deteriorating operable windows often contribute to lead dust in a house. Peeling paint and small particles from abraded surfaces collect in window troughs or sills and are then carried inside by air currents, settling on floors. When the lead dust mixes with regular house dust, it can easily be ingested by a child through hand to mouth contact. In homes with small children, floors and other surfaces should be kept as clean as possible to avoid lead contamination.

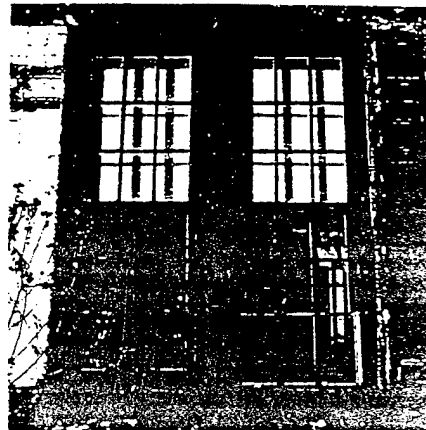
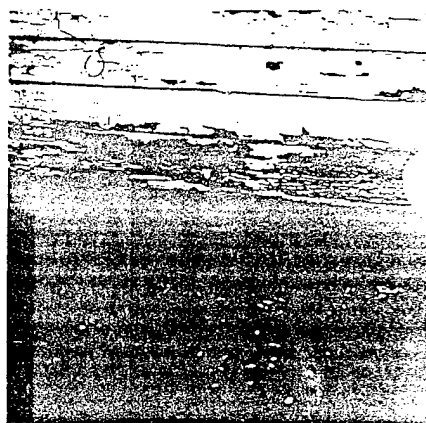

Figure 7. Chalking exterior paint can cause dangerous lead levels in soil around a house. Lead levels are usually highest in the one foot wide area adjacent to the building foundation. In these cases, the existing soil should be replaced with new soil or sod. This is particularly important if children and small pets play in contaminated areas, then inadvertently track the dirt inside.



Finally, features and finishes that characterize simple, vernacular buildings should be retained and preserved; in the process of removing hazards, there are usually reasonable options for their protection. Wholesale removal of historic trim, and other seemingly less important historic material, undermines a building's overall character and integrity and, thus, is never recommended.

For each historic property, features will vary in significance. As part of a survey of each historic property (see figure 8), a list of priorities should be made, in this order:

- *Highly significant features and finishes that should always be protected and preserved;*
- *Significant features and finishes that should be carefully repaired or, if necessary, replaced in-kind or to match all visual qualities; and*
- *Non-significant features and finishes where removal, significant enclosure, or replacement could occur.*

This hierarchy gives an owner a working guide for making decisions about appropriate methods of removing lead-based paint.



Before

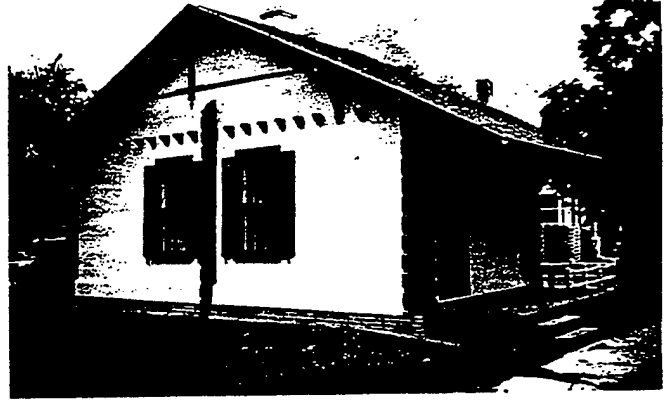

After

Figure 8. A survey of the property will help establish priorities for treatment based on its historical significance and physical condition. In this 1878 plank house, the original interlocking planks, corner details, projecting rafter tails, and original windows were considered highly significant features and were carefully stripped of failing paint using chemical poultices and HEPA sanding, then repainted. The less significant, but character-defining, painted porch flooring was replaced in new, but matching material. The non-historic porch screening was removed entirely. Photo before: Bryan Blundell; Photo after: Deborah Birch.

II. Undertake a risk assessment of interior and exterior surfaces to determine hazards from lead and lead-based paint.

While it can be assumed that most historic housing contains lead-based paint, it cannot be assumed that it is causing a health risk and should be removed. The purpose of a risk assessment is to determine, through testing and evaluation, where hazards from lead warrant remedial action (see fig. 9). Testing by a specialist can be done on paint, soil, or lead dust either on-site or in a laboratory using methods such as x-ray fluorescence (XRF) analyzers, chemicals, dust wipe tests, and atomic absorption spectroscopy. Risk assessments can be fairly low cost investigations of the location, condition, and severity of lead hazards found in house dust, soil, water, and deteriorating paint. Risk assessments will also address other sources of lead from hobbies, crockery, water, and the parents' work environment. A public health office should be able to provide names of certified risk assessors, paint

inspectors, and testing laboratories. These services are critical when owners are seeking to implement measures to reduce suspected lead hazards in housing, day-care centers, or when extensive rehabilitations are planned.

The risk assessment should record:

- the paint's location
- the paint's condition
- lead content of paint and soil
- the type of surface (friction; accessible to children for chewing; impact)
- how much lead dust is actively present
- how the family uses and cares for the house
- the age of the occupants who might come into contact with lead paint.



a



b



c

Figure 9. A variety of testing methods are used to establish how much lead is in paint and where this paint is located: a home test kit (a) is a good screening device to determine if lead is present, but it should not be relied upon exclusively; an X-ray Fluorescence machine or scanner (b), used by a licensed professional, determines, without disturbing the surface, if lead is present in underlying layers of paint; and a dust wipe test (c), sent to a laboratory for processing, can be used as either a clearance test, once work is completed, or as a monitoring device to determine if lead dust is present on surfaces. Paint chips can also be sent to a laboratory for analysis to determine the exact amount of lead by weight in a sample.

ACTION LEVELS

Readers should become familiar with terminology and basic levels that trigger concern and/or action. Check with the appropriate authorities if you have questions and to verify applicable action levels which may change over time.

Blood lead levels: Generally from drawn blood and not a finger stick test which can be unreliable. Units are measured in micrograms per deciliter ($\mu\text{g}/\text{dl}$) and reflect the 1995 standards from the Centers for Disease Control:

Children: 10 $\mu\text{g}/\text{dl}$; level of concern; find source of lead
15 $\mu\text{g}/\text{dl}$ and above; intervention, counseling, medical monitoring.
20 $\mu\text{g}/\text{dl}$ and above; medical treatment

Adults: 25 $\mu\text{g}/\text{dl}$; level of concern; find source of lead
50 $\mu\text{g}/\text{dl}$; OSHA standard for medical removal from the worksite

Lead in paint: Differing methods report results in differing units. Lead is considered a potential hazard if above the following levels, but can be a hazard at lower levels, if improperly handled. These are the current numbers as identified by the Department of Housing and Urban Development (1995).

Lab analysis of samples:

5,000 milligram per kilogram (mg/kg) or 5,000 parts per million (ppm), or
0.5% lead by weight.

XRF reading: in milligram per centimeter squared
1 mg/cm^2

lead dust wipe test: in micrograms per square foot

Floors	100 $\mu\text{g}/\text{ft}^2$;
Window sills	500 $\mu\text{g}/\text{ft}^2$;
Window troughs	800 $\mu\text{g}/\text{ft}^2$

Lead in soil: high contact bare play areas, listed as parts per million (ppm):

concern:	400 ppm
interim control	2,000 ppm
hazard abatement	5,000 ppm

It is important from a health standpoint that future tenants, painters, and construction workers know that lead-based paint is present, even under treated surfaces, in order to take precautions when work is undertaken in areas that will generate lead dust. Whenever mitigation work is completed, it is important to have a clearance test using the *dust wipe method* to ensure that lead-laden dust generated during the work does not remain at levels above those established by the Environmental Protection Agency (EPA) and the Department of Housing and Urban Development (HUD) (see Action Levels Chart, above). A building file should be maintained and updated whenever any additional lead hazard control work is completed.

Hazards should be removed, mitigated, or managed in the order of their health threat, as identified in a risk assessment (with 1. the greatest risk and 8. the least dangerous):

1. Peeling, chipping, flaking, and chewed interior lead-based paint and surfaces
2. Lead dust on interior surfaces
3. High lead in soil levels around the house and in play areas (check state requirements)

4. Deteriorated exterior painted surfaces and features
5. Friction surfaces subject to abrasion (windows, doors, painted floors)
6. Accessible, chewable surfaces (sills, rails) if small children are present
7. Impact surfaces (baseboards and door jambs)
8. Other interior surfaces showing age or deterioration (walls and ceilings)

III. Evaluate options for hazard control in the context of historic preservation standards.

The Secretary of the Interior's Standards for the Treatment of Historic Properties—established principles used to evaluate work that may impact the integrity and significance of National Register properties—can help guide suitable health control methods. The *preservation standards* call for the protection of historic materials and historic character of buildings through stabilization, conservation, maintenance, and repair. The *rehabilitation standards* call for the repair of historic materials with replacement of a character-defining feature appropriate only when its deterioration or damage is so extensive that repair is infeasible. From a preservation standpoint, selecting a hazard control method that removes *only* the deteriorating paint, or that involves some degree of repair, is always preferable to the total replacement of a historic feature.

By tying the remedial work to the areas of risk, it is possible to limit the amount of intrusive work on delicate or aging features of a building without jeopardizing the health and safety of the occupants. To make historic housing lead-safe, the gentlest method possible should be used to remove the offending substance—lead-laden dust, visible paint chips, lead in soil, or extensively deteriorated paint. Overly aggressive abatement may damage or destroy much more historic material than is necessary to remove lead paint, such as abrading historic surfaces. Another reason for targeting paint removal is to limit the amount of lead dust on the work site. This, in turn, helps avoid expensive worker protection, cleanup, and disposal of larger amounts of hazardous waste.

Whenever extensive amounts of lead must be removed from a property, or when methods of removing toxic substances will impact the environment, it is extremely important that the owner be aware of the issues surrounding worker safety, environmental controls, and proper disposal (see fig. 10, 11). Appropriate architectural, engineering and environmental professionals should be consulted when lead hazard projects are complex.

Following are brief explanations of the two approaches for controlling lead hazards, once they have been identified as a risk. These controls are recommended by the Department of Housing and Urban Development in *Guidelines for the Evaluation and Control of Lead-Paint Hazards in Housing*, and are summarized here to focus on the special considerations for historic housing:

Interim Controls: Short-term solutions include thorough dust removal; thorough washdown and clean-up of exposed surfaces; paint film stabilization and repainting covering of lead-contaminated soil; and making tenants aware of lead hazards. Interim controls require ongoing maintenance and evaluation.



Figure 10. The choice of paint removal method will trigger various environmental controls and worker protection. The chemical poultice-type paint remover uses a paper backing that keeps the lead waste contained for proper disposal. The worker is adequately protected by a suit and gloves; for this work a respirator was not required. Local laws required containment and neutralization of any after-wash water run off. Photo: NPS Files.



Figure 11. New methods are being developed or adapted to safely remove lead-based paint from various substrates. On this cast iron building undergoing rehabilitation for apartment units, multiple layers of lead-based paint were removed with pneumatic needle guns with vacuum attachments. Paint chips and waste containing lead-based paint were placed in 55 gallon drums for transport to a special waste site, and the workers were fully protected. The cleaned metal was primed and repainted. Photo: Building Conservation Associates, Inc.

Hazard Abatement: Long-term solutions are defined as having an expected life of 20 years or more, and involve permanent removal of hazardous paint through chemicals, heat guns or controlled sanding/abrasive methods; permanent removal of deteriorated painted features through replacement; the removal or permanent covering of contaminated soil; and the use of enclosures (such as drywall) to isolate painted surfaces. The use of specialized elastomeric encapsulant paints and coatings can be considered as permanent containment of lead-based paint if they receive a 20-year manufacturer's warranty or are approved by a certified risk assessor. One should be aware of their advantages and drawbacks for use in historic housing.

Within the context of the historic preservation standards, the most appropriate method will always be the least invasive. More invasive approaches are considered only under the special circumstances outlined in the three-step

process. An inverted triangle (see fig. 12) shows the greatest number of residential projects fall well within the "interim controls" section. Most housing can be made safe for children using these sensitive treatments, particularly if no renovation work is anticipated. Next, where owners may have less control over the care and upkeep of housing and rental units, more aggressive means of removing hazards may be needed. Finally, large-scale projects to rehabilitate housing or convert non-residential buildings to housing may successfully incorporate "hazard abatement" as a part of the overall work.

Appropriate Methods for Controlling Lead Hazards

In selecting appropriate methods for controlling lead hazards, it is important to refer to Step I. of the survey where architecturally significant features and finishes are identified and need to be preserved. Work activities will vary according to hazard abatement needs; for example, while an interim control would be used to stabilize paint on most trimwork, an accessible window sill might need to be stripped prior to repainting. Since paint on a window sill is usually not a significant finish, such work would be appropriate. Other appropriate methods for controlling lead hazards are summarized in the accompanying chart (see fig. 13).

The method selected for removing or controlling the hazards has a direct bearing on the type of worker protection as well as the type of disposal needed, if waste is determined to be hazardous (see fig. 14). Following are

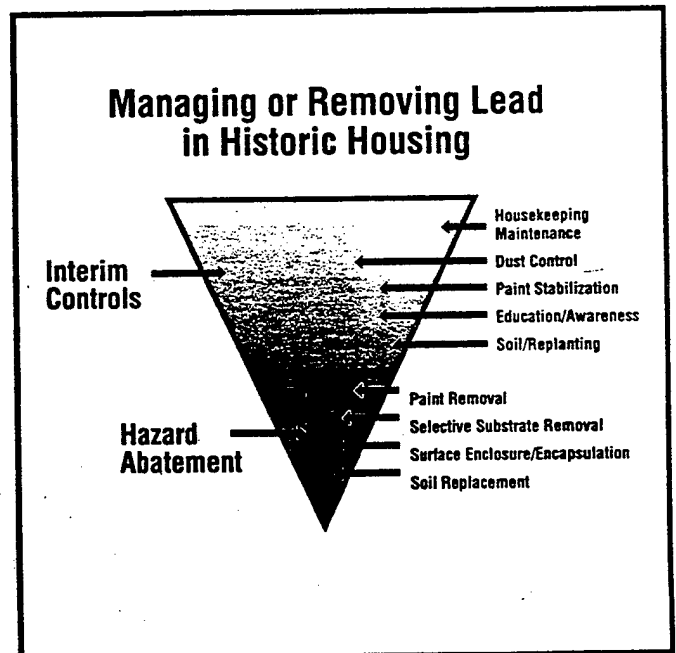

Figure 12. An inverted triangle makes the point that most of the nation's housing can be made lead-safe using interim control methods, such as dust control, paint stabilization, and good housekeeping. Shaded from light to dark, the lighter interim controls will generally not harm the historic materials. The darker, more aggressive controls, can be implemented with rehabilitation projects where paint removal, selective replacement of deteriorated elements, and encapsulation or enclosure are incorporated into other work.

MANAGING OR REMOVING LEAD-BASED PAINT IN HISTORIC BUILDINGS

Interim solutions, the preferred approach, include a combination of the following:

General maintenance	Dust control	Paint stabilization	Soil treatment	Tenant education
<p>Repair deteriorated materials;</p> <p>Control leaks;</p> <p>Maintain exterior roofs, siding, etc. to keep moisture out of building;</p> <p>Perform emergency repairs quickly if lead-based paint is exposed;</p> <p>Maintain building file with lead test data and reports, receipts or invoices on completed lead mitigation work.</p>	<p>Damp mop floor; wet broom sweep porches and steps;</p> <p>Damp dust window sills and window troughs;</p> <p>Washdown painted surfaces periodically (use tri-sodium phosphate or equivalent, if necessary);</p> <p>Clean or vacuum carpets regularly (use HEPA vacuum if lead dust returns);</p> <p>Undertake periodic inspection with annual dust wipe tests.</p>	<p>Wet-sand loose paint and repaint;</p> <p>Keep topcoats of paint in good condition;</p> <p>Selectively remove paint from friction & chewable surfaces (sills) and repaint;</p> <p>Use good quality latex, latex acrylic or oil/alkyd paints compatible with existing paint;</p> <p>Consider more durable encapsulating paints and wall lining systems if necessary.</p>	<p>Add bark mulch, sod or topsoil to bare dirt areas with high lead levels;</p> <p>Discourage children from playing in these areas by providing sand box or other safe areas;</p> <p>Do not plant vegetable garden in areas with lead in soil;</p> <p>Be careful that pets do not track contaminated soil inside house.</p>	<p>Notify tenants and workers as to the location of lead-based paint;</p> <p>Instruct tenants to keep property clean;</p> <p>Instruct tenants to notify owner or manager when repairs are necessary;</p> <p>Provide tenants with health department pamphlets on the hazards of lead-based paint.</p>

Hazard abatement removes the hazard - not necessarily all the paint or the feature, and may include:

Paint removal	Paint Encapsulation Enclosure	Replace deteriorated elements	Soil treatment	Compliance
<p>Remove deteriorated paint or paint on friction, chewable, or impact surfaces to sound layer, repaint;</p> <p>Consider using the gentlest means possible to remove paint to avoid damage to substrate: wet sanding, low level heat guns, chemical strippers, or HEPA sanding;</p> <p>Send easily removable items (shutters, doors) off-site for paint stripping, then reinstall and paint.</p>	<p>Consider encapsulating paints with 20 years warranty to seal-in older paint; or use in combination with wall liners to stabilize plaster wall surfaces prior to repainting;</p> <p>Seal lead-based painted surfaces behind rigid enclosures, such as drywall, or use luan or plywood with new coverings over previously painted floors;</p> <p>Use rubber stair treads on painted steps.</p>	<p>Remove, only when necessary, seriously deteriorated painted elements such as windows, doors, and trimwork. Replace with new elements that match the historic in appearance, detailing, and materials, when possible;</p> <p>Replace component element of a friction surface (parting bead or stops of windows) or of impact surfaces (shoe moldings) with new elements.</p>	<p>Remove contaminated soil around foundation to a depth of 3" and replace with new soil and appropriate planting material or paving;</p> <p>If site is highly contaminated from other lead sources (smelter, sandblasted water tank) consult an environmental specialist as well as a landscape architect;</p> <p>Do not alter a significant historic landscape</p>	<p>Be aware of all federal, state and local laws regarding lead-based paint abatement, environmental controls and worker safety;</p> <p>Dispose of all hazardous waste according to applicable laws;</p> <p>Be aware that methods to remove lead-based paint can cause differing amounts of lead dust which can be dangerous to workers and residents.</p>

Figure 13. This chart indicates the wide variety of treatments that can be used to control or eliminate lead-based paint hazards. For historic buildings, the least invasive method should be used to control the hazards identified during a risk assessment and are shown in the lighter shaded portion of the chart. The darker portions show the more invasive hazard control methods which must be carefully implemented to ensure that whenever possible, historic materials are protected. The total abatement of all surfaces is not recommended for historic buildings because it can damage historic materials and destroy the evidence of early paint colors and layering. Prepared by Sharon C. Park, AIA.

IMPACT OF VARIOUS PAINT REMOVAL/ABATEMENT TECHNIQUES

REMOVAL METHOD	IMPACT ON MATERIALS	LEAD DUST GENERATED	IMPACT ON WORKER	IMPACT ON ENVIRONMENT
Wet scraping; wet sanding; repainting	Low: Gentle to substrate; feather edges to obtain smooth paint surface	Low: Misting surfaces reduces lead dust	Low: No special protection for respiration, but wash before eating, drinking, etc.	Low-medium: Debris often general waste; check disposal requirements
Heat gun; paint removal w/ scrapers < 450°F	Low: Gentle to substrate	Medium: Flicking softened paint does create airborne lead dust	Medium: Respirator w/HEPA filters usually required	Medium: Lead-paint sludge is hazardous waste
Chemical stripping on-site; use liquid or poultice; avoid methylene chloride	Low to Medium: Avoid damage to wood texture/grain with long dwell time	Low: Chemicals are moist and reduce lead dust	Low: For lead dust; for volatile chemicals may require solvent filter mask	Medium: Lead residue hazardous; off/rinse must be filtered or contained
Controlled HEPA sanding; primarily for wooden surfaces; sander uses HEPA vacuum shroud	Low to Medium: Avoid gouging wooden surfaces; good for feathering edges	Medium to High: Worker must know how to use equipment	Medium to High: Requires respirator with HEPA filter and possibly containment of area	Medium to High: Paint debris is hazardous and must be contained in drums for disposal
Dry Abrasives on cast iron; CO ₂ , walnut shells, needle gun removal; can use vacuum shrouds	Low to Medium: Substrate must be durable and in good condition; not for soft or porous materials	Generally High: Large volume of paint chips fall freely unless there is a vacuum shroud	High; Generally requires full suiting, respirators and containment, even if vacuum shroud used	Medium to High: Increased volume of hazardous waste if abrasive is added to lead debris
Chemical stripping off-site; cold tank reduces ungluing caused by hot tank	Medium to High: Elements can be damaged during removal or in tank	Usually low: Take care when removing elements to minimize lead-laden dust	Low: Take care when washing up to remove dust; wash clothes separately	Low to Medium: Stripping contractor responsible for disposal
Feature or substrate removal and replacement	High: Loss of feature is irretrievable; Avoid wholesale removal of significant elements	Usually low: Worker exposure can be high if element hazardous due to high amounts of lead-based paint	Usually low: Varies with lead dust generated; use air monitors and wet mist area	Varies: Must do a TCLP leach test to determine if debris can go to landfill or is hazardous waste

Figure 14. This chart shows how the impact of lead hazard control work can impact a property. The painting or hazard removal methods, shaded from light to dark, are listed from low to medium to high impact on various materials. Each method will generate a varying amount of lead dust and hazardous materials; the impact on workers and the environment will thus vary accordingly. This information gives a general overview and is not a substitute for careful air monitoring and compliance with worker protection as established by OSHA regulations, and the proper handling/disposal of hazardous waste. Prepared by Sharon C. Park, AIA.

examples of appropriate methods to use to control lead hazards within an historic preservation context.

Historic Interiors (deteriorating paint and chewed surfaces). Whenever lead-based paint (or lead-free paint covering older painted surfaces) begins to peel, chip, craze, or otherwise comes loose, it should be removed to a sound substrate and the surface repainted. If children are present and there is evidence of painted surfaces that have been chewed, such as a window sill, then these surfaces should be stripped to bare wood and repainted. The removal of peeling, flaking, chalking, and deteriorating paint may be of a small scale and undertaken by the owner, or may be extensive enough to require a paint contractor. In either case, care must be taken to avoid spreading lead dust throughout the dwelling unit. If the paint failure is extensive and the dwelling unit requires more permanent hazard removal, then an abatement contractor should be considered. Many states are now requiring that this work be undertaken by specially trained and certified workers.

If an owner undertakes interim controls, it would be advisable to receive specialized training in handling lead-based paint. Such training emphasizes isolating the area, putting plastic sheeting down to catch debris, turning off mechanical systems, taping registers closed, and taking precautions to clean up prior to handling food. Work clothes should be washed separately from regular family laundry. The preferred method for removing flaking paint is the wet sanding of surfaces because it is gentle to the substrate and controls lead dust. The key to reducing lead hazards while stabilizing flaking paint is to keep the surfaces slightly damp to avoid ingesting lead dust. Wet sanding uses special flexible sanding blocks or papers that can be rinsed in water or used along with a bottle mister. This method will generally not create enough debris to constitute hazardous waste (see fig. 15).

Other methods for selectively removing more deteriorated paint in historic housing include controlled sanding, using low-temperature heat guns, or chemical strippers. Standard safety precautions and appropriate worker protection should be used. Methods to *avoid* include uncontrolled dry abrasive methods, high heat removal (lead vaporizes at 1100° F), uncontrolled water blasting, and some chemicals considered carcinogenic (methylene chloride). When possible and practicable, painted elements, such as

radiators, doors, shutters, or other easily removable items, can be taken to an off site location for paint removal.

In most cases, when interior surfaces are repainted, good quality interior latex or oil/alkyd paints may be used. The paint and primer system must be compatible with the substrate, as well as any remaining, well-bonded, paint.

Encapsulant paints and coatings, developed to contain lead-based paint, rely on an adhesive bonding of the new paint through the layers of the existing paint. The advantages of these special paint coatings is that they allow the historic substrate to remain in-place; reduce the amount of existing paint removed; can generally be applied without extensive worker protection; and are a durable finish. (They cannot, however, be used on friction surfaces.) The drawbacks include their ability to obscure carved details, unless thinly applied in several applications, and difficulty in future removal. If a specialized paint, such as an elastomeric encapsulant paint, is considered, the manufacturer should be contacted for specific instructions for its application. Unless these specialized paint systems are warranted for 20 years, they are considered as less permanent interim controls.

Lead-dust on interior finishes. Maintaining and washing painted surfaces is one of the most effective measures to prevent lead poisoning. Houses kept in a clean condition, with paint film intact and topcoated with lead-free paint or varnish, may not even pose a health risk. Dust wipe tests, which are sent to a laboratory for processing, can identify the level of lead dust present on floors, window sills, and window troughs. If lead dust is above acceptable levels, then specially modified maintenance procedures can be undertaken to reduce it. All paints deteriorate over time, so maintenance must be ongoing to control fine lead dust. The periodic washing of surfaces with a surfactant, such as tri-sodium phosphate (TSP) or its equivalent, loosens dirt and removes lead dust prior to a water rinse and touch-up painting, if necessary. This interim treatment can be extremely beneficial in controlling lead dust that is posing a hazard (see fig. 16).

Soil/landscape. Soil around building foundations may contain a high level of lead from years of chalking and peeling exterior paint. This dirt can be brought indoors on shoes or by pets and small children if they play outside a house. Lead in the soil is generally found in a narrow band



Figure 15. Wet sanding of interior surfaces will keep dust levels down, reduce the need for workers' protection, and provide a sound surface for repainting. Priming and repainting with oil/alkyd, latex or latex acrylic should be undertaken according to manufacturers' instructions.

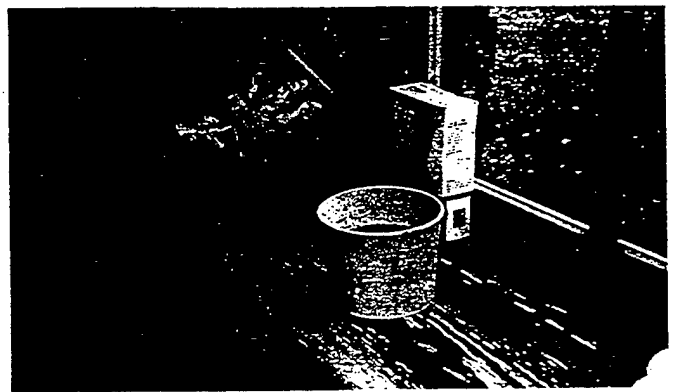

Figure 16. Washing windows and cleaning debris from window well, a periodic basis can substantially reduce lead dust. Using water and tri-sodium phosphate (TSP or equivalent) will remove loose paint, and, after rinsing, the surface can be repainted with latex, oil/alkyd, or latex acrylic paints.

directly adjacent to the foundation. If the bare soil tests high in lead (see Action Levels Chart, pg. 6), it should be replaced to a depth of several inches or covered with new sod or plantings. Care should be taken to protect historic plantings on the building site and, in particular, historic landscapes, while mitigation work is underway (see fig. 17). If an area has become contaminated due to a variety of environmental conditions (for example, a smelter nearby or water tanks that have been sandblasted in the past), then an environmental specialist as well as a landscape preservation architect should be consulted on appropriate site protection and remedial treatments. It is inappropriate to place hard surfaces, such as concrete or macadam, over historically designed landscaped areas, which is often the recommendation of typical abatement guidelines.



Figure 17. When historic sites are found to contain high levels of lead in bare soil — particularly around foundations — it is important to reduce the hazard without destroying significant landscapes. In many cases, contaminated soil can be removed from the foundation area and appropriate plantings or ground covers replanted in new soil. Photo: Charles A. Birnbaum, ASLA.

Deteriorating paint on exteriors. Deteriorating exterior paint will settle onto window ledges and be blown into the dwelling, and will also contaminate soil at the foundation, as previously discussed. Painted exteriors may include wall surfaces, porches, roof trim and brackets, cornices, dormers, and window surrounds. Most exteriors need repainting every 5-10 years due to the cumulative effect of sun, wind, and rain or lack of maintenance. Methods of paint removal that do not abrade or damage the exterior materials should be evaluated. Because there is often more than one material (for example, painted brick and galvanized roof ornaments), the types of paint removal or paint stabilization systems need to be compatible with each material (see fig. 18). If paint has failed down to the substrate, it should be removed using either controlled sanding/scraping, controlled light abrasives for cast iron and durable metals, chemicals, or low heat. If chemicals are used, it may be necessary to have the contractor contain, filter, or otherwise treat any residue or rinse water. Environmental regulations must be checked prior to work, particularly if a large amount of lead waste will be generated or public water systems affected.

A cost analysis may show that, in the long run, repair and maintenance of historic materials or in-kind replacement can be cost effective. Due to the physical condition and location of wood siding, together with the cost of paint removal, a decision may be made to remove and replace



Figure 18. As part of an urban housing grant program, the exterior of this row house was successfully made lead-safe and met the Secretary of the Interior's Standards for Rehabilitation. The exterior was washed, then repainted with exterior grade alkyd paint. The decorative roof brackets and cornice were repainted; not removed or covered as is often recommended in typical abatement guidelines. The previously altered, deteriorated window sash were replaced with new sash and jamb liners set within the historic frames. Photos: Deborah Birch.

these materials on some historic frame buildings. If the repair or replacement of historic cladding on a primary elevation is being undertaken, such replacement materials should match the historic cladding in material, size, configuration, and detail (see fig. 19). The use of an artificial siding or aluminum coil stock panning systems over wooden trimwork or sills and lintels (as recommended in some abatement guidelines) is not appropriate, particularly on principal facades of historic buildings because they change the profile appearance of the exterior trimwork and may damage historic materials and detailing during installation. Unless the siding is too deteriorated to warrant repair and the cost is too prohibitive to use matching replacement materials (i.e., wood for wood), substitute materials are not recommended.

The use of specialized encapsulant paint coatings on exteriors—in particular, moist or humid climates, and, to some extent, cold climates—is discouraged because such coatings may serve to impede the movement of moisture that naturally migrates through other paints or mask leaks that may be causing substrate decay. Thus, a carefully applied exterior paint system (either oil/alkyd or latex) with periodic repainting can be very effective.

Friction Surfaces. Interior features with surfaces that—functionally—rub together such as windows and doors, or are subject to human wear and tear, such as floor and steps, are known as friction surfaces. It is unclear how much lead dust is created when friction surfaces that contain lead-based paint, but are top-coated with lead-free paint, rub together because much of the earlier paint may have worn away. For example, if lead dust levels around windows or on painted floors are consistently above acceptable levels, treating nearby friction surfaces should be considered. If surfaces, such as operable windows, operable doors, painted porch decks, painted floors and painted steps appear to be generating lead dust, they should be controlled through isolating or removing the lead-based paint. Window and door edges can be stripped or planed, or the units stripped on or off site to remove paint prior to repainting. Simple wooden stops and parting beads for windows, which often split upon removal, can be replaced.



Before



After

Figure 19. In many cases, exterior wood siding can be repaired, selectively replaced, and repainted, as illustrated in this successful residential rehabilitation. Deteriorating wood siding was removed from the foundation to the top of the first floor windows and replaced with matching wood siding. The entire building was repainted. Photos: Crispus Attucks Community Development Corporation.



Figure 20. Operable windows have friction surfaces between the sash and the frames, which can be a source of fine lead dust. In this case, the deteriorated sash was replaced, but the historic frame remains in place, successfully isolated from the sash with a simple vinyl jamb liner that is part of the new sash operation.

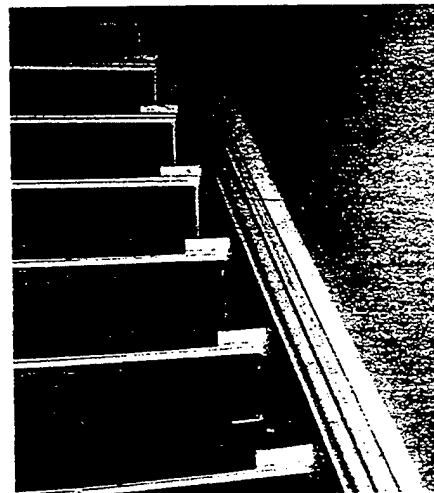

Figure 21. Painted stairs and floors can cause a problem because lead dust settles between the wooden boards. In this case, the steps were sanded, repainted, and covered with rubber stair treads. The floors could not be effectively cleaned and sealed so they were isolated with a new subflooring, and a washable tile finish installed.

If window sash are severely deteriorated, it is possible to replace them; and vinyl jamb liners can effectively isolate remaining painted window jambs (see fig. 20). When windows are being treated within rehabilitation projects, their repair and upgrading are always recommended. In the event that part or all of a window needs to be replaced, the new work should match in size, configuration, detail, and, whenever possible, material.

Painted floors often present a difficult problem because walking on them abrades the surface, releasing small particles of lead-based paint. It is difficult to remove lead dust between the cracks in previously painted strip flooring even after sanding and vacuuming using special High Efficiency Particulate Air (HEPA) filters to control the lead dust. If painted floors are not highly significant in material, design, or craftsmanship, and they cannot be adequately cleaned and refinished, then replacing or covering them with new flooring may be considered. Stair treads can be easily fitted with rubber or vinyl covers (see fig. 21).

Accessible, projecting, mouthable surfaces. Accessible, chewable surfaces that can be mouthed by small children need not be removed entirely, as some health guidelines recommend. These accessible surfaces are listed as projecting surfaces within a child's reach, including window sills, banister railings, chair rails, and door edges. In many cases, the projecting edges can have all paint removed using wet sanding, a heat gun or chemical strippers, prior to repainting the feature (see fig. 22). If the homeowner feels that there is no evidence of unsupervised mouthing of surfaces, a regular paint may be adequate once painted surfaces have been stabilized. An encapsulant paint that adhesively bonds existing paint layers onto the substrate extends durability. While encapsulant paint systems are difficult to remove from a surface in the future they permit retention of the historic feature itself. If encapsulant paint is used on molded or decorative woodwork, it should be applied in several thin coats to prevent the architectural detail from being obscured by the heavy paint (see fig 23).



Figure 22. Research has shown that some small children will chew on projecting window sills while teething. As part of a lead hazard control project, the edge of the sill can be stripped to bare wood or an encapsulating paint applied. In this case, a new window sill was installed as part of a window upgrade that retained the historic trim and frame.

Figure 23. Stair banisters and railings are considered mouthable surfaces. In this case, the old paint was wet sanded to a sound layer. Special encapsulant paints were then applied in three thin layers to avoid obscuring the woodwork's fine detailing. It should be noted that many encapsulant paints are now treated with a bitter agent to discourage mouth contact. Photo: Landmarks Design Associates.

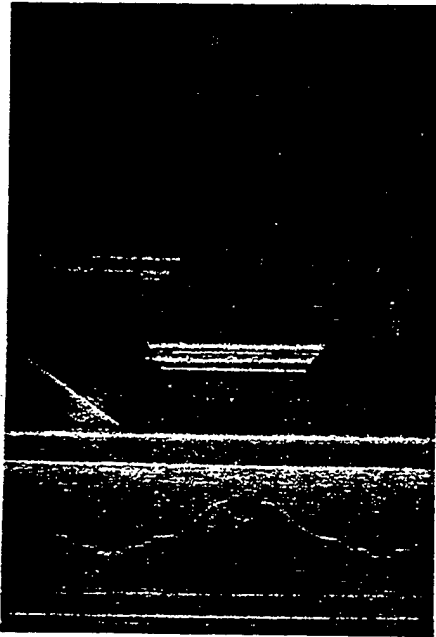

Impact Surfaces. Painted surfaces near doorways and along corridors tend to become chipped and scraped simply because of their location. This is particularly true of baseboards, which were designed to protect wall surfaces, and also for doorjamb. Owners should avoid hitting painted impact surfaces with vacuums, brooms, baby carriages, or wheeled toys. Adding new shoe moldings can give greater protection to some baseboards. In most cases, stabilizing loose paint and repainting with a high quality interior paint will provide a durable surface. Clear panels or shields can be installed at narrow doorways, if abrasion continues, or these areas can be stripped of paint and repainted. Features in poor condition may need to be replaced with new, matching materials (see fig. 24).

Other surfaces showing age or deterioration/ walls and ceilings. Many flat wall surfaces and ceilings were not painted with lead-based paint, so will need to be tested for its presence prior to any treatment. Flat surfaces that contain deteriorating lead-based paint should be repaired following the responsible approach previously cited (i.e., removing loose paint to a sound substrate, then repairing damaged plaster using a skim coat or wet plaster repair (see fig. 25). Drywall is used *only* when deterioration is too great to warrant plaster repair. If walls and ceilings have a high lead content, and extensive paint removal is not feasible, there are systems available that use elastomeric paints with special fabric liners to stabilize older, though intact, wall surfaces.



Figure 24. Historic baseboards are often bumped by brooms and vacuum cleaners, causing lead-based paint chips to fall on the floor. Shoe moldings can be added or replaced to increase protection to the baseboard itself. In this case, because the condition of the interior warranted substantial repair, simple historic board trim was replaced with new matching trim. Note the HEPA filter vacuum in the foreground. Photo: NPS file.

Figure 25. In some cases, skim coating deteriorated plaster and repainting is adequate. If the plaster is seriously damaged or failing, drywall may be considered so long as the molding and window reveal relationships are retained. In this case, plaster between the windows was repaired and repainted and the side wall plaster was replaced with drywall. Photo: Landmarks Design Associates.

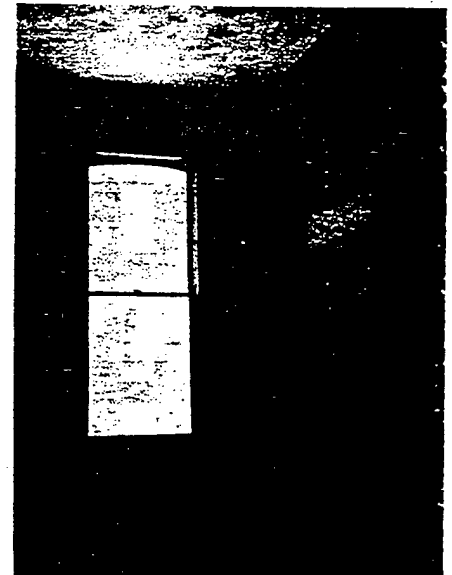

If a new drywall surface needs to be applied, care should be taken that the historic relationship of wall to trim is not lost. Also, if there are significant features, such as crown moldings or ceiling medallions, they should always be retained and repaired (see fig. 26).



Figure 26. Deteriorated ceiling plaster was removed and a new drywall ceiling installed. The historic ceiling medallion was preserved, and the plaster cornices repaired in place. Photo: Landmarks Design Associates.

Maintenance after Hazard Control Treatment

Following treatment, particularly where interim controls have been used, ongoing maintenance and re-evaluation become critical. In urban areas, even fully lead-safe houses can be re-contaminated within a year from lead or dirt outside the immediate property. Thus, housing interiors must be kept clean, once lead hazard control measures have been implemented. Dust levels should be kept down by wet sweeping porch steps and entrances on a regular basis. Vacuum cleaning and dusting should be repeated inside on a weekly basis or even more often. Vinyl, tile, and wood floor surfaces should be similarly damp mopped. Damp washing of window troughs and sills to remove new dust should be encouraged several times a year, particularly in the spring and fall when windows will be open. Carpets and area rugs should be steam cleaned or washed periodically if they appear to hold outside dirt.

Housing should be inspected frequently for signs of deterioration by both owner and occupant. Tenants need to be made aware of the location of lead-based paint under lead-free top coats and instructed to contact the owners or property managers when the paint film becomes disturbed (see figure 27). Any leaks, peeling paint, or evidence of

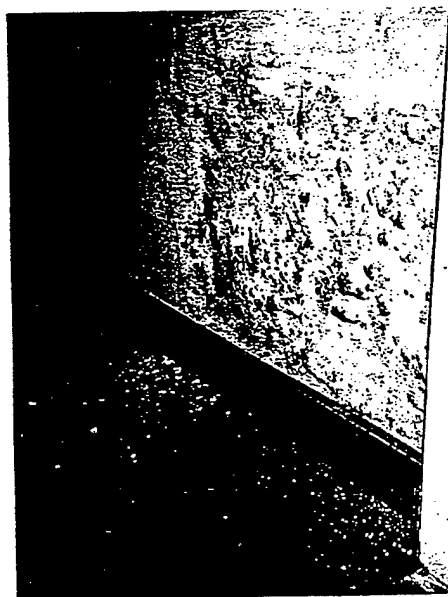

Figure 27. Wall leaks can cause historic surfaces to deteriorate, thereby exposing underlayers of lead-based paint. If painted surfaces show signs of deterioration, they should be repaired as soon as possible.

conditions that may generate lead-dust should be identified and corrected immediately. Occupants must be notified prior to any major dust-producing project. Dry sanding, burning, compressed air cleaning or blasting should be not be used. Repairs, repainting, or remodeling activities that have the potential of raising significant amounts of lead dust should be undertaken in ways that isolate the area, reduce lead-laden dust as much as possible, and protect the occupants.

Yearly dust wipe tests are recommended to ensure that dust levels remain below actionable levels. Houses or dwelling units that fail the dust-wipe test should be thoroughly re-cleaned with TSP, or its equivalent, washed down, wet vacuumed and followed by HEPA vacuuming, if necessary, until a clearance dust wipe test shows the area to be under actionable levels (see Action Levels chart). Spaces that are thoroughly cleaned and maintained in good condition are not a health risk (see fig. 28).

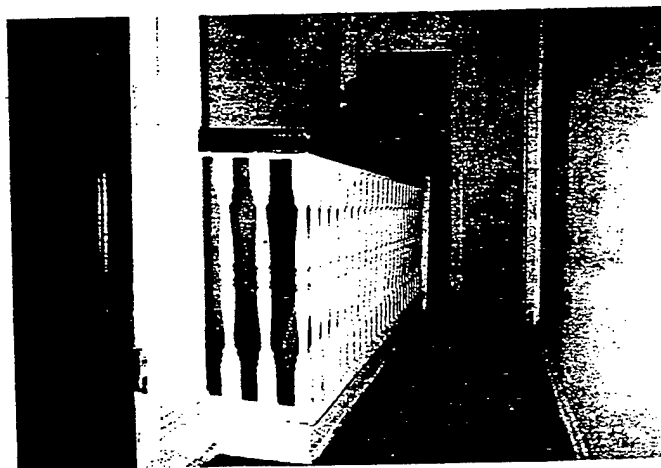

Figure 28. This recently completed housing, which is now lead-safe, could become re-contaminated from lead if safe conditions are not maintained. Damp mopping floor surfaces and regular dusting to keep the house clean will ensure its continuing safety.

Conclusion

The three-step planning process outlined in this Brief provides owners and managers of historic housing with responsible methods for protecting historic paint layers and architectural elements, such as windows, trimwork, and decorative finishes. Exposed decorative finishes, such as painted murals or grained doors can be stabilized by a paint conservator without destroying their significance.

Reducing and controlling lead hazards can be successfully accomplished without destroying the character-defining features and finishes of historic buildings. Federal and state laws generally support the reasonable control of lead-based paint hazards through a variety of treatments, ranging from modified maintenance to selective substrate removal. The key to protecting children, workers, and the environment is to be informed about the hazards of lead, to control exposure to lead dust and lead in soil, and to follow existing regulations. In all cases, methods that control lead hazards should be selected that minimize the impact to historic resources while ensuring that housing is lead-safe for children.

LEAD-BASED PAINT LEGISLATION

The following summarizes several important regulations that affect lead-hazard reduction projects. Owner's should be aware that regulations change and they have a responsibility to check state and local ordinances as well.

Federal Legislation:

Title X (Ten) Residential Lead-Based Paint Hazard Reduction Act of 1992 is part of the Housing and Community Development Act of 1992 (Public Law 102-550). It established that HUD issue "The Guidelines for the Evaluation and Control of Lead-Based Paint Hazards in Housing" (1995) to outline risk assessments, interim controls, and abatement of lead-based paint hazards in housing. Title X calls for the reduction of lead in housing that is *federally supported* and outlines the federal responsibility towards its own residential units and the need for disclosure of lead in residences, even private residences, prior to sale.

Interim Final Regulations of Lead in Construction Standards (29CFR 1926.62). Issued by the Department of Labor, Occupational Safety and Health Administration (OSHA), these regulations address worker safety, training, and protective measures. It is based in part on environmental air sampling to determine the amount of lead dust generated by various activities.

Toxic Substance Control Act; Title IV. The Environmental Protective Agency (EPA) has jurisdiction for setting standards for lead abatement. Also, EPA controls the handling and disposal of hazardous waste generated during an abatement project. EPA will develop standards to establish lead hazards, to certify abatement contractors, and to establish work practice standards for abatement activity. EPA Regional Offices can provide guidance on the appropriate regulatory agency for states within their region.

State Laws: States generally have the authority to regulate the removal and transportation of lead based paint and the generated waste generally through the appropriate

state environmental and public health agencies. Most requirements are for mitigation in the case of a lead-poisoned child, or for protection of children, or for oversight to ensure the safe handling and disposal of lead waste. When undertaking a lead-based paint reduction program, it is important to determine which laws are in place that may affect your project. Call the appropriate officials.

Local Ordinances: Check with local health departments, Poison Control Centers, and offices of housing and community development to determine if there are laws that require compliance by building owners. Rarely are owners required to remove lead-based paint and most laws are to ensure safety if a project is undertaken as part of a larger rehabilitation. Special use permits may be required when an environmental impact may occur due to a cleaning treatment that could contaminate water or affect water treatment. Determine whether projects are considered abatements and will require special contractors and permits.

Owner's Responsibility: Owners are ultimately responsible for ensuring that hazardous waste is properly disposed of when it is generated on their own sites. Owners should check with their state office to determine if the abatement project requires a certified contractor. (National certification requirements are not yet in place.) Owners should establish that the contractor is responsible for the safety of the crew and that all applicable laws are followed, and that transporters and disposers of hazardous waste have liability insurance as a protection for the owner. If an interim treatment is being used to reduce lead hazards, the owner should notify the contractor that lead-based paint is present and that it is the contractor's responsibility to follow appropriate work practices to protect workers and to complete a thorough clean-up to ensure that lead-laden dust is not present after the work is completed.

Glossary of Terms

Deteriorated Lead-Based Paint: Paint known to contain lead that shows signs of peeling, chipping, chalking, blistering, alligating or otherwise separating from its substrate.

Dust Removal: The process of removing dust to avoid creating a greater problem of spreading lead particles; usually through wet or damp collection or through the use of special HEPA vacuums.

Hazard Abatement: Long-term measures to remove the hazards of lead-based paint through selective paint stripping of deteriorated areas; or, in some cases, replacement of deteriorated features.

Hazard Control: Measures to reduce lead hazards to make housing safe for young children. Can be accomplished with interim (short-term) or hazard abatement (long-term) controls.

Interim Control: Short-term methods to remove lead dust, stabilize deteriorating surfaces, and repaint surfaces. Maintenance can ensure that housing remains lead-safe.

Lead-based Paint: Any existing paint, varnish, shellac or other coating that is in excess of 1.0 mg/cm² as measured by an XRF detector or greater than 0.5% by weight from laboratory analysis (5,000 ppm, 5,000 ug/g, or 5,000 mg/kg). For new products, the Consumer Safety Act notes 0.06% as the maximum amount of lead allowed in paint.

Lead-safe: The act of making a property safe from contamination by lead-based paint, lead-dust, and lead in soil generally through short and long-term methods to remove it, or to isolate it from small children.

Risk Assessment: An on-site investigation to determine the presence and condition of lead-based paint, including limited test samples, and an evaluation of the age, condition, housekeeping practices, and uses of a residence.

Further Reading

Chase, Sara B. *Preservation Brief 28: Painting Historic Interiors*. Washington, DC: US Department of the Interior, National Park Service, 1992.

"Coping with Contamination: A Primer for Preservationist," *Information; Booklet No. 70*. Washington, DC: National Trust for Historic Preservation, 1993.

Historic Buildings and the Lead Paint Hazard. Hartford, CT: Connecticut Historical Commission, 1990.

"Health Hazards in National Park Service Buildings", *NPS-76 Housing Design and Rehabilitation*. Washington DC: US Department of the Interior, National Park Service, 1995.

Guidelines for the Evaluation and Control of Lead-Based Paint Hazards in Housing. Washington, DC: US Department of Housing and Urban Development, 1995.

Jandl, H. Ward. *Preservation Brief 18: Rehabilitating Historic Interiors - Identifying and Preserving Character-defining Elements*. Washington, DC: US Department of the Interior, National Park Service, 1988.

MacDonald, Marylee. "Getting Rid of Lead." *Old House Journal*, July/Aug 1992.

Myers, John H. *Preservation Briefs 9; Repair of Historic Wooden Windows*. Washington, DC: US Department of the Interior, National Park Service, 1981.

OSHA Lead in Construction Standard (29 CFR 1926.62), Occupational Safety and Health Administration, May 4, 1993 (Federal Register).

Park, Sharon C. and Camille Martone. "Lead-Based Paint in Historic Buildings," *CRM Bulletin*. Washington, DC: US Department of the Interior, National Park Service. Vol. 13, No. 1, 1990.

Park, Sharon C. "Managing Lead in Building Interiors: An Emerging Approach," *Interiors Handbook for Historic Buildings, Vol. II*. Washington DC: Historic Preservation Education Foundation, 1993.

Park, Sharon C. "What to do about Lead-Based Paint," *CRM Bulletin*. Washington, DC: U.S. Department of the Interior, National Park Service. Vol. 17, No. 4, 1994.

The Secretary of the Interior's Standards for the Treatment of Historic Properties. Washington, DC: US Department of the Interior, National Park Service, 1992.

Title X (Residential Lead-Based Paint Hazard Reduction Act of 1992) of Housing and Community Development Act of 1992 (P.L. 102-550), October 28, 1992.

Weeks, Kay D. and David Look, AIA. *Preservation Briefs 10; Exterior Paint Problems on Historic Woodwork*. Washington DC: US Department of the Interior, National Park Service. 1982.

This successfully completed project combined federal low income housing and historic preservation tax credits as part of a substantial rehabilitation that applied lead-hazard reduction methods consistent with the guidance in this Preservation Brief. Photo: Landmarks Design Associates.



Photographs courtesy of the authors unless identified.

Front cover: Most residences painted prior to 1978 will contain some lead-based paint. It was widely used on exterior woodwork, siding, and windows as well as interior finishes. This apartment stairhall retains its historic character after a successful rehabilitation project that included work to control lead-based paint hazards. Photo: Crispus Attucks Community Development Corporation.

Acknowledgements

Sharon C. Park, AIA, is the Senior Historical Architect for the Preservation Assistance Division of the National Park Service. Douglas C. Hicks is the Deputy Chief of the Williamsport Preservation Training Center of the National Park Service. Both authors served on the National Park Service Housing Task Force addressing lead-safe employee housing and on various national panels to discuss combining lead-safe housing, worker safety, and historic preservation concerns.

Kay D. Weeks was technical editor for this publication project. The project was completed under the direction of H. Ward Jandl, Deputy Chief, Preservation Assistance Division. The authors also wish to thank the following individuals for providing technical information or for supplying case study projects: Claudia Kavenagh, Building Conservation Associates, Inc; David E. Jacobs, Armand C. Magnelli, National Center for Lead-Safe Housing; Ellis Goldman, William Wisner, and Catherine Hillard, HUD Office of Lead-Based Paint Abatement; Ellis Schmidlapp, Landmarks Design Associates (Pittsburg, PA); Crispus Attucks Community Development Corporation (York, PA); Charlene Dwin Vaughn and Rebecca Rogers, the Advisory Council on Historic Preservation; George Siekkinen, National Trust for Historic Preservation; Deborah Birch, Einhorn Yaffee Prescott Architects; Baird M. Smith and Quinn Evans Architects; Jack

Waite, Messick Cohen Waite Architects; Jim Caufield, Pennsylvania Historical and Museum Commission; Mike Jackson, Illinois Historic Preservation; Martha Raymond, Ohio Historic Preservation Division; Susan Chandler, Connecticut Historic Commission; Steade Craig, California Office of Historic Preservation; Christopher Jones, Rocky Mountain Regional Office, NPS; Rebecca Shiffer and Kathleen Catalano Milley, Mid-Atlantic Regional Office, NPS; Peggy Albee, North Atlantic Regional Office, Cultural Resources Center, NPS; Victoria Jacobson, AIA, Mt. Rainier National Park; E. Blaine Cliver, Anne E. Grimmer, Thomas C. Jester, Michael J. Auer, Charles A. Birnbaum, ASLA, and Charles E. Fisher of the Preservation Assistance Division, the National Park Service, and Thomas McGrath, Williamsport Preservation Training Center.

This publication has been prepared pursuant to the National Historic Preservation Act of 1966, as amended, which directs the Secretary of the Interior to develop and make available information concerning historic properties. Comments about this publication should be directed to the Preservation Assistance Division, National Park Service, PO Box 37127, Washington, DC 20013-7127. This publication is not copyrighted and can be reproduced without penalty. Normal procedures for credit to the authors and the National Park Service are appreciated.

SOURCE LIST FOR ADDITIONAL INFORMATION OLD HOSPITAL COMPLEX, FORT CARSON

Colorado Historic Preservation Office, 1300 Broadway, Denver, Colorado, 80203. (303) 866-3035. The CHPO can provide recommendations for the repair, maintenance, restoration, or reconstruction of historic elements, and the design of handicapped accessible new features.

Fire Safety Retrofitting in Historic Buildings. Advisory Council on Historic Preservation, and General Services Administration. 1989. This book offers recommendations for installing systems that maintain safety and property integrity while preserving distinct historic features.

Historic Materials Source Book for Army Family Housing. Technical Center of Expertise for Preservation of Historic Structures and Buildings, US Army Corps of Engineers. nd. This book provides a catalog of historic construction materials and services available for the preservation of cultural resources. The book is organized by CSI Division and includes a Suppliers Index listing companies by state.

Old Hospital Complex (5EP1778) Fort Carson, Colorado. Connor, Melissa and Schneck, James. 1996. National Park Service, Midwest Archeological Center, Lincoln, Nebraska. (402) 437-5392. This document contains a general history of World War II military construction and HABS level II documentation of all World War II era Old Hospital Complex buildings.

Preservation Briefs. US Department of the Interior, National Park Service. The briefs are short case studies of preservation methods and philosophy and contain references for further study. Relevant briefs are included in this manual.

Preservation Tech Notes. US Department of the Interior, National Park Service. Tech Notes provide practical information on innovative techniques and practices for successfully maintaining and preserving cultural resources. Relevant briefs are included in this manual.

Preservation Technology Source Book. This publication contains reference sources and articles regarding the maintenance and preservation of historic materials; organized by CSI Division.

Technical Manual TM 5-801-1 Historic Preservation; Administrative Procedures, DoA, 1975. This military publication discusses surveys, evaluation, documentation and nomination procedures, and identifies process for establishing a preservation program.

Technical Manual TM 5-801-2 Historic Preservation: Maintenance Procedures, DoA, 1977. This military publication provides a general outline of considerations for the maintenance of historic buildings, some typical maintenance problems, and some accompanying potential repair solutions.

The Rocky Mountain Masonry Institute, 1780 South Bellaire, Suite 402, Denver, Colorado, 80222. (303) 691-2141. The RMMI maintains lists of local, regional, and national civic and professional organizations that produce, supply, support, install, maintain, and test masonry products.

MANAGEMENT AND MAINTENANCE PLAN BUILDING S6237, OLD HOSPITAL COMPLEX, FORT CARSON

OVERVIEW

The Old Hospital Complex (OHC) is culturally significant within American history for its association with the United States' victory in World War II.

This Management and Maintenance Plan is based upon the Secretary of the Interior's Standards and Guidelines for Restoring Historic Buildings. A list of general requirements relevant to all aspects of building maintenance introduces the plan. These general requirements are followed by a series of divisions organized according to Construction Specifications Institute standard format. Each division contains a list of character-defining features; guidelines for restoration, repair, rehabilitation, or replacement; and general specifications for new materials. Data in these divisions are derived from remaining original building fabric, the original 800 Series US Army Corps of Engineers plans and records of modifications, building codes for conservation of historic buildings, and life safety codes for existing business occupancies.

The plan is accompanied by a Historic Building Management Record, a Cyclic Maintenance Schedule, and a Cyclic Maintenance Checklist. The maintenance of historic buildings is an ongoing and dynamic process. The Maintenance and Management Plan must therefore be flexible to meet new and changing building requirements, methods of management, and technologies. The establishment of a Maintenance Checklist, Cyclic Maintenance Schedule, and an accompanying Management Record is necessary to insure consistent and informed care of buildings over time.

Recommended cycle of care:

- | | | |
|--------------------|---|--|
| observe and assess | - | be vigilant for problems or potential problems |
| plan | - | refer to the building or complex Management Record for treatment alternatives |
| treat | - | use the Secretary's Guidelines discussed in this Plan |
| evaluate | - | record action and success in Management Records, and in Real Property Records and Historical Repair Work List. |

GENERAL REQUIREMENTS FOR MAINTENANCE

Simple functionality is the dominating characteristic of this building. The character-defining features of the building's interior are the simple, functional layouts of narrow rooms flanking double-loaded corridors, and the standardized, off-the-shelf components. The building's exterior is defined by its low, symmetrical appearance, the simple and repetitive door and window openings, and the intersection of walkway corridors at the building's center.

Character-defining features, including original building materials, should be maintained and preserved whenever possible. If original material is missing, non-original, or damaged beyond repair, every effort should be made to replace the damaged material using salvage from adjacent World War II era 800 Series buildings to be demolished. Historic materials may also be relocated from less conspicuous areas of a building to prominent areas more visible to public view. Care should be taken to protect surrounding historic features during such repair or replacement.

Project specifications should refer, and require all new work to conform, to original 800 Series plans and specifications, Technical Preservation Services Division Preservation Briefs, National Park Service Technical Notes, and the Advisory Council on Historic Preservation's Fire Safety Retrofitting in Historic Buildings.

All proposals should be submitted to the Government for review and approval. All work should be carried out by competent personnel trained both in the care of historic features and in the proper application of new or replacement materials. Current source material for the treatment of typical OHC buildings is included in the Reading List. All work should be documented on the Historical Repair Work List (listed in the Directorate of Public Works Base Operations Division blanket contract) and Historic Building Management Record.

Reference should be made to the Historic Building Management Record for previous methods of care prior to any action. Established and successful methods should be used whenever possible. New processes and products should be applied according to manufacturer's specifications and should be tested on less visible surfaces or non-historic buildings before applying on a widespread basis. The short term benefits of proposed actions should always be compared against the long term goal of preserving the historic materials.

This management guideline and project specifications should be modified with the results of additional documentary research regarding original historic elements or features of the OHC.

HISTORY OF BUILDING S6237

Building S6237 has been heavily altered since its completion in 1942. Its most visible alteration occurred with the construction of a 682-ft², one-story addition to the building's west facade. Additional alterations include the replacement of original windows, many doors, roofing, interior lighting, and electrical wiring.

The building's interior has also been altered. A pharmacy was established on the first floor by 1951. In 1952, the building's north end was converted to various examination rooms. In 1959, the building's first floor was converted to an OBGYN clinic. In 1960, a general surgical clinic was also established on the first floor. In 1963, all hot and cold water piping was replaced with copper.

The building's attic has been insulated and its interior and exterior surfaces have been painted, sometimes several times. The building's shingles were replaced in 1960 and around 1986. The steam heating system has been slightly modified, though its appearance remains intact. Many patient rooms were modified in 1977. These modifications included the installation of additional plumbing, new floor, wall and ceiling finishes, and replacement doors. Several additional rooms were similarly modified when the building was converted to office space in late 1992.

SUMMARY OF THE SECRETARY OF THE INTERIOR'S STANDARDS FOR RESTORATION

The Secretary of the Interior's Standards and Guidelines for Restoring Historic Buildings are listed in their entirety in this manual. The ten standards for restoration, when applied to Building S6237, require: that the building be reutilized in a manner reflective of its role during World War II; that the building's original materials, appearance, construction, detailing, and physical layout be retained as much as is practicable; that maintenance, repair, or replacement be carried out such that the work is outwardly indistinguishable from the original, yet clearly identified as modern work upon close inspection; and that extreme care be taken so that custodial or routine maintenance work not damage the building.

All building elements known to be original to the building should be preserved if in excellent and original condition. If altered, they should be sensitively restored to original condition. If restoration is not feasible, the elements should be replaced with a similar element that appears historic and maintains the visual continuity of the building. If missing, elements may be reconstructed but should appear as if original.

Character-Defining Features, Management Guidelines,
and General Specifications

Notes for Management Guidelines:

Protection and Maintenance refers to the protection and management of original material.

Repair refers to the repair of original material.

Replacement refers to the replacement of heavily damaged, missing, and non-original materials.

CONCRETE: Character-Defining Features

Foundation

- ◆ Smooth, painted surface with visible impressions of wood forms made of rough-sawn boards
- ◆ Foundation profile flush with cinder block wall
- ◆ Foundation vents at regular intervals
- ◆ Crawlspace hatches at gable ends

Original Stair Piers

- ◆ Smooth, painted surface
- ◆ Rectangular shape
- ◆ Slab exposed to seven inches above grade

CONCRETE Management Guidelines

Recommended

Protection and Maintenance

Provide proper drainage so water does not stand or accumulate.

Clean walls only when necessary to halt deterioration or remove heavy soiling. Chemical cleaning, if utilized, should be conducted by experienced professionals.

Tests should be conducted to determine the gentlest effective cleaning method possible, e.g., hand-washing or low- to medium-pressure water cleaning. Tests should be observed over a sufficient period of time so that both the immediate and the long-range effects are known.

Remove damaged, deteriorated paint only to the next sound layer. Remove hazardous paint completely. Paint removal methods shall utilize the gentlest means possible. The texture of the concrete should be preserved to the greatest extent possible.

Apply specification-approved primer and paint following proper surface preparation and product instructions.

Repair

Repair any cracks in concrete by sealing with specification-approved sealant.*

Patch damaged sections with in-kind material finished to match existing.*

Replacement

Repair damaged concrete too deteriorated to patch by cutting damaged material back to remove the source of deterioration (often corrosion of metal reinforcement bars). New patch must be applied with in-kind material finished to match existing.*

Replace sections too deteriorated to repair using materials compatible with the original materials.**

Not Recommended

Protection and Maintenance

Applying non-specified paint or other coatings such as stucco or insulation.

Introducing new or non-specified brands of paint, colors, or methods of application.

Cleaning surfaces not heavily soiled.

Cleaning without testing or without sufficient time for testing results to be of value.

Sandblasting using dry or wet grit or other abrasive agent, high-pressure waterblasting, or caustic solutions. These methods of cleaning or paint removal may permanently erode the foundation surface and accelerate deterioration.

Wet-cleaning when there is any possibility of freezing temperatures.

Repair

Replacing or rebuilding a major portion of foundation wall that could be repaired.

Patching concrete without removing the source of deterioration.

Patching with substitute material that is physically or chemically incompatible with the original concrete.

* Work shall not be initiated without approval of the Colorado Historic Preservation Office (303) 866-3398.

** Work shall not be initiated without approval of the Directorate of Environmental Compliance and Management (719) 526-4652.

General Specifications

Replacement concrete should be mixed to ASTM standards that match the hardness, composition, and appearance of the original concrete.

Paint should be a vapor-permeable, cement-based mixture capable of adhering to the stripped concrete surface, with color and finish to match wall surface.

MASONRY: Character-Defining Features

- ◆ Visible pattern of cinder block and flush tooled mortar
- ◆ Sharp building corners
- ◆ Rough texture of the cinder block face
- ◆ Wall profile flush with foundation wall
- ◆ Symmetrical pattern of original fenestration

MASONRY Management Guidelines

Recommended

Protection and Maintenance

Protect and maintain masonry elements as per management guidelines for Concrete.

Prior to repainting, at least one cinder block from a building to be demolished should be carefully stripped to its first layer of paint, then documented. The texture of this block and the characteristics of its original layer of paint, if visible, should be replicated as closely as possible on all preserved buildings. The block should be archived to facilitate future research.

Repair

Repoint disintegrated mortar, cracks in mortar joints, or loose bricks. Remove deteriorated mortar by stiff brush or hand chisel (to minimum depth of 3/4"), or by the gentlest means possible.*

- Duplicate old mortar in strength, composition, color and texture.
- Duplicate old mortar joints in width and joint profile.

Replace deteriorated or damaged cinder blocks by carefully patching, piecing-in, or otherwise reinforcing the masonry, using recognized preservation methods. Replace with salvage or in-kind material painted to match existing. Replacement work should be permanently dated in an unobtrusive location.*

Not Recommended

Protection and Maintenance

Replacing or rebuilding any portion of the masonry wall that could be repaired.

Applying non-specified paint or other coatings such as stucco or insulation.

Introducing new or non-specified brands of paint, colors, or methods of application.

Cleaning masonry surfaces not heavily soiled.

Cleaning without testing or without sufficient time for testing results to be of value.

Sandblasting using dry or wet grit or other abrasive agent, high-pressure waterblasting, or caustic solutions. These methods of cleaning or paint removal may permanently erode the wall surface and accelerate deterioration.

Wet-cleaning when there is any possibility of freezing temperatures.

Repair

Replacing or rebuilding any damaged portion of the wall that could be repaired.

Removing non-deteriorated mortar from sound joints.

Repointing with mortar that is stronger than or inconsistent in porosity and texture with existing mortar.

Repointing with a synthetic caulking compound.

Changing the original width or joint profile when repointing.

Patching deteriorated masonry without removing or addressing any external sources of the deterioration, such as water dripping from eaves.

Patching with substitute materials that are physically or chemically incompatible with the original materials.

* Work shall not be initiated without approval of the Colorado Historic Preservation Office (303) 866-3398.

Recommended

Replacement

Replace major wall sections too deteriorated to repair using materials compatible with the original materials.**

Not Recommended

Replacement

Removing an original masonry feature that is unrepairable and not replacing it, or failing to label the new work.

**Work shall not be initiated without approval of the Directorate of Environmental Compliance and Management (719) 526-4652.

General Specifications

The building's cinder block walls are both strong character-defining features and vital components of the building's structural integrity. Contract specifications should require proof of experience in dealing with historic masonry. Work should be carefully overseen by professionals trained in the preservation of historic masonry.

Repointing is necessary to prevent moisture penetration of deteriorated joints. Mortar used in repointing should always be softer than the adjacent brick. Mortars with high Portland cement content should not be used. Replacement mortar should be mixed to an appropriate ASTM standard that matches the composition and appearance of the original mortar and does not exceed its hardness or the hardness of the surrounding cinder block.

Replacing missing or deteriorated block is necessary to prevent moisture penetration or animal infestation. Replacement block should always be softer than the adjacent block. Block should consist of ASTM standard cinder, coal ash, or coke block extruded to match original block in size and texture and not exceeding the hardness of the surrounding cinder block.

Paint should be a vapor-permeable, alkali-resistant, cement-based mixture capable of adhering to the deeply textured surface of the stripped or replaced cinder block and mortar. Exterior surfaces should be painted to match a Munsell Color Chart color of 'pale yellow' (2.5Y 7/4). Glidden's formula for this color is

BLK 1 P 18 YOX 3 P 51 OXR 0 P 55

Y-3600 Spred Dura Flat House Paint

Sherwin Williams' formula for this color is

BAC	COLORANT	OZ	32	64	128
Y3	Deep Gold	4	31	--	1
R2	Maroon	--	2	1	1
N1	Raw Umber	4	8	1	1
W1	White	--	21	--	1

with one gallon of Midtone Base A

A-100 Latex Flat House and Trim Paint

A compatible fill coat may be applied beneath the finish coat to smooth large voids.

METALS: Character-Defining Features

- ◆ Regularly spaced foundation vents surrounding building
- ◆ Rectangular foundation vents 8" by 12" with two columns of flutes

METALS

Management Guidelines

Recommended

Protection and Maintenance

Clean paint and corrosion using the gentlest means possible: scraping, sanding, or rubbing with a cloth imbued with mineral spirits.

Apply specification-approved primer and paint following proper surface preparation and product instructions.

Repair

Reshape bent elements.

Resecure any loose vents.

Existing non-original anchor holes on walls' exterior surface should be patched.

Replacement

Replace damaged features, missing elements, or non-original vents with salvage or in-kind material painted to match original. Replacement material should be permanently dated in an inconspicuous location.**

Not Recommended

Protection and Maintenance

Failing to identify, evaluate, and treat corrosion, or painting over it.

Using harsh cleaning methods, such as grit, sand, or waterblasting in order to strip or clean material.

Introducing new or non-specified brands of paint, colors, or methods of application.

Repair

Failing to immediately apply protective coating to exposed surfaces or otherwise allowing corrosion to form.

Replacement

Replacing original metal features that could be reutilized.

Using a replacement material that does not convey the visual appearance of the surviving, original material.

** Work shall not be initiated without approval of the Directorate of Environmental Compliance and Management (719) 526-4652.

General Specifications

Replacement vents should be constructed of first-quality metal. The vent's overall dimensions and appearance should match that of the original vents. Original grates have two vertical columns of flutes. The flutes are 3/8" thick, and sit 3/4" on center. The grates are backed by inconspicuous metal insect screens.

Vents should be repainted with one coat of primer for metal and at least two finish coats of exterior grade paint; color and finish to match wall surface.

WOOD AND PLASTICS: Character-Defining Features

Exterior

- ◆ Railings on entrance stairs and screened porch openings
- ◆ Stairs (originally at the floor level entrance)
- ◆ Cornice bands and returns on gable ends
- ◆ Vents at gable peaks
- ◆ Dormer vents on roof slopes
- ◆ Lap siding on window spandrels

Interior

- ◆ Dimensioned wood stairs and stair railings
- ◆ Hospital screens in ward rooms
- ◆ Exposed wood flooring
- ◆ Exposed wood ceilings on porches
- ◆ Exposed rough-sawn structural columns and accompanying support brackets
- ◆ Dimensioned wood trimwork around doors, windows, and trap doors
- ◆ Base molding

WOOD AND PLASTICS Management Guidelines

Recommended

Protection and Maintenance

Remove damaged or deteriorated paint only to the next sound layer using the gentlest means possible (handscraper, wire brush, or sand paper), then repainting. Stripping methods including hot air guns, heat plates, and chemical or dip stripping should be employed with great care, and only as a supplement to handscrapping, brushing, and sanding.

Apply specification-approved primer and paint following proper surface preparation and product instructions.

Inspect regularly for wood that is excessively or continually moist and for evidence of insect infestation and fungal rot.

Address evidence of moisture infiltration and infestation as soon as possible.

Use only hot-dipped, zinc-coated nails, bolts, and hardware for use on treated wood.

Countersink and putty all new, exposed nails and screws according to general specifications in Caulk and Sealants.

Repair

Fill moderate-sized holes and check cracks with putty or epoxy filler. Repair should be applied as per general specifications for Caulk and Sealants.

Repair fragile original wood using well-tested consolidants when appropriate. Repairs should be physically, visually, and chemically compatible and identifiable upon close inspection.*

Replacement

Replace deteriorated or damaged wood by carefully patching, piecing-in, or otherwise reinforcing the wood using recognized preservation methods. Replacement work should be permanently dated in an unobtrusive location.*

Not Recommended

Protection and Maintenance

Replacing, rebuilding, or altering any original wood features that could be preserved or consolidated.

Introducing new or non-specified brands of paint, colors, or methods of application.

Failing to identify, evaluate, and treat the causes of wood deterioration, including faulty flashing, leaking gutters, cracks and holes in spandrel siding, deteriorated caulking in joints and seams, plant material growing too close to wood surfaces, or insect or fungus infestation.

Using chemical preservatives (such as creosote) which can change the appearance of wood features.

Using destructive paint removal methods such as propane or butane torches, sandblasting, or waterblasting. These methods can irreversibly damage historic woodwork.

Using thermal devices improperly when removing paint so that historic woodwork is scorched or damaged.

Failing to neutralize wood thoroughly after using chemicals so that new paint does not adhere.

Allowing detachable wood features, like doors, to soak too long in a caustic solution so that the wood grain is raised and the surface roughened.

Repair

Removing or replacing original wood that could be stabilized and conserved, or repaired with limited replacement of deteriorated or missing parts.

Using substitute materials that are physically, visually, or chemically incompatible with the original materials.

Replacement

Removing an original wood feature that is unrepairable and not replacing it, or failing to label the new work.

* Work shall not be initiated without approval of the Colorado Historic Preservation Office (303) 866-3398.

General Specifications

Replacement exterior woodwork should be first-quality, pressure-treated exterior-grade wood. Replacement interior finished millwork should be first-quality interior-grade wood. Finger joints are acceptable only on those elements to be painted.

Woodwork, if chemically stripped, should be thoroughly removed or neutralized before the reapplication of finishes. Exterior woodwork should be primed with at least one coat of exterior-grade primer and finished with at least three coats of paint; color and finish to match wall color. Painted interior woodwork should be repainted with at least one coat of interior-grade primer and finished with at least two coats of interior-grade alkyd-base paint. Varnished interior woodwork should be finished with at least two coats of varnish. Original finishes should be recreated as documentary analysis suggests or as called for in original 800 Series plans and specifications. Interior surfaces should be painted to match a Munsell Color Chart color of 'white' (5Y 8/2). Glidden's formula for this color is

BLK 0 P 7 YOX 0 P 26
 Y-3700 Spred Enamel Latex S-G

Sherwin Williams' formula for this color is

BAC	COLORANT	OZ	32	64	128
B1	Black	--	13	--	---
Y3	Deep Gold	--	46	1	1
R2	Maroon	--	--	1	1

with one gallon of Pure White Base X

Classic 99 Latex Flat Wall and Trim Paint.

**THERMAL AND MOISTURE PROTECTION:
Character-Defining Features**

Roofing

- ◆ Moderate-pitch gable roofs
- ◆ Wood eyebrow dormer vents
- ◆ Slightly overhung, boxed eaves
- ◆ Gutterless eaves
- ◆ Cornice band at eaveline, with returns on gable sides
- ◆ Tabbed, mineral-surfaced asphalt shingles

THERMAL AND MOISTURE PROTECTION Management Guidelines

Recommended

ROOFING

Protection and Maintenance

Maintain proper attic ventilation by keeping vents clean and clear.

Provide adequate anchorage for roofing material to guard against wind damage and moisture penetration.

Repair

Repair extensively deteriorated sheathing, rafter, or truss material, and dormer vents with the limited use of replacement material. All work should be permanently dated in an inconspicuous location.*

Wet sheathing, caused by a failure within the roofing system, may be reutilized after drying.

Replacement

Replace roofing material with specification-approved shingles. Replacement may include the use of additional waterproofing beneath the shingles. The appearance and construction of replacement roof material should match that of the original. Replacement material should be permanently dated in an inconspicuous location.*

THERMAL INSULATION

Install thermal insulation in attics and crawlspaces. Install insulating material on the inside of masonry walls where interior doors and window sills and surrounds are preserved.

Not Recommended

ROOFING

Protection and Maintenance

Failing to maintain proper ventilation.

Using roof fasteners susceptible to corrosion.

Failing to immediately trace and address leaks at their source.

Repair

Replacing dormer vents or other features when the repair of materials or limited replacement of deteriorated or missing parts is appropriate.

Removing unrepairable dormer vents or other features and not replacing them, or failing to label the new work.

THERMAL INSULATION

Applying thermal insulation with a high moisture content in wall cavities.

Installing wall insulation without considering its visual and physical effect on character defining features.

* Work shall not be initiated without approval of the Colorado Historic Preservation Office (303) 866-3398.

Recommended

CAULK AND SEALANTS

Install caulk at all exterior window and door jambs. Bead should be flush with surface, unless required for drainage.**

Install sealant around any original remaining window sashes.**

Install sealant around any original or new roof protrusions.**

Not Recommended

CAULK AND SEALANTS

Applying caulk or sealant that is visually, physically, or chemically incompatible with the surrounding building materials.

Installing caulk or sealant without considering its visual and physical effect on character defining features.

General Specifications

ROOFING

Replacement roofing should consist of tabbed mineral-surfaced asphalt shingles. Waterproofing should be a reversible application compatible with the existing sub-sheathing and the new shingle roofing.

Replacement sheathing and structural members should consist of first-quality, pressure-treated exterior-grade wood.

THERMAL INSULATION

Insulation should be able to be removed without damage or significant alteration of the original structure.

Insulation should be vapor-permeable.

CAULK AND SEALANTS

The applications of caulk and sealant should be reversible. Caulk and liquid sealants at window and door jambs and other openings should be flexible when cured, inconspicuous, and color-matched to surrounding surfaces, or primed and painted, according to manufacturer's instructions, to match surrounding surfaces.

DOORS AND WINDOWS: Character-Defining Features

Doors

Original Entrance-and-Exit

- ◆ Basic configuration of five horizontal panels (varies with glazing)
- ◆ Panels are flat, not raised
- ◆ Exterior screen doors?
- ◆ Simple metal hardware
 - Two or three hinges per door
 - Hinges are five-knuckle butt type, mortised into door, not into frame
 - Ball-tip hinge pins
 - Three-hole leaves, unornamented
 - Mortised locksets with keyed deadbolts
 - Plain-set rectangular plates, with beveled edges
 - Hollow, round metal doorknobs above a simple keyhole
 - Mortised metal strike plates

*Access**

- ◆ Paneled wood access door
- ◆ Panel flush, not raised
- ◆ Hinged on the side
- ◆ Equipped with lock

* Listed character-defining features of access doors are *probable* only.

Windows

Original

- ◆ Regular and symmetrical appearance
- ◆ Windows placed in simple, punched openings
- ◆ Wood frame
- ◆ Double-hung
- ◆ Multi-lights (panes) in each sash
 - Obscured glass in lower sashes of type *C* windows
 - Clear glass in all other sashes
- ◆ Simple wood surrounds and flat wood sills inside
- ◆ Shutterless exteriors
- ◆ Curtains or shades?
- ◆ Hardware
 - Metal thumb-latches
 - Spring-pinned lower sashes
- ◆ Hinged wire window screens (at operable windows)
 - Wood rails and stiles
 - Wire-guard insect screens
 - Two metal hangers per screen

DOORS AND WINDOWS Management Guidelines

Recommended

DOORS

Protection and Maintenance

Regular cleaning and removal of loose paint prior to reapplication with specification-approved finish.

Install and maintain caulk and weatherstrip on exterior units to maximize energy efficiency.

Periodic lubrication of operable hinges and hardware to extend life and inhibit corrosion.

Repair

Repair missing hardware or doors with salvage or in-kind material.

Replacement

Restore, repair and reuse original remaining material, including wood frames, surrounds, and sills, as much as is practicable.

Replace non-original doors and hardware with salvage or in-kind, specification-approved units painted to match original. Replacement units should be permanently dated in an inconspicuous location.**

Not Recommended

DOORS

Protection and Maintenance

Applying excessive layers of paint to hardware.

Introducing new or non-specified brands of paint, colors, or methods of application.

Replacement

Using a substitute unit that is physically incompatible with the character of the historic, original doors.

** Work shall not be initiated without approval of the Directorate of Environmental Compliance and Management (719) 526-4652.

Recommended

WINDOWS

Protection and Maintenance of Restoration Units

Regular cleaning and removal of loose paint prior to reapplication with specification-approved finish.

Install and maintain caulk and weatherstrip to maximize energy efficiency.

Exterior storm windows, if installed, must not damage or obscure original or restoration windows and frames. Interior storm windows, if installed, should include air-tight gaskets, ventilating holes, and/or removable clips to ensure proper maintenance and to avoid condensation on original or restoration windows.**

Replacement

Replace non-original windows with salvage or in-kind, specification-approved units that match originals in size, operation, glazing pattern, and muntin profile. Replacement units should be permanently dated in an inconspicuous location.**

Restore, repair, and reuse original remaining material, including wood frames, surrounds, sills, and screens, as much as is practicable.

Remove, document and archive one example of the existing modern vinyl-clad windows to facilitate future research.**

Not Recommended

WINDOWS

Replacement

Using a substitute unit that is physically incompatible with the character of the historic, original windows.

Using exterior shading devices.

Using false-muntined windows.

Introducing new or non-specified brands of paint, colors, or methods of application.

Installing interior storm windows if they allow moisture to accumulate and damage the window.

Installing exterior storm windows that obscure the original or restored windows and frames.

Installing replacement window and transom units with fixed thermal glazing or permitting windows and transoms to remain inoperable rather than utilizing them for their energy conserving potential.

General Specifications

DOORS

Replacement exterior doors should be constructed of exterior grade wood. Replacement doors should match as closely as possible the size, material, construction, and rail, stile, and panel profiles of the original doors. Fire-rated interior and exterior doors should be visually similar to the original wood doors.

WINDOWS

Replacement windows should match as closely as possible the original window's function, size, material, number of lights, and muntin profile.

INTERIOR SPACES, FINISHES, AND FEATURES:
Character-Defining Features

- ◆ Central, double-loaded hallways
- ◆ Scissor stairs, constructed of wood, with dimension wood rails
- ◆ Simple door and window surrounds
- ◆ Wood base molding
- ◆ Finished wood, rolled linoleum or tile flooring
- ◆ Predominantly light paint colors, with glossy or eggshell finishes
- ◆ Occasional stained and varnished exposed woodwork

INTERIOR SPACES, FINISHES, AND FEATURES Management Guidelines

Recommended

Protection and Maintenance

Protect significant intact interior spaces, including room and building size, building configuration, room proportion, relationship between rooms and corridors, and the relationship of features to spaces by not altering the original, basic plan configuration.

Protect and maintain original interior features, such as molding, surrounds, and railings by applying unobtrusive, reversible, wear-reducing applications such as stair tread covers and corner bumpers.*

Protect and maintain original interior finishes through appropriate surface treatments such as regular cleaning, limited removal of paint, and reapplication of specification-approved protective coating systems.

Protect interior features against damage during project work by covering with heavy canvas or plastic sheets.

Install protective coverings in areas of heavy pedestrian traffic to protect historic features like original flooring.

Remove damaged or deteriorated paints and finishes to the next sound layer using the gentlest method possible. Repaint or refinish using specification-approved products.

Repair

Repair remaining original finishes and features by reinforcing historic materials. Repair should include limited replacement with salvage, in-kind, or compatible substitute materials. Replacement work should be permanently dated in an inconspicuous location.

Replacement

Replace damaged or missing elements with salvage, in-kind, or compatible replacement material that conveys the same form, design, and overall visual appearance as the historic feature. Replacement materials should, at a minimum, be equal to the original feature's performance capacity. Replacement material should be permanently dated in an inconspicuous location.**

Not Recommended

Protection and Maintenance

Altering a floor plan, significant space, original feature, or finish by introducing new designs and spaces or non-specified materials or finishes.

Failing to provide adequate protection to materials on a cyclical basis so that deterioration of interior features results.

Failing to provide proper protection of interior features and finishes during repair work.

Failing to take new use patterns, such as heavy visitor traffic, into consideration so that interior features, finishes, and mechanical systems are damaged.

Changing the texture of original features through sandblasting or use of abrasive methods to remove paint, discoloration, or plaster. This includes exposed wood (including structural members), plaster, and gypsum board surfaces.

Repair

Using substitute materials for replacement parts that do not convey the visual appearance of the original parts or that are physically or chemically incompatible.

Removing an original feature or finish that is unrepairable and not replacing it, or failing to label the new work.

Recommended

** Work shall not be initiated without approval of the Directorate of Environmental Compliance and Management (719) 526-4652.

Replacement (continued)

Remove and archive samples of non-historic materials that are removed, such as paneling, ceiling tile, and flooring to facilitate future research.

Not Recommended

General Specifications

Interior walls, floors, and ceilings should be prepared and primed, painted, or varnished according to original 800 Series plans and specifications. Painted surfaces should have a minimum of one coat of primer and two coats of paint. Painted interior woodwork should be primed with at least one coat of primer and finished with at least two coats of paint. Interior walls, doors, trim, molding, and electrical plates should be painted to match a Munsell Color Chart color of 'white' (5Y 8/2). Glidden's formula for this color is

BLK 0 P 7 YOX 0 P 26
 Y-3700 Spred Enamel Latex S-G.

Sherwin Williams' formula for this color is

BAC	COLORANT	OZ	32	64	128
B1	Black	--	13	--	---
Y3	Deep Gold	--	46	1	1
R2	Maroon	--	--	1	1

with one gallon of Pure White Base X

Classic 99 Latex Flat Wall and Trim Paint

Stained interior woodwork should have at least two coats of satin-finish varnish.

Surfaces, if chemically stripped, should be neutralized before the reapplication of finishes. Wood surfaces shall be finished according to general specifications in Wood and Plastics.

STRUCTURAL SYSTEMS: Character-Defining Features

- ◆ Exposed, rough-sawn structural wood columns and beams
- ◆ Wood-frame walls
- ◆ Wood floor and ceiling joists
- ◆ Wood rafters
- ◆ Diagonally-laid sub-flooring and wall sheathing

STRUCTURAL SYSTEMS Management Guidelines

Recommended

Protection and Maintenance

Protect structural systems by maintaining a watertight building envelope and controlling insect infestation of wood structural members.

Conduct Maintenance Surveys using non-invasive or non-destructive techniques whenever possible.

Avoid cutting structural members for the installation of mechanical, plumbing, or electrical systems.

Repair

Repair weakened structural members in a manner consistent with the original construction. Damaged or deteriorated structural load-bearing members should be investigated by a licensed structural engineer familiar with the Secretary of the Interior's Standards for Historic Preservation for determination of necessary repair. Replacement work should be permanently dated in an inconspicuous location.

Replacement

Replace failed, heavily damaged, or missing members with salvage, in-kind, or compatible material that conveys the same form, design, and overall visual appearance as the historic feature. Replacement material should, at a minimum, be equal to the original feature's performance capacity. Damaged or deteriorated structural load-bearing members should be investigated by a licensed structural engineer familiar with the Secretary of the Interior's Standards for Historic Preservation for recommendation of necessary repair. Replacement material should be permanently dated in an inconspicuous location.**

Not Recommended

Protection and Maintenance

Leaving known structural problems, such as water infiltration, deflection of floors, cracking and bowing of walls, or racking of structural members untreated.

Utilizing destructive probing techniques that will damage or destroy structural material.

Compromising the integrity of structural members by cutting or drilling through them.

Repair

Altering visible features of original structural systems.

Upgrading structurally in a manner that diminishes the historic character of the exterior or that damages or significantly alters interior features or spaces.

Replacement

Replacing a structural member or other feature of the structure when it could be augmented and retained.

Installing a visible replacement feature that does not convey the same visual appearance, e.g., replacing exposed wood columns with steel columns.

Using substitute material that does not equal the load-bearing capabilities of the original material and design or is otherwise physically or chemically incompatible.

**Work shall not be initiated without approval of the Directorate of Environmental Compliance and Management (719) 526-4652.

General Specifications

Replacement structural members should be of pressure-treated, construction-grade lumber or timber to match existing. Exposed structural members should be painted as per specifications in Wood and Plastics.

SPECIAL CONSTRUCTION: Character-Defining Features

Original Sun Porches

- ◆ Two-story construction
- ◆ Flat roofs
- ◆ Full-height screened openings
- ◆ Simple wood railings

Original Stoops

- ◆ Wood steps and structural members
- ◆ Simple dimension wood railings
- ◆ Stoop supported by a single concrete step or foundation member

SPECIAL CONSTRUCTION Management Guidelines

Recommended

**ORIGINAL SUN PORCHES
ORIGINAL STOOPS**

Protect, maintain, repair and replace all elements according to the management guidelines for each material.

Not Recommended

**ORIGINAL SUN PORCHES
ORIGINAL STOOPS**

Failing to observe the management guidelines and general specifications for each material present in Special Construction.

General Specifications

Replacement materials should follow the original 800 Series plans and specifications. Materials should be finished according to general specifications for their type.

MECHANICAL AND ELECTRICAL: Character-Defining Features

Mechanical

- ◆ Overhead fire sprinkler system with exposed pipes and heads
- ◆ Steam heat system with exposed pipes and radiators

Electrical

Exterior and Interior

- ◆ Incandescent lighting
 - Exposed conduit
 - Porcelain fixtures
 - Simple stamped-metal shades

Interior

- ◆ Rectangular, beveled-metal switch and outlet plates
- ◆ Patient call lights above patient rooms
- ◆ Patient call buttons in patient rooms

MECHANICAL AND ELECTRICAL Management Guidelines

Recommended

Protection and Maintenance

Improve the energy efficiency of existing mechanical systems to reduce the need for new equipment.

Improve the energy efficiency of the building, e.g., with curtains and insulation, to reduce the load on existing mechanical systems.

Maintain proper circuit/system loading to prevent overload or failure.

Repair

Repair original mechanical and electrical systems by augmenting or upgrading system parts such as new pipes and outlets.*

Replacement

Replace with salvage, in-kind, or compatible substitute material those visible features of the original mechanical and electrical systems that are extensively deteriorated.**

Install new mechanical systems, such as air conditioning, in a way that results in the least alteration possible to the building.**

Provide adequate structural support for new mechanical equipment, especially that in attic spaces.**

Install the vertical runs of new ducts, pipes, or cables in closets, service rooms, pipe chases, and wall cavities.**

Archive samples or plans for non-historic mechanical and electrical systems, such as air conditioning and fluorescent lighting fixtures, to facilitate future research.**

Not Recommended

Protection and Maintenance

Altering visible decorative features of the original mechanical or electrical systems.

Failing to provide adequate protection of materials on a cyclical basis so that deterioration of mechanical or electrical systems and their visible features results.

Enclosing mechanical systems in areas that are not adequately ventilated.

Installing unnecessary air conditioning or climate control systems that can add excessive moisture to the building.

Installing unnecessary additional lighting, outlets, and switches.

Overloading existing electrical circuits, and heating and plumbing systems.

Repair

Replacing all or some of an original mechanical or electrical system when it could be upgraded and retained.

Replacement

Installing a new mechanical or electrical system so that significant original structural or interior features are altered.

Failing to consider the weight and design of new mechanical equipment so that structural members or finished surfaces are weakened or cracked.

Concealing new mechanical or electrical systems in walls or ceilings in a manner that requires the removal of original building material.

Cutting through relatively inflexible features such as masonry walls in order to install air conditioning units or electrical outlets or switches.

* Work shall not be initiated without approval of the Colorado Historic Preservation Office (303) 866-3398.

** Work shall not be initiated without approval of the Directorate of Environmental Compliance and Management (719) 526-4652.

Recommended

Not Recommended

Replacement (continued)

Failing to remove non-original mechanical and electrical system elements such as air conditioning duct work and fluorescent fixtures.

General Specifications

Replacement elements should consist of first quality materials.

SITE AND DISTRICT: Character-Defining Features

- ◆ Low-slung buildings
- ◆ Corridors both perpendicular and parallel to buildings
- ◆ Uniform appearance and symmetrical arrangement of buildings
- ◆ Rectilinear organization of buildings, corridors, and sidewalks
- ◆ Pattern of solid and void created by courtyards between buildings
- ◆ Relatively undeveloped landscape setting
- ◆ Flat topography

SITE AND DISTRICT Management Guidelines

Recommended

Protection and Maintenance

Protect and maintain the existing topography and the relationship between remaining buildings and courtyards.

Maintain proper site drainage.

Survey and document areas where terrain will be altered during work to determine the potential impact to landscape features or archeological resources.**

Protect, i.e., preserve in place, important archeological resources. Plan and carry out any necessary investigation prior to disturbance when preservation in place is not feasible.**

Manage vegetation to prevent impact on buildings or structures by branches or roots.

Repair

Repair or reinforce original material such as sidewalks, if possible.

Replacement

Replace features, such as sidewalks that are too damaged to repair, with in-kind material.*

Design and install replacement features to assist in energy conservation of nearby buildings.*

Not Recommended

Protection and Maintenance

Retaining known non-historic buildings or landscape features.

Failing to undertake adequate measures to assure the protection of building and landscape features.

Repair

Replacing an original feature of the landscape setting when repair and limited replacement of deteriorated or missing parts is appropriate.

Using a substitute material for the replacement part that does not convey the visual appearance of the surviving parts of the feature or landscape, or that is physically, chemically, or ecologically incompatible.

Replacement

Removing an original feature of the building or landscape that is unrepairable and not replacing it, or failing to document the new work.

Removing a historically compatible landscape feature that assists in energy conservation in nearby buildings.

* Work shall not be initiated without approval of the Colorado Historic Preservation Office (303) 866-3398.

** Work shall not be initiated without approval of the Directorate of Environmental Compliance and Management (719) 526-4652.

General Specifications

Replacement concrete should be mixed according to general specifications as per Concrete.

ACCESSIBILITY CONSIDERATIONS

Management Guidelines

Recommended

Comply with barrier-free access requirements in such a manner that spaces, features, and finishes from the restored period are preserved.

Work with access specialists and Colorado Historic Preservation Office in the design of appropriate access solutions.

Provide barrier-free access that promotes independence to the highest degree practicable, while preserving significant historic features.

Find solutions to meet accessibility requirements, such as those that apply to compatible ramps, paths and lifts, that minimize the impact on historic buildings and site.

Not Recommended

Altering, damaging, or destroying features from the restored period while attempting to comply with accessibility requirements.

Making access modifications that do not provide a reasonable balance between independent, safe access and preservation of historic features.

Making modifications for accessibility without considering the impact on the historic building and its site.

Historic Building Maintenance Checklist

Old Hospital Complex, Fort Carson

Building No. S6237 Date _____

Condition for each building element on this checklist is expressed in terms of function and operation, as well as expected life with no maintenance and normal use.

- Excellent Performing all functions and operations; will continue to perform until next inspection cycle.
- Good Minor limits of function and operation; will perform within limits for at least 1/2 of inspection cycle.
- Fair Major limits of function and operation; limited life due to a condition that will continue to worsen.
- Poor Not performing important functions and operations; at or near end of useful life.

Only items checked off in the left column were evaluated.

Key to Headings
 Major System or Section
 Location or Subsection (Inspection cycle)
 Element (description of element, inspection cycle, and condition)
 Sub-element

Reference to
 further
 details in
 Inspection
 Notes No.

Weather Envelope

	E	G	F	P	
Roof exterior (Annually)					
<input type="radio"/> shingles	<input type="checkbox"/>	<input type="checkbox"/>	<input type="checkbox"/>	<input type="checkbox"/>	_____
<input type="radio"/> flashing	<input type="checkbox"/>	<input type="checkbox"/>	<input type="checkbox"/>	<input type="checkbox"/>	_____
<input type="radio"/> drip edge	<input type="checkbox"/>	<input type="checkbox"/>	<input type="checkbox"/>	<input type="checkbox"/>	_____
<input type="radio"/> dormers	<input type="checkbox"/>	<input type="checkbox"/>	<input type="checkbox"/>	<input type="checkbox"/>	_____
Walls (Every 5 years)					
<input type="radio"/> cornice	<input type="checkbox"/>	<input type="checkbox"/>	<input type="checkbox"/>	<input type="checkbox"/>	_____
<input type="radio"/> paint	<input type="checkbox"/>	<input type="checkbox"/>	<input type="checkbox"/>	<input type="checkbox"/>	_____
<input type="radio"/> cinder blocks (broken, chipped)	<input type="checkbox"/>	<input type="checkbox"/>	<input type="checkbox"/>	<input type="checkbox"/>	_____
<input type="radio"/> paint	<input type="checkbox"/>	<input type="checkbox"/>	<input type="checkbox"/>	<input type="checkbox"/>	_____
<input type="radio"/> mortar joint	<input type="checkbox"/>	<input type="checkbox"/>	<input type="checkbox"/>	<input type="checkbox"/>	_____
<input type="radio"/> gable vents	<input type="checkbox"/>	<input type="checkbox"/>	<input type="checkbox"/>	<input type="checkbox"/>	_____
Porches (Semi-annually)					
<input type="radio"/> foundation	<input type="checkbox"/>	<input type="checkbox"/>	<input type="checkbox"/>	<input type="checkbox"/>	_____
<input type="radio"/> walls	<input type="checkbox"/>	<input type="checkbox"/>	<input type="checkbox"/>	<input type="checkbox"/>	_____
<input type="radio"/> railings	<input type="checkbox"/>	<input type="checkbox"/>	<input type="checkbox"/>	<input type="checkbox"/>	_____
<input type="radio"/> screens	<input type="checkbox"/>	<input type="checkbox"/>	<input type="checkbox"/>	<input type="checkbox"/>	_____
<input type="radio"/> windows	<input type="checkbox"/>	<input type="checkbox"/>	<input type="checkbox"/>	<input type="checkbox"/>	_____
Drainage (Every 5 years)					
<input type="radio"/> diversion channels	<input type="checkbox"/>	<input type="checkbox"/>	<input type="checkbox"/>	<input type="checkbox"/>	_____
<input type="radio"/> flow away from foundation	<input type="checkbox"/>	<input type="checkbox"/>	<input type="checkbox"/>	<input type="checkbox"/>	_____
<input type="radio"/> drains and lines	<input type="checkbox"/>	<input type="checkbox"/>	<input type="checkbox"/>	<input type="checkbox"/>	_____

Doors (Every 5 years)		E	G	F	P	
<input type="radio"/>	paint	<input type="checkbox"/>	<input type="checkbox"/>	<input type="checkbox"/>	<input type="checkbox"/>	_____
<input type="radio"/>	caulking	<input type="checkbox"/>	<input type="checkbox"/>	<input type="checkbox"/>	<input type="checkbox"/>	_____
<input type="radio"/>	glazing	<input type="checkbox"/>	<input type="checkbox"/>	<input type="checkbox"/>	<input type="checkbox"/>	_____
<input type="radio"/>	glazing putty	<input type="checkbox"/>	<input type="checkbox"/>	<input type="checkbox"/>	<input type="checkbox"/>	_____
<input type="radio"/>	surrounds	<input type="checkbox"/>	<input type="checkbox"/>	<input type="checkbox"/>	<input type="checkbox"/>	_____
<input type="radio"/>	sill	<input type="checkbox"/>	<input type="checkbox"/>	<input type="checkbox"/>	<input type="checkbox"/>	_____
<input type="radio"/>	light fixture above door	<input type="checkbox"/>	<input type="checkbox"/>	<input type="checkbox"/>	<input type="checkbox"/>	_____
<input type="radio"/>	hardware	<input type="checkbox"/>	<input type="checkbox"/>	<input type="checkbox"/>	<input type="checkbox"/>	_____

Windows (Annually)		E	G	F	P	
<input type="radio"/>	paint	<input type="checkbox"/>	<input type="checkbox"/>	<input type="checkbox"/>	<input type="checkbox"/>	_____
<input type="radio"/>	caulking	<input type="checkbox"/>	<input type="checkbox"/>	<input type="checkbox"/>	<input type="checkbox"/>	_____
<input type="radio"/>	glazing	<input type="checkbox"/>	<input type="checkbox"/>	<input type="checkbox"/>	<input type="checkbox"/>	_____
<input type="radio"/>	glazing putty	<input type="checkbox"/>	<input type="checkbox"/>	<input type="checkbox"/>	<input type="checkbox"/>	_____
<input type="radio"/>	surrounds	<input type="checkbox"/>	<input type="checkbox"/>	<input type="checkbox"/>	<input type="checkbox"/>	_____
<input type="radio"/>	sill	<input type="checkbox"/>	<input type="checkbox"/>	<input type="checkbox"/>	<input type="checkbox"/>	_____
<input type="radio"/>	screens	<input type="checkbox"/>	<input type="checkbox"/>	<input type="checkbox"/>	<input type="checkbox"/>	_____
<input type="radio"/>	hardware	<input type="checkbox"/>	<input type="checkbox"/>	<input type="checkbox"/>	<input type="checkbox"/>	_____

Structural System

Roof and Wall Exterior (Annually)		E	G	F	P	
<input type="radio"/>	alignment	<input type="checkbox"/>	<input type="checkbox"/>	<input type="checkbox"/>	<input type="checkbox"/>	_____

Foundation Exterior (Annually)		E	G	F	P	
<input type="radio"/>	drainage	<input type="checkbox"/>	<input type="checkbox"/>	<input type="checkbox"/>	<input type="checkbox"/>	_____
<input type="radio"/>	cracking/settling	<input type="checkbox"/>	<input type="checkbox"/>	<input type="checkbox"/>	<input type="checkbox"/>	_____
<input type="radio"/>	foundation vents	<input type="checkbox"/>	<input type="checkbox"/>	<input type="checkbox"/>	<input type="checkbox"/>	_____
<input type="radio"/>	crawl space hatches	<input type="checkbox"/>	<input type="checkbox"/>	<input type="checkbox"/>	<input type="checkbox"/>	_____
<input type="radio"/>	hatch doors	<input type="checkbox"/>	<input type="checkbox"/>	<input type="checkbox"/>	<input type="checkbox"/>	_____
<input type="radio"/>	surrounds	<input type="checkbox"/>	<input type="checkbox"/>	<input type="checkbox"/>	<input type="checkbox"/>	_____

Foundation Interior (Every 5 years)		E	G	F	P	
<input type="radio"/>	evidence of water entry	<input type="checkbox"/>	<input type="checkbox"/>	<input type="checkbox"/>	<input type="checkbox"/>	_____
<input type="radio"/>	evidence of animal entry or infestation	<input type="checkbox"/>	<input type="checkbox"/>	<input type="checkbox"/>	<input type="checkbox"/>	_____

Attic Framing (Every 5 years)		E	G	F	P	
<input type="radio"/>	sheathing	<input type="checkbox"/>	<input type="checkbox"/>	<input type="checkbox"/>	<input type="checkbox"/>	_____
<input type="radio"/>	rafters/trusses	<input type="checkbox"/>	<input type="checkbox"/>	<input type="checkbox"/>	<input type="checkbox"/>	_____
<input type="radio"/>	dormer framing	<input type="checkbox"/>	<input type="checkbox"/>	<input type="checkbox"/>	<input type="checkbox"/>	_____

Attic Floor (Every 5 years)		E	G	F	P	
<input type="radio"/>	plates	<input type="checkbox"/>	<input type="checkbox"/>	<input type="checkbox"/>	<input type="checkbox"/>	_____
<input type="radio"/>	joists	<input type="checkbox"/>	<input type="checkbox"/>	<input type="checkbox"/>	<input type="checkbox"/>	_____
<input type="radio"/>	flooring	<input type="checkbox"/>	<input type="checkbox"/>	<input type="checkbox"/>	<input type="checkbox"/>	_____
<input type="radio"/>	insulation	<input type="checkbox"/>	<input type="checkbox"/>	<input type="checkbox"/>	<input type="checkbox"/>	_____

Exterior Detail

Entrance Stairs (Annually)

	E	G	F	P	
<input type="radio"/> treads	<input type="checkbox"/>	<input type="checkbox"/>	<input type="checkbox"/>	<input type="checkbox"/>	_____
<input type="radio"/> risers	<input type="checkbox"/>	<input type="checkbox"/>	<input type="checkbox"/>	<input type="checkbox"/>	_____
<input type="radio"/> carriage	<input type="checkbox"/>	<input type="checkbox"/>	<input type="checkbox"/>	<input type="checkbox"/>	_____
<input type="radio"/> supports	<input type="checkbox"/>	<input type="checkbox"/>	<input type="checkbox"/>	<input type="checkbox"/>	_____
<input type="radio"/> paint	<input type="checkbox"/>	<input type="checkbox"/>	<input type="checkbox"/>	<input type="checkbox"/>	_____
<input type="radio"/> concrete pier	<input type="checkbox"/>	<input type="checkbox"/>	<input type="checkbox"/>	<input type="checkbox"/>	_____

Grounds and Site

<input type="radio"/> Lawns (Semi-annually)	<input type="checkbox"/>	<input type="checkbox"/>	<input type="checkbox"/>	<input type="checkbox"/>	_____
<input type="radio"/> Plantings (Semi-annually) Endangering Building?	<input type="checkbox"/>	Yes	<input type="checkbox"/>	No	_____
<input type="radio"/> Sidewalks (Semi-annually)	<input type="checkbox"/>	<input type="checkbox"/>	<input type="checkbox"/>	<input type="checkbox"/>	_____

Interior

Walls (Every 5 years)

<input type="radio"/> structural integrity of wall bond/plaster (cracks)	<input type="checkbox"/>	<input type="checkbox"/>	<input type="checkbox"/>	<input type="checkbox"/>	_____
<input type="radio"/> wainscot	<input type="checkbox"/>	<input type="checkbox"/>	<input type="checkbox"/>	<input type="checkbox"/>	_____
<input type="radio"/> base molding	<input type="checkbox"/>	<input type="checkbox"/>	<input type="checkbox"/>	<input type="checkbox"/>	_____
<input type="radio"/> paint	<input type="checkbox"/>	<input type="checkbox"/>	<input type="checkbox"/>	<input type="checkbox"/>	_____
<input type="radio"/> cleanliness	<input type="checkbox"/>	<input type="checkbox"/>	<input type="checkbox"/>	<input type="checkbox"/>	_____

Floors (Semi-annually)

<input type="radio"/> structural integrity of flooring material	<input type="checkbox"/>	<input type="checkbox"/>	<input type="checkbox"/>	<input type="checkbox"/>	_____
<input type="radio"/> paint/finish	<input type="checkbox"/>	<input type="checkbox"/>	<input type="checkbox"/>	<input type="checkbox"/>	_____
<input type="radio"/> cleanliness	<input type="checkbox"/>	<input type="checkbox"/>	<input type="checkbox"/>	<input type="checkbox"/>	_____

Ceilings (Every 5 years)

<input type="radio"/> structural integrity of wallboard/ plaster (cracks, sagging)	<input type="checkbox"/>	<input type="checkbox"/>	<input type="checkbox"/>	<input type="checkbox"/>	_____
<input type="radio"/> paint	<input type="checkbox"/>	<input type="checkbox"/>	<input type="checkbox"/>	<input type="checkbox"/>	_____
<input type="radio"/> cleanliness (dirt, water stains)	<input type="checkbox"/>	<input type="checkbox"/>	<input type="checkbox"/>	<input type="checkbox"/>	_____

Exposed Structural Members (Every 5 years)

<input type="radio"/> integrity (splitting, warping)	<input type="checkbox"/>	<input type="checkbox"/>	<input type="checkbox"/>	<input type="checkbox"/>	_____
<input type="radio"/> paint	<input type="checkbox"/>	<input type="checkbox"/>	<input type="checkbox"/>	<input type="checkbox"/>	_____
<input type="radio"/> hardware	<input type="checkbox"/>	<input type="checkbox"/>	<input type="checkbox"/>	<input type="checkbox"/>	_____

Stairs (Annually)

<input type="radio"/> railings	<input type="checkbox"/>	<input type="checkbox"/>	<input type="checkbox"/>	<input type="checkbox"/>	_____
<input type="radio"/> treads	<input type="checkbox"/>	<input type="checkbox"/>	<input type="checkbox"/>	<input type="checkbox"/>	_____
<input type="radio"/> structural	<input type="checkbox"/>	<input type="checkbox"/>	<input type="checkbox"/>	<input type="checkbox"/>	_____

Mechanical (Annually)

<input type="radio"/> emergency lighting and exit signs	<input type="checkbox"/>	<input type="checkbox"/>	<input type="checkbox"/>	<input type="checkbox"/>	_____
<input type="radio"/> fire sprinkler system (leakage, corrosion, obscured heads)	<input type="checkbox"/>	<input type="checkbox"/>	<input type="checkbox"/>	<input type="checkbox"/>	_____
<input type="radio"/> steam radiators and piping (leakage, corrosion, frozen valves)	<input type="checkbox"/>	<input type="checkbox"/>	<input type="checkbox"/>	<input type="checkbox"/>	_____

	E	G	F	P	
<input type="radio"/> electrical					
<input type="radio"/> switches (operational, intact)	<input type="checkbox"/>	<input type="checkbox"/>	<input type="checkbox"/>	<input type="checkbox"/>	_____
<input type="radio"/> fixtures (operational, intact?)	<input type="checkbox"/>	<input type="checkbox"/>	<input type="checkbox"/>	<input type="checkbox"/>	_____
<input type="radio"/> outlets (operational, intact overloaded?)	<input type="checkbox"/>	<input type="checkbox"/>	<input type="checkbox"/>	<input type="checkbox"/>	_____
<input type="radio"/> patient call system (operational if applicable)	<input type="checkbox"/>	<input type="checkbox"/>	<input type="checkbox"/>	<input type="checkbox"/>	_____
<input type="radio"/> plumbing					
<input type="radio"/> sinks	<input type="checkbox"/>	<input type="checkbox"/>	<input type="checkbox"/>	<input type="checkbox"/>	_____
<input type="radio"/> toilets	<input type="checkbox"/>	<input type="checkbox"/>	<input type="checkbox"/>	<input type="checkbox"/>	_____
<input type="radio"/> tubs, showers	<input type="checkbox"/>	<input type="checkbox"/>	<input type="checkbox"/>	<input type="checkbox"/>	_____
<input type="radio"/> fixtures	<input type="checkbox"/>	<input type="checkbox"/>	<input type="checkbox"/>	<input type="checkbox"/>	_____
<input type="radio"/> piping	<input type="checkbox"/>	<input type="checkbox"/>	<input type="checkbox"/>	<input type="checkbox"/>	_____
<input type="radio"/> Doors (Semi-annually)					
<input type="radio"/> paint	<input type="checkbox"/>	<input type="checkbox"/>	<input type="checkbox"/>	<input type="checkbox"/>	_____
<input type="radio"/> glazing	<input type="checkbox"/>	<input type="checkbox"/>	<input type="checkbox"/>	<input type="checkbox"/>	_____
<input type="radio"/> glazing putty	<input type="checkbox"/>	<input type="checkbox"/>	<input type="checkbox"/>	<input type="checkbox"/>	_____
<input type="radio"/> surrounds	<input type="checkbox"/>	<input type="checkbox"/>	<input type="checkbox"/>	<input type="checkbox"/>	_____
<input type="radio"/> hardware	<input type="checkbox"/>	<input type="checkbox"/>	<input type="checkbox"/>	<input type="checkbox"/>	_____
<input type="radio"/> Windows (Semi-annually)					
<input type="radio"/> paint	<input type="checkbox"/>	<input type="checkbox"/>	<input type="checkbox"/>	<input type="checkbox"/>	_____
<input type="radio"/> glazing	<input type="checkbox"/>	<input type="checkbox"/>	<input type="checkbox"/>	<input type="checkbox"/>	_____
<input type="radio"/> glazing putty	<input type="checkbox"/>	<input type="checkbox"/>	<input type="checkbox"/>	<input type="checkbox"/>	_____
<input type="radio"/> surrounds	<input type="checkbox"/>	<input type="checkbox"/>	<input type="checkbox"/>	<input type="checkbox"/>	_____
<input type="radio"/> hardware	<input type="checkbox"/>	<input type="checkbox"/>	<input type="checkbox"/>	<input type="checkbox"/>	_____
<input type="radio"/> curtains	<input type="checkbox"/>	<input type="checkbox"/>	<input type="checkbox"/>	<input type="checkbox"/>	_____
<input type="radio"/> Built-in cabinetry (Every 5 years)	<input type="checkbox"/>	<input type="checkbox"/>	<input type="checkbox"/>	<input type="checkbox"/>	_____
<input type="radio"/> Furniture (Every 5 years)	<input type="checkbox"/>	<input type="checkbox"/>	<input type="checkbox"/>	<input type="checkbox"/>	_____
<input type="radio"/> Other	<input type="checkbox"/>	<input type="checkbox"/>	<input type="checkbox"/>	<input type="checkbox"/>	_____
<input type="radio"/>	<input type="checkbox"/>	<input type="checkbox"/>	<input type="checkbox"/>	<input type="checkbox"/>	_____
<input type="radio"/>	<input type="checkbox"/>	<input type="checkbox"/>	<input type="checkbox"/>	<input type="checkbox"/>	_____
<input type="radio"/>	<input type="checkbox"/>	<input type="checkbox"/>	<input type="checkbox"/>	<input type="checkbox"/>	_____

Inspection Note No: _____
Historic Building Maintenance Checklist for Building S6237, Fort Carson

Prepared by: _____

Type of Work

- Repair Preventive Maintenance Cyclic: _____ times per _____
 Corrective Maintenance One Time Custodial

Problem (include location and elements affected): _____

Proposed Treatment (Refer to Historic Building Management Record for past treatments):

Inspection Note No: _____
Historic Building Maintenance Checklist for Building S6237, Fort Carson

Prepared by: _____

Type of Work

- Repair Preventive Maintenance Cyclic: _____ times per _____
 Corrective Maintenance One Time Custodial

Problem (include location and elements affected): _____

Proposed Treatment (Refer to Historic Building Management Record for past treatments):

Inspection Note No: _____
Historic Building Maintenance Checklist for Building S6237, Fort Carson

Prepared by: _____

Type of Work

- Repair Preventive Maintenance Cyclic: _____ times per _____
 Corrective Maintenance One Time Custodial

Problem (include location and elements affected): _____

Proposed Treatment (Refer to Historic Building Management Record for past treatments):

Historic Building Cyclic Maintenance Schedule
 Old Hospital Complex, Fort Carson
 Building No. S6237

Task	Reference Note No.	Frequency	Date last evaluated
Weather Envelope			
Roof		Annually	
Walls		Every 5 years	
Porches		Semi-annually	
Doors		Annually	
Windows		Annually	
Structural System			
Wall Exterior, (alignment)		Annually	
Foundation Exterior		Annually	
Foundation Interior		Every 5 years	
Attic Framing		Every 5 years	
Attic Floor		Every 5 years	
Exterior Detail			
Entrance stairs		Annually	
Grounds and Site			
Lawns		Semi-annually	
Planting		Semi-annually	
Sidewalks		Semi-annually	

Inspection Note No: _____
Historic Building Maintenance Checklist for Building S6237, Fort Carson

Prepared by: _____

Type of Work

- Repair Preventive Maintenance Cyclic: _____ times per _____
 Corrective Maintenance One Time Custodial

Problem (include location and elements affected): _____

Proposed Treatment (Refer to Historic Building Management Record for past treatments):

Inspection Note No: _____
Historic Building Maintenance Checklist for Building S6237, Fort Carson

Prepared by: _____

Type of Work

- Repair Preventive Maintenance Cyclic: _____ times per _____
 Corrective Maintenance One Time Custodial

Problem (include location and elements affected): _____

Proposed Treatment (Refer to Historic Building Management Record for past treatments):

Inspection Note No: _____
Historic Building Maintenance Checklist for Building S6237, Fort Carson

Prepared by: _____

Type of Work

- Repair Preventive Maintenance Cyclic: _____ times per _____
 Corrective Maintenance One Time Custodial

Problem (include location and elements affected): _____

Proposed Treatment (Refer to Historic Building Management Record for past treatments):

