

Report No. CG-D-17-97

**SHIPPING STUDY I - A**

**A Study of the Introduction of Aquatic Nuisance Species by  
Vessels Entering the Great Lakes and Canadian Waters  
Adjacent to the United States**

**National Biological Invasions Shipping Study (NABISS)**

Donald M. Reid  
James T. Carlton

Maritime Studies Program  
Williams College - Mystic Seaport  
P.O. Box 6000  
Mystic, CT 06355



FINAL REPORT  
March 1997

This document is available to the U.S. public through the  
National Technical Information Service, Springfield, Virginia 22161

Prepared for:

U.S. Department of Transportation  
United States Coast Guard  
Marine Safety and Environmental Protection, (G-M)  
Washington, DC 20593-0001

and

U.S. Coast Guard  
Research and Development Center  
1082 Shennecossett Road  
Groton, CT 0634-6096

19970521 038

**DTIC QUALITY INSPECTED 1**

# NOTICE

This document is disseminated under the sponsorship of the Department of Transportation in the interest of information exchange. The United States Government assumes no liability for its contents or use thereof.

The United States Government does not endorse products or manufacturers. Trade or manufacturers' names appear herein solely because they are considered essential to the object of this report.

The contents of this report reflect the views of the Coast Guard Research & Development Center. This report does not constitute a standard, specification, or regulation.

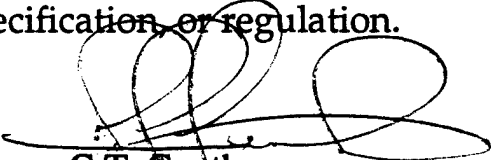

  
G.T. Gunther  
Commanding Officer  
United States Coast Guard  
Research & Development Center  
1082 Shennecossett Road  
Groton, CT 06340-6096

1. Report No. <b>CG-D-17-97</b>		2. Government Accession No.		3. Recipient's Catalog No.	
4. Title and Subtitle <b>SHIPPING STUDY 1 - A, A Study of the Introduction of Aquatic Nuisance Species by Vessels Entering the Great Lakes and Canadian Waters Adjacent to the United States</b>				5. Report Date March 1997	
				6. Performing Organization Code	
7. Author(s) Donald M. Reid and James T. Carlton				8. Performing Organization Report No. R&DC 05/97	
9. Performing Organization Name and Address Williams College - Mystic Seaport 75 Greenmanville Avenue, Mystic, CT 06355 Marine Studies Program				10. Work Unit No. (TRAIS)	
				11. Contract or Grant No. DTCG-91-F-HMR-337-1	
12. Sponsoring Agency Name and Address  U.S. Coast Guard Research and Development Center 1082 Shennecossett Road Groton, CT 06340-6096				13. Type of Report and Period Covered Final Report	
				14. Sponsoring Agency Code Commandant (G-MOR) U.S. Coast Guard Headquarters Washington, DC 20593-0001	
15. Supplementary Notes  This report was mandated by U.S. Public Law 101-646 (29 November 1990). The program was facilitated by the National Sea Grant College Program/Connecticut Sea Grant Project R/ES-6. The R&DC technical point of contact is Dr. Robert Hiltabrand, 860-441-2701.					
16. Abstract  This study investigated the extent to which shipping contributes to the introduction of nonindigenous species into the Great Lakes and adjacent Canadian ports (Canadian Great Lakes as well as east and west coast ports), potential options for controlling such introductions, and the issue of whether this problem is of regional or national concern. It complements "The Shipping Study - The Role of Shipping in the Introduction of Nonindigenous Aquatic Organisms to the Coastal Waters of the United States (other than the Great Lakes) and an Analysis of Control Options" (Carlton et al., 1995). Data on shipping traffic patterns and ballast water management practices were collected, and estimates were made of the amount and sources of ballast water released in the Great Lakes and adjacent Canadian ports. The combined results from this study with those from Shipping Study I provide a comprehensive picture of the overall ballast water picture for North America.					
17. Key Words ballast water exotic species nonindigenous ballast water exchange ballast water control			shipping study zebra mussels ballast sediments invasions		18. Distribution Statement  This document is available to the U.S. public through the National Technical Information Service, Springfield, VA 22161.
19. Security Classif. (of this report)  UNCLASSIFIED		20. SECURITY CLASSIF. (of this page)  UNCLASSIFIED		21. No. of Pages	22. Price

# METRIC CONVERSION FACTORS

## Approximate Conversions to Metric Measures

Symbol	When You Know	Multiply By	To Find	Symbol
<b>LENGTH</b>				
in	inches	* 2.5	centimeters	cm
ft	feet	30	centimeters	cm
yd	yards	0.9	meters	m
mi	miles	1.6	kilometers	km
<b>AREA</b>				
in <sup>2</sup>	square inches	6.5	square centimeters	cm <sup>2</sup>
ft <sup>2</sup>	square feet	0.09	square meters	m <sup>2</sup>
yd <sup>2</sup>	square yards	0.8	square meters	m <sup>2</sup>
mi <sup>2</sup>	square miles	2.6	square kilometers	km <sup>2</sup>
	acres	0.4	hectares	ha
<b>MASS (WEIGHT)</b>				
oz	ounces	28	grams	g
lb	pounds	0.45	kilograms	kg
	short tons (2000 lb)	0.9	tonnes	t
<b>VOLUME</b>				
tsp	teaspoons	5	milliliters	ml
tbsp	tablespoons	15	milliliters	ml
fl oz	fluid ounces	30	milliliters	ml
c	cups	0.24	liters	l
pt	pints	0.47	liters	l
qt	quarts	0.95	liters	l
gal	gallons	3.8	liters	l
ft <sup>3</sup>	cubic feet	0.03	cubic meters	m <sup>3</sup>
yd <sup>3</sup>	cubic yards	0.76	cubic meters	m <sup>3</sup>
<b>TEMPERATURE (EXACT)</b>				
°F	Fahrenheit temperature	5/9 (after subtracting 32)	Celsius temperature	°C

\* 1 in = 2.54 (exactly).

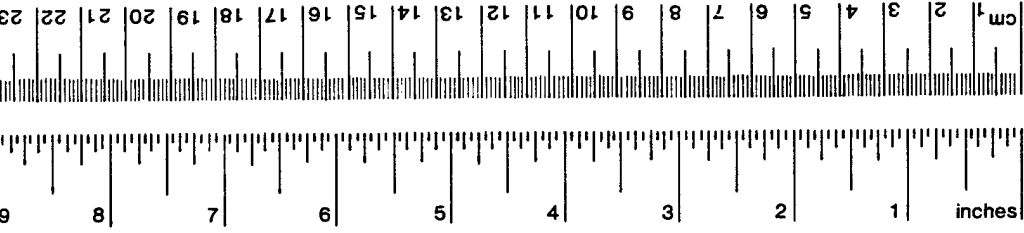

## Approximate Conversions from Metric Measures

Symbol	When You Know	Multiply By	To Find	Symbol
<b>LENGTH</b>				
mm	millimeters	0.04	inches	in
cm	centimeters	0.4	inches	in
m	meters	3.3	feet	ft
m	meters	1.1	yards	yd
km	kilometers	0.6	miles	mi
<b>AREA</b>				
cm <sup>2</sup>	square centimeters	0.16	square inches	in <sup>2</sup>
m <sup>2</sup>	square meters	1.2	square yards	yd <sup>2</sup>
km <sup>2</sup>	square kilometers	0.4	square miles	mi <sup>2</sup>
ha	hectares (10,000 m <sup>2</sup> )	2.5	acres	ac
<b>MASS (WEIGHT)</b>				
g	grams	0.035	ounces	oz
kg	kilograms	2.2	pounds	lb
t	tonnes (1000 kg)	1.1	short tons	st
<b>VOLUME</b>				
ml	milliliters	0.03	fluid ounces	fl oz
l	liters	0.125	cups	c
l	liters	2.1	pints	pt
l	liters	1.06	quarts	qt
l	liters	0.26	gallons	gal
m <sup>3</sup>	cubic meters	35	cubic feet	ft <sup>3</sup>
m <sup>3</sup>	cubic meters	1.3	cubic yards	yd <sup>3</sup>
<b>TEMPERATURE (EXACT)</b>				
°C	Celsius temperature	9/5 (then add 32)	Fahrenheit temperature	°F

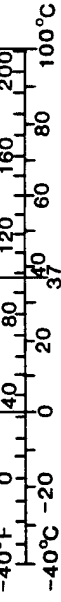

## TABLE OF CONTENTS

	<u>Page</u>
LIST OF FIGURES .....	vii
LIST OF TABLES .....	viii
ACRONYMS AND ABBREVIATIONS .....	x
EXECUTIVE SUMMARY.....	xi
INTRODUCTION.....	1
METHODS .....	2
<i>DATA</i> .....	2
Great Lakes Ports.....	2
St. Lawrence River Ports .....	3
Canadian Coastal Ports .....	3
<i>ANALYSIS</i> .....	3
Great Lakes Ports.....	4
St. Lawrence River Ports .....	7
East Coast Ports .....	8
West Coast Ports .....	9
Vancouver.....	9
Prince Rupert .....	10
RESULTS .....	10
Great Lakes Ports .....	10
St. Lawrence River Ports.....	14
East Coast Ports .....	15
Halifax .....	15
St. John .....	15
St. John's.....	16
West Coast Ports.....	16
Vancouver .....	16
Prince Rupert.....	17

## TABLE OF CONTENTS

Comparison of Ballast Water Quantities Discharged.....	17
Comparison of Ballast Water Quantities Carried into Ports/Destinations .....	17
DISCUSSION.....	18
Great Lakes.....	18
Last Port of Call by FAO Region.....	22
Riverport .....	22
Coastal Ports.....	23
Vancouver Port .....	23
Total Discharged .....	23
Total Carried .....	23
LITERATURE CITED .....	24
FIGURES 1 - 19 .....	25
TABLES 1 - 42.....	45

## LIST OF FIGURES

<u>Figure</u>		<u>Page</u>
1	LPOC by FAO region for ships from foreign ports - Great Lakes.....	25
2	LPOC by FAO region for ships from foreign ports - Detroit .....	26
3	LPOC by FAO region for ships from foreign ports - Chicago.....	27
4	LPOC by FAO region for ships from foreign ports - Cleveland .....	28
5	LPOC by FAO region for ships from foreign ports - Duluth/Superior.....	29
6	LPOC by FAO region for ships from foreign ports - Hamilton .....	30
7	LPOC by FAO region for ships from foreign ports - Windsor .....	31
8	LPOC by FAO region for ships from foreign ports - Sarnia.....	32
9	LPOC by FAO region for ships from foreign ports - Thunder Bay .....	33
10	Ballast water source by FAO region. Unacknowledged ballast from foreign ports - Great Lakes.....	34
11	Ballast water source by FAO region. Acknowledged ballast from foreign ports - Great Lakes.....	35
12	LPOC by FAO region for ships from foreign ports - Riverport .....	36
13	LPOC by FAO region for ships from foreign ports - Halifax.....	37
14	LPOC by FAO region for ships from foreign ports - St. John .....	38
15	LPOC by FAO region for ships from foreign ports - St. John's.....	39
16	LPOC by FAO region for ships from foreign ports - Vancouver .....	40
17	LPOC by FAO region for ships from foreign ports - Prince Rupert.....	41
18	Ballast water discharged in the Great Lakes and selected ports .....	42
19	Ballast water discharged (log scale) in the Great Lakes and selected ports.....	43

## LIST OF TABLES

<u>Table</u>	<u>Page</u>
1 Vessel and ballast data (All) - entering the St. Lawrence Seaway in 1991 .....	45
2 Vessel and ballast data (Acknowledged) - entering the Seaway .....	46
3 Vessel and ballast data (Unacknowledged) entering the Seaway .....	47
4 Vessel, BOB and DIS data (All) - entering the Seaway .....	48
5 Vessel data, BOB and DIS (Acknowledged) - entering the Seaway .....	49
6 Vessel data, BOB and DIS (Unacknowledged) - entering the Seaway .....	50
7 Calculated ballast related to GRT (Acknowledged) - entering the Seaway. ....	51
8 Calculated ballast related to GRT (Unacknowledged) - entering the Seaway .....	52
9 Calculated BOB related to BWCAP (Acknowledged) - entering the Seaway .....	53
10 Calculated BOB related to BCWAP (Unacknowledged) - entering the Seaway. ....	54
11 Calculated DIS related to BOB (Acknowledged) - entering the Seaway .....	55
12 Calculated DIS related to BOB (Unacknowledged) - entering the Seaway .....	56
13 DIS (Acknowledged) - entering the Seaway in transit to the Great Lakes and the listed ports. ....	57
14 DIS (Unacknowledged) - entering the Seaway in transit to the Great Lakes and the listed ports. ....	58
15 DIS (Acknowledged) - entering the Seaway in transit to the Great Lakes and the listed ports. ....	59
16 DIS (Unacknowledged - entering the Seaway in transit to the Great Lakes and the listed ports.....	60
17 Vessel Arrivals: #ARR, #BT and %BT (Acknowledged) - all Great Lakes ports .....	61
18 Acknowledged ballast by source (FAO Waters of the World: A, C, G) entering the Seaway .....	62
19 Unacknowledged ballast by source (FAO Water of the World: A, C, G) entering the Seaway .....	63
20 Sources (FAO Water of the World: A,B,C) and intended DIS the Great Lakes ports indicated.....	64

## LIST OF TABLES

<u>Table</u>	<u>Page</u>
21 Vessel data (Acknowledged & Unacknowledged) - St. Lawrence Riverport .....	65
22 Vessel data (Acknowledged) - St. Lawrence Riverport.....	66
23 Vessel data (Unacknowledged)- St. Lawrence Riverport .....	67
24 Mean quantities and BWCAP (Acknowledged) - St. Lawrence Riverport .....	68
25 Mean quantities and BWCAP (Unacknowledged) - St. Lawrence River ports .....	69
26 Estimated DIS (Acknowledged) - the Riverport.....	70
27 Estimated DIS (Unacknowledged) - the Riverport.....	71
28 Mean GRT (Acknowledged & Unacknowledged) - Halifax . .....	72
29 Estimated DIS (Acknowledged) - Halifax .....	73
30 Estimated DIS (Acknowledged) - Halifax .....	74
31 Mean GRT (Acknowledged & Unacknowledged) - St. John .....	75
32 Estimated DIS (Acknowledged) - St. John.....	76
33 Estimated DIS (Unacknowledged) - St. John .....	77
34 Mean GRT (Acknowledged and Unacknowledged) - St. John's .....	78
35 Estimated DIS (Acknowledged) - St. John's .....	79
36 Estimated DIS (Unacknowledged) - St. John's.....	80
37 Estimated DIS (Acknowledged & Unacknowledged) - Vancouver.....	81
38 Estimated DIS (Acknowledged & Unacknowledged) - Prince Rupert.....	82
39 Estimated intended DIS for all vessels - the Great Lakes and listed ports. ....	83
40 Estimated BOB (Acknowledged & Unacknowledged) - to listed destinations .....	84
41 Total estimated volumes of foreign ballast water arriving in the Great Lakes.....	85
42 Total estimated volumes of foreign ballast water arriving in Canadian coastal ports. ....	86

## ACRONYMS AND ABBREVIATIONS

A.....	Acknowledged Ballast
ALL .....	All Vessel Types
BOB.....	Ballast on Board
BULK.....	Bulk Carrier
BWCAP.....	Ballast Water Capacity
BWER .....	Ballast Water Exchange Report
CF.....	Conversion Factor
CGL.....	Canadian Great Lakes
CGLBWCG .....	Canadian Great Lakes Ballast Water Control Guidelines
CONT.....	Container Carrier
DIS.....	Ballast Water Intended for Discharge
DV .....	Dependent Variable
ECAREG.....	Eastern Canadian Region
FAO.....	United Nations Food and Agriculture Organization
GC .....	General Cargo Carrier
GL .....	Great Lakes
GLBWCG.....	Great Lakes Ballast Water Control Guidelines
GRT.....	Gross Register Tonnage
IV .....	Independent Variable
LPOC .....	Last Port of Call
MD .....	Mean Discharge
MEAN .....	Average of the Sample
MT.....	Metric Ton (Tonne)
N.....	Number of Observations
NABISS .....	National Biological Invasions Shipping Study
NBWCP.....	National Ballast Water Control Program
NOBOB.....	No Ballast on Board
NPOC.....	Next Port of Call
NRT.....	Net Register Tonnage
RP.....	Riverport
SLSA.....	Saint Lawrence Seaway Authority
STD .....	Standard Deviation of the Sample
SUM.....	Total of Observations
TANK.....	Tanker
UA.....	Unacknowledged Ballast
USGL.....	United States Great Lakes
VTS .....	Vessel Traffic Services

## EXECUTIVE SUMMARY

This study complements "The Shipping Study I" (Carlton et al., 1995) with work continuing under the National Biological Invasions Shipping Study (NABISS). Shipping Study I examined the degree to which shipping may be a major pathway of transmission of aquatic nuisance species to U.S. coastal ports. It documented vessel traffic and ballast water transport in Atlantic, Gulf, and Pacific ports, including Hawaii and Alaska. The intent of this study was to produce similar information for the U.S. Great Lakes ports and adjacent Canadian ports to develop an overall ballast water picture for North America.

Data were collected on the shipping traffic patterns and ballast water management practices conducted by large vessels entering U.S. Great Lakes ports and adjacent Canadian ports. The ports were selected based on the number of foreign vessel arrivals in 1991. Sources for the data included the U.S. Bureau of Census TM385, Shipping in Canada Catalogue 54-205, Lloyd's Register, St. Lawrence Seaway Authority, Canadian Coast Guard's Ballast Water Exchange Reports and Vessel Traffic Services' Eastern Canadian Region database.

Estimates of the amount and sources of ballast water released were derived using a similar extrapolation method used in Shipping Study I. The results of this study determined that vessels arriving in the Great Lakes and listed ports in 1991 discharged an estimated 47,039,926 MT of foreign ballast water. The Northeast Atlantic ports of northern Europe were the predominant origin of the foreign ballast water (46.8%), followed by Mediterranean Sea ports (14.1%).

Four types of vessels for which data were collected included bulk carriers, general cargo carriers, tankers and container carriers. The study determined that bulk carriers were responsible for most of the ballast water discharged in 1991. While other vessel types discharged smaller quantities of ballast water, they typically carried mixed cargoes, were more likely to visit multiple ports, and therefore were more likely to conduct ballast operations in several ports. Whether the chance of a

nonindigenous species introduction is more likely where large volumes of water are discharged, or where multiple inoculations occur, is unknown.

The current study also determined that large amounts of ballast water moved into and between ports within the Great Lakes by lakers (cargo vessels that travel exclusively in the Great Lakes and the St. Lawrence Seaway). It is readily apparent that once a nonindigenous species has been introduced into the Great Lakes, there would be ample opportunity for many vessels to secondarily spread the organisms to other areas of the Great Lakes, and for the Great Lakes to become an exporter of species proven to be capable invaders.

To determine the overall ballast water picture for North America in 1991, extrapolations from Shipping Study I were combined with those from the current study. Data from this study estimated that 47,925,638 MT of ballast water were carried into Canadian coastal ports in 1991. Combined with the 1,395,461 MT estimated as carried into the Great Lakes and the 57,690,000 MT estimated for coastal U.S. ports in Shipping Study I results in a combined U.S.-Canadian estimate of 107,011,099 MT.

## INTRODUCTION

In response to a number of introductions of nonindigenous species into the North American Great Lakes, particularly the zebra mussel *Dreissena polymorpha*, the U.S. Congress passed Public Law 101-646 (November 29, 1990), the "Nonindigenous Aquatic Nuisance Prevention and Control Act of 1990 (Bederman, 1991). The "National Ballast Water Control Program" (NBWCP) was established under Section 1102 of this act. This program identified the need for "Studies on Introduction of Aquatic Nuisance Species by Vessels" and called for the "Shipping Study", defined as:

"a study to determine the need for controls on vessels entering waters of the United States, other than the Great Lakes, to minimize the risk of unintentional introduction and dispersal of aquatic nuisance species in those waters."

As in the Shipping Study (hereafter, Shipping Study I), we use the term "nonindigenous species" rather than "aquatic nuisance species" to refer to organisms carried by vessels. Shipping Study I (Carlton et al., 1995) included an examination of "the degree to which shipping may be a major pathway of the transmission of aquatic nuisance species in those waters". It documented vessel traffic and ballast water transport in U.S. coastal (Atlantic, Gulf, Pacific, Hawaii and Alaska) ports in 1991. The intent of the current study is to produce similar information for the U.S. Great Lakes ports and "adjacent" Canadian ports (Canadian Great Lakes as well as East and West Coast ports) to develop an overall ballast water picture for North America.

This report complements "The Shipping Study I" (Carlton et al., 1995) with the work continuing under the National Biological Invasions Shipping Study (NABISS) which has continued operating through the laboratory of Dr. James T. Carlton of the Williams College - Mystic Seaport Maritime Studies Program in Mystic, Connecticut. This report addresses Section 207 of the Coast Guard Authorization Act of 1989 (Public Law 101-225) to "Report on Control of Exotic Species" in U.S. waters, including the Great Lakes. Shipping Study I, in conjunction with the current report, responds to both Acts.

## METHODS

### DATA

#### Great Lakes Ports

The Great Lakes were studied both as a unit and as a collection of selected ports, four from the United States and four from Canada. The U.S. Great Lakes ports were chosen based on the number of foreign (non-U.S. and Canadian registered) vessel arrivals in 1991 from U.S. Bureau of Census data (TM385, Vessel Arrivals, 1991 ). This listing supplied information on ballast condition (in ballast; carrying acknowledged ballast or not in ballast; carrying unacknowledged ballast as defined in Shipping Study I) and Last Port of Call (LPOC) for vessels entering the selected U.S. ports. Due to the relatively limited numbers of international vessels sailing the Great Lakes (compared to many U.S. coastal ports; see Shipping Study I), this database was not as useful for the current report as it proved to be in Shipping Study I.

Canadian Great Lakes ports were chosen based on the number of international vessel arrivals as recorded in Statistics Canada data (Shipping in Canada, Catalogue 54-205, 1991). Individual vessels entering the Seaway were identified by St. Lawrence Seaway Authority (SLSA) data, derived from information collected on vessels as they entered and departed the Seaway. All vessels entering the Seaway at Lock #1 at St. Lambert PQ, were recorded in this database, whether their final destination was a port on the St. Lawrence River anywhere above the first lock, or one of the Great Lakes ports (both U.S. and Canadian). Port visits by vessels in the Upper St. Lawrence River and Great Lakes were recorded in the SLSA database as cargo destinations listed for vessels entering the Seaway and as the origins of cargo carried by vessels departing the Seaway. Upbound vessels with no cargo destinations and downbound vessels with no cargo origins were therefore traveling in ballast for that part of the journey. In ballast vessels carried "acknowledged ballast", while in cargo vessels carried "unacknowledged ballast" as defined in Shipping Study I.

The Pollution Section of the Ship Safety Branch of the Canadian Coast Guard supplied data derived from Ballast Water Exchange Reports (BWERs) received from vessels entering the St. Lawrence Seaway and collected by the SLSA.

The Eastern Canadian Region (ECAREG) offices of Vessel Traffic Services (VTS) supplied information collected from vessels as they approached Canadian waters.

Vessels transiting the St. Lawrence River to Quebec City and beyond were routinely asked specific questions about their ballast water relating to the Canadian Great Lakes Ballast Water Control Guidelines (GLBWCG). For listed vessels, this database was also useful for identifying vessels carrying acknowledged ballast water (cargo recorded as ballast).

### **St. Lawrence River Ports**

All vessels recorded as traveling at least as far inland as Quebec City in the ECAREG database, but not recorded as having entered the Seaway in the SLSA database, were combined into a "Riverport" category. Although all vessels in this category would have had a single port (e.g., Montreal) recorded as its next Port of Call (NPOC), many vessels could have had several scheduled stops (e.g., Trois Rivieres, Quebec City, Sorel and/or Montreal). This category therefore includes all vessels entering the Upper St. Lawrence River from Quebec City to Montreal inclusive regardless of the specific port or ports of destination.

### **Canadian Coastal Ports**

Canadian coastal ports were chosen based on the number of international vessel arrivals as recorded in Statistics Canada data (Shipping in Canada, Catalogue 54-205, 1991 ).

Detailed information on vessel traffic was made available for Canadian East Coast ports by Vessel Traffic Services (VTS; Canadian Coast Guard). Additional information on vessel traffic and port operations (vessel/cargo statistics, annual reports, etc.) was received from Port Corporation offices in individual ports. Some data on individual vessels were received from the ports of St. John, NB; St. John's, NF; Halifax, NS; and Prince Rupert, BC. Individual vessel data were not available for Vancouver from any of the identified sources.

### ***ANALYSIS***

Specific data supplied by the above listed governmental and private agencies and organizations (on disc, microfiche or hardcopy) were translated to or manually entered into QuattroPro worksheet files for handling and analysis. All calculations were also conducted on QuattroPro. The number of vessels visiting the ports identified for this study was, in general, substantially fewer than for the level of activity seen in many of the ports in Shipping Study I. This allowed all port visits

by all designated vessels to be included in this analysis, rather than a subsample as was required in Shipping Study I.

Information such as vessel type, gross register tonnage (GRT), etc., were variously recorded in the databases. Additional records, including ballast water capacities (BWCAP: in metric tons, where available) were obtained from Lloyd's Register. BWCAP for some vessels was also available from previous studies on vessels entering the St. Lawrence Seaway (Locke et al., 1991, 1992; unpublished data).

The vessel's Last Port of Call (LPOC) or source of ballast water, where recorded, were coded according to the Food and Agricultural Organization, United Nations (FAO) Waters of the World (see Shipping Study I). LPOCs (as recorded) were not necessarily the vessel's actual previous port before arrival, but were accepted as indicative of the region of origin. For example, a vessel that originated in Riga and subsequently made stops at Bremen, Antwerp, and Liverpool may have reported Riga or Liverpool as the LPOC. However, within the FAO Waters of the World regions, all these ports are located in region "B".

Information was transferred between databases as required. For example, one database may have recorded a vessel's LPOC as France, or may have no location recorded, while another database recorded the LPOC as Fos, allowing this vessel's LPOC to be categorized as area "C" (the Mediterranean and adjacent waters) in the FAO Waters of the World. Similarly Montreal, the port which vessels necessarily pass through to enter the St. Lawrence Seaway, was recorded as the LPOC of many vessels entering the Great Lakes in some databases. For the purposes of this study, the port visit prior to entry into the Laurentian - Great Lakes System) was taken as the LPOC.

Additional regions were included where necessary for clarification. These included the Riverport (RP), Great Lakes (GL), U.S. and Canadian Great Lakes ports (USGL and CGL respectively).

### **Great Lakes Ports**

For each vessel identified in the St. Lawrence Seaway Authority records for 1991, Net and Gross Register Tonnage (NRT and GRT respectively), and ballast water capacity (BWCAP) were recorded from Lloyd's Register, tabulated, and the number

of vessel records (observations, N), total of observations (SUM), average (MEAN) and standard deviation of the sample (STD) calculated in each case. These parameters were determined for all vessels, vessels carrying acknowledged ballast (with no cargo), and vessels carrying unacknowledged ballast (i.e., with some combination of ballast water and cargo or traveling in cargo with only residual ballast water). Within each of these categories, the parameters were determined for all vessels (ALL), bulk carriers (BULK), general cargo carriers (GC) and tankers (TANK).

For vessels that submitted Ballast Water Exchange Reports (BWERs), NRT, GRT and BWCAP (from Lloyd's Register) were again tabulated for all vessels, vessels carrying acknowledged or unacknowledged ballast and analyzed as above (N, SUM, MEAN, STD). Quantities of ballast water on board (BOB) and ballast water intended for discharge (DIS) were also often recorded. Within each category, the parameters were analyzed for each of the major vessel types as noted above: ALL, BULK, GC and TANK.

In order to determine relationships between various vessel and ballast water parameters, regression analyses were conducted (on paired data) for vessels carrying acknowledged or unacknowledged ballast (see above). In each case, the mean of the independent variable (IV; e.g., GRT) was inserted into the resulting regression equation to estimate the mean of the corresponding dependent variable (DV; e.g., BWCAP). A percentage relationship between the parameters was then calculated by the equation  $(DV/IV) \times 100$  (e.g.,  $(BWCAP / GRT) \times 100$ ). The number of IV/DV pairs were recorded (N), and R-squared was calculated in each case to show the strength of the relationship. Regressions were calculated as follows: BWCAP onto GRT, BOB onto BWCAP, and DIS onto BOB.

Data from both sources (SLSA and BWERs) were combined to estimate the total quantity of ballast water intended for discharge in the Great Lakes, and the amount expected to be discharged in each of the eight specific ports selected for more detailed examination (information on intended ballast water operations derived from the BWERs was extrapolated to the larger SLSA data set). Quantities were determined separately for vessels carrying acknowledged and unacknowledged ballast.

Numbers of vessels (N) in each destination category and the average number of ports visited per vessel (NP) were derived from the SLSA data. GRT was recorded from Lloyd's register for vessels identified from SLSA records, and averaged over all vessels in each category. A conversion factor (CF) was calculated by multiplying together the appropriate percentage values derived from the regressions above relating BWCAP to GRT, BOB to BWCAP, and DIS to BOB. The average amount of ballast water intended for discharge per vessel (MD: Mean Discharge) in each port was calculated by the following equation:  $MD = (GRT \times CF) / NP$ . The estimated total quantity of ballast water intended for discharge was determined by multiplying this number by the appropriate N for each destination.

The CFs determined above also allowed estimates of the quantities of ballast water intended for discharge by the major vessel types (ALL, BULK, GC, TANK) carrying acknowledged or unacknowledged ballast that entered the Great Lakes and each selected port. This was calculated from the mean GRT of each vessel type for each port, and adjusted for the average number of port visits (as above).

The number of vessel arrivals, the number of arrivals in ballast, and the percentage of vessel arrivals in ballast were calculated for each of the specified Great Lakes ports from both St. Lawrence Seaway Authority data and Bureau of Census data. This allowed a comparison of ballast condition between vessels entering the St. Lawrence Seaway en route to the Great Lakes and vessels subsequently entering U.S. ports.

Last Port of Call (LPOC) was coded to the FAO Waters of the World regions for each vessel. Numbers of vessels from each region were totaled to determine the relative importance of the various areas as sources of vessels bound for the Great Lakes. This was determined for all vessels as they entered the Great Lakes, and for all vessels that entered each of the specified U.S. and Canadian Great Lakes ports (from SLSA data).

Actual sources of ballast water were often recorded on the BWERs, allowing the ballast water carried by all vessels with acknowledged or unacknowledged ballast to be categorized by FAO source area (see Shipping Study I). The quantities of ballast water intended for discharge in the Great Lakes and each of the Great Lakes ports included in this study were also categorized by FAO source area.

## St. Lawrence River Ports

NRT, GRT and BWCAP were recorded from Lloyd's Register for each vessel identified in the ECAREG records for 1991, tabulated, and N, SUM, MEAN and STD calculated in each case (see above). These parameters were determined for all vessels, vessels carrying acknowledged ballast, and vessels carrying unacknowledged ballast. Within each of these categories, the parameters were determined for all major vessel types as described above (ALL, BULK, GC and TANK), with the addition of container carriers (CONT).

In order to estimate the quantity of ballast water discharged in the St. Lawrence "Riverport" in 1991, regression equations relating BWCAP to GRT for vessels with acknowledged or unacknowledged ballast were derived (as above for Great Lakes vessels). Since the locks of the St. Lawrence Seaway limit the size of vessels proceeding upstream of Montreal, it was felt that basing Riverport estimates on the regressions relating BWCAP to GRT for Great Lakes bound vessels could underestimate GRT and BWCAP (physical parameters that remain constant in each vessel), and hence BOB and DIS for Riverport vessels. Since BWERs were not available for Riverport bound vessels, new regressions to determine CFs relating BOB to BWCAP and DIS to BOB based on Riverport vessels could not be estimated. The CFs relating these parameters determined above for Great Lakes vessels were therefore used to estimate BOB and DIS based upon the BWCAP of Riverport vessels. Since BOB and DIS are related to ballast water operations rather than vessel construction, the relationships as seen in Great Lakes vessels were regarded as acceptable estimates for Riverport vessels.

A conversion factor (CF) was calculated by multiplying together the appropriate percentage values relating BWCAP to GRT, BOB to BWCAP, and DIS to BOB (as above) for all vessels and for each vessel type. The average amount of ballast water intended for discharge per vessel (MD: Mean Discharge) was calculated by the equation  $MD = GRT \times CF$ . Since the Riverport was considered a single port, no adjustment was necessary for multiple port visits. The estimated total quantity of ballast water intended for discharge was determined by multiplying MD by the appropriate N (number of vessels) for each vessel type. Insufficient information was available to fully determine similar CFs for tankers. In the case of tankers carrying acknowledged ballast, the CF for "ALL" vessels was used. For tankers carrying unacknowledged ballast, sufficient information was available to calculate the CF

using the tanker percentages relating BWCAP to GRT and BOB to BWCAP, and the ALL vessels CF relating BOB to DIS.

Since container carriers were not recorded as having entered the Great Lakes, the estimate of DIS by container carriers in ports was taken from Shipping Study I. Container carriers do not typically travel in ballast (see Shipping Study I for the discussion on ballast operations in container carriers), so the estimated DIS of 303 MT was used here for container carriers with ballast, that is, carrying unacknowledged ballast water.

### **East Coast Ports**

Vessel information was recorded in data supplied by the Canadian Coast Guard (ECAREG) for the three East Coast ports selected in this study: Halifax, St. John and St. John's. GRT for each vessel was recorded in the ECAREG records for 1991, tabulated, and number of observations (N), total of observations (SUM), average (MEAN) and standard deviation of the sample (STD) calculated for each port. These parameters were determined for all vessels, vessels carrying acknowledged ballast and vessels carrying unacknowledged ballast. Within each of these categories, the parameters were determined for ALL, BULK, GC and TANK vessels. Since CONT vessels rarely travel in ballast and vessels carrying empty containers could be recorded as in ballast, data for container carriers were only calculated for ALL vessels, and these were subsequently considered as carrying unacknowledged ballast in later calculations (e.g., estimates of ballast water discharged).

Estimates of ballast water discharged were determined using Mean GRTs as calculated for each port and CFs as determined above for the Riverport. Since there were no structural restrictions (e.g., locks of the St. Lawrence Seaway for vessels entering the Great Lakes) to vessels bound for the Riverport, it was felt that CFs relating DIS to GRT for similarly loaded vessels (carrying acknowledged or unacknowledged ballast) would be comparable between the Riverport and the East Coast ports.

The Last Port of Call for each vessel (LPOC) was recorded (as country) in the ECAREG database. These were coded according to the FAO Waters of the World (see above). Numbers of vessels from each region were totaled to determine the relative importance of the various areas as sources of vessels bound for each port.

## West Coast Ports

### Vancouver

Information on individual vessels entering Vancouver were not available from any of the identified data sources. The Vancouver Port Corporation supplied information on the number of foreign vessel arrivals and total GRT of foreign arrivals. Mean GRT was determined by dividing total GRT by the number of vessels.

There were no available records indicating ballast condition (carrying acknowledged or unacknowledged ballast) or LPOC of arriving vessels. However, cargo tonnage statistics showed that in 1991, Vancouver exported 60,664,000 MT and imported only 3,188,000 MT of cargo. Exports consisted of 95.0% of the total cargo handled. Since bulk exports comprised 86% of the total cargo tonnage handled in the port (imports and exports), and almost all of the bulk carriers would have been expected to arrive in ballast (see Shipping Study I), the remaining 10% was sufficient to represent those vessels that arrived with cargo for unloading and those that arrived partially loaded to load additional cargo (carrying unacknowledged ballast). The Harbour Master's office of the Vancouver Port Corporation also estimated that 90% of their traffic was bulk carriers arriving to load cargo. It was therefore accepted that 90% would represent a slightly conservative estimate of the proportion of vessels that arrived in ballast.

The estimated mean volume of ballast water discharged (DIS) was calculated by multiplying the mean GRT by the appropriate CFs relating DIS to GRT for vessels carrying acknowledged or unacknowledged ballast as determined above. DIS was then multiplied by the number of vessels in each ballast category to estimate the total quantity of ballast water discharged by each category.

Since no LPOC information was available for Vancouver, it was felt that presenting total cargo (import and export) metric tonnage data with Vancouver's Principal Trading Countries (from Vancouver Port Corporation data) would give the best representation of vessel origins. Vessels from U.S., U.S.S.R. and other Canadian ports were accepted as originating in Pacific ports.

## Prince Rupert

Some information on individual vessels was available from the Prince Rupert Port Corporation. GRT and LPOC (by country) were recorded, and vessel type was taken from Lloyd's Register. Again, no indication of ballast condition (carrying acknowledged or unacknowledged ballast) was recorded, although Prince Rupert is almost entirely an export port indicating that most vessels arrive in ballast.

In 1991, Prince Rupert exported 12,827,735 MT of cargo (virtually all bulk cargo), and imported 929 MT of cargo (virtually all general cargo) on foreign traffic vessels (data from Prince Rupert Port Corporation). Taking 90% of inbound vessels as in ballast was considered a conservative estimate for vessels arriving at Prince Rupert (as for Vancouver above). The 10% excluded more than allowed for those vessels that unloaded cargo or arrived partially loaded to load additional cargo (carrying unacknowledged ballast).

LPOC, recorded (as country) in the Prince Rupert Port Corporation's database, were coded according to the FAO Waters of the World (see above). Numbers of vessels from each region were totaled to determine the relative importance of the various areas as sources of vessels bound for Prince Rupert.

The CFs derived above were also used to estimate the quantity of ballast water carried into each port/destination to allow direct comparison with Shipping Study I and Locke et al. (1991).

## **RESULTS**

### **Great Lakes**

Basic vessel data net and gross register tonnage (NRT and GRT respectively), and ballast water capacity (BWCAP) are presented for all vessels (Table 1), vessels carrying acknowledged (Table 2) and unacknowledged ballast (Table 3). Of the 427 vessels recorded in the St. Lawrence Seaway Authority records for 1991, 143 (33%) entered the Seaway in ballast (carrying no cargo) (Table 2). The remaining 284 vessels (67%) entered the Seaway with some combination of cargo and ballast water on board, or in cargo and carrying only a small quantity of residual ballast water (carrying unacknowledged ballast) (Table 3).

Of all vessels entering the Seaway, 34% of bulk carriers (for example, calculated as

92 vessels (from Table 2) divided by 267 vessels (from Table 1)), 43% of general cargo carriers and 23% of tankers entered in ballast (Tables 1 and 2). On average, bulk carriers were almost twice the size (Mean 16,022 GRT) of general cargo carriers (Mean 8,532 GRT) and tankers (Mean 8,559), and were capable of carrying much more ballast water (Mean BWCAP 11,677 MT (metric tons)) as general cargo carriers (Mean BWCAP 4,042 MT) and tankers (Mean BWCAP 5,280).

The Ballast Water Exchange Reports (BWERs) supplied some additional information on ballast water quantities, origin and intended point of discharge for ballast water carried on board. A total of 202 Ballast Water Exchange Reports (BWERs) were received by the Canadian Coast Guard's Ship Safety Section, Pollution Prevention office from foreign-registered (non-Canadian and non-U.S.) cargo vessels entering the St. Lawrence Seaway. St. Lawrence Seaway Authority records show that 427 vessels entered the seaway during the 1991 season, resulting in a return rate of 47.3%. These BWERs documented 591,630 metric tons (or tonnes: MT) of ballast water entering the seaway, an average of 2,929 MT per vessel. Intended discharge location was reported for 245,434 MT of ballast water, 41.5% of the total.

Basic vessel data (as above), actual ballast water carried on entry to the Seaway (ballast on board: BOB) and the quantity of ballast water intended for discharge in the Great Lakes (ballast water for discharge: DIS) are presented for all vessels (Table 4), vessels carrying acknowledged ballast (Table 5) and vessels carrying unacknowledged ballast (Table 6) that submitted BWERs. For all vessels and for each vessel type, DIS was greater than BOB (Table 4, comparing means of all categories). The same is also true for some of the vessel types (ALL and GC) entering the Seaway with acknowledged ballast (Table 5), but not for any of the vessel types entering the Seaway with unacknowledged ballast. This situation was created by a failure on the part of many of those vessels submitting the BWERs to fully complete the forms. Tables 4 and 5 apparently indicate that only vessels intending to discharge a considerable quantity of ballast water (in ballast or nearly in full ballast) supplied this information on the BWERs. While 79 in ballast vessels reported the quantity of ballast on board, only 34 (43%) reported the quantity they intended to discharge.

Vessels with unacknowledged ballast carried relatively small quantities of ballast

water on board, and only a portion of the ballast water carried was intended (or was known to be intended) for discharge (Table 6). Another method was therefore developed to more accurately estimate the quantity of ballast water intended for discharge in the Great Lakes and individual ports, avoiding the problems inherent in using data from different vessels (unpaired variables) and different numbers of vessels (unbalanced data).

Sequential regressions were conducted to estimate DIS based on the information available in the BWERs. Paired data were used to determine the relationships between vessel parameters (Tables 7-12). For vessels with acknowledged or unacknowledged ballast, the regression equations (arithmetic values where regressions were not possible due to small numbers of available data points), percentage values (developed as conversion factors (CFs) relating the various parameters), numbers of observations and R-squared values indicating the strength of the relationships are shown in Tables 7-12. These regressions permitted calculations of BWCAP, BOB, and DIS.

Thus, for carrying acknowledged (A) or unacknowledged (UA) ballast respectively, the regression information relating BWCAP to GRT was recorded in Tables 7 (A) and 8 (UA), BOB to BWCAP in Tables 9 (A) and 10 (UA), and DIS to BOB in Tables 11 (A) and 12 (UA). Using these data to calculate BWCAP, BOB, and DIS for bulk carriers is illustrated as follows (using the appropriate conversion factors): for bulk carriers in ballast, a 10,000 GRT vessel would be expected to have a BWCAP of about 6,390 MT (63.9% of GRT from Table 7), to have 5,687 MT BOB (89% of BWCAP from Table 9), and a DIS of 5,391 MT of ballast water while in the Great Lakes (94.8% of BOB from Table 11).

Combining vessel data information on all 427 vessels recorded in the St. Lawrence Seaway Authority records with this regression information derived from the BWERs described above, it was possible to estimate DIS for the Great Lakes and in each of the selected Great Lakes ports by an average vessel and by all vessels. Again, vessels carrying acknowledged and unacknowledged ballast were separated (Tables 13 and 14 respectively). Overall CFs produced by multiplying the individual CFs relating vessel and ballast water parameters derived above allowed the estimation of DIS directly from GRT for each location. Since many vessels visited multiple ports and may have adjusted their ballast condition in any port, the

resultant DIS quantities were further divided by the mean number of port visits each vessel type made (from St. Lawrence Seaway Authority data). This gave an estimate of DIS per vessel for each location. Multiplying DIS by the number of vessels expected to visit each location produced the total DIS for each location.

Adjusting for multiple port visits resulted in a conservative estimate of DIS for each port, but did not affect the expected DIS for the Great Lakes as a unit, since the Great Lakes as a whole were treated as a single large port. Combining DIS for vessels with acknowledged (941,226 MT; Table 13) and unacknowledged ballast (454,235 MT; Table 14) , it was estimated that 1,395,461 MT of ballast water were discharged in the Great Lakes in 1991.

Using the CFs described above, and again adjusting for multiple port visits, it was also possible to estimate DIS for vessels carrying acknowledged and unacknowledged ballast (Tables 15 and 16 respectively) in each location by major vessel type. Combining BULK, GC and TANK vessels, regardless of ballast condition, DIS for the Great Lakes was estimated at 1,375,993 MT. The latter number is slightly smaller than the total calculated above since minor vessel types (e.g., Roll-on Roll-offs) have been excluded.

Table 17 indicates that the ballast condition of a vessel may change between the time it enters the Seaway and its arrival at its destination port. For example, while 13 vessels heading for Detroit were reported in ballast at the entrance to the Seaway (St. Lawrence Seaway Authority data), 18 in ballast vessels apparently arrived at Detroit (Bureau of Census data). Over the four U.S. ports, however, this variability resulted in only slight differences in the percentage of in ballast arrivals in each port. Bureau of Census data for all four U.S. ports record slightly more foreign vessel arrivals for each port than did the St. Lawrence Seaway Authority data (Table 17). Whether this is due to multiple visits to the same port on the same trip or to some other reason is unknown.

Figures 1-9 present the relative importance of different source areas of vessels entering the St. Lawrence Seaway bound for the Great Lakes, and for the eight specified ports (St. Lawrence Seaway Authority data). In every case except for Windsor (related to the small  $n = 4$ ), the Northeast Atlantic ports (northern Europe) were the predominant origin for vessels entering the Great Lakes and Great Lakes

ports. These ports accounted for 46.8% of all vessels entering the Great Lakes; another 14.1% of all vessels originated from Mediterranean Sea ports (Figure 1).

BOB from known sources (coded by FAO Waters of the World) carried by vessels with acknowledged or unacknowledged ballast (a total of 576,496 MT; 97.4% of the total 591,630 MT documented on the BWERs) entering the Seaway are recorded in Table 18 and Figure 11, and Table 19 and Figure 10, respectively. In both cases, the Atlantic Ocean (unspecified; i.e. the open Atlantic rather than an Atlantic coastal port) was the source of the great majority of ballast water entering the Seaway and the Great Lakes (418,508 MT; 72.6%).

DIS for all vessels have been combined (due to relatively small numbers) for each of the selected Great Lakes ports and recorded in Table 20. A total of 233,006 MT of ballast water from known sources was intended for discharge in the specified ports (39.4% of the total BOB that entered the Great Lakes). The ports of Duluth/Superior and Thunder Bay received the largest reported quantities; 42,934 MT and 80,301 MT respectively. Most of the ballast water received was from the Atlantic Ocean, but many ports still received some ballast water from other areas.

### **St. Lawrence River Ports**

A total of 328 vessels were recorded in the ECAREG database as having entered the ports of the St. Lawrence River between Quebec City and Montreal (Table 21; not including vessels that continued on to the Seaway). These ports have been combined for this study into a single unit, referred to as the Riverport. CONT comprised the largest group with 133 vessels, while 22 TANK vessels were the smallest group. The ballast condition was unknown for 18 vessels. Of the remaining 310 vessels, 82 (26.5%) carried acknowledged ballast (Table 22) and 222 (71.6%) carried unacknowledged ballast (Table 23).

Mean size of vessels that visited the Riverport was 18,333 GRT (Table 21), compared with 13,182 GRT (Table 1) for vessels that entered the St. Lawrence Seaway in transit to the Great Lakes. The largest vessels were bulkers, with a mean 15,353 GRT, while the smallest were tankers, with a mean 7,406 GRT.

DIS for vessels carrying acknowledged ballast was estimated at 581,954 MT (Table 26), while DIS for vessels carrying unacknowledged ballast was estimated at

519,924 MT (Table 27), for a total of 1,101,878 MT of ballast water discharged in the Riverport in 1991 (52.8% acknowledged, 47.2% unacknowledged). Most of the DIS was from bulk carriers that discharged an estimated 407,394 MT of acknowledged ballast and 91,443 MT of unacknowledged ballast, for a combined 498,837 MT (45.3% of the total). Container carriers, although they represented 40.5% of the vessel traffic, discharged an estimated 40,299 MT of ballast water, only 3.7% of the total.

As was seen in the Great Lakes ports (above), most vessels (66.7%) traveling to the Riverport (Figure 12) originated in Northeast Atlantic ports, with the Mediterranean Sea being the second greatest source of vessels (17.9%). Insufficient information was available to analyze the sources of ballast water carried by these vessels.

## **East Coast Ports**

### **Halifax**

A total of 953 vessels was recorded in the ECAREG database bound for Halifax (Table 28). Ballast condition was unknown for 21 vessels of the remaining 932 vessels, 136 (14.6%) arrived carrying acknowledged ballast and 796 (85.4%) arrived carrying unacknowledged ballast. CONT comprised the largest group at 519 vessels, while 89 TANK vessels were the smallest group. Mean size of vessels that visited Halifax was 25,931 GRT. Tankers were the largest vessels at a mean 41,587 GRT, and the smallest were general cargo carriers with a mean 9,042 GRT.

A total DIS of 2,815,660 MT was estimated for Halifax in 1991, 1,237,192 MT (43.9%; Table 29) acknowledged and 1,578,468 MT (56.1%; Table 30) unacknowledged. Bulk carriers discharged the greatest quantity at 1,085,276 MT (38.5%), while general cargo carriers discharged the smallest quantity at 94,300 MT (3.3%).

The greatest number of vessels bound for Halifax were from Northeast Atlantic ports (46.7%), while Northwest Atlantic ports were the second greatest source of vessels (27.9%; Figure 13).

### **St. John**

A total of 338 vessels were recorded in the ECAREG database bound for St. John

(Table 31). Ballast condition was unknown for 14 vessels. Of the remaining 324 vessels, 145 (44.8%) carried acknowledged ballast and 179 (55.2%) carried unacknowledged ballast. Bulk carriers were the largest group at 111 vessels, while container carriers were the rarest with 19 vessels. Mean size of vessels that visited Halifax was 20,269 GRT, the largest being tankers with a mean 40,756 GRT, while the smallest were general cargo carriers with a mean 9,265 GRT.

A total DIS of 1,542,505 MT was estimated for St. John in 1991, 1,002,820 MT acknowledged (65.0%; Table 32) and 539,685 MT unacknowledged (35.0%; Table 33). Bulk carriers discharged the greatest quantity at 790,170 MT (51.2%) while container carriers discharged the smallest quantity at 5,757 MT (0.4%).

The greatest number of vessels bound for St. John were from West Central Atlantic ports (42.9%), while Northeast Atlantic ports were the second greatest source of vessels (28.6%) (Figure 14).

### St. John's

A total of 86 vessels were recorded in the ECAREG database bound for St. John's in 1991 (Table 34). Ballast condition was unknown for 5 vessels. Of the remaining 81 vessels, 25 (30.9%) carried acknowledged ballast and 56 (69.1%) carried unacknowledged ballast. General cargo carriers were the largest group at 32 vessels while bulk carriers were the rarest at 1 vessel. Mean size of vessels that visited St. John's was 5,198 GRT. The largest vessels were bulk carriers, with a mean 17,818 GRT, and the smallest were tankers with a mean 2,034 GRT.

A DIS of 87,903 MT was estimated for St. John's in 1991, 39,575 MT (45.0%; Table 35) acknowledged and 48,328 MT unacknowledged (55.0%; Table 36). Tankers discharged the greatest quantity at 16,818 MT (19.1%), while the bulk carriers discharged the smallest quantity at 2,548 MT (2.9%).

The greatest number of vessels bound for St. John's were from Northwest Atlantic ports (78.7%), followed by Northeast Atlantic ports (14.7%; Figure 15).

## **West Coast Ports**

### Vancouver

A total of 3,117 vessels were recorded in the Vancouver Port Corporation records for

1991 (Table 37). With an estimated 90% of vessels arriving in ballast (see Methods), 2,805 of the 3,117 vessels would have arrived with acknowledged ballast while 312 would have arrived with unacknowledged ballast.

The mean size of all vessels that visited Vancouver was 22,216 GRT. A total DIS of 34,544,397 MT of ballast water was estimated for Vancouver in 1991, 33,775,005 MT (97.8%) acknowledged and 769,392 MT unacknowledged (2.2%; Table 37).

The greatest number of vessels bound for Vancouver were from Northwest Pacific ports (79.6%), with West Central Pacific ports being the second greatest source of vessels (7.6%; Figure 16).

#### Prince Rupert

A total of 398 vessels were recorded in the Prince Rupert Port Corporation records for 1991 (Table 38). With an estimated 90% of vessels arriving in ballast (see Methods), 358 of the 398 vessels would have carried acknowledged ballast while 40 would have arrived unacknowledged ballast.

The mean size of all vessels that visited Prince Rupert was 27,969 GRT. A total DIS of 5,551,122 MT of ballast water was estimated for Vancouver in 1991, 5,426,922 MT (97.8%) acknowledged and 124,200 MT unacknowledged (2.2%; Table 38).

The greatest number of vessels bound for Vancouver were from Northwest Pacific ports (68.3%), with Northeast Pacific ports being the second greatest source of vessels (23.6%; Figure 17).

#### **Comparison of Ballast Water Quantities Discharged**

Total DIS for the Great Lakes, Riverport and each of the selected coastal ports are presented in Table 39. Vancouver received the largest estimated quantity of ballast water at 34,544,397 MT, while St. John's received the smallest quantity at 87,903 MT. Quantities of acknowledged and unacknowledged ballast discharged are presented in Figure 18, and shown on a log scale in Figure 19.

#### **Comparison of Ballast Water Quantities Carried into Ports/Destinations**

The quantities of acknowledged and unacknowledged ballast water carried into - as opposed to discharged in - the different ports/destinations are recorded in Table 40. Again, the largest amount of ballast water was carried into Vancouver (virtually all

acknowledged), and the smallest into St. John's. Halifax and St. John's were the only ports to receive more unacknowledged than acknowledged ballast water.

The total estimated quantities of ballast water carried into the Great Lakes and the combined Canadian coastal ports are combined in Tables 41 and 42 for comparison and addition to the figures recorded in Shipping Study I (see Carlton et al., 1995).

## DISCUSSION

The quantity of ballast water discharged in any given port is a function of the number of vessels that arrive in that port, the size of those vessels, the type of vessels and the cargo transactions conducted in that port (whether the port is primarily a cargo loading or unloading port). A discussion of the relationship between ballast operations and cargo carried can be found in Shipping Study I.

### Great Lakes

In many ways, it is more useful to consider the Great Lakes as a single large port system (i.e., Riverport representing the upper St. Lawrence River between Quebec City and Montreal below) rather than as an assemblage of separate ports. This is indicated by the knowledge that foreign traffic often visits several U.S. and/or Canadian Great lakes ports (see Tables 13 and 14) on any given voyage. St. Lawrence Seaway Authority cargo records show that these vessels take on and/or discharge cargo during these port visits, and from our knowledge of cargo handling and ballasting operations (see Shipping Study I), these vessels probably discharge and/or take on some quantity of ballast water in most ports where cargo is handled.

Some evidence of this was seen by comparing St. Lawrence Seaway Authority data from vessels entering the Seaway and Bureau of Census data from vessels entering U.S. Great Lakes ports (see Table 17). The additional vessels entering Duluth/Superior in ballast show that a number of vessels entered the Seaway carrying some or full of cargo, discharged that cargo at a number of ports, probably taking on ballast water from at least some of those ports, and then discharged their ballast water (from foreign and/or other Great Lakes ports) in Duluth/Superior while loading their outbound cargo. It should be noted that these figures include several vessels that entered the Seaway in ballast, and subsequently picked up some cargo at various ports, at any or all of which they may have discharged some

of their ballast water, before completing their cargo loading at Duluth/Superior.

Large amounts of ballast water are also moved into and between ports within the Great Lakes by lakers (large cargo vessels that travel exclusively in the Great Lakes, and smaller ones that can transit the St. Lawrence Seaway locks). It has been estimated (Locke et al., 1991 ) that in 1990 these latter vessels carried approximately 1,800,000 MT of ballast water into the Great Lakes from the lower St. Lawrence River (below and including Montreal) and Gulf of St. Lawrence. Lakers are typically bulk carriers that repeatedly travel in full cargo on one leg of a journey and in full ballast on the next (G. Ryan, pers. comm.). It is readily apparent that once a nonindigenous species has been introduced into the Great Lakes, there would be ample opportunity for many vessels to secondarily spread the organisms to other areas of the Great Lakes, and for the Great Lakes to become an exporter of species proven to be capable invaders. The former instance is currently a concern with respect to transport of the ruffe *Gymnocephalus cernuus* in the Great Lakes (Tom Busiahn, pers. comm.), originally introduced in Duluth.

The current estimate of 1,395,461 MT of ballast water destined for discharge in the Great Lakes in 1991 (combining Tables 13 and 14) is almost twice as much as the 1990 estimate by Locke et al. (1991), that 719,473 MT of ballast water were carried into the Great Lakes by foreign traffic vessels. The amount of ballast water actually intended for discharge in the Great Lakes in 1990 was probably slightly less than the latter figure. In 1991, the quantity of acknowledged ballast water intended for discharge was 94.7% of the quantity carried (Table 11), while vessels carrying unacknowledged ballast intended to discharge 92.2% of their ballast water. If the 1990 vessels discharged as much as 95% of their ballast water, or 683,499 MT, this would only represent 49.0% of the quantity reported as intended for discharge in 1991.

The quantity of ballast water carried into the Great Lakes by foreign commercial vessels does vary widely from year-to-year. Ballast Water Exchange Reports (BWERs) collected by the St. Lawrence Seaway in 1990 report that 190 vessels carried an average 1,822 MT of ballast water into the Great Lakes. The 455 vessels identified by Locke et al. in 1990 as entering the Seaway in 1990 would therefore have carried an estimated 829,010 MT of ballast water (Note: these are arithmetical calculations, not estimates based on conversion factors as used in this study above,

nor do they allow for relative numbers of vessels traveling under different ballast conditions as did Locke et al. (1991) and the present study). Similarly, the BWERs collected from 202 vessels in 1991 reported an average of 2,986 MT per vessel carried into the Great Lakes; the 427 vessels identified as entering the Seaway in 1991 in the present study would therefore have carried 1,275,022 MT of ballast water. The same calculations for 1992 (191 BWERs reporting an average of 1,059 MT carried), with 427 foreign vessel upbound transits in the Seaway (Joe Craig, personal communication), indicate that only 452,193 MT of ballast water was carried into the Seaway in 1992. The figures determined by both Locke et al. (1991) and the current study (previous paragraph) are therefore considered to be not unreasonable estimates.

The 427 vessels that entered the Seaway in 1991 intended to discharge an average of 3,268 MT of ballast water (acknowledged and unacknowledged combined). It was felt that this was a more accurate estimate than the arithmetic mean of 4,287 MT from Table 4. Locke et al. (1991) reported that 455 foreign traffic vessels carried 719,473 MT of ballast water into the Great Lakes in 1990, an average of 1,581 MT.

The number of in ballast vessels (143) entering the Seaway in 1991 was derived from St. Lawrence Seaway Authority records documenting vessels traveling upbound with no cargo. The distinction between with ballast and no ballast vessels in the Locke et al (1991) study was largely based on Vessel Traffic Services reports made by the ship's officers to the Canadian Coast Guard. They estimated that 219 of 455 vessels entered the St. Lawrence Seaway "in" or "with" ballast water in 1990 (in ballast or with some quantity of ballast water ballast water), carrying an average of 3,115 MT of ballast water on board (BOB). They also estimated that 236 of 455 vessels (51.9%) entered the Seaway in 1990 with no ballast water on board.

Canadian Coast Guard records for 1991 show that 78 vessels of 233 records reported NOBOB; extrapolating this 33.5% to 427 vessels results in an estimate of 143 NOBOB vessels in 1991, with the remaining 284 traveling in or with ballast. Substantially more vessels therefore carried ballast water into the Great Lakes in 1991 (284) than in 1990 (219). Using the 1990 BOB estimates of Locke et al. (1991) and recalculating, the 1991 NOBOB vessels in the current study would have carried an estimated 22,594 MT (143 x 158 MT), and the remaining vessels an estimated 884,660 MT (284 x 3,115 MT) for a total of 907,254 MT of ballast water in

1991. It is apparent that foreign traffic vessels were carrying considerably more ballast water into the Great Lakes in 1991 than in 1990.

Bulk carriers were responsible for most of the ballast water discharged in the Great Lakes in 1991 (88.2%: from Tables 15 and 16), with Hamilton receiving the largest quantity (144,873 MT). Duluth/Superior and Thunder Bay, Lake Superior's "Lakehead" bulk ports, received 144,873 MT and 98,353 MT respectively. While other vessel types discharged smaller quantities of ballast water in the Great Lakes, they typically carry mixed cargoes, are more likely to visit multiple ports, and therefore more likely to conduct ballast operations (discharge or take on) in several ports. Whether the chance of a nonindigenous species introduction is more likely where large volumes of water are discharged, or where multiple inoculations occur, is unknown.

The estimates of ballast water discharged in individual Great Lakes ports are conservative. Although the four U.S. and four Canadian ports represent the most active ports, many ports recording vessel visits in 1991 were necessarily omitted. The ballast water reported as intended for discharge in the eight selected Great Lakes ports represented only 58.5% of the ballast water expected to be discharged in the Great Lakes as a whole (calculated from Tables 13 and 14). Furthermore, only 41.5% of the ballast reportedly carried by vessels entering the Seaway had any indication of where it was intended to be discharged; undoubtedly much of the remaining ballast water was also discharged in the Great Lakes. Since only 47.3% of vessels filed a BWER, our information on ballast carried and discharged is based on less than half of the vessels that entered the Seaway in 1991.

Since in ballast vessels normally visited few ports (1.0 - 1.5 port visits per vessel; Table 13), adjusting for multiple port visits had relatively little effect on the estimated quantity of ballast water intended for discharge in a given port. It was estimated that 63.2% of the ballast water discharged in the Great Lakes by in ballast vessels was discharged in the eight selected ports.

Vessels carrying unacknowledged ballast discharged approximately half as much ballast water (from Tables 13 and 14) into the Great Lakes as vessels carrying acknowledged ballast, even though they were twice as numerous. Only 48.7% of the ballast water discharged by vessels carrying unacknowledged ballast was intended

for discharge in the eight selected ports. While adjusting for multiple port visits (2.3 - 4.2 per vessel; Table 14) may have resulted in some underestimation of the quantity of unacknowledged ballast water discharged in the eight selected ports, it is felt that this is limited since those multiple visits include the other selected ports. Any underestimation serves to maintain these figures as conservative estimates.

### **Last Port of Call by FAO Region**

With the exception of Windsor (which received very few vessels), the major source of foreign traffic vessels for the Great Lakes and the individual Great Lakes ports was Northeast Atlantic ports, i.e., northern Europe (Figures 1-9), while slightly less than 75% of the ballast water carried into the Great Lakes was reportedly from the open Atlantic Ocean. This is a result of the voluntary Great Lakes Ballast Water Control Guidelines (GLBWCG), initiated by the Canadian Coast Guard in 1989. Essentially, vessels bound for the Great Lakes and carrying ballast water from ports or coastal areas of less than 2,000 meters depth, were requested to exchange that ballast water in transit in oceanic waters where water depth was greater than 2,000 m prior to their entry into the St. Lawrence Seaway.

Compliance to the GLBWCG was monitored with the Ballast Water Exchange Reports (BWERs) mentioned above. Not all vessels exchanged their ballast water as requested, and some ballast water from foreign ports was recorded on the BWERs. Although many other vessels reportedly exchanged ballast water according to the guidelines, level of exchange was not recorded and therefore the amount of non-oceanic water still actually entering the Great Lakes is unknown.

### **Riverport**

The major difference seen in foreign vessel traffic between the Great Lakes and the Riverport is that the largest single vessel category in the latter is composed of container carriers, a vessel type that was not reported in the Great Lakes in 1991. As discussed in Shipping Study I, ballast operations conducted by container carriers typically involve small volumes of ballast water, but are repeated in most port visits, resulting in small quantities of ballast water being taken on and/or discharged in most ports visited. Container carriers represented 133 of the 328 vessel arrivals (40.5%) in the Riverport in 1991 (Table 21).

Although it was estimated that container carriers discharged only 40,299 MT of

ballast water in the Riverport in 1991 (3.7% of the total 1,101,878 MT), they do represent a large number of inoculations. (It should also be noted that many of the vessels that did enter the St. Lawrence Seaway in transit to the Great Lakes would have made prior port visits in the Riverport as well.) As was seen in foreign vessel traffic bound for the Great Lakes, Northeast Atlantic ports (northern Europe) supply most of the vessels (66.7%) that enter the Riverport (Figure 12).

## **Coastal Ports**

### **Vancouver Port**

Corporation data were able to supply some support for the current estimated quantity of ballast water discharged in Vancouver. The Corporation has commenced recording ballast water information collected from incoming vessels. In the first two months of 1993, 170 vessels reported that they would discharge 1,870,547 MT of ballast water, and average of 11,003 MT per vessel. Extrapolating this to the 3,117 vessel arrivals recorded in 1991 results an estimate of 34,296,351 MT of ballast water discharged in Vancouver, very close to our calculated estimate of 34,544,397 MT. This suggests that our estimates are reasonable, even though based on conversion factors derived for Great Lakes and Riverport vessels and used in all of our coastal port estimates.

### **Total Discharged**

If the remaining Canadian coastal ports receive 1.0% of the ballast water received by the six major coastal ports (including the Riverport) selected here (derived from a similar extrapolation used in Shipping Study I, Table 4-15), we can estimate that 47,925,638 MT (45,643,465 MT x 1.05) of ballast water were discharged in 1991.

### **Total Carried**

If foreign commercial vessels carried 1.0% of the average quantity of ballast water received by the six major coastal ports (including the Riverport) selected here (derived from a similar extrapolation used in Shipping Study I, Table 4-15), into the remaining Canadian coastal ports, we can estimate that 47,925,638 MT (45,643,465 MT x 1.05) of ballast water were carried into Canadian coastal ports in 1991 (Table 42). Combining this estimate with the 1,395,461 MT estimated as carried into the Great Lakes (Table 41) with the 57,690,000 MT estimated for coastal U.S. ports in Shipping Study I results in a combined U.S.-Canadian estimate of 107,011,099 MT.

## LITERATURE CITED

- Bederman, D. J. 1991. International control of marine "pollution" by exotic species. *Ecology Law Quarterly* 18: 677-717.
- Carlton, James T., Donald M. Reid, and Henry van Leeuwen. 1995. Shipping Study. The role of shipping in the introduction of non-indigenous aquatic organisms to the coastal waters of the United States (other than the Great Lakes) and an analysis of control options. The National Sea Grant College Program/Connecticut Sea Grant Project R/ES-6. Department of Transportation, United States Coast Guard, Washington, D.C. and Groton, Connecticut. Report Number CO-D-11-95. Government Accession Number AD-A294809. 213 pages and Appendices A-1 (122 pages).
- Locke, Andrea, Donald M. Reid, W. Gary Sprules, James T. Carlton, and Henry C. van Leeuwen. 1991. Effectiveness of mid-ocean exchange in controlling freshwater and coastal zooplankton in ballast water. *Canadian Technical Report Fisheries and Aquatic Sciences* no. 1822, 93 pp.

# LAST PORT OF CALL BY FAO REGION

## FOR SHIPS FROM FOREIGN PORTS - GREAT LAKES

### DATA FROM ST. LAWRENCE SEAWAY AUTHORITY

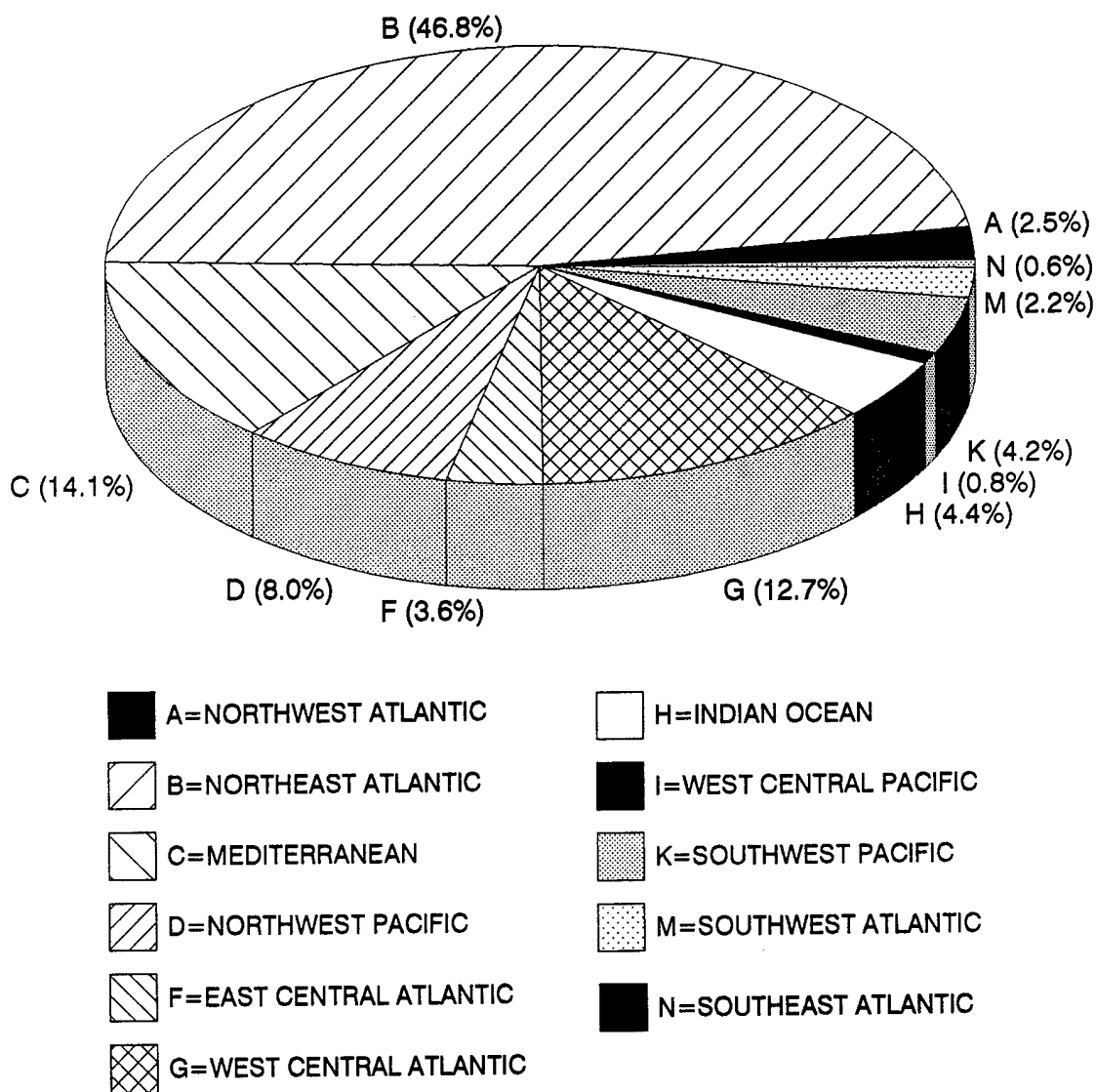

**FIGURE 1**

# LAST PORT OF CALL BY FAO REGION

FOR SHIPS FROM FOREIGN PORTS - DETROIT  
DATA FROM ST. LAWRENCE SEAWAY AUTHORITY

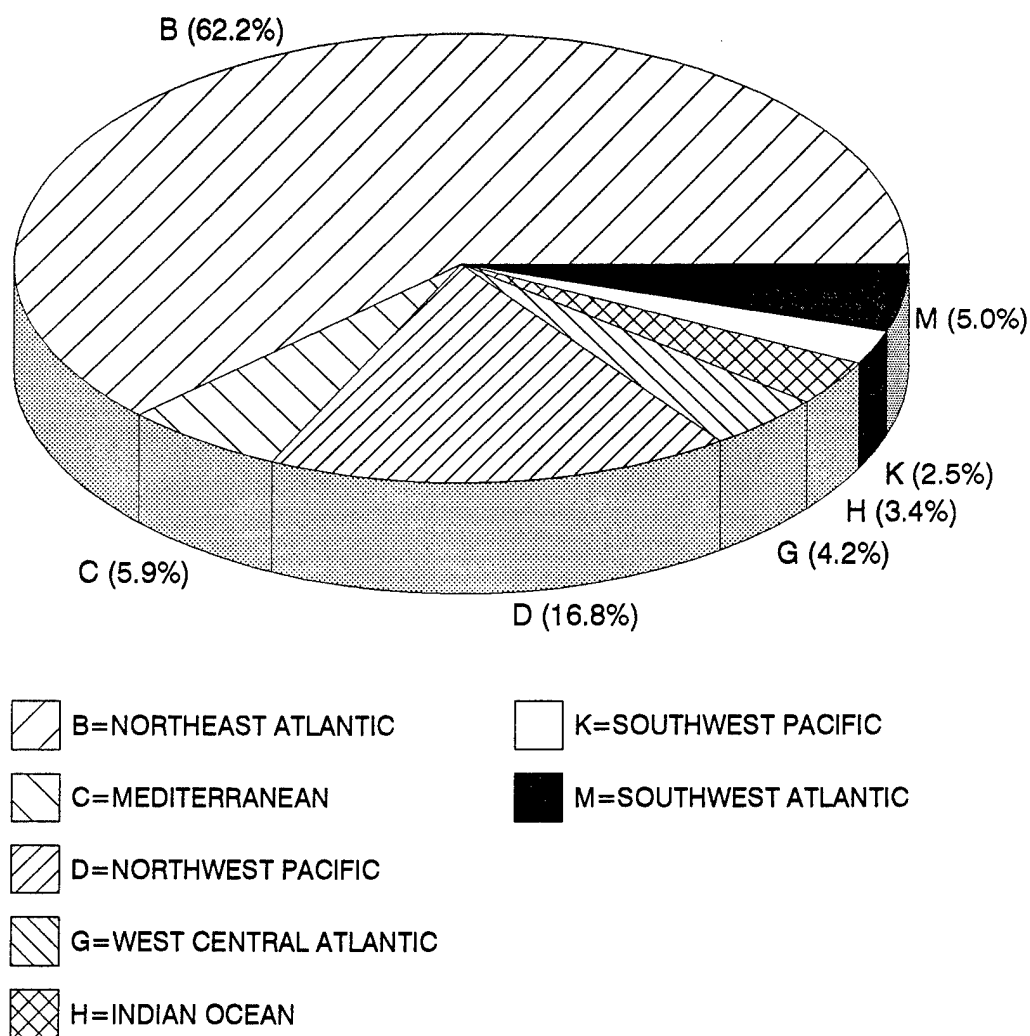
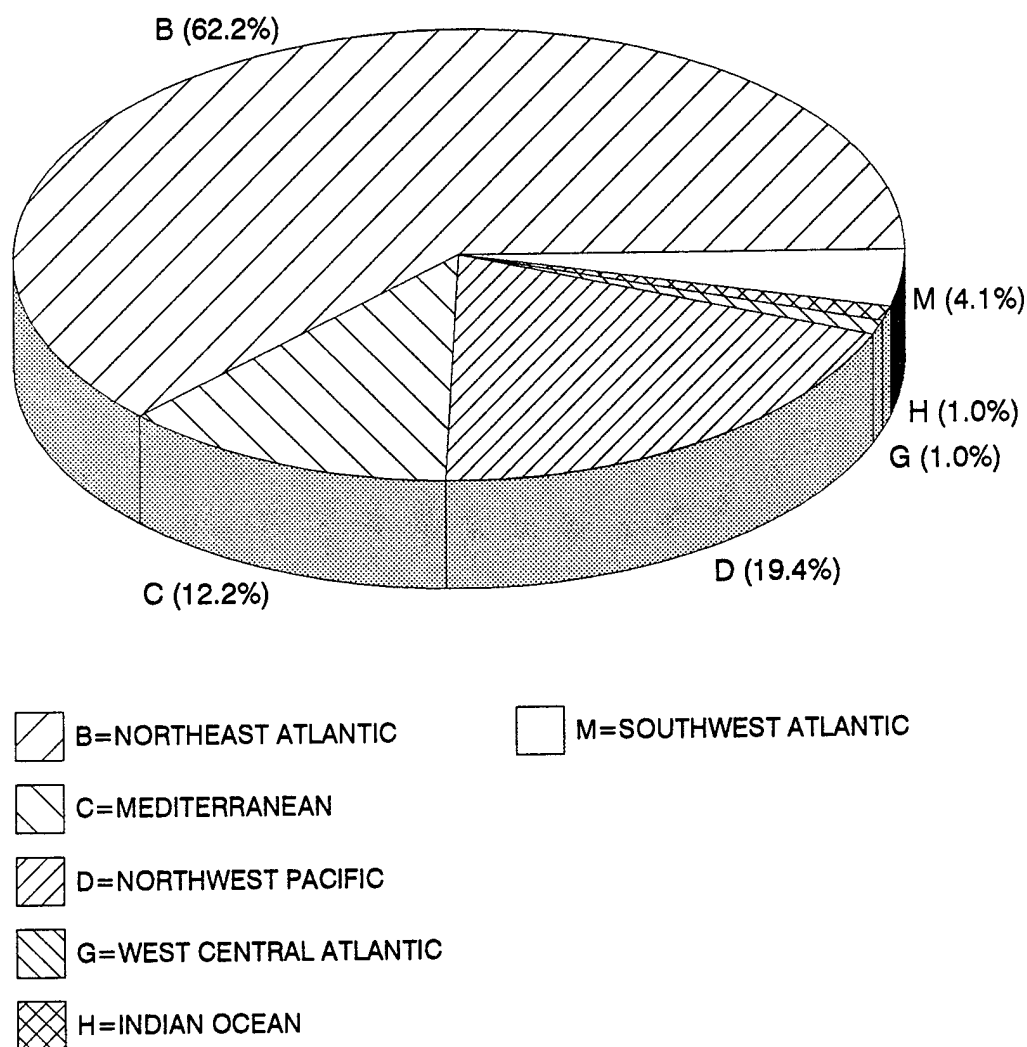

FIGURE 2

# LAST PORT OF CALL BY FAO REGION

FOR SHIPS FROM FOREIGN PORTS - CHICAGO  
DATA FROM ST. LAWRENCE SEAWAY AUTHORITY



**FIGURE 3**

# LAST PORT OF CALL BY FAO REGION FOR SHIPS FROM FOREIGN PORTS - CLEVELAND DATA FROM ST. LAWRENCE SEAWAY AUTHORITY

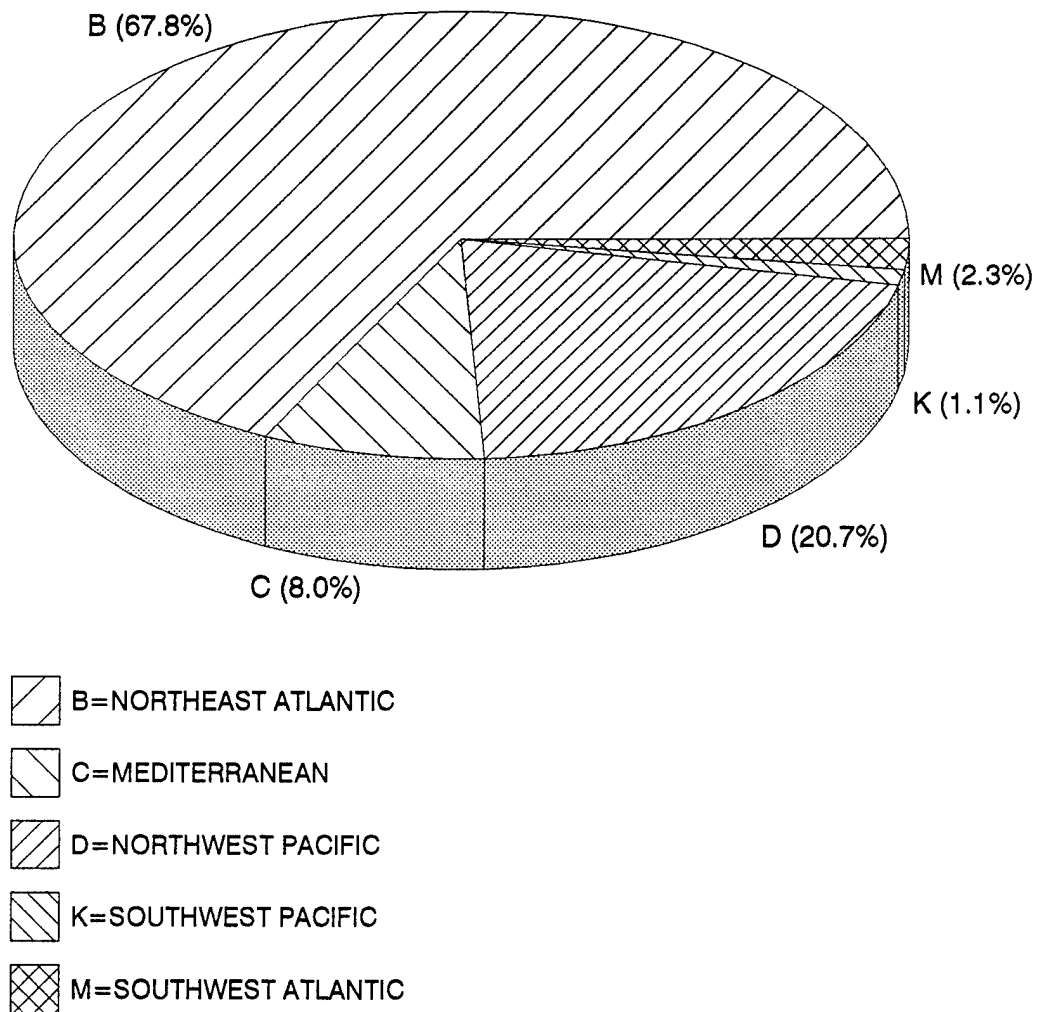
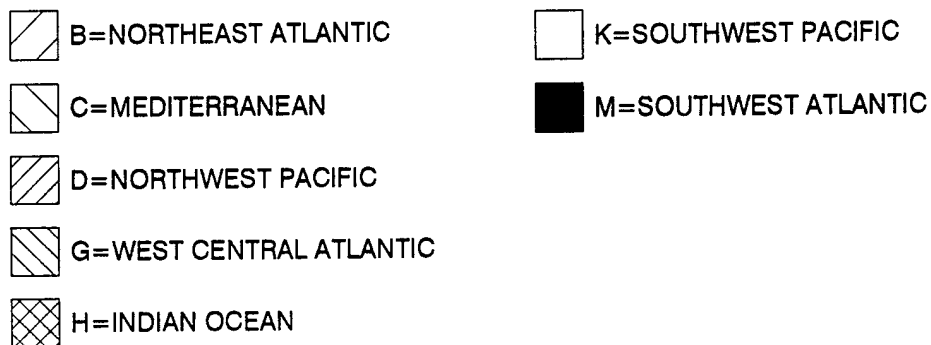
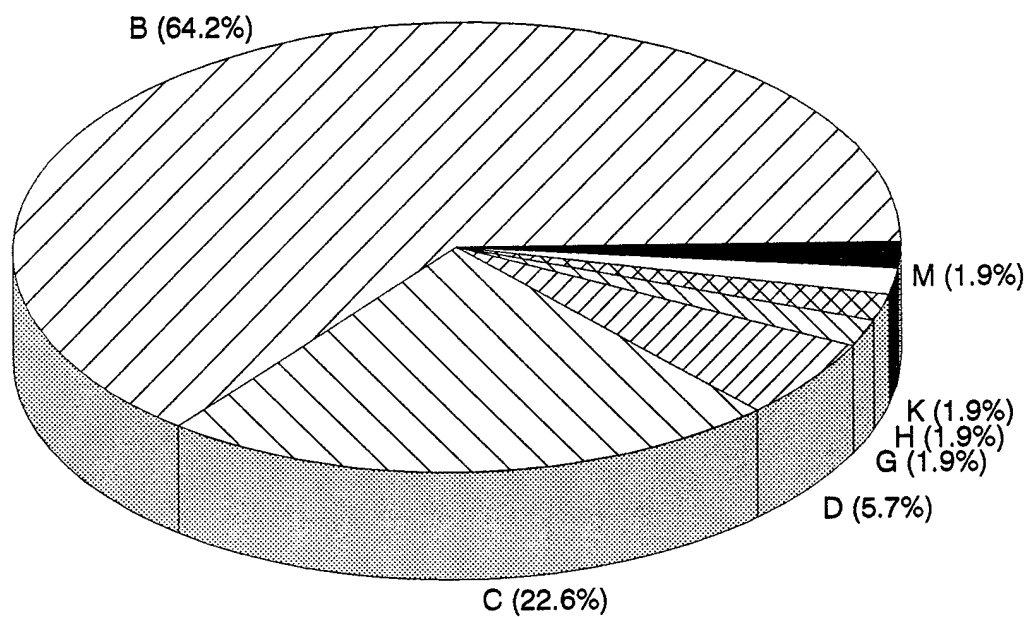

**FIGURE 4**

# LAST PORT OF CALL BY FAO REGION

## FOR SHIPS FROM FOREIGN PORTS - DULUTH/SUPERIOR

### DATA FROM ST. LAWRENCE SEAWAY AUTHORITY



**FIGURE 5**

# LAST PORT OF CALL BY FAO REGION

FOR SHIPS FROM FOREIGN PORTS - HAMILTON  
DATA FROM ST. LAWRENCE SEAWAY AUTHORITY

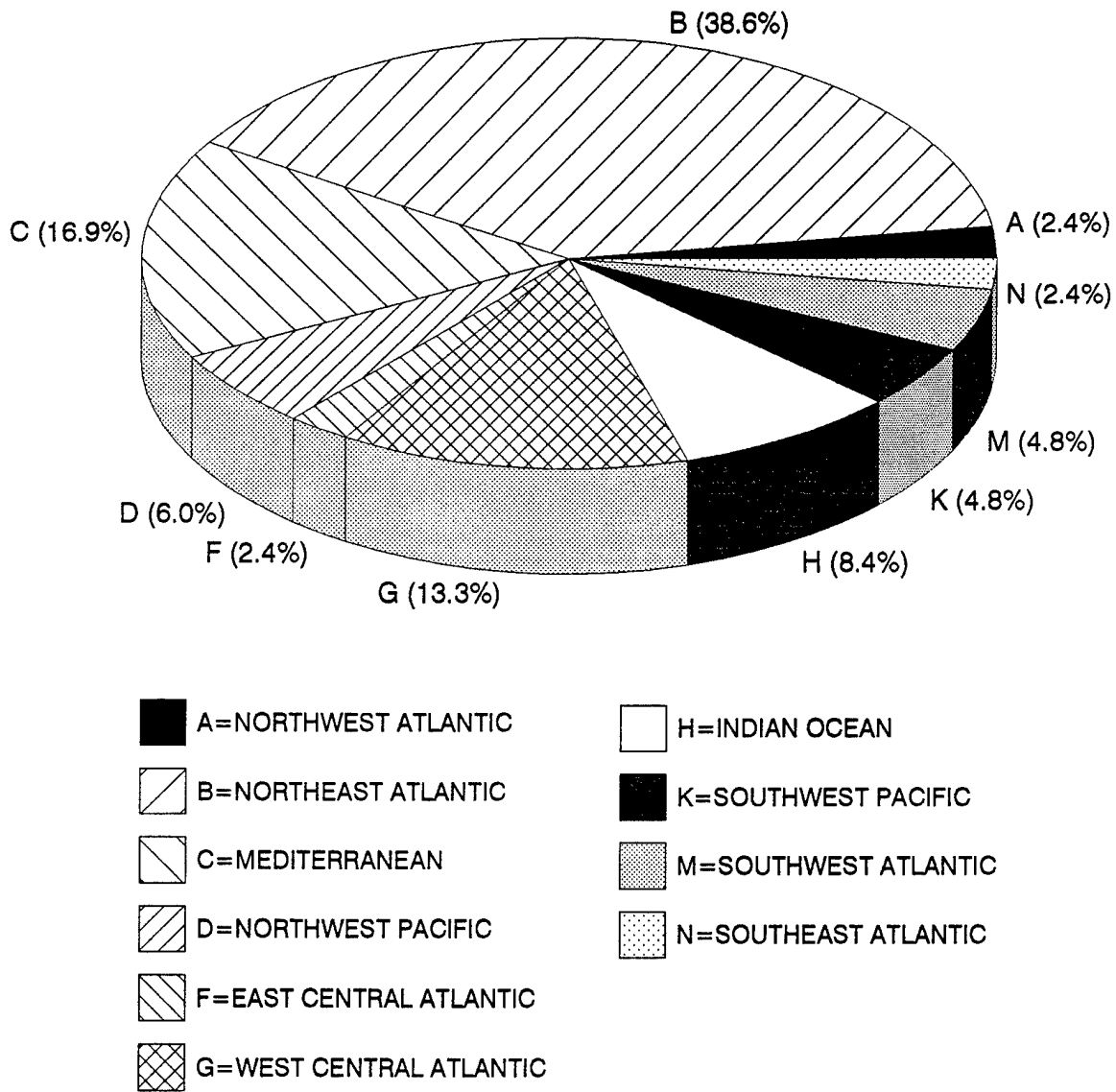
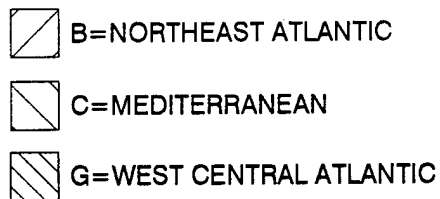
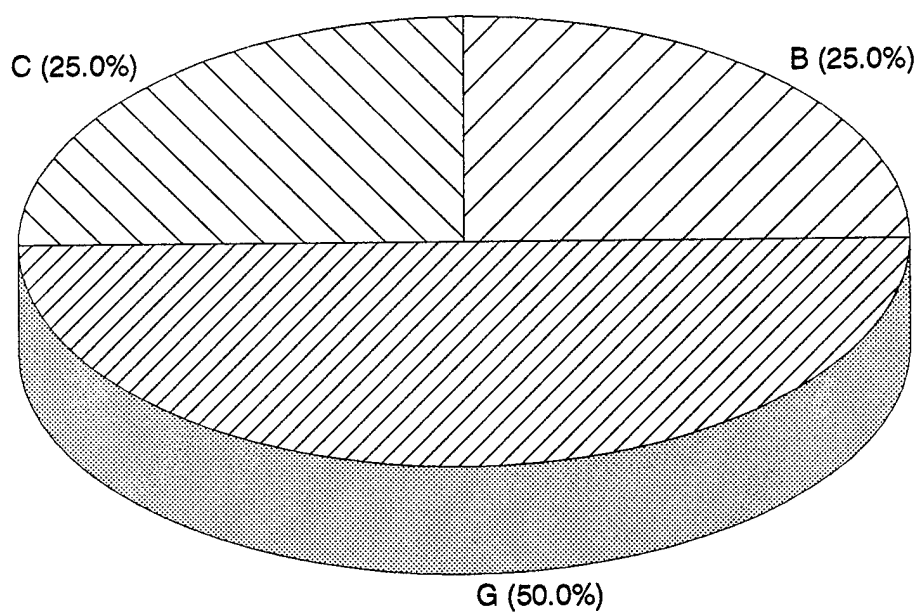

FIGURE 6

# LAST PORT OF CALL BY FAO REGION

FOR SHIPS FROM FOREIGN PORTS - WINDSOR  
DATA FROM ST. LAWRENCE SEAWAY AUTHORITY







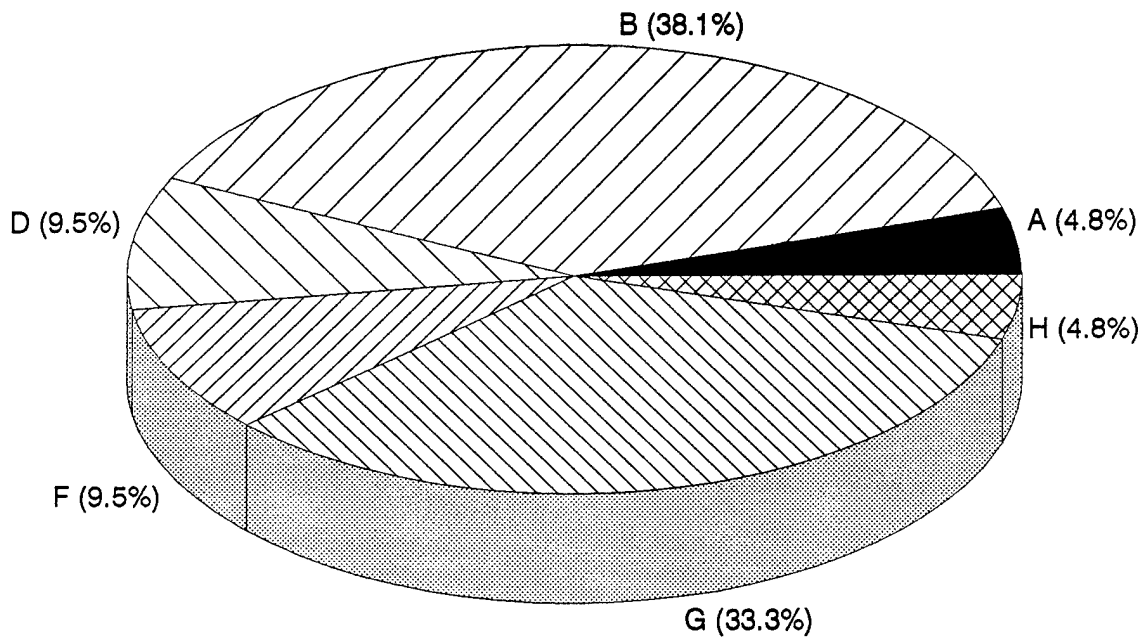

**FIGURE 7**

# LAST PORT OF CALL BY FAO REGION

FOR SHIPS FROM FOREIGN PORTS - SARNIA  
DATA FROM ST. LAWRENCE SEAWAY AUTHORITY



-  A=NORTHWEST ATLANTIC
-  B=NORTHEAST ATLANTIC
-  D=NORTHWEST PACIFIC
-  F=EAST CENTRAL ATLANTIC
-  G=WEST CENTRAL ATLANTIC
-  H=INDIAN OCEAN

**FIGURE 8**

# LAST PORT OF CALL BY FAO REGION FOR SHIPS FROM FOREIGN PORTS - THUNDER BAY DATA FROM ST. LAWRENCE SEAWAY AUTHORITY

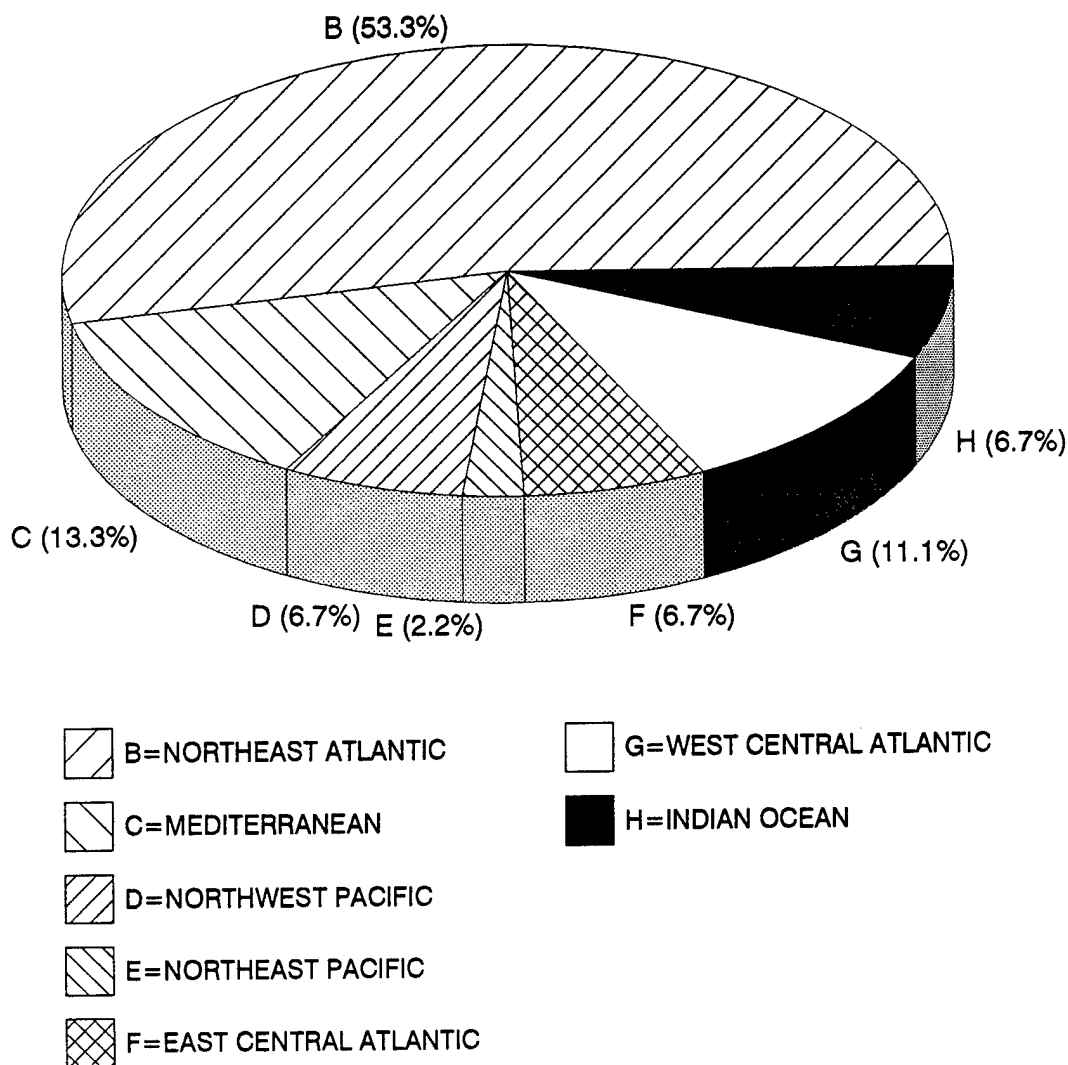

FIGURE 9

# BALLAST WATER SOURCE BY FAO REGION

UNACKNOWLEDGED BALLAST FROM FOREIGN PORTS - GREAT LAKES  
DATA FROM BALLAST WATER EXCHANGE REPORTS

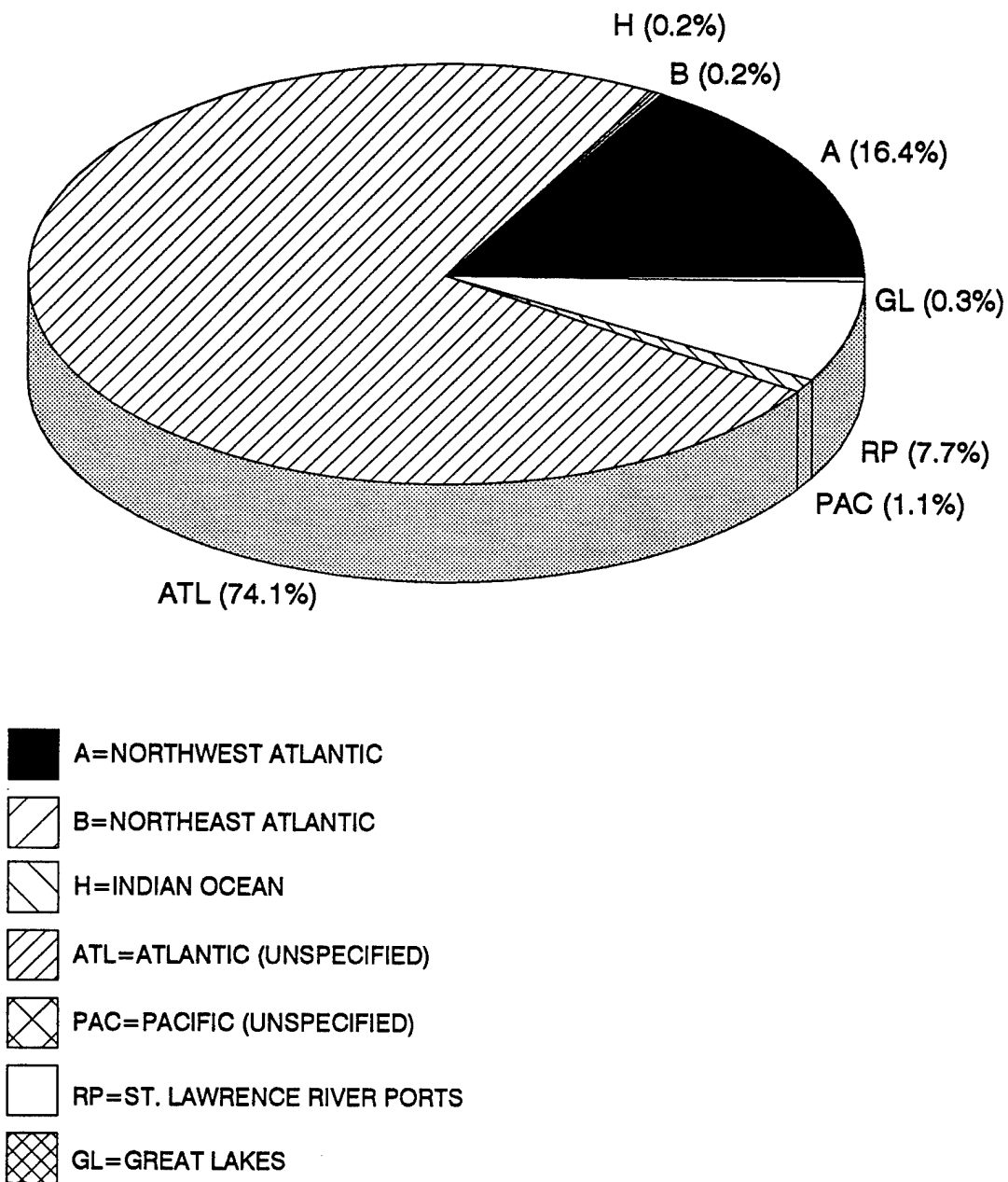
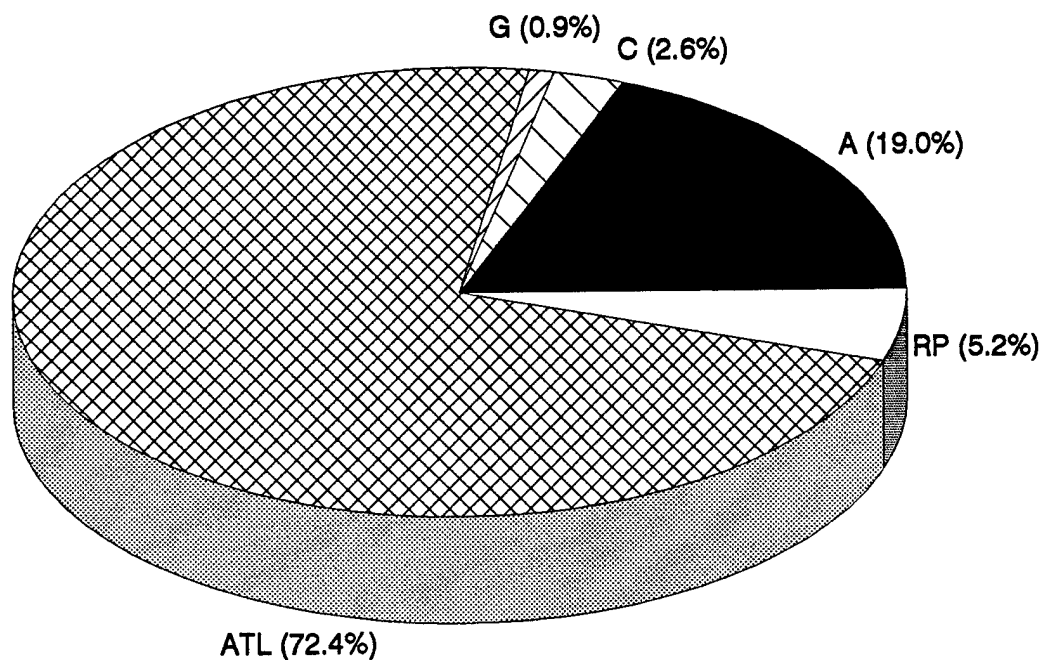

FIGURE 10

# BALLAST WATER SOURCE BY FAO REGION

ACKNOWLEDGED BALLAST FROM FOREIGN PORTS - GREAT LAKES  
DATA FROM BALLAST WATER EXCHANGE REPORTS







-  A=NORTHEAST ATLANTIC
-  C=MEDITERRANEAN
-  G=WEST CENTRAL ATLANTIC
-  ATL=ATLANTIC (UNSPECIFIED)
-  RP=ST. LAWRENCE RIVER PORTS

FIGURE 11

# LAST PORT OF CALL BY FAO REGION

## FOR SHIPS FROM FOREIGN PORTS - RIVERPORT

### DATA FROM ECAREG

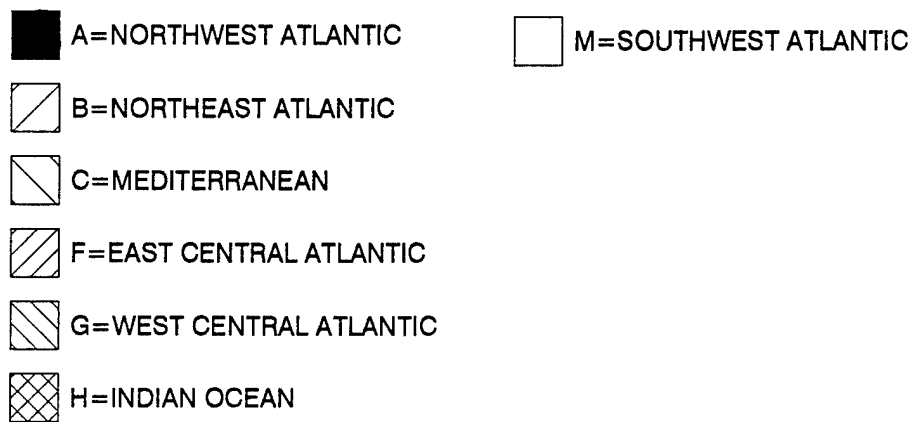
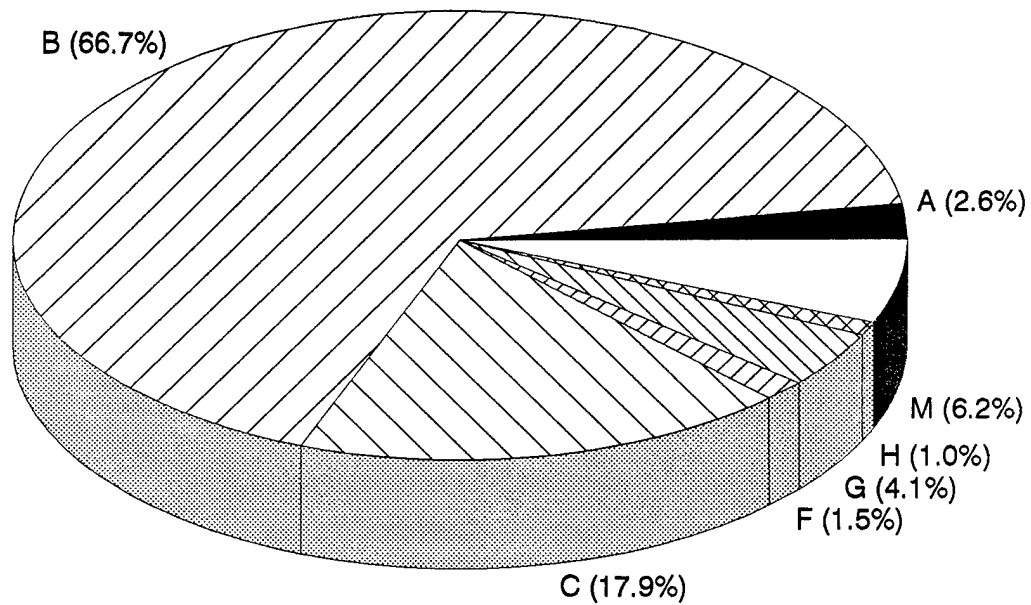

**FIGURE 12**

# LAST PORT OF CALL BY FAO REGION

FOR SHIPS FROM FOREIGN PORTS - HALIFAX

DATA FROM ECAREG

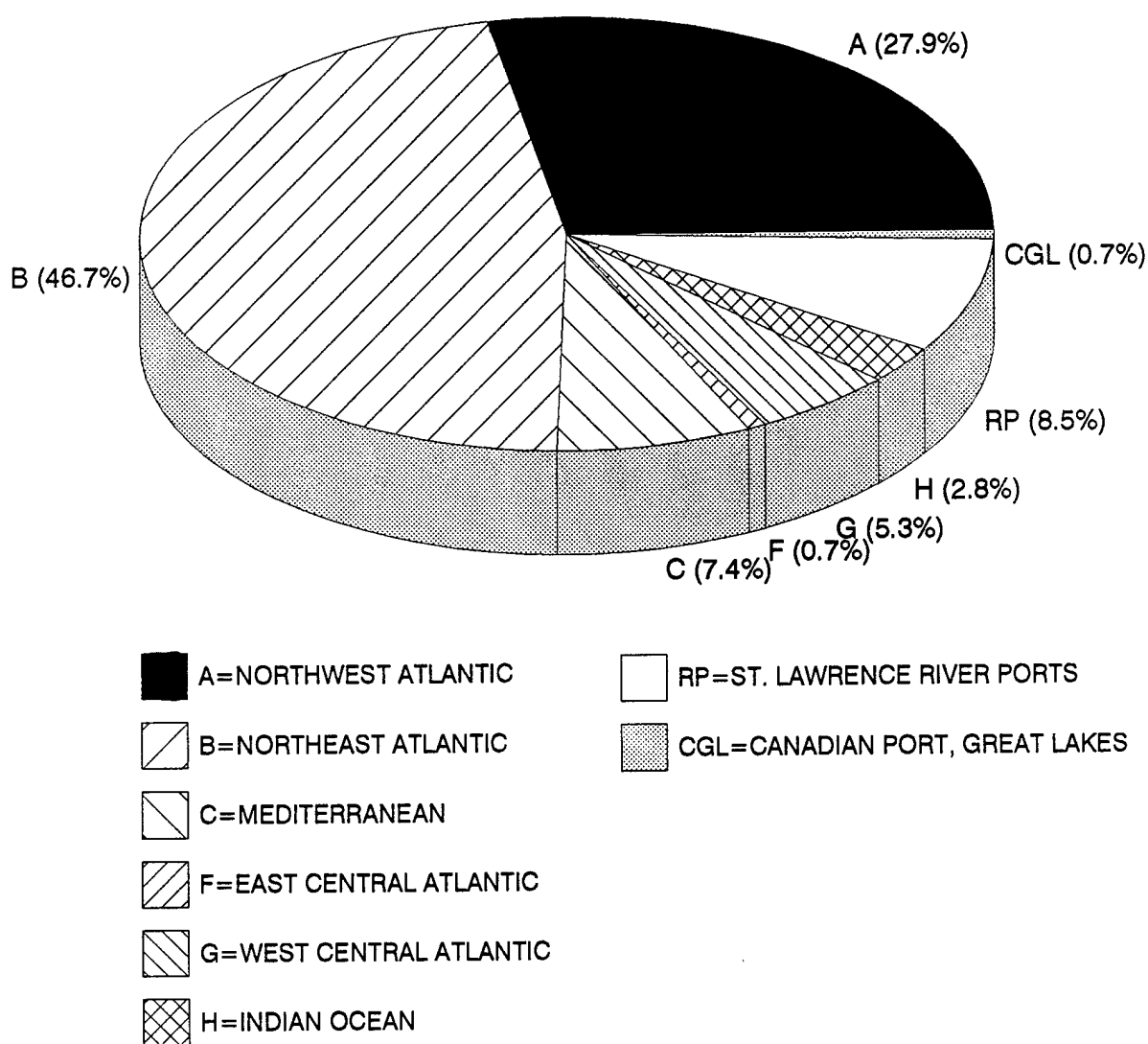

FIGURE 13

# LAST PORT OF CALL BY FAO REGION

FOR SHIPS FROM FOREIGN PORTS - ST. JOHN

DATA FROM ECAREG

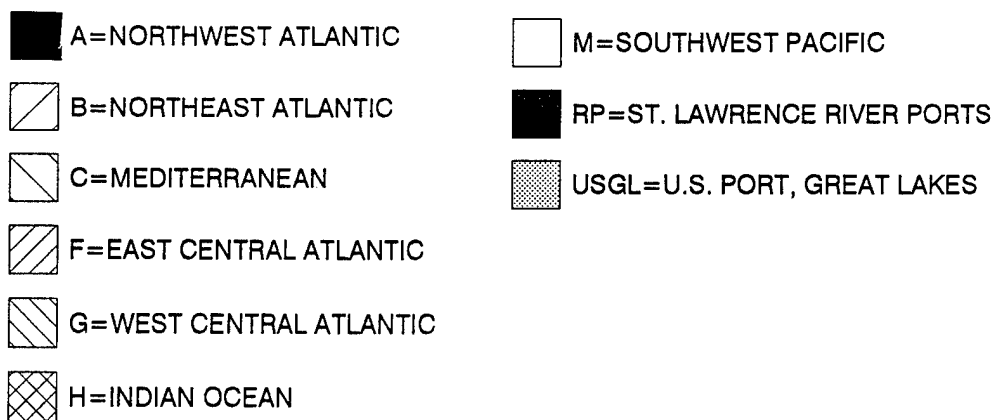
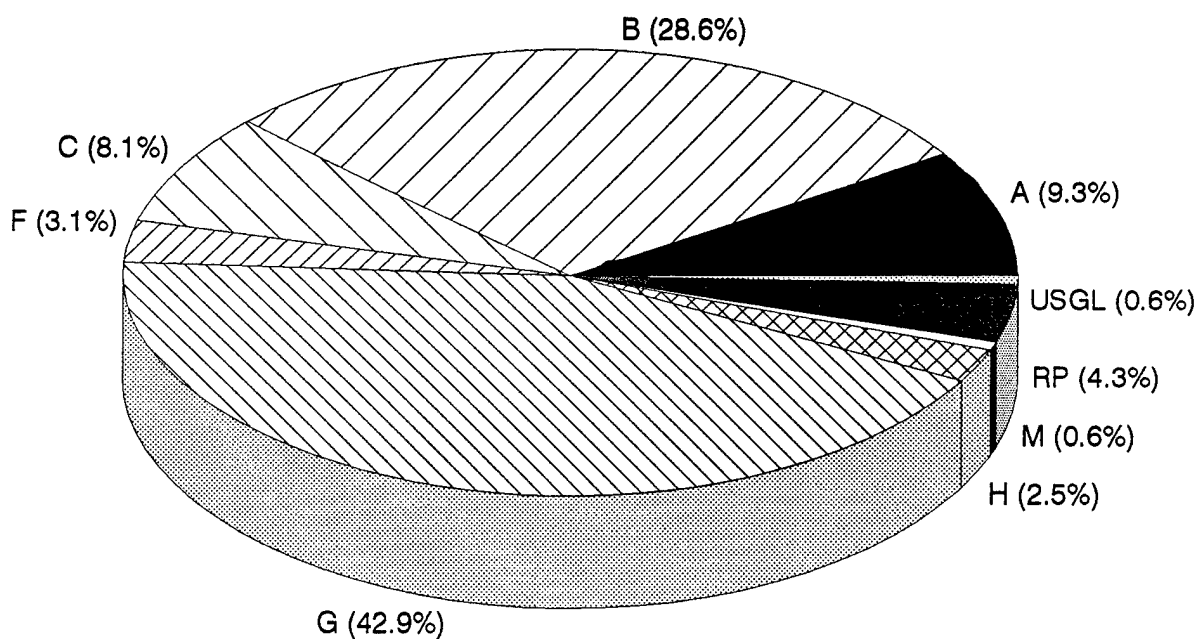
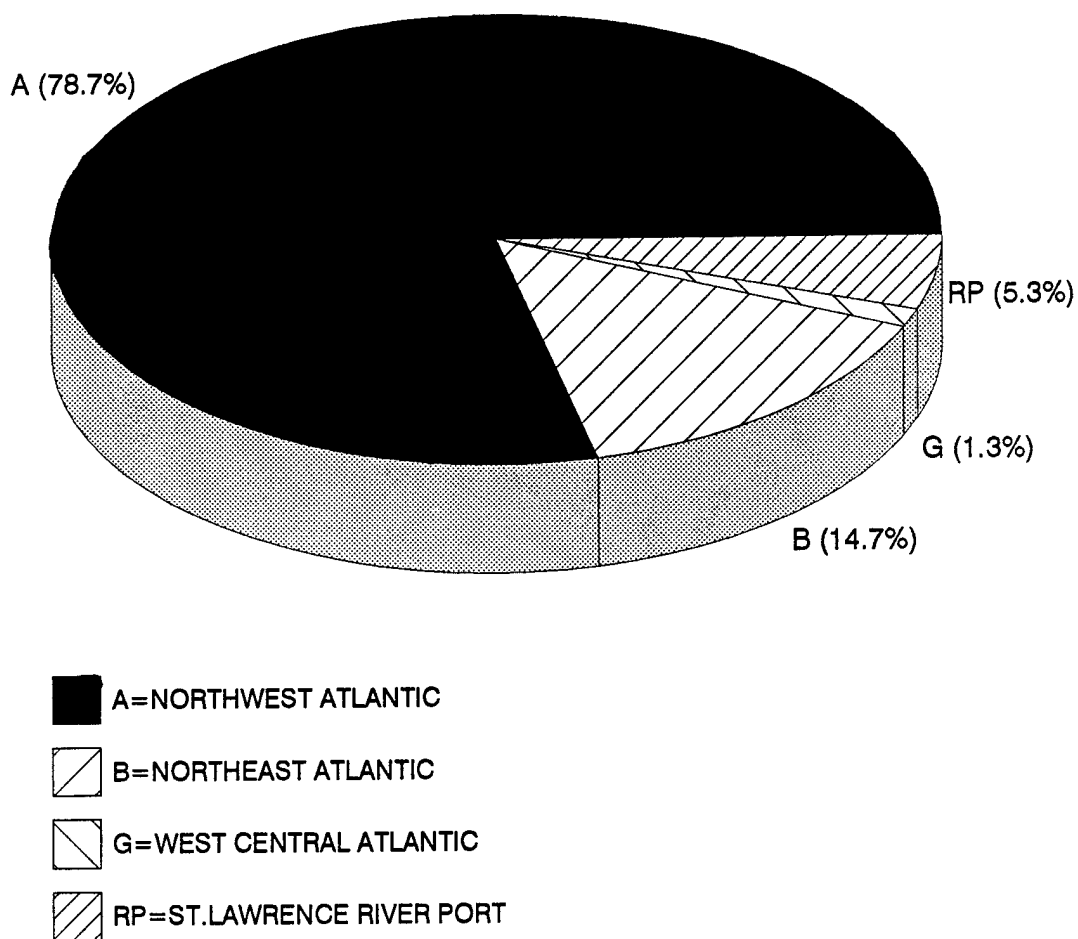

FIGURE 14

# LAST PORT OF CALL BY FAO REGION FOR SHIPS FROM FOREIGN PORTS - ST. JOHN'S DATA FROM ECAREG





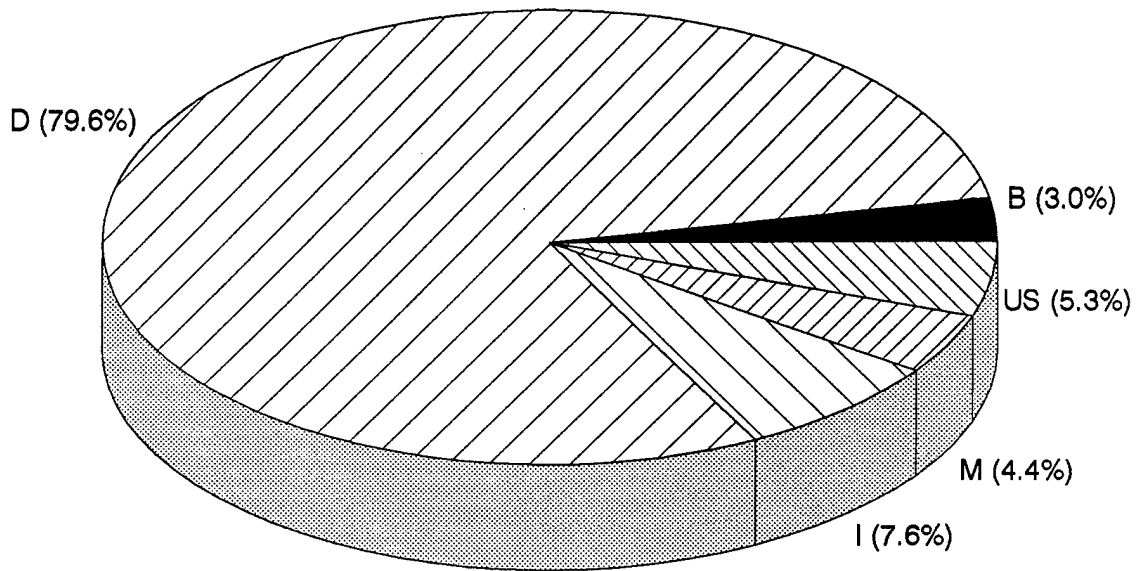

**FIGURE 15**

# LAST PORT OF CALL BY FAO REGION

FOR SHIPS FROM FOREIGN PORTS - VANCOUVER  
DATA FROM THE VANCOUVER PORT CORPORATION



-  B=NORTHEAST ATLANTIC
-  M=SOUTHWEST ATLANTIC
-  D=NORTHWEST PACIFIC
-  US=U.S PORT
-  I=WEST CENTRAL PACIFIC

**FIGURE 16**

# LAST PORT OF CALL BY FAO REGION

FOR SHIPS FROM FOREIGN PORTS - PRINCE RUPERT  
DATA FROM THE PRINCE RUPERT PORT CORPORATION

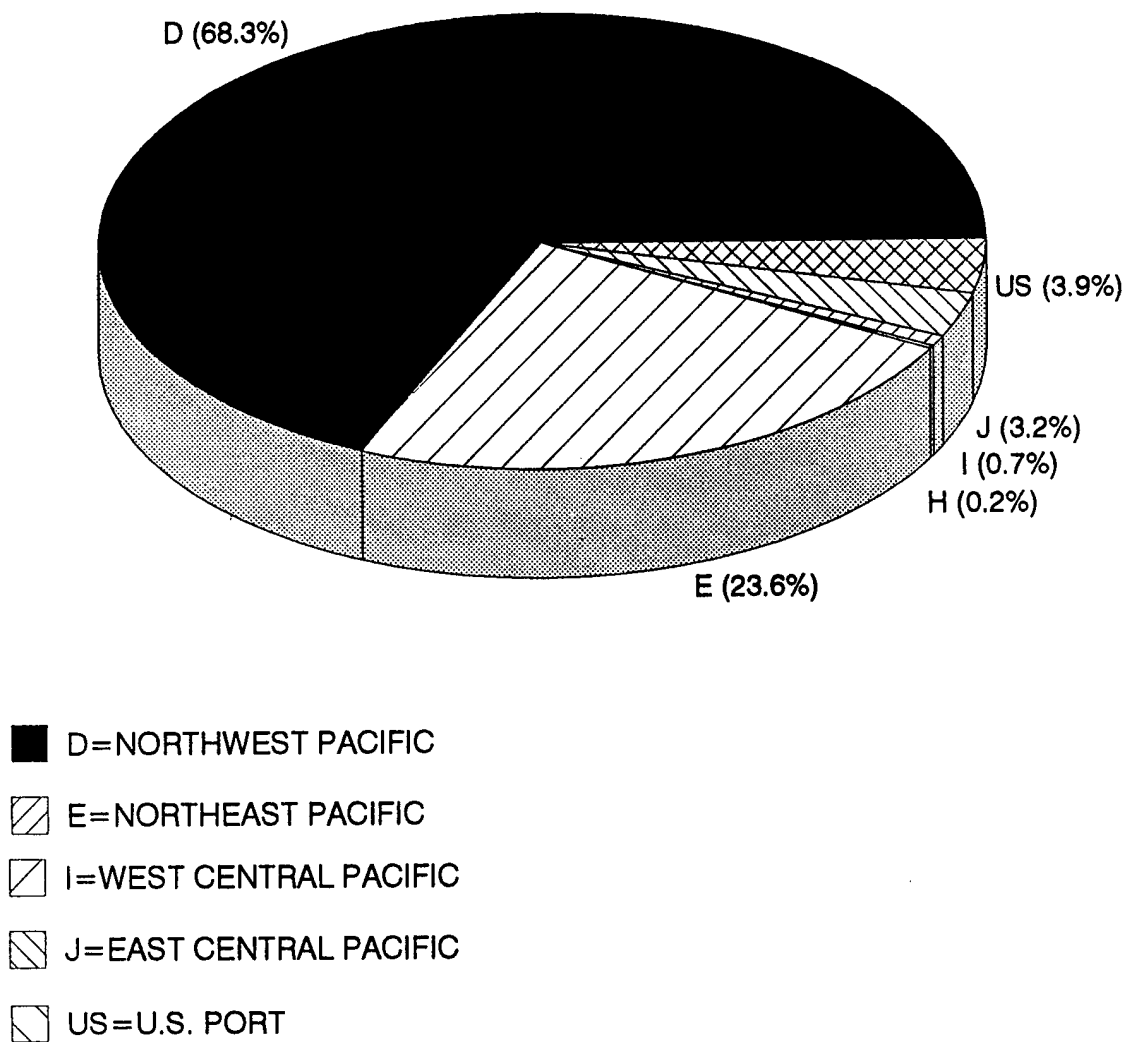

FIGURE 17

### Legend for Figures 18 and 19

The names of the ports and locations have been coded in the figures.

---

CODE	LOCATION	DESCRIPTION
GL	Great Lakes	The ports of the upper St. Lawrence River above the entrance to the Seaway at Montreal and the U.S. and Canadian ports of the Great Lakes
RP	Riverport	The ports of the St. Lawrence River between Quebec City and Montreal inclusive
HF	Halifax, NS	
SB	St. John, NB	
SF	St. John's, NF	
VA	Vancouver, BC	
PR	Prince Rupert, BC	

---

# BALLAST WATER DISCHARGED IN THE GREAT LAKES AND SELECTED PORTS

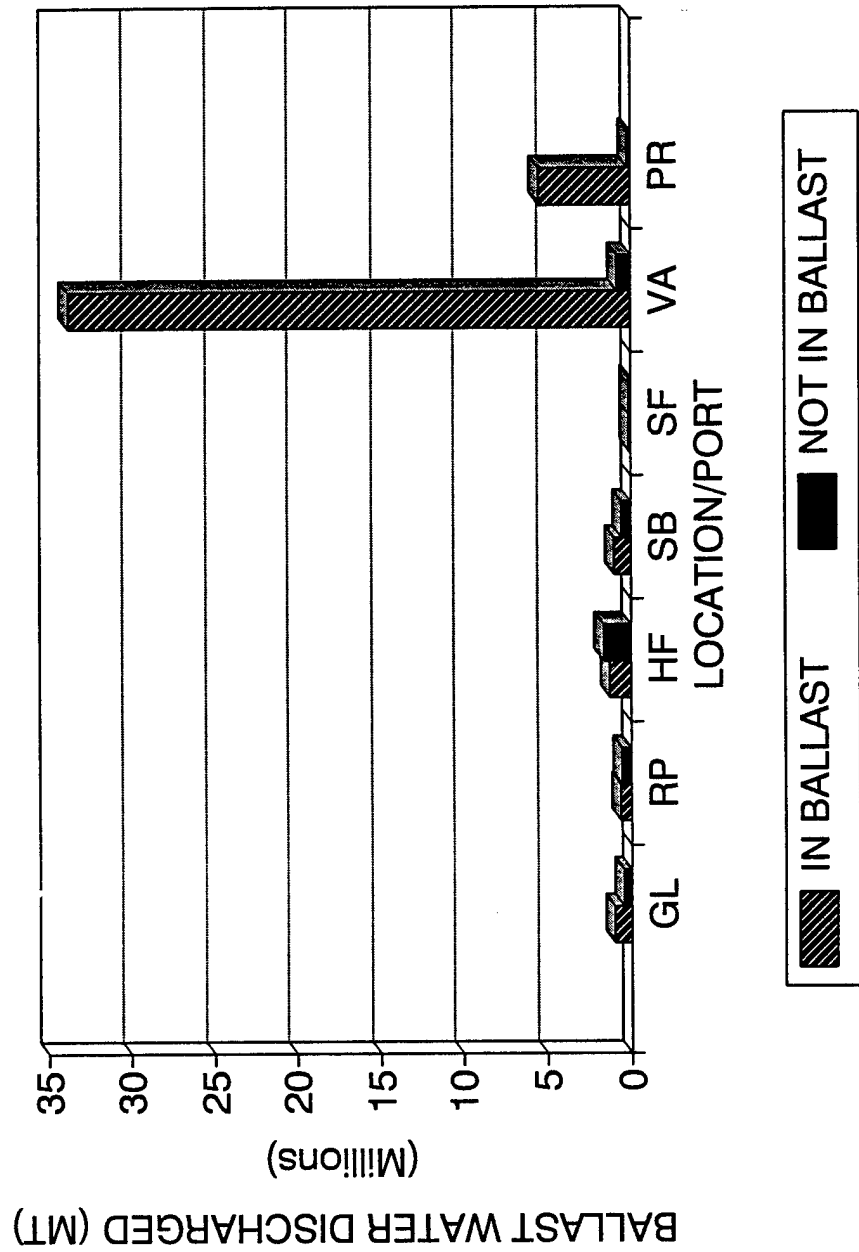

FIGURE 18

# BALLAST WATER DISCHARGED IN THE GREAT LAKES AND SELECTED PORTS

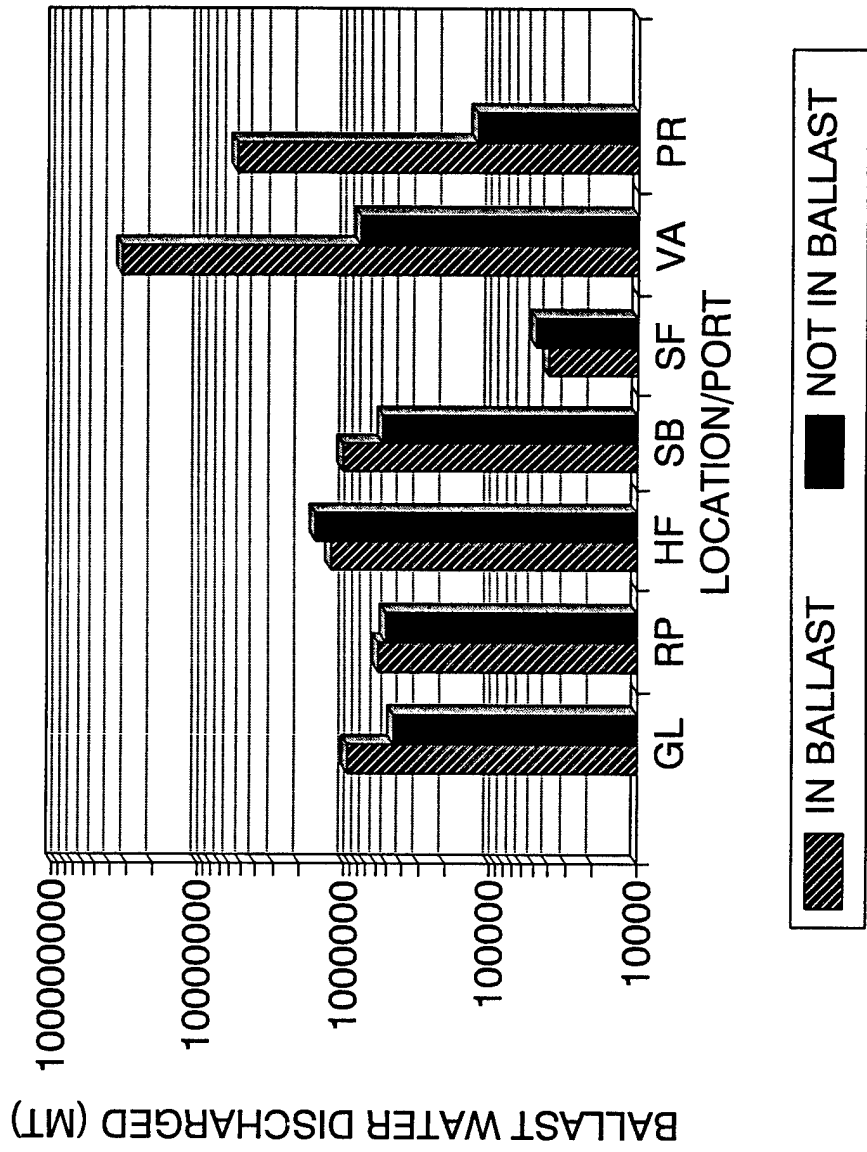

FIGURE 19

Table 1. Vessel and ballast water data for all vessels entering the St. Lawrence Seaway in 1991.

NRT: net register tonnage; GRT: gross register tonnage; BWCAP: ballast water capacity; NRT and GRT are recorded in register tons, BWCAP in metric tons; from Lloyd's Register. Data are presented (N: number of vessels; SUM: total quantity for all N; MEAN: average quantity per vessel; SD: standard deviation around the MEAN) for all vessels (ALL), bulk carriers (BULK), general cargo carriers (GC) and tankers (TANK).

VESSEL TYPE	DATA	NRT	GRT	BWCAP
ALL	N	427	427	212
	SUM	3458015	5628655	1876485
	MEAN	8098	13182	8851
	SD	3486	5069	5503
BULK	N	267	267	130
	SUM	2695985	4277818	1517982
	MEAN	10097	16022	11677
	SD	2560	3716	5227
GC	N	89	89	48
	SUM	449391	759377	194008
	MEAN	5049	8532	4042
	SD	1528	2521	1379
TANK	N	56	56	28
	SUM	264450	479298	147842
	MEAN	4722	8559	5280
	SD	2360	3878	1331

Table 2. Vessel and ballast water data for all vessels carrying acknowledged ballast entering the St. Lawrence Seaway in 1991.

NRT: net register tonnage; GRT: gross register tonnage; BWCAP: ballast water capacity; NRT and GRT are recorded in register tons, BWCAP in metric tons; from Lloyd's Register. Data are presented (N: number of vessels; SUM: total quantity for all N; MEAN: average quantity per vessel; SD: standard deviation around the MEAN) for all vessels (ALL), bulk carriers (BULK), general cargo carriers (GC) and tankers (TANK).

---

VESSEL TYPE	DATA	NRT	GRT	BWCAP
ALL	N	143	143	69
	SUM	1216883	1905357	600058
	MEAN	8510	13242	8696
	SD	3315	4757	4644
BULK	N	92	92	47
	SUM	951280	1461855	498278
	MEAN	10340	15890	10602
	SD	2491	3532	4334
GC	N	38	38	17
	SUM	197262	320719	68289
	MEAN	5191	8440	4017
	SD	1244	1772	1567
TANK	N	13	13	5
	SUM	68341	122783	33491
	MEAN	5257	9445	6698
	SD	2450	4486	301

---

Table 3. Vessel and ballast water data for all vessels carrying unacknowledged ballast entering the St. Lawrence Seaway in 1991.

NRT: net register tonnage; GRT: gross register tonnage; BWCAP: ballast water capacity; NRT and GRT are recorded in register tons, BWCAP in metric tons; from Lloyd's Register) for vessels carrying unacknowledged ballast. Data are presented (N: number of vessels; SUM: total quantity for all N; MEAN: average quantity per vessel; SD: standard deviation around the MEAN) for all vessels (ALL), bulk carriers (BULK), general cargo carriers (GC) and tankers (TANK).

VESSEL TYPE	DATA	NRT	GRT	BWCAP
ALL	N	284	284	142
	SUM	2241132	3723298	1284826
	MEAN	7891	13110	9048
	SD	3551	5218	5859
BULK	N	175	175	82
	SUM	1744705	2815963	1028003
	MEAN	9970	16091	12537
	SD	2587	3807	5409
GC	N	51	51	31
	SUM	252129	438658	125819
	MEAN	4944	8601	4059
	SD	1701	2956	1260
TANK	N	43	43	23
	SUM	196109	356515	114351
	MEAN	4561	8291	4972
	SD	2308	3632	1268

Table 4. Vessel data, ballast on board (BOB) and ballast intended for discharge (DIS) for all vessels entering the St. Lawrence Seaway in 1991.

Vessel statistics derived from Ballast Water Exchange Reports (BWERS) for all vessels (ALL), bulk carriers (BULK), general cargo carriers (GC) and tankers (TANK) Net and Gross Register Tonnage (NRT and GRT respectively, in register tons; all other quantities in metric tons), ballast water capacity (BWCAP), ballast water on board (BOB) and ballast water intended for discharge (DIS) are presented (N: number of records; SUM: total; MEAN: arithmetic mean; SD: standard deviation of the sample). NRT, GRT and BWCAP from Lloyd's Register.

VESSEL TYPE	NRT	GRT	BWCAP	BOB	DIS
ALL					
N	202	202	96	138	42
SUM	1542054	2492780	779331	591630	245434
MEAN	7634	12341	8118	4287	5844
SD	3304	4867	5496	4125	4650
BULK					
N	113	113	51	80	30
SUM	1097703	1734828	595399	503868	211541
MEAN	9714	15353	11674	6298	7051
SD	2227	3441	5357	4280	4539
GC					
N	60	60	32	47	11
SUM	341010	544944	125126	68413	28418
MEAN	5684	9082	3910	1456	2584
SD	2323	3323	1540	1409	3429
TANK					
N	18	18	8	2	1
SUM	69586	133313	44848	5745	5475
MEAN	3866	7406	5606	2873	5475
SD	2216	3917	1147	2603	0

Table 5. Vessel data, ballast on board (BOB) and ballast intended for discharge (DIS) for vessels with acknowledged ballast entering the St. Lawrence Seaway in 1991.

Vessel statistics derived from Ballast Water Exchange Reports (BWERS) for all vessels (ALL), bulk carriers (BULK), general cargo carriers (GC) and tankers (TANK). Net and Gross Register Tonnage (NRT and GRT respectively, in register tons; all other quantities in metric tons), ballast water capacity (BWCAP), ballast water on board (BOB) and ballast water intended for discharge (DIS) are presented (N: number of records; SUM: total; MEAN: arithmetic mean; SD: standard deviation of the sample). NRT, GRT and BWCAP from Lloyd's Register.

---

VESSEL TYPE

ALL	NRT	GRT	BWCAP	BOB	DIS
N	85	85	39	79	34
SUM	723498	1115971	333201	504016	224101
MEAN	8512	13129	8544	6380	6591
SD	2986	4351	4804	4112	4703
BULK					
N	59	59	29	55	24
SUM	583332	891527	292907	452204	192179
MEAN	9887	15111	10100	8222	8007
SD	2370	3481	4500	3440	4382
GC					
N	24	24	9	23	9
SUM	131990	208871	33457	46337	26447
MEAN	5500	8703	3717	2015	2939
SD	1308	1568	1824	1605	3676
TANK					
N	2	2	1	1	1
SUM	8176	15573	6837	5475	5475
MEAN	4088	7787	6837	5475	5475
SD	2919	6188	0	0	0

---

Table 6. Vessel data, ballast on board (BOB) and ballast intended for discharge (DIS) for vessels with unacknowledged ballast entering the St. Lawrence Seaway in 1991.

Vessel statistics derived from Ballast Water Exchange Reports (BWERS) for all vessels (ALL), bulk carriers (BULK), general cargo carriers (GC) and tankers (TANK). Net and Gross Register Tonnage (NRT and GRT respectively, in register tons; all other quantities in metric tons), Ballast Water Capacity (BWCAP) and Ballast Water on board (BOB) are presented (N: number of records; SUM: total; MEAN: average; SD: standard deviation). NRT, GRT and BWCAP from Lloyd's Register.

VESSEL TYPE	NRT	GRT	BWCAP	BOB
ALL				
N	117	117	57	59
SUM	818556	1376809	446130	87614
MEAN	6996	11768	7827	1485
SD	3376	5134	5906	1857
BULK				
N	54	54	22	25
SUM	514371	843301	302492	51664
MEAN	9525	15617	13750	2067
SD	2044	3378	5460	2553
GC				
N	36	36	23	24
SUM	209020	336073	91669	22076
MEAN	5806	9335	3986	920
SD	2796	4075	1406	912
TANK				
N	16	16	7	1
SUM	61410	117740	38011	270
MEAN	3838	7359	5430	270
SD	2111	3529	1121	0

Table 7. Acknowledged ballast water for vessels entering St. Lawrence Seaway: Calculated ballast water related to gross register tonnage.

Mean quantities and percentages of ballast water capacity (BWCAP) were determined by regressing capacities onto Gross Register Tonnages (GRT; in register tons) (N = number of data pairs) of vessels reported on Ballast Water Exchange Reports for all vessels (ALL), bulk carriers (BULK), general cargo carriers (GC) and tankers (TANK). Mean GRT (entered as X) was determined arithmetically, and the appropriate regression equation given below (R-squared shows the strength of the relationships) was used to estimate the BWCAP (CALC (calculated) BWCAP: Y in the equation). Percentage BWCAP of MEAN GRT (%GRT) was also calculated.

VESSEL TYPE	N	EQUATION	MEAN GRT	CALC BWCAP	%GRT	R-SQUARED
ALL	39	$Y = 0.927743 X - 4666.73$	14239	8543	60.0	0.681399
BULK	29	$Y = 0.921642 X - 4666.73$	15810	10100	63.9	0.556134
GC	9	$Y = 0.587045 X - 1687.74$	9207	3717	40.4	0.328341
TANK *	1		13974	6837	48.9	

\* N = 1, no regression possible; actual quantities are presented.

Table 8. Unacknowledged ballast water for vessels entering St. Lawrence Seaway: Calculated ballast water related to gross register tonnage.

Mean quantities and percentages of ballast water capacity (BWCAP) were determined by regressing capacities onto Gross Register Tonnages (GRT; in register tons) (N = number of data pairs) of vessels reported on Ballast Water Exchange Reports for all vessels (ALL), bulk carriers (BULK), general cargo carriers (GC) and tankers (TANK). Mean GRT (entered as X) was determined arithmetically, and the appropriate regression equation given below (R-squared shows the strength of the relationships) was used to estimate the BWCAP (CALC (calculated) BWCAP: Y from the equation). Percentage BWCAP of MEAN GRT (%GRT) was also calculated.

VESSEL TYPE	N	EQUATION	MEAN GRT	CALC BWCAP	%GRT	R-SQUARED
ALL	57	$Y = 1.097115 X - 6195.54$	12781	7827	61.2	0.71006
BULK	22	$Y = 1.178668 X - 5606.23$	16422	13750	83.7	0.719723
GC	23	$Y = 0.309921 X + 759.9626$	10408	3986	38.3	0.733368
TANK*	7	$Y = -2.32662 \text{ GRT} + 31267.59$	11105	5430	48.9	0.989768

\* The negative slope in this equation, indicating that BWCAP decreases with increasing GRT, is a result of the 7 observations being derived from only 4 vessels of similar GRT which do exhibit this negative relationship over a small range of size. It is suggested that this equation is suitable only for the determination of mean BWCAP for this data set, and that this relationship should not be used to estimate tanker BWCAP from GRT in other instances.

Table 9. Acknowledged ballast water for vessels entering St. Lawrence Seaway: Calculated ballast on board related to ballast water capacity.

Mean quantities and percentages of ballast water carried on board were determined by regressing quantities carried onto ballast capacities (N = number of data pairs) as reported on Ballast Water Exchange Reports for all vessels (ALL), bulk carriers (BULK), general cargo carriers (GC) and tankers (TANK); all quantities in metric tons. Mean Ballast Water Capacity (MEAN BWCAP: entered as X) was determined arithmetically, and the appropriate regression equation given below (R-squared shows the strength of the relationships) was used to estimate the quantity of ballast water carried (CALC (calculated) BOB: Y from the equation). Percentage of MEAN BWCAP carried (%CAP) was also calculated.

VESSEL TYPE	N	EQUATION	MEAN BWCAP	CALC BOB	%CAP	R-SQUARED
ALL	37	$Y = 0.712024 X + 1358.127$	8639	7509	86.9	0.609652
BULK	28	$Y = 0.584361 X + 3079.52$	10070	8964	89.0	0.464896
GC	8	$Y = 0.75618 X - 243.635$	3855	2671	69.3	0.499942
TANK *	1		6837	5475	80.1	

\* N = 1, no regression possible; actual quantities are presented.

Table 10. Unacknowledged ballast water for vessels entering St. Lawrence Seaway: Calculated ballast on board related to ballast water capacity.

Mean quantities and percentages of ballast water carried on board were determined by regressing quantities carried onto ballast capacities (N = number of data pairs) as reported on Ballast Water Exchange Reports for all vessels (ALL), bulk carriers (BULK), general cargo carriers (GC) and tankers (TANK); all quantities in metric tons. Mean Ballast Water Capacity (MEAN BWCAP: entered as X) was determined arithmetically, and the appropriate regression equation given below (R-squared shows the strength of the relationships) was used to estimate the quantity of ballast water carried (CALC (calculated) BOB: Y from the equation). Percentage of MEAN BWCAP carried (%CAP) was also calculated.

VESSEL TYPE	N	EQUATION	MEAN BWCAP	CALC BOB	%CAP	R-SQUARED
ALL	32	$Y = 0.103505 X + 939.7976$	8290	1798	21.7	0.087273
BULK	12	$Y = -0.07847 X + 4206.937$	15474	2993	19.3	0.016065
GC	15	$Y = -0.0193 X + 1068.342$	4298	985	22.9	0.000444
TANK *	1		4343	279	6.2	

\* N = 1, no regression possible; actual quantities are presented

Table 11. Acknowledged ballast water for vessels entering the St. Lawrence Seaway: Calculated discharged water related to ballast on board.

Mean quantities and percentages of ballast water intended for discharge were determined by regressing quantities to be discharged onto quantities carried (N = number of data pairs) as reported on Ballast Water Exchange Reports for all vessels (ALL), bulk carriers (BULK), general cargo carriers (GC) and tankers (TANK) (all quantities in metric tons). Mean Ballast on Board (MEAN BOB: entered as X) was determined arithmetically, and the appropriate regression equation given below (R-squared shows the strength of the relationships) was used to estimate the quantity discharged (CALC (calculated) DIS: Y from the equation). Percentage of MEAN BOB discharged (%DIS) was also calculated.

VESSEL TYPE	N	EQUATION	MEAN BOB	CALC DIS	%DIS	R-SQUARED
ALL	34	$Y = 1.027238 X - 561.544$	6963	6591	94.7	0.957753
BULK	24	$Y = 1.068901 X - 1021.1$	8447	8008	94.8	0.940725
GC	9	$Y = 1.000831 X - 236.526$	3172	2938	92.6	0.977508
TANK *	1		5475	5475	100	

\* N = 1, no regression possible; actual quantities are presented

Table 12. Unacknowledged ballast water for vessels entering the St. Lawrence Seaway: Calculated discharged water related to ballast on board.

Mean quantities and percentages of ballast water intended for discharge were determined by regressing quantities to be discharged onto quantities carried (N = number of data pairs) as reported on Ballast Water Exchange Reports for all vessels (ALL), bulk carriers (BULK) and general cargo carriers (GC); all quantities in metric tons. Mean Ballast on Board (MEAN BOB: entered as X) was determined arithmetically, and the appropriate regression equation given below (R-squared shows the strength of the relationships) was used to estimate the quantity discharged (CALC (calculated) DIS: Y from the equation). Percentage of MEAN BOB discharged (%DIS) was also calculated.

---

VESSEL TYPE	N	EQUATION	MEAN BOB	CALC DIS	%DIS	R- SQUARED
ALL	8	$Y = 1.007184 X - 245.901$	2892	2667	92.2	0.971062
BULK	6	$Y = 1.002945 X - 237.171$	3454	3227	93.4	0.967556
GC *	2		1205	986	81.8	

---

\* N = 2, no regression; arithmetic means are presented

Table 13. Estimated quantity of ballast water (in metric tons) intended for discharge (DIS) by vessels carrying acknowledged ballast as they entered the Seaway in transit to the Great Lakes and the listed ports.

N: the number of vessels

MEAN GRT (GRT): average Gross Register Tonnage (in register tons)

# OF PORTS (NP): average number of ports visited per vessel (in the Great Lakes category all ports = 1.0 ports)

% CONV FACT (CF): percentage conversion factor relating GRT and ballast water quantity intended for discharge

CALC MEAN DIS (CMD): calculated average ballast quantity intended for discharge per vessel per port;  $CMD = (GRT \times CF) / NP$

CALC TOTAL DIS (CTD): total ballast quantity intended for discharge by all vessels in each port;  $CTD = N \times CMD$

PORT	N	MEAN GRT	# OF PORTS	% CONV FACT	CALC MEAN DIS	CALC TOTAL DIS
Great Lakes	143	13324	1.0	49.4	6582	941226
U.S. Great Lakes Ports						
Detroit	13	12045	1.4	49.4	4250	55250
Chicago	4	14476	1.5	49.4	4767	19068
Cleveland	2	17036	1.0	49.4	8416	16832
Duluth/Superior	22	13474	1.1	49.4	605	1133122
Canadian Great Lakes Ports						
Hamilton	30	13238	1.2	49.4	5450	163500
Windsor	0					
Sarnia	14	13835	1.0	49.4	6834	95676
Thunder Bay	19	13051	1.1	49.4	5861	111359

Table 14. Estimated quantity of ballast water (in metric tons) intended for discharge (DIS) by vessels carrying unacknowledged ballast as they entered the Seaway in transit to the Great Lakes and the listed ports.

N: the number of vessels

MEAN GRT (GRT): average Gross Register Tonnage (in register tons)

# OF PORTS (NP): average number of ports visited per vessel (in the Great Lakes category all ports = 1.0 ports)

% CONV FACT (CF): percentage conversion factor relating GRT and ballast water quantity intended for discharge

CALC MEAN DIS (CMD): calculated average ballast quantity intended for discharge per vessel per port;  $CMD = (GRT \times CF) / NP$

CALC TOTAL DIS (CTD): calculated total ballast quantity intended for discharge by all vessels in each port;  $CTD = N \times CMD$

---

PORT	N	MEAN GRT	# OF PORTS	% CONV FACT	CALC MEAN DIS	CALC TOTAL DIS
Great Lakes	284	13110	1.0	12.2	1599	454235
U.S. Great Lakes Ports						
Detroit	111	14982	4.1	12.1	446	49506
Chicago	95	14048	3.9	12.2	439	41705
Cleveland	87	14770	3.9	12.2	462	40194
Duluth/Superior	42	16167	4.2	12.2	497	20874
Canadian Great Lakes Ports						
Hamilton	73	13340	3.1	12.2	525	38325
Windsor	4	13602	2.3	12.2	721	2884
Sarnia	18	12416	2.8	12.2	541	9738
Thunder Bay	38	14366	3.7	12.2	474	18012

---

Table 15. Estimated quantity of ballast water (in metric tons) intended for discharge by bulk carriers (BULK), general cargo carriers (GC) and tankers (TANK) carrying acknowledged ballast as they entered the Seaway in transit to the Great Lakes and the listed ports.

Quantities have been adjusted to account for multiple port visits and have been derived based on the appropriate conversion factors.

PORT	BULK	GC	TANK	TOTAL
Great Lakes	787980	83068	48126	919174
U.S. Great Lakes Ports				
Detroit	46716	12754	0	59470
Chicago	23358	1822	0	25180
Cleveland	15572	0	0	15572
Duluth/Superior	116790	12754	0	129544
Canadian Great Lakes Ports				
Hamilton	163506	16398	0	179904
Windsor	0	0	0	0
Sarnia	38930	1822	29616	70368
Thunder Bay	77860	16398	0	94258

Table 16. Estimated quantity of ballast water (in metric tons) intended for discharge by bulk carriers (BULK), general cargo carriers (GC) and tankers (TANK) carrying unacknowledged ballast as they entered the Seaway in transit to the Great Lakes and the listed ports.

Quantities have been adjusted to account for multiple port visits and have been derived based on the appropriate conversion factors.

---

PORT	BULK	GC	TANK	TOTAL
Great Lakes	425250	31569	0	456819
U.S. Great Lakes Ports				
Detroit	63756	3852	0	67608
Chicago	59202	2354	0	61556
Cleveland	52371	2354	0	54725
Duluth/Superior	28083	642	0	28725
Canadian Great Lakes Ports				
Hamilton	31878	2782	0	34660
Windsor	2277	214	0	2491
Sarnia	5313	0	0	5313
Thunder Bay	20493	1712	0	22205

---

Table 17. Number of vessel arrivals (#ARR), number (#BT) and percentage (%BT) of vessel arrivals carrying acknowledged ballast in 1991 for all Great Lakes ports considered in the study.

Data presented are from St. Lawrence Seaway Authority (SLSA) and Bureau of Census records (BC).

---

Port	SLSA			BC		
	#ARR	#BT	%BT	#ARR	#BT	%BT
U.S. Great Lakes Ports						
Detroit	124	13	10.5	133	18	13.5
Chicago	99	4	4.0	103	7	6.9
Cleveland	89	2	2.2	96	1	1.0
Duluth/Superior	64	22	34.4	70	25	35.7
Canadian Great Lakes Ports						
Hamilton	103	30	29.1			
Windsor	4	0	0			
Sarnia	32	14	43.8			
Thunder Bay	57	19	33.3			

---

Table 18. Quantities of ballast water (in metric tons) by source (Food and Agricultural Organization [FAO] Waters of the World, codes A, C, G) carried by vessels entering the St. Lawrence Seaway with acknowledged ballast in 1991 (see Figure 10)

Data derived from Ballast Water Exchange Reports from vessels entering the St. Lawrence Seaway in 1991.

---

Ballast Water Source:		
FAO Code	Location	Quantity
A	Northwest Atlantic	94216
C	Mediterranean Sea	12681
G	West Central Atlantic	4452
ATL	Atlantic (Unspecified)	359333
RP	St. Lawrence River Ports, Quebec City to Montreal	25969
	Total	496651

---

Table 19. Quantities of ballast water(in metric tons) by source (Food and Agricultural Organization [FAO] Waters of the World, codes A, B, H) carried by vessels entering the St. Lawrence Seaway with unacknowledged ballast in 1991 (see Figure 11).

Data derived from Ballast Water Exchange Reports from vessels entering the St. Lawrence Seaway in 1991.

---

Ballast Water Source:		Quantity
FAO Code	Location	
A	Northwest Atlantic	13111
B	Northeast Atlantic	146
H	Indian Ocean	142
ATL	Atlantic (Unspecified)	59175
PAC	Pacific (Unspecified)	843
RP	St. Lawrence River Ports, Quebec City to Montreal	6158
GL	Great Lakes	270
	Total	79845

---

Table 20. Sources (FAO Water of the World: A,B,C) and quantities (in metric tons) of ballast intended to be discharged in the Great Lakes ports indicated.

A: Northwest Atlantic; B: Northeast Atlantic; C: Mediterranean Sea; ATL: Atlantic Ocean (unspecified); RP: St. Lawrence River and ports between Quebec City and Montreal. Data derived from Ballast Water Exchange Reports.

Source	A	B	C	ATL	RP	Total
Destination						
UNITED STATES						
Chicago				9769		9769
Cleveland		146				146
Detroit	16674			21248		37922
Duluth/Superior			12150	30784		42934
Subtotal	16674	146	12150	61801		90771
CANADA						
Hamilton	29122			37575		52136
Sarnia	4323			5475		9798
Thunder Bay	15964			43193	21144	80301
Windsor						
Subtotal	49409			86243	21144	142335
TOTAL	66083	146	12150	148044	21144	233006

Table 21. Vessel data for all vessels approaching St. Lawrence River ports (Quebec City to Montreal inclusive; ECAREG records) in 1991.

NRT: net register tonnage; GRT: gross register tonnage; BWCAP: ballast water capacity; NRT and GRT are recorded in register tons, BWCAP in metric tons; data from Lloyd's Register. Data are presented (N: number of vessels; SUM: total quantity for all N; MEAN: average quantity per vessel; SD: standard deviation around the MEAN) for all vessels (ALL), bulk carriers (BULK), container carriers (CONT), general cargo carriers (GC) and tankers (TANK).

VESSEL TYPE	DATA	NRT	GRT	BWCAP
ALL	N	328	328	106
	SUM	3492958	6013338	1240077
	MEAN	10649	18333	11699
	SD	8158	12727	9967
BULK	N	82	82	29
	SUM	894622	1417274	470124
	MEAN	10910	17284	16211
	SD	5407	8949	11433
CONT	N	133	133	52
	SUM	1793921	3224023	610173
	MEAN	13488	24241	11734
	SD	8128	10852	6104
GC	N	88	88	20
	SUM	417771	724001	75698
	MEAN	4747	8227	3785
	SD	2271	3961	1229
TANK	N	22	22	5
	SUM	378464	633696	84082
	MEAN	17203	28804	16816
	SD	14949	24154	23652

Table 22. Vessel data for vessels approaching St. Lawrence River ports (Quebec City to Montreal inclusive; ECAREG records) carrying acknowledged ballast in 1991.

NRT: net register tonnage; GRT: gross register tonnage; BWCAP: ballast water capacity; NRT and GRT are recorded in register tons, BWCAP in metric tons; from Lloyd's Register). Data are presented (N: number of vessels; SUM: total quantity for all N; MEAN: average quantity per vessel; SD: standard deviation around the MEAN) for all vessels (ALL), bulk carriers (BULK), container carriers (CONT), general cargo carriers (GC) and tankers (TANK).

---

VESSEL TYPE	DATA	NRT	GRT	BWCAP
ALL	N	82	82	19
	SUM	665847	1073771	155214
	MEAN	8120	13095	8169
	SD	6733	10629	7299
BULK	N	39	39	11
	SUM	405648	654989	132877
	MEAN	10401	16795	12080
	SD	3631	7015	7371
GC	N	37	37	8
	SUM	166863	273155	22337
	MEAN	4510	7383	2792
	SD	2214	3321	1371
TANK	N	6	6	0
	SUM	93336	145627	0
	MEAN	15556	24271	
	SD	18277	27221	

---

Table 23. Vessel data for vessels approaching St. Lawrence River ports (Quebec City to Montreal inclusive; ECAREG records) carrying unacknowledged ballast in 1991.

NRT: net register tonnage; GRT: gross register tonnage; BWCAP: ballast water capacity; NRT and GRT are recorded in register tons, BWCAP in metric tons. Data are presented (N: number of vessels; SUM: total quantity for all N; MEAN: average quantity per vessel; SD: standard deviation around the MEAN) for all vessels (ALL), bulk carriers (BULK), container carriers (CONT), general cargo carriers (GC) and tankers (TANK).

VESSEL TYPE	DATA	NRT	GRT	BWCAP
ALL	N	222	222	84
	SUM	2671628	4684136	1040736
	MEAN	12034	21100	12390
	SD	8528	12910	10071
BULK	N	33	33	17
	SUM	407822	639434	301063
	MEAN	12358	19377	17710
	SD	6507	10443	12291
CONT	N	133	133	52
	SUM	1793921	3224023	610173
	MEAN	13488	24241	11734
	SD	8128	10852	6104
GC	N	43	43	10
	SUM	220518	395338	45418
	MEAN	5128	9194	4542
	SD	2227	4178	25
TANK	N	13	13	5
	SUM	249367	425341	84082
	MEAN	19182	32719	16816
	SD	14545	24386	23652

Table 24. Mean quantities and percentages of ballast water capacity (BWCAP, in metric tons) for vessels approaching St. Lawrence River ports (Quebec City to Montreal inclusive; ECAREG records) carrying acknowledged ballast.

BWCAP was determined by regressing capacities onto Gross Register Tonnages (GRT; in register tons) (N = number of data pairs) for all vessels (ALL), bulk carriers (BULK) and general cargo carriers (GC). Mean GRT (entered as X) was determined arithmetically, and the appropriate regression equation given below (R-squared shows the strength of the relationships) was used to estimate the BWCAP (CALC (calculated) BWCAP: Y from the equation). Percentage BWCAP of MEAN GRT (%GRT) was also calculated.

VESSEL TYPE	N	EQUATION	MEAN GRT	CALC BWCAP	%GRT	R- SQUARED
ALL	19	$Y = 0.960725 X - 3741.41$	12398	8170	65.9	0.783346
BULK	11	$Y = 1.218419 X - 7877.21$	16379	12079	73.7	0.781629
GC	8	$Y = 0.269721 X + 925.01$	6922	2792	40.3	0.6298

Table 25. Mean quantities and percentages of ballast water capacity (BWCAP, in metric tons) for vessels approaching St. Lawrence River ports (Quebec City to Montreal inclusive; ECAREG records) carrying unacknowledged ballast.

BWCAP was determined by regressing capacities onto Gross Register Tonnages (GRT; in register tons) (N = number of data pairs) for all vessels (ALL), bulk carriers (BULK), container carriers (CONT), general cargo carriers (GC) and tankers (TANK). Mean GRT (entered as X) was determined arithmetically, and the appropriate regression equation given below (R-squared shows the strength of the relationships) was used to estimate the BWCAP (CALC (calculated) BWCAP: Y from the equation). Percentage BWCAP of MEAN GRT (%GRT) was also calculated.

VESSEL TYPE	N	EQUATION	MEAN GRT	CALC BWCAP	%GRT	R-SQUARED
ALL	84	$Y = 0.855247 X - 6669.27$	22285	12390	55.6	0.885318
BULK	17	$Y = 1.021752 X - 5051.67$	22277	17710	79.5	0.946951
CONT	52	$Y = 0.783647 X - 6305.18$	23020	11734	51.0	0.993918
GC	10	$Y = 0.02196 X + 4239.26$	13777	4542	33.0	1.0
TANK	5	$Y = 0.860245 X - 10441.2$	31686	16817	53.1	0.963184

Table 26. Estimated quantity of ballast water (in metric tons) discharged by all vessels (ALL), bulk carriers (BULK), general cargo carriers (GC) and tankers (TANK) carrying acknowledged ballast to ports on the St. Lawrence River between Quebec City and Montreal (collectively termed the Riverport).

N: the number of vessels

MEAN GRT (GRT): average Gross Register Tonnage (in register tons)

% CONV FACT (CF): percentage conversion factor relating GRT and estimated quantity of ballast water discharged

CALC MEAN DIS (CMD): calculated average ballast quantity intended for discharge per vessel per port;  $CMD = GRT \times CF$

CALC TOTAL DIS (CTD): calculated total ballast quantity intended for discharge by all vessels in each port;  $CTD = N \times CMD$

---

VESSEL TYPE	N	MEAN GRT	% CONV FACT	CALC MEAN DIS	CALC TOTAL DIS
ALL	82	13095	54.2	7097	581954
BULK	39	16795	62.2	10446	407394
GC	37	7383	25.9	1912	70744
TANK	6	24271	54.2	13155	78930

---

Table 27. Estimated quantity of ballast water (in metric tons) discharged by all vessels (ALL), bulk carriers (BULK), container carriers (CONT) general cargo carriers (GC) and tankers (TANK) carrying unacknowledged ballast to ports on the St. Lawrence River between Quebec City and Montreal (collectively termed the Riverport).

N: the number of vessels

MEAN GRT (GRT): average Gross Register Tonnage (in register tons)

% CONV FACT (CF): percentage conversion factor relating GRT and estimated quantity of ballast water discharged

CALC MEAN DIS (CMD): calculated average ballast quantity intended for discharge per vessel per port;  $CMD = GRT \times CF$

CALC TOTAL DIS (CTD): calculated total ballast quantity intended for discharge by all vessels in each port;  $CTD = N \times CMD$

VESSEL TYPE	N	MEAN GRT	% CONV FACT	CALC MEAN DIS	CALC TOTAL DIS
ALL	222	21100	11.1	2342	519924
BULK	33	19377	14.3	2771	91443
CONT	133	24241	*	303*	40299
GC	43	9194	6.2	570	24510
TANK	13	32719	3.0	982	12766

\* CMD from Shipping Study (see text).

Table 28. Mean gross register tonnage (in register tons) for all vessels (ALL), vessels carrying acknowledged (BT) and unacknowledged ballast (XBT) bound for Halifax in 1991 (from Canadian Coast Guard (ECAREG) records).

Data are presented (N: number of vessels; SUM: total quantity for all N; MEAN: average quantity per vessel; SD: standard deviation around the MEAN) for all vessels (ALL), bulk carriers (BULK), container carriers (CONT), general cargo carriers (GC) and tankers (TANK).

VESSEL TYPE	DATA	ALL	BT	XBT
ALL	N	953	136	796
	SUM	24712205	2282817	22177170
	MEAN	25931	16785	17861
	SD	19191	18655	18139
BULK	N	136	94	40
	SUM	2487198	1534473	914749
	MEAN	18288	16324	22869
	SD	12099	13293	7216
CONT	N	519		
	SUM	15862125		
	MEAN	30563		
	SD	17254		
GC	N	118	20	92
	SUM	1066918	154478	875628
	MEAN	9042	7724	9518
	SD	8664	4694	9448
TANK	N	89	11	70
	SUM	3701264	479503	3103309
	MEAN	41587	43591	44333
	SD	24391	44448	18598

Table 29. Estimated quantity of ballast water (in metric tons) discharged (DIS) by all vessels (ALL), bulk carriers (BULK), general cargo carriers (GC) and tankers (TANK) carrying acknowledged ballast to Halifax in 1991.

N: the number of vessels

MEAN GRT (GRT): average Gross Register Tonnage (in register tons)

% CONV FACT (CF): percentage conversion factor relating GRT and estimated quantity of ballast water discharged

CALC MEAN DIS (CMD): calculated average ballast quantity intended for discharge per vessel per port;  $CMD = GRT \times CF$

CALC TOTAL DIS (CTD): calculated total ballast quantity intended for discharge by all vessels in each port;  $CTD = N \times CMD$

VESSEL TYPE	N	MEAN GRT	% CONV FACT	CALC MEAN DIS	CALC TOTAL DIS
ALL	136	16785	54.2	9097	1237192
BULK	94	16324	62.2	10154	954476
GC	20	7724	25.9	2001	40020
TANK	11	43591	54.2	23626	259886

Table 30. Estimated quantity of ballast water (in metric tons) discharged (DIS) by all vessels (ALL), bulk carriers (BULK), container carriers (CONT) general cargo carriers (GC) and tankers (TANK) carrying unacknowledged ballast to Halifax in 1991.

N: the number of vessels

MEAN GRT (GRT): average Gross Register Tonnage (in register tons)

% CONV FACT (CF): percentage conversion factor relating GRT and estimated quantity of ballast water discharged

CALC MEAN DIS (CMD): calculated average ballast quantity intended for discharge per vessel per port;  $CMD = GRT \times CF$

CALC TOTAL DIS (CTD): calculated total ballast quantity intended for discharge by all vessels in each port;  $CTD = N \times CMD$

---

VESSEL TYPE	N	MEAN GRT	% CONV FACT	CALC MEAN DIS	CALC TOTAL DIS
ALL	796	17861	11.1	1983	1578468
BULK	40	22869	14.3	3270	130800
CONT	519	30563	*	303*	157257
GC	92	9518	6.2	590	54280
TANK	70	44333	3.0	1330	93100

---

\* CMD from Shipping Study (see text).

Table 31. Mean gross register tonnage (GRT; in register tons) of vessels carrying acknowledged (BT) and unacknowledged ballast (XBT) bound for St. John in 1991 (from Canadian Coast Guard (ECAREG) records).

Data are presented (N: number of vessels; SUM: total quantity for all N; MEAN: average quantity per vessel; SD: standard deviation around the MEAN) for all vessels (ALL), bulk carriers (BULK), container carriers (CONT), general cargo carriers (GC) and tankers (TANK).

VESSEL TYPE	DATA	ALL	BT	XBT
ALL	N	338	145	179
	SUM	6850873	1850168	4862005
	MEAN	20269	12760	27162
	SD	25086	7431	32233
BULK	N	111	77	30
	SUM	1700293	1158687	485712
	MEAN	15318	15048	16190
	SD	6411	7221	3492
CONT	N	19		
	SUM	335027		
	MEAN	17633		
	SD	4709		
GC	N	103	41	56
	SUM	954252	261630	653334
	MEAN	9265	6381	11667
	SD	6000	3561	6493
TANK	N	89	18	68
	SUM	3627240	358925	3240303
	MEAN	40756	19940	47652
	SD	40983	3194	44588

Table 32. Estimated quantity of ballast water (in metric tons) discharged (DIS) by all vessels (ALL), bulk carriers (BULK), general cargo carriers (GC) and tankers (TANK) carrying acknowledged ballast to St. John in 1991.

N: the number of vessels

MEAN GRT (GRT): average Gross Register Tonnage (in register tons)

% CONV FACT (CF): percentage conversion factor relating GRT and estimated quantity of ballast water discharged

CALC MEAN DIS (CMD): calculated average ballast quantity intended for discharge per vessel per port;  $CMD = GRT \times CF$

CALC TOTAL DIS (CTD): calculated total ballast quantity intended for discharge by all vessels in each port;  $CTD = N \times CMD$

VESSEL TYPE	N	MEAN GRT	% CONV FACT	CALC MEAN DIS	CALC TOTAL DIS
ALL	145	12760	54.2	6916	1002820
BULK	77	15048	62.2	9360	720720
GC	41	6381	25.9	1653	67773
TANK	18	19940	54.2	10807	194526

Table 33. Estimated quantity of ballast water (in metric tons) discharged (DIS) by all vessels (ALL), bulk carriers (BULK), container carriers (CONT) general cargo carriers (GC) and tankers (TANK) carrying unacknowledged ballast to St. John in 1991.

N: the number of vessels

MEAN GRT (GRT): average Gross Register Tonnage (in register tons)

% CONV FACT (CF): percentage conversion factor relating GRT and estimated quantity of ballast water discharged

CALC MEAN DIS (CMD): calculated average ballast quantity intended for discharge per vessel per port;  $CMD = GRT \times CF$

CALC TOTAL DIS (CTD): calculated total ballast quantity intended for discharge by all vessels in each port;  $CTD = N \times CMD$

VESSEL TYPE	N	MEAN GRT	% CONV FACT	CALC MEAN DIS	CALC TOTAL DIS
ALL	179	27162	11.1	3015	539685
BULK	30	16190	14.3	2315	69450
CONT	19	17633	*	303*	5757
GC	56	11667	6.2	723	40488
TANK	68	47652	3.0	1430	97240

\* CMD from Shipping Study (see text).

Table 34. Mean gross register tonnage (GRT; in register tons) for vessels carrying acknowledged and unacknowledged ballast bound for St. John's in 1991 (from Canadian Coast Guard (ECAREG) records).

Data are presented (N: number of vessels; SUM: total quantity for all N; MEAN: average quantity per vessel; SD: standard deviation around the MEAN) for all vessels (ALL), bulk carriers (BULK), container carriers (CONT), general cargo carriers (GC) and tankers (TANK).

---

VESSEL TYPE	DATA	ALL	BT	XBT
ALL	N	86	25	56
	SUM	447003	73030	435537
	MEAN	5198	2921	7777
	SD	3860	1983	7293
BULK	N	1	0	1
	SUM	17818	0	17818
	MEAN	17818	0	17818
	SD	0	0	0
CONT	N	27		
	SUM	222732		
	MEAN	8249		
	SD	3513		
GC	N	32	7	18
	SUM	124637	27577	62288
	MEAN	3895	3940	3460
	SD	3008	2659	2868
TANK	N	16	15	1
	SUM	32542	30943	1599
	MEAN	2034	2063	1599
	SD	1058	1087	0

---

Table 35. Estimated quantity of ballast water (in metric tons) discharged (DIS) by all vessels (ALL), bulk carriers (BULK), general cargo carriers (GC) and tankers (TANK) carrying acknowledged ballast to St. John's in 1991.

N: the number of vessels

MEAN GRT (GRT): average Gross Register Tonnage (in register tons)

% CONV FACT (CF): percentage conversion factor relating GRT and estimated quantity of ballast water discharged

CALC MEAN DIS (CMD): calculated average ballast quantity intended for discharge per vessel per port;  $CMD = GRT \times CF$

CALC TOTAL DIS (CTD): calculated total ballast quantity intended for discharge by all vessels in each port;  $CTD = N \times CMD$

---

VESSEL TYPE	N	MEAN GRT	% CONV FACT	CALC MEAN DIS	CALC TOTAL DIS
ALL	25	2921	54.2	1583	39575
BULK	0		62.2	0	0
GC	7	3940	25.9	1020	7140
TANK	15	2063	54.2	1118	16770

---

Table 36. Estimated quantity of ballast water (in metric tons) discharged (DIS) by all vessels (ALL), bulk carriers (BULK), container carriers (CONT), general cargo carriers (GC) and tankers (TANK) carrying unacknowledged ballast to St. John's in 1991.

N: the number of vessels

MEAN GRT (GRT): average Gross Register Tonnage (in register tons)

% CONV FACT (CF): percentage conversion factor relating GRT and estimated quantity of ballast water discharged

CALC MEAN DIS (CMD): calculated average ballast quantity intended for discharge per vessel per port;  $CMD = GRT \times CF$

CALC TOTAL DIS (CTD): calculated total ballast quantity intended for discharge by all vessels in each port;  $CTD = N \times CMD$

---

VESSEL TYPE	N	MEAN GRT	% CONV FACT	CALC MEAN DIS	CALC TOTAL DIS
ALL	56	7777	11.1	863	48328
BULK	1	17818	14.3	2548	2548
CONT	27	8249	*	303*	8181
GC	18	3460	6.2	215	3870
TANK	1	1599	3.0	48	48

---

\* CMD from Shipping Study (see text).

Table 37. Estimated quantity of ballast water (in metric tons) discharged (DIS) by vessels carrying acknowledged (BT) and unacknowledged ballast (XBT) bound for Vancouver in 1991.

N: the number of vessels

MEAN GRT (GRT): average Gross Register Tonnage (in register tons)

% CONV FACT (CF): percentage conversion factor relating GRT and estimated quantity of ballast water discharged

CALC MEAN DIS (CMD): calculated average ballast quantity intended for discharge per vessel per port;  $CMD = GRT \times CF$

CALC TOTAL DIS (CTD): calculated total ballast quantity intended for discharge by all vessels in each port;  $CTD = N \times CMD$

BALLAST CONDITION	N	MEAN GRT	% CONV FACT	CALC MEAN DIS	CALC TOTAL DIS
BT	2805	22216	54.2	12041	33775005
XBT	312	22216	11.1	2466	769392

Table 38. Estimated quantity of ballast water (in metric tons) discharged (DIS) by vessels carrying acknowledged (BT) and unacknowledged ballast (XBT) that visited Prince Rupert in 1991.

N: the number of vessels

MEAN GRT (GRT): average Gross Register Tonnage (in register tons)

% CONV FACT (CF): percentage conversion factor relating GRT and estimated quantity of ballast water discharged

CALC MEAN DIS (CMD): calculated average ballast quantity intended for discharge per vessel per port;  $CMD = GRT \times CF$

CALC TOTAL DIS (CTD): calculated total ballast quantity intended for discharge by all vessels in each port;  $CTD = N \times CMD$

---

BALLAST CONDITION	N	MEAN GRT	% CONV FACT	CALC MEAN DIS	CALC TOTAL DIS
BT	358	27969	54.2	15159	5426922
XBT	40	27969	11.1	3105	124200

---

Table 39. Estimated quantity of ballast water (in metric tons) intended for discharge by all vessels entering the Great Lakes and listed ports.

N: the number of vessels

GRT: average Gross Register Tonnage (in register tons)

DIS: estimated quantity of ballast water discharged by all vessels in each location

PORT	N	GRT	DIS
Great Lakes	427	13182	1395461
Riverport	328	18333	1101878
Halifax	953	25931	2815660
St. John	338	20269	1542505
St. John's	86	5198	87903
Vancouver	3117	22216	34544397
Prince Rupert	398	27969	5551122

Table 40. Estimated quantity of ballast water (in metric tons) carried (BOB: ballast on board) by vessels with acknowledged (BT; i.e. travelling in ballast) and unacknowledged ballast (XBT; i.e. with some combination of cargo and ballast water, or in full cargo and carrying only residual ballast water) to the listed destinations in 1991.

N: the number of vessels

BAL CON: Ballast Condition

MEAN GRT (GRT): average Gross Register Tonnage (in register tons)

% CONV FACT (CF): percentage conversion factor relating GRT and estimated quantity of ballast water discharged

CALC MEAN BOB (CMB): calculated average ballast quantity intended for discharge per vessel per port;  $CMB = GRT \times CF$

CALC TOTAL BOB (CTB): calculated total ballast quantity intended for discharge by all vessels in each port;  $CTB = N \times CMB$

DESTINATION	N	BAL CON	MEAN GRT	% CONV FACT	CALC MEAN BOB	CALC TOTAL BOB
Great Lakes	143	BT	13324	52.1	6942	992706
	284	XBT	13110	13.3	1744	495296
Riverport	82	BT	13095	57.3	7503	615246
	222	XBT	21100	12.1	2553	566766
Halifax	136	BT	16785	57.3	9618	1308048
	796	XBT	17861	12.1	2161	1720156
St. John	145	BT	12760	57.3	7311	1060095
	179	XBT	27162	12.1	3287	588373
St. John's	25	BT	2921	57.3	1674	41850
	56	XBT	7777	12.1	941	52696
Vancouver	2805	BT	22216	57.3	12730	35707650
	312	XBT	22216	12.1	2688	838656
Prince Rupert	358	BT	27969	57.3	16026	5737308
	40	XBT	27969	12.1	3384	135360

Table 41

TOTAL ESTIMATED VOLUMES OF FOREIGN BALLAST WATER  
ARRIVING IN THE GREAT LAKES

	Metric Tons	Gallons
Acknowledged Ballast		
Based upon:	992,706	261,578,000
143 foreign-in-ballast-arrivals		
all commercial ship types included		
 Unacknowledged Ballast	 495,296	 130,510,000
Based upon:		
284 foreign-in-cargo vessels		
all commercial ship types included		
 TOTALS:	 <u>1,488,002</u>	 <u>392,088,000</u>
Volume per month:	124,000	32,674,000
Volume per day:	4077	1,074,000
Volume per hour:	170	44,750
Volume per minute:	3	750

Note: The Great Lakes here includes the ports of the upper St. Laurence River above the entrance to the Seaway at Montreal and all the ports of the Great Lakes; no adjustment was therefore required for the 38 ports additional to the eight ports specifically selected for study.

Table 42

TOTAL ESTIMATED VOLUMES OF FOREIGN BALLAST WATER  
ARRIVING IN CANADIAN COASTAL PORTS

	Metric Tons	Gallons
Acknowledged Ballast		
Based upon:	44,470,197	11,717,896,000
3551 foreign-in-ballast-arrivals		
6 ports		
all commercial ship types included		
Unacknowledged Ballast	3,902,007	1,028,179,000
Based upon:		
1605 foreign-in-cargo vessels		
6 ports		
all commercial ship types included		
Above excludes the following:	4,837,200	1,274,602,000
Approximately 120 different		
Canadian ports that received		
foreign vessels in 1991		
	<u>53,209,404</u>	<u>14,020,677,000</u>
Volume per month:	4,434,117	1,168,390,000
Volume per day:	145,779	38,413,000
Volume per hour:	6,074	1,600,000
Volume per minute:	101	2,661

(\*) Assuming that one-half of these ports (60) each received at least 1% (80,620 MT) of the average volume of the total acknowledged and unacknowledged ballast water at each of the six selected ports (8,062,035 MT)