

REPORT DOCUMENTATION PAGE

Form Approved
OMB No. 0704-0188

Public reporting burden for this collection of information is estimated to average 1 hour per response, including the time for reviewing instructions, searching existing data sources, gathering and maintaining the data needed, and completing and reviewing the collection of information. Send comments regarding this burden estimate or any other aspect of this collection of information, including suggestions for reducing this burden, to Washington Headquarters Services, Directorate for Information Operations and Reports, 1215 Jefferson Davis Highway, Suite 1204, Arlington, VA 22202-4302, and to the Office of Management and Budget, Paperwork Reduction Project (0704-0188), Washington, DC 20503.

1. AGENCY USE ONLY (Leave blank)	2. REPORT DATE 9/4/96	3. REPORT TYPE AND DATES COVERED Final Report--7/20/96--9/4/96
----------------------------------	--------------------------	---

4. TITLE AND SUBTITLE Development of Tactile Stimulators (TACTORS) for Use in Aircraft and Other Naval Vehicles--Final Report	5. FUNDING NUMBERS C N00014-95-C-0197
--	---

6. AUTHOR(S) David Franklin	
--------------------------------	--

7. PERFORMING ORGANIZATION NAME(S) AND ADDRESS(ES) Audiological Engineering Corp 35 Medford Street Somerville, MA 02143	8. PERFORMING ORGANIZATION REPORT NUMBER
--	--

9. SPONSORING/MONITORING AGENCY NAME(S) AND ADDRESS(ES) Office of Naval Research Code 154: R. Dunson Ballston Tower One 800 North Quincy Street Arlington, VA 22217-5660	10. SPONSORING/MONITORING AGENCY REPORT NUMBER
---	--

11. SUPPLEMENTARY NOTES

12a. DISTRIBUTION / AVAILABILITY STATEMENT

DISTRIBUTION STATEMENT B

Approved for public release
Distribution Unlimited

19970513 058

13. ABSTRACT (Maximum 200 words)

DTIC QUALITY INSPECTED 3

14. SUBJECT TERMS	15. NUMBER OF PAGES
	16. PRICE CODE

17. SECURITY CLASSIFICATION OF REPORT	18. SECURITY CLASSIFICATION OF THIS PAGE	19. SECURITY CLASSIFICATION OF ABSTRACT	20. LIMITATION OF ABSTRACT
---------------------------------------	--	---	----------------------------

DISCLAIMER NOTICE

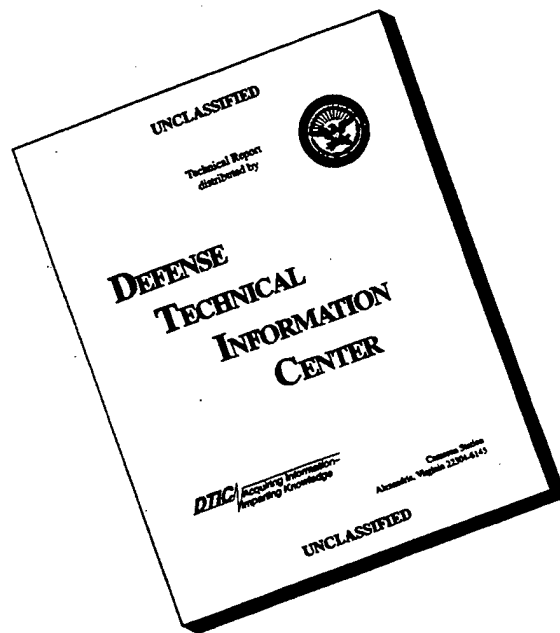

THIS DOCUMENT IS BEST QUALITY AVAILABLE. THE COPY FURNISHED TO DTIC CONTAINED A SIGNIFICANT NUMBER OF PAGES WHICH DO NOT REPRODUCE LEGIBLY.

DEVELOPMENT OF TACTILE STIMULATORS (TACTORS FOR USE IN AIRCRAFT
AND OTHER NAVAL VEHICLES

DATED AUGUST 1996

CONTRACT # N00014-95-C-0197

FINAL REPORT

AUDIOLOGICAL ENGINEERING CORPORATION (AEC)
35 MEDFORD STREET
SOMERVILLE, MA 02143

DTIC QUALITY INSPECTED 3

INDEX

INTRODUCTION-----1
PERSONNEL FROM AUDIOLOGICAL ENGINEERING-----2
MEETINGS AND PHONE CONFERENCES-----2
HARDWARE AND DOCUMENTATION DELIVERED-----3
PART I-PARTICIPATION IN DEVELOPMENT OF
PROGRAM STANDARDS-----5
PART II-PARTICIPATION IN DEVELOPMENT OF
AUXILIARY HARDWARE-----5
PART III- DEVELOPMENT AND EVALUATION OF NEW TACTORS-----7

FIGURES

FIGURES 1 THROUGH 3- PHOTOGRAPHS OF INTERFACE UNIT-----6
FIGURES 4 AND 5- HOUSING FOR INERTIAL TACTORS-----15

APPENDICES

APPENDIX A. PROGRAM STANDARDS FOR SKIN IMPEDANCE
APPENDIX B. SCHEMATICS AND SPECIFICATIONS FOR INTERFACE UNIT

INTRODUCTION This final report includes work done from June 1995 through September 1996. The period of June through August 1995 is prior to the initiation of actual funding which began in September 1995. The reason for this, as explained in Progress Report #1 dated June/Sept 1995, is that early meetings and requirements of the program led all potential contractors to attend a series of meetings at NAMRL and elsewhere and, in some cases, to provide materials and consultative services to members of the NAMRL Staff and their consultants, Drs. Roger Cholewiak and Jan Weisenberger. The bulk of the materials presented below reflect hardware developments and services done during and after September 1995.

The major focus of our work during this first phase of the program has been in three areas: (1) Participation in development of program standards; (2) Participation in development of auxiliary hardware used for tactor evaluations; and (3) Development and evaluation of new Tactors types. The materials presented here are organized according to these three categories listed as **PART I**, **PART II**, and **PART III**, respectively. The initial pages provide a list of all participating personnel from Audiological Engineering, their roles and dates of involvement, a list of all meetings and phone conferences, and a list of all hardware and documentation delivered during the program including the final tactor deliverables spelled out in the contract.

PERSONNEL FROM AUDIOLOGICAL ENGINEERING CORP AND CONTRACTORS

<u>NAME</u>	<u>ROLE IN PROJECT</u>	<u>DATES OF INVOLVEMENT</u>
DAVID FRANKLIN	PRINCIPAL INVESTIGATOR	JUNE 95-SEPT 96
MICHAEL WOLLOWITZ	MECHANICAL ENGINEER	JUNE 95-SEPT 96
LORETTA FRANKLIN	TECHNICAL ANALYST	JUNE 95-SEPT 96
AARON KNEISS	ELECTRONIC ENGINEER	SEPT 95-AUG 96
NATHANIEL DURLACH	CONSULTANT	JUNE 95-JAN 96
JAMES LACKNER	CONTRACTOR	SEPT 95-AUG 96
PAUL DIZIO	CONTRACTOR	SEPT 95-AUG 96
ROBERT MORIARITY	TECHNICIAN	SEPT 95-JAN 96
MARIO MOGIANESI	TECHNICIAN	FEB 96-AUG 96

MEETINGS AND PHONE CONFERENCES INVOLVING AEC

<u>PERSONNEL FROM AEC</u>	<u>LOCATION</u>	<u>DATE</u>	<u>MAIN TOPIC</u>
D. FRANKLIN M. WOLLOWITZ	NAMRL	JUNE 95	OVERVIEW/PLANNING
D. FRANKLIN M. WOLLOWITZ N. DURLACH J. LACKNER P. DIZIO	GREYBIEL LAB	JULY 95	PLANNING AND REVIEW OF FACILITIES
ALL	AEC	JULY 95	VISIT/CHOLEWIAK
ALL	AEC	AUG 95	VISIT/WEISENBERGER
D. FRANKLIN	PHONE/NAMRL	SEPT 95	INTERM DELIVERY OF EQUIPMENT
FRANKLIN WOLLOWITZ	PHONE/GREYBIEL	OCT 95	TASK DEFINITION
ALL	AEC	NOV 95	VISIT/JARMUL
FRANKLIN	PHONE/NAMRL	DEC 95	MCGRATH NEW DESIGN
FRANKLIN	PHONE/NAMRL	DEC 95	MCGRATH TRIP PLANNING
WOLLOWITZ	PHONE/NAMRL	DEC 95	HARDWARE DESIGN ISSUE
FRANKLIN	PHONE/NAMRL	JAN 96	FINALIZE DESIGN
FRANKLIN WOLLOWITZ	GREYBIEL	JAN 96	EXPERIMENTAL DESIGN DEFINITIONS

MEETINGS AND PHONE CONFERENCES INVOLVING AEC (continued)

<u>PERSONNEL FROM AEC</u>	<u>LOCATION</u>	<u>DATE</u>	<u>MAIN TOPIC</u>
WOLLOWITZ	NAMRL	FEB 96	DELIVERY/ EXPERIMENT
FRANKLIN	PHONE/NAMRL	APRIL 96	DISCUSSIONS RE: NASA EXPERIMENTS
FRANKLIN	PHONE/NAMRL	MAY 96	DISCUSSIONS RE: NASA EQUIPMENT
FRANKLIN	PHONE/NASA	JUNE 96	DISCUSS EXPERIMENT
FRANKLIN	PHONE/NAMRL	JULY 96	DISCUSS FINAL DELIVERABLES

HARDWARE AND DOCUMENTATION DELIVERED BY AEC DURING PROGRAM

JUNE 1995---SUPPLIED TWELVE V1220 TACTORS, CONNECTION CORDS, DEVICE SPECIFICATIONS, MEASUREMENT SPECIFICATIONS AND ASSOCIATED OTHER DOCUMENTATION TO DR ROGER CHOLEWIAK FOR CONSTRUCTION OF A STANDARD EXCURSION MEASUREMENT DEVICE. DELIVERABLES ALSO INCLUDED 25 KNOWLES ACCELEROMETERS AND SPECIFICATIONS.

JUNE 1995---SUPPLIED FOURTEEN V1220 TACTORS AND TWO COMPLETE WIRING HARNESSSES (FROM TACTAID VII WEARABLE TACTILE AID SYSTEM) TO NAMRL FOR TESTING PURPOSES.

JULY 1995---DELIVERED SIX V1220 TACTORS, WIRING CORDS AND DOCUMENTATION TO GREYBIEL LABORATORIES FOR STUDIES.

SEPT 1995---SUPPLIED COMPLETE TACTAID VII (INCLUDING DRIVER ELECTRONICS, DOCUMENTATION AND TACTOR ARRAY) TO NAMRL.

FEB 1996---DELIVERED EIGHT "TYPE II" VOICE-COIL TACTORS; EIGHT V1220 VARIABLE RELUCTANCE TACTORS; AND A "UNIVERSAL INTERFACE DRIVER SUITE" AND ASSOCIATED DOCUMENTATION, ALL TO NAMRL

MAR 1996---DELIVERED TWO "TYPE III" WIDEBAND VARIABLE RELUCTANCE TACTORS TO NAMRL.

APRIL 1996--DELIVERED TWO "TYPE III" WIDEBAND TACTORS AND A COMPLETE TACTAID VII (INCLUDING DRIVING ELECTRONICS, TACTORS, HARNESS AND DOCUMENTATION) TO DR CHOLEWIAK FOR HIS WORK AT NASA

HARDWARE AND DOCUMENTATION DELIVERED BY AEC DURING PROGRAM (cont)

MAY 1996---DELIVERED A TACTAID VII (COMPLETE PACKAGE AS ABOVE) TO COMMANDER RUPPERT FOR DEMONSTRATION PURPOSES.

JUNE 1996---DELIVERED TWO COMPLETE TACTAID VII HARNESSSES, CABLE ASSEMBLIES AND FOURTEEN V1242 (42 OHM VERSIONS OF THE V1220 TACTORS) TO DR ROGER CHOLEWIAK AT NASA FOR HIS FURTHER EXPERIMENTS.

SEPT 1996---DELIVERED 50 FINAL TACTORS, EIGHTEEN "TYPE IV" WIDEBAND-HIGH POWER VARIABLE RELUCTANCE UNITS; AND THIRTY-TWO V1242 42 VARIABLE RELUCTANCE ELEMENTS FOR FINAL EXPERIMENTAL PURPOSES TO NAMRL.

PART I- PARTICIPATION IN DEVELOPMENT OF PROGRAM STANDARDS

On June 29, 1995, Commander Angus Ruppert assembled all program participants for an initial meeting at NAMRL. During the meeting it became clear from both the language and specific sensory criteria being used by the various participants that vast differences in perceived design goals existed, depending on the historical disciplines of the different groups. After some lengthy discussion it was decided that Dr. Roger Cholewiak would assemble and distribute literature which provided guidelines for design, and assemble specific measurement "standards" that would enable common measurement techniques among all the participating groups. In particular, an "artificial skin" or "bench mark" model was to be defined that provided a reasonably accurate and consistent mechanical impedance for loading all tactors. The essence of the model was drawn from an article on skin impedances published by two of the participants, Dr. Cholewiak and Michael Wollowitz, which was based in part on an earlier work by two other participants, David and Loretta Franklin.

At the request of Drs. Cholewiak and Weisenberger, Audiological Engineering corporation subsequently provided sufficient standard skin tactors (Model V1242 units), a variable reluctance tactor type used with a commercially available wearable tactile aid used by deaf individuals, a complete set of dynamic response characteristics (temporal and spectral) for the design, and a type of accelerometer (Knowles BU1771) in sufficient quantity to enable Dr Cholewiak to construct complete calibrated measurement systems for each participant group. While it is not possible to include the hardware in this final report, the supporting literature developed by Dr Cholewiak is include herein as **ENCLOSURE A**.

A second concern raised at the meeting by D. Franklin was that there existed no formal safety requirements for tactors to be used in field evaluations when said evaluations were done in aircraft of various types, as opposed to being done in simulated settings. Mr. Franklin expressed this concern in view of the statement that such "real world" evaluations were intended. This topic was shelved on the basis of several statements made by Naval Personnel to the effect that any such evaluations would be subject to safety considerations enforced by standard experimental flight regulations.

PART II- PARTICIPATION IN DEVELOPMENT OF AUXILIARY HARDWARE

It became evident during the latter part of October that the devices being supplied to NAMRL varied in driving requirements, and that the apriori driving suite developed by NAMRL for this program could not drive all types. Accordingly, and in conjunction with the NAMRL staff, Audiological Engineering designed and built a

tactor driving unit that could be interfaced with the computer based test-bed assembled at NAMRL. This unit was delivered and tested at NAMRL in February 1996. Three photographs of the system are included as Figures 1 through 3, taken during the February evaluation at NAMRL. The schematics and specifications for the interface driver suite are included as Appendix B.

COUPLER

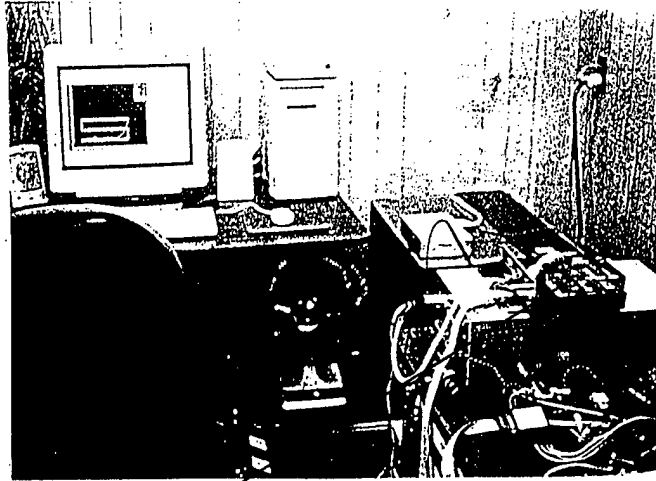

ELECTRONICS CASE

ELECTRONICS
AND CABLE

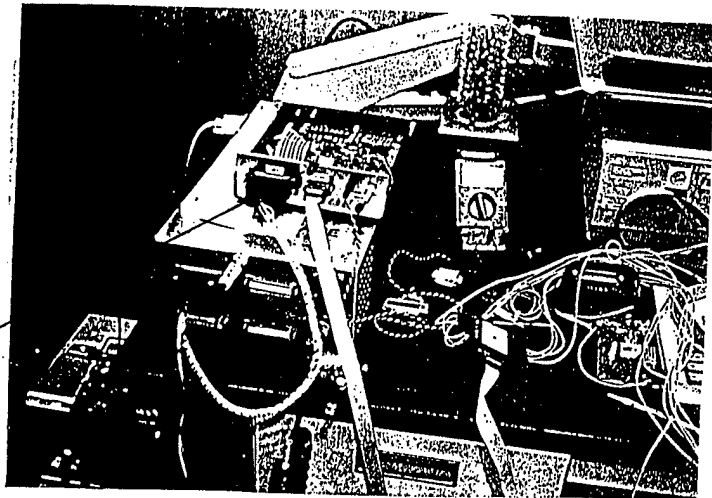

PART III- DEVELOPMENT AND EVALUATION OF NEW TACTORS.

The initial design planning for our aspect of this program began in June 1995 with meetings held at Audiological Engineering Corporation and Greybiel Laboratories. During these meetings it was decided that two types of tactor technologies should receive the most attention, variable reluctance designs and voice coil designs. The advantage of the former is that they have been the prime type used in the industry for the past fifteen years, and their design procedures are well understood. Also, by their nature, they tend to be cheaper and more rugged than any other type currently under development. On the other hand, voice coil types are inherently more efficient, but suffer from greater expense unless manufactured in very large quantities (as in conventional loudspeakers) and tend to be less rugged particularly since the voice coil structure itself must deliver the mechanical forces to the skin. This results in issues regarding centering the voice coil within the voice gap and preventing it from self destructing due to angular forces and from impact forces. A third type, bimorph excitation was discussed as an alternative, but it was decided to not experiment with these until later in the program.

VIBRATION TEST-BED The first defined task was to construct a vibration tester which enabled destructive testing of the models. This task was accomplished within the first month of the program and consisted of a high power loudspeaker driven by a computer controlled audio-amplifier system capable of delivering up to 50 watts to the test tactor. The tactors were mounted on a small platform built into the speaker cone. A Knowles BU1772 accelerometer was mounted on the same platform and its output instrumented to provide test data on acceleration, velocity and displacement of applied test signals. Test signals consist of sinusoidal voltages generated by the computer software with programmed amplitudes and frequency across the test band of 10 Hz through 1000 Hz. This system was used throughout the program for samples of all tactors developed.

VOICE COIL DESIGNS The initial tactor type addressed were voice coil designs. A magnetic structure and voice coil from a standard small speaker (Shokai T272C 24 mm loudspeaker) was used as a test model wherein the existing cone suspension was replaced with a specially designed thin metal diaphragm such that the weight of the magnetic structure taken together with the spring constant of the new suspension had a nominal resonance of 600 Hz. This assembly was then entirely enclosed within a housing thus forming an "inertial transducer" type similar to the classical skin excitors used in the field, except that the usual variable reluctance driver was replaced with the aforesaid voice coil excitor. This model was evaluated both analytically utilizing the transducer-skin mechanical model shown in enclosure A, and experimentally using a skin simulation similar to that described by Dr. Cholewiak. The

results from both studies (theoretical and experimental) showed good agreement, and thus the modeling system was taken to be valid for the remainder of the work.

SELF EXCITING TACTORS At this juncture in our work, a report from Dr. Brad McGrath regarding testing at NAMRL, including some field testing in a rotary wing aircraft, indicated that there was some misunderstanding on our part as to the intended method of driving the tactors. The essence of this conversation and a following meeting relating to the tactor interface being used for field testing in stationary and rotary wing aircraft, indicated that the actual flight equipment utilizes a switched monopolar pulse for applying power to the tactors, not a sinusoidal oscillator as had been done in the laboratory setting. In view of this, it was decided to build an oscillator and driver into the existing V1220 housings which would enable compatibility with the field equipment. Given that Dr McGrath concurred on this solution, a portion of our effort was switched into this development.

The essential idea in the design was to incorporate an oscillator circuit and miniature driver into the V1220 housing. This was intended as a demonstration of the technique, but that it might not, in the final version, be based on the existing V1220 type, but on some as yet undetermined new design that could be either variable reluctance or voice coil. In as much as a very small space had to accommodate the entire circuit, an integrated "H" bridge driver was used which does not require coupling capacitors and the output coil (and hence the entire vibrating mechanical load) was incorporated into the circuit as a "tank". Because we wished to supply the units quickly, all parts were hand soldered without a circuit board. Twenty units were built, but in the process of ultrasonic welding (which is our normal method of sealing these devices) only 6 survived the process. In large part we believe this was due to the absence of a printed circuit board although it was felt that further analysis of the failure mode was required.

Unfortunately it was found that variations in main resonance of the units occurred and excessive parasitic oscillations developed when they were loaded onto the body which caused erratic and unpredictable behavior. Analysis of this effect showed that the problem lay in using the coil and mechanical load as part of the oscillator circuit. The small changes in resonance frequency that occurred during mechanical loading resulted in the observed instabilities.

Experiments on a few units showed that if an independently tuned oscillator was included in the package the instabilities vanished. Accordingly the first design was scrapped and a new design generated. The analysis of the failures that occurred during

welding was continued and it appeared to be more a function of poor mounting of components than the ultrasonic welding per-se. This is fortunate since the welding is necessary to obtain a reliable water-proof seal.

CONTINUED VOICE COIL WORK A design for a suspension spring for the previously mentioned voice-coil type was completed and a series of spring types manufactured that had identical spring characteristics, but utilized different basic geometries. The issue was to determine which type resulted in the most easily manufactured form and provided the best lateral stability against acceleration forces not normal to the plane of the excursion as might be encountered in actual use. A set of design criteria was established based on measurements and data appearing in the literature. One major criterion related to top-end resonance of the structure (approximately 600Hz) which, taken in conjunction with skin sensitivity and mechanical excursion according to the characteristics of a damped mechanical system, would provide essentially flat perceptual responses over the range below 100 Hz up to 600 Hz. The other major criterion related to excitation levels required in the use context and, in absence of clear guidelines, are being taken as 40 db above threshold as measured on the forearm at 250 Hz. While this excitation level is about 10 db above that usually assumed for this kind of signaling use, it is felt it is a wise choice in view of uncertainties regarding specifics of application.

Further work in this area included the evaluation of driving level potential of samples of available samarium-cobalt speaker assemblies from a number of manufacturers. While we recognize that the self-exciting type may be best in these devices, as well as in the V1220 types, we are not yet considering their integration into this design beyond leaving sufficient space in the housing to incorporate the necessary electronics.

CONTINUED WORK ON SELF-EXCITING TACTORS As discussed previously above, a second generation design was completed for the self-exciting tactors still based on the V1220 excitor design, was completed. A test jig for driving them in pairs was constructed to enable life testing and comparison of characteristics of the devices with time as a function of driving conditions. In view of the discussion with Dr. McGrath, indicating that the initial units would be used in the simulator, we made no attempt to seal the prototypes against environmental stresses (mainly sweat and other sources of moisture). The concept was that if the design was found to be adequate from an intensity and geometry point of view, the next generation devices would be constructed using more suitable materials and techniques for field applications. As it happened, there was no further generation developed of this type, so if program requirements suggest it, further development of this tactor

type would progress from this stopping point.

CONTINUED DESIGNS of WIDEBAND TACTORS BASED ON VOICE COIL TECHNOLOGY- Having determined suspension characteristics (geometry and spring constants) as applied to a selection of voice coil types, two alternate modes of realizing the desired response characteristics were evaluated; one which yields an "inertial" mode of operation similar to that used in narrow-band tactors such as the V1220/V1242 series; the second which provides a modified "contact" mode of excitation. Both of these designs delete the need for a spring as such, replacing it with closed-cell foam to support the voice coil driver in a housing, or using an open-cell arrangement of foam to act as a mechanical transducer between the voice-coil driver and the skin. It was found that either mode appeared to provide a more than adequate excitation level and the issue of which is better depends on the mode of application. Sources for alternate voice coil assemblies were located and samples of 5 different types were ordered and evaluated. The methods tested worked with all five types. It was clear that the amount of damping required could be obtained by commercially available foam types, although some loss in efficiency was encountered, particularly as a function of increasing force level requirements.

The completion of this phase of our work consisted mainly of a survey of available small format voice coil type drivers which could be configured into either the inertial mode or direct contact drive mode, the latter either with or without an intervening "mechanical matching transformer" made up of open-cell foam. In all we examined over 50 small cone speakers types of which approximately 20 appeared to have suitable characteristics. As listed above in deliverables, samples of three different types typical of this technology were delivered to NAMRL or to the NASA sites.

As a further aspect of this work we extended the skin transducer model to examine the differences between resonant (narrow band excitations) and wideband excitations. The model suggests that for the wideband mode of use that the direct contact method, when practical, yields improved efficiency at the expense of perhaps lower reliability because of the danger that the voice coil driver may be inadvertently damaged when it pressed against the skin.

At the advice of one of our suppliers, we extended our evaluations to include what in the industry are called "buzzer" mechanisms. In essence these devices are electronic relays that can be driven by squarewaves and generate significant excursion similar to voice coil mechanisms, but with inherently greater ruggedness. These devices were supplied to us by Primo Microphone Corporation. At

least for the samples they had available, we were not impressed with performance either for narrow band or wide band applications, and we quickly abandoned this type for serious consideration. A third type of mechanism recently developed for use in pager systems were considered, but we were unable to obtain samples of them.

CHARACTERISTICS OF FIRST GENERATION VOICE COIL UNITS DELIVERED TO NAMRL The voice coil drivers delivered to NAMRL were constructed around standard 36 mm Panasonic units (part # P9604-ND) utilizing an 8 gram magnet, 8 ohm voice coil, frequency range of 325 to 3500 Hz and with power rating of 200 milliwatts. The micro-speaker was modified by reducing its spring constant (to lower it to approximately 600 Hz) and by attaching a contact button measuring .5" diameter and .25" deep to its cone. The speakers were mounted in a vented metal housing (to adjust the spring constant further) and the assembly provided with an appropriate cord/connector set. What resulted from this design effort was a wideband tactor type able to excite the sensory system from below 50 Hz to above 500 Hz. After testing, 10 such units were manufactured of which 8 were delivered to NAMRL. The remaining 2 units were retained at our laboratory as samples for use later in the program. No attempt was made at this time to utilize the foam suspension that had been earlier experimented with. This units were specified as not being suitable for use in aircraft since materials used in construction were not evaluated in terms of on-board safety requirements.

DESIGN OF SECOND GENERATION VOICE COIL TACTORS The next effort was to implement the voice coil units in an inertial package format. To this end, two data collections were carried out: The first designed to refine the inertial model by measuring the detailed performance characteristics of the V1220 tactor type as loaded by Dr. Cholewiak's mechanical load; The second to machine an experimental housing and evaluate the model using the same voice-coil drivers as in the contact voice-coil units provided to NAMRL.

At this point in our work a change in direction was indicated, away from voice coil designs, and towards inertial types, based on some discussions that took place between our staff, the NAMRL staff, and the staff at Greybiel Laboratories. The essential point made was that, as discussed in Report #6 and above, that the inertial type of transducer design was easier to use and more reliable given the mode of attachment. In view of this, it was decided to attempt to construct a wideband version of an inertial transducer utilizing a variable reluctance speaker design, instead of the voice coil type used in the previously delivered prototype unit. In view of the fact that for most of the contemplated applications (but not all) the need for high efficiency is less than the need for reliability, ruggedness and (a new requirement) low radiated sound.

This latter consideration is another factor favoring the "inertial"

approach, since inherently these designs radiate less sound than do contact types. In view of these new considerations, a commercially available driver type (TS40-S-8-B3A-FUJI) was modified appropriately and totally enclosed in the previously machined plastic housing, the model modified to take into account the differences between the FUJI mechanical characteristics and that of the previously used Panasonic voice coil unit, and several wideband prototypes constructed. The resulting tactor measures .5 inches in height, 1.5 inches in diameter, weighs approximately 30 grams and has a nominal 8 ohm coil. The maximum rated drive level is 800 milliwatts (more than 4 times higher than the Panasonic unit) and adequate drive levels are obtained at approximately 250 milliwatts from below 100 Hz to above 300 Hz.

At this point we were notified by a FAX message from NAMRL that a comparative evaluation of all tactors developed by all contractors to this point was to be held at NAMRL early in March of 1996. The message indicated that each contractor should be prepared to present and explain the operation of their devices. Dr. McGrath indicated during the phone conversation that the frequent contact we had maintained with NAMRL, including the early delivery of prototype units and the interface driver complex, made it unnecessary for us to attend. As a consequence of this discussion, however, samples of the new variable reluctance tactor types were delivered for our participation in the study. This was somewhat in advance of when we had expected to deliver the units hence only two of this new type (which we called "Type III") were delivered, wherein we had intended to manufacture 10 and deliver 8 as was the case with the earlier "Type II" voice coil designs.

A further related conference with Dr. Cholewiak indicated some new pertinent information as well: viz., that early studies and review of proposed applications suggested that more than one tactor type was going to be required, some of which would be very high output devices, some of which would have premiums placed on efficiency and small size, and several other characteristics that were not as yet well defined. In view of this, it was suggested that we consider our design types in the context of, in particular, high stimulation levels, low sound emission (which we had previously addressed) and lower frequency signals than those we had been considering (i.e., well below 100 Hz). To some extent, Dr. Cholewiak suggested, we should consider the "motor type" as a model for performance which we had not, up to this point, done so.

At the same time Dr. Cholewiak notified us of an extension of the program to include cooperation with related work taking place at NASA (Johnson Space Center) in which he would be participating. At his request we provided him 2 additional samples of our "Type III" variable reluctance wideband transducers, a complete Tactaid VII package including 7 V1242 tactors and related documentation. As

stated above, these equipments were later supplemented by additional wiring harnesses and another complete Tactaid VII package for his work at NASA and subsequent use by Commander Ruppert.

FURTHER FINDINGS ON WIDEBAND TACTORS OF TWO TYPES; INERTIAL AND DIRECT CONTACT UTILIZING VARIABLE RELUCTANCE DRIVERS For these evaluations either one or another of two commercially available variable reluctance driver elements were used: either TS40-R-8-B3A (Fuji); or TS30-R-8-B3A (Fuji), the major difference between the two types being the overall size (40 mm or 30 mm in diameter) and the nominal peak resonance (higher in the smaller type). The variations looked at consisted of: (1) either inertial or direct contact; (2) using more than one driver element to construct the samples. The major findings were:

- 1/ The inertial types are significantly more rugged and reliable in terms of being sure that contact forces do not prevent them from delivering adequate stimulation levels.
- 2/ The contact types are inherently more efficient and enable total weight to be less by at least a factor between 5 or 10 times.
- 3/ The inertial types are significantly better in terms of not radiating undesired sound.
- 4/ Radiated sound from contact types can be improved if two elements are used to realize them, where each driver is driven 180 degrees out of phase with the other. The effectiveness of this approach decreases as the driving frequency is increased, becoming not very useful much above about 800 Hz. However, since the maximum frequency used in these applications is unlikely to be above 500 Hz, this is not a serious problem.
- 5/ Using two elements has the advantage of allowing a flatter output response as a function of frequency (stagger tuning) for either configuration (contact or inertial), but is more effective for inertial type designs.
- 6/ The general efficiency of the driver is improved if higher coil impedances can be used. This is often true for variable reluctance drivers because of the relatively poor magnetic efficiency of the circuit type. The smaller wire used at higher impedances results in more coil windings being close to the central iron in the design. The implication is that somewhat higher driving voltages for the tactors results in better efficiencies. Desired levels are probably in the 10 to 20 volt region for these kinds of applications although voltages of about 7 to 8 are probably more appropriate for mobile (battery) situations. This circumstance also suggests that either "H" bridge or PWM drivers are appropriate for the output power stage used with these devices.

DESIGN AND DELIVERY OF HIGH LEVEL, WIDEBAND, VARIABLE RELUCTANCE DRIVERS In view of the discussions with Drs. Cholewiak and McGrath, a final electromagnetic design was obtained for the variable reluctance tactors that reached the desired level of efficiency and perceptual level taking into account operation at very low frequencies. It should be understood that this device, while similar in over-all concept to the previous type III tactor, differs in details which ultimately led to somewhat different packaging characteristics. In particular, the fact that it was designed to operate down to very low frequencies (less than 10 Hz in the final design) it sacrificed some capability at frequencies much above 250 Hz. This result tends to underline the earlier observation that different applications require different kinds of devices. Our implementation of this last program design utilized a modified version of the FUJI stainless-steel variable reluctance drivers discussed in the previously and has the important virtues of extreme ruggedness, potential ability to operate in adverse environments, including underwater, radiates vanishingly small sound levels, and provides strong excitation levels at modest driver power levels (typically less than 200 MW) over the range 10 Hz to about 200 Hz. 18 of this "Type IV" design have been delivered to NAMRL prior to submission of this report and, along with 32 additional V1242 units, meet the requirements of hardware deliverables for this phase of our work.

FINAL TACTOR HOUSING DESIGN The last phase of this work which was carried out simultaneously with development of the high level transducer just described, was the design of a housing which could accommodate all of our variable reluctance types including, if it became necessary to produce such a unit type, the self exciting variety. The important considerations we addressed in designing the housing were: (1) Assuring that the high power versions are configured to supply low frequency outputs at or exceeding the levels obtained with vibrating motors; (2) Developing a case characteristic that reduces radiated sound (spectral signature) to the lowest possible level, taking into account that the design type will ultimately be used underwater; (3) Begin to address the underwater application mode in terms of waterproofing and developing a means to enable the units to operate under pressures characteristic of such uses; and (4) attempt to obtain a design which enables all of our contemplated "inertial" designs to be accommodated by the one design with only a minor amount of modification. It was taken as given that any direct contact type, should that design be desirable (which we doubt), an additional case would be designed in a later phase of the program. In as much as no specific specifications have yet been adopted for any of these requirements, a "best effort" criteria was applied.

A set of working drawings were completed that specify all requirements for a water-proof variable reluctance housing and a

sample of the design was produced using stereolithography. After evaluating the essential design 20 cases were produced utilizing a machining process that deleted the non-essential aspects of the design (i.e., the stress-relief for the cord, the mounting mechanism and the special treatment of the sealing surfaces to enable ultrasonic welding. Figures 4 and 5 following show the appearance of the final case design. At present we have not prepared an actual mold documentation package, but the data base for such a design is in our files.

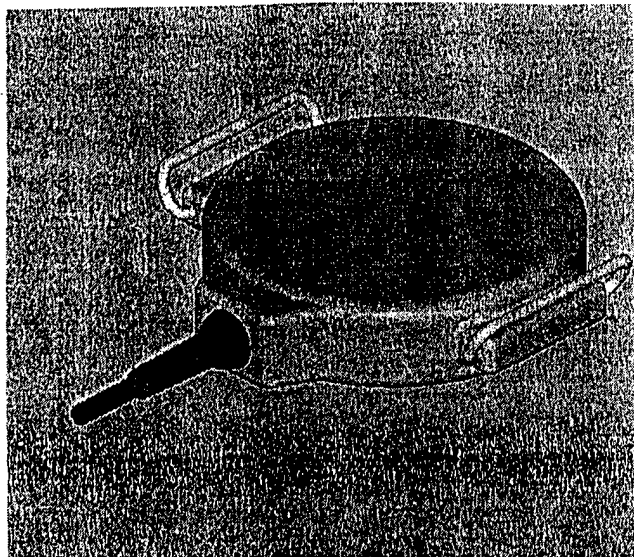
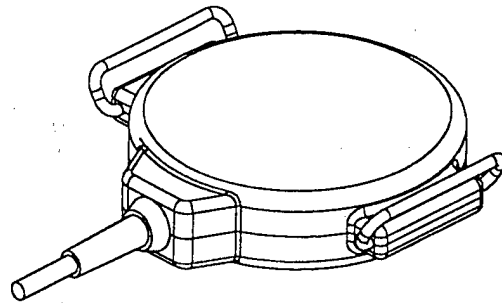

The case design is such that there are two distinctly different mounting capabilities for the transducers being used: one which enables the mass of the transducer itself to be suspended using the stainless steel membrane as the mounting surface; a second mode in which the transducer housing itself is mounted rigidly in the case, and a separate mass is suspended on the face of the membrane. The essential difference in performance between the two designs is that the former configuration has a lower "Q" and hence a wider band-width of response. This provides a somewhat lower level of excitation, but provides the possibility of using changing frequency as an encoding method. The latter method results in a much narrower range of usable frequency for excitation (which may be adjusted by changing the mass used as a load), but provides a significantly higher excitation amplitude. The flexibility to attain either configuration was obtained by utilizing an extra "platform" part that will be glued into the interior in the case of the former design, and deleted in the case of the latter format.

Submitted in partial fulfillment of contract requirements.

David Franklin Principal Investigator

ONR / Naval Aeromedical Research Laboratory

Tactile Advanced Technology Demonstration Program

Tactor Development Benchmark

OVERVIEW

This package was compiled to aid development and comparisons of vibrotactile stimulators being designed by the several groups working under the Naval Aeromedical Research Laboratory (NAMRL) Tactile Advanced Technology Demonstration (ATD) Program funded by the Office of Naval Research (ONR). The need for this package was identified at the *Tactile Transducer Workshop* held at NAMRL in Pensacola FL on June 28, 1995. It was deemed important to have a standard benchmark against which each of the developers could compare the output of their unique device. With the resulting data, it will be possible to compare more readily these systems in terms of the sensation felt by the human participant. The tactile transducer hardware, accelerometers, suggested circuits, and calibration curves were provided by David Franklin at Audiological Engineering Corporation. The enclosed hardware system was assembled and calibrated by Roger Cholewiak at Princeton University, while the psychophysical protocols, testing, analysis, and reporting recommendations were developed by Roger Cholewiak, James Craig at Indiana University and Janet Weisenberger at Ohio State University.

DO NOT REMOVE TRANSDUCER FROM THE FOAM BLOCK - IT IS ATTACHED WITH HEAT GLUE AND IS INTENDED TO BE USED AS MOUNTED!!

CONTRIBUTORS:

David Franklin (df) Audiological Engineering Corp 35 Medford Street Somerville, MA 02143	Phone: (617) 623-5562 FAX: (617) 666-8430
Roger W. Cholewiak (rwc) Princeton University Cutaneous Communication Lab Department of Psychology-Green Hall Princeton, NJ 08544-1010	Phone: (609) 258-5277 FAX: (609) 258-1113 e-mail: rcholewi@princeton.edu
James C. Craig (jcc) Indiana University Department of Psychology Bloomington, IN 47405-1301	Phone: (812) 855-3926 FAX: (812) 855-4691 e-mail: craigj@ucs.indiana.edu
Janet M. Weisenberger (jmw) The Ohio State University Speech and Hearing Science 110 Pressey Hall, 1070 Carmack Road Columbus, OH 43210-1002	Phone: (614) 292-1281 FAX: (614) 292-7504 e-mail: jan+@osu.edu

PACKAGE CONTENTS:

- List Of Enclosed Hardware2
- Description And Instructions For Use Of System Hardware (df).....2
- Description And Characteristics Of Knowles® Accelerometer (df/ rwc).....3
- Psychophysical Testing Protocols, Data Collection & Reporting (rwc/ jcc/ jmw)4

rwc - September 5, 1995

AUDIOLOGICAL ENGINEERING CORP.
35 Medford Street
Somerville, MA 02143

950802-Calibration of Audiological Engineering Corp V1242 Vibrators delivered to rwc 7/21/95

- Exact 128 function generator set to 250 Hz, continuous, 2.12 V_{rms} (6.0 V p-t-p)
- Knowles accelerometer with 2-wire circuit as shown in specification sheets
- Accelerometer attached to V1242 centered on circular mold pattern on V1242 case
- Vibrator/ accelerometer resting on latex foam loaded with a small (175 gm) sandbag to produce force described in text
- K Accel = Knowles Accelerometer output in mV_{rms} to 2.12 V_{rms} (6.0 V p-t-p) input - 3 readings
- P Accel = Knowles Accelerometer output in mV_{rms} to produce c. 20 μ peak
(measured with PCB 309A (s/n 2144) = 18 mV_{rms}, mounted on Knowles Accelerometers)

Vibrator #	K Accel ₁ (loaded)	K Accel ₂ (loaded)	K Accel ₃ (loaded)	P Accel (loaded)	Test Site	Resonant Freq (unloaded)
1	34	37	40	.022	Craig	275
2	30	31	29	.026	Beebe	288
3	31	32	29	.025	Churchill	290
4	28	29	26	.023	Weisenberger	283
5	21	21	19	.026	Ensign	295
6	29	29	26	.026	Franklin	293
7	35	37	33	.026	Johnson	288
8	26	26	23	.026	Langberg	298
9	20	20	18	.023	Jarmul	297
10	26	26	24	.027	Weed	298
11	21	21	19	.026	Wells	298
12	21	22	22	.023	Cholewiak	300

#12= about 2.45 V_{rms} (6.93 V p-t-p) input for standard output

Dr. David J. Beebe
Department of Biomedical Engineering
Louisiana Tech University
711 S. Vienna Street
Ruston, LA 71270

Dr. James C. Craig
Indiana University
Department of Psychology
Bloomington, IN 47405-1301

Dr. David L. Wells
Sarcos Research Corporation
360 Wakara Way
Salt Lake City, UT 84108

Mr. A. David Johnson, President
TiNi Alloy Company
1621 Neptune Drive
San Leandro, CA 94577

Dr. Janet M. Weisenberger
The Ohio State University
Speech and Hearing Science
110 Pressey Hall, 1070 Carmack Road
Columbus, OH 43210-1002

Dr. Edward H. Jarmul
NAVAEROMEDRSCLAB
51 Hovey Road, CODE 22-ATD
Pensacola, FL 32508-1046

Mr. David Franklin
Research Director and President
Audiological Engineering Corporation
5 Medford Street
Somerville, MA 02143

Mr. Thomas H. Ensign, President
Engineering Acoustics, Inc
1490 Gene Street
Winter Park, FL 32789

Dr. Russel J. Churchill
American Research Corporation of Virginia
P. O. Box 3406
Radford, VA 24143-3406

Dr. Edwin Langberg
Sensor Electronics, Inc.
56 Bridge Road
Medford, NJ 08055-4205

Mr. Herman R. Weed
The Ohio State University
Department of Electrical Engineering
205 Drees Laboratory, 2015 Neil Avenue
Columbus, OH 43210-1272

Dr. Roger W. Cholewiak
Department of Psychology - Green Hall
Princeton University
Princeton, New Jersey 08544-1010

rwc/950803

LIST OF ENCLOSED HARDWARE

- 1 Assembled and wired benchmark testing system including:
 - Audiological Engineering Corporation #V1242 transducer (250 Hz resonance) and cable
 Audiological Engineering Corp Phone: (617) 623-5562
 35 Medford Street FAX: (617) 666-8430
 Somerville, Massachusetts 02143
 - KNOWLES® BU1771 Accelerometer (mounted on underside of V1242) and cable
 Knowles Electronics Inc. Phone: (708) 250-5100
 1151 Maplewood Drive FAX: (708) 250-0575
 Itasca, Illinois 60143
 - Both **pre-mounted** on a foam block to control application force
 - double-stick tabs to re-attach accelerometer to vibrator, if necessary

DESCRIPTION AND INSTRUCTIONS FOR USE OF VIBRATOR SYSTEM HARDWARE (DF)

DESCRIPTION OF AUDIOLOGICAL ENGINEERING SKIN TRANSDUCERS AND METHODS OF EXCITATION

The Model #V1242 transducer being supplied in this package for use as a performance benchmark is a tuned (250 Hz, nominal) variable reluctance skin excitor. The essential construction is a cantilevered hardened iron beam with an attached magnet and mass selected to provide a peak resonance at 250 Hz. The cantilevered beam is mounted from one end of the case with the magnet held above a coil with a center soft-iron slug. When the coil is appropriately excited, the beam vibrates and transmits energy to the outer housing which is, in turn, transmitted to the skin. The nominal coil impedance is 42 ohms. The inner construction is indicated in Figure 1. A simple way of driving these devices is indicated in Figure 2, and the frequency response of this class of vibrators is shown in the representative Calibration Curve)

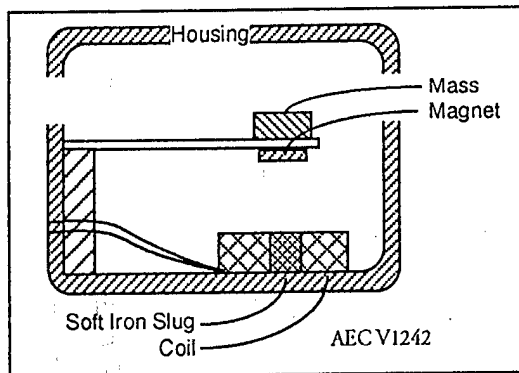

Figure 1

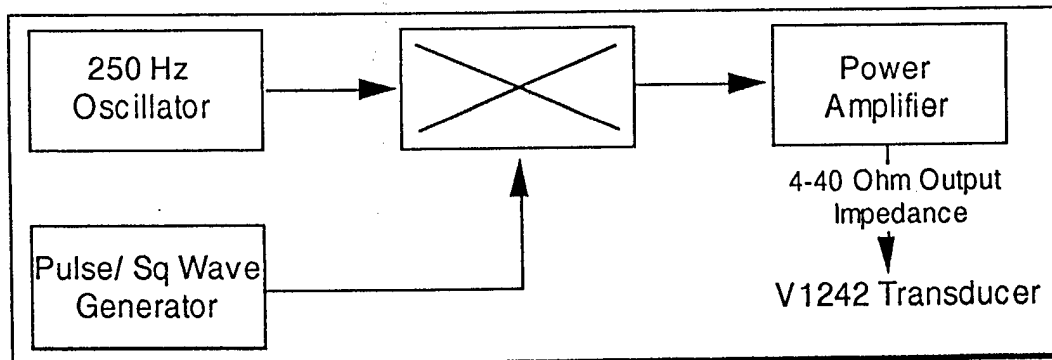
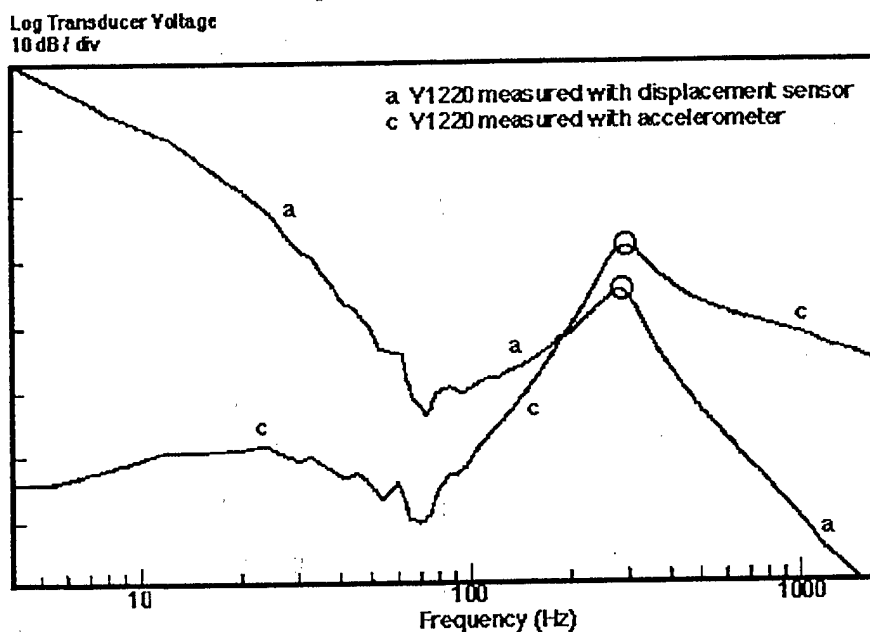

Figure 2

AUDIOLOGICAL ENGINEERING CORP.
35 Medford Street
Somerville, MA 02143

Response Testing of Audiological Engineering Transducers



Frequency response for Y1220 (nom. 250 Hz resonance) transducer loaded on forearm

Typical Calibration Curve

The protocols to be used in testing sensory magnitude levels with the enclosed system will be detailed in a following section. Information regarding general use of the AEC transducers is included here for your interest.

Driving Waveforms The best driving method is to use a 250 Hz sinusoidal carrier amplitude-modulated in some way to produce bursts of vibration (see Figure 3 which is a 400-Hz burst but is representative of this device). In order to avoid adaptation, the pulse or square wave generator used for modulation is often set to a low repetition rate: 5 Hz or less (200 msec or more for each burst and associated inter-burst interval), and if a pulse waveform is used, the minimum pulse width should be on the order of 4 or 5 cycles of the 250 Hz excitation frequency (20 msec or longer). [One reason for the several minimal cycles is to allow the amplitude of the resonant device to achieve maximum levels - rwc]. These numbers are arbitrarily chosen; the main point is not to use an unmodulated 250-Hz signal to characterize the perceptual experience since this steady signal will provide an unrealistically high estimate of how strong a signal is actually required and adaptation can take place. See protocols for actual durations to be used in a later section.

Similarly, be aware of the fact that, for some applications, if the slow modulating waveform and the 250-Hz signals are not synchronized (as generally will be the case) when the start or end of the modulation pulse occurs at other than zero axis crossings of the 250-Hz signal, extra perceptual cues may occur from onset/offset transients. The net result of this is that perceptual thresholds may be lower than if these transients were not present. Note that from the point of view of this project, the effective lowering of thresholds probably is desirable, but certainly one should be aware of what is going on.

Drive Levels In general, one can drive these transducers at quite high voltage levels without undue heating or damage to the units. A good guideline is to use maximum signals such that when the transducer is held firmly in the hand (or pressed firmly against the body), a signal at 250 Hz does not cause the inner mechanism to clatter (i.e., the beam end hitting the inner case or the coil). It will be found that this occurs at voltages around or slightly above 6 volts p-p (around 2 volts rms). Further away from resonance larger

signals can be used; exactly at resonance, somewhat smaller signals. Again, see the testing protocols for the recommended drive levels.

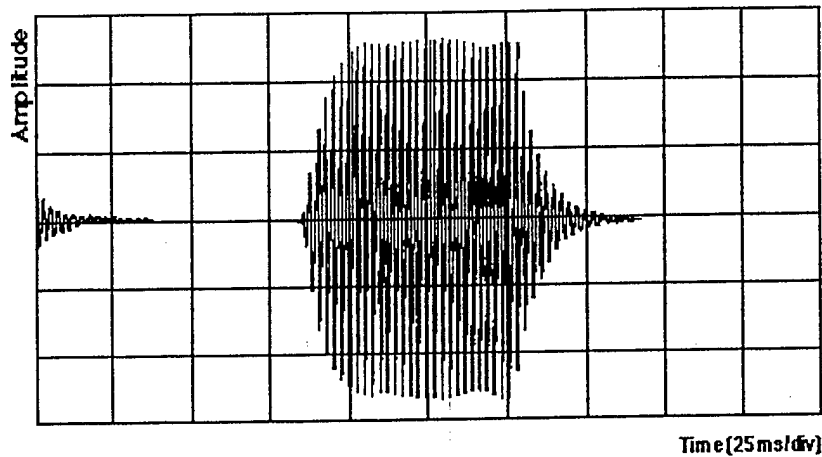

Y1420 (nominal 400 Hz resonance), loaded on forearm.
Square wave modulation on 400 Hz carrier.

Figure 3

DESCRIPTION AND CHARACTERISTICS OF KNOWLES® ACCELEROMETER (df/rwc)

The Knowles BU1771 Accelerometer is a small (7.9 x 5.6 x 4.1 mm, 0.28 gm) general-purpose accelerometer with high vibration sensitivity, a built-in FET preamplifier, and a flat bandwidth that covers the range of frequencies typically studied in tactile research (20 Hz to over 2 KHz). A Knowles accelerometer is already mounted (with double-stick tape) to the underside of the enclosed V1242. The leads connecting the accelerometer to the resistor/ battery points shown in the circuit in Figure 4 have already been attached. Although the accelerometer is durable, a fall to a hard surface from several cm may damage the device, and they are difficult to obtain in small quantities. In addition, high temperatures should be avoided. For other concerns, please read the attached Knowles Technical Bulletin (TB8: The Transducer Environment). In the Knowles Data Sheets (also attached), a two-wire circuit is described (reproduced below as Figure 4). A battery should be used for the 1.5 V DC voltage source to minimize AC interference. Another (3-wire) circuit will provide an additional 10 dB of sensitivity, but Franklin reports that, for the purposes described here, the added sensitivity will not be required.

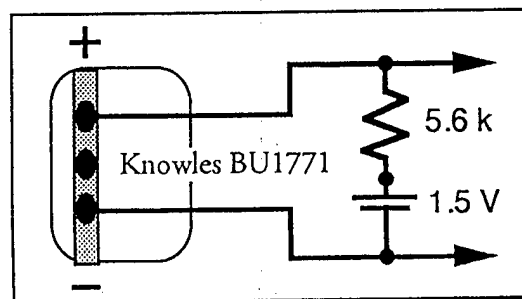

Figure 4

The preferred method of attachment of the accelerometer to the AEC V1242 is to use double-stick tape of the type used for mastoid vibrators (two such disks are enclosed). Again, because the actual placement location of the accelerometer on the device will influence its output, and to standardize across laboratories, the accelerometer has been pre-mounted onto the vibrator, centered in the mold circle on the face opposite the colored sticker. The V1242 vibrator/ Knowles BU1771 unit has been pre-mounted onto a

sheet of foam (with a bit of heat glue) (see the cross-sectional drawing in Figure 5). In case the unit becomes dislodged from the foam, re-mount it onto the top of the foam "hill" that has a small indentation that will fit the BU1771, a placement that should fall right under the base of the thumb if the hand is placed within the drawn outline. The wires should lead off to the right. Because acceleration is output from the device, determining displacement amplitude will require calibration to determine its sensitivity and mathematical conversion.

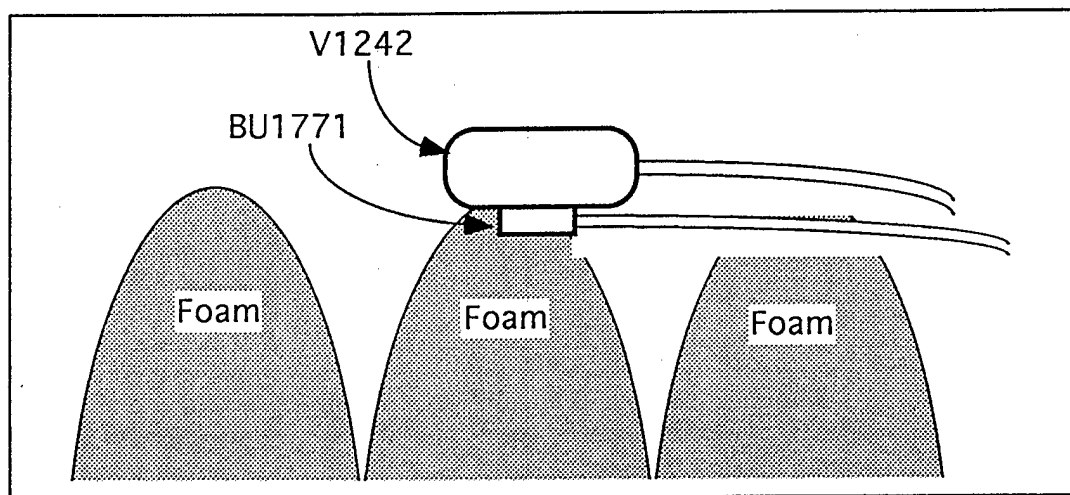

Figure 5

PSYCHOPHYSICAL TESTING PROTOCOLS, DATA COLLECTION & REPORTING

(rwc/jcc/jmw)

The following section will describe experimental protocols to be followed to provide necessary information on the tactile transducer system that you are developing. These guidelines must be followed conscientiously in order to provide usable data on your system. If you have any questions regarding any portion of these guidelines, do not hesitate to contact one of the last three contributors listed on the front page. Your care in this regard is essential. Once the data have been collected on copies of the data sheets provided at the end of this writeup, we will analyze the data and generate a written report of your results for the ATD and NAMRL.

The purpose of these measurements is to determine whether your newly-developed device is capable of producing a standard level of perceived intensity and to define the system requirements of your device to produce this benchmark sensation level. The measurement procedure described below should provide a relatively quick way to determine both of these pieces of information. The idea is to provide a standard level of stimulation using the enclosed V1242 transducer and to adjust the intensity of your device until the subject, who is touching both devices, judges them to be equal in perceived intensity. Experience has demonstrated that naive individuals can readily compare the perceived intensities, frequencies, or other qualities of sensory stimuli against a stable standard using techniques to be described below.

The apparatus will involve two stimulators: the benchmark system provided in this package, and the prototype tactor. Participants will feel bursts of vibration presented to the skin from both devices, and will be asked to report whether the sensation produced by the new device is stronger, equal to, or weaker than that produced by the benchmark. The trial procedure is readily learned, even by children and elderly persons completely unfamiliar with such testing. By adjusting the intensity of the comparison over trials, the experimenter can obtain a reliable estimate of the intensity that produces a psychophysical match.

AUDIOLOGICAL ENGINEERING CORP.

35 Medford Street

Somerville, MA 02152

1. Subjects.

Because of known differences among individuals in their sensitivities and understanding of experimental task demands, 10 participants should be used in the comparison tests in order to obtain a valid average. Similarly, age and gender may influence the performance, so these will be recorded on the attached data sheets. Subjects can be lab/ shop personnel, students, or persons recruited by advertisement. Typically we pay out subjects \$5 per 1-hour session for such testing as an incentive to do well.

2. Apparatus.

The apparatus includes the enclosed benchmark system, a timer circuit, a sine wave generator, and the device under test with its associated driving circuitry. The benchmark system has already been prepared for use in this study. The signal source used for the calibration levels was an Exact 128 function generator set to produce a 250 Hz sinusoid, having an output impedance of 50 ohms. To set the benchmark intensity properly, first load the benchmark with a hand or small (c. 200 gm sandbag) to depress the supporting foam cone to the level of the adjacent ridges (not to the adjacent valleys!) Turn on the accelerometer (by connecting the battery) and the signal source for the benchmark. Turn the 250-Hz sinusoidal signal on and adjust the intensity of the driving signal to the loaded system to produce an accelerometer output of 26 mV_{rms} (about 2.12 V_{rms} (6.0 V p-t-p)). [Cholewiak, Craig, Weisenberger & Jarmul should use 23 mV_{rms} with their particular systems.] *These values have been determined to apply to your particular V1242 and accelerometer in benchtop calibration by rwc.* This level will produce a sensation that is about 40 dB above threshold for the average subject on the thenar eminence of the palm (at the base of the thumb), based on data in the literature. The sensation on the palm of the hand produced by this signal level will be the standard or benchmark against which that produced by the device under development will be compared.

If, in the following procedure, an adequate match cannot be made, try adjusting the stimulus parameters of your device. For example, changing the stimulus frequency, waveform, or application force can all affect the perceived magnitude of vibrotactile stimuli. Manipulate these variables to optimize your system, but please make sure to define these parameters on the reporting data sheets for each individual. If these manipulations are not successful and you are unable to achieve a match with the benchmark stimulus, then a second benchmark level can be used. It is important that your device be characterized with the first benchmark level if it is at all possible, to provide information required by the ATD Program. The second level that can be used, *if necessary*, is the voltage sufficient to produce an output accelerometer signal that is *one tenth* of the original, now producing a sensation that is about 20 dB above threshold for the average subject. Again, we prefer that the match be made to the higher-intensity signal. In either case, make sure to indicate both the driving voltage and the resulting accelerometer output on the reporting data sheets.

An additional control that should be implemented is intended to minimize any influences on the judgments based on the acoustic differences between the devices. Experimental subjects should wear headphones with white noise at a level sufficient to mask any sounds generated from either vibrotactile device. This level depends on the devices under test. Responses can be given verbally, with each hand on one of the devices.

3. Body Site.

The site to be tested will be the thenar eminence of the palm of the hand. This area is the large fleshy pad at the base of the thumb. This site was chosen because a large body of literature is available for vibrotactile stimulation of the thenar, and it is broad enough for the largest of the proposed devices (c. 2.54 cm, diameter).

4. Procedure.

Reliable results are generally obtained when subjects are allowed to use a "bracketing" technique. With this technique, subjects are presented a level of the comparison stimulation that they judge to be more

intense than the standard, and then a level they judge to be equal to the standard, and then less intense than the standard. The order is then reversed. That is, the series will go from levels that are judged to be less intense, to equal levels, to levels that are judged to be more intense. By allowing subjects to feel levels that are more intense and less intense than the standard, subjects gain confidence in judging when the two levels of stimulation are equal.

The subject, wearing headphones to mask the noise of the devices, places the left hand on the foam-supported test surface with the thenar eminence of the palm resting on the V1242 vibrator/ BU1771 accelerometer unit. As described above, sufficient force should be used to depress the foam cone with the attached vibrator down to the level of the adjacent connecting ridges (not all the way down to the lowest valley level).

On each trial, subjects receive the standard stimulus on the left palm followed by the comparison stimulus on the right palm (or another site as desired after the right palm measurements have been completed). A trial, shown schematically in Figure 6, would take approximately 10 sec: at least a 200 msec vibratory burst on the benchmark system on the left palm, a 1000 msec interstimulus interval, and a second identical burst on the comparison or device under test, at the other site. If accurate timing of the stimuli is a problem, simply switching the stimuli on and off for about a second each would be sufficient. The vibrotactile loudness of such stimuli stops increasing with duration after about 150-200 msec. Following the second burst, the subject would verbally respond by saying whether the comparison stimulus feels more intense, less intense, or equal to the standard stimulus. The intensity of the standard stimulus on the Franklin V1242 should stay at the same level over trials, while the burst of vibration on the other site (the comparison stimulus produced by your device) varies over trials to be stronger and weaker than the benchmark. We are aware that there might be a temporal order bias owing to the fact that the comparison is always presented last, but it will be consistent across observers and will probably be on the order of only 1-2 dB.

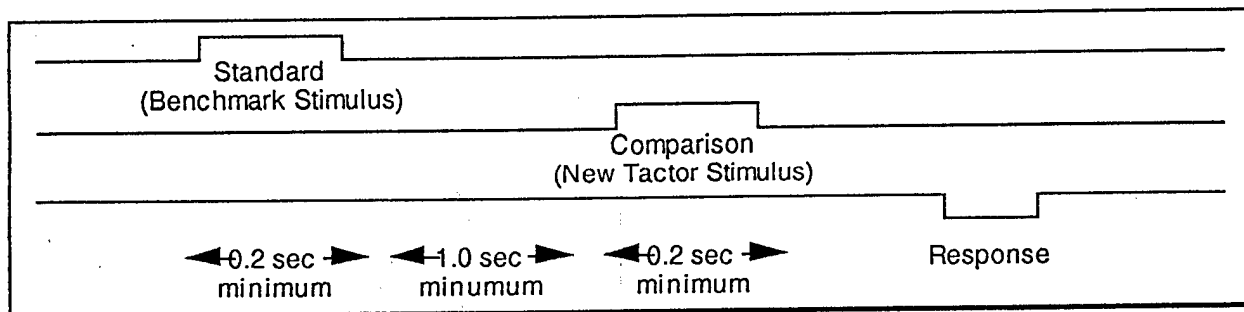

Figure 6

On an ascending block of trials, you begin with an intensity level that the subject judges to be weaker than the standard. After each trial (assuming the subject responds "weaker,") the intensity of the comparison is increased. At some point the subject may respond "equal." The intensity of the comparison is increased until the subject responds "stronger." The intensity is then decreased until the subject responds "equal." At this point the intensity is adjusted up and down for a few trials until the subject believes that s/he has the best setting for equality. This ends the first series of trials. If the next block is a descending series of trials, begin with the comparison set to a level that the subject says is clearly stronger and gradually reduce the intensity. Some practice will be required to determine how much to change the comparison on each trial. Try to determine a size of change (of voltage, current, pulse number, or however you change the intensity of your device) that is perceptible to the subject (that they can tell that the stimulus has changed) without being too large a change and losing precision.

We recommend that you begin each testing session with two practice blocks of trials, one ascending and one descending. Tell the subjects that these are practice trials. After these blocks, take four blocks of trials in the order: ascending, descending, descending, ascending. Please record the data on copies of the attached reporting data sheets. This procedure should take less than 45 minutes per subject.

To repeat, if you have any questions regarding these experimental protocols or any portion of these guidelines (for example such as setting the step size for intensity changes), please do not hesitate to contact Cholewiak, Craig, or Weisenberger prior to testing your subjects (phone/ fax numbers on the first page of this writeup.).

5. Further Testing.

Although the palm is not the abdomen, the technique described will provide, among other things, one measure allowing for an objective comparison among the devices based on one of the most crucial criteria: what is felt by the user. Certainly, it is expected that different frequencies, sites, and modes of pattern generation will likely favor one device over another in direct comparisons, but the comparison arising from the match described here will allow for evaluation of device efficiency and efficacy in one standardized situation. The developer is encouraged to plot the functional relationships for their particular devices on any number of measures, such as waveform (square-wave stimuli may feel stronger for a given input intensity with some devices), body site, frequency or pulse repetition rate, etc. In each case, the standard defined earlier can still be used. It is possible for subjects to learn to ignore all characteristics of a sensation except the one under test. For example, although a square wave burst may feel "brighter" than a sinusoid, the loudness of the two sensations can still be extracted and compared.

6. Reporting Results.

Contact us now to let us know when you anticipate being able to complete this comparison. When all of the data have been collected, return the package of response sheets to Roger Cholewiak at the address listed above. These data will be used in reports of the ATD's progress so are welcomed as soon as available.

Tactor Organization _____ Device Identification _____
 Participant's Identification Number _____ Date _____
 Participant's handedness _____ right / left _____ Age _____ Sex _____ M / F _____
 V1242 Identification Number _____ V1242 Input Voltage _____ V_{rms}
 Accelerometer Output Voltage _____ mV_{rms} Stimulus Frequency _____ Hz
 Intensity variation: Input Voltage _____ Input Current _____ Other _____
 Other parameters (e.g. body site, intensity units): _____

Trial	Sample Ascending		PRACTICE Ascending		PRACTICE Descending	
	Intensity Level	Response	Intensity Level	Response	Intensity Level	Response
1	13	W				
2	15	W				
3	17	W				
4	19	W				
5	21	E				
6	23	E				
7	25	E				
8	27	E				
9	29	S				
10	31	S				
11	33	S				
12	35	S				
13	37	S				
14	39	S				
15	41	S				
16	43	S				
17						
18						
19						
20						

Enter value for varied dimension in intensity columns.
 Responses = "S" for stronger, "E" for equally loud, "W" for weaker.

Tactor Organization _____

Device Identification _____

Participant's Identification Number _____

Date _____

Participant's handedness _____ right / left _____

Age _____ Sex M / F _____

V1242 Identification Number _____

V1242 Input Voltage _____ V_{rms}

Accelerometer Output Voltage _____ mV_{rms}

Stimulus Frequency _____ Hz

Intensity variation: Input Voltage _____ Input Current _____ Other _____

Other parameters (e.g., body site, intensity units): _____

Trial	Ascending		Descending		Descending		Ascending	
	Intensity Level	Response	Intensity Level	Response	Intensity Level	Response	Intensity Level	Response
1								
2								
3								
4								
5								
6								
7								
8								
9								
10								
11								
12								
13								
14								
15								
16								
17								
18								
19								
20								

Enter value for varied dimension in intensity columns.
 Responses = "S" for stronger, "E" for equally loud, "W" for weaker.

rwel950803

950802-Calibration of Audiological Engineering Corp V1242 Vibrators delivered to rwc 7/21/95

- Exact 128 function generator set to 250 Hz, continuous, $2.12 V_{rms}$ (6.0 V p-t-p)
- Knowles accelerometer with 2-wire circuit as shown in specification sheets
- Accelerometer attached to V1242 centered on circular mold pattern on V1242 case
- Vibrator/ accelerometer resting on latex foam loaded with a small (175 gm) sandbag to produce force described in text
- K Accel = Knowles Accelerometer output in mV_{rms} to $2.12 V_{rms}$ (6.0 V p-t-p) input - 3 readings
- P Accel = Knowles Accelerometer output in mV_{rms} to produce c. 20 μ peak
(measured with PCB 309A (s/n 2144) = $18 mV_{rms}$, mounted on Knowles Accelerometers)

Vibrator #	K Accel ₁ (loaded)	K Accel ₂ (loaded)	K Accel ₃ (loaded)	P Accel (loaded)	Test Site	Resonant Freq (unloaded)
1	34	37	40	.022	Craig	275
2	30	31	29	.026	Beebe	288
3	31	32	29	.025	Churchill	290
4	28	29	26	.023	Weisenberger	283
5	21	21	19	.026	Ensign	295
6	29	29	26	.026	Franklin	293
7	35	37	33	.026	Johnson	288
8	26	26	23	.026	Langberg	298
9	20	20	18	.023	Jarmul	297
10	26	26	24	.027	Weed	298
11	21	21	19	.026	Wells	298
12	21	22	22	.023	Cholewiak	300

#12= about $2.45 V_{rms}$ (6.93 V p-t-p) input for standard output

Dr. David J. Beebe
Department of Biomedical Engineering
Louisiana Tech University
711 S. Vienna Street
Ruston, LA 71270

Dr. James C. Craig
Indiana University
Department of Psychology
Bloomington, IN 47405-1301

Dr. David L. Wells
Sarcos Research Corporation
360 Wakara Way
Salt Lake City, UT 84108

Mr. A. David Johnson, President
TiNi Alloy Company
1621 Neptune Drive
San Leandro, CA 94577

Dr. Janet M. Weisenberger
The Ohio State University
Speech and Hearing Science
110 Pressey Hall, 1070 Carmack Road
Columbus, OH 43210-1002

Dr. Edward H. Jarmul
NAVAEROMEDRSCHLAB
51 Hovey Road, CODE 22-ATD
Pensacola, FL 32508-1046

Mr. David Franklin
Research Director and President
Audiological Engineering Corporation
5 Medford Street
Somerville, MA 02143

Mr. Thomas H. Ensign, President
Engineering Acoustics, Inc
1490 Gene Street
Winter Park, FL 32789

Dr. Russel J. Churchill
American Research Corporation of Virginia
P. O. Box 3406
Radford, VA 24143-3406

Dr. Edwin Langberg
Sensor Electronics, Inc.
56 Bridge Road
Medford, NJ 08055-4205

Mr. Herman R. Weed
The Ohio State University
Department of Electrical Engineering
205 Dreese Laboratory, 2015 Neil Avenue
Columbus, OH 43210-1272

Dr. Roger W. Cholewiak
Department of Psychology - Green Hall
Princeton University
Princeton, New Jersey 08544-1010

rwc/950803

AUDIOLOGICAL ENGINEERING CORP.
35 Medford Street
Somerville, MA 02143

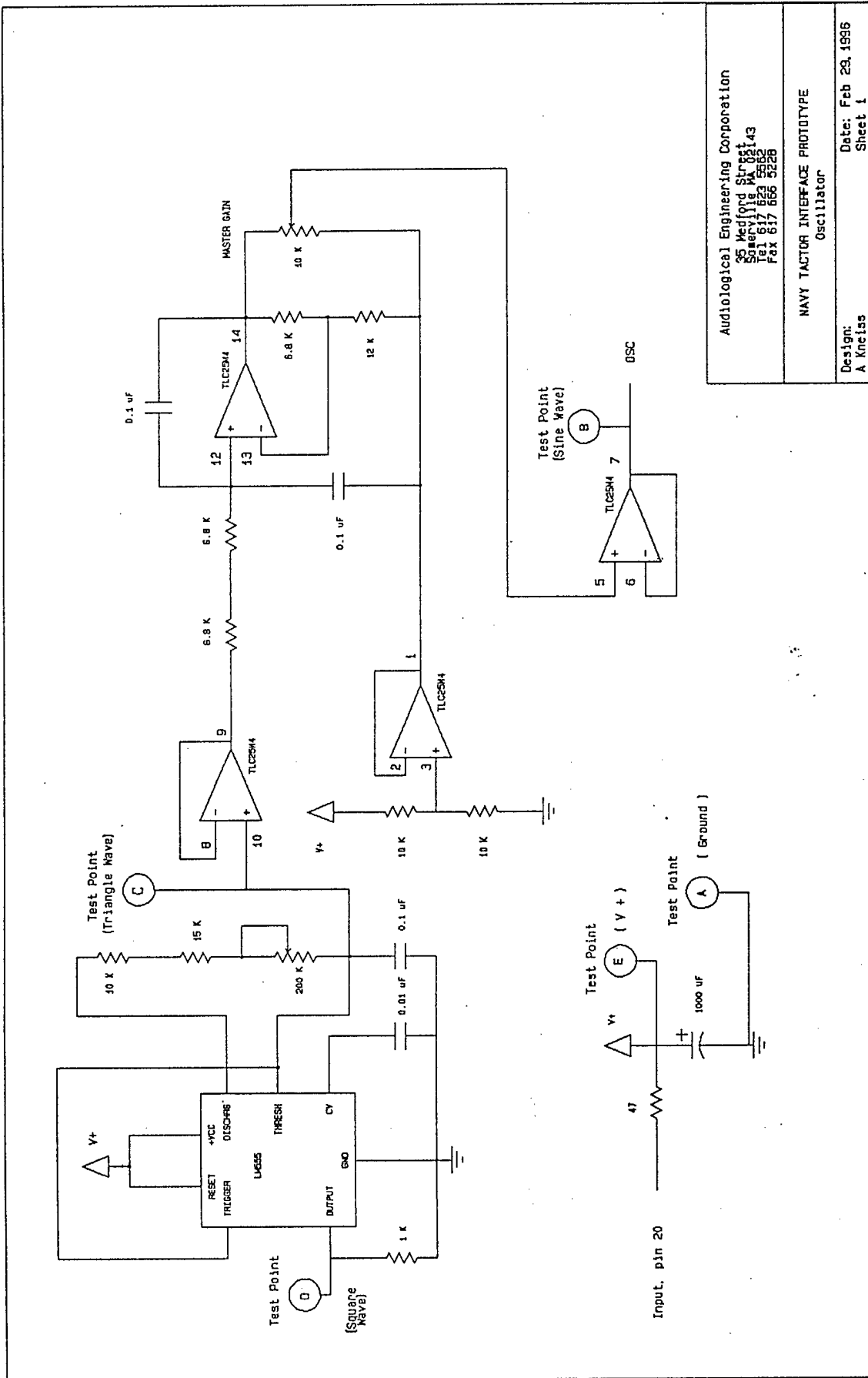

Audiological Engineering Corporation
 35 Medford Street
 Somerville, MA 02143
 Tel 617 823 5522
 Fax 617 866 5228

NAVY TACTOR INTERFACE PROTOTYPE
 Oscillator

Design: A Knickas
 Date: Feb 29, 1996
 Sheet 1

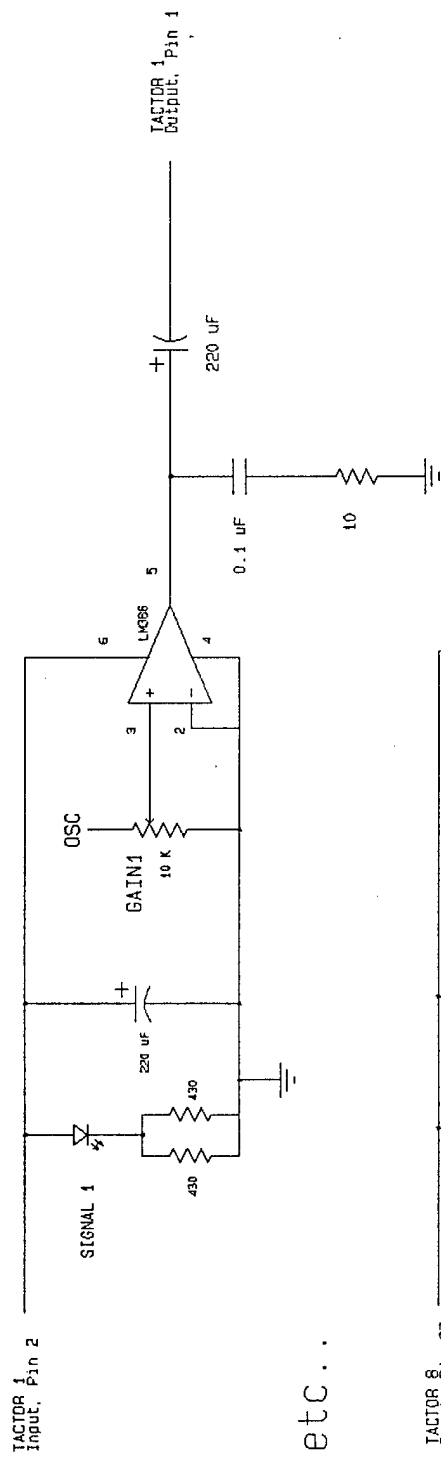

etc...

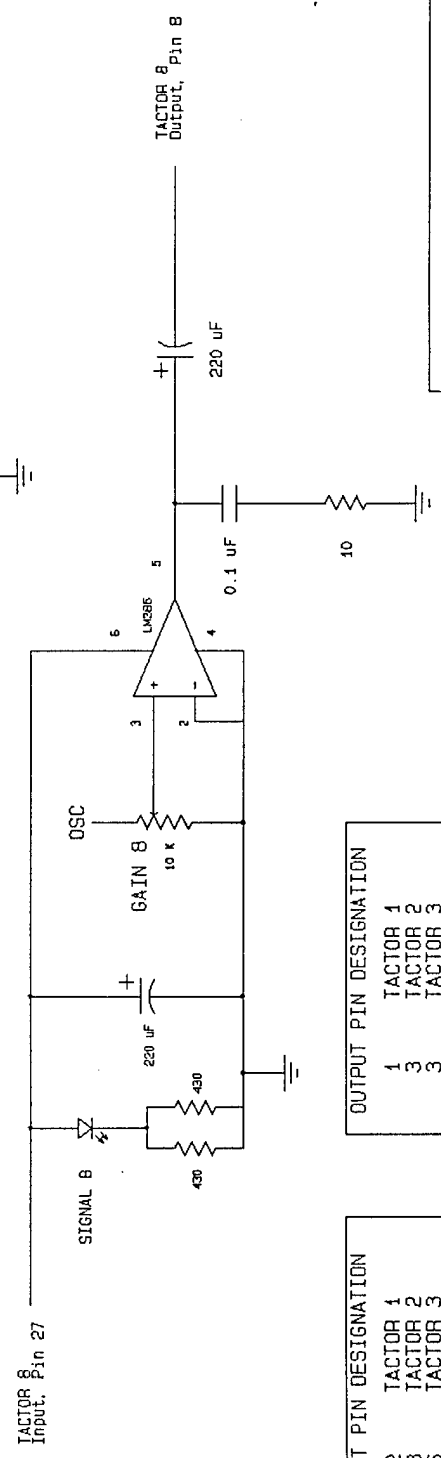

OUTPUT PIN DESIGNATION

1	TACTOR 1
3	TACTOR 2
3	TACTOR 3
4	TACTOR 4
5	TACTOR 5
6	TACTOR 6
7	TACTOR 7
8	TACTOR 8
9-15	GROUND

INPUT PIN DESIGNATION

2	TACTOR 1
3	TACTOR 2
6	TACTOR 3
14	TACTOR 4
17	TACTOR 5
20	V +
21	TACTOR 6
24	TACTOR 7
27	TACTOR 8
37	GROUND

Audio Logical Engineering Corporation
 35 Medford Street
 Somerville, MA 02143
 Tel 617 623 5252
 Fax 617 666 5226

NAVY TACTOR INTERFACE PROTOTYPE
 Driver Channels 1-8

Date: Feb 29, 1995
 Sheet 2
 Design:
 A. Knais

Technical Specifications:

Parameter:	Operating Range:	NOTES:
V +	5.0 V - 10.2 V	Depending on the load impedance and the number of factors being driven, higher voltages may provide inappropriate currents for operation.
I total	< 1.0 A	
I typical	(5.0 V) 400 mA	(10.0 V) 800 mA
F	40 Hz - 390 Hz	Frequency adjust is a 20 turn pot.
Distortion	~1/2 Master Gain Range	The MASTER GAIN control is capable of overdriving the LM885's. At low levels, the signal out of the drivers will be a sine wave. As they are overdriven, it becomes a square wave.
Tactor Impedance (VC1080)	8 Ohms	Disk-shaped voice coil wideband tactors.
Tactor Impedance (V1220)	22 Ohms	Small white plastic-cased tactors.

Audiological Engineering Corporation
 35 Medford Street
 Somerville, MA 02143
 Tel 617 623 5552
 Fax 617 666 5228

NAVY TACTOR INTERFACE PROTOTYPE
 Technical Specifications

Design: A Kneiss
 Date: Feb 29, 1996
 Sheet 3