

NAVAL POSTGRADUATE SCHOOL MONTEREY, CALIFORNIA



THESIS

**IMPROVED MAINTENANCE AND READINESS
THROUGH THE USE OF BUILT IN TEST (BIT)
IN THE FIRE CONTROL SYSTEM OF THE
MULTIPLE LAUNCH ROCKET SYSTEM (MLRS)**

by

Charles Doyle Lassitter

December, 1996

Thesis Advisor:

Jane N. Feitler

Approved for public release; distribution is unlimited.

19970527 055

REPORT DOCUMENTATION PAGE

Form Approved OMB No. 0704-0188

Public reporting burden for this collection of information is estimated to average 1 hour per response, including the time for reviewing instruction, searching existing data sources, gathering and maintaining the data needed, and completing and reviewing the collection of information. Send comments regarding this burden estimate or any other aspect of this collection of information, including suggestions for reducing this burden, to Washington Headquarters Services, Directorate for Information Operations and Reports, 1215 Jefferson Davis Highway, Suite 1204, Arlington, VA 22202-4302, and to the Office of Management and Budget, Paperwork Reduction Project (0704-0188) Washington DC 20503.

1. AGENCY USE ONLY <i>(Leave blank)</i>	2. REPORT DATE December 1996	3. REPORT TYPE AND DATES COVERED Master's Thesis	
4. TITLE AND SUBTITLE IMPROVED MAINTENANCE AND READINESS THROUGH THE USE OF BUILT IN TEST (BIT) IN THE FIRE CONTROL SYSTEM OF THE MULTIPLE LAUNCH ROCKET SYSTEM (MLRS)		5. FUNDING NUMBERS	
6. AUTHOR(S) Lassitter, Charles D.			
7. PERFORMING ORGANIZATION NAME(S) AND ADDRESS(ES) Naval Postgraduate School Monterey CA 93943-5000		8. PERFORMING ORGANIZATION REPORT NUMBER	
9. SPONSORING/MONITORING AGENCY NAME(S) AND ADDRESS(ES)		10. SPONSORING/MONITORING AGENCY REPORT NUMBER	
11. SUPPLEMENTARY NOTES The views expressed in this thesis are those of the author and do not reflect the official policy or position of the Department of Defense or the U.S. Government.			
12a. DISTRIBUTION/AVAILABILITY STATEMENT Approved for public release; distribution is unlimited.		12b. DISTRIBUTION CODE	
<p>13. ABSTRACT <i>(maximum 200 words)</i></p> <p>As the Army continues to face force and budget reductions while maintaining a high state of readiness, reliance on advanced technology systems is becoming more essential. The Army's leadership has recognized this challenge and is seeking ways to ensure readiness.</p> <p>This thesis explores the application of the built in test (BIT) maintenance concept in supporting readiness in the Fire Control System (FCS) of the Multiple Launch Rocket System (MLRS). It provides background on the current Fire Control System and discusses factors both internal and external to the system that are driving the upgrade. Projected benefits gained from BIT are in terms of readiness through reduction in Mean Time To Repair (MTTR), cost savings, and compression of the maintenance levels. Application of BIT into other systems is covered.</p> <p>BIT is one method currently being developed to maintain and improve readiness despite continued force and budgetary reductions. The goal of this thesis is to show how technology can be used to support readiness by increasing efficiency while minimizing costs.</p>			
14. SUBJECT TERMS Built In Test (BIT); Improved Fire Control System (IFCS); Multiple Launch Rocket System (MLRS)		15. NUMBER OF PAGES 82	16. PRICE CODE
17. SECURITY CLASSIFICATION OF REPORT Unclassified	18. SECURITY CLASSIFICATION OF THIS PAGE Unclassified	19. SECURITY CLASSIFICATION OF ABSTRACT Unclassified	20. LIMITATION OF ABSTRACT UL

NSN 7540-01-280-5500

Standard Form 298 (Rev. 2-89)
Prescribed by ANSI Std. Z39-18 298-102

Approved for public release; distribution is unlimited.

**IMPROVED MAINTENANCE AND READINESS
THROUGH THE USE OF BUILT IN TEST (BIT)
IN THE FIRE CONTROL SYSTEM OF THE
MULTIPLE LAUNCH ROCKET SYSTEM (MLRS)**

Charles D. Lassitter
Captain, United States Army
B.S., University of Florida, 1989

Submitted in partial fulfillment
of the requirements for the degree of

MASTER OF SCIENCE IN MANAGEMENT

from the

NAVAL POSTGRADUATE SCHOOL

December 1996

Author:



Charles D. Lassitter

Approved by:



Jane N. Feitler, Principal Advisor

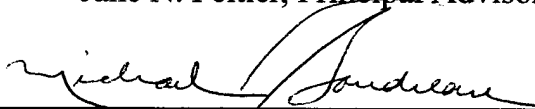

Michael W. Boudreau, Associate Advisor

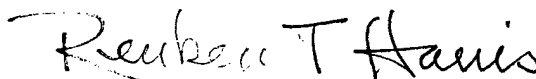

Reuben T. Harris, Chairman Systems Management

ABSTRACT

As the Army continues to face force and budget reductions while maintaining a high state of readiness, reliance on advanced technology systems is becoming more essential. The Army's leadership has recognized this challenge and is seeking ways to ensure readiness.

This thesis explores the application of the built in test (BIT) maintenance concept in supporting readiness in the Fire Control System (FCS) of the Multiple Launch Rocket System (MLRS). It provides background on the current Fire Control System and discusses factors both internal and external to the system that are driving the upgrade. Projected benefits gained from BIT are in terms of readiness through reduction in Mean Time To Repair (MTTR), cost savings, and compression of the maintenance levels. Application of BIT into other systems is covered.

BIT is one method currently being developed to maintain and improve readiness despite continued force and budgetary reductions. The goal of this thesis is to show how technology can be used to support readiness by increasing efficiency while minimizing costs.

TABLE OF CONTENT

I. INTRODUCTION	1
A. AREA OF RESEARCH	1
B. RESEARCH QUESTION	1
1. Primary	1
2. Supporting Research Questions	1
C. DISCUSSION	2
D. SCOPE	3
E. METHODOLOGY	3
F. BACKGROUND OF MLRS	4
G. BACKGROUND OF FCS	7
H. BACKGROUND OF IFCS	10
I. BACKGROUND OF CURRENT MAINTENANCE SYSTEM	13
J. MLRS CURRENT MAINTENANCE CONCEPT	16
K. MAINTENANCE CONCEPT WITH IFCS	18
L. SUMMARY	22
II. EVOLUTION OF THE BIT MAINTENANCE CONCEPT	23
A. INTRODUCTION	23
B. DOCTRINE AND STRATEGY	23
1. National Military Strategy	24
2. Logistics	27

C.	BUDGET REDUCTIONS	29
1.	DoD Budget	29
2.	Army Budget	31
D.	READINESS GOALS AND OBJECTIVES	35
1.	Introduction	35
2.	Defining Readiness	35
3.	Equipment	36
4.	Maintenance Personnel	38
5.	Structure	40
E.	SUMMARY	42
III.	ADVANTAGES AND DISADVANTAGES OF BIT MAINTENANCE CONCEPT	43
A.	INTRODUCTION	43
B.	READINESS	43
C.	PERSONNEL	49
D.	COST	53
E.	SUMMARY	57
IV.	SUMMARY	59
A.	INTRODUCTION	59
B.	ANSWERS TO RESEARCH QUESTIONS	59
C.	REASONS FOR INTEGRATING BIT INTO OTHER SYSTEMS ...	62
D.	BARRIERS TO FIELDING	63
E.	FUTURE RESEARCH	64

F. CONCLUSION	65
LIST OF REFERENCES	67
INITIAL DISTRIBUTION	69

ACKNOWLEDGMENT

This author would like to thank the countless military members and civilians at the Multiple Launch Rocket System Program Office and those at other installations who provided me with guidance and cooperation. I would like to recognize the support and dedication provided by my family during this project. Thanks Christine, Kathleen, Matthew, and Rachel. Finally, and most importantly I would like to thank God for his guidance, comfort and peace that only he can provide.

I. INTRODUCTION

A. AREA OF RESEARCH

This thesis will explore the benefits of incorporating the built in test (BIT) maintenance concept into a major weapon system. Specifically, the thesis will focus on the integration of the BIT maintenance concept into the upgrade of the Improved Fire Control System (IFCS) in the Army's Multiple Launch Rocket System (MLRS).

This thesis will examine the BIT maintenance concept's effect on improving maintenance and readiness in the IFCS. In the thesis I will review the effects of the integration of the BIT concept on maintenance personnel, test equipment, and training requirements.

B. RESEARCH QUESTION

1. Primary

Will the Built in Test (BIT) maintenance concept significantly improve maintenance and readiness in the Improved Fire Control System (IFCS), in the Multiple Launch Rocket System (MLRS), while reducing costs?

2. Supporting Research Questions

- What is the anticipated gain in the MLRS FCS availability with the use of BIT?
- Does the BIT have prognostic and diagnostic capability?
- What are the effects on equipment requirements with the use of BIT?
- How have budgetary factors influenced the integration of BIT?
- What are the effects on personnel staffing with the use of BIT?

- What are the effects on training for the operator/crew and the maintenance personnel?
- How will the required publications change?
- What is the anticipated cost savings for repair parts?
- What are the barriers to fielding a system using BIT?
- Have other systems incorporated BIT?
- What has been the result in these systems?

C. DISCUSSION

The Army's current maintenance system (old system) is composed of five levels; operator, organizational, direct support, general support and depot. The MLRS is a Corps level asset and is maintained using operator, organizational, direct support and depot level maintenance. The integration of the BIT will reduce the levels of maintenance from four to three. The new levels of maintenance (new system) will be organizational (crew), direct support and depot.

In this thesis, I will compare the old system to the new system. This comparison will evaluate the cost of repair parts needed, primarily LRUs and circuit cards at the organizational and the direct support level. I will also compare the system's readiness and explore the projected improvements in the amount of downtime for the system. The term maintenance is used to describe the process of repairing a failed system or preventing a system from failing. The term readiness is used to describe the system's ability to remain operational and mission capable. This readiness rating will be presented as an operational availability

percentage and compared to the recognized Department of the Army goal of 90 percent. This goal is established in Army Regulation 700-138.

Finally, I will explore the effects on the maintenance process from reducing the levels of maintenance from four to three. I will examine the effects of this reduction on personnel staffing, training, equipment and publications and the cost or savings of these reductions.

D. SCOPE

The scope of this thesis will be to look at the Army's Multiple Launch Rocket System's (MLRS), Improved Fire Control System including the integration of the BIT maintenance concept. The study will explore the effects of the upgrade and the projected benefits associated with readiness. A review of how changing doctrine, strategy and budget have affected this system's upgrade will also be presented.

The M270 MLRS is comprised of the M269 Loader Launcher Module, the M993 chassis, and the Fire Control System (FCS). The concurrent upgrading of the M269 Loader Launcher Module of the MLRS will not be covered in this thesis. The tactics or doctrine, used by the Field Artillery Commander to employ the MLRS against the enemy will not be covered in this thesis beyond the background provided later in this chapter. Finally, external systems used to provide fire mission data to the MLRS will be outside the scope of this thesis.

E. METHODOLOGY

This thesis will rely on information gained from the project office, specifically focusing on the logistics support, the engineering, and the test and evaluation sections. Due to the

early stages of the IFCS upgrade, little actual test data will be available. In the analysis, many benefits of the upgrade, will be based on projections and preliminary test data available. Developmental testing is scheduled to begin in 1997.

F. BACKGROUND OF MLRS

In order to better understand the importance of upgrading this weapon system, a general knowledge of the system is required. The remaining sections in this chapter will give a general overview of MLRS, why it is becoming obsolete, and what is being done to ensure the system's continuing role in the Army.

The mission of the Multiple Launch Rocket System is to suppress, neutralize, delay, or destroy surface targets with indirect fires using rockets or missiles. The devastating fire

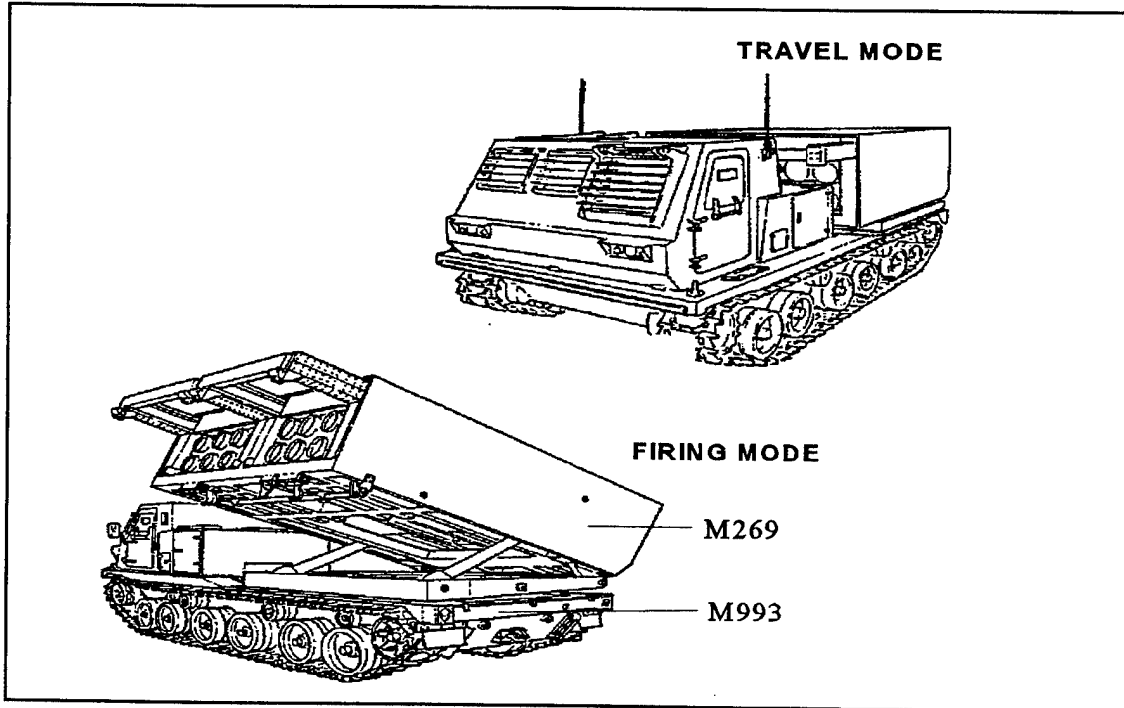

Figure 1-1 MLRS Configuration Modes M270 [Ref. 2, p. 2]

power demonstrated by this weapon system during operation Desert Storm is accurately described by the nick name given it by the Iraqi soldiers, "Steel Rain." This system is used for support fire to engage enemy troops, weapons, or positions that are threatening or can threaten friendly forces engaged in either offensive or defensive operations. The technique of "shoot and scoot" is used when employing this system operationally. The MLRS will normally deploy in platoons consisting of three launchers which are under the control of the firing battery headquarters. The platoon will normally operate in an area 2.5-3 km in diameter and use as many as nine firing points. The platoon operations area is usually located 5-10 km from the Forward Line Of Troops (FLOT). The launchers normally maintain hide positions away from their firing points until a fire mission is assigned. Once the fire mission has been assigned, the launchers move from their hide positions to their designated firing points where the mission is conducted. [Ref. 1, Vol 2 p.74]

Figure 1-1 depicts the weapon system in both a travel and firing mode. The MLRS system known as the M270, consists of the M269 Loader Launcher Module (LLM) mounted on an M993 Carrier. The M993 Carrier is a modification of the M2/3 Bradley Fighting Vehicle System (BFVS) chassis and is managed by the Tank-automotive and Armament Command (TACOM) located in Detroit, Michigan. The carrier is manufactured by United Defense Limited Partnership (UDLP), formerly FMC Corp. The system was originally produced in San Jose, California, but production was shifted to York, Pennsylvania in 1995.[Ref.2, p.2-4]

The loader launcher module is manufactured and assembled at Camden, Arkansas by the Loral Vought Systems Corporation. The LLM comprises three major components: the

cage, the turret and the base. The LLM is the actual housing and firing platform for the MLRS. The LLM also houses the fire control system (FCS) components and provides hydraulic power to operate the system's azimuth and elevation mechanisms. The LLM has the capability to perform self loading and unloading of munitions launch pod containers.

The cage assembly is made of 14mm aluminum armor which is designed to protect the system and the on-board munitions from enemy artillery fragments. The fire control components, booms, hoists and motors required for loading and unloading procedures are all contained within the cage assembly. Within the cage assembly are two bays for launch pod assemblies. The boom controller (BC), which operates the hoist and booms, is located behind an armored door on the left rear of the cage. The BC is a hand held device that allows a crewman to control the launcher during loading and unloading procedures.

The turret assembly is an aluminum structure that supports and attaches the cage assembly to the outer face of the azimuth drive gear bearing in the base assembly. The turret uses both mechanical and hydraulic power to raise and lower the cage assembly. The turret has a safety system built-in which holds the cage at the current elevation when hydraulic pressure drops below 495 psi.

The base assembly attaches the drive gear bearing and, ultimately, the cage to the bed of the carrier vehicle. Major components housed in the base include the azimuth drive speed reducer, hydraulic servo motor, hydraulic power supply, hydraulic swivel and the heat exchanger.

G. BACKGROUND OF FCS

This section narrows the focus to the Fire Control System (FCS), of MLRS. First I will explain the FCS in the current obsolete configuration. Then, in sections H and I of this Chapter I, will explain the upgrade and how the integration of BIT enhances the readiness of the system by enhancing the man-machine interface.

The MLRS has a Fire Control System (FCS) which provides communications processing, computations for ballistic solutions, data display, and interface between the soldiers and machine as necessary to select, control and accurately fire up to 12 rockets or two missiles singularly or in a preprogrammed sequence. Sensors in the FCS provide the crew with information on system failure or malfunctions. The FCS uses a solid-state microprocessor-based, command, control, communications and intelligence system. The system is designed to receive digital data from the Battery Fire Direction System (FDS) or manual data entered from the gunner, and process the information into a solution that provides aiming azimuth and elevation.

The MLRS FCS provides for the correct selection and sequencing of ordnance to ensure coordinated fire is focused on the designated target. The FCS consists of a Fire Control Panel (FCP), an Improved Electronic Unit (IEU), a Fire Control Unit (FCU), a Payload Interface Module (PIM), and a Boom Control (BC). Figures 1-2 and 1-3 show the LRUs that comprise the current FCS in the MLRS. [Ref. 2, p.11-14]

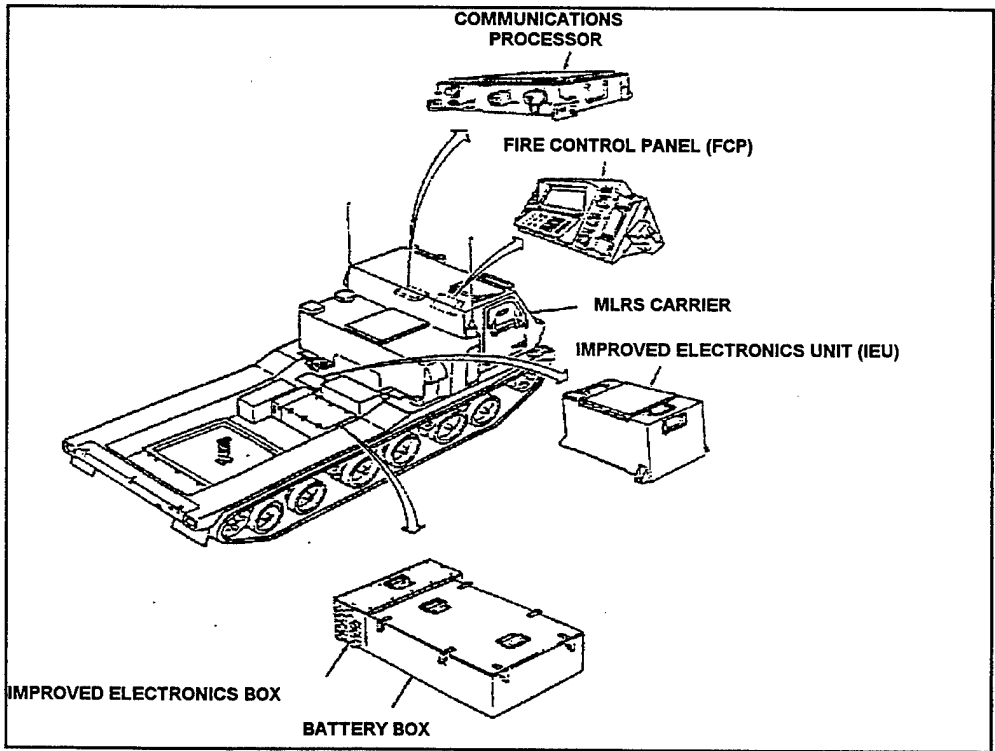

Figure 1-2 M993 Mounted LRUs [Ref. 2, p.12]

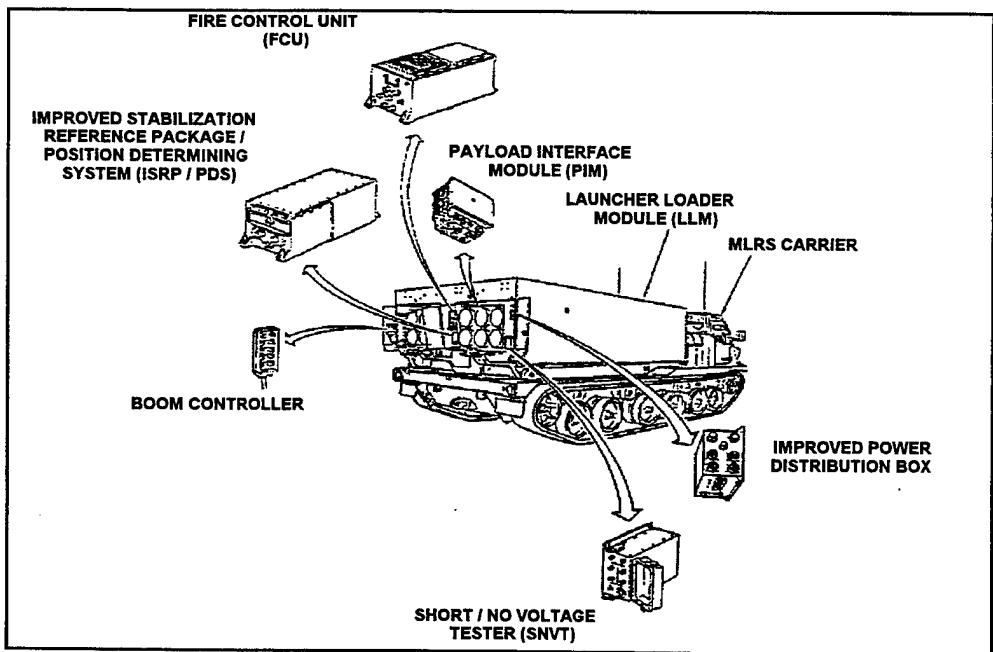

Figure 1-3 M269 Mounted LRUs [Ref. 2, p.14]

The fire control panel (FCP) serves as the link between man and machine. The FCP allows the operator to manually or digitally load firing solutions into the computer. Through the FCP, the operator is able to perform loading, firing and communications internal and external to the vehicle. The FCP has a 25 key keyboard; twelve keys are for entering numerical data and the remainder are used for selecting operational modes. The keyboard also has five LRU fault indicator lights. The FCP has a plasma panel that can display up to seven rows of text. Messages pertaining to fire missions, communications and basic fault warnings can be displayed on this panel. [Ref.3]

The Improved Electronics Unit (IEU) is the computer and memory for the FCS. This part of the system calculates the technical data necessary to conduct each fire mission. The IEU also works in conjunction with the BC in conducting loading and unloading operations. The improved stabilization reference package (ISRP) provides the IEU with precise location and direction of the launcher for calculating firing solutions. The IEU has Bulk Memory Storage Units (BMSU) which allow the system to be programmed in the field using a Program Load Unit (PLU). The PLU is a portable unit which inserts software modifications and upgrades to current software editions directly into the deployed launcher. The IEU accepts software upgrades without the need for changing the hardware. This expandable memory allows for improvements in current munitions and for fielding of future, more advanced munitions.

The Fire Control Unit (FCU) serves as the link between the IEU and the ISRP, rocket pods, launcher drive system (LDS), boom and hoist actuators, and the BC. The FCU transforms digital data

from the IEU into analog output to operate the launcher's electrical devices. It also converts analog input from the launcher's electrical devices into digital output for use by the IEU.

The payload interface module (PIM) serves as the interface between the launcher, Improved Electrical Box (IEB), IEU and the onboard munitions. It provides power and pre-flight programming information to the on board munitions.

The boom controller (BC) is a hand held device with nine meters of cable connected to the FCS. This allows the crew to control the vehicle azimuth and elevation while outside of the carrier. The BC is used when crewmen are conducting loading and unloading operations.

The MLRS was originally designed in the mid-1970's to defend our European allies against the numerically superior Warsaw Pact forces. The full scale production contract was awarded in December 1982. Since the system's inception, the launcher has undergone many modifications and improvements in maintainability factors. However, the fire control system is still based on early 1980's digital and analog technology. The Intel Z80, 8080, and 8088 microprocessors used in the system have reached their maximum capacity. As a result of this, the existing FCS is considered obsolete and must be upgraded. This upgrade will be accomplished with the fielding of the improved fire control system (IFCS). [Ref.4]

H. BACKGROUND OF IFCS

This section will outline the improvements being made in the FCS and will compare the capabilities of the old FCS and the new FCS. This section will introduce the use of BIT, and the significance of BIT on improving the systems readiness.

The purpose of the IFCS in the MLRS is to provide command and control, interface between the crew and the machine, and a weapon/launcher interface, which is critical to direct and control the M270 launcher. This system provides for accurate firing of the weapon and ammunition loading operations for both rocket and missile type munitions. In addition to providing command and control of the launcher during firing and loading operations, the IFCS, through the use of a Global Positioning System (GPS), provides the crew and the fire control system with accurate vehicle location. There are six line replaceable units (LRU) that compose the IFCS. These LRUs consist of Position Navigation Unit (PNU), Launcher Interface Unit (LIU), Weapon Interface Unit (WIU), Meteorological sensor (MS), Fire Control Panel (FCP), and Power Switching Unit (PSU). Figure 1-4 shows the LRUs in the IFCS. [Ref. 2, p. E7-E8]

The position navigation unit (PNU) is a microprocessor unit which provides the LLM with attitude and heading reference measurements and vehicle position determination. The system uses a self-contained GPS receiver and antenna to obtain this information. The PNU acquires data from satellite up-link and determines the vehicle's position in three-dimensional Universal Transverse Mercator (UTM) grid coordinates and also in standard latitude and longitude coordinates. The PNU provides the IFCS with azimuth heading from north and elevation angle from the true horizontal plane.

The launcher interface unit (LIU) is the electronic means linking man and machine. The LIU provides command and control of the launcher, general purpose processing, system power management and communication interface with the IFCS.

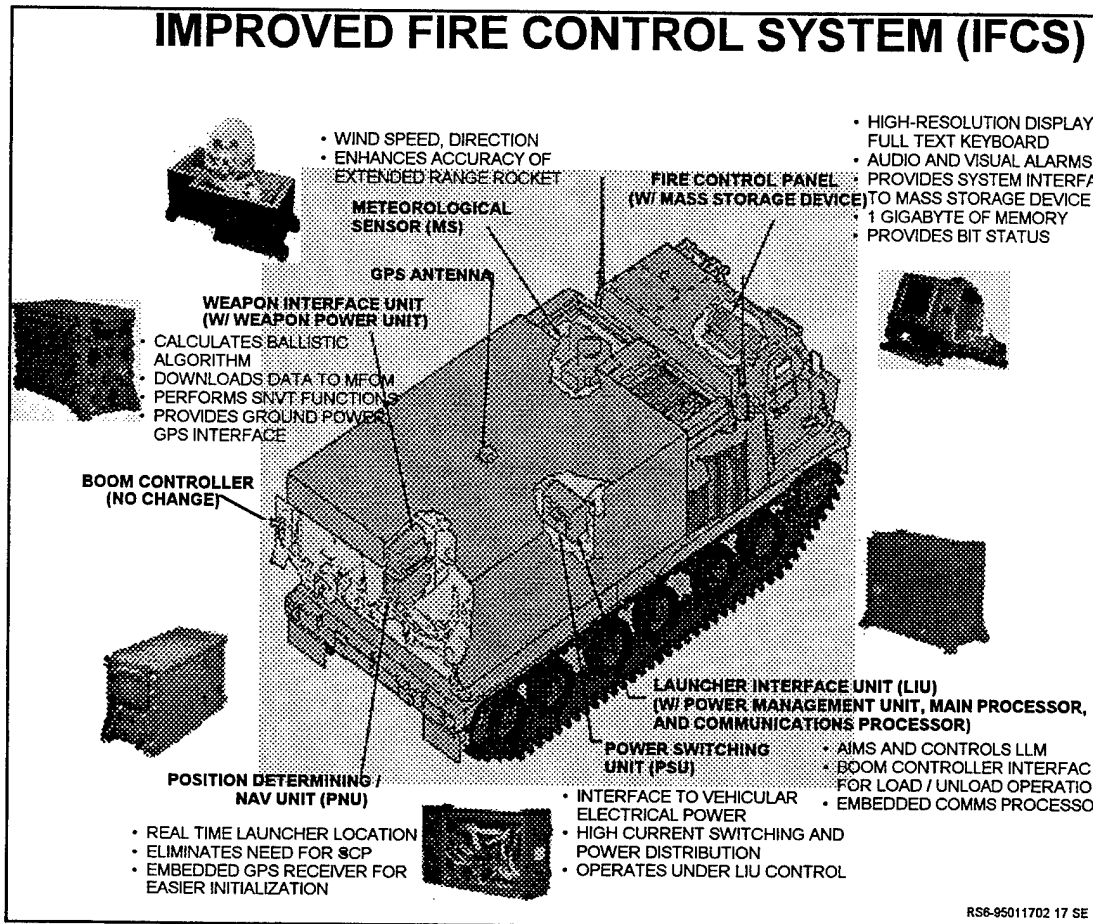

Figure 1-4 IFCS [Ref. 2, p. E- 13]

The weapon interface unit (WIU) provides the IFCS with the ability to communicate with the onboard munitions. This interface allows the IFCS to communicate and process information to and from the MLRS family of munitions (MFOM) that are currently being upgraded and developed. The WIU interacts directly with the warhead/missile providing it with pre-flight programming, time sequencing, pre-flight system checks and provides power to the weapon.

The meteorological sensor (MS) provides the IFCS with local wind speed, wind direction, and current local temperature. This information is used in the computation of firing solutions for the onboard munitions.

The fire control panel (FCP) provides the link between the crewman and the IFCS. This control panel is used to process manual and digital firing information to the launcher. This panel also enables the crew to monitor all on board systems and to conduct system checks. This panel will provide the crew with information from the system's built in test (BIT) about system failure and warning of potential failure.

The power switching unit (PSU) provides the IFCS with power. The system also performs high current switching power distribution functions and monitors voltage and current status. This system is controlled by the LIU and responds to commands to conduct various power switching procedures within the vehicle and in powering the onboard munitions.

The IFCS is a major system enhancement of the current MLRS. The new design uses common hardware, software and standardized interfaces. The concept is to provide a system that is modern and upgradeable to changing technology. The use of the BIT is the essential element in improving the systems readiness. The improvements in the IFCS over the current FCS are shown in Figure 1-5. [Ref. 2, p.E-12]

I. BACKGROUND OF CURRENT MAINTENANCE SYSTEM

The Army's maintenance system traditionally consists of five levels. Each level serves a specific purpose within the system. The maintenance levels are: Operator/Crew, Organizational, Direct Support (DS), General Support (GS), and Depot. These levels will be

defined below. The main deviations to this maintenance system occur in the aviation community and for other low density, high technology items. [Ref. 5, p.5-6]

PARAMETER	CURRENT LAUNCHER	LAUNCHER WITH IFCS	IMPROVEMENTS
MAIN PROCESSOR	3 EA Z8001@ 6MHz 1EA Z80 @ 2 MHz	8 EA 486DX @ 32MHz	INC GROWTH RESERVE
BULK STORAGE MEMORY	2 MEG	1 GIG	INC GROWTH RESERVE
BACKPLANE	16 BIT NONSTANDARD	32 BIT STANDARD VME	FLEXIBILITY FOR UPGRADE
BUS CHARACTERISTICS	6 19.2kb/s RS-232 CHANNEL	ETHERNET AND REDUNDANT MIL-STD-1553B	INC CAPACITY AND FLEXIBILITY
COMMUNICATION CAPABILITIES	1 FSK CHANNEL	2 PROG CHANNELS AND 1 X .25 CHANNEL	FLEXIBILITY FOR UPDATE CHANGES
POSITION NAVIGATION	.5 SECANT LAT MIL AZIMUTH ACCURACY 7.5-MIN COLD START 20-M POS ACCURACY	.375 SECANT LAT RMS MIL AZIMUTH ACCURACY 5-MIN COLD START/MOVING BASE ALIGN WITH GPS 10-M POSITION ACCURACY WITH GPS AS AN AID	INC LONG RANGE ACCURACY, 2.5 MIN FASTER REACTION TIME
FCP DISPLAY	TEXT ONLY, 160X320 PIXELS	GRAPHICS HARDWARE CAPABILITY AND TEXT, 640 X 480 PIXELS	INC EXPANSION CAPABILITY, IMPROVE MAN/MACHINE INTERFACE
FCP KEYBOARD	DEDICATED FUNCTION KEYS NOT LIGHTED NO ALPHA KEYS	PROGRAMMABLE FUNCTION KEYS DIMMABLE BACKLIGHT FULL ALPHA KEYBOARD	INC EXPANSION CAPABILITY, IMPROVE MAN/MACHINE INTERFACE
WEAPON INTERFACE	19.2-KB/s RS-423A 24A POWER PER LAUNCH POD	ETHERNET, REDUNDANT MIL STD 1553B, RS-423A 50A POWER PER LAUNCH POD	INC GROWTH CAPACITY, + 26A WEAPONS POWER
WIND MEASUREMENT	REQUIRES EXTERNAL DATA SOURCE	MEASURES WIND VELOCITY & DIRECTION 100m ABOVE LAUNCHER	CURRENT DATA, 30-40 % BETTER FOR EXTENDED RANGE ROCKETS

Figure 1-5 IFCS Comparison Summary [Ref. 2, p. E-12]

The operator/crew level of maintenance consists of performing preventive maintenance checks and services. Crewmen perform before, during and after operations checks, authorized adjustments, preventive maintenance, and minor repairs which are outlined in the Maintenance Allocation Chart (MAC), Technical Manual 9-1425-646-20. The operator/crew will monitor the system and, as faults are discovered which exceed their capability, they will request maintenance assistance from the organizational mechanic. Operator/crew perform all maintenance tasks both in garrison and field locations.

Organizational maintenance consists of fault isolation to the module/assembly using Standard test equipment (STE). The mechanic is authorized, based on the MAC (TM 9-1425-646-20), to remove and replace some components, perform lubrication, system services and minor adjustments. The organizational mechanic monitors the system and, as faults are discovered which exceed his capability, he requests maintenance assistance from Direct Support Maintenance. The organizational mechanic performs all maintenance tasks both in garrison and field locations.

Direct Support (DS) maintenance consists of fault isolation of equipment, components and assemblies using special test equipment. The DS mechanic replaces minor and major components to effect repair of the end item. He performs all maintenance tasks in both garrison and field locations. Faults that exceed the DS level authorization in the MAC (TM 9-1425-646-20) or exceed the capacity of the DS unit are sent to the General Support (GS) level.

General Support maintenance has the same capability as the DS mechanic plus additional capability to fault isolate, calibrate and repair certain line replaceable units (LRUs), circuit card assemblies (CCAs), heavy body, hull, turret and frame repair. Mechanics at level perform maintenance that requires more time and in-depth maintenance. The GS unit is manned with ten percent more soldiers than their primary mission requires in order to perform backup DS support for divisional and corps units. The GS mechanic performs diagnosis and fault isolation in the equipment, component and assembly down to the internal piece part level. The mechanic also performs repair/modification of the end item, component, and assemblies to the internal piece part level. The GS unit works in a fixed facility in garrison, and based on requirements in Field Manual 43-20 must have the ability to perform all tasks in field conditions. In reality most frame, and heavy body, hull or turret repairs are not feasible in field conditions. Maintenance which exceeds the GS capability is sent to the Depot. [Ref. 16, p. 1-2]

Depot maintenance consists of overhaul of end items, components and assemblies requiring manufacturers' tolerances. The depot is a fixed facility with special test equipment and tools. The depot's primary missions are: retrofit, rebuild and major modifications to extend the operational life of the end item. These maintenance functions are performed at industrial-type facilities operated by the DoD or contractor.

J. MLRS CURRENT MAINTENANCE CONCEPT

The current maintenance concept used to support the MLRS considers Operator/crew and organizational maintenance as one combined level. Direct support, general support and depot level maintenance remain separate, distinct functions. The process begins when a fault

occurs on the launcher. The crew is alerted to the fault by a flashing light and/or a basic message on the fire control panel. This light or message provides limited information beyond recognizing a fault or failure and identifying which component. At times unwanted power or voltage changes occur which will cause the FCS to react to false internal signals. Fault prompts may be displayed on the plasma panel or fault indicator lights may be illuminated when there is no actual malfunction. The crew must begin trouble shooting the launcher to determine what the problem is, that it is not a false signal, and if the mission can be continued or if they can repair the system. If the fault is serious, any operations will stop automatically. If the fault is not serious, the operation may continue. [Ref. 6]

If the MLRS crew (Military Occupational Specialists 13M), who are trained to perform both operator and organizational level maintenance, are able to identify a faulty LRU, they may be able to repair the launcher by replacing the defective LRU. A serviceable LRU must be brought to the location of the launcher from the battery combat support trains, where supply personnel maintain the unit's repair parts stocks. The distance between the unit's repair parts stocks and the downed launcher varies depending on the tactical situation but could be as much as 10-15km or as little as one kilometer.

If the MLRS crew determine that the repair is beyond their capability or that they are unable to isolate the fault, they will request assistance from the supporting direct support maintenance unit. Two direct support mechanics (Military Occupational Specialist 27M) are normally attached (as a contact team) and provide direct support maintenance for a platoon of three launchers. The DS mechanics accompany the MLRS platoon as they move

on the battlefield. The DS mechanics have their own separate vehicle which contains the tools and test equipment they use to support the MLRS platoon.

The DS mechanics conduct diagnostic testing on the downed launcher. This troubleshooting includes the same test performed by the MLRS crew, plus additional tests as outlined in the -30 level (DS level) technical manual. The Bay Shop Test Facility (BSTF), which is a vehicle mounted version of the Integrated Family of Test Equipment (IFTE) and is located at the DS maintenance company can be used to conduct more detailed troubleshooting. The DS mechanic will repair the launcher using the MLRS battery's repair part stock of LRUs.

Defective LRUs discovered by either the MLRS crew or the DS mechanic are turned into the supply system at the direct support unit. The faulty LRUs are then sent to the supporting general support maintenance company where a calibration technician (Military Occupational Specialist 35Y), troubleshoots to isolate the fault in the LRU using test equipment. The defective LRU is then repaired and returned to the supply system. Defective circuit cards removed from the LRU are sent to the Depot for repair or discard. Under the current repair concept only the general support company and the depot can repair LRUs. This concept will change with the integration of the improved fire control system.

K. MAINTENANCE CONCEPT WITH IFCS

The maintenance concept that will be used with the IFCS will push more diagnostics and repair capability forward. The new concept is illustrated in Figure 1-6. Under this concept, the repair process will still begin with the crew/operator of the MLRS. The improved automated diagnostic BIT will provide the crew with detailed information regarding

the maintenance condition of the launcher. The detailed information is provided to the crewman via the computer screen of the FCP. This information will give specific details about the exact fault. The goal of the system is to report faults with a 95% accuracy and

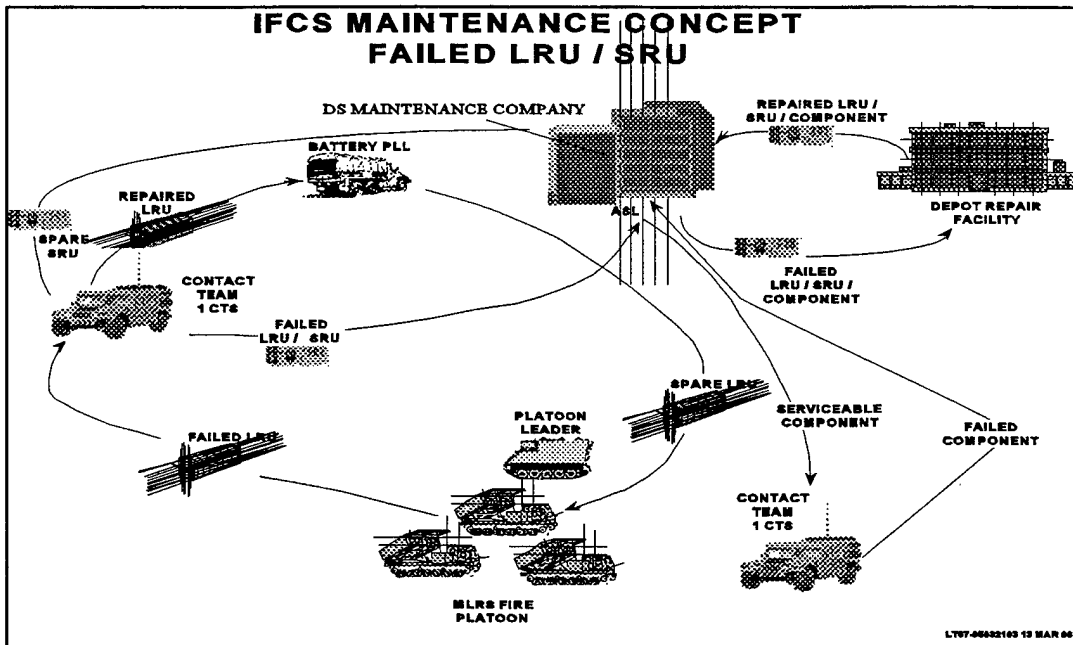

Figure 1-6 IFCS Maintenance Concept [Ref. 2, p. E-35]

with a maximum of 6% false failure indications. The accuracy rate for fault isolation is specified in the contract. The BIT will monitor all electronic systems on the launcher. [Ref. 4]

Once the crew receives a fault message from the BIT, the computer will advise the operator of the severity of the fault and provide information on the current capabilities of the launcher. With this information the MLRS crew will determine if the mission can continue or if maintenance must be conducted. The fault message provided to the operator

will isolate the failure to the specific LRU. This will allow the crew to contact the battery's repair parts section of the unit's combat train to send the needed repair part to the location of the launcher.

When the crew has replaced the LRU, a Power On Self Test (POST) will validate the corrective action. If the system indicates no further problems, the faulty LRU will be collected at the battery's repair parts section, and forwarded to the supporting direct support maintenance company. If the POST indicates a new fault, the crew may continue maintenance procedures outlined above. However, if the POST indicates the same fault or a fault that exceeds the maintenance capabilities of the crew, assistance must be requested from the supporting DS contact team at the launcher site.

The DS mechanic will conduct diagnostic tests using the launcher's internal test capability. The DS mechanic will begin trouble shooting the launcher on site where the failure occurred. If there is no new fault indication the DS mechanic, he will use the Contact Test Set (CTS), with the appropriate augmentation equipment, to conduct an in-depth and thorough diagnostic test of the system. The CTS will replace the IFTE once the IFCS is fielded. Unlike the IFTE, each contact team will have a CTS. Once the fault is isolated, the DS mechanic will conduct the repair by replacing the faulty LRU with a serviceable one from the artillery battery's repair parts section (PLL). The DS mechanic will have the capability to isolate the faulty Circuit Card Assembly (CCA), within the LRU, using the CTS. The tactical situation will determine when, or if, the contact team has the time to repair the LRU or to send it to the supporting base maintenance company.

The CCA used by the contact team to repair the LRU is part of the DS unit's repair parts stockage (ASL). The supporting DS contact team will deploy with a predetermined stock of various CCAs. The number and combination of CCAs stocked by the contact team will be determined based on historical information and availability. The DS contact team will maintain an adequate stock of needed repair parts and will be supported by the parent DS maintenance company. Repair parts will be "pushed" to the contact team by the supporting parent company. If the DS mechanic is unable to repair the LRU, it will be submitted to the artillery unit's repair parts section. The faulty LRU is then forwarded to the supporting DS company for repair or disposition instructions. If the DS company is unable to repair the LRU, it will then be sent to the Depot for repair.

Faulty LRUs not repaired by the forward DS contact team will be sent to the supporting DS maintenance company for testing and repair. Replacement of CCA is authorized to be conducted by the forward DS contact team and/or the supporting DS company. Any LRU not repaired at the DS company will be sent to the Depot for repair. All defective CCAs will be sent to the Depot for testing and repair or discard. The Depot is the only repair level authorized to repair CCAs.

Under the new maintenance concept the General Support Company and the calibration technician (Military Occupational Specialists 35Y), is no longer needed and removed from the process. All capability previously performed by the GS company is conducted by the MLRS crew, DS mechanics, or the Depot. [Ref. 16, p.2-1]

L. SUMMARY

This chapter described the MLRS, the FCS, the evolution of the IFCS and the changes in the maintenance concept to support the IFCS. It also addressed the question of how BIT will improve the readiness of the FCS in the MLRS, the readiness of the system will be enhanced by the more efficient fault isolation capability of BIT, and how the capability of fault isolation which will enable the repair of the system far forward on the battlefield using fewer levels of maintenance. This chapter also provided background information about the Army's maintenance system and how it is used to support the current and future FCS in the MLRS. The following chapters will address specifics about the IFCS and how the system's readiness will be impacted with the use of BIT.

II. EVOLUTION OF THE BIT MAINTENANCE CONCEPT

A. INTRODUCTION

This chapter will review the factors that led to the Improved Fire Control System (IFCS) and the built in test (BIT) maintenance concept. Factors external to the obsolescence of the aging fire control system are a driving force in the application and use of BIT in the IFCS. The factors which have influenced the application of BIT are the changing National Doctrine and Military Strategy and how the Army logistically will support weapon systems on the battlefield into the 21st century.

Other factors driving the change to the BIT maintenance concept are the DoD and Army budget and force reductions. This chapter will review the Army budget and how reduction of funding has forced the logistician to seek ways, such as BIT, to keep readiness high while funding decreases. It will also discuss how the effects of reduction in forces will be eased by compressing the levels of maintenance using BIT. The final section of this chapter will discuss how readiness is affected with the implementation of BIT in the IFCS in the areas of: equipment, maintenance personnel, and logistical support unit internal structure.

[Ref. 9]

B. DOCTRINE AND STRATEGY

This section documents how changes in U.S. Doctrine and Strategy have caused significant modification in logistical support methods. This section also reviews the DoD's planned logistical support initiatives for the 21st Century Army. Understanding the doctrinal

and strategic roles of the Army, clarifies the significance of modernizing readiness. The BIT maintenance concept is a step by the logistician to introduce into current and future systems, a means to more efficiently maintain readiness.

Current doctrine and strategy have evolved due to the dynamic changes in the military's roles and missions since the end of the Cold War. This has been demonstrated several times; Operation Desert Shield/Storm, Operation Just Cause, and Bosnia are prime examples of the diverse missions the military now face.

In 1991, in response to the rapid changes in the international and domestic environment, the President published a new National Security Strategy for the United States. Shortly thereafter, the Chairman of the Joint Chiefs of Staff published the new National Military Strategy. Those two landmark documents, responding fundamentally to the changing threat and dramatic budget reductions, altered the structural and operational paradigms of all DoD components. [Ref. 7, p.2-1]

As a result the Army shifted from a forward deployed, European-based force to a United States-based, force projection Army. This shift caused a significant change to how the Army prepares, projects and logistically supports operations. The change in the National Military Strategy is consistent with the reduction in forces and also in budgetary reductions. The following sections will review the changes in the U.S. National Military Strategy and the budgetary reductions in the DoD and the U.S. Army. The information in these sections leads to a better understanding of how the use of BIT is an essential initial step in maintaining readiness in the turbulence of shrinking resources.

1. National Military Strategy

In the 1995 National Military Strategy, General John M. Shalikashvili stated that in response to the changing global situation the United States must enhance National security

by ensuring a strong and capable military, promoting cooperative security measures with other countries, working to ensure open foreign markets and to cultivate economic growth, and promoting democracy in the world. "Our Armed Forces are engaged worldwide on a continual basis to accomplish two national military objectives: promoting stability and thwarting aggression." To accomplish these two objectives, the military must perform three sets of tasks. These tasks are:

- Peacetime engagement.
- Deterrence and conflict prevention.
- Fighting and winning our Nation's wars.

Furthermore, achieving the "tasks of the strategy is facilitated by the two complementary strategic concepts of overseas presence and power projection." [Ref. 8, p. I] Understanding the National Military Strategy and the tasks which must be accomplished to achieve this strategy reveals the importance of maintaining the highest possible state of readiness. The U.S. military is charged with the tasks outlined above while simultaneously undergoing significant force and budgetary reductions. The requirements to maintain a U.S. based force projection military capable of carrying out the National Military Strategy has led to finding various means of more efficiently maintaining readiness. Implicit in our strategy is the importance of implementing logistics support concepts which improve readiness through efficiency, such as the BIT maintenance concept. [Ref. 8, p. i]

The U.S. Armed Forces have endured eight years of drawdown resulting from winning the "Cold War." The reduction in force along with the reshaping of the current force poses many challenges for the next century. Two examples of the challenges currently facing the

U.S. Armed Forces are: how to maintain readiness of aging equipment and, if necessary, support this equipment in two nearly simultaneous major regional conflicts. This smaller force will be enhanced by the selective fielding of modern weapon systems and selective upgrade and modification of current systems, but the Army is still struggling to do this within tightening budget constraints. The U.S. military's core requirements as outlined in the Bottom-Up Review demand a force which is capable of fighting and winning two major regional conflicts nearly simultaneously.

The forces that are charged with the responsibility to accomplish this are built on five fundamental principles. The first is the selection, retention and promotion of the highest quality men and women possible. The second principle is readiness. This is accomplished through developing joint doctrine, training, education and weapon system upgrades. The third principle consists of various force enhancement and improvement programs, such as the application of the BIT maintenance concept. The fourth principle is the selective modernization of essential weapon systems. This is also an essential part in the process to ensure future readiness. The fifth principle is that of balance. Despite the smaller size, the military must maintain the appropriate mix of forces and capabilities to provide the versatility to meet the requirements of the current strategy.

This section has shown how the 1995 National Military Strategy has impacted how the logistician will maintain a ready force. The tasks the military must perform can only be achieved by balancing quality personnel and some equipment modernization with the implementation of more efficient readiness concepts such as BIT, into current and future systems.

The next section will review the logistical initiatives to maintain readiness and accomplish the tasks of the National Military Strategy. The role of the BIT maintenance concept will also be shown.

2. Logistics

With the changes in the National Military Strategy that have occurred since the collapse of the Iron Curtain, Army logisticians have developed a new concept to support the requirement of the changing battlefield. The new logistics concept is part of *Force XXI*. This new logistics doctrine focuses on mobility at the strategic and tactical levels, supply distribution, and sustainment and readiness initiatives that accompany the evolving operational doctrine and military strategy. The plan to achieve the goals outlined in *Force XXI* involve three phases: near term (1994-1996), midterm (2002), and a long term (2020).

During the near term phase many new logistics concepts have been introduced into the current Army structure. *Force XXI* structure characteristics include:

- Battle command awareness based on real time information shared at all levels.
- Digitally linked units and weapons systems. Part of this is the integration of the BIT maintenance concept into the upgrades of current weapon systems (MLRS and Patriot).
- Task organized force structures providing greater flexibility to respond to specific enemy threats. Compression of maintenance levels from four to three streamlines the logistics element of the task force. This is possible through the use of BIT.
- Seamless logistics. Repair of LRUs far forward on the Battlefield is one aspect of seamless logistics and is a benefit of the implementation of the BIT maintenance concept.

The midterm phase of this plan will introduce new force structures into the current Army system such as Brigade 96, Division 97, and Corps 99, and complete the implementation of the *Power Projection Logistics* initiatives started in the early 1990's. These initiatives include: pre-positioned maintenance facilities afloat, Army Strategic Mobility Plan (ASMP), and total asset visibility (TAV) which will reduce repair part stockage levels and enhance seamless logistics. [Ref. 7, p.2-1]

The third phase of the plan will introduce *Battlespace Logistics*. The concept is to develop a logistics system that is flexible, and usable in wartime while sufficiently efficient in peacetime. The characteristics of the *Battlespace Logistics* are:

- A single comprehensive system that meets the needs of the entire Army. This system will fully synchronize and standardize the active and reserve components, including the combat arms, combat support and the combat service support units. This system will also be compatible with joint or combined force operations.
- A single system that is linked electronically and will provide accurate, usable real-time information including total asset visibility (TAV).
- A cost-effective, non-hierarchical support structure, transparent to the user consisting of multifunctional components. [Ref. 7, p. 3-5]

The Army needs a flexible, responsive maintenance concept to support future operations. The use of the BIT maintenance concept is one initiative that is currently being studied and applied to current and developing systems.

Changing U.S. Doctrine and Strategy is driving the Army to reinvent logistics support for the 21st Century Battlefield. This section has highlighted readiness challenges that Army logisticians must find answers to. One of the initiatives to maintain a high state of readiness

is the use of the BIT maintenance concept. The application of BIT is an efficient way to maintain readiness while forces and funding are being reduced.

The following section will cover how budgetary reductions have forced the logistician to find ways to maintain readiness with less money. Budget reductions are also a driving force for the development of the BIT maintenance concept, while at the same time constraining the effort.

C. BUDGET REDUCTIONS

1. DoD Budget

Table 2-1 shows the Defense budget trends from 1990-1997. Over those years, excluding 1991 and 1992 for Operation Desert Shield, the DoD budget has decreased each year in constant dollars. Not shown but also true, the DoD budget as a percentage of the overall federal budget has also decreased.

Fiscal Year	Current Dollars (Billions)	Constant FY 97 Dollars (Billions)	Real Growth Percentage
1990	293.0	352.7	-2.2
1991	276.2	317.5	-10
1992	281.9	318	.2
1993	267.4	292.8	-7.9
1994	251.4	268.8	-8.2
1995	255.7	268.1	-.3
1996	251.8	258.1	-3.7
1997	242.6	242.6	-6

Table 2-1 Department of Defense Budget Authority [Ref. 11, p.252]

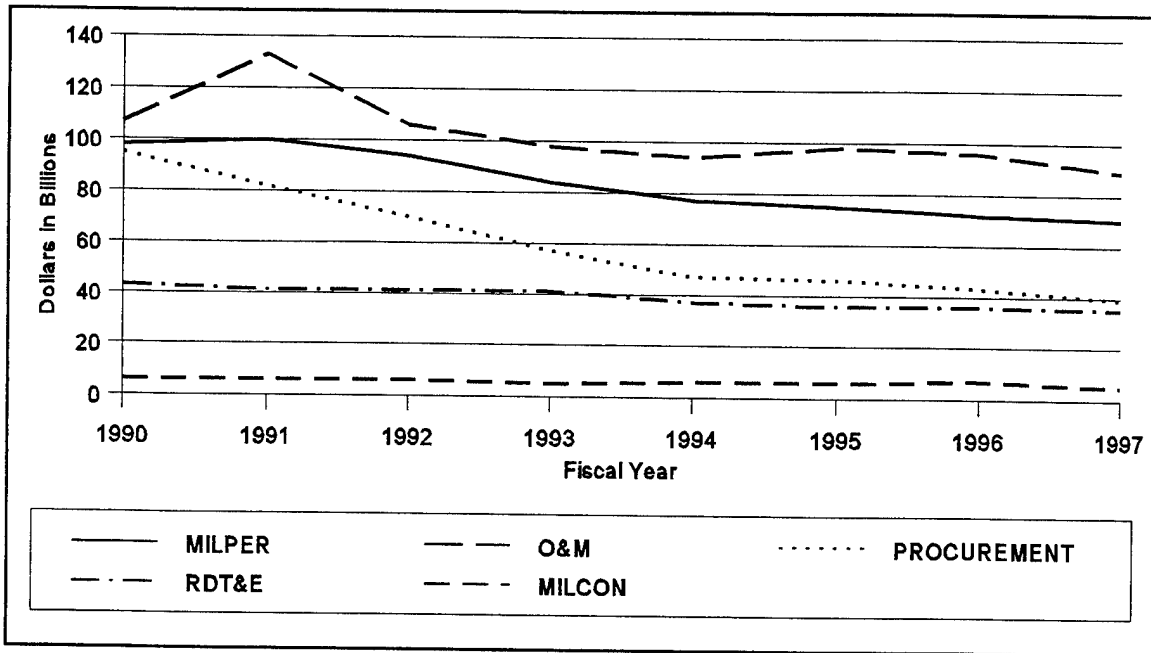

Figure 2-1 DoD Budget Authority by Appropriation [Ref. 11, p. B-1]

These reductions reflect heavily in the operational and maintenance area (O&M) and procurement as shown in Figure 2-1. The O&M increase in FY 1991 and 1992 reflects incremental increases due to Operation Desert Shield and receipts from allied contributions. O&M reductions have directly affected the Army's support structure.

The O&M appropriation is typically viewed as discretionary and is targeted first when funding reductions are needed. O&M funds are used to purchase all repair parts, fuel, and service parts. O&M expenditure is also affected by OPTEMPO (Operational Tempo) of the military. Unplanned operations, such as Somalia or Haiti, are financed from the O&M appropriation, leaving less money to logistically support the rest of the Army. These budgetary reductions in O&M and procurement have forced the Army to find ways to maintain readiness with less funding; this has been a driving force in developing BIT.

RDT&E, procurement, and O&M funds must be used to develop, acquire, and field BIT. Finding funds for BIT is a challenge in the current fiscal environment.

2. Army Budget

The Army's budget reflects the reductions that have occurred in the DoD. The Army has experienced reductions in both total obligation authority (TOA) and outlays. Figure 2-2 illustrates the past seven years' TOA and outlays. The increase in 1991 was due to Operation Desert Shield.

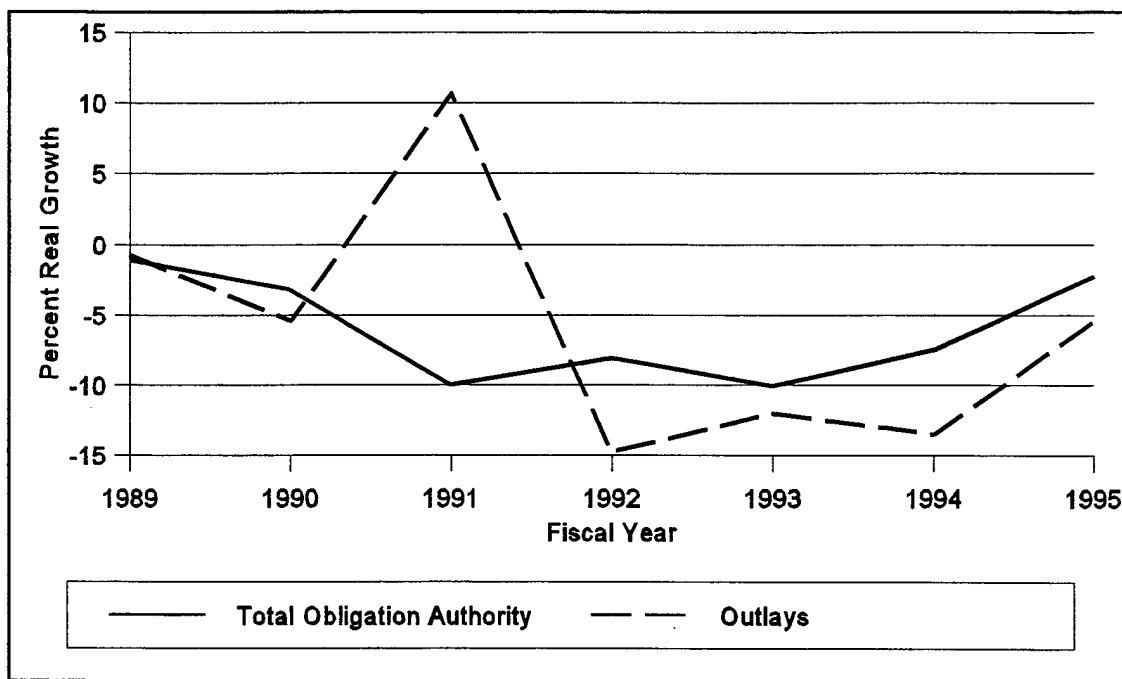

Figure 2-2 Army Real Growth Percentage [Ref. 11, p. B-1]

The Army's budget is divided into appropriation bills. The following are the Army's top five appropriations: military personnel (MILPERS), operations and maintenance (O&M), procurement, research and development (RDT&E), and military construction (MILCON). Figure 2-3 shows how the funds were apportioned in FY 94 and FY 95; the percentages are

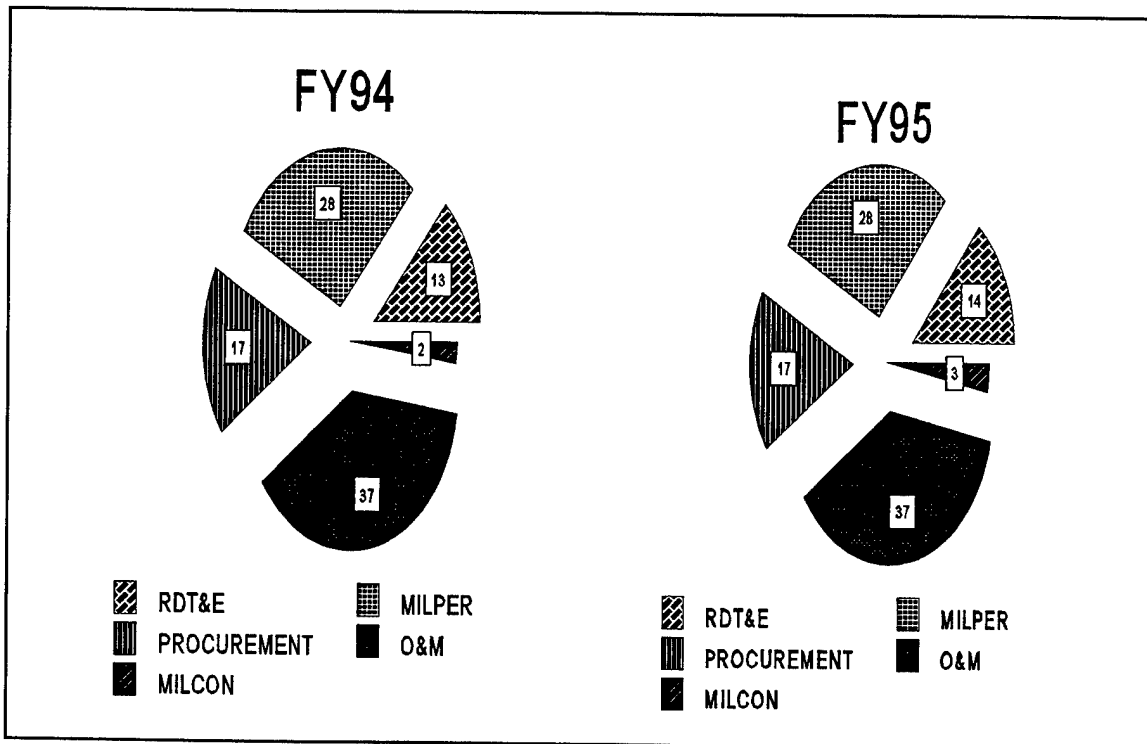

Figure 2-3 Army Budget by Appropriation [Ref. 11, p. B-1]

percentages are typical. O&M is usually targeted first along with procurement when reductions must occur. This fact emphasizes the importance of more efficiently using the O&M funds. Figure 2-4 shows the Army's budgetary outlays by appropriation during FY 1993-1995 and demonstrates how O&M funding has decreased.

The O&M appropriation is subdivided into four separate categories called budget activities (BA). Table 2-2 provides a description of the types of funds within the budget activity. With the reduction in O&M dollars, the logistician must find efficiencies to ease the pressure. Use of BIT contributes to more efficient and effective diagnostics, resulting in O&M savings. The 1995 fiscal year procurement budget was approximately one third of the procurement outlays during fiscal year 1986. The downward trend continued in the 1996

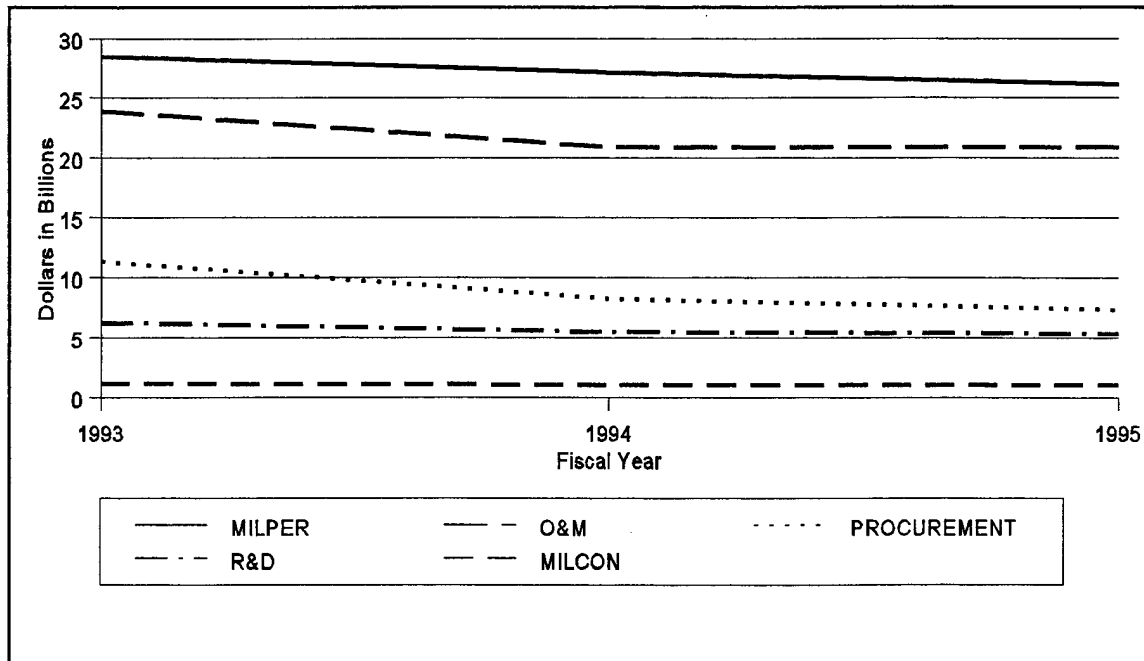

Figure 2-4 Army Outlays by Fiscal Year [Ref. 10, p. 7]

Budget Activity (BA)	Description of Funding within the BA
BA 1- Operating Forces	Finances the mission essential day-to-day operations of the active component forces.(i.e., combat units, tactical support, base operations and depot support)
BA 2- Mobilization	Supports strategic mobilization requirements, prepositioned supplies and equipment, and Army Reserves.
BA 3-Training and Recruiting	Finances institutional training and other selected training support activities.
BA 4- Administration and Service-wide Activities	Funds administrative, logistics, communications, and other Army-wide support functions to secure, equipment, deploy, transport, sustain, and support forces worldwide.

Table 2-2 Budget Activities within O&M Appropriations [Ref.10, p.32]

fiscal year with a budget that reduced the planned procurement fund by one billion dollars. These reductions in procurement dollars make it difficult to buy and field needed new or upgraded equipment.

As equipment ages and approaches obsolescence the cost to maintain the equipment grows and demands a higher share of the O&M dollars. Yet increased O&M funding, other than for adjustments in inflation, has not occurred since fiscal year 1992. An answer to the O&M squeeze is to spend procurement dollars for new equipment; however, procurement dollars are more scarce than O&M. Therefore, the Army is trying to upgrade old equipment to relieve O&M pressures at less cost than new systems.

Specific costing information will be covered in Chapter III of this thesis. The basis of the cost savings will come from the increased efficiency of the BIT and the improved LRUs. The use of the BIT will allow reduction in the maintenance levels from four to three, through the elimination of general support calibration technicians in support of the MLRS. The BIT will enhance readiness by improving diagnostics and leading to system repair far forward on the Battlefield. This will also reduce the amount of repair parts required to support the system.

In summary the Army desperately needs to develop a system that will help the logistician accomplish readiness objectives while surviving reductions in budgetary support. The development and implementation of BIT technology and its increasing efficiency in diagnostics will help to maintain readiness levels while reducing O&M expenditures.

D. READINESS GOALS AND OBJECTIVES

1. Introduction

This section will introduce and explain the areas that influence readiness. These areas are equipment, maintenance personnel, and logistical support unit internal structure. The complex subject of readiness requires careful balance between the human and machine interface. BIT improves the interface between the crew/repairman and the weapon system.

2. Defining Readiness

Maintaining readiness is an essential component in virtually all of the Department's activities. In general terms, readiness is the overall ability of forces to arrive on time where needed and to be prepared to effectively carry out assigned missions. The ability of units to be ready on time to carry out their missions, in turn, is a function of having the equipment, supplies, logistics, intelligence, and experienced people with the skills to accomplish assigned tasks. [Ref. 11, p.24]

The general concept of readiness is easily understood. However, after close review, the complexity of the structure is revealed. This complex structure is composed of the following areas; organizations, resources, people, professional education, training, and leadership. Within this structure the Army must train, maintain, and sustain the force to accomplish the goal of the U.S. National Military Strategy.

The Department of Defense must manage readiness to accomplish the objectives in the National Military Strategy. In order to accomplish this, the Department must understand, measure, assess, and project readiness requirements on a variety of levels. The keys to success in managing this complex set of interactive tasks are to identify policy, budget, and operational levers that are essential to ensure readiness for current and future operations.

Readiness remains the Defense Department's highest priority. This area constitutes the most critical part of current and future military preparedness. [Ref. 11, p.23]

Having forces that are ready to fight requires an appropriate force structure, modernized equipment, maintenance and logistics support, and the requisite trained and motivated personnel. A deficiency in any of these elements can hurt readiness, inhibiting the timing of deploying forces, and thereby resulting in a readiness gap. In managing readiness, the Department strives to maintain a delicate balance of all crucial elements to ensure that forces arrive on time and are fully capable to meet mission demands. [Ref. 11, p. 25]

The importance of maintaining the U.S. military at the best possible readiness requires the application of the best maintenance concepts. The integration of BIT into current and future systems is a step to improving maintenance efficiency and assisting in achieving the readiness requirements.

3. Equipment

This section will review the importance and difficulty of maintaining equipment readiness. It will also outline initiatives underway to combat obsolescence and integrate BIT into modernization of current weapon systems.

The Army's established equipment readiness goal, as outlined in Army Regulation 220-1, states that all combat equipment will be maintained at a 90 percent readiness level. This means that all weapon systems must be fully operational and capable of performing their designed mission at a minimum of 90 percent of the time. Commanders and maintainers at all levels use this as a means to measure readiness and to evaluate subordinates' proficiency at ensuring combat capability.

Due to the growing age of the military's equipment, this 90 percent readiness goal/objective is becoming more difficult to achieve. As the systems age many repair parts become obsolete or unobtainable because designs change to accommodate technology improvements or simply because the manufacturer of the component or part goes out of business. Coupled with aging equipment, the recent emphasis on reducing repair part inventories, resulting from the operations and maintenance funding pinch discussed in the last section, has also compounded the difficulty in maintaining combat systems at the required 90 percent readiness level.

Even with the funding reductions in procurement and RDT&E, the DoD has undertaken an initiative to ensure military readiness well into the 21st century. This plan calls for the modernization of U.S. forces with a few new systems but mainly upgrades to existing systems to ensure that the American military continues to have technological and qualitative superiority on the battlefield. "Over the next several years, DoD will begin a recapitalization of U.S. forces which will be critical to the readiness of U.S. forces in the next century." The plan projects that in FY 2001, the procurement funding will increase to 60.1 billion dollars. This plan would be a 41 percent increase in real terms over the 38.9 billion dollars requested for FY 1997. [Ref. 11, p. 255]

The following are priorities in the plan:

- Precision-guided bombs and other crucial enhancement for long-range bombers plus other advanced munitions, especially ones for defeating enemy tanks. [Ref. 11] BIT will interface with the new Brilliant Anti Tank (BAT) and the Extended Range munitions used in MLRS. [Ref. 11]
- Surveillance systems such as Joint Surveillance Target Attack Radar System (JSTARS), unmanned aerial vehicles, and Spaced-Based Infrared Systems.

- For several tactical missiles systems, improvements to achieve greater accuracy and lethality. [Ref. 11, p. 255] The BIT concept will monitor and help maintain the Army's Tactical Missile (ATACM) used with MLRS.
- Theater missile defense through new systems like Patriot Advanced Capability-3, and Theater High-Altitude Area Defense (THAAD) systems.

The Department of Defense modernization/recapitalization plan is the result of intense assessments by many highly experienced defense leaders. They have produced a balanced, prudent plan to ensure the long-term readiness of U.S. forces well into the 21st century. [Ref. 11, p. 255]

This section has indicated the difficulty in maintaining readiness of Army equipment. It has also shown how BIT will be selectively integrated into current and future systems to improve the efficiency of the maintenance system. The improved efficiency by using BIT is one method to maintain readiness requirements.

4. Maintenance Personnel

This section reviews the key role maintenance personnel play in readiness. These personnel must be high quality, highly trained, motivated and retained to use the advanced technology systems, such as BIT, in the operation and maintenance of modern weapon systems. The application of BIT will make the mechanic a more valuable tool in the maintenance system. The use of BIT will reduce repair time and free the mechanic to perform other tasks.

The experiences during Operation Desert Shield/Desert Storm confirmed the fact that there is no substitute for high quality personnel in the military. With the military force becoming smaller each year, the diverse requirements of the services put an increasingly greater burden on the personnel structure. To reap the benefits of technological sophistication of the systems used in today's military, the quality of personnel must remain high.

The requirement for quality personnel reflects the reality of modern military operations. "Despite intense planning and high technology, military operations are nevertheless marked by ambiguity, uncertainty, and chance, and are driven by emotion; they normally continue 24 hours a day, in any conceivable terrain or climate, and in conditions of extreme stress." [Ref.8, p.18] With these conditions, leadership, courage, initiative, flexibility, and skill will remain essential to victory. Advances in technology will not replace the importance of high quality personnel in the military but will augment and improve capabilities.

Maintenance forward will reduce equipment downtime. The reduction in levels of maintenance will reduce repair parts stockage levels, storage costs, transportation, and handling costs. The efficiencies gained by using BIT and the associated cost savings will be covered further in Chapter III.

This section shows the critical role the soldier performs in accomplishing readiness requirements. The full benefit of advanced technology such as BIT, is dependent on quality soldiers. The advanced systems are only as good as the soldiers who use them; therefore, the Army must continue recruiting, training, and retaining the best quality soldiers possible.

This section has addressed the question, from Chapter I, pertaining to the effect BIT will have on personnel quality and staffing. The advanced technology will allow for the repair of the MLRS with fewer mechanics. These mechanics must continue to be the highest quality possible because they must have the ability to operate or be trained to operate the computer system associated with BIT. The application of BIT will require both the crew and direct support mechanic to perform more tasks. This will be covered in more depth in the next

Chapter. Due to the application of BIT, maintenance tasks can be moved forward in the repair process and will lead to the reduction in the required levels of maintenance from four to three.

5. Structure

Even with the reduction in forces, the mission of the Army (with Allies and forces of the sister U.S. services) is to deter aggression or coercion against the U.S., its allies, and National interests abroad. The forces must be capable to fight and win any level of conflict anywhere in the world if deterrence fails. The forces must also provide capabilities for operations other than war and support domestic civil authority. To accomplish these missions, the total Army consists of the following components:

- Active Component
- Reserve Components
- Civilian Component

The Active component force structure has been reduced to ten Divisions from eighteen and the reserves comprise an additional eight Divisions down from ten . The Active Army during FY 1987 had 781,000 soldiers, and during the 1997 fiscal year will field a force of 495,000, a 36.6 percent reduction in ten years. The smaller force must support and execute the current National Military Strategy and fulfill the outlined roles and missions.

Within this structure there are three subdivisions of forces:

- Combat Arms
- Combat Support
- Combat Service Support

The Combat Arms are those units whose mission is to engage the enemy with direct or indirect fire weapons. These units are to gain or hold geographic locations or to prevent the enemy from obtaining these geographic areas. Examples of these units are: Infantry, Armor, and Field Artillery. The combat support units directly assist the combat arms units in accomplishing their mission. Examples of these units are the Combat Engineers, or the Signal Corps. Combat Service Support units perform logistical support and administrative support that enable the combat and combat support units to perform their mission.

Combat Service Support units are task organized at the Corps, Division, and Brigade levels. The organization is comprised of units at all three levels to provide support for personnel and manning requirements, maintenance support, rations, fuel/water, ammunition and equipment replacement, and transportation.

The Corps Support Battalion (CSB) provides support to the units that locate in the Corps area on the battlefield. This is approximately 100-150 km from the Forward Line of Troops (FLOT). The CSB also provides backup support for the Main Support Battalion (MSB). The MSB provides support to the Divisional and non-Divisional units which operate in the Division area. This is approximately 30-70 km from the FLOT. The MSB is usually comprised of five companies that provide support in transportation, ground equipment maintenance, electronic and missile maintenance, supplies, and medical. The MSB also provides backup support for the Forward Support Battalion (FSB). The FSB provides support to the units that operate in the Brigade area on the battlefield. They operate approximately 10-25 km from the FLOT. The FSB is usually comprised of three companies

that provide support in the areas of: supplies, medical and maintenance. These companies have elements operating in the Brigade area approximately 20-25 km from the FLOT.

With the reduction in forces, it has become more critical to repair weapon system as quickly and as far forward on the battlefield as possible. The use of advanced technology systems and modernization of current systems must be implemented to facilitate quick repair to the forward combat units. The use of BIT technology will improve readiness thereby shortening the time that systems are not available by assisting crew and support mechanics in fault isolation. Beyond speeding up the repair process, BIT technology enables the complicated diagnostics and repair much closer to the FLOT than ever before.

E. SUMMARY

This chapter has reviewed the factors leading to the evolution and need for the BIT maintenance concept. The changing National Strategy coupled with decreasing budgets have focused the logistician to aggressively seek ways to become more efficient in order to maintain the required readiness levels. With the development and implementation of advances in technology, readiness levels can be greatly enhanced. The use of BIT will enable the more extensive repair of the fire control system in the MLRS forward on the battlefield by repairmen that were unable to complete repairs prior to this technology.

III. ADVANTAGES AND DISADVANTAGES OF BIT MAINTENANCE CONCEPT

A. INTRODUCTION

In November 1992, the MLRS project office awarded a cost plus award fee (CPAF) contract to Loral Vought Systems Corporation (LVS) for the engineering and manufacturing development (EMD) phase on a modification of the current fire control system (FCS) in the MLRS. The modification of the FCS will include both hardware and software improvements. The primary focus of this chapter is to review the advantages and disadvantages of the use of BIT in the FCS. The specific areas that will be covered in this chapter are the effects on system readiness, crew and maintenance personnel, and related costs of software and hardware improvements.

B. READINESS

The MLRS was developed in the late 1970's, with initial delivery of systems occurring in 1982. Changes in the system have occurred to accommodate munitions, but the basic design and internal composition have not changed. In 1991, the system was reviewed for potential obsolescence. This revealed that nine percent of the microcircuits used in the system were obsolete, 32 percent were in their declining years, and by fiscal year 2003, 92 percent will no longer be available in the market place. The remaining eight percent will not be far behind. This validates the requirement that the system must be modernized. [Ref. 4]

The readiness of the MLRS must have as a Minimum Acceptable Value (MAV) mission availability of 88 percent and a system readiness objective (SRO) of 90 percent availability. The required Best Operational Capability (BOC) of the system is 92 percent, based on the following mission description. This mission description is based on the performance of individual launchers per day.

- Launcher loads fired 14
- Reload operations 14
- Launcher relocations 20
- Total distance traveled 21 km*

* Travel distance is based on 20 percent primary roads, 30 percent secondary roads and improved trails and 50 percent cross country and unimproved trails. [Ref. 3, p.35]

The current FCS has a Mean Time between Hardware Mission Failure (MTBHMF) of 306 hours and a Mean Time Between Operational Mission Failure (MTBOMF) of 279 hours. MTBHMF is the time between failure in the developmental testing (DT) environment and does not include soldier induced failures. MTBOMF is the time between failure during operational missions and includes soldier errors. Under the current maintenance concept the Mean Time to Repair (MTTR) the system is 1.28 hours. [Ref. 23]

The application of advanced technology LRUs and BIT into the FCS of the MLRS, is predicted by the contractor and the project office reliability section to greatly enhance the reliability of the system. The system's MTBHMF is anticipated to be 674 hours and the MTBOMF is predicted to be 341 hours. [Ref. 23] This reflects an improvement of 368 hours (111%) and 62 hours (22.2%) respectively. The increase in the MTBHMF and that of MTBOMF seems to be inconsistent because one would think that the ratios would remain

approximately equal or grow closer together. There does appear to be an available explanation. With the application of BIT, the MTTR is predicted to be reduced from 1.28 hours to .68 hours, a 47 percent improvement at the organizational level and to .8 hours, a 38 percent improvement at the direct support level. The application of BIT greatly reduces the diagnostics time required in the repair process. This application of BIT will greatly reduce system downtime and ensure that the system is quickly repaired and available to perform the mission. [Ref. 23]

Advances in technology, in the areas of design and manufacturing, have enhanced the readiness of the system. Modern electronic components have longer operational life expectancy and better readiness. With the modification of this system, plans were also made to incorporate advances in technology to enhance the maintenance concept through the use of BIT. A corollary advantage of integration and use of BIT in the FCS will be improved system readiness. The FCS will use the BIT to detect, isolate, and tag part failure and/or system failures. The BIT is being designed to isolate defective CCA in the LRUs to a 95 percent detection capability and with a six percent maximum false removal occurrence. [Ref. 4]

BIT failures will be identified and recorded in the nonvolatile memory of the failed CCA. Each BIT failure will alert the operator by displaying a prompt on the FCP and/or sounding an audible alarm. Also, each BIT will be placed in a BIT log, in the main memory and nonvolatile storage for operator/maintainer use.

BIT is categorized into four functional classes and four operational modes. The four BIT classifications are: Automatic, Background, Operator-Oriented, and Event-Oriented. The automatic BIT is a continuous check and reporting of the system's LRUs and CCAs. An example of a typical automatic BIT fault warning occurs when voltage levels fluctuate. The background BIT is performed while the CPU is in "idle" mode. The background BIT checks system status and setting against programmed standard default settings. This function also updates the master storage device (MSD) with the system's status. The operator-oriented BIT classification occurs when the crew request a specific test. This will provide the crew with specific information on any LRU or CCA failures. The final classification is event-oriented BIT. This occurs when the crew initiates an operation such as a fire mission. The system performs a self check prior to allowing the crew-directed event to occur. [Ref. 14]

Table 3-1 outlines the four BIT classifications.

BIT CLASSIFICATION	ACTIVITIES	TYPICAL OCCURRENCE
Automatic	Always sensitive "Instantaneous" response and reporting.	Voltage Level
Background	Performed when CPU is not processing other tasks. (CPU "idle" mode)	CPU instruction set checks. RAM checks.
Operator-Oriented	Operator selects, causes, and receives a particular BIT result.	Operator Requested.
Event-Oriented	Performed before event is allowed to occur.	System Initialization. Pre-Fire Mission checks. Pre-Launcher Lay checks.

Table 3-1 Classes of BIT [Ref. 14]

The four operational modes of BIT are: Power On Self Test (POST), Background, Commanded, and Maintenance. These modes provide the crew with current status on all launcher systems. The POST is a systematic means to conduct an initial electrical inspection of the system. This test sets up the system to the programmed default settings and provides the initial status of the system's LRUs and CCAs. The background BIT mode occurs when POST is completed. This mode compares information previously stored in the MSD with that of the current system enabling it to conduct diagnostic fault isolation procedures. The commanded BIT is operator-oriented and provides the crew with LRU and CCA failures in the current system. The commanded BIT can provide the crew with historical data to assist in system diagnostics. It is used to isolate failures detected during POST and Background BIT. The maintenance BIT is used to diagnose failures not isolated during commanded BIT. This mode requires operator/maintainer intervention and the use of the CTS for more in-depth fault isolation. This mode requires the system to be restarted to exit maintenance manager. [Ref. 14] Table 3-2 outlines the four BIT modes.

The readiness of the launcher is greatly enhanced with the application of recording BIT failures in the nonvolatile memory. This information provides the crew and maintenance personnel with accurate, current information on the status of all launcher LRUs and CCAs. The MSD stores and continually updates the storage of the last 60 seconds of data regarding the system and BIT configurations. The MSD also records the last 100 hours of operational data regarding LRU and CCA failures and replacements. [Ref. 14] This built-in maintenance log can provide vital information to the crew and maintenance personnel in isolating problem areas within the system. The BIT is currently focused on diagnostic analysis of the launcher.

However, the use of MSD and recording system failures may lead to the application of prognostics in fault detection and reduce system down time even more.

BIT OPERATION MODE	ACTIVITIES/TASKS
Power On Self Test (POST)	System Start Up
Background BIT	Includes "Background" and "Automatic" BITs
Commanded BIT	Defined as "Operator-Oriented" BIT Captures 95% of CCA failures Provides Historical Data
Maintenance BIT	Requires Maintenance BIT software to download and overwrite tactical software in FCS. Retrieves CCA BIT stored in nonvolatile RAM. Retrieves all LRU and CCA serial numbers. Retrieves hardware and software configurations that the LRUs were in. Isolates all CCA failures May use "walk up" Contact Test Set (CTS) by maintenance personnel if FCP is inoperative. Uses CTS to isolate CCAs, and LRUs to a 95% detection level with no more than a 6% false removal occurrence.

Table 3-2 BIT Modes [Ref. 14]

One disadvantage of the BIT concept is the increased complexity of the computer system. The dependency on BIT requires the contractor to design the system to a higher specification. This higher design specification will in turn increase the developmental cost. The complexity of the BIT and the thoroughness of the system's self test will also increase the required startup time for the system. [Ref. 14]

Another disadvantage of the BIT at this time is that the software was developed before the hardware. Because of the newness of this concept, the developmental methodology was top driven instead of developed from the user requirements. This design process has not completely explored or captured the full range of capabilities of the BIT. Future generations of BIT may provide a larger range of capabilities such as prognostics and fault isolation into mechanical pumps, lines and connectors. [Ref. 14]

C. PERSONNEL

The application of the BIT concept in the FCS will affect the operator and the maintenance personnel. Both sets of personnel will require additional training in proper use and manipulation of the increased information available to them from the BIT diagnostics.

The MLRS crew will now be able to monitor the current maintenance status of the launcher before, during, and after conducting the fire mission. The crew size will remain at three soldiers, but due to advances in fault isolation they will have more maintenance responsibility than previously. Due to the early stages of the program, the completed additional maintenance task list performed by the crew is not available. However, in the Patriot system, a similar application of BIT has resulted in a planned shift of 75 percent of the DS work to the operator/crew. The majority of these tasks are related to the isolation, removal and replacement of faulty LRUs and the use of the additional information available to the crew regarding fire missions and launcher status. [Ref. 21]

The use of BIT will also add additional maintenance requirements to the DS maintenance personnel. With the improved accuracy and more comprehensive diagnostics of the system, the DS mechanic will now be authorized to replace CCA, a procedure

previously performed by the GS calibrations technician. With the additional training requirement for CCA replacement, the DS mechanic's advanced individual training will be extended by six weeks. This additional training will focus on using the BIT, the removal and replacement of CCAs in the LRUs, the use of the associated contact test sets, and also the use of the electronic technical manual. [Ref. 4]

The application of BIT enables the levels of repair to be reduced from four to three. This occurs due to the gained capability for the DS mechanic to perform the GS mechanic's maintenance tasks. It completely removes the GS mechanic from FCS maintenance which reduces MLRS repair time on the battlefield. It also reduces the distance on the battlefield that the faulty part must be transported to be repaired. Compression of maintenance levels will also reduce the quantity of LRUs required in the repair part supply system. The reduction in LRUs is possible because they will be repaired and returned to the supply system farther forward in reduced maintenance cycle time.

Disadvantages the BIT concept places on the crew and maintenance personnel are the additional maintenance tasks each soldier will be responsible for. This increased responsibility will cause greater difficulty for junior soldiers as they work to become proficient during their Advanced Individual Training (AIT) and to remain proficient at their units. The on-the-job-training program (OJT) in MLRS units will become of greater importance.

The reduction of the quantity of repair parts in the supply system resulting from the implementation of BIT could be viewed as a disadvantage during war operations. Although

this is good during "Peacetime" operations the shortage of repair parts during actual "Combat" conditions might significantly reduce system readiness and adversely affect the capability of the combat units.

The advantages associated with the training of the MLRS crew and maintenance personnel is the ability to use current trainers with software and minor hardware changes and with minimal increase in required training time for each Military Occupational Speciality (MOS) and the corresponding Advanced Individual Training (AIT). The AIT for the MLRS crew will be extended from six to eight weeks to enhance the training on the improved Fire Control Panel (FCP). This training will include tasks related to conducting fire missions and the additional maintenance requirements placed on the crew with the implementation of BIT.

The AIT for the direct support mechanic will initially be extended from 16 weeks to 22 weeks during the transition phase while both the current and the improved FCS maintenance procedures are taught. Once the IFCS is completely fielded the AIT is expected to return to 16 weeks. The training plan for the DS maintenance of the IFCS is restructured to include the additional tasks the DS mechanic must perform, such as circuit card assembly removal and replacement that was previously a GS function.

As mentioned above, the current crew and maintenance trainers can be used with software and minimal hardware changes. This will minimize the disruption in current training while keeping costs low. Currently, there are 18 stations at Ft. Sill Oklahoma used to train MLRS crewman. Initially, five stations will be converted to train crews on the IFCS. There are currently two sets of classroom DS mechanic trainers at Redstone Arsenal, Alabama, each consisting of one instructor panel and six student stations. In addition, there are seven

pedestal mounted loader launcher modules (LLM) used for training. Initially, one additional set of classroom trainers is being purchased and the current trainers will be modified as fielding progresses. Three of the seven pedestal mounted LLM will be modified for the initial training.

The trainer used for both crew and maintenance personnel uses an application of the tactical software. This method minimizes costs and ensures that personnel receive realistic training on equipment that uses the same tactical software they will use in field conditions. The current trainer uses a PC emulator to run the tactical software. The cost for the training software is tracked from the tactical software. Currently, the training software contract cost \$334,000 per year for each trainer. [Ref. 14] The contract ensures the trainers are maintained and software upgrades are provided as required.

A concurrent development to enhance maintenance is the fielding of an electronic technical manual (ETM). It will eliminate the paper technical manuals and provide the mechanic with a tactical laptop computer with CD ROM capability. The system will provide step by step instructions on troubleshooting and repair procedures. The electronic TM will be written at the same reading level as the paper TM and will have visual flash warnings concerning hazardous/dangerous procedures.

Due to the dependency on the ETM by the BIT maintenance concept, several disadvantages of this subsystem must be considered. High durability and survivability of the laptop computer in field conditions are essential to gain the maximum benefit from BIT. The accessibility and useability of the computer while the mechanic is performing maintenance is also a consideration and an area of concern. The power supply for the computer (AC or DC),

the battery life, and the storage location of the ETM in the maintenance vehicle during travel are all critical areas that could degrade or neutralize the capability of BIT. [Ref. 15]

D. COST

The IFCS is a major product improvement to the existing MLRS launcher, and is considered an acquisition category (ACAT) III program. The total procurement authority for the M270A1 (MLRS upgrade), which IFCS is included, is currently estimated at \$1,072 million. [Ref. 26] Because the IFCS is an ACAT III program, there is no regulatory requirement to conduct a Cost and Operational Effectiveness Analysis (COEA). Because of this, the program office did not conduct an in-depth Life Cycle Cost analysis of the modification.

A major advantage of the IFCS is the associated cost savings from the improved LRUs, and the use of BIT to more efficiently isolate faulty parts. The project office has calculated anticipated savings due to the application of the new LRUs and the increased readiness of the system through the use of BIT. The IFCS is projected to reduce Operations and Support (O&S) costs by approximately 30-35 percent over the current fire control system. Savings in O&S will be attributed to the gained efficiency in correctly diagnosing and repairing faults. Other cost savers will be in the areas of inventory reductions, storage, and handling costs. These projected savings are based on a 20 year life cycle and the application of the modification to 857 launcher sets.

According to the IFCS product manager, the IFCS will save approximately \$800,000-\$900,000 per year in O&S costs for the MLRS fleet. The IFCS will also reduce cost through the use of commercial, and non-military specifications in an "Open" architecture. [Ref. 19]

The IFCS implementation shall utilize common hardware, software, and interfaces in all line replaceable units (LRU) designs. LRUs shall allow for technology insertion which mitigates obsolescence and promotes growth. Data buses, buses, processors, and memories shall be implemented using controlled standards and military qualified electronic components. All circuit card assemblies (CCA) used to implement identical or common FCS functions (e.g., MIL-STD-1553 interface, Institute of Electrical and Electronics Engineers (IEEE) 802.3 interface, power conditioner modules, processor CCA, memory CCAs etc.) shall be common and interchangeable between LRUs. [Ref. 20, p. 11]

The software and hardware of the IFCS were designed to embed the BIT throughout the system. Because of this design, the specific cost of the BIT software is not identifiable separately. To reduce developmental costs the Government has furnished the contractor with a RATIONAL R1000 software development environment at a cost to the Government of approximately \$1.2 million. The RATIONAL R1000 generates and manages a software development library as part of the development environment. [Ref. 19]

The IFCS provides the MLRS with improved, modern LRUs. Figure 3-1 depicts how the new LRUs replace the old system and shows the addition of the meteorological sensor. The specific function of the old and new LRUs were outlined in Chapter I of this thesis. Refer to Figure 1-4 for comparisons of the old and new LRUs and improvements contributed by each to the system.

Figure 3-1 depicts how the new LRUs (inside the large boxes) in the IFCS replace the old LRUs (inside the smaller boxes) in the FCS of the current M270 launcher. The new

LRUs do not directly, or in a one for one manner, replace the LRUs of the old system. For example:

Old LRUs

- 1) Electronics Unit (EU)
- 2) Communications Processor (CMP)
- 3) Fire Control Unit (FCU)
- 4) Electronics Box (EB)

New LRUs

- 1) Launcher Interface Unit (LIU)
- 2) Main Processor (MP)
- 3) Communications Processor (CMP)

In this example, the capabilities and functions of the left column are completely replaced by the capabilities and functions of the right column.

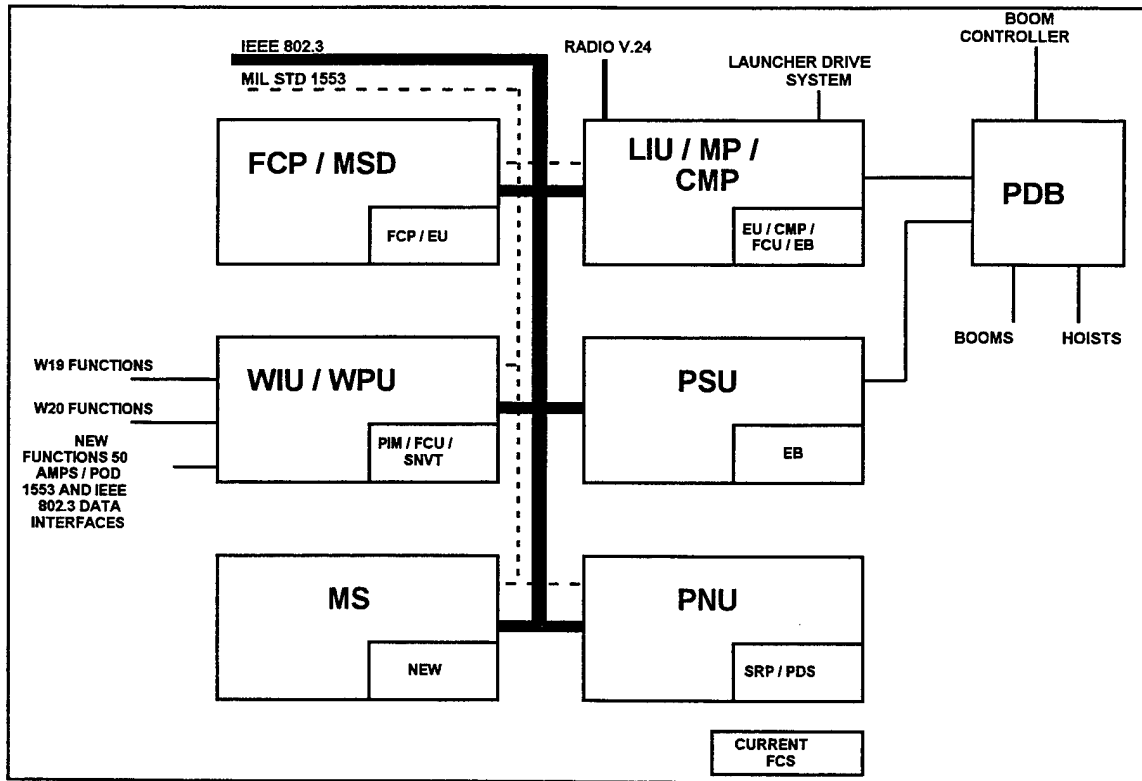

Figure 3-1 IFCS LRU Interconnections [Ref. 2, p. E-11]

The meteorological sensor (MS) is expected to cost \$121,325 based on the procurement of 857 launchers. Due to recent test results and the performance of the MS sensor the program office has decided to proceed with the IFCS modification without including the MS sensor. Improvements in other components of the fire control system have made the MS sensor unnecessary. [Ref. 27]

In constant 1996 dollar terms, the LRUs in the old system will cost \$505,326. [Ref. 25] The corresponding LRUs for the new system are projected to cost \$520,257. [Ref. 24] This is the average unit cost based on the procurement of sets for 857 launchers. The following shows the projected costs of the LRUs in the IFCS. These LRU expenses reflect the cost per launcher and are based on the fielding of 857 launchers. The costing information only includes the cost of the hardware since the BIT software developmental costing information is embedded in the total systems software expenses. Therefore, identification of BIT software costs is unavailable at this time. [Ref. 14]

OLD LRU		*NEW LRUs		
EU	\$125,320	LIU		
CMP	\$ 24,902	WIU		\$374,386
FCU	\$ 82,226	PSU		
EB	\$ 10,144	FCP		
PIM	\$ 60,740			
SNVT	\$ 3,041	PNU	\$145,871	
FCP	\$ 34,793			
SRP				
/PDS	<u>\$164,160</u>			
	\$ 505,326		<u>\$ 520,257</u>	

* These values are projected average unit costs at constant Fiscal Year 1996 dollars. [Ref. 24]

The current MLRS launcher (M203), requires \$3,135 per year in Operations and Support Costs (O&S). The program office projects that the O&S costs of the IFCS (per launcher) without the MS sensor will be \$2,178 per year, approximately a 30 percent saving. The O&S savings is about \$1,000 per launcher per year or about \$800,000-\$900,000 per year for the MLRS fleet. These costs are hardware only and do not include software costs which are not known. However, recall that the growing obsolescence of the old LRUs would lead to extreme retooling costs for remanufacturing and therefore would eliminate the option of using the old LRUs.

With the decision not to include the MS sensor, the LRU costs combined with the reduced O&S costs will make the expense of the upgrade approximately equivalent to the expense of the current FCS. There will, however be costs savings associated with the reduction in man-hours due to the compression in the levels of maintenance for this system. There will also be costs savings in inventory stocks reduction, inventory handling, and transportation. The costs savings for man-hours and inventory reduction are not quantifiable at this time. This modification will solve the obsolescence issue while enhancing the systems readiness with little or no increase in costs over the 20-25 year life expectancy of the system.

E. SUMMARY

The improved fire control system (IFCS) is a significant upgrade to the current FCS's capabilities. The improvements include: enhanced readiness through improved LRUs and BIT, reduction in the levels of maintenance, greater maintenance capability at the crew and DS level due to BIT, and associated life cycle cost savings due to the improved LRUs and the use of BIT.

The advantages and disadvantages of improving the FCS in the MLRS have been covered in this chapter. Although there are disadvantages, the advantages are far outweigh them. The approximate 20 percent increase in MTBOMF of the systems LRUs coupled with the 30-40 percent and 40-50 percent reductions in the MTTR at the organizational and direct support levels, respectively, are tremendous advantages gained with the upgrade. By using the BIT concept, the reduction from four to three levels of maintenance significantly improves the system's ability to be repaired and returned to the fight farther forward on the battlefield. These improvements are anticipated to reduce the annual O&S expenses of each MLRS launcher by approximately \$1000 per year, and a total MLRS fleet savings of approximately \$800,000-900,000 annually.

This chapter provided detailed information about the advantages and disadvantages of the BIT maintenance concept as it related to readiness, personnel and cost. It has shown that there are both advantages and disadvantages associated with BIT. However, the increased efficiencies gained by using BIT outweigh the disadvantages and lead to enhanced readiness, reduction in maintenance levels, and reduction in the number of soldiers in the maintenance process which all lead to cost savings. The next chapter will summarize the information in this thesis, briefly discuss the barriers to fielding the BIT concept and make recommendations for future research.

IV. SUMMARY

A. INTRODUCTION

This thesis has presented information on the reasons for integrating BIT into the FCS of the MLRS. Factors both internal (obsolescence) and external (changing doctrine, National Strategy, force level, and budgetary reductions) have all contributed significantly to the development of the BIT maintenance concept. The following sections will summarize the answers to the original thesis questions, provide reasons for integrating BIT into other systems, discuss possible barriers to fielding, and recommend future research areas.

B. ANSWERS TO RESEARCH QUESTIONS

The application of BIT will provide a means to assist in ensuring that the System Readiness Objective (SRO) of 90 percent for the MLRS and its FCS are maintained. Improvements in readiness will be gained by increasing the efficiency of correctly isolating and repairing failed LRUs. The BIT is being designed to isolate defective CCAs in the LRUs to a 95 percent detection capability and with a six percent maximum false removal occurrence. The BIT will provide a means to move many Direct Support Maintenance tasks to the organizational level and also remove the General Support mechanic entirely from the maintenance support of the FCS in MLRS. This compression of the levels of maintenance will reduce downtime of the system and facilitate repair far forward on the battlefield. The application of BIT and the improved LRUs is estimated by the project office to reduce MTTR by approximately 35 percent at the organizational level and approximately 45 percent at the Direct Support level.

Budgetary factors have been one reason leading to the development of BIT. As covered in Chapter II, the reduction in O&M, procurement, and RDT&E funding has forced the Army to seek technologically advanced means to maintain readiness. The BIT maintenance concept enables the readiness to be achieved by fewer maintenance levels. The increased efficiency of the diagnostics of BIT will also lead to reductions in the needed stocks of repair parts in the Army supply system. These cost savings coupled with the associated reductions in shipping, storage and handling cost of the repair parts will lead to additional cost savings.

Due to the ongoing development of the associated software, exact costing information is not available. The project office estimates that the upgrade in the FCS will save approximately \$800,000-\$900,000 per year on O&S costs for the MLRS fleet. This represents an approximate 30 percent savings in Operational and Support (O&S) costs over the current FCS. These projections are based on a 20 year life cycle and fielding the modification in 857 launchers. [Ref. 27]

The cost of the LRUs in the IFCS as compared to the old system reflects a \$15,000 increase per system. This does not include the cost of the meteorological sensor (\$121,325) in the IFCS. Although there is an increase in cost in the IFCS, the approximate 20 percent improvement in the LRUs MTBOMF will lead to cost savings over the life of the system. Based on the current systems MTBOMF of 279 hours verses the projected MTBOMF of 341 hours for the LRUs in the IFCS, the project office is predicting a reduction in O&S costs of almost \$1000 per launcher per year

The staffing requirements for the MLRS crew will remain three. The crew will have more information available because of BIT, and this will place additional maintenance responsibility on them. The maintenance task list is not finalized at this stage of development but a similar application of BIT into the Patriot is expected to shift almost 75 percent of the DS tasks to the crew level. The Direct Support mechanic staffing will also remain the same at two per three launchers. The DS mechanic will gain additional information and maintenance responsibilities due to BIT. S/he will also now have the capability to replace CCAs in the LRUs at the launcher site.

The Advanced Individual Training (AIT) for the MLRS crew and the maintenance personnel will be affected with the implementation of the BIT into the FCS. The AIT for the crew will be extended from six weeks to eight weeks. The additional time will focus on training related to the increased information available for conducting fire missions and for the additional maintenance tasks the crew is responsible for performing. The AIT for the DS mechanic will be extended from 16 to 22 weeks. The additional time will focus on performing the maintenance tasks that were previously a functions of the GS mechanic and on the use of the Contact Test Set (CTS) and the Electronic Technical Manual (ETM). Once the transition to the IFCS is completed and instruction on the current FCS has been discontinued, the mechanics course will return to the original 16 week configuration.

Equipment changes associated with integration of BIT into MLRS will occur both externally and internally to the launcher. External changes will be the use of an Electronic technical manual (ETM) and the Contact Test Set (CTS). The ETM will provide the mechanic with automated technical information through the use of CD ROM capability. The

CTS is planned to replace the IFTE in the final stages of the IFCS fielding. Internal changes will be seen in the improved LRUs and the addition of a meteorological sensor. The improved LRUs will add approximately 20 percent to the systems current MTBOMF. The system will also have an improved Fire Control Panel (FCP) which will allow for improved informational graphics and enable the crew to receive, transmit and display more information concurrently on their screen.

The current application of BIT is designed as a diagnostic system. The capability may exist through the use of the Master Storage Device (MSD) for the system to provide some prognostic capability. The prognostic capability may be developed as BIT and will be more fully explored by the program office for future upgrade. [Ref. 14]

This section has summarized the answers to the original thesis questions. This information shows how BIT will assist MLRS and other systems in maintaining readiness requirements. The next section will discuss reasons for integrating BIT into other systems and will provide examples of other systems where BIT is being applied and the reasons for the modification. The benefits associated in both examples are the associated gains in readiness through enhanced maintenance, reduction in down time, and life cycle cost saving. The benefits gained by these two examples are the same for any system that is upgraded or modified to use BIT.

C. REASONS FOR INTEGRATING BIT INTO OTHER SYSTEMS

Currently, the Army's Patriot office is exploring the use of BIT. The Patriot's BIT is called the Integrated Diagnostics Support System. This system integrates multiple off-the-shelf technology tools to enhance system maintenance, reduce down time and save money.

The goals of this system are to reallocate at least 75 percent of the direct support maintenance tasks to the crew level. This application of BIT is planned to improve the MTTR of the overall system by at least 25 percent while reducing the systems' operating costs by \$3.5 million or more per year. [Ref. 21, p.2]

The Air Force is also developing an Integrated Maintenance Information System (IMIS). The IMIS will provide a framework for all maintenance integration efforts across weapon systems within the Air Force. This system will use off-the-shelf computers that will display integrated maintenance information in an interactive format. The system will have access to maintenance data bases and interrogate BIT information. It will use the information from the maintenance data base and the BIT input to provide diagnostic and repair advice to the mechanic. The system will also be capable of ordering the required repair parts to facilitate repair of the system. [Ref. 22, p. 2]

This section has discussed how other services or programs are incorporating BIT into current or future systems. Benefits gained are in system availability, use of off-the-shelf tools to enhance maintenance, integration of maintenance data bases and providing interactive media to advise the mechanic about diagnostics and repair procedures. Regardless of these excellent benefits, there are still associated barriers for fielding the BIT maintenance concept.

D. BARRIERS TO FIELDING

Due to the obsolescence of the current system, the upgrade of the FCS in MLRS must occur. However, barriers to the smooth and timely integration of BIT into the system do

exist. The primary barrier is the difficulty of developing software and properly matching it with new, and in some cases, yet to be developed hardware, given the time constraints of the modification. [Ref. 14]

Budgetary reductions, primarily in the areas of RDT&E and procurement, are also factors in fielding BIT. The funding reductions may constrict the development and testing of BIT that could exploit the full range of BIT capability despite the probability that the full capability of BIT may further reduce the O&M expenses while helping to ensure that readiness levels are maintained.

These two barriers are significant concerns of the project office. Both time and money play a key part in the smooth and timely development of BIT. These factors will continue to determine how fully the capabilities of BIT are explored and developed, and to what extent the system's readiness will be impacted due to modifications.

E. FUTURE RESEARCH

In addition to the information and projections presented in this thesis, future research could examine the actual cost savings from the use of BIT and also evaluate the remote diagnostics used with BIT. Once the IFCS is fielded, there should be the available data to analyze the cost benefit of the modification. Other areas of interest relating to cost reductions would be the areas of reductions in repair parts inventory, repair parts handling, and transportation costs.

The use of remote diagnostics in conjunction with BIT could compress the levels of

maintenance even further. With the capability of the system to conduct diagnostic tests, remotely located mechanical experts could send instructions to the MLRS crew to facilitate repair. This may lead to even greater cost saving.

F. CONCLUSION

Even though BIT has many steps left in the developmental stages, integration of the FCS in the MLRS it will occur. The use of this advanced technology concept in maintenance will lead to many benefits associated with the IFCS in the MLRS and further into other systems in the Army. I fully recommend the use of BIT into this and all weapon systems. The gains to readiness and the removal of soldiers from the battlefield are worth the associated costs.

LIST OF REFERENCES

1. Combined Arms and Service Staff School, Combined Arms Operations, Vol 2, March, 1990.
2. Product Management Office, Integrated Logistics Support Plan (ILSP), Multiple Launch Rocket System (MLRS), June 1995.
3. Cyr, James, Software Engineer, MLRS Project Office, personal interview, 3 September, 1996.
4. Pittman, Jimmie, Logistics Management Specialist, MLRS Project Office, personal interview, 3 September, 1996.
5. Army Regulation 750-1, Army Material Maintenance Policies, August, 1994.
6. Ledbetter, Ruth, Logistics Management Specialist, MLRS Project Office, personal interview, 4 September, 1996.
7. The United States Army Strategic Logistics Plan (ASLP), Department of the Army, Office of the Deputy Chief of Staff for Logistics, February 28, 1995.
8. National Military Strategy of the United States, Chairman of the Joint Chiefs of Staff, 1995.
9. Field Manual 100-5, Operations, Executive Summary, Department of the Army, June 1993.
10. The Army Budget: 1995 Presidents' Budget, Assistant Secretary of the Army for Financial Management, April 1994.
11. Annual Report to the President and the Congress, Perry, William J., Secretary of Defense, March 1996.
12. Funding the Force, SFC Mark Kalinoski, Army, News Service, Army Office of the Chief of Public Affairs, April 1995.
13. National Defense Budget Estimate for FY 1995, Office of the Comptroller of the Department of Defense, March 1994.
14. Pietruszka, Raymond, Computer Engineer, MLRS Project Office, personal interview, September 4, 1996.

15. Colebaugh, Jim, Technical Writer, personal interview, September 4, 1996.
16. Field Manual 43-20, General Support Maintenance Operations, November 1989.
17. Field Manual 43-1, Direct Support Maintenance Operations, November, 1989.
18. Field Manual 43-5, Unit Maintenance Operations, November 1989.
19. Gregory, Frank, Product Manager, MLRS Improved Fire Control System (IFCS), MLRS Project Office, personal interview, September 4, 1996.
20. MLRS Project Office, System Specification for the Multiple Launch Rocket System Improved Fire Control System, May 2, 1994.
21. Integrated Diagnostics Systems Demonstration (IDSD), Home Page, August 13, 1996.
22. GDE Systems Inc., Home Page, August 13, 1996.
23. Olivier, Michael, MLRS Project Office Reliability and Quality Assurance, personal interview, September 4, 1996.
24. Wiseman, Terrie, MLRS Project Office, Program Management Industrial Engineer, personal interview, September 4, 1996.
25. Kelley, Jim, MLRS Project Office, Contractor Support, phone interview, September 4, 1996.
26. Kreider, Steve MAJ(P), MLRS Project Office, Product Manager, M270A1, phone interview, November 25, 1996.
27. Pittman, Jimmie, Logistics Management Specialist, MLRS Project Office, phone interview, November 26, 1996.

INITIAL DISTRIBUTION LIST

1. Defense Technical Information Center 2
8725 John J. Kingman Rd., STE 0944
Ft. Belvoir, Virginia 22060-6218
2. Dudley Knox Library 2
Naval Postgraduate School
411 Dyer Rd.
Monterey, California 93943-5101
3. Defense Logistics Studies Information Exchange 1
U.S. Army Logistics Management College
Fort Lee, Virginia 23801-6043
4. Professor Reuben T. Harris, Code SM/Hr 1
Naval Postgraduate School
Monterey, California 93943-5101
5. RADM Donald R. Eaton, USN (Ret), Code SM/Et 1
Naval Postgraduate School
Monterey, California 93943-5101
6. Professor Jane N. Feitler Code SM/ Fj 1
Naval Postgraduate School
Monterey, California 93943-5101
7. COL Michael W. Boudreau Code SM/Be 1
Naval Postgraduate School
Monterey, California 93943-5101
8. Charles D. Lassitter 2
3909 West Avery Street
Pensacola, Florida 32505