

CLIN0002 DI NO. A004

**INVESTIGATION AND DEVELOPMENT
OF
LITHIUM-CARBON MONOFLUORIDE
AA-SIZE CELLS**

CONTRACT N00167-95-C-4014

PHASE I - FINAL REPORT

For Period of Performance
29 September 1995 to 29 March 1996

Prepared for
Dahlgren Division Detachment White Oak
Naval Surface Warfare Center

Prepared by:
K. Dittberner
D. Rohde

DISTRIBUTION STATEMENT A

Approved for public release;
Distribution Unlimited

RAYOVAC CORPORATION
601 Rayovac Drive
Madison, WI 53711-0960

15 APRIL 1997

19970527 163

Executive Summary

The technical goals for Phase I consisted of a best effort baseline cell design using off the shelf materials, processing and assembly techniques. The goals of this Phase were met with additional improvements that can be made to improve the performance of the cell design to meet the longer term program goals. In summary, the following conclusions apply to the cell development efforts of the program:

- Baseline cell design is complete. 100 cells have been built for the current design and were evaluated on a comprehensive test program.
- The design as presently implemented utilizes a spiral wound construction with a case negative design.
- Assessment of Phase I performance is complete.
- Current performance yields typically 2.2 Ahr out of the cell versus a final goal of 1.8 Ahr or greater. Best performance to date is 2.3 Ahr.
- Low temperature (28°F) and higher rate performance has been very good and exceeds expectations.
- Problems were resolved with a shortfall in cell capacity as a result of degradation of cathode integrity during discharge due to loss of adhesion to the cathode substrate.
- A majority of the development effort of Phase I was in the area of improving cathode adhesion and fabricating handleable electrodes. Originally the cathodes had enough integrity to be assembled into cells, but the adhesion was lost after the cells are assembled due to swelling when in contact with the electrolyte and also due to discharge. These problems have been resolved.
- Initial samples of Dr. Yazami produced CF_x were evaluated and found to be unacceptable due to heavy corrosion of internal components. Corrosion is indicative of HF inside the cell. CF_x was washed as per Yazami to eliminate metal fluoride compounds which could be producing HF and was also unsuccessful to date. Other CF_x material received in January 1996 from Yazami also proved to unacceptable once coin cells were made and tested.
- New materials recently made available from Yazami will be evaluated shortly. Sample CF_x materials produced by other sources have also been received and are being evaluated under Rayovac funding.

- Several potential improvements to the cell design have been identified. These improvements focus on areas of cathode design, alternative binder and cathode materials, redesign of the seal for improved safety performance, changes in current collector substrate, non-magnetic construction, and evaluation of alternative electrolyte systems. This work is in progress.
- Initial Safety evaluations determined that the vents were not releasing properly and a modification was made that now produces acceptable vents and seals. Despite the substandard vents, cells behaved in a controlled manner during short circuit tests. Additional testing is planned with the revised vents.

Foreword

This final report has been prepared as required by contract requirements, sponsored by the Naval Surface Warfare Center with Rayovac Corporation. The work described within was performed under contract number N00167-95-C-4014.

The information presented within this report covers the work completed during Phase 1 of the contract. The period of performance for Phase 1 began on 29 September 1995 and ended 29 March 1996.

The purpose of the work described herein is the best effort development of a baseline AA size cell in the lithium carbon monofluoride chemistry.

An award for stage one of Phase II for the contract was provided and will continue immediately following completion of Phase I with the goals outlined in the original proposal.

Abstract

Phase I of NSWC Contract #N00167-95-C-4014 is complete. A Lithium/CF_x AA cell was developed using a spiral wound case negative construction. Cathode fabrications was via a CF_x slurry coated onto an aluminum substrate and densified. A quantity of 100 cells was produced for testing and evaluation. Theoretical capacities were 2.46 Ahr with 2.2 Ahr regularly attainable and a 2.3 Ahr providing the best performance to date on a 3 mA drain. Performance at low temperatures (28°F) also was well above expectations typical performance at 1.37 Ahr. Additional work was accomplished to characterize alternative materials including Yazami sourced CF_x and aluminum substrates. Preliminary safety testing showed favorable performance despite nonfunctional vents. Corrected vents are now available.

Contents

| | <u>Page</u> |
|--|-------------|
| Introduction | 1 |
| Objectives | 1 |
| Program Structure..... | 1 |
| Description of Work..... | 1 |
| Deliverables..... | 2 |
| Progress vs. Milestones | 3 |
| Current Cell Design..... | 4 |
| Potential Improvements to Current Design..... | 7 |
| Performance of Baseline Design..... | 8 |
| 3 mA Drain Capacity (Room Temperature)..... | 8 |
| 3 mA Drain Capacity (28°F after 130°F Storage) | 9 |
| 50 mA Drain Capacity (28°F)..... | 9 |
| 350 mA Drain Capacity (Room Temperature)..... | 12 |
| 40 mA 5 Second End of Life Pulse | 12 |
| Additional Comments on Performance Testing..... | 12 |
| Electrode Fabrication & Basic Material Studies..... | 12 |
| Cathode Fabrication..... | 13 |
| Physical Optimization | 15 |
| Materials Work..... | 17 |
| Anode Selection/Fabrication | 20 |
| Preliminary Safety Evaluation | 20 |
| Conclusions | 22 |

Illustrations

| | |
|---|----|
| Figure 1: NSWC Li-CF _x Cost Plan/ Actual..... | 6 |
| Figure 2: Cell Construction..... | 11 |
| Figure 3: Typical AA Li/CF _x Discharge Curves..... | 14 |
| Figure 4: Voltage vs. Capacity for CF _x AA Cells | 19 |
| Figure 5: Fluoride Concentrations By Ion Chromatography During Water Washing | 19 |

Tables

| | |
|---------------------------------|----|
| Table 1: Bill of Materials..... | 5 |
| Table 2: Cell Performance..... | 10 |

Introduction

Objectives

As per the original solicitation for this proposal, the Navy is interested in developing and testing prototype AA size cells using the lithium carbon monofluoride chemistry. The ultimate goal is to develop AA size cells capable of forming safe and stable battery packages for several classes of underwater mines. This requires emphasis on low cost, high energy density batteries with good low temperature rate capability.

Program Structure

The program structured is Phase I with option years to follow. The first phase took place over a period of six months. The primary objective during this phase was to develop a best effort baseline AA Lithium (Li)/CF_x cell using the best available off-the-shelf technology and cathode materials with established construction techniques. The design of the cell therefore borrows, initially, from the methods, materials, and techniques developed from previous work of rechargeable lithium ion battery contracts.

Description of Work

The Navy's original solicitation for proposal included investigating the following:

- Development, assembly and evaluation of a minimum of 100 each baseline proof of principle AA size Li/CF_x cells, using the best existing and commercially available materials and fabrication techniques.
- Study, evaluation and incorporation of new materials and improvements into 100 each proof of principle AA size Li/CF_x cells with significant emphasis on novel cathode materials and methods of preparation, electrolytes, separators and other related innovations.
- Emphasis on high energy density designs with good low temperature high rate performance (initially spiral wound construction).
- Methods for increased open circuit and closed circuit voltages.
- Elimination of voltage delay at the start of discharge.

- Final design produced in later option years is to be of a non-magnetic construction.
- Capability of withstanding a wide variety of specified shock and vibration tests with no detrimental effects on battery performance.
- Safety under all conditions of use and abuse.
- Provide good shelf life characteristics.
- Elimination of the voltage dip at the beginning of discharge.
- Cost effective in design and manufacture.

Some additional areas of interest include:

- Effect of cathode processing, cathode thickness and cathode substrate on cell storability and rate capability.
- Effect of solvent and electrolyte selection on cell performance.
- Effect of adding other cathode active materials such as MnO_2 to CF_x to form a composite cathode on cell performance.

Deliverables

Deliverables for the contract were as follows:

- | | |
|--|---------------------------|
| • Monthly Contract Fund Status Reports | Monthly starting 11/3/95 |
| • Scientific and Technical Reports | Quarterly starting 1/4/96 |
| • Draft Final Report | 4/5/96 |
| • Final Report | After comments |

Progress vs. Milestones

As previously stated, the primary objective of Phase I work was to produce 100 best effort AA cells using commercially available components and conventional processing techniques. Design features and fabrication processes were extensively borrowed from Rayovac's rechargeable lithium ion AA government contract experience. Materials selection was also dependent on materials presently used either in Rayovac's commercially produced lithium coin cells or in the rechargeable lithium ion AA cell.

The specific task descriptions outlined in the original proposal are as follows:

1. Cathode Material Selection
2. Cathode Additives
3. Electrolyte Solution
4. Barrier/Separator Material
5. Cell Hardware Selection
6. Seal Material
7. Cell Build
8. Cell Test and Evaluation
9. Documentation and Data

Most of the materials selection tasks proved to be relatively simple due to the reliance on our existing technology base. This applies in particular to selection of the baseline cathode active material and conductive diluent, electrolyte solution, barrier material, cell hardware and seal materials and design. These materials all proved to have acceptable performance for a baseline cell as implemented and would serve as a solid foundation for additional improvement work.

The majority of the effort for Phase I was made in the area of cathode fabrication techniques and formulation. Although some of the processing techniques and materials developed in previous lithium ion work were applicable, significant modifications were required to achieve handleable cathodes in both processing and binder materials.

Presentation of the cell development work is as follows:

1. Current Cell Design Overview
2. Potential Improvements to Current Design
3. Performance of Baseline Design
4. Cathode Fabrication Work & Material Studies
5. Preliminary Safety Evaluation Work

Current Cell Design

The basic cell design developed during Phase I is based on the design used in the rechargeable lithium ion cells which are also being developed under government contracts by Rayovac. The bill of materials for the design is provided in Table 1 on page 5 and refers to the construction diagram of Figure 1 following on page 6.

Features of the current paper design are as follows:

- Case negative design was implemented so that a standard nickel plated cold rolled steel can could be used initially. This can is the same as what is used in the commercial alkaline AA cells. This design approach will not initially meet the non-magnetic requirements that will eventually be necessary and will be implemented in Phase II.
- Current seal design uses a polypropylene header with a 304 stainless steel feed through and ball seal. This is identical to what has been used in the lithium ion rechargeable work. Crimp sealed cells provide good performance for most applications at significantly lower cost than hermetically sealed cells.
- Cathode tab and substrate are aluminum foil. The cathode tab is annealed and the substrate is tempered.
- Anode requires no substrate but does use a nickel tab cold welded to the lithium foil.
- A thin electrode design is currently being utilized because of the limitations of the coating process being used.
- Electrolyte is 50%DME:50%PC:1MLiBF₄ based upon its availability and our experience with it.
- Sealant is standard bitumen dissolved in toluene and painted on the seal and the inside of the can.
- Anode surface area is 235 cm² and cathode surface areas are 245 cm² for the most recently implemented design.

Table 1
Bill of Materials

| <u>Label</u> | <u>Component</u> | <u>Material</u> | <u>Dimensions</u> | <u>Notes</u> |
|--------------|-------------------------|---|------------------------------------|---|
| A | Can | Nickel Plated Cold Rolled Steel | 13.59 mm I.D. | Case Negative Standard Alkaline Can |
| B | Header | Polypropylene | N/A | Molded In-house |
| C | Feed Through | 304 SS | N/A | |
| D | Ball | 304 SS | | |
| E | Sealant | Bitumen with Toluene | As required | painted onto can and header |
| F | Top Separator | nonwoven polypropylene | 12.7 mm Dia | Slit for cathode tab |
| G | Cathode Tab | Aluminum | .13 mm x 2.5 mm x 4.1 cm | |
| H | Cathode consists of: | .025 mm Aluminum substrate coated both sides with mix: 85.5% CF _x 9.5% Acetylene Black 5.0% PVDF | .23 mm x 3.8 cm x 32.1 cm | |
| I | Anode Tab | Nickel | .10 mm x 2.5 mm x 3.6 cm | |
| J | Anode | Lithium metal | .10 mm x 3.6 cm x 33.0 cm | |
| K | Separator | Celgard 2400 | .25 mm x 4.3 cm x 36 cm 2 plies | |
| L | Bottom Separator | nonwoven polypropylene | 13.9 mm Dia | |
| M | Electrolyte | 50%PC:50%DME:1M LiBF ₄ | | 2.9 gm |

Figure 1

Cell Construction

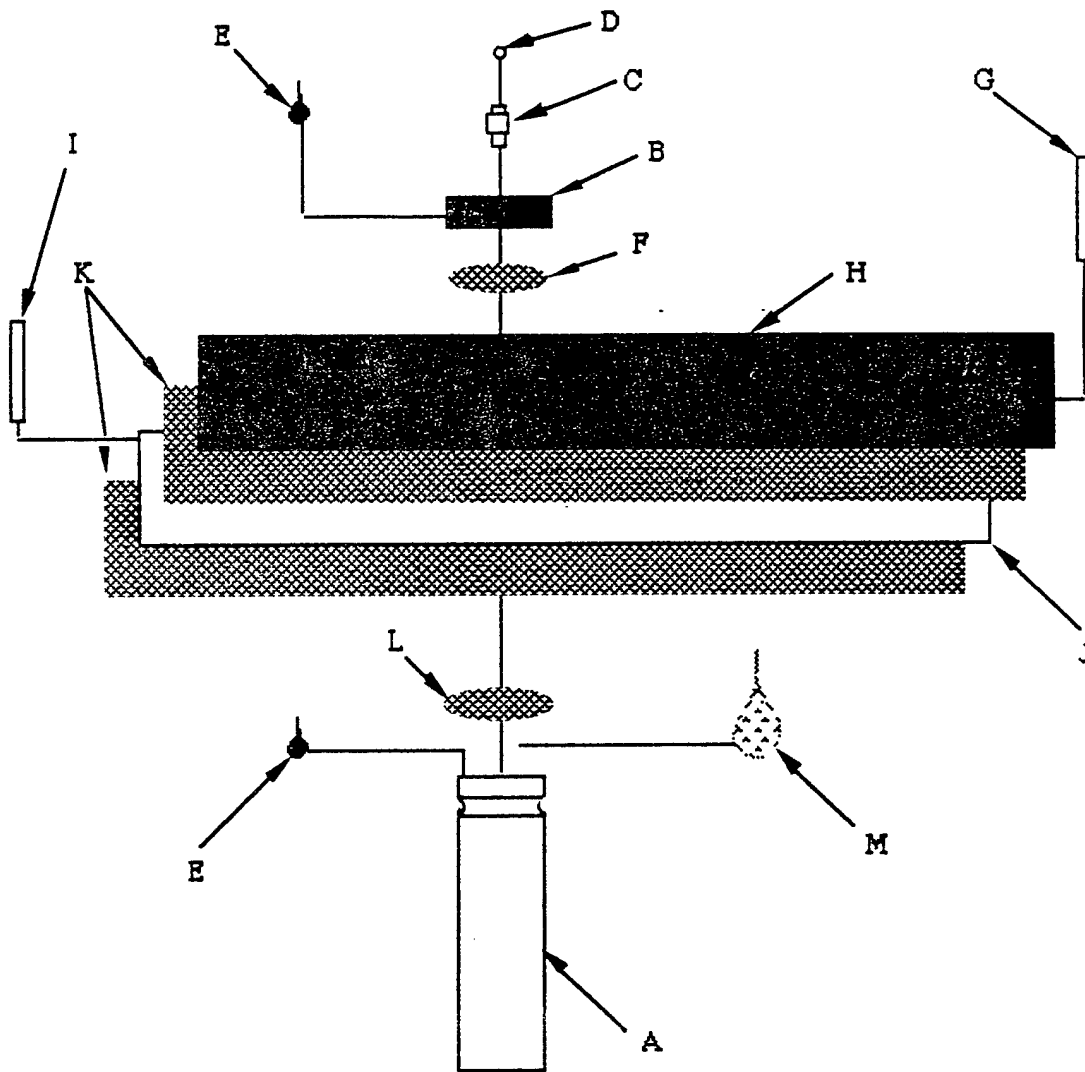

Potential Improvements to Current Design

Several design improvements are anticipated in the future over the present design. These improvements will examine several different areas of performance. Some of the design areas that are currently being investigated are:

- Evaluation of thicker cathodes and bobbin designs.

This could allow for significant increases in cell capacity and energy density which, is a critical factor for the cells from this contract.

- Replacement of a foil substrate with expanded metal for spirally wound designs.

This will allow for increased capacity and potentially provide improved cathode integrity during discharge which has been a limiting factor in cells built to date. For this reason, this is considered one of the highest priorities.

- Alternative binders and/or binder concentrations to PVDF or SBR.

Optimum design provides for good adhesion with the lowest possible binder content. Some binders impact high rate performance by insulating the active material. Binder experiments will be conducted to further improve adhesion to the expanded metal substrates previously mentioned.

- Design changes for non-magnetic cells.

The magnetic requirement cannot be accomplished using a cold rolled steel can. Future design changes using a stainless steel can will be required. Special attention will need to be placed on corrosion effects.

- Replacement of the ball seal with a polypropylene crimp seal.

Although the ball seal has been shown to work reasonably well, high temperature and thermocycle leakage performance is poor. An improved seal design will utilize a metal vent panel in addition to a polypropylene seal. This change will allow for improved control over safety venting over a wide temperature range and improve high temperature storage characteristics. This enhancement will follow on improvements being made with lithium ion rechargeable cells. The crimp seal offers significant cost savings over hermetic sealing options while maintaining good performance.

- Investigation of alternative electrolyte formulations.

This is particularly important for achieving the low temperature high rate performance requirements. Electrolyte salt and solvent systems will be investigated.

- Evaluation of type and concentration of conductive diluents on performance.

The type and amount of carbon used is important for optimum rate performance as well as energy density.

Performance of Baseline Design

The endeavor made during Phase I was performed on a "best effort" basis and was intended to provide a baseline cell for future development work. However, there were target performance goals for the design to be developed for a number of tests. Cells were tested versus these goals, with performance far exceeding expectations in some cases.

An estimate of the cell performance was initially developed based upon data from coin cells. In particular, the BR2016 coin cell size was used as a basis for determining the performance by direct projection of cathode surface areas and densities. This was thought to be a conservative estimate since the thinner electrodes incorporated into the AA cell should result in better discharge efficiencies and theoretically higher cathode densities. In practice, the densities initially achieved with the cathodes were less than desired. In fact, the final cell build was modified into two separate variations after it was discovered that the latest processing techniques for the cathode resulted in improved densities. The first half of the build provided cells of a design intent of about 1.8 Ahr and the second half of 2.3 Ahr. This was achieved by improving the cathode coating and densification processes.

A comparison of the anticipated performance versus actual achieved performance on a variety of tests is presented in Table 2 on page 1010. The most important objective for the Navy, specific to this contract, at the present time is the capacity goal on a 3 mA drain. A discussion of the test results follows.

3 mA Drain Capacity (Room Temperature).

The 3 mA drain rate discharge has yielded cells that typically provide 2.2 Ahr, with the best performance to date of 2.3 Ahr. This is based on a theoretical capacity of 2.46 Ahr put into the cells which corresponds to a discharge of 89% of theoretical. Typical discharge efficiencies for the BR2016 coin cell are 95% of theoretical. These results are excellent considering the additional limitations that

the spiral wound construction places on theoretical discharge efficiency. Figure 2 on page 11 shows the typical discharge data to date for the cells on test.

These results are a significant improvement over the earlier cell builds as well. Cell tear-downs and exams from earlier cell builds showed that a primary reason for the lower achieved capacities at that time were due to poor cathode adhesion to the substrate during discharge. Cathodes have since been developed with good handleability during assembly and improved adhesion is maintained throughout discharge of the cell during which significant cathode swelling must occur. Additional efforts will continue to be placed on cathode processing and materials to obtain further improvements.

3 mA Drain Capacity (28°F after 130°F Storage).

The 3 mA drain rate discharge performed at 28°F, after 45 days of storage at 130°F, yielded cells that typically provide 1.6 Ahr, with the best performance to date of 1.9 Ahr. The variation of cell performances on this particular test are attributed to an insufficient seal (redesign of this seal has been proposed as stated on page 7). The poor seal allows electrolyte leakage, which in turn causes an increased internal resistance, therefore reducing the working capacity. Figure 2 on page 11 shows the typical discharge data for cells subjected to this test.

50 mA Drain Capacity at 28°F

The capacity goal on this test is 0.2 Ahr. This goal was easily achieved with no problems on any of the cells tested. One characteristic observed during this test was that the cell operating voltage is highly sensitive to even small changes in temperature when temperatures are low. It was not unusual to observe voltage changes of several millivolts over only a one or two degree temperature change. A typical discharge curve is shown on Figure 2 on page 11.

Table 2
Cell Performance

| Test | Original AA-Cell | Final Build AA-Cell |
|---|-------------------------|----------------------------|
| Cathode Surface Area | 195 cm ² | 245 cm ² |
| Anode Surface Area | 195 cm ² | 235 cm ² |
| Cell Weight | 11.6 gms | 12.5 gms |
| Cell Volume | 7.15 cm ³ | 7.15 cm ³ |
| OCV | 3.40 v | 3.40 v |
| Operating Voltage (3 mA) | 2.65 v | 2.65 v |
| Short Circuit Current | 10.5 Amps | 14.5 Amps |
| Theoretical Capacity | 2.04 Ahr | 2.46 Ahr |
| Theoretical Gravimetric Energy Density | 466 Wh/kg | 522 Wh/kg |
| Theoretical Volumetric Energy Density | 756 Wh/L | 912 Wh/L |
| Typical Light Drain Capacity (3 mA) | 1.75 Ahr | 2.19 |
| Actual Gravimetric Energy Density (3 mA) | 400 Wh/kg | 464 Wh/kg |
| Actual Volumetric Energy Density (3 mA) | 649 Wh/L | 812 Wh/L |
| Typical Low Temperature Capacity (50 mA @ 28°F) | 1.21 Ahr | 1.37 Ahr |
| Gravimetric Energy Density (50 mA @ 28°F) | 245 Wh/kg | 258 Wh/kg |
| Volumetric Energy Density (50 mA @ 28°F) | 398 Wh/L | 450 Wh/L |
| Typical Heavy Drain Capacity (300 mA) | 1.44 Ahr | 1.61 Ahr |
| Heavy Drain Gravimetric Energy Density | 310 Wh/kg | 322 Wh/kg |
| Heavy Drain Volumetric Energy Density | 533 Wh/L | 563 Wh/L |

Figure 2
Typical AA Li/CFx Discharge Curves

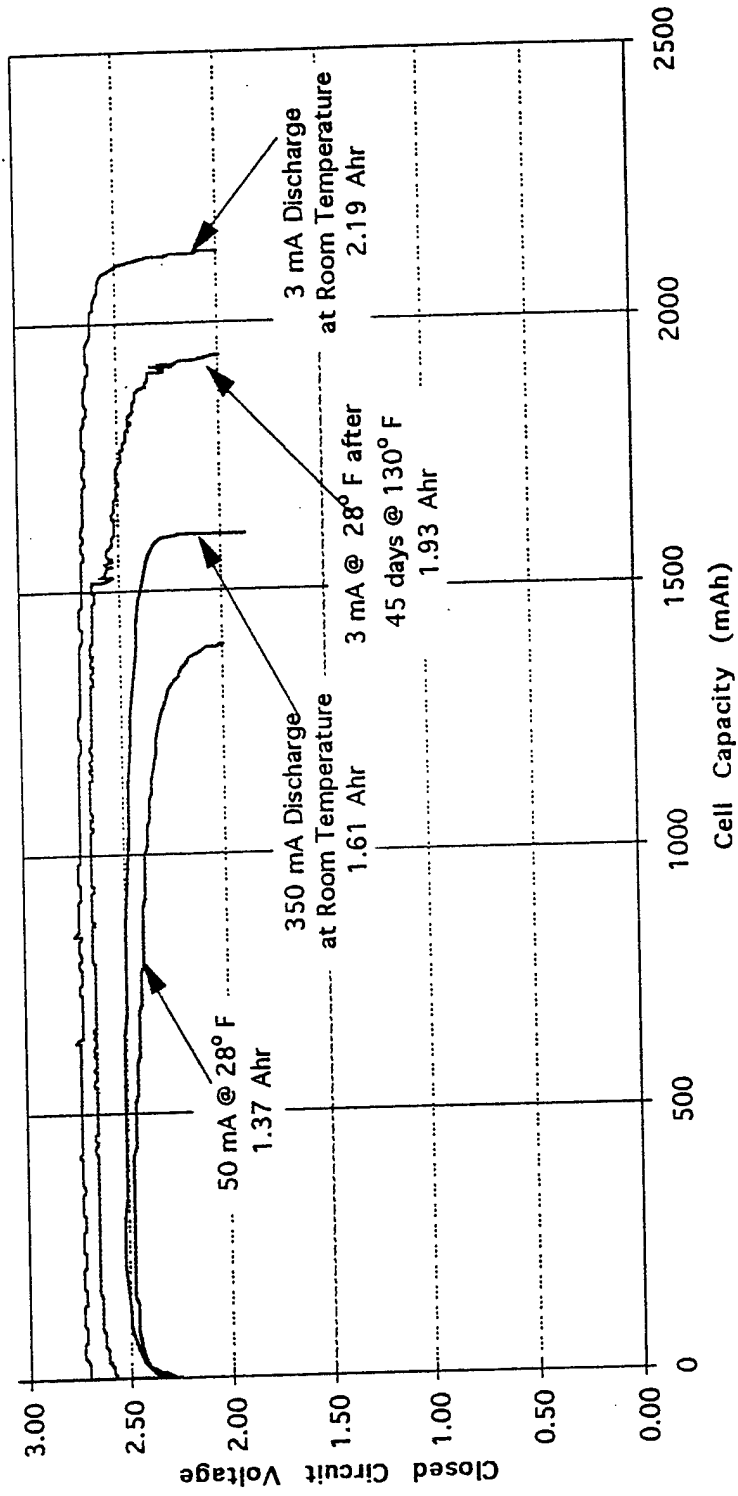

350 mA drain Capacity (Room Temperature)

Although not specifically requested as a requirement, some high drain testing was performed to further characterize performance. Performance on high drain was significantly better than anticipated from projections of the BR2016 coin cell. This can be accounted for by the improved efficiency gained from a thinner electrode used in the AA cell versus that for the BR2016 coin cell.

40 mA End of Discharge Pulse

The specifications for the cell also included a 40 mA end of discharge pulse. The purpose of this pulse is to blow a fuse in the application and no minimum voltage requirement was specified. Therefore, it is assumed that if the cell is capable of providing the pulse at any voltage above zero volts, it meets the requirement based upon the information available at this time. Measurements were made at this condition. This data indicates no problems in meeting this requirement as presently defined.

Additional Comments on Performance Testing

In general, there is significant variability in cell performance on some tests. In particular, the 28°F, 50 mA discharge test had significant variability in capacities which ranged from 900 mAh to 1.63 Ahr. The capacity variability on other discharge tests typically manifests itself as infant mortality. These cells are excluded from the populations when encountered since they do not represent typical performance. Cell exams have identified low resistance internal shorts as the typical problem in these cases due to assembly problems. Some variability is also attributed to the natural variability produced during manual cell and cathode fabrication processes and is expected to improve as processes are further refined and standardized.

Electrode Fabrication & Basic Material Studies

Several studies pertaining to this contract have been initiated to date. These studies have examined both materials and processing issues. These studies are as follows:

- Study #1: CF_x Corrosion of Aluminum Substrate
- Study #2: Washed Low Temperature CF_x Sample
- Study #3 & 4: Optimization of Mix Formulations
- Study #5: Evaluation of revised sample of Cf_x
- Study #6: CF_x Corrosion of Stainless Steel Substrate

Studies #1, 2, 5, and 6 pertain to materials issues independent of cathode fabrication and will be discussed later. Studies #3 and #4 pertain to the mix processing and cathode fabrication issues and will be addressed first.

Cathode Fabrication

Initial efforts have utilized the basic process developed under rechargeable lithium ion contracts. Coated electrodes have been utilized in AA, D and fat D-cells with the lithium ion chemistries, and the performance of these electrodes has been excellent in these cells.

The single greatest problem encountered in the cathode fabrication is poor adhesion of the cathode material to the aluminum substrate. Poor adhesion affects cell performance in the following ways:

1. It limits the ability to adequately densify the cathodes to achieve the desired capacity and cell balance.
2. Makes the cathodes difficult to wind and assemble without problems with separation of cathode material from the substrate.
3. Provides poor integrity on discharge during which the cathode must be allowed to swell while maintaining good contact through adhesion.

Significant progress has been made in cathode processing relative to the adhesion problem. Initial attempts to fabricate cathodes resulted in electrodes that could barely survive the handling required to build cells. In addition, early cell builds had substandard capacities due to the following reasons:

1. Delamination and flaking off of the cathode material resulting in localized internal shorts and loss of internal contact.
2. Low densities resulting in low capacity cathodes.
3. Low cathode densities also provided insufficient stack pressure on low drain discharge to main internal contact.

Subsequent cell builds and cathode processing experiments have resulted in cathodes that survive handling well with accordant improvements in discharge performance. Figure 3 on page 14 shows the improvement in cell capacities in subsequent cell builds to date.

Figure 3

Voltage vs. Capacity for CFx AA-Cells
Low Rate Discharge (3 mA)

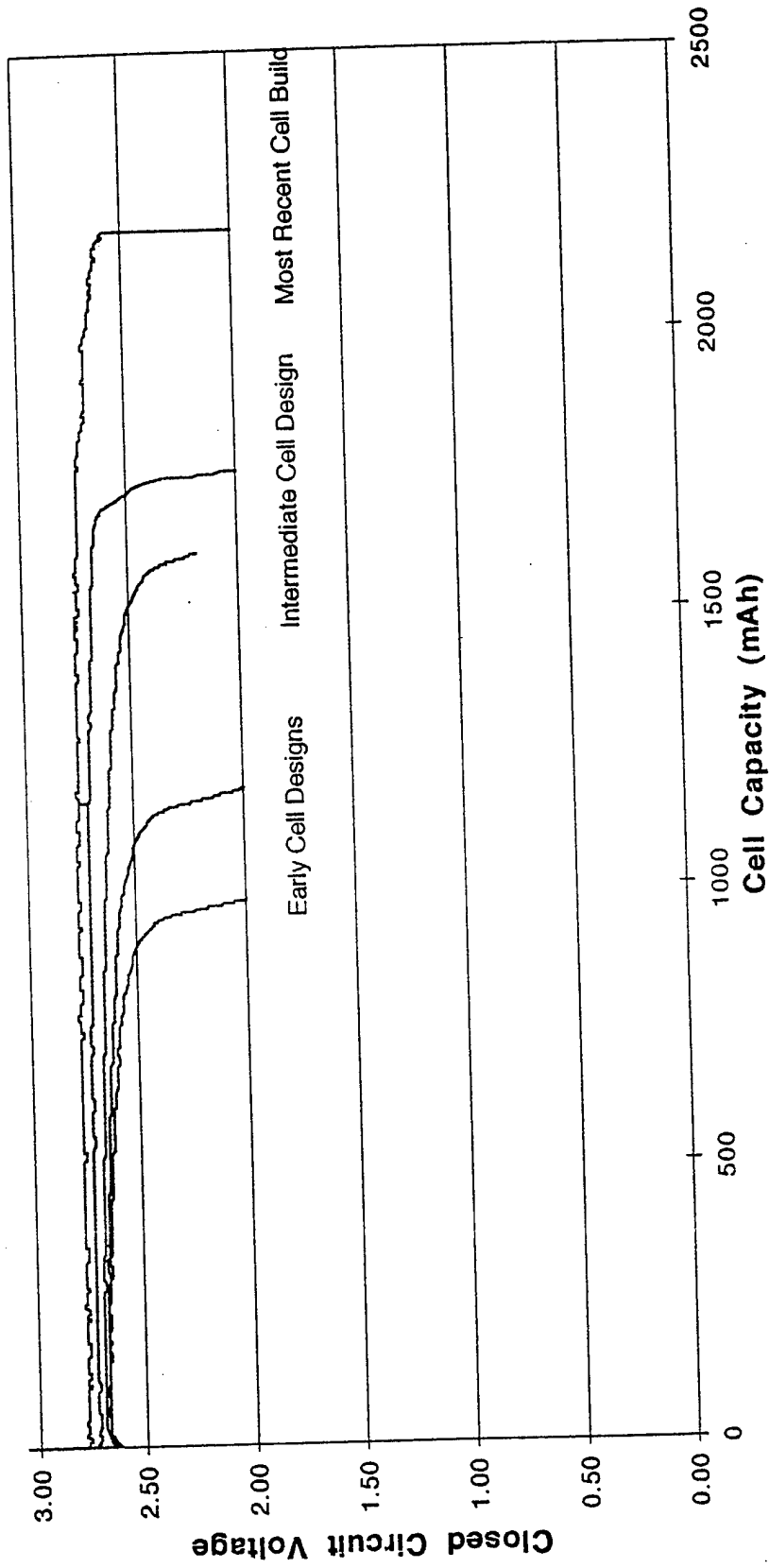

The use of carbon monofluoride, CF_x , in the coating process has required significant adjustments to fabricate special electrodes. Carbon monofluoride is a hydrophobic material that is also used as a lubricant. As a result, it is difficult to wet and bind to a substrate. Most of the cathode work has been focused on modifying the process and the materials to achieve this.

A series of experimental design based runs were made to identify processes that improve adhesion. The variables examined are as follows:

1. Binder type
 - A. Polyvinylidene fluoride (PVDF)
 - B. Teflon (various Teflon suspensions)
2. Binder concentration (from 1 to 7%)
3. Doctor blade thickness settings (ranging from 0.10" to 0.35")
4. Liquid content (DMSO) (30 gm to 90 gm for a 50 gm batch)
5. Densification level
6. Mixing method
 - A. Low shear
 - B. High shear
7. Mixing time.

Our present cathode formulation consists of a cathode premix that consists of 90% CF_x , 10% acetylene black and 5% PVDF. These materials are dispersed in DMSO solvent and coated onto foil substrates using a doctor blade technique. As previously stated, aluminum foil has initially been selected as the current collector because of its following advantages:

- Low weight
- Excellent electronic conductivity
- Electrochemical stability at high oxidizing potentials

Manufacture of the cathode involves applying a coat of cathode slurry to each side of the foil. Electrodes are then dried and densified. Densification was carried out on a roll mill, followed by cutting of the electrode to the correct length.

Physical Optimization

The physical properties of porous electrodes are also extremely important and will determine, to a large extent, the performance capabilities of the cell. For example, electrode conductivity, effective surface area, and porosity affect operating efficiencies, rate capabilities, and low temperature operation are dependent on the physical characteristics. Mechanical ruggedness is also important for assembly and to achieve good performance and high cell reliability.

Thicker electrodes favor specific energy because they reduce the amount of inert materials, such as current collectors and separators. Furthermore, thick electrodes decrease the electrode surface area, reducing short circuit currents, and improving cell safety. Thinner electrodes, on the other hand, favor rate capability because they allow more surface area to be packaged into a given cell volume. Arriving at an optimum cell design represents defining the best tradeoff between specific energy and rate capability.

Once the preferred electrode composition has been selected, work focused on optimizing CF_x electrodes for performance. Our objective in this work was to maximize electrode energy density and operating efficiency through optimization of composition, thickness, and key processing steps. Experimental variables were:

- Binder concentration
- Conductive diluent type and concentration
- Surface area and particle size distribution of the active electrode material
- Current collector material and configuration

A key part of our strategy is to control the surface area of the active material. High surface areas improve rate capabilities and active material utilization but often make electrode processing more difficult. As part of the optimization studies, we still need to determine the impact of surface area, particle size, and particle size distribution on the electrode performance and optimize these properties considering both processibility and electrochemical performance. This work will be performed in Phase II as part of the materials studies.

Another element of our optimization strategy is to achieve and maintain high electrode densities. Higher electrode densities allow more capacity to be packaged within a cell's volume thereby increasing energy density. In addition, the higher electrode densities provide for better electrode expansion during discharge. This expansion is necessary to maintain sufficient pressure on the electrodes to maintain contact within the cell during discharge.

Electrodes were also optimized with respect to composition considering mechanical integrity, rate capabilities, and low temperature performance. Our goal was to optimize the content of binder and conductive diluent in the electrode without sacrificing rate capacity. Since these materials are inactive, they reduce capacity and energy density. It was found that binder concentrations above 5% provided very little additional improvement in adhesion as a result.

An experimental design approach was also applied to optimize the cathode construction. Experimental design work emphasized binder concentration, mix coating processing, and cathode densification. This work is largely responsible for the capacity improvements realized to date. Additional improvements can be expected with supplementary work.

The significant variables determined to improve cathode performance to date in order of effect are:

| | |
|------------------------|--|
| Binder type | PVDF binder |
| Binder concentration | 4% minimum, 5% preferred |
| Mixing time | 5 minutes minimum, 9 minutes preferred |
| Mixing type | High shear |
| Liquid content | High liquid preferred |
| Densification | Dependent variable on adhesion. Densify to desired level and deposition |
| Doctor blade thickness | Not significant, base on target values for deposition |

Materials Work

Although minimal effort was placed into materials studies during Phase I, the availability of some sample quantities of materials allowed for some preliminary evaluation work to be performed.

The materials work concentrated primarily on the following aspects:

1. A new CF_x starting material is being developed in cooperation with the University of Grenoble, France, under the direction of Dr. Rachid Yazami. This work evaluated materials produced using a novel low temperature process that promised CF_x with a higher operating voltage and increased rate capability, though not obtained.
2. Cathode additives to improve rate capability, capacity, and/or voltage level, especially for low temperature operation.

Study #2 addressed whether washing of an initial sample of experimental CF_x obtained from the consultant, Dr. Yazami, improves the material. This was

performed on a sample obtained some time ago which previously had significant problems with undesirable side reactions within the cell. In particular, an initial BR1225 cell build using $CF_{0.8}I_{0.02}$ (LT- CF_x 1) supplied by Dr. Yazami showed catastrophic cell expansion and corrosion of metal parts upon short term storage at high temperature. It was hypothesized that free fluoride was a contributing factor. Work was initiated to identify an appropriate washing method by monitoring the release of F- from the material.

Deionized water was used to wash LT- CF_x 1, per Dr. Yazami. Ion chromatography was used to monitor the F- concentration in the supernatant. Peak integration and peak height measurements by the digital recorder/integrator gave inconsistent results for F- peaks in the supernatant. This was not observed for the standard F- solutions. This problem with the peak integration has not been resolved. As an alternative, peak heights were measured with an analog x-t recorder and used to estimate F- concentration in the supernatant.

In one experiment, 1 g LT- CF_x 1 was suspended in 100 ml of deionized water and stirred. Samples were removed at various times and F- concentration estimated. In this preliminary experiment, the volume changes of the supernatant were not accounted for. It was found that the concentration of F- rapidly increases initially, then continues to increase over 40 hours of washing, but at a decreasing rate. The results of this experiment are shown in

Figure 4 on page 18.

BR1225 size coin cells were made from the washed LT- CF_x 1 and put on test. The cells failed at high temperature storage within one day with most of the test cells having open circuit voltages (OCV) less than 2.0 volts.

Using this information, another washing test was initiated: 50 g LT CF_x #1 was suspended in 1.6 liter deionized water and stirred. The solid was filtered after 5 days and a sample of the supernatant was removed and analyzed for F-. The solid was washed with H_2O and was suspended in 1.6 liter deionized water and stirred 1 day. The solid was filtered and washed with deionized water. The supernatant was analyzed for F-. After the first washing, the F- concentration was dramatically reduced. The results of this work are presented in

Figure 4 on page 18. The material after the second washing was retained for a future cell build.

BR1225 size coin cells were made from the washed LT CF_x 1 and put on test. The cells failed at high temperature storage within one day with most of the test cells having open circuit voltages (OCV) less than 2.0 volts. Results from subsequent cell teardowns and analysis indicate major internal corrosion and consumption of the anode indicating no improvement over the unwashed material.

Figure 4

Fluoride Concentrations By Ion Chromatography During Water Washing

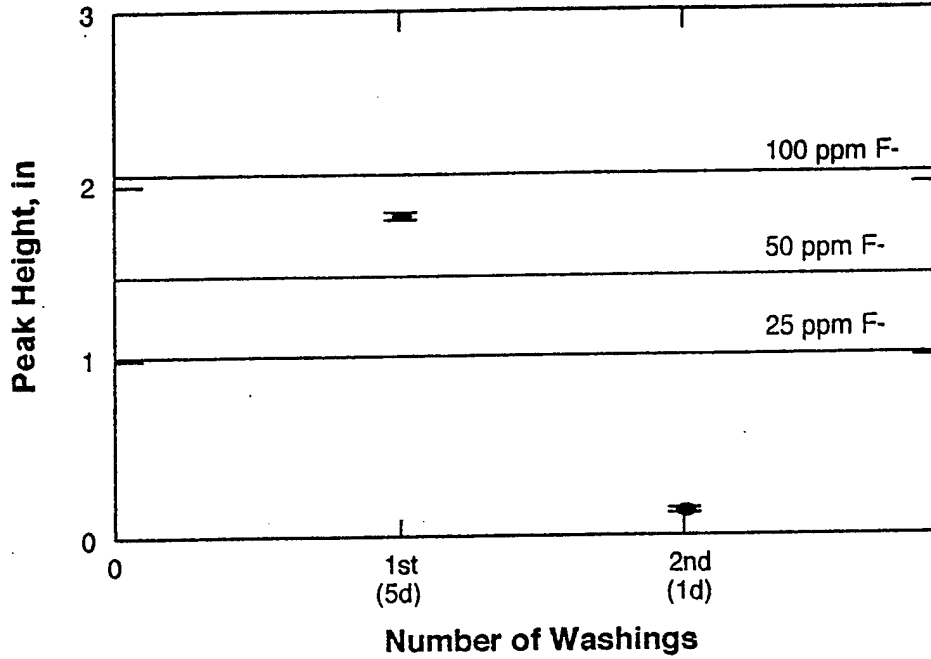
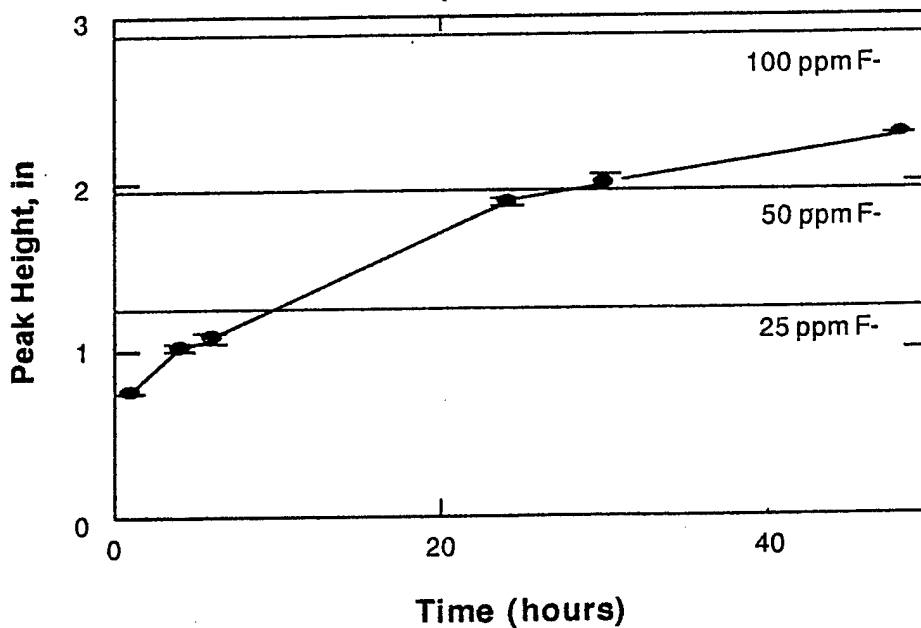

FIGURE 5

Fluoride Concentrations By Ion Chromatography During Water Washing Sample for Cell Build



Study #5 repeated examination of the experimental CF_x obtained from the consultant, Dr. Yazami. This was performed on a sample received from Dr. Yazami in December 1995. BR1225 size coin cells were made from the CF_x sample and put on test. The cells failed at high temperature storage within one day with most of the test cells having open circuit voltages (OCV) less than 2.0 volts. Results from subsequent cell teardowns and analysis indicated that the cells were severely corroded inside as was previously observed with no significant improvements.

Additional samples have been received from Dr. Yazami and other recently identified sources. Some of these materials appear encouraging at initial examination. Significant effort will be put into characterization of these materials in Phase II.

Anode Selection/Fabrication

Anode selection was relatively straight forward. Since anode materials have a limited shelf life and moderately long lead times, anode dimensional requirements were established by theoretical design calculations and fixed while efforts proceeded to design a cathode to match it. Since early cathodes were of inadequate density, the first cells were anode limited. Most recent produced cells are appropriately cathode limited with approximately 12% excess cathode based upon facing areas. In addition, the cathode is 0.1" wider than the anode to insure that cathode material is always facing the anode in the event of misalignment during the winding process.

Additional capacity could potentially be realized by tightening the cell balance, increasing the anode width slightly and achieving even higher densities. These techniques will be examined once satisfactory adhesion is achieved throughout discharge.

Finally, it was determined that a nickel tab alone is suitable as a current collector for the lithium anode. The first cells built utilized a stainless steel screen current collector but subsequent work indicated that it was not necessary for good contact and discharge uniformity and was only taking up space better utilized for active materials.

Preliminary Safety Evaluation

The safety characteristics of the present cell design have been evaluated on a preliminary basis via the following methods:

1. Bench testing of vent pressures.
2. Cell shorting tests.

It was discovered that the vents of the parts available at the time of this cell build failed to rupture at pressures over 1200 psi. The crimp of the seal would then release first. As a result, a minor modification of the vent was implemented which resulted in venting at 350 psi. Unfortunately, the modified parts were not available for incorporation into the final cell build. These vents will be utilized in the future.

An external shorting test was conducted on the cells built with unacceptable vents, test results are as follows:

1. No explosion or fire.
2. Vents did not release but header pin was pushed out and released some pressure, with bulging of the seal evident.
3. Cells reached a temperature of 100°C over about a 5 minute time period and then cooled.
4. Electrolyte leaked from around the header pin.

These results indicate that external short conditions should perform well with acceptable vents. It should also be noted that cells accidentally shorted internally during assembly heat up and ejecting electrolyte through the filler tube with no fire or ruptures occurring.

Conclusions

The technical goals for Phase I consisted of a best effort baseline cell design using off the shelf materials, processing and assembly techniques. The goals of this Phase were met but additional improvements can be made to improve the performance of the cell design to meet the long term program goals. In summary, the following conclusions apply to the cell development efforts of the program:

- Baseline cell design is complete. One hundred cells have been built for the current design and evaluated on a comprehensive test program.
- The design as presently implemented utilizes a spiral wound construction with a case negative design.
- Cathode is coated onto an aluminum foil substrate using a 5% PVDF binder.
- Seal design consists of a polypropylene header with a stainless steel feed through and ball seal for the fill tube.
- Electrolyte is 50% 1,2-dimethoxyethane (DME), 50% Propylene Carbonate (PC): 1M LiBF₄.
- Electrode surface area is 235 cm² for the anode and 245 cm² for the cathode.
- Assessment of Phase I performance is complete.
- Current performance yields approximately 2.2 Ahr typical out of the cell with a best performance of 2.3 Ahr. This compares with a final goal of the cell design is 2.3 Ahr or greater. Cell design theoretical is 2.46 Ahr.
- Low temperature (28°F) and higher rate performance has been very good and exceeds expectations.
- The shortfall in cell capacity of early cell builds was a result of problems with maintaining cathode integrity during discharge due to loss of adhesion to the cathode substrate, but this has been resolved.
- A majority of the development effort of Phase I was in the area of improving cathode adhesion and fabricating handleable electrodes.
- Further efforts in Phase II are to be examining the use of additional processing and binder modifications and evaluation of a bobbin construction.
- Initial samples of Yazami produced CF_x were evaluated and found to be unacceptable due to heavy corrosion of internal components. Corrosion is

indicative of HF inside the cell. CF_x was washed as per Dr. Yazami to eliminate metal fluoride compounds which could be producing HF and was also unsuccessful to date. Other CF_x material received in January from Dr. Yazami also proved to unacceptable once coin cells were made and tested.

- New materials recently made available from Dr. Yazami will be evaluated shortly. Sample CF_x materials produced by other sources have been received and are being evaluated and reported in Phase II.
- Two studies are in progress to evaluate corrosion of Aluminum and stainless steel against the cathode in coin cells, to be reported upon in Phase II.
- Several potential improvements to the cell design have been identified. These improvements focus on areas of cathode design, alternative binder and cathode materials, redesign of the seal for improved safety performance, changes in current collector substrate, non-magnetic construction, and evaluation of alternative electrolyte systems.
- Initial safety evaluations determined that the vents were not releasing properly and a modification was made that now produces acceptable vents and seals. Despite the substandard vents, cells behaved in a controlled manner during short circuit tests. Additional testing is planned with the revised vents in Phase II.

Because of the many advantages of the Li/ CF_x system, we feel it is the ideal system to develop as a universal AA-cell technology for the Navy's applications. The Li/ CF_x chemistry provides excellent energy density which is a key requirement of the applications.

Other major advantages of the lithium/carbon-monofluoride system (Li/ CF_x) over other lithium battery systems are in their safety, shelf life, high temperature stability, and reliability. Li/ CF_x coin cells are routinely tested by Rayovac at temperatures up to 140°C with several weeks of performance available. This compares to Li/ MnO_2 coin cells which typically cannot survive even one week at temperatures of 95°C or higher.

In addition to safety, the Li/ CF_x system has demonstrated outstanding long life stability at both room and elevated temperatures. Long term (ten year) storage tests on coin cells have shown the self-discharge rates of Li/ CF_x cells to be less than 0.5 percent per year at room temperature and less than four percent at 70°C. These self-discharge rates are lower than for any other lithium system. The excellent stability of this system is largely attributed to the fact that CF_x is completely insoluble in organic electrolyte solutions.

To achieve a reliable and safe technology, it is essential that cells be constructed from materials that are completely compatible and stable in the chemical environment within the cell. Therefore, the identification and exclusive use of the proper types of grid, tab and case materials, separators, binders, etc., are a very important part of this contract. Further work will be concentrated upon in these specific areas and will be reported in the future.