



# COMPARISON OF AIRCRAFT MANEUVER COMPENSATORS FOR ANTISUBMARINE WARFARE MAGNETOMETERS

DTIC QUALITY INSPECTED 2

Walter L. Harriman  
Sensors and Avionics Technology Directorate  
NAVAL AIR DEVELOPMENT CENTER  
Warminster, Pennsylvania 18974

Paul H. Palosky  
SEMCOR Inc.  
Strawbridge Lake Office Building  
Moorestown, New Jersey 08057

2 MARCH 1981

NADC  
Tech. Info.

19970606 032

AIRTASK NO. A5495490/001D/OW11610000  
Work Unit No. DE 101

Approved for Public Release Distribution Unlimited

Prepared for:  
NAVAL AIR SYSTEMS COMMAND  
Department of the Navy  
Washington, D.C. 20361

8100329

N O T I C E S

REPORT NUMBERING SYSTEM - The numbering of technical project reports issued by the Naval Air Development Center is arranged for specific identification purposes. Each number consists of the Center acronym, the calendar year in which the number was assigned, the sequence number of the report within the specific calendar year, and the official 2-digit correspondence code of the Command Office or the Functional Directorate responsible for the report. For example: Report No. NADC-78015-20 indicates the fifteenth Center report for the year 1978, and prepared by the Systems Directorate. The numerical codes are as follows:

CODE	OFFICE OR DIRECTORATE
00	Commander, Naval Air Development Center
01	Technical Director, Naval Air Development Center
02	Comptroller
10	Directorate Command Projects
20	Systems Directorate
30	Sensors & Avionics Technology Directorate
40	Communication & Navigation Technology Directorate
50	Software Computer Directorate
60	Aircraft & Crew Systems Technology Directorate
70	Planning Assessment Resources
80	Engineering Support Group

PRODUCT ENDORSEMENT - The discussion or instructions concerning commercial products herein do not constitute an endorsement by the Government nor do they convey or imply the license or right to use such products.

APPROVED BY: \_\_\_\_\_

DATE: \_\_\_\_\_

UNCLASSIFIED

SECURITY CLASSIFICATION OF THIS PAGE (When Data Entered)

REPORT DOCUMENTATION PAGE		READ INSTRUCTIONS BEFORE COMPLETING FORM
1. REPORT NUMBER NADC-81035-30	2. GOVT ACCESSION NO.	3. RECIPIENT'S CATALOG NUMBER
4. TITLE (and Subtitle) Comparison of Aircraft Maneuver Compensators for Antisubmarine Warfare Magnetometers		5. TYPE OF REPORT & PERIOD COVERED Final (July 80 - March 81)
		6. PERFORMING ORG. REPORT NUMBER
7. AUTHOR(s) Walter L. Harriman and Paul H. Palosky NAVAIRDEVCCEN SEMCOR, Inc. Warminster PA 18974 Moorestown, NJ 08057		8. CONTRACT OR GRANT NUMBER(s)
9. PERFORMING ORGANIZATION NAME AND ADDRESS Sensors & Avionics Technology Directorate Naval Air Development Center (Code 30) Warminster, PA 18974		10. PROGRAM ELEMENT, PROJECT, TASK AREA & WORK UNIT NUMBERS 64219N, W11610000, DE 101
11. CONTROLLING OFFICE NAME AND ADDRESS Naval Air Systems Command (Code 54902) Department of the Navy Washington, DC 20361		12. REPORT DATE 2 March 1981
		13. NUMBER OF PAGES 55
14. MONITORING AGENCY NAME & ADDRESS (if different from Controlling Office)		15. SECURITY CLASS. (of this report) Unclassified
		15a. DECLASSIFICATION/DOWNGRADING SCHEDULE
16. DISTRIBUTION STATEMENT (of this Report)  Approved for public release; distribution unlimited.		
17. DISTRIBUTION STATEMENT (of the abstract entered in Block 20, if different from Report)		
18. SUPPLEMENTARY NOTES		
19. KEY WORDS (Continue on reverse side if necessary and identify by block number) Antisubmarine Warfare Magnetic Anomaly Detection Magnetic Compensation Integrated Digital Magnetometer Compensator Group Adaptor		
20. ABSTRACT (Continue on reverse side if necessary and identify by block number) Submarines can be detected from the perturbations they cause in the earth's magnetic field. Aircraft-mounted magnetometers are used to detect these perturbations. Magnetic compensators are used to minimize the aircraft's effect upon the magnetometer signal. The Naval Air Development Center has compared the performance of two advanced magnetic compensators, the Integrated Digital Magnetometer (IDM), and the Compensator Group Adaptor (CGA), developed (continued)		

DD FORM 1473  
1 JAN 73EDITION OF 1 NOV 65 IS OBSOLETE  
S/N 0102-LF-014-6601

UNCLASSIFIED

SECURITY CLASSIFICATION OF THIS PAGE (When Data Entered)

20. ABSTRACT (Continued)

for ASW aircraft. Data for the comparison were collected on 21 test flights during the latter half of CY 1980. All test objectives were met. The compensation quality (as measured by Figure of Merit) of both systems was well within the level considered acceptable by the fleet. Residual maneuver noise left by the IDM was approximately 30% less than that of the CGA. There was no significant difference in required compensation time. A cost-effectiveness analysis is recommended.

SUMMARY

INTRODUCTION

Submarines can be detected from the perturbations they cause in the earth's magnetic field. Aircraft-mounted magnetic detecting sets, such as the AN/ASQ-81, are used to detect these perturbations. Magnetic compensators, such as the AN/ASA-65, are used to minimize the aircraft's effect upon the detecting set output.

As part of the Magnetic Anomaly Detection (MAD) Improvement Program, the Naval Air Development Center (NAVAIRDEVCCEN) has compared the performance of two advanced magnetic compensators developed for ASW aircraft: the Integrated Digital Magnetometer (IDM) and the Compensator Group Adaptor (CGA).

SUMMARY OF RESULTS

The comparison data were collected during 21 test flights, from August through November 1980, aboard P-3C aircraft BuNo 158204. Two flight origination points were used; NAVAIRDEVCCEN was the primary point, but Naval Station, Roosevelt Roads, Puerto Rico was also used to permit operations in an environment with a smaller magnetic dip angle.

A summary of the test objectives and conclusions is presented in Table S-I.

Parameters used to assess the quality of the aircraft magnetic compensations are:

- o Figure of Merit (FOM),
- o Peak-to-peak noise during straight and level flight,
- o Peak-to-peak noise during turns, and
- o Time required to compensate aircraft.

The results of these assessments are presented in Table S-II.

TABLE S-I. TEST OBJECTIVES AND CONCLUSIONS

Objectives	Conclusions
To check out the CGA and its interface with other aircraft subsystems.	Equipment adjustment and checkout was completed by mid-October 1980.
To verify that both the CGA and IDM can function successively during the same flight. That is, to verify that successful transitions between compensation systems can be accomplished during a flight.	Successful transitions were demonstrated by mid-October 1980.
To assess the quality of CGA and IDM compensations with no more than 4 cycles of each maneuver on each heading.	Both systems are capable of compensating the MAD equipment sufficiently to yield a figure of merit (FOM) less than 1.0 $\gamma$ . This is possible with no more than 4 cycles of each maneuver.
To assess the CGA performance when no IDM vector magnetometer is installed in the aircraft.	Presence of the IDM vector magnetometer does not degrade CGA performance.
To assess the CGA performance when its vector magnetometer is moved to the P-3C boom from the cabin.	No CGA improvement is effected when its vector magnetometer is installed in the P-3C boom.
To assess the quality of compensations in areas of small magnetic dip angle.	Although compensation quality at dip angles of 41° to 48° were 35%-40% poorer than that achieved at 67°, it was still acceptable. The comparison is summarized in Table S-II.
To evaluate at low altitudes the validity of compensations made at high altitudes. To assess the effect of a high-low-high altitude-change cycle upon the FOM.	Altitude changes had no appreciable effect upon compensation quality.
To assess the degradation in compensator FOM during several hours of tactical maneuvers.	Tactical maneuvers did not affect compensation quality appreciably.
To assess the effect of sonobuoy launches on aircraft compensation.	No appreciable degradation was caused by dropping 77 sonobuoys.
To assess the detection capabilities of the two systems.	Passes over a cargo ship produced easily detected signals with both systems.
To collect data suitable for testing the compatibility of the two systems with MADTACS (MAD Tracking and Compensation system).	Data suitable for future MADTACS testing were collected.

TABLE S-II. COMPENSATOR QUANTITATIVE ASSESSMENTS

Parameter	IDM		CGA	
	Mean	Standard deviation	Mean	Standard deviation
FOM at 41°-48° magnetic dip angle ( $\gamma$ )	0.63	0.14	0.88	0.06
FOM at 67° magnetic dip angle ( $\gamma$ )	0.46	0.12	0.65	0.08
FOM (all test flights) ( $\gamma$ )	0.50	0.14	0.71	0.13
Daisy-leg* average peak-to-peak noise at 14,500-ft altitude ( $\gamma$ )	0.043	0.022	0.045	0.015
Daisy-leg* average peak-to-peak noise at 500-ft altitude ( $\gamma$ )	0.055	0.018	0.055	0.011
Maximum peak-to-peak turn noise ( $\gamma$ ) <sup>†</sup>	0.21	0.07	0.30	0.14
Compensation maneuver time (min)	11.0	2.5	9.2	1.0
Total compensation time (min)	14.4	2.4	14.0	1.5

\* One-minute segments of straight and level flight on magnetic headings of 000°, 045°, 090°, 135°, 180°, 225°, 270°, and 315°.

† Measured during 1.2-mmi radius, 225° turns between successive daisy legs.

FOM values are calculated from data recorded during "boxes"; each box is a series of four aircraft runs on the four cardinal headings under control of an aircraft maneuver programmer during which specified pitch ( $+3^\circ$ ), roll ( $+10^\circ$ ), and yaw ( $+5^\circ$ ) maneuvers are performed. The sum of the average peak-to-peak MAD signals for the 12 maneuvers is defined as the FOM. A compensation which yields an FOM measurement of less than  $1.25 \gamma$  ( $1.25 \times 10^{-5}$  gauss) is considered acceptable by the fleet.

## CONCLUSIONS

Both systems can complete acceptable compensations in less than 15 minutes. This is significantly better than the two to three hours required with the current AN/ASA-65 semiautomatic system. The IDM requires that, during the aircraft compensation procedure, each cardinal heading be maintained for at least 90 seconds. The CGA has no comparable requirement. As a consequence, the average IDM compensation maneuver time is approximately 20% greater than that of the CGA. However, the IDM term computation and insertion are completed automatically in less time than the corresponding manual CGA operations. Consequently, the difference between the total IDM and CGA compensation time averages (14.4 min and 14.0 min, respectively) is insignificant.

The IDM residual noise measurements taken during maneuvers averaged approximately 30% less than those of the CGA. It is reasonable to assume that during tactical maneuvers, the maximum detection range obtainable with each compensator is inversely proportional to the cube root of that compensator's FOM. Under this assumption, the mean FOM values of Table S-II indicate that the IDM will enable detection of a target at a range of approximately 10% greater than that of the CGA.

Noise measurements taken without maneuvers showed insignificant differences between the IDM and the CGA; during straight and level flight, the need for and the impact of maneuver compensation is minimal.

Sufficient digital data have been collected during the MAD compensator comparison flight tests to enable extensive computer analyses. These include the following scheduled analyses:

- o Determining the rms magnitude of CGA and IDM residual noise during a variety of maneuvers and during straight-and-level legs;
- o Evaluating the performance of the CGA and the IDM with the MADTACS (recorded data from both systems to be played back in the laboratory and processed using the MADTACS algorithm);
- o Spectrally analyzing the compensator residual maneuver noise; and
- o Cross-correlating the compensator residual maneuver noise with aircraft dynamic signals (roll, pitch, and yaw).

A study is planned to determine the compatibility of the IDM and CGA hardware with software compensation improvements (e.g., MADTACS, Aircraft Noise Component Remover (ANCR), and Random Aircraft Maneuver Compensation (RAMAC)) currently being considered.

#### RECOMMENDATIONS

Compensation quality appeared to vary as a function of magnetic dip angle; at magnetic dip angles of  $41^\circ$  to  $48^\circ$  the measured FOMs were 35% to 40% larger than those obtained at a dip angle of  $67^\circ$ . It is recommended that further measurements at dip angle extremes be taken to determine the extent of this phenomenon.

It is recommended that a cost effectiveness comparison of the two systems be conducted.

TABLE OF CONTENTS

<u>Section</u>		<u>Page</u>
	SUMMARY	iii
	LIST OF TABLES	ix
	LIST OF ILLUSTRATIONS	x
	ACKNOWLEDGEMENT	xi
1	INTRODUCTION	1-1
2	EQUIPMENT DESCRIPTION	2-1
3	FLIGHT TEST PROCEDURES	3-1
4	COMPENSATION EFFECTIVENESS	4-1
5	SENSITIVITY ANALYSES	5-1
6	TARGET DETECTION RANGE	6-1
	REFERENCES	R-1

## LIST OF TABLES

<u>Table</u>		<u>Page</u>
S-I	TEST OBJECTIVES AND CONCLUSIONS	iv
S-II	COMPENSATOR QUANTITATIVE ASSESSMENTS	v
2-I	IDM PHYSICAL CHARACTERISTICS	2-5
2-II	CGA PHYSICAL CHARACTERISTICS	2-10
2-III	FUNCTIONAL DIFFERENCES BETWEEN IDM AND CGA	2-11
3-I	TEST FLIGHT OBJECTIVES	3-2
3-II	FLIGHT TEST PROCEDURES	3-3
4-I	AREA ENVIRONMENTAL NOISE	4-2
4-II	COMPENSATION AND FOM BOXES	4-3
4-III	UNCOMPENSATED FOM	4-8
4-IV	COMPENSATION QUALITY	4-9
4-V	DAISY LEG NOISE	4-11
4-VI	NOISE MEASURED DURING TURNS	4-12
4-VII	TIME REQUIRED TO COMPENSATE AIRCRAFT	4-14
4-VIII	IDM FOM PREDICTIONS	4-16
5-I	SENSITIVITY OF COMPENSATION QUALITY TO MAGNETIC DIP ANGLE	5-2
5-II	SENSITIVITY OF COMPENSATION QUALITY TO ALTITUDE CHANGES	5-2
5-III	SENSITIVITY OF COMPENSATION QUALITY TO CHANGES IN SONOBUOY LOAD	5-3

LIST OF ILLUSTRATIONS

<u>Figure</u>		<u>Page</u>
2-1	IDM Test Configuration	2-2
2-2	CGA Test Configuration	2-6
2-3	CGA Data Recording Subsystem	2-7
3-1	Aircraft Run Geometry, Cloverleaf Pattern	3-6
3-2	Aircraft Run Geometry, Daisy Pattern	3-7

ACKNOWLEDGEMENT

The authors gratefully acknowledge the assistance of the following personnel in successfully completing the Magnetic Anomaly Detection Compensator Comparison:

- o J. Duke, J. Gibbons, F. Marshall, P. Moser, G. Rose, R. Starry, S. Swyers, R. Schmitz, and J. Toner of the Naval Air Development Center;
- o R. Selby of Naval Air Test Center;
- o R. Baldwin and D. King of Texas Instruments Inc;
- o A. Clason and L. Van Der Roest of CAE Electronics Ltd; and
- o J. Wexler of Aerospace Mass Properties Analysis, Inc.

## SECTION 1

## INTRODUCTION

Airborne magnetic detection systems that are rigidly fixed to the airframe structure, such as those now aboard the P-3C and S-3A aircraft, require magnetic compensation to eliminate the effects of airframe-maneuver associated magnetic fields. These fields can be resolved into distinct vector terms at the magnetic detecting element. This resolution of terms can be performed in several different ways, but the set of 16 terms described by Paul Leliak (reference (1)) is widely used. Maneuver noise occurs whenever the aircraft deviates from straight and level flight. It is the result of the permanent, induced, and eddy current magnetic properties associated with the airframe steel structure and conducting surfaces. The magnetic terms are not of equal significance, since some of them exist at lower field intensities than others. This fact has been used by present systems, with limited success, to reduce the complexity of compensation equipment and procedures.

In the fleet today, magnetic compensation is achieved with a nine-term semiautomatic system, the AN/ASA-65. Successful operation with this system requires a skilled operator, an aircraft autopilot, and a maneuver programmer. The compensation procedure consists of a specific series of standard aircraft maneuvers ( $\pm 10^\circ$  rolls,  $\pm 5^\circ$  yaws, and  $\pm 3^\circ$  pitches)\* on magnetic cardinal headings. The correct sequence of maneuvers and headings is crucial to achieve successful magnetic compensation. Successful compensation requires a dedicated aircraft for a 2- to 3-hour flight. On the average, three successful compensation flights must be performed per month by a VP squadron. These requirements place an unrealistically high demand upon squadron resources.

---

\* Standard pitches are  $\pm 5^\circ$ ; however, this amplitude of maneuver rapidly induces airsickness and has been reduced to  $\pm 3^\circ$ .

New compensation systems that will increase the probability of success and reduce the demand for squadron resources are currently being studied. As part of the MAD Improvement Program, the Naval Air Systems Command Headquarters requested the NAVAIRDEVCEN to compare the performance of two candidate magnetic compensators on a P-3C aircraft. The two compensators are identified as the IDM AN/ASQ-162 (reference (2)) and the CGA AN/ASA-65(V)4 (reference (3)). The IDM was developed by Texas Instruments Inc. under the direction of NAVAIRDEVCEN. The CGA was developed by CAE Electronics Ltd.

Data for this comparison were collected during recent side-by-side flight tests. In this report, results obtained from an analysis of the test data are presented.

SECTION 2

EQUIPMENT DESCRIPTION

The two MAD compensators that were tested are:

- o A modified advanced development model (ADM) of the IDM and its related equipment
- o A preproduction model of the CGA and its related equipment

2.1 IDM

The IDM is a new magnetometer which replaces the AN/ASA-65 compensator and the AN/ASQ-81 magnetometer; only the magnetic sensor of the ASQ-81 is retained by the IDM.

The IDM equipment used in the test consisted of the following items:

- o IDM Amplifier/Signal Converter (Serial No. TM002)
- o IDM Vector Magnetometer
- o IDM Control Unit (Serial No. TM0001)
- o IDM Stores Control (Serial No. TM0001).

The interconnection of the IDM units to each other, to the Recording Unit, and to the P-3C associated equipment is shown in Figure 2-1.

The data collection Recording Unit installed on the test aircraft (but not intended for fleet use) contains a tape recording system compatible with the IDM and CGA systems. The following equipment is included in the unit:

- o Pertec 9-track Tape Transport
- o Tape Controller
- o Pertec NZRI Formatter

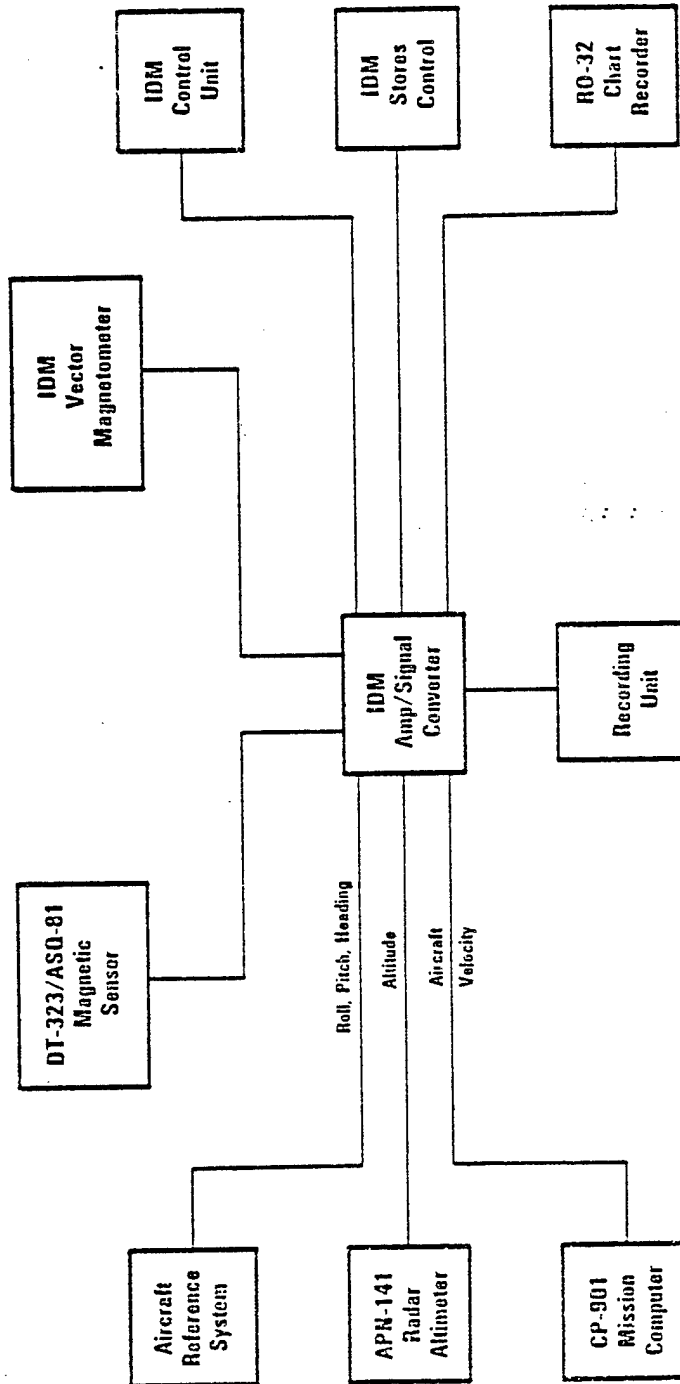

Figure 2-1. IDM Test Configuration

Equipment required for checkout of the IDM is minimal. The primary element is a "suitcase loader" which enables the necessary coded logic to be entered into the IDM amplifier/signal converter unit subsequent to installation on board the test aircraft.

The IDM Amplifier/Signal Converter receives total magnetic field data from the DT-323 Magnetic Sensor, directional magnetic field data from the Vector Magnetometer, and operator control inputs from the Stores Control and the Control Unit. The total magnetic field data are compensated using the aircraft orientation information input from the Vector Magnetometer, digitally filtered, and displayed. The Control Unit not only provides operator input but also indicates the system status and configuration. The Stores Control provides a means for inputting the aircraft's stores status so that effects due to changes in aircraft stores can be negated.

The Amplifier/Signal Converter uses a 16-bit microprocessor to control, direct, and provide the necessary arithmetic functions for the IDM system. The microprocessor's program is stored in programmable read only memory (PROM) and uses random access memory (RAM) for storing data and intermediate results. The Amplifier/Signal Converter also houses the data acquisition circuits, two external computer I/O's, and a digital recorder interface for the Recording Unit.

The IDM includes built-in test equipment (BITE). It enables the ground crew and the operator to run a complete go/no-go test. A malfunction can be isolated to a failed module.

The Recording Unit is used to record flight data as it is acquired during the flight tests. These data are recorded in digital format and include all the sensor data used by the IDM as well as control data, the display output data, a data point count, user defined analog to digital input data, and some external I/O information.

The IDM has the ability to play back these recorded data from tape so that a compensation flight can be duplicated exactly in a laboratory or slightly modified as desired. Some of the results outlined in this report were generated by using this playback technique.

The Recording Unit contains a Tape Controller, a Tape Formatter, and a Tape Transport. The Tape Controller interfaces and buffers data between the IDM and the Pertec Tape Formatter. A dual data buffer system enables the Tape Controller to receive data from the IDM using one data buffer while it transfers data from the other data buffer to the Tape Formatter. This process is reversed during data playback. The Tape Formatter generates and checks parity for the data, reformats it, and passes it to or from the Tape Transport where it is read or written on magnetic tape.

The physical characteristics of the IDM are summarized in Table 2-I. The space, weight, and power requirements listed in Table 2-I are not net increases. Because existing equipment (ASA-65 and part of ASQ-81) is superseded by IDM equipment, the net effect is actually a reduction in these requirements.

## 2.2 CGA

A block diagram of the CGA (Serial No. X002) along with the present compensation equipment is shown in Figure 2-2. Details of the CGA Data Recording subsystem are presented in Figure 2-3. The CGA Recording Unit, which is not intended for fleet use, is the same as that used by the IDM. To achieve compensation in the present ASA-65 system, the Vector Magnetometer output is correlated with the AN/ASQ-81 output to furnish information on setting the drive current to the Compensating Coils. The settings are made on the original ASA-65 Control Indicator. The values for the settings are determined from the results of the pitch, roll, and yaw maneuvers on the four cardinal headings.

TABLE 2-I. IDM PHYSICAL CHARACTERISTICS

UNIT	WEIGHT (lb/kg)	WIDTH (in/mm)	LENGTH (in/mm)	HEIGHT (in/mm)	POWER REQUIREMENTS				
					AC/DC	( $\phi$ )	(V)	(VA)	(Hz)
Amplifier/Signal Converter	64.4/29.2	14.4/366	19.09/484	8.1/206	AC	3	115/200	250	400
Vector Magnetometer	6.0/2.7	5.5/140	4.8/122	5.5/140	None	-	-	-	-
Control Unit	5.2/2.4	5.75/146	5.45/138	9.0/229	DC-Lighting Only	-	28	-	-
Stores Control	5.2/2.4	5.75/146	5.45/138	9.0/229	DC-Lighting Only	-	28	-	-

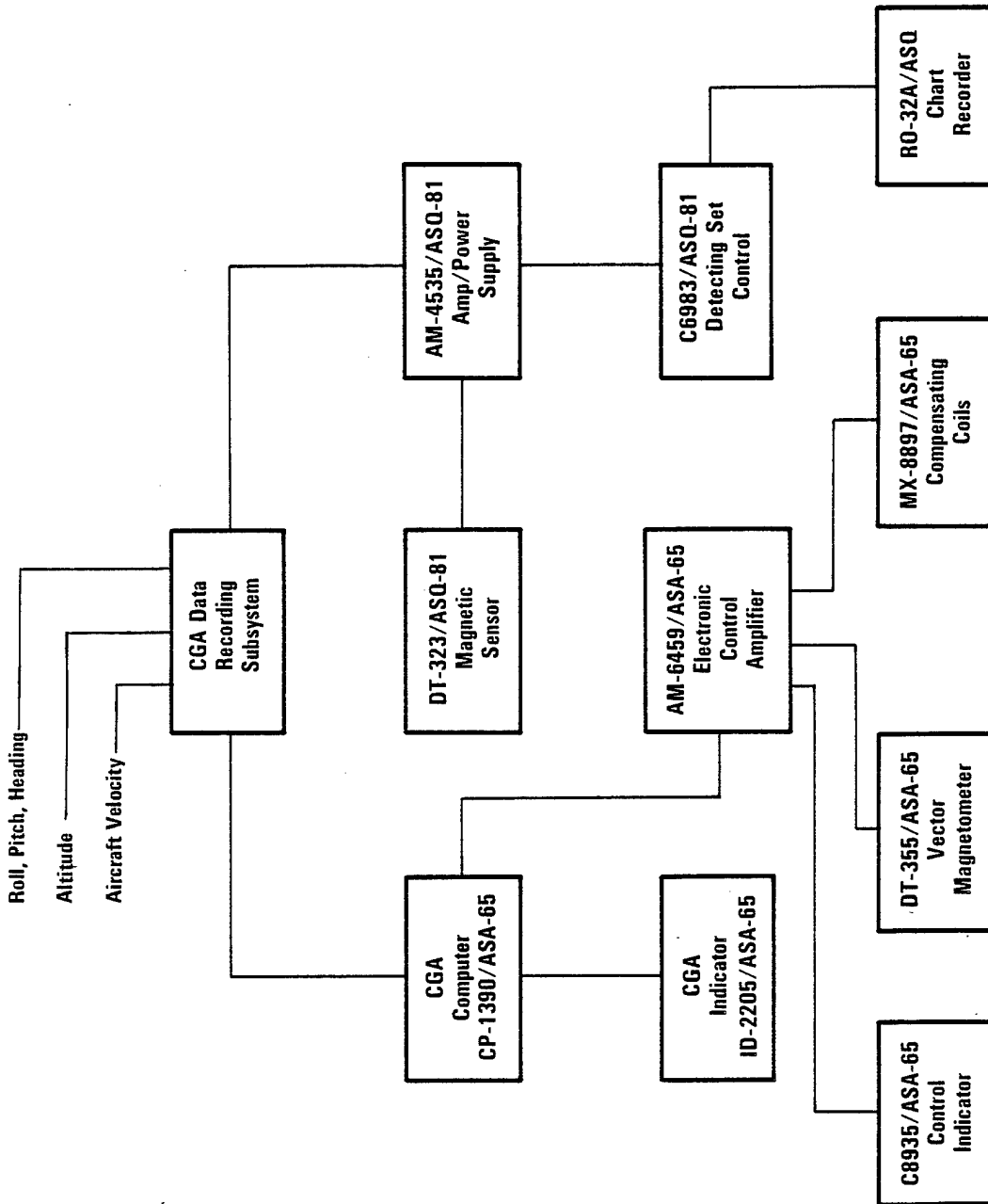

Figure 2-2. CGA Test Configuration

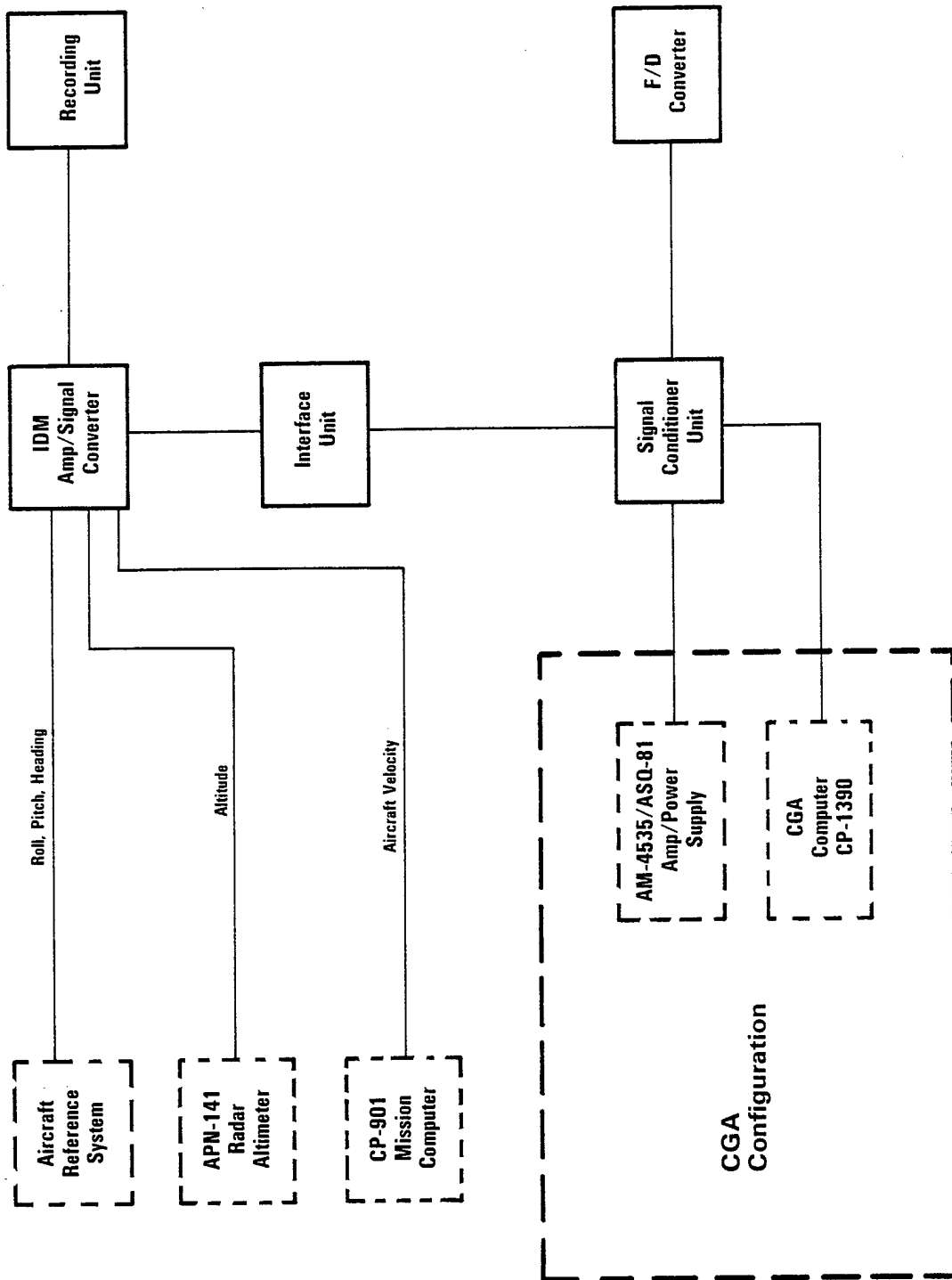

Figure 2-3. CGA Data Recording Subsystem

Note that the CGA test configuration depicted in Figures 2-2 and 2-3 does not include the following equipment:

- o MX-8109/ASA-71 Selector Control Subassembly
- o C-7693/ASA-71 Selector Control Panel
- o ID-1559A/ASA-64 Magnetic Variation Indicator

This equipment is part of the automatic submarine anomaly detection equipment included in the standard P-3C MAD suite. Since no attempt at automatic detection was scheduled during the MAD compensator comparison tests, this equipment was not used. The P-3C space it normally occupies was utilized for other test equipment.

The vector magnetometer used by the CGA is installed in the aircraft cabin. This location makes the system susceptible to noise induced by cabin material (e.g., anchor chairs and head door). The tail boom is a more appropriate location for the vector magnetometer.

The CGA includes a microprocessor in which compensation terms are computed by essentially solving 16 simultaneous equations. By using maneuvers and compensation paths different from each other, sufficient data are gathered to enable the 16 compensation terms to be determined. Of these, only the nine terms used by the ASA-65 equipment are provided. The difference in terms between what is set in the original indicator, and what is computed in the CGA is sequentially displayed by the operator in the CGA Indicator. The operator uses the differential indication displayed on the Indicator to manually adjust the terms of the ASA-65 Control Indicator to the corrected value.

In addition to the revised compensation technique, the CGA system includes a stores entry and BITE. The stores entry provides a means of compensating for the change in aircraft magnetic moment when the aircraft drops a torpedo such as the MK-46. Up to four torpedoes for the S-3A and eight torpedoes for the P-3C can be compensated for.

The BITE incorporated into the CGA Control Indicator enables the ground crew and the operator to determine total system readiness (including

the original ASA-65) before and during each flight. The type and location of any problems are designated.

The physical characteristics of the CGA are summarized in Table 2-II. The space weight, and power requirements listed in Table 2-II are net increases; no existing P-3 equipment is superseded by the CGA.

### 2.3 System Differences

Functional differences between the two systems are summarized in Table 2-III.

TABLE 2-II. CGA PHYSICAL CHARACTERISTICS

UNIT	WEIGHT (lb/kg)	WIDTH (in/mm)	LENGTH (in/mm)	HEIGHT (in/mm)	HEAT DISSIPATION (w)
CGA Computer CP-1390/ASA-65(V)	22.5/10.2	9.0/229	16.5/419	8.7/221	60 (Max) 45 (Normal)
CGA Indicator ID-2205/ASA-65(V)	3.0/1.4	5.8/147	5.4/137	3.8/97	8.5 (Max) 7.0 (Normal)

TABLE 2-III. FUNCTIONAL DIFFERENCES BETWEEN IDM AND CGA

	IDM	CGA
Number of Terms Compensated	15	9
Compensation Means	Digital Correction in Computer	ASA-65 Compensation Coils
Mode of Term Setting	Automatic	Manual
Ability of Operator to Alter Individual Terms	Not easily	Yes
Minimum Number of Headings During Compensation	4	2
FOM Predictor	Yes	No
Compensation Maneuvers	Pitch and Roll Only	Pitch, Roll, and Yaw
Type of Bandpass Filter	Digital	Analog
Availability of Digital Output Signals for Additional Digital Processing (e.g., MADTACS)	Yes	Not without additional signal conditioner
Modification Type	Supersedes existing equipment	Addition to existing equipment

SECTION 3

FLIGHT TEST PROCEDURES

The MAD compensator comparison (MADCC) tests were designed to compare the performance of the IDM and CGA magnetic compensators. The IDM and CGA systems were tested in a side-by-side configuration on P-3C aircraft, BuNo 158204. Detailed objectives are listed in Table 3-I.

To minimize variables and produce the most meaningful results, both compensators were tested and compared under similar environmental conditions in the same aircraft. The same magnetic sensor, RO-32 recorder, and data collection equipment were used by both systems. The compensators were tested sequentially under conditions as nearly identical as possible. In this way, the possibility of one system benefiting from an unfair procedural or environmental advantage was minimized.

Flight tests were conducted on 21 days, from August through November 1980, which are listed in Table 3-II. Final CGA adjustments were not completed until 14 October 1980, Flight Nine. Also indicated in this table are the specific objectives addressed on each test day and the operations conducted to meet those objectives.

Note that objective P1 is the checkout of the CGA-aircraft interface. Since the IDM-test aircraft interface had already been verified prior to the MADCC flight tests, no additional IDM interface checkout was required.

3.1 FOM Measurements

The quantity used by the fleet to describe the quality of the compensation is called the FOM. The FOM is determined by performing an FOM box (i.e., executing specified pitch, roll, and yaw maneuvers on each of the four cardinal headings) and noting the average peak-to-peak MAD signals observed at the RO-32 recorder for each maneuver. The FOM is defined as

NADC-81035-30

NADC-81035-30

TABLE 3-I. TEST FLIGHT OBJECTIVES

Code	Objective
P1	To check out the CGA and its interface with other aircraft subsystems.
P2	To verify that both the CGA and IDM can function successively during the same flight. That is, to verify that successful transitions between compensation systems can be accomplished during a flight.
P3	To assess the quality of CGA and IDM compensations with no more than 4 cycles of each maneuver on each heading.
P4	To assess the CGA performance when no IDM vector magnetometer is installed in the aircraft.
P5	To assess the CGA performance when its vector magnetometer is moved to the P-3C boom from the cabin.
P6	To assess the quality of compensations in areas of small magnetic dip angle.
P7	To evaluate at low altitudes the validity of compensations made at high altitudes. To assess the effect of a high-low-high altitude-change cycle upon the FOM.
P8	To assess the degradation in compensator FOM during several hours of tactical maneuvers.
P9	To assess the effect of sonobuoy launches on aircraft compensation.
P10	To assess the detection capabilities of the two systems.
P11	To collect data suitable for testing the compatibility of the two systems with MADTACS.

TABLE 3-II. FLIGHT TEST PROCEDURES

Flight Date	Objectives*	Procedures		CGA
		IDM		
		No. of Comp/FOM Boxes	No. of Comp/FOM Boxes	
			Other Procedures and Comments <sup>†</sup>	Other Procedures and Comments <sup>†</sup>
4 August 1980	P1	0		4
6 August 1980	P1	0		6
19 August 1980	P1	0		4
20 August 1980	P1, P2, P3	2		5
21 August 1980	P1, P2, P3	2		3
25 August 1980	P1, P2, P3	2		2
26 August 1980	P1	0		2
29 August 1980	P1, P2, P3	2		0
14 October 1980	P1, P3, P4, P5	0		9
15 October 1980	P3, P4	0		4
17 October 1980	P3, P4, P5, P11	0		1
20 October 1980	P2, P3	1		1
21 October 1980	P3	1	Noise box with towed bird	3
28 October 1980	P3	1	Noise box and daisy with towed bird	2
29 October 1980	P3	1	Noise box and daisy with towed bird Random rolls 2 OFOMs	2

\* See Table 3-I

† See Section 3.2

TABLE 3-II. FLIGHT TEST PROCEDURES (Continued)

Flight Date	Objectives*	Procedures			Other Procedures and Comments †
		IDM		CGA	
		No. of Comp/FOM Boxes	Other Procedures and Comments †	No. of Comp/FOM Boxes	
3 November 1980	P3, P6	2	Noise box and daisy wit towed bird	3	Noise box and daisy with towed bird
4 November 1980	P3, P6	2	3 daisies with towed bird	2	2 daisies with towed bird
6 November 1980	P3, P6	2		2	
13 November 1980	P3, P7, P8	4	Altitude changes	4	Altitude changes
17 November 1980	P3, P8, P9	3	Sonobuoy drops	4	Sonobuoy drops
25 November 1980	P3, P10, P11	2	Daisy over a ship	2	Daisy over a ship Daisies and straight legs with and without altitude compensator

\* See Table 3-I

† See Section 3.2

the sum of these signals; therefore, the smaller this sum, the better the compensation. An FOM under 1.25 gamma is considered by the fleet to be acceptable (reference (5)).

Compensation quality was measured using the FOM technique during the flight-test period. The number of compensation and FOM boxes executed during each test day is indicated in Table 3-I.

### 3.2 Other Assessments

Other operations were also executed during the test flights; these are identified in Table 3-I.

Some of these operations may require explanation. For instance, a noise box is a series of four straight-and-level cardinal-heading legs, each approximately 7 minutes long, under autopilot control. An operational FOM (OFOM) is performed by executing  $\pm 10^\circ$  rolls, while negotiating a turn at a  $25^\circ$  bank angle. Tactical maneuvers were simulated by daisy and cloverleaf patterns, each having leg lengths of approximately 2 nmi. The cloverleaf and daisy patterns are illustrated in Figures 3-1 and 3-2, respectively.

In addition, a towed bird (vehicle HTM 12) containing a DT-323/ASQ-81 magnetic sensor was deployed from the test aircraft wing during the five test flights from 21 October 1980 through 4 November 1980. The towed magnetometer was used to monitor the geomagnetic and geologic noise present during those test flights. This was possible because the towed magnetometer is unaffected by the aircraft's magnetic field.

TURN RADIUS: 1.1 NMI (STD RATE TURN)

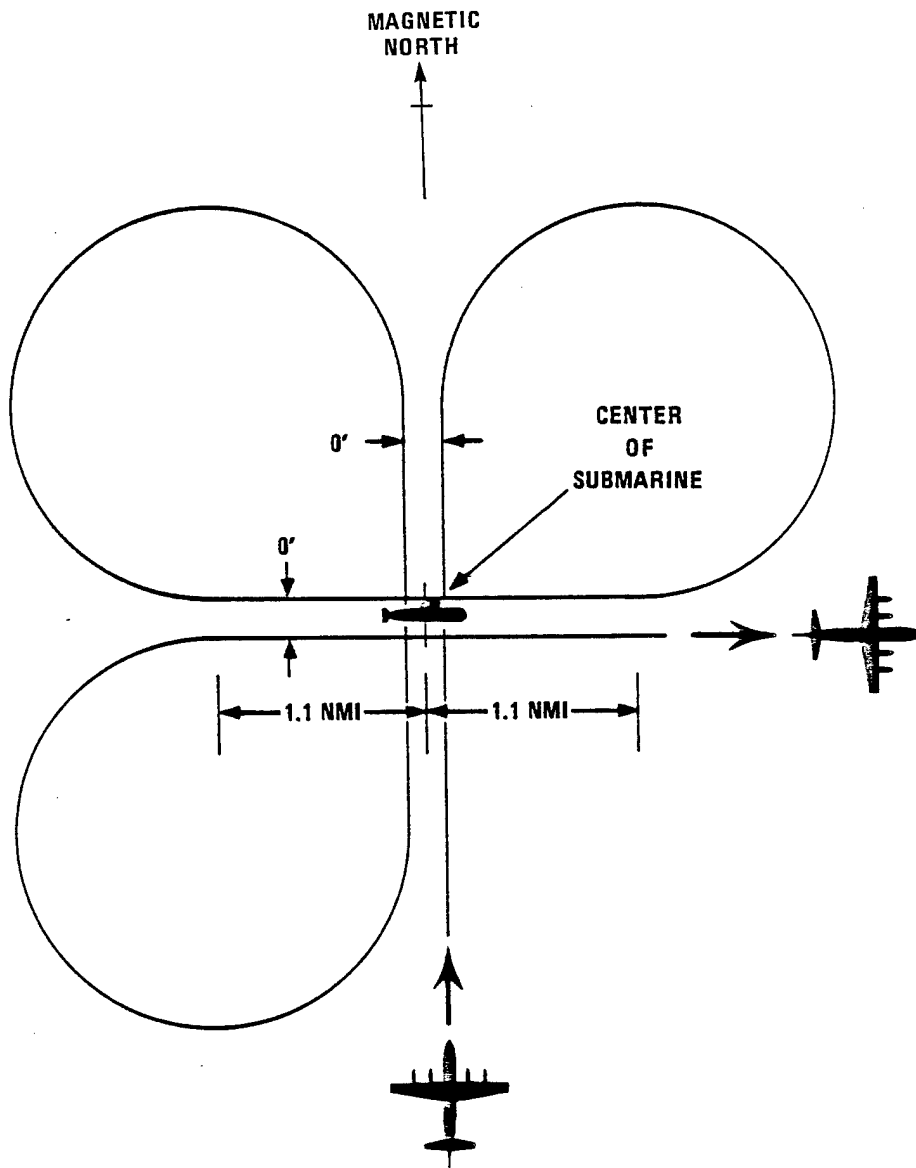

Figure 3-1. Aircraft Run Geometry, Cloverleaf Pattern

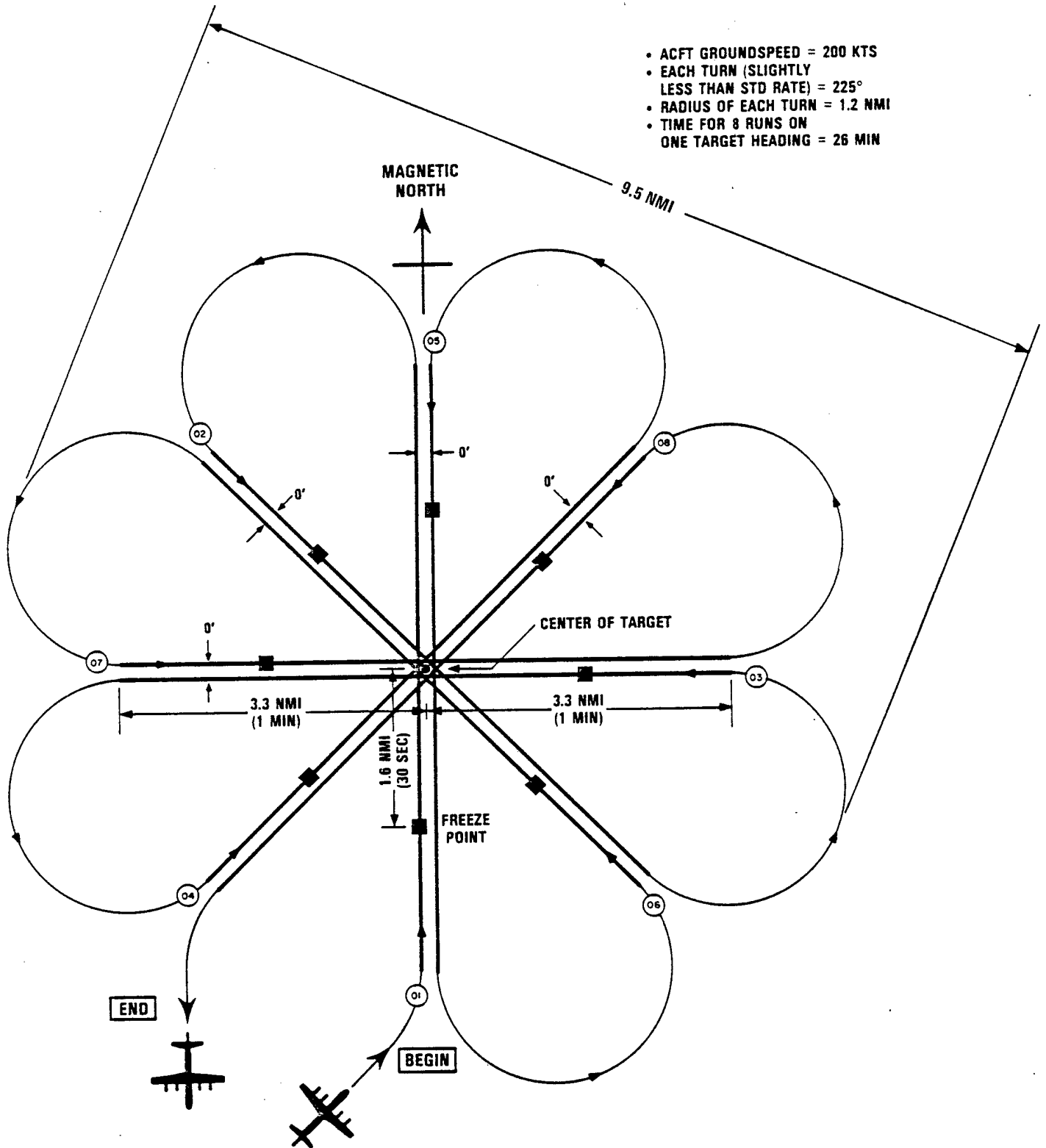

Figure 3-2. Aircraft Run Geometry, Daisy Pattern

SECTION 4

COMPENSATION EFFECTIVENESS

There are several methods of assessing the quality of aircraft magnetic compensation. In this section we examine the following parameters used to measure this quality:

- o FOM
- o Peak-to-peak noise during straight and level flight
- o Peak-to-peak noise during turns
- o Time required to compensate aircraft.

4.1 Test Area Environmental Noise

At the beginning of 17 test flights, area environmental noise was assessed. The peak-to-peak noise encountered during approximately 3-minute straight and level flights on each of the cardinal headings was measured. The average value of these measurements for each test day is presented in Table 4-I. This value is an indication of the environmental magnetic noise encountered in the test area on that day.

4.2 FOM

All compensation and FOM boxes executed during the flight tests are listed in Table 4-II. The date and location of each day's operations are listed in the first column. The boxes are numbered in the second column. Asterisks in the box column indicate that the FOM was measured by playing back data recorded during the previous compensation box. The third and fourth columns indicate the compensator type used and the operation executed during each box, respectively. The fifth column indicates the source of the compensation terms used during each box; the sixth column presents the FOM measured during that box. Comments are given, when appropriate, in the last column.

TABLE 4-I. AREA ENVIRONMENTAL NOISE

Test Day	Area Environmental Noise ( $\gamma$ )
20 August 1980	0.02
21 August 1980	0.03
25 August 1980	0.03
29 August 1980	0.03
14 October 1980	0.03
15 October 1980	0.03
17 October 1980	0.02
20 October 1980	0.02
21 October 1980	0.02
28 October 1980	0.03
29 October 1980	0.02
3 November 1980	0.03
4 November 1980	0.03
6 November 1980	0.04
13 November 1980	0.02
17 November 1980	0.02
25 November 1980	0.03
Mean	0.03
Standard Deviation	0.01

Noise levels are peak-to-peak values averaged over four straight and level cardinal heading runs.

TABLE 4-II. COMPENSATION AND FOM BOXES

Date/Loc	Box	Compensator	Operation	Source of Terms Used	Resulting FOM (Y)	Comments
4 Aug 80 Oak Bravo*	1	CGA	FOM/Comp	Uncompensated	10.90	
	2	CGA	FOM/Comp	Prev Comp	1.31	
	3	CGA	FOM/Comp	Prev Comp	0.94	
	4	CGA	FOM	Prev Comp	0.97	
6 Aug 80 Oak Bravo*	1	CGA	FOM/Comp	Uncompensated	12.20	
	2	CGA	FOM/Comp	Prev Comp	1.25	
	3	CGA	FOM/Comp	Prev Comp	1.01	
	4	CGA	FOM/Comp	Prev Comp	1.04	
	5	CGA	FOM/Comp	Prev Comp	1.12	
	6	CGA	FOM	Prev Comp	1.09	
19 Aug 80 Oak Bravo*	1	CGA	FOM/Comp	8/6/#3	0.83	
	2	CGA	FOM/Comp	Prev Comp	0.73	
	3	CGA	FOM/Comp	Prev Comp	0.85	
	4	CGA	FOM	Prev Comp	0.82	
20 Aug 80 Oak Bravo*	1	CGA	FOM/Comp	Uncompensated	11.86	The operations of Boxes 1 and 2 were aborted due to large interference signals.
	2	CGA	FOM/Comp	Prev Comp	1.22	
	3	CGA	FOM/Comp	Prev Comp	0.75	
	4	CGA	FOM/Comp	Unknown	1.38	
	5	CGA	FOM	Prev Comp	0.61	
	6	IDM	FOM/Comp			
	7	IDM	FOM			
21 Aug 80 Oak Bravo*	1	CGA	FOM/Comp	Uncompensated	10.40	
	2	CGA	FOM/Comp	Prev Comp	0.96	
	3	CGA	FOM	Prev Comp	0.63	
	4	IDM	FOM/Comp	Uncompensated	10.10	yaw terms not included in FOM of Box 4.
	5	IDM	FOM	Prev Comp	0.39	

TABLE 4-II. COMPENSATION AND FOM BOXES (Continued)

Date/Loc	Box	Compensator	Operation	Source of Terms Used	Resulting FOM (Y)	Comments
25 Aug 80 Oak Bravo*	1	CGA	FOM/Comp	Fleet Avg	4.72	
	2	CGA	FOM	Prev Comp	1.02	
	3	IDM	FOM/Comp	Prev Comp	0.51	
	4	IDM	FOM	Prev Comp	0.44	
26 Aug <sup>+</sup> WA 107	1	CGA	FOM/Comp	8/25/#1	1.53	
	2	CGA	FOM	Prev Comp	1.05	
29 Aug 80 Oak Bravo*	1	IDM	FOM/Comp	Uncompensated	10.70	West yaw term not included in
	2	IDM	FOM	Prev Comp	0.33	FOM of Box 1.
14 Oct 80 Oak Bravo*	1	CGA	FOM/Comp	Fleet Avg	5.59	
	2	CGA	FOM	Prev Comp	0.95	
	3	CGA	FOM/Comp	Uncompensated	9.75	
	4	CGA	FOM/Comp	Prev Comp	1.73	
	5	CGA	FOM	Prev Comp	0.88	
	6	CGA	FOM/Comp	Uncompensated	8.97	
	7	CGA	FOM/Comp	Prev Comp	1.53	
	8	CGA	FOM	Prev Comp	0.73	
	9	CGA	FOM	Prev Comp	0.62	
15 Oct 80 Oak Bravo*	1	CGA	FOM/Comp	Fleet Avg	0.60	
	2	CGA	FOM/Comp	Uncompensated	7.89	
	3	CGA	FOM/Comp	Prev Comp	1.06	
	4	CGA	FOM	Prev Comp	0.58	
17 Oct 80 Oak Bravo*	1	CGA	FOM	10/14/#7	0.63	
20 Oct 80 Oak Bravo*	1	CGA	FOM	10/15/#3	0.72	
	2	IDM	FOM/Comp	Prev Comp	1.21	
	*	IDM	FOM	Prev Comp	0.42	Playback of Box 2 data.
	*	IDM	FOM	Uncompensated	10.58	Playback of Box 2 data.

TABLE 4-II. COMPENSATION AND FOM BOXES (Continued)

Date/Loc	Box	Compensator	Operation	Source of Terms Used	Resulting FOM (Y)	Comments
21 Oct 80 Oak Bravo*	1	CGA	FOM/Comp	Uncompensated	10.13	
	2	CGA	FOM/Comp	Prev Comp	1.41	
	3	CGA	FOM	Prev Comp	0.68	
	4	IDM	FOM/Comp	Uncompensated	9.92	Yaw terms not included in FOM of Box 4.
28 Oct 80 Oak Bravo*	1	IDM	FOM/Comp	Prev Comp	0.94	
	2	CGA	FOM/Comp	Prev Comp	0.96	
	3	CGA	FOM	Prev Comp	0.65	
	*	IDM	FOM	Prev Comp	0.59	Playback of Box 1 data.
29 Oct 80 Oak Bravo*	1	IDM	FOM/Comp	Prev Comp	0.91	
	2	CGA	FOM/Comp	Prev Comp	0.79	
	3	CGA	FOM	Prev Comp	0.68	
	*	IDM	FOM	Prev Comp	0.39	Playback of Box 1 data.
3 Nov 80 Lat - 18 Long - 65 Dip = 48	1	IDM	FOM/Comp	Uncompensated	10.77	North yaw terms not included in FOM of Box 1.
	2	IDM	FOM	Prev Comp	0.74	
	3	CGA	FOM/Comp	Uncompensated	9.20	
	4	CGA	FOM/Comp	Prev Comp	1.17	
	5	CGA	FOM	Prev Comp	0.84	
4 Nov 80 Lat - 19 Long - 64 Dip = 48	1	IDM	FOM/Comp	Prev Comp	0.95	
	2	IDM	FOM	Prev Comp	0.48	
	3	CGA	FOM/Comp	Prev Comp	0.98	
	4	CGA	FOM	Prev Comp	0.95	
6 Nov 80 Lat - 13 Long - 63 Dip = 41	1	IDM	FOM/Comp	Prev Comp	1.42	
	2	IDM	FOM	Prev Comp	0.68	
	3	CGA	FOM/Comp	Unknown	1.16	
	4	CGA	FOM	Prev Comp	0.86	

TABLE 4-II. COMPENSATION AND FOM BOXES (Continued)

Date/Loc	Box	Compensator	Operation	Source of Terms Used	Resulting FOM (Y)	Comments
13 Nov 80 Oak Bravo*	1	CGA	FOM/Comp	Unknown	5.23	
	2	CGA	FOM/Comp	Prev Comp	0.80	
	3	IDM	FOM/Comp	Prev Comp	7.35	
	4	IDM	FOM	Prev Comp	0.36	
	5	IDM	FOM	Prev Comp	0.48	
	6	CGA	FOM	Prev Comp	0.76	
	7	CGA	FOM	Prev Comp	0.77	
	8	IDM	FOM	Prev Comp	0.57	
17 Nov 80 Oak Bravo*	1	IDM	FOM/Comp	Prev Comp	0.75	
	2	CGA	FOM/Comp	Prev Comp	1.08	
	3	CGA	FOM	Prev Comp	0.57	
	4	CGA	FOM	Prev Comp	0.79	
	5	IDM	FOM	Prev Comp	0.54	
	6	IDM	FOM	Prev Comp	0.47	
	7	CGA	FOM	Prev Comp	0.61	
	*	IDM	FOM	Prev Comp	0.67	Playback of Box 1 data.
25 Nov 80 Oak Bravo*	1	CGA	FOM/Comp	Prev Comp	0.81	
	2	CGA	FOM	Prev Comp	0.56	
	3	IDM	FOM/Comp	Prev Comp	0.81	
	4	IDM	FOM	Prev Comp	0.41	

\* Oak Bravo: 36°N Lat, 72°W Long, 67° Dip angle

† WA 107: 39°N Lat, 73°40'W Long, 68° Dip angle

Several FOMs of the uncompensated aircraft were measured. These FOMs are summarized in Table 4-III; they can be compared with the FOMs of compensated aircraft. The IDM, unlike the CGA, does not require yaw maneuvers for compensations. As a consequence, some of the IDM uncompensated FOMs do not include the contribution of yaw terms.

The FOMs of compensated aircraft are, of course, significantly lower. These FOMs are presented in Table 4-IV.

Note that CGA data prior to Box 6 of 14 October 1980 are not included in Table 4-IV. Before then, the CGA was not completely adjusted; the resulting FOMs were, therefore, abnormally high.

The FOMs of partially compensated aircraft are not included in Table 4-IV; that is, if more than one iteration was required to compensate the aircraft adequately, the FOM resulting from only the final iteration is included in this table.

No more than one iteration was required to fully compensate the IDM system. Two iterations were required with the CGA equipment when the initial term values were set to 500 (uncompensated). However, when the initial term values were set to the fleet average, or were left at the previous flight's values, only one iteration was required.

Note that the average IDM FOM ( $0.50 \gamma$ ) is approximately 30% less than the average CGA FOM ( $0.71 \gamma$ ). Both, however, are well below the 1.25-gamma threshold and are, therefore, considered acceptable in comparison to compensations presently executed in the fleet.

#### 4.2 Daisy Leg Noise

On 4 November 1980, after the aircraft was compensated with both systems, four daisy patterns were executed. Each system was used for a high-altitude (14,500 ft) daisy and a low-altitude (500 ft) daisy.

TABLE 4-III. UNCOMPENSATED FOM

Date	Uncompensated FOM ( $\gamma$ )	
	IDM	CGA
4 August 1980		10.9
6 August 1980		12.2
20 August 1980		11.9
21 August 1980	10.1	10.4
29 August 1980	10.7	
14 October 1980		9.8
14 October 1980		9.0
15 October 1980		7.9
20 October 1980	10.6	
21 October 1980	9.9	10.1
3 November 1980	10.8	9.2
Mean	10.4	10.2
Standard Deviation	0.4	1.4
TOTAL Mean	10.3	
TOTAL Standard Deviation	1.1	

TABLE 4-IV. COMPENSATION QUALITY

Date of Compensation	Compensation Quality FOM ( $\gamma$ )	
	IDM	CGA
20 August 1980	0.61	
21 August 1980	0.39	
25 August 1980	0.44	
29 August 1980	0.33	
14 October 1980		0.68
15 October 1980		0.58
17 October 1980		
20 October 1980	0.42	
21 October 1980		0.68
28 October 1980	0.59	0.65
29 October 1980	0.39	0.68
3 November 1980	0.74	0.84
4 November 1980	0.48	0.95
6 November 1980	0.68	0.86
13 November 1980	0.36	0.80
17 November 1980	0.67	0.57
25 November 1980	0.41	0.56
Mean	0.50	0.71
Standard Deviation	0.14	0.13

The average peak-to-peak MAD noise recorded by the RO-32 Recorder for each leg of these daisies is presented in Table 4-V. Note that the noise levels during the autopilot controlled straight legs are low for both systems. As expected, the mean noise level ( $0.054 \gamma$ ) at 500 ft is somewhat (23%) higher than that ( $0.044 \gamma$ ) at 14,500 ft. This is reasonable because at the lower altitude, turbulence and geologic effects are greater.

There is only a 4% difference between the average IDM and CGA noise levels. This small difference is somewhat surprising in light of the fact that the CGA FOM ( $0.95 \gamma$ ) measured on 4 November was twice that ( $0.48 \gamma$ ) of the IDM. These results seem to indicate that during straight and level flights controlled by an autopilot, aircraft maneuvers do not significantly contribute to MAD signal noise.

#### 4.3 Turn Noise

High-altitude (14,500 ft) daisy patterns (Figure 3-2) were executed on 28 October, 29 October, 3 November, and 4 November 1980. During the 3 November flight, however, unusually large noise perturbations occurred during the IDM turns; the cause of these perturbations is still unknown. The CGA daisy was erroneously flown with right-hand turns instead of the left-hand turns indicated in Figure 3-2. For these reasons, the daisy-turn data obtained on 3 November are suspect; they are, therefore, not included in the following analysis.

Each daisy turn is  $225^\circ$  at a 1.2-nmi radius. The turning rate is slightly less than that of a standard rate turn. The maximum peak-to-peak MAD noise recorded by the RO-32 recorder for each daisy turn is presented in Table 4-VI. Note that there are only seven turns in each daisy. The missing turn is identified by a dash in Table 4-VI.

Note that, in general, the IDM compensations yielded better results during daisy turns than the CGA compensations. The mean IDM turn noise ( $0.21 \gamma$ ) is approximately 30% less than the corresponding CGA turn noise ( $0.30 \gamma$ ).

TABLE 4-V. DAISY LEG NOISE

Altitude Heading System (deg)	14,500 ft		500 ft	
	IDM	CGA	IDM	CGA
045	0.03 $\gamma$	0.03 $\gamma$	0.03 $\gamma$	0.04 $\gamma$
180	0.06	0.04	0.06	0.06
315	0.03	0.05	0.09	0.05
090	0.02	0.06	0.05	0.06
225	0.08	0.07	0.06	0.06
000	0.04	0.05	0.05	0.07
135	0.02	0.03	0.04	0.04
270	0.06	0.03	0.04	0.06
Mean ( $\gamma$ )	0.043	0.045	0.053	0.055
Standard deviation ( $\gamma$ )	0.022	0.015	0.018	0.011

Column values indicate the average peak-to-peak MAD signal noise experienced during daisy legs.

TABLE 4-VI. NOISE MEASURED DURING TURNS

Location		Oak Bravo				Puerto Rico	
Headings (deg)	Date	28 Oct 1980		29 Oct 1980		4 Nov 1980	
		IDM	CGA	IDM	CGA	IDM	CGA
From	To						
000	135	0.22 $\gamma$	0.19 $\gamma$	0.20 $\gamma$	-	0.22 $\gamma$	-
135	270	0.21	0.14	0.34	0.33 $\gamma$	0.26	0.37 $\gamma$
270	045	-	0.24	0.24	0.70	-	0.45
045	180	0.24	0.25	-	0.41	0.25	0.19
180	315	0.13	-	0.09	0.38	0.17	0.22
315	090	0.17	0.24	0.27	0.52	0.37	0.20
090	225	0.21	0.31	0.19	0.30	0.27	0.27
225	000	0.12	0.16	0.10	0.20	0.16	0.20
Mean ( $\gamma$ )		0.19	0.22	0.20	0.41	0.24	0.27
Standard Deviation ( $\gamma$ )		0.05	0.06	0.09	0.16	0.07	0.10

Column values indicate the maximum peak-to-peak MAD signal noise experienced during each turn.

The altitude for each flight was 14,500 ft

IDM Mean = 0.21  $\gamma$

CGA Mean = 0.30  $\gamma$

IDM Standard Deviation = 0.07  $\gamma$

CGA Standard Deviation = 0.14  $\gamma$

#### 4.4 Time Required to Compensate Aircraft

The quicker the aircraft can be compensated, the sooner its ASW mission can be prosecuted. It is, therefore, important to be able to effectively compensate the aircraft in a timely manner.

Table 4-VII presents the time required for each compensation completed after 14 October 1980. The earlier compensations are not considered because the systems had not yet been completely adjusted. The CGA compensation of 28 October is also omitted because of insufficient data.

Compensation time is composed of maneuver, term computation, and term insertion times. The maneuver time as well as the total compensation time is presented in Table 4-VII. The term computation and insertion processes are performed automatically by the IDM system; they are manually performed for the CGA system.

The average IDM maneuver time (11.0 min) is approximately 20% greater than that (9.2 min) of the CGA. This is true in spite of the fact that the IDM does not need the yaw maneuvers required by the CGA system. This paradoxical condition results from the different timing conditions imposed by the two systems. The IDM system requires that each cardinal heading be maintained for at least 90 s even though the actual roll and pitch maneuvers are completed before this time has lapsed. The CGA system has no minimum time requirement. Instead, it requires that all maneuvers be completed within a 10-min period. This maximum time requirement necessitates restarting a CGA compensation box from the beginning if it is interrupted. Since maneuvers cannot be conducted within clouds, cloud cover could necessitate an interruption in a CGA compensation and subsequently a re-execution of the whole compensation box. An interrupted IDM compensation can simply be resumed once the aircraft emerges from the clouds; there is no need to repeat the completed legs of the compensation box.

TABLE 4-VII. TIME REQUIRED TO COMPENSATE AIRCRAFT

Date	IDM Compensation Time (min)		CGA Compensation Time (min)	
	Maneuver	Total	Maneuver	Total
15 Oct 1980			9.3	15.8
15 Oct 1980			7.8	15.1
15 Oct 1980			8.4	15.0
20 Oct 1980	8.6	11.8		
21 Oct 1980			9.4	15.9
21 Oct 1980			10.5	16.1
28 Oct 1980	12.9	16.1		
29 Oct 1980	11.1	14.8	10.1	15.3
3 Nov 1980	10.0	13.5	8.0	12.5
3 Nov 1980			8.4	13.0
4 Nov 1980	8.9	12.4	9.0	12.2
6 Nov 1980	14.9	17.9	7.7	11.8
13 Nov 1980	13.9	17.6	9.9	13.7
13 Nov 1980			9.4	13.2
17 Nov 1980	10.3	14.2	9.9	13.4
25 Nov 1980	8.1	11.6	10.7	13.8
Mean	11.0	14.4	9.2	14.0
Standard Deviation	2.5	2.4	1.0	1.0

Total time is the time required for maneuvers, computation, and entry of the new term values into the system.

IDM times do not include any time spent in performing yaw maneuvers during compensation boxes; they are not required.

The IDM term computation and insertion are completed automatically in less time than the corresponding manual CGA operations. As a consequence, in spite of the 1.8-min maneuver advantage that the CGA system enjoys, the difference between the total IDM and CGA compensation time averages (14.4 min and 14.0 min, respectively) is insignificant.

#### 4.5 FOM Prediction

As part of its compensation computations, the IDM equipment automatically assesses the quality of the compensation being performed. That is, it predicts what the FOM value will be after the new compensation terms are inserted. The accuracy of this prediction can be assessed from the data collected during the MADCC tests.

Ten of the predictions made during the MADCC tests were checked by executing FOM boxes with the new terms. These predictions are listed in Table 4-VIII.

Note that FOM predictions are consistently low; they average approximately 37% less than the corresponding measurements. The correlation coefficient is 0.482; this implies that the prediction is not strongly correlated in a linear manner to the actual FOM.

TABLE 4-VIII. IDM FOM PREDICTIONS

Date	FOM ( $\gamma$ )	
	Predicted	Measured
25 Aug	0.28	0.44
29 Aug	0.26	0.33
20 Oct	0.34	0.42
29 Oct	0.27	0.39
3 Nov	0.31	0.74
4 Nov	0.27	0.48
6 Nov	0.36	0.68
13 Nov	0.30	0.36
17 Nov	0.30	0.54
25 Nov	0.33	0.41
Mean	0.302	0.479
Standard Deviation	0.033	0.136

Average difference = 0.177  $\gamma$

rms difference = 0.212  $\gamma$

Correlation coefficient = 0.482

SECTION 5

SENSITIVITY ANALYSES

In this section, we examine the sensitivity of IDM and CGA compensator quality to different magnetic dip angles, to altitude changes and maneuvers, and to changes in the sonobuoy load.

5.1 Magnetic Dip Angle

The three test flights of 3, 4, and 6 November 1980 originated from Naval Station, Roosevelt Roads, Puerto Rico. The magnetic dip angle at the test locations on those days varied from 41° to 48°. All other test flights originated from NAVAIRDEVCCEN; for these flights, the magnetic dip angle was approximately 67°.

The quality of the compensations performed in the two areas are compared in Table 5-I. Note that both IDM and CGA compensations degrade at the lower dip angles; the average FOMs increase by 37% and 35%, respectively. In both cases, however, the average FOMs (0.63  $\gamma$  and 0.88  $\gamma$ , respectively) at the lower dip angles are still acceptable, both being below the 1.25-gamma threshold.

5.2 Aircraft Altitude Changes and Maneuvers

On 13 November 1980, IDM and CGA compensations and FOMs at 15,000 ft were performed. The aircraft then descended to 1000 ft where FOMs were again measured. The aircraft then returned to 15,000 ft where additional FOMs were measured.

The results of this experiment are summarized in Table 5-II. Note that neither the altitude changes nor the maneuvers performed during the experiment caused the FOMs to exceed the 1.25-gamma threshold.

TABLE 5-I. SENSITIVITY OF COMPENSATION QUALITY TO MAGNETIC DIP ANGLE

Magnetic Dip Angle (deg)	41-48		67	
System	IDM	CGA	IDM	CGA
Number of Compensations	3	3	10	8
FOM Mean ( $\gamma$ )	0.63	0.88	0.46	0.65
FOM Standard Deviation ( $\gamma$ )	0.14	0.06	0.12	0.08

TABLE 5-II. SENSITIVITY OF COMPENSATION QUALITY TO ALTITUDE CHANGES

System	IDM	CGA
FOM after compensation at 15,000 ft ( $\gamma$ )	0.36	0.80
FOM after descending to 1,000 ft ( $\gamma$ )	0.48	0.76
FOM after returning to 15,000 ft ( $\gamma$ )	0.57	0.77

Data taken on 13 November 1980

### 5.3 Sonobuoy Load Changes

On 17 November 1980, the aircraft was loaded with 40 external and 37 internal sonobuoys. Upon reaching an altitude of 14,600 ft, the crew performed IDM and CGA compensations and FOMs. The external buoys were then dropped and FOMs were again measured. The internal sonobuoys were then dropped and a final pair of FOMs measured.

The results of this experiment are summarized in Table 5-III. Note that no appreciable degradation in compensation quality due to the sonobuoy drops is evident; the 1.25-gamma threshold is not exceeded.

TABLE 5-III. SENSITIVITY OF COMPENSATION QUALITY TO CHANGES IN SONOBUOY LOAD

System	IDM	CGA
FOM after compensation with 87 sonobuoys ( $\gamma$ )	0.67	0.57
FOM after dropping 40 external buoys ( $\gamma$ )	0.54	0.79
FOM after dropping 37 internal buoys ( $\gamma$ )	0.47	0.61

FOMs taken at 14,600 ft on 17 November 1980

## SECTION 6

## TARGET DETECTION RANGE

Using the FOMs presented in Section 4, we can estimate the relative detection ranges obtainable with the two compensators.

The signal amplitude  $H$  of a target at range  $R$  is inversely proportional to  $R^3$ .

$$HR^3 = k_1 \quad (6-1)$$

where  $k_1$  is the constant of proportionality.

At the maximum detectable range  $R_{\max}$ , the signal amplitude  $H$  equals the product of the noise level  $N_T$  and the minimum signal-to-noise ratio  $S_{N \min}$  which enables a specified probability of target detection at a specified false-alarm rate.

$$H = S_{N \min} N_T \quad (6-2)$$

Let us assume that the noise level  $N_T$  encountered by a particular system executing tactical maneuvers is proportional to the system figure-of-merit  $F_{OM}$ .

$$\frac{N_T}{F_{OM}} = k_2 \quad (6-3)$$

where  $k_2$  is the constant of proportionality.

By combining equations (6-1, -2, and -3), we see that, for a given value of  $S_{N \min}$ ,  $R_{\max}$  is inversely proportional to the cube-root of  $F_{OM}$ .

$$R_{\max} F_{OM}^{1/3} = k \quad (6-4)$$

where  $k$  is the constant of proportionality.

The mean IDM and CGA FOMs, as indicated in Section 4, are 0.51  $\gamma$  and 0.71  $\gamma$ , respectively. Inserting these values into equation (6-4), we find the ratio  $R_{\max \text{ IDM}}/R_{\max \text{ CGA}}$  of the IDM and CGA maximum detectable ranges during tactical maneuvers.

$$\frac{R_{\max \text{ IDM}}}{R_{\max \text{ CGA}}} = \left(\frac{0.71}{0.50}\right)^{1/3} = 1.1 \quad (6-5)$$

That is, under identical tactical-maneuver conditions, the IDM will enable detection of a target at a range of approximately 10% greater than that of the CGA.

As indicated in Section 4.1, the 0.51  $\gamma$  and 0.71  $\gamma$  FOM values were obtained in areas having an average environmental noise of 0.03  $\gamma$ . In areas exhibiting higher environmental noise levels, the relative difference between the IDM and CGA FOMs is expected to be less. Consequently, in these areas, the relative detection-range advantage of the IDM over the CGA is also expected to be less.

During actual ASW operations, pitches and yaws are rarely executed. Therefore, turn noise is probably more representative of tactical noise than that encountered during the measurement of FOMs. Note that if we assume that the noise level  $N_T$  is proportional to the mean turn noise presented in Table 4-VI instead of the mean FOM we obtain similar results.

$$\frac{R_{\max \text{ IDM}}}{R_{\max \text{ CGA}}} = \left(\frac{0.30}{0.21}\right)^{1/3} = 1.1 \quad (6-6)$$

NADC-81035-30

REFERENCES

1. "Identification and Evaluation of Magnetic Field Sources of MAD Equipped Aircraft," Paul Leliak, Sep 1961, IRE Transactions on Aerospace and Navigational Electronics.
2. "Integrated Digital Magnetometer Final Report," Report No. NADC-76109-20, Texas Instruments Inc., Dallas, Texas, 13 Apr 1978.
3. "Interim Handbook Compensator Group Adaptor (CGA)," Report No. TD 8512, CAE Electronics Ltd, Montreal, Quebec, Canada, 18 Jul 1980.
4. Lindstrom, G. M., "Test and Evaluation Considerations for MAD Compensation Techniques," Report No. 35210-2081-UX-00, TRW Systems Group, McLean, VA, 30 Apr 1980.
5. "NFO/Aircrew NATOPS Flight Manual Navy Model P-3C Aircraft," NAVAIR-01-75 PAC-1.1, 15 Jun 1977, change 4-15 Oct 1980.

DISTRIBUTION LIST

REPORT NO. NADC-81035-30

AIRTASK NO. A5495490/001D/OW11610000  
Work Unit No. DE 101

	<u>No. of Copies</u>
NAVAIR (Code 54902) . . . . .	5
DTIC . . . . .	12

8100329