

REPORT NO. NADC-79011-60



# FEASIBILITY STUDY OF A COST-EFFECTIVE COMPOSITE MATERIALS MAXIMUM PERFORMANCE ESCAPE SYSTEM SEAT

THE BUDD COMPANY TECHNICAL CENTER  
Fort Washington, Pennsylvania 19034

SEPTEMBER 1978

DTIC QUALITY INSPECTED 2

FINAL REPORT  
AIRTASK NO. WF41-400-000  
Work Unit No. ZA604

CONTRACT NO. N62269-78-C-0112

APPROVED FOR PUBLIC RELEASE; DISTRIBUTION UNLIMITED

## NADC

### Tech. Info.

Prepared for  
NAVAL AIR SYSTEMS COMMAND  
Department of the Navy  
Washington, D.C. 20361

8400265

19970605 015

## NOTICES

**REPORT NUMBERING SYSTEM** - The numbering of technical project reports issued by the Naval Air Development Center is arranged for specific identification purposes. Each number consists of the Center acronym, the calendar year in which the number was assigned, the sequence number of the report within the specific calendar year, and the official 2-digit correspondence code of the Command Office or the Functional Directorate responsible for the report. For example: Report No. NADC-78015-20 indicates the fifteenth Center report for the year 1978, and prepared by the Systems Directorate. The numerical codes are as follows:

CODE	OFFICE OR DIRECTORATE
00	Commander, Naval Air Development Center
01	Technical Director, Naval Air Development Center
02	Comptroller
10	Directorate Command Projects
20	Systems Directorate
30	Sensors & Avionics Technology Directorate
40	Communication & Navigation Technology Directorate
50	Software Computer Directorate
60	Aircraft & Crew Systems Technology Directorate
70	Planning Assessment Resources
80	Engineering Support Group

**PRODUCT ENDORSEMENT** - The discussion or instructions concerning commercial products herein do not constitute an endorsement by the Government nor do they convey or imply the license or right to use such products.

APPROVED BY:



EDWARD J. STURM  
By direction

DATE:

9 March 1979

REPORT DOCUMENTATION PAGE		READ INSTRUCTIONS BEFORE COMPLETING FORM
1. REPORT NUMBER NADC-79011-60	2. GOVT ACCESSION NO.	3. RECIPIENT'S CATALOG NUMBER
4. TITLE (and Subtitle) Feasibility Study of a Cost-Effective Composite Materials Maximum Performance Escape System Seat		5. TYPE OF REPORT & PERIOD COVERED Final Report May 1978 - September 1978
		6. PERFORMING ORG. REPORT NUMBER
7. AUTHOR(s)		8. CONTRACT OR GRANT NUMBER(s) Contract No. N62269-78-C-0112
9. PERFORMING ORGANIZATION NAME AND ADDRESS The Budd Co. Technical Center Fort Washington, Pennsylvania 19034		10. PROGRAM ELEMENT, PROJECT, TASK AREA & WORK UNIT NUMBERS 62241 N F41400, AirTask No. WF41-400-000, W.U. 7A60 4
11. CONTROLLING OFFICE NAME AND ADDRESS Naval Air Systems Command (Air-340B) Department of the Navy Washington, D.C. 20361		12. REPORT DATE
		13. NUMBER OF PAGES 65
14. MONITORING AGENCY NAME & ADDRESS (if different from Controlling Office) Naval Air Development Center Aircraft & Crew Systems Technology Directorate Warminster, Pennsylvania 18974		15. SECURITY CLASS. (of this report)  UNCLASSIFIED
		15a. DECLASSIFICATION/DOWNGRADING SCHEDULE
16. DISTRIBUTION STATEMENT (of this Report)  APPROVED FOR PUBLIC RELEASE; DISTRIBUTION UNLIMITED		
17. DISTRIBUTION STATEMENT (of the abstract entered in Block 20, if different from Report)		
18. SUPPLEMENTARY NOTES		
19. KEY WORDS (Continue on reverse side if necessary and identify by block number) Escape System Cost Effectiveness Composite Materials High Strength Lightweight		
20. ABSTRACT (Continue on reverse side if necessary and identify by block number) Ejection seats used in military aircraft are traditionally fabricated with sheet metal, formed or riveted into a bucket structure. Using conventional metal materials has several drawbacks, namely, high initial production costs required by complexity of manufacture, relatively short service life due to environmental exposure and high maintenance costs. Under the U.S. Navy's continuing search for improved escape systems, it is required to explore the potential of using advanced "state-of-the-art" materials to reduce or		

UNCLASSIFIED

SECURITY CLASSIFICATION OF THIS PAGE (When Data Entered)

20. eliminate these drawbacks. "Composite" materials and/or a combination of composite and aluminum are explored in this study and appear feasible.

UNCLASSIFIED

SECURITY CLASSIFICATION OF THIS PAGE(When Data Entered)

## FOREWORD

This technical report was prepared by The Budd Company Technical Center, Fort Washington, Pennsylvania. The Program Manager was H. A. Jahnle, Principal Engineer R. B. Freeman, Structural Designer and Analyst M. S. Frankel, and Estimator W. Klinger. Other supporting staff were R. H. Marvin and W. W. Dickhart for Program Review and A. Di Ferdinando for Secretarial Assistance.

The effort described was conducted for the Naval Air Development Center, Warminster, Pennsylvania. Mr. W. C. Ward was the Technical Coordinator and his comments along with those of Mr. M. Schulman and Mr. C. Woodward are gratefully acknowledged.

## SUMMARY

Three MPES ejection seats were evaluated for weight and cost. The three seats were the "Baseline" which corresponded to the existing prototype from a previous contract; the "Modified" which was a slight redesign of the "Baseline" to reduce cost even at the expense of increased weight; and the "Composite" version which was directed toward reducing the seat structure cost through the use of composite materials.

A decision was made based on weight, strength and stiffness considerations to use graphite fiber in the Composite version. The lightest weights for each of the three seats, where a number of options are described in the report regarding material type and component design, are as follows:

Baseline:	30.75 lbs.
Modified:	35.52 lbs.
Composite:	37.50 lbs.

The corresponding projected cost numbers for these same weight configurations are:

PRODUCTION COST PERCENTAGES INCLUDING TOOLS (BASELINE @ 100 EA =\$ MAX (100%))		
	<u>100 SEATS</u>	<u>200 SEATS</u>
BASELINE:	\$ MAX (100%)	41.% MAX
MODIFIED:	92. % MAX	37.% MAX
COMPOSITE:	81% MAX	34.% MAX

The total estimated prototype cost for one and five composite seats are \$270,000 and \$395,000 respectively. A number of potential methods for reducing the prototype costs are briefly mentioned.

The two metal Baseline and Modified ejection seats must be considered as proven structures because of the success of a tested prototype of the Baseline version. The Composite seat, on the other hand, is expected to be structurally acceptable but it does require some development effort to establish the manufacturing process.

## TABLE OF CONTENTS

	<u>Page No.</u>
Foreword.....	i
Summary.....	ii
List of Figures.....	v
List of Tables.....	vii
1.0 Introduction.....	1
2.0 Aluminum Honeycomb MPES Seat Structure.....	5
2.1 Baseline Seat.....	5
2.2 Modified Seat.....	5
3.0 Composite MPES Seat Structure.....	26
3.1 Composite Material Properties.....	27
3.2 Design Concepts.....	29
3.3 Selected Composite Design Concept.....	33
3.4 Manufacturing Process.....	37
3.5 Estimated Weight of Composite MPES Seat.....	39
3.6 Potential for Success of Composite MPES Seat.....	40
3.7 Environmental Effects.....	45
4.0 Comparison of Costs for Aluminum and Composite MPES Seats.....	54
4.1 Production Costs.....	54
4.2 Composite Prototype Costs.....	56
5.0 Recommendations and Conclusions.....	57
6.0 References.....	58

## LIST OF FIGURES

<u>Figure No.</u>		<u>Page No.</u>
1-1	MPES Ejection Seat.....	2
1-2	Prototype of the Baseline MPES Ejection Seat.....	3
2-1	Weight Increase Resulting from Modifying the Rounded Bottom of Bucket.....	6
2-2	Weight Increase Resulting from Adding an Angle Reinforcement Between the Bucket and the Seat Rails.....	7
2-3	Weight Reduction Resulting from Removing the Corner Bracket.....	8
2-4	Weight Reduction Resulting from Modifying the Back's Base Fitting.....	9
2-5	Weight Increase Resulting from Adding an Angle Reinforcement Between the Bucket Base and the Seat Back.....	11
2-6	Weight Increase Resulting from Modifying the Seat Angle Bracket.....	12
2-7	Weight Increase Resulting from Modifying the Bucket's Rear Channel Fitting.....	13
2-8	Weight Increase Resulting from Modifying the Leg Side Support.....	14
2-9	Weight Increase Resulting from Modifying the Bucket's Frame Bulkhead.....	15
2-10	Weight Increase Resulting from Modifying the Bow Channel Fitting.....	16
2-11	Weight Increase Resulting from Modifying the Bucket's Front Channel Fitting.....	17
2-12	Weight Increase Resulting from Modifying the Corner Fitting.....	18
2-13	Weight Increase Resulting from Modifying the Rail.....	20

## LIST OF FIGURES (Cont.)

<u>Figure No.</u>		<u>Page No.</u>
2-14	Weight Increase Resulting from Modifying the Bucket's Spar Fitting.....	21
2-15	Weight Increase Resulting from Modifying the Bucket Ring Fitting.....	22
2-16	Weight Increase Resulting from Modifying the Leg Side Support.....	24
2-17	Weight Increase Resulting from Modifying the Corner Fitting.....	25
3-1	Concepts for Composite Ejection Seat.....	30
3-2	Concepts for Composite Ejection Seat.....	31
3-3	Concepts for Composite Ejection Seat.....	32
3-4	Proposed Composite MPES Seat Structure.....	35
3-5	Proposed Composite MPES Seat Structure.....	36
3-6	Possible Nesting Design for Bonding Together Two Halves.....	38
3-7	Results of Trial Run Compression Molding Using HMC Ribs and Continuous Graphite Fiber/Polyester Skins.....	42
3-8	Effect of Humidity Treatments on Longitu- dinal and Shear Strength Properties.....	47
3-9	Effect of Various Humidity Treatments on Longitudinal Strength Properties.....	48
3-10	Effect of Various Humidity Treatments on Longitudinal and Shear Elastic Properties..	49
3-11	Bar Chart of Effect of Immersion on Strength Properties of AS/3501-5 Graphite/Epoxy Laminates.....	52

LIST OF TABLES

<u>TABLE NO.</u>		<u>PAGE NO.</u>
3-1	Material Allowables.....	28
4-1	Cost Estimates for Three MPES Seat Concepts.....	55

## 1.0 Introduction

An investigation into the potential of using composite materials to develop a structural concept for a "Maximum Performance Escape System" (MPES) ejection seat was performed. In a previous program sponsored by the United States Naval Air Development Center, The Budd Company developed an acceptable metal MPES seat structure, Figure 1-1, which will be compared to the composite seat on a weight and cost basis. The basic metal structure utilized a sandwich construction of aluminum honeycomb core with aluminum facings which yielded an excellent light weight structure. The structure was further enhanced by the smooth clean exterior which it presented for minimizing interferences within the cockpit. This was accomplished in part by embedding all control cables in the honeycomb structure.

The metal seat structure previously fabricated withstood the combined crash test load of 44 g and successfully passed all of the testing. This design, shown in Figure 1-2, is considered as the "Baseline" MPES seat for the current study. To consider a mass produced version of the Baseline, wherever possible, forgings, castings and extrusions were substituted and a resulting production cost established.

An alternate design to the Baseline has been developed during this study. It is considered to be the "Modified" MPES design because it is basically the baseline seat structure with some changes. The rounded corners of the bottom of the seat bucket as seen in Figure 1-2 have been replaced by square

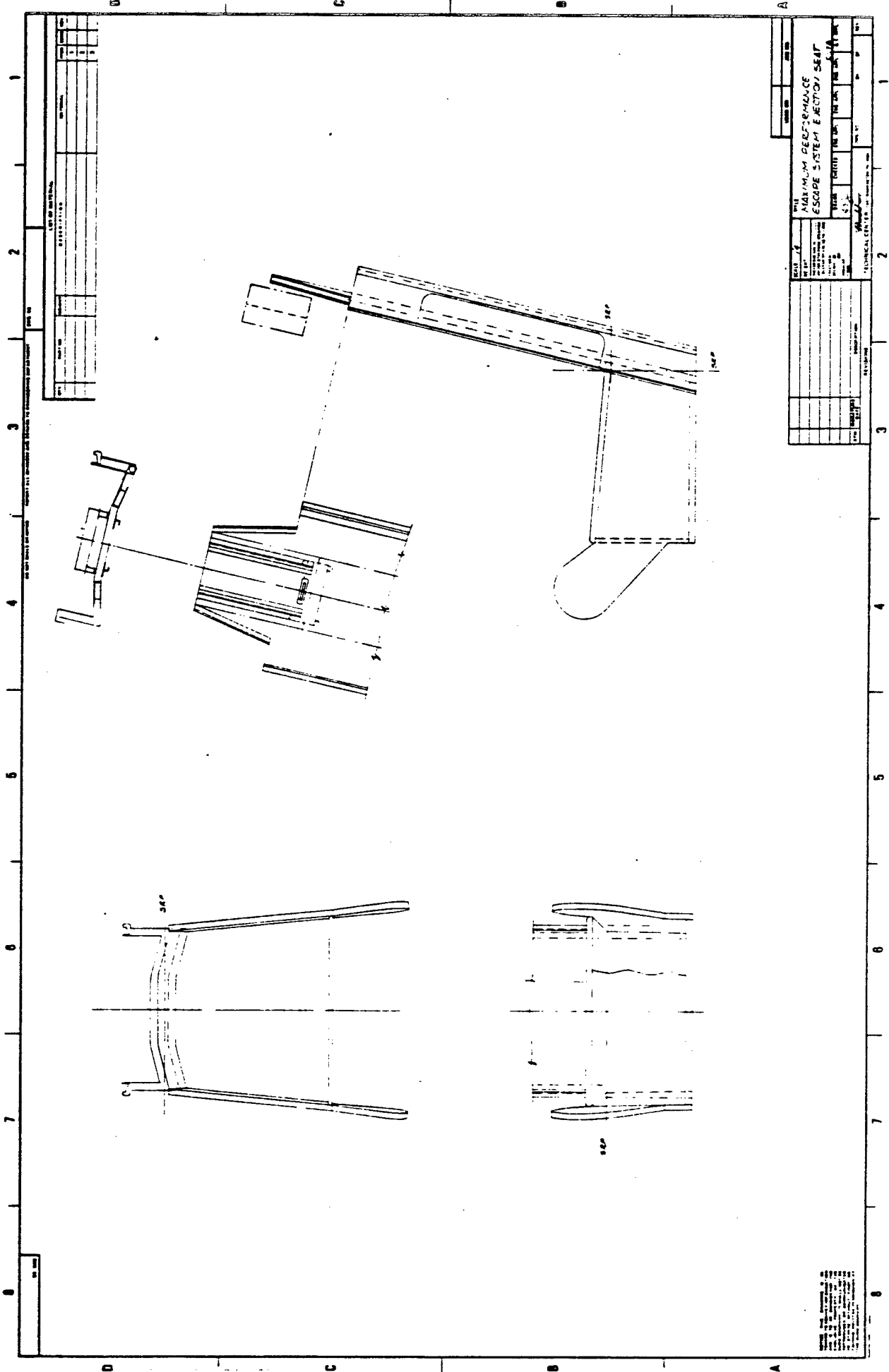

FIGURE 1-1  
MPES EJECTION SEAT

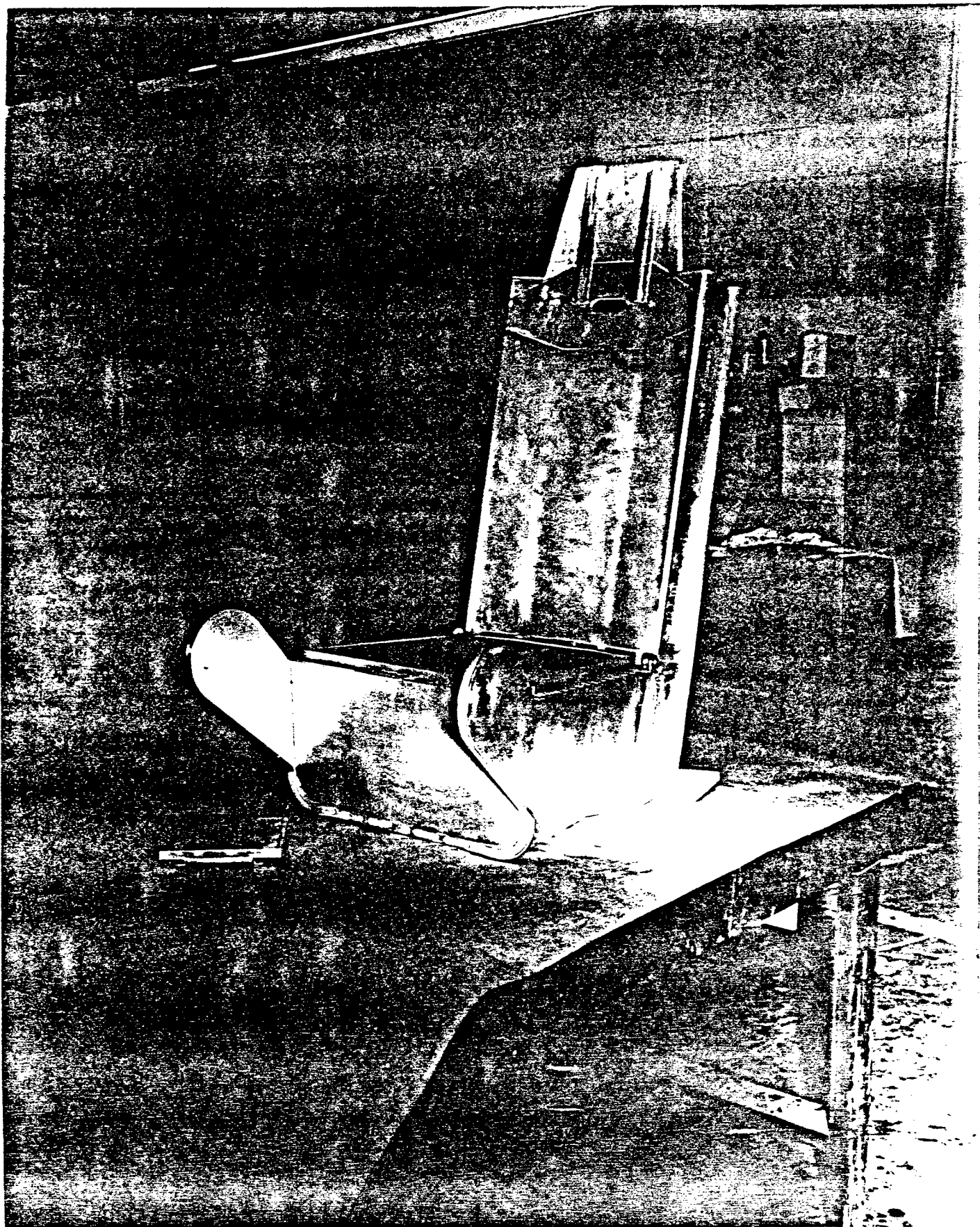

FIGURE 1-2  
PROTOTYPE OF THE BASELINE MPES EJECTION SEAT

corners and other features have been incorporated to reduce the cost of a production seat even at the expense of a weight penalty.

With the increased acceptance of the advanced composite materials for use in aerospace structures, the MPES ejection seat became a potential application. Therefore, the third version of the MPES seat to be considered is the "Composite" one. A number of fabrication techniques were considered for the Composite version with the final selection based primarily on attempting to reduce cost. The concept chosen involves the use of eleven (11) compression molded components which are subsequently bonded and riveted together. Each molding consists of continuous graphite fiber skins with chopped glass or graphite fiber ribs. The main load carrying members are aluminum extrusions or machinings which are connected to each other thus avoiding highly loaded metal-to-composite joints.

## 2.0 Aluminum Honeycomb MPES Seat Structures

### 2.1 Baseline Seat

Comparison of the three (3) types of MPES seats on both a weight and cost basis requires that they be in a production status. For the Baseline seat this would mainly involve replacing those machined fittings with forged, cast or extruded ones where possible. By possible it is meant that the existing strength must be retained especially in considering extrusions where another alloy may have to be used. Where it is not possible to retain the proper strength, then the machined fitting will be retained for the Baseline seat structure. The weight of the Baseline structure is 30.75 pounds.

### 2.2 Modified Seat

In establishing the design of the Modified seat structure, the seat bottom went from a rounded corner to a square one. This resulted in simplifying the lower attachment between the bucket and the seat back. In addition, fittings and joints were simplified. The results of this phase of the study are shown in Figures 2-1 through 2-15. Figure 2-1 shows the details involved in going to a square bottomed bucket. A 2024-T4 extrusion runs from the seat back to the front of the bucket and satisfies the corner structural requirements. The actual connection to the seat rail structure is accomplished with the 7075-T6 angle extrusion shown in Figure 2-2. This approach eliminates the fitting shown in Figure 2-3. Returning to Figure 2-2, the angle extrusion is connected to the closeout of the seat rail structure. This closeout, which used to run across the entire back and rail support has been modified to just include the rail area as displayed in Figure 2-4.

FIGURE 2-1

Weight Increase Resulting From Modifying The  
Rounded Bottom Of Bucket (Ref. Budd Dwg. J2545-101000)

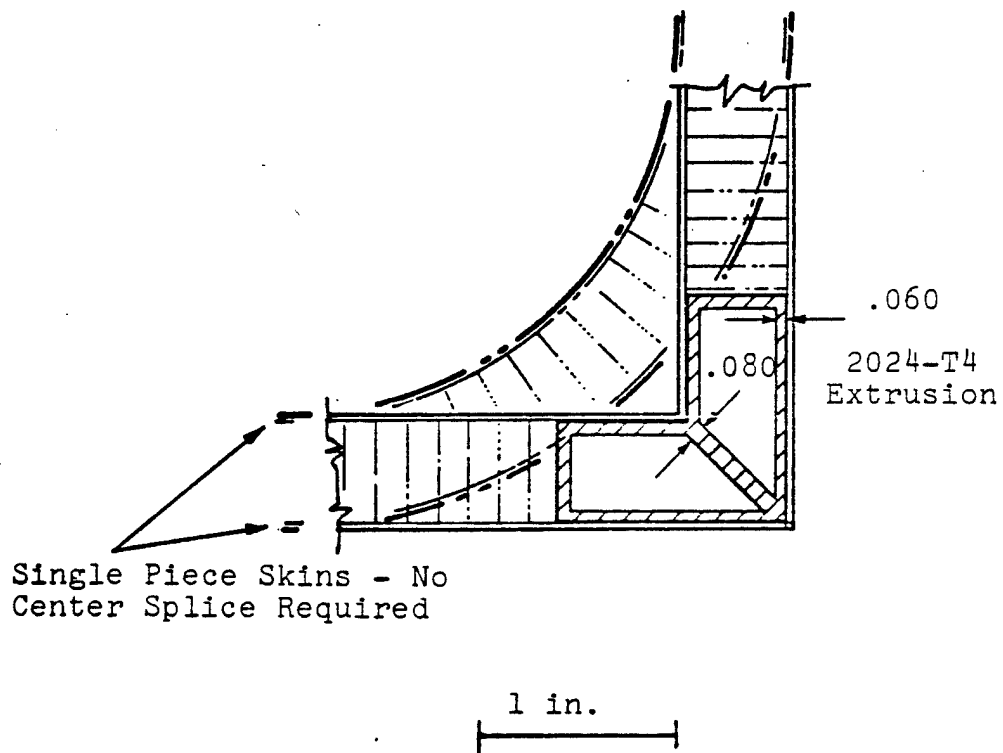

Increase In Weight Per Seat: 0.966 lb.

FIGURE 2-2

Weight Increase Resulting From Adding An Angle Reinforcement Between The Bucket And The Seat Rails (Ref. Budd Dwg. J2545-101000)

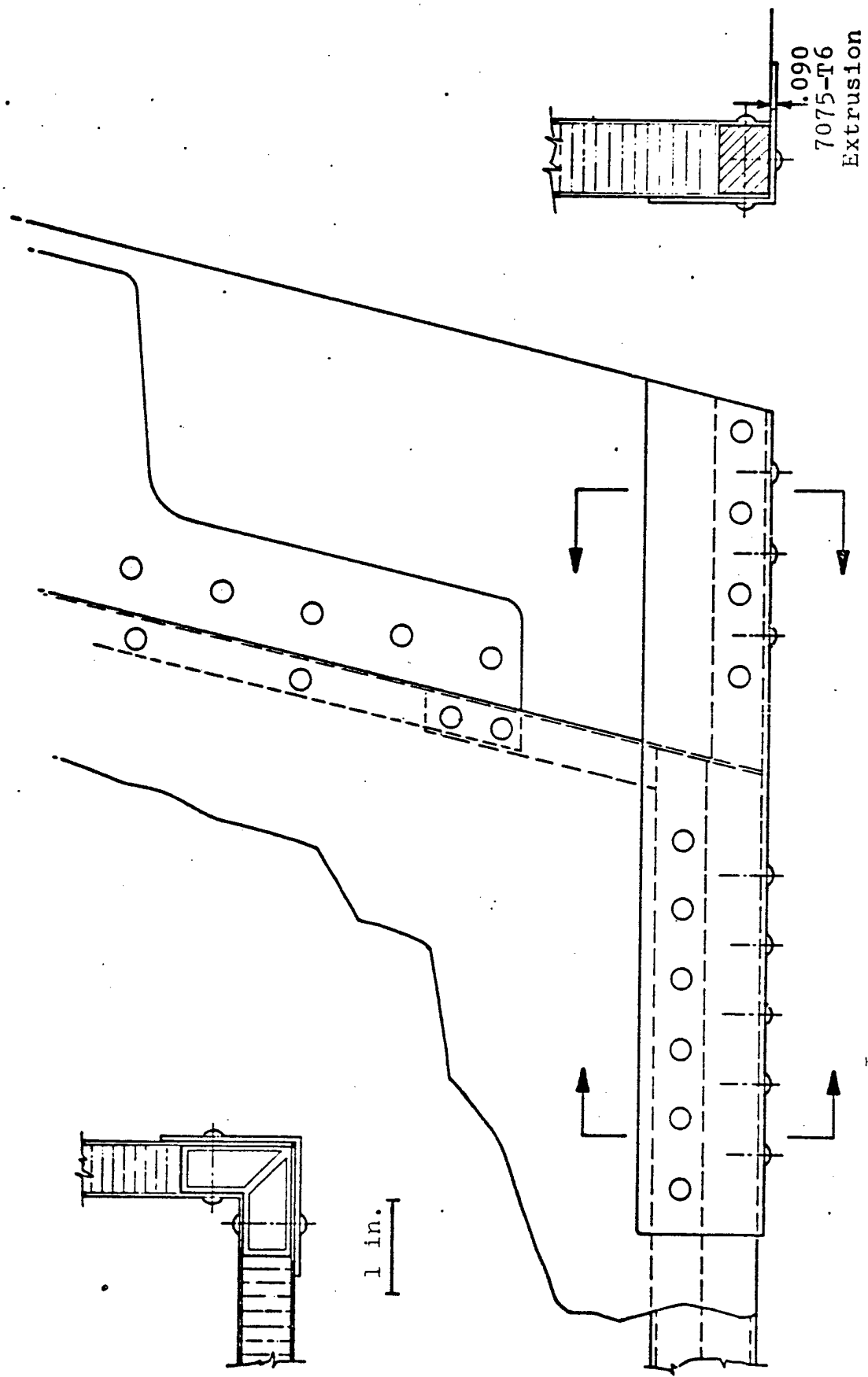
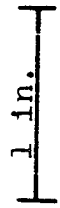
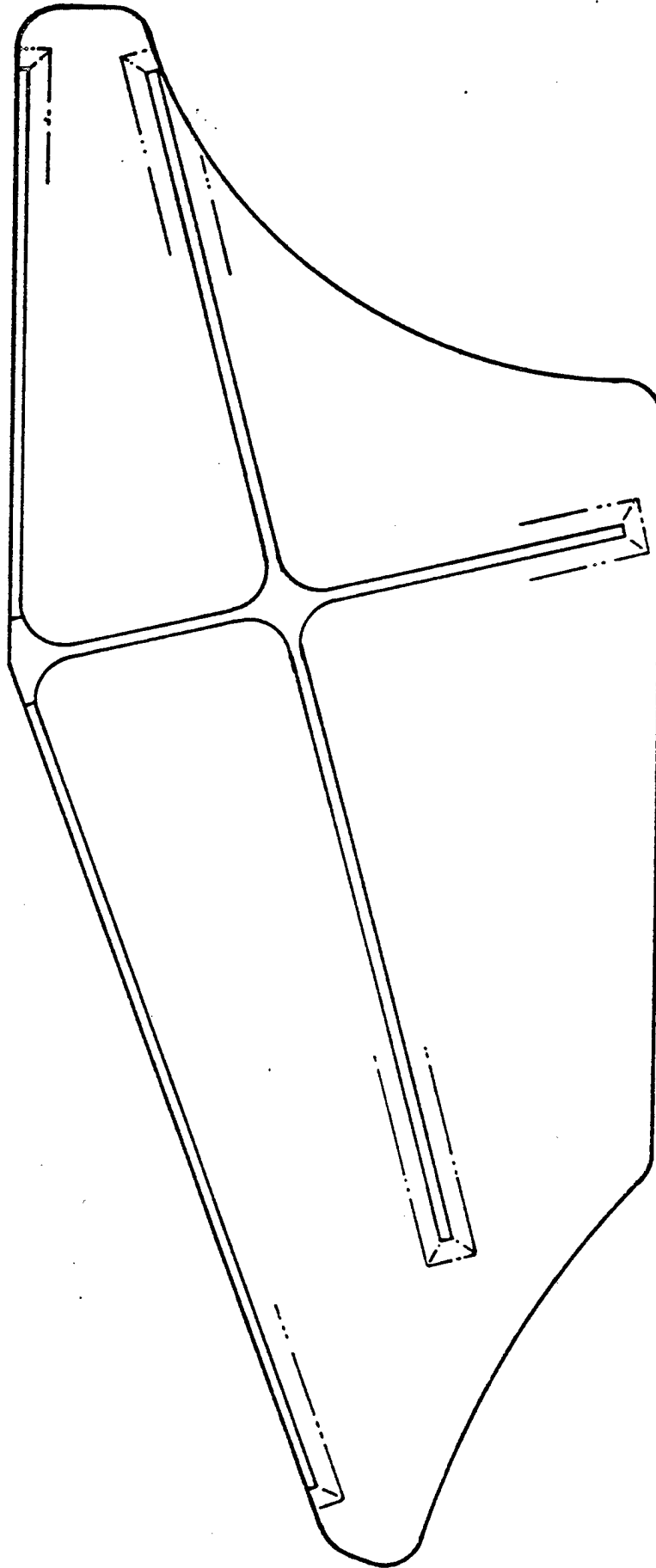

FIGURE 2-3

Weight Reduction Resulting From Removing The Corner Bracket (Ref. Budd Dwg. D2379-0019 & 20)



Decrease In Weight Per Seat: 0.437 lb.

FIGURE 2-4

Weight Reduction Resulting From Modifying The Back's  
Base Fitting (Ref. Budd Dwg. D2379-0017 & 0018)

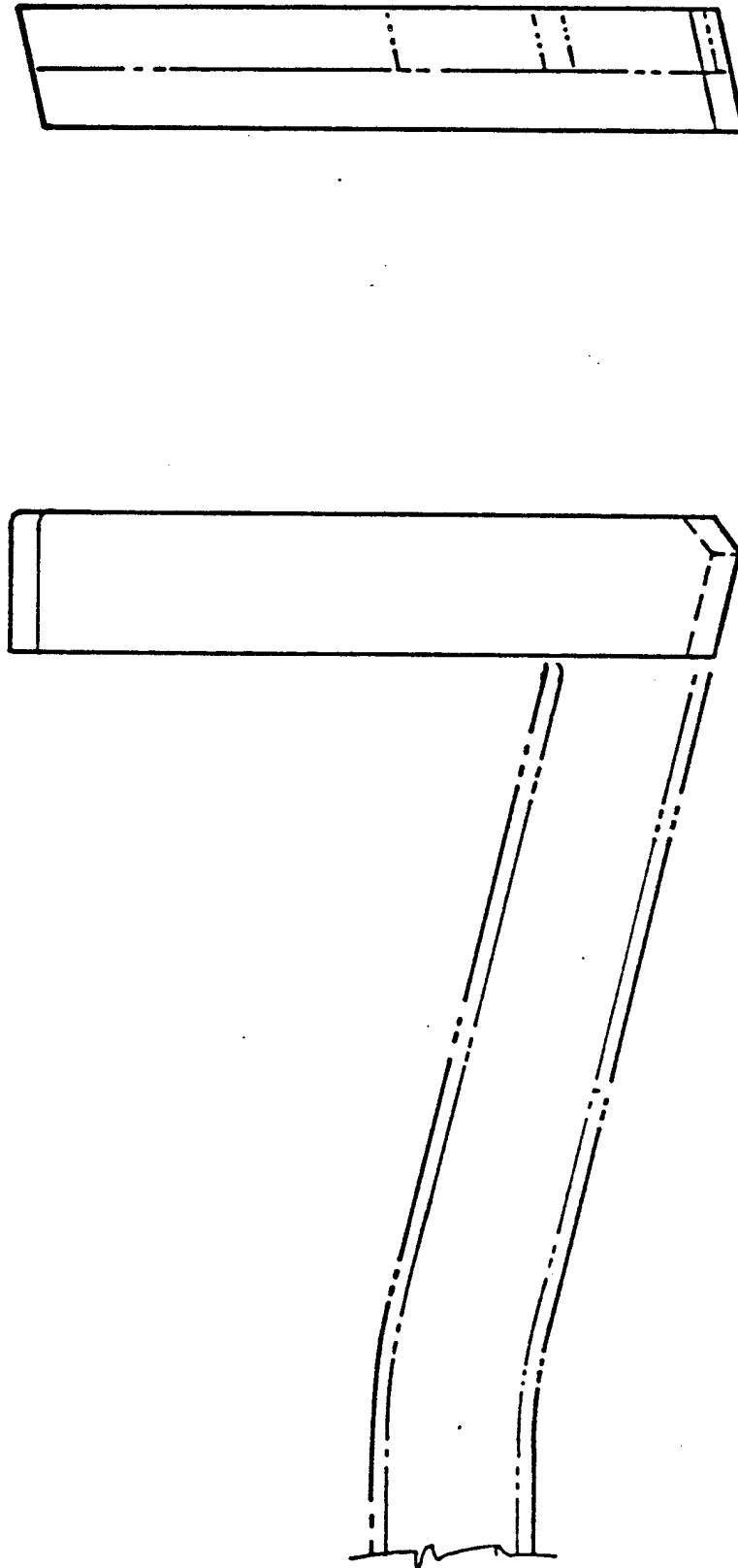

1 in.

Decrease In Weight Per Seat: 0.171 lb.

The remainder of the seat back closeout is replaced with a 6061 angle extrusion shown in Figure 2-5. Also seen in Figure 2-5 are the closeout for the seat bottom and the reinforcing angle between the seat bottom and the seat back. This angle has been simplified to a 7075-T6 extrusion as displayed in Figure 2-6. The closeout seen in Figure 2-5 was simplified into two (2) solid pieces shown in Figure 2-7.

Figure 2-8 displays shifting the lower attachment of the leg side support to a lower position. By doing this, the one piece bulkhead on the Baseline structure can be replaced by a top and bottom piece as shown in Figure 2-9. The lower piece ties into the lower attachment point of the leg side support. Each of the two (2) vertical members of the bulkhead of Figure 2-9 are replaced by two (2) angles which are bonded in place after assembly. The closeout member of the leg side support was, on the Baseline, a one piece machined fitting. It is to be replaced by a built-up structure consisting of two (2) castings and a channel extrusion which is to be subsequently slotted and bent as shown in Figure 2-10. The closeout for the bucket's bottom can also be simplified because of the previously discussed alteration of the leg side support. The details are shown in Figure 2-11 where the straight solid bar replaces the previously curved machined part.

The proposed redesigned joint between the seat back and the rail support is detailed in Figure 2-12. The Baseline design involves gun drilling and chem-milling of the fitting to reduce weight. The redesigned joint involves the

FIGURE 2-5

Weight Increase Resulting From Adding An  
Angle Reinforcement Between The Bucket Base  
And The Seat Back (Ref. Budd Dwg. J2545-101000)

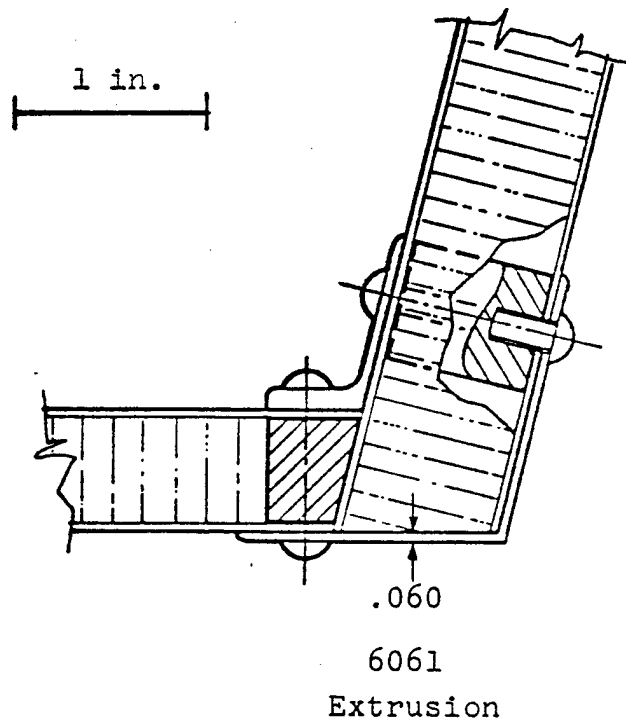

Increase In Weight Per Seat: 0.293 lb.

FIGURE 2-6

Weight Increase Resulting From Modifying The  
Seat Angle Bracket (Ref. Budd Dwg. D2379-0021)

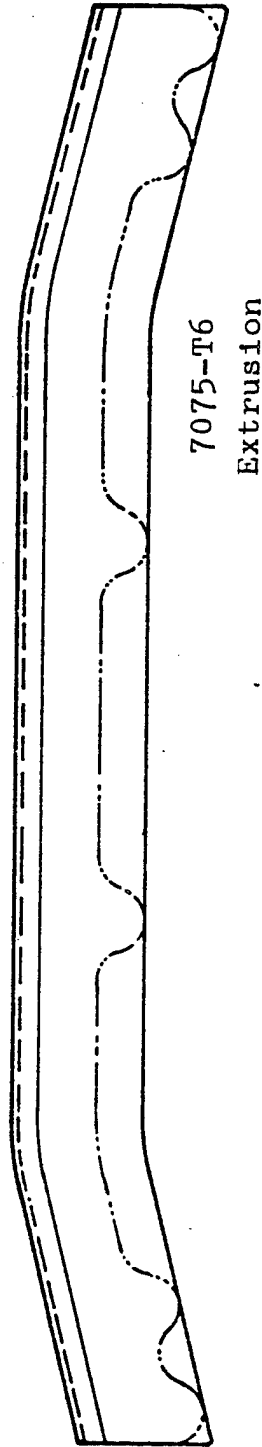

1 in.



Increase In Weight Per Seat: 0.038 lb.

FIGURE 2-7

Weight Increase Resulting From Modifying The  
Bucket's Rear Channel Fitting (Ref. Budd Dwg.  
D2379-0030 & 31)

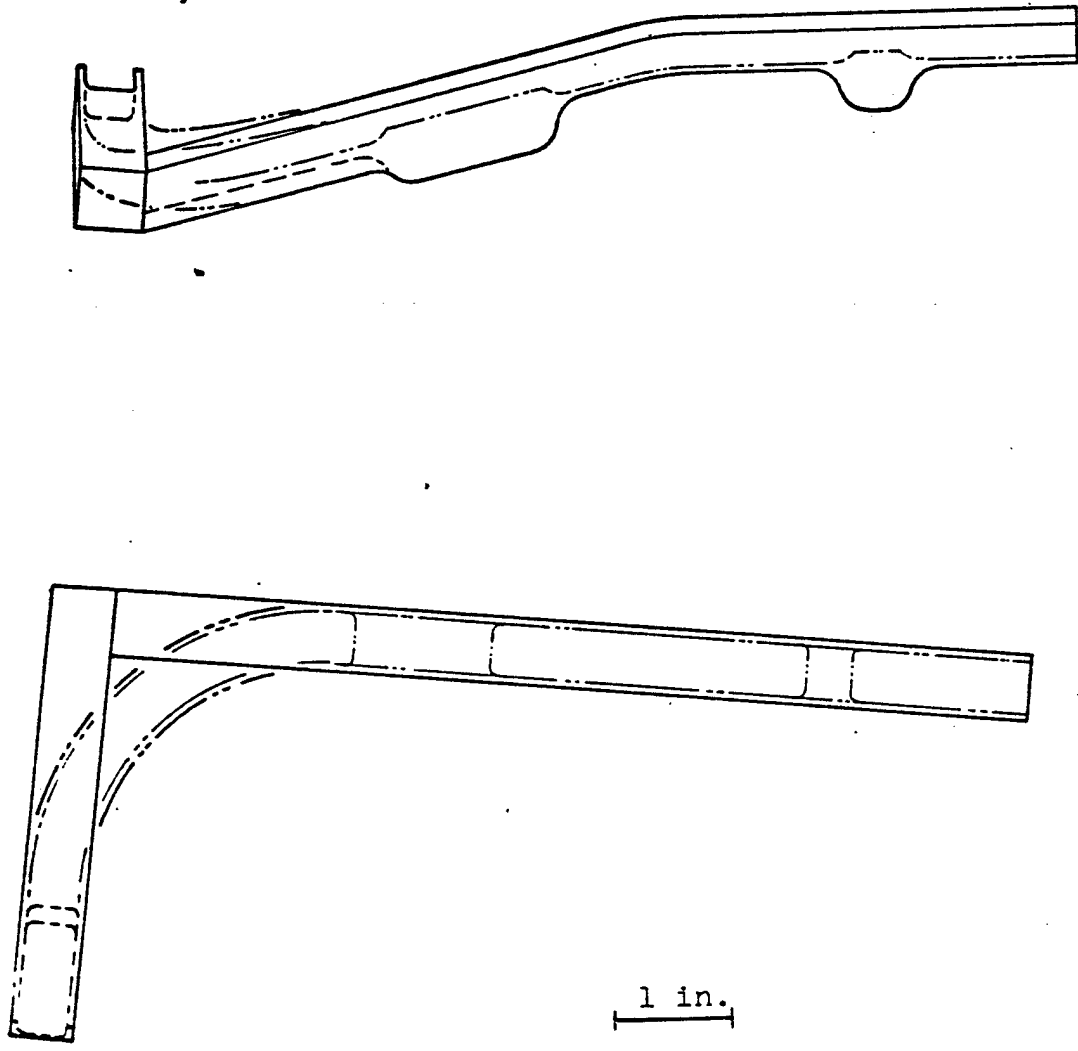

Increase In Weight Per Seat: 0.400 lb.

FIGURE 2-8

Weight Increase Resulting From Modifying The Leg  
Side Support (Ref. Budd Dwg. J2545-101000)

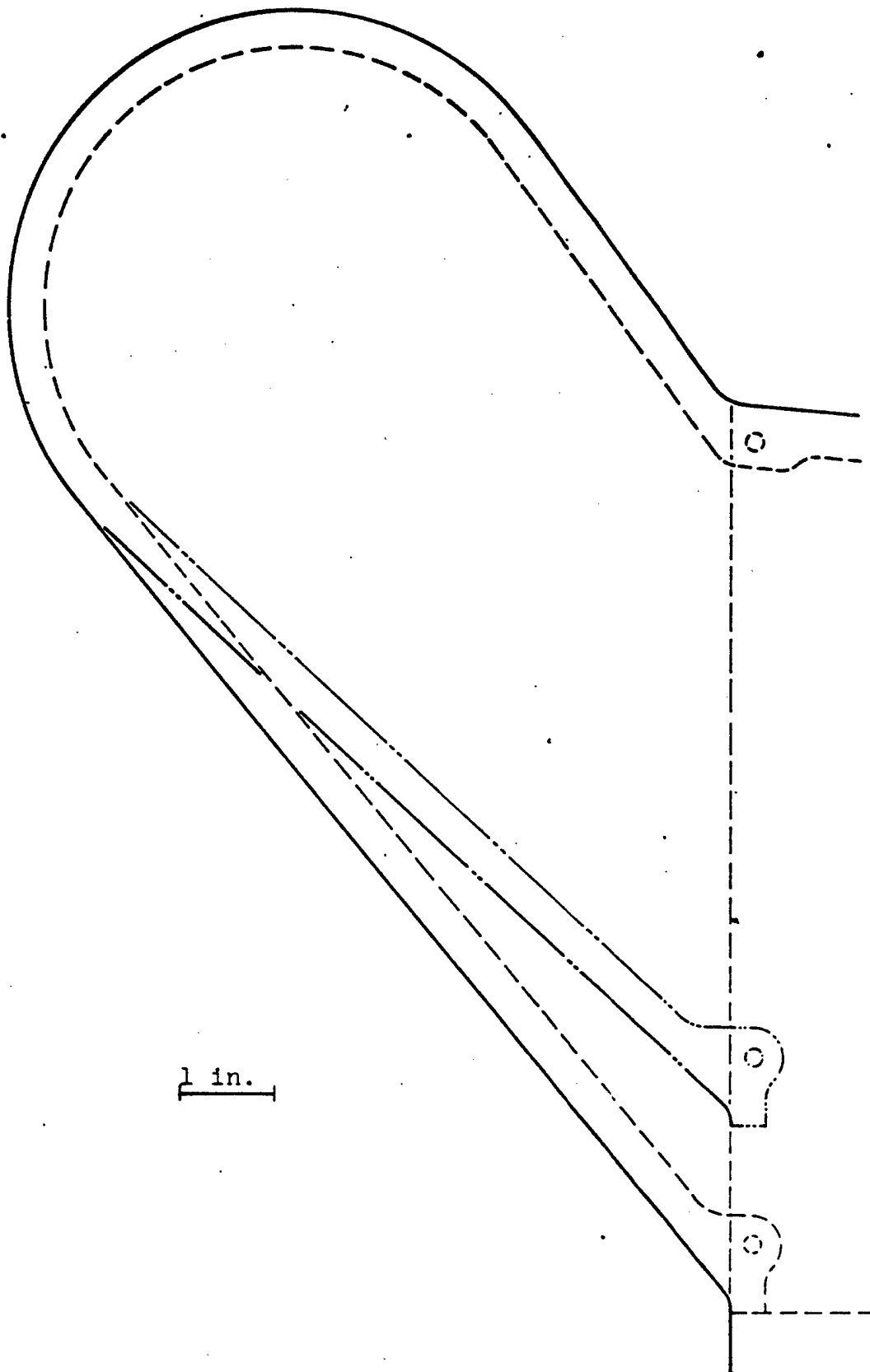

Increase In Weight Per Seat: 0.096 lb.

FIGURE 2-9

Weight Increase Resulting From  
Modifying The Bucket's Frame  
Bulkhead (Ref. Budd Dwg. D2379-0024)

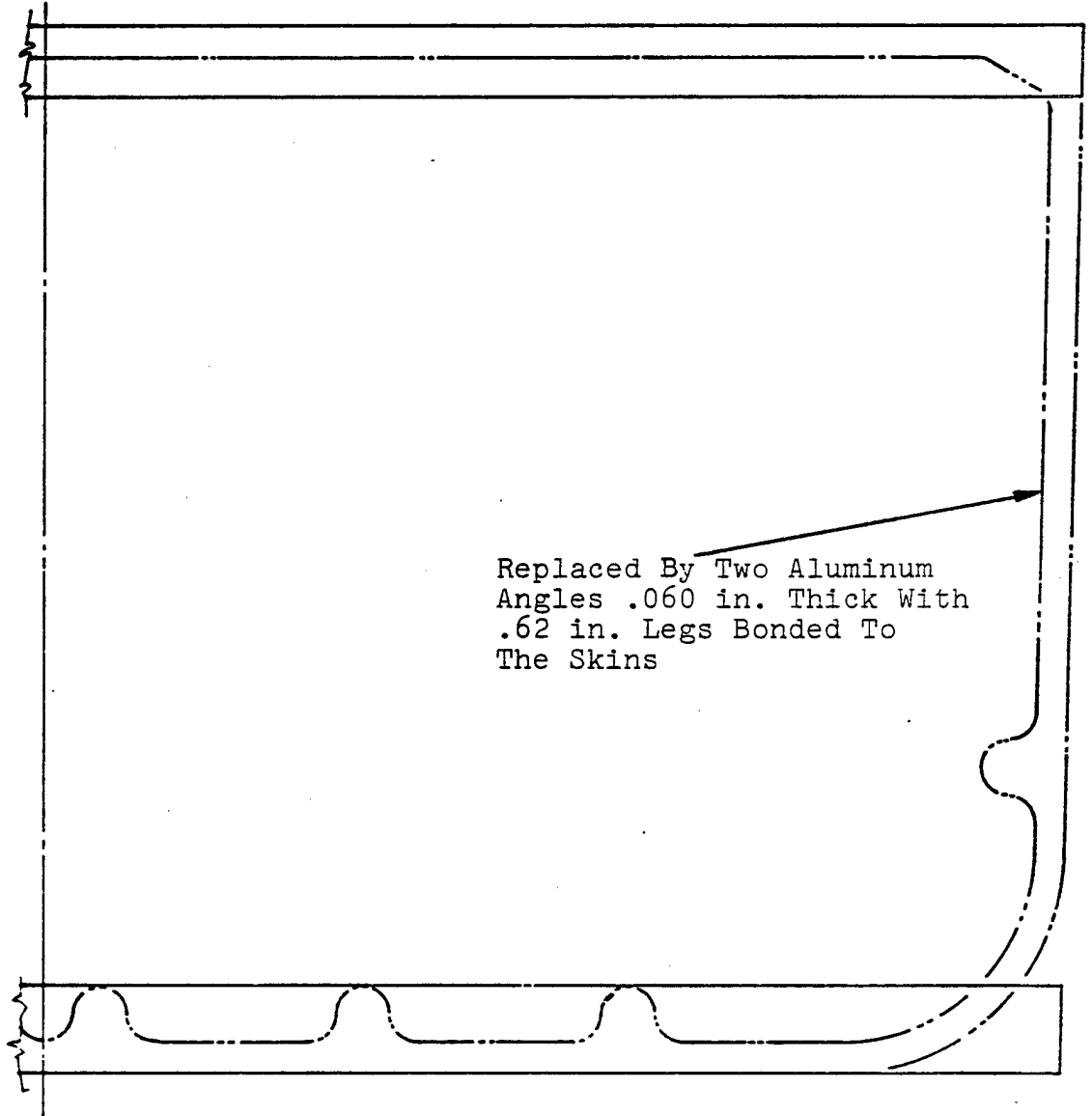

Increase in Weight Per Seat: 0.652 lb.

FIGURE 2-10

Weight Increase Resulting From Modifying The  
Bow Channel Fitting (Ref. Budd Dwg. D2379-0032)

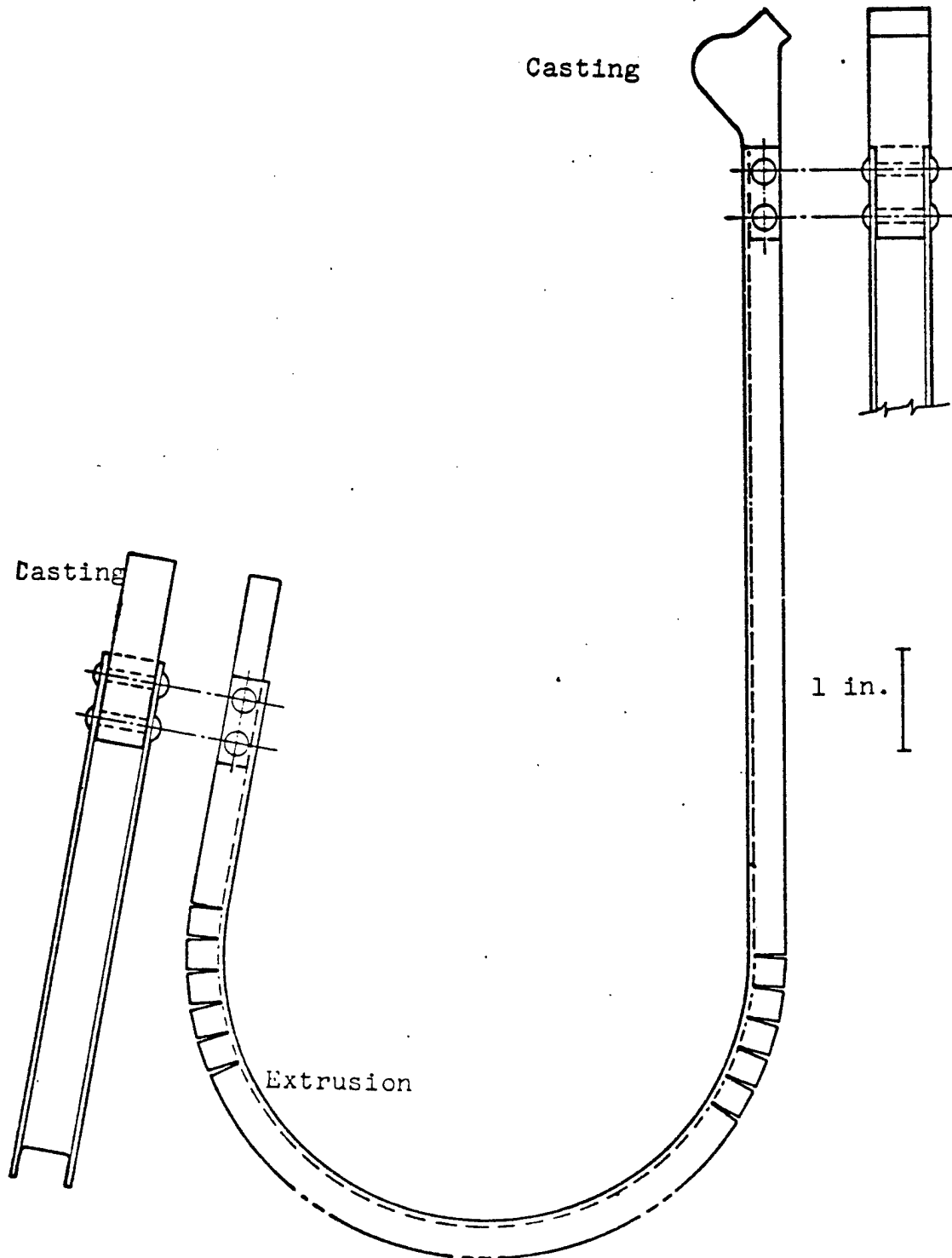

Increase In Weight Per Seat: 0.045 lb.

FIGURE 2-11

Weight Increase Resulting From Modifying The  
Bucket's Front Channel Fitting (Ref. Budd  
Dwg. C2379-0028 & 29)

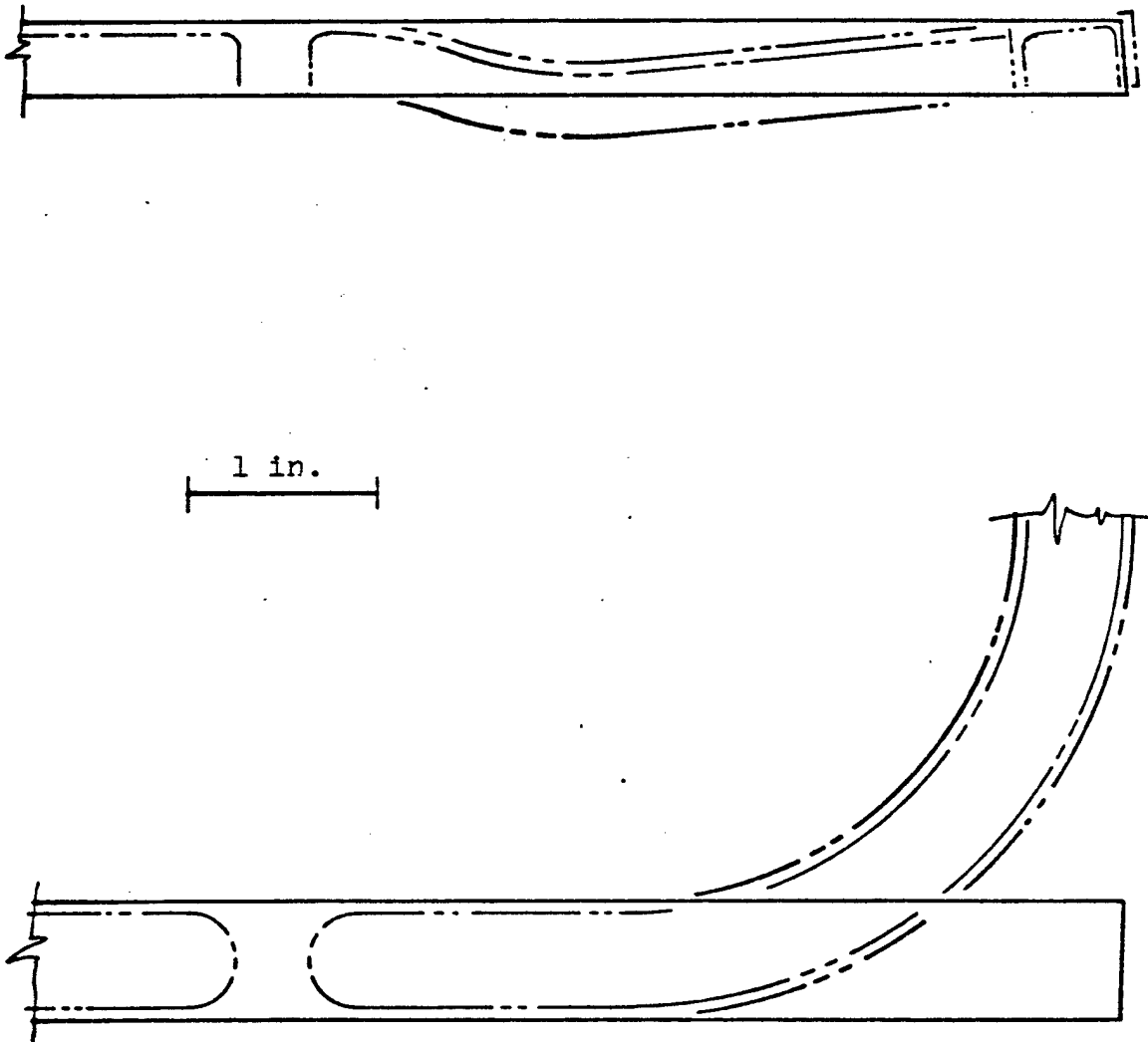

Increase In Weight Per Seat: 0.212 lb.

FIGURE 2-12

Weight Increase Resulting From Modifying The  
Corner Fitting (Ref. Budd Dwg. C2379-0013 & 14)

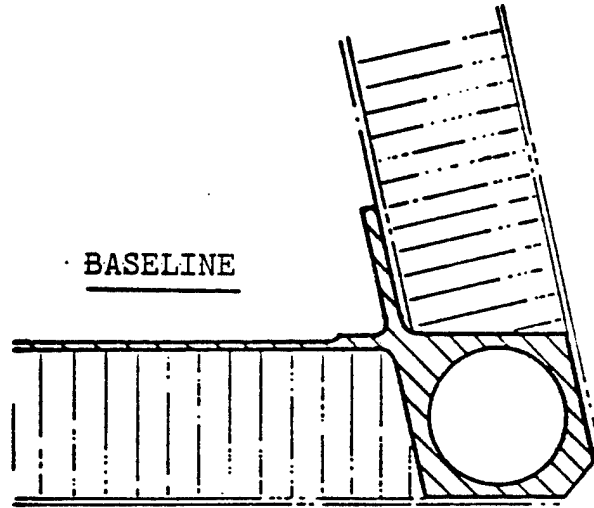

BASELINE

1 in.

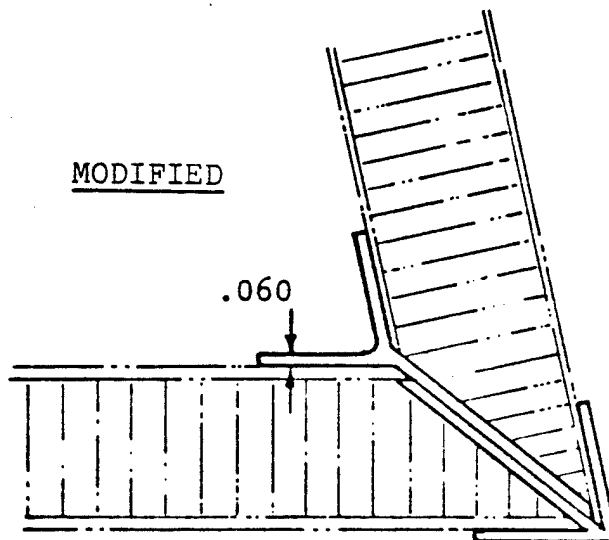

MODIFIED

.060

7075-T6  
Extrusions

Increase In Weight Per Seat: 0.541 lb.

use of two (2) extruded 7075-T6 shapes. The skin thicknesses are equal to the skin thicknesses of the Baseline where chem-milling was not performed on the fitting. The Baseline rails also involved chem-milling, which again is being eliminated in the redesign effort as shown in Figure 2-13. Here the rail will be a 7075-T6 extrusion which is then bonded and riveted to a plate whose thickness is equal to the nonchem-milled portion of the Baseline rail.

The main fitting of the bucket is shown in Figure 2-14. The redesign effort involves a built-up structure using a forging, an extrusion, and a casting which are bonded and riveted together. One final change involves the bucket's ring fitting which is to be a solid cross-section casting as shown in Figure 2-15.

In the previous discussions, wherever rivets are shown it should be interpreted that both rivets and bonding will be used together. The total weight increase per seat for those changes depicted in Figures 2-1 through 2-15, is 4.77 pounds. While it is felt that detailed layout drawings would indicate slight variations to what has been proposed, the weight increase obtained should still be considered a very reasonable estimate of a modified production MPES seat structure. In the redesign effort, no structural compromise has been required and it is anticipated that the modified seat would satisfactorily meet the same loading requirements as the baseline structure.

FIGURE 2-13

Weight Increase Resulting From Modifying The  
Rail (Ref. Budd Dwg. C2379-0011 & 12)

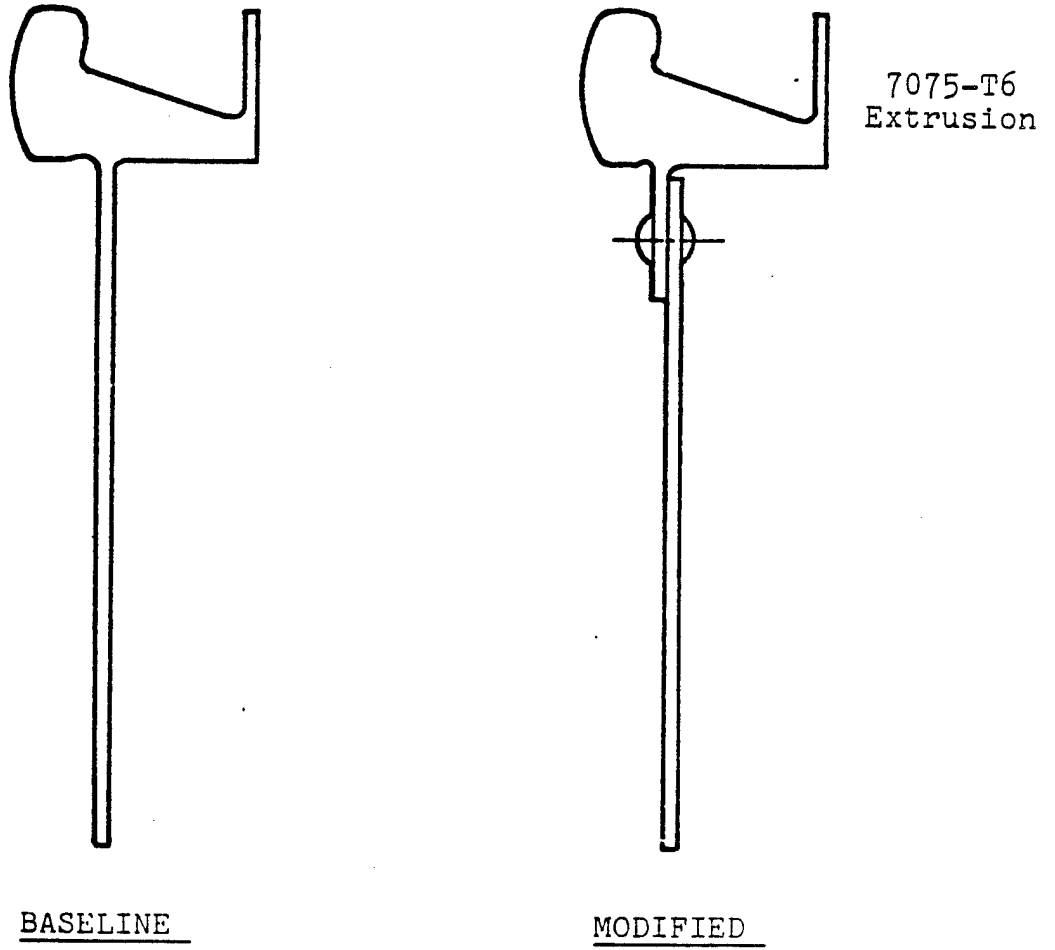

1 in.

Increase In Weight Per Seat: 0.921 lb.

FIGURE 2-14

Weight Increase Resulting From Modifying The Bucket's  
Spar Fitting (Ref. Budd Dwg. D2379-0022 & 23)

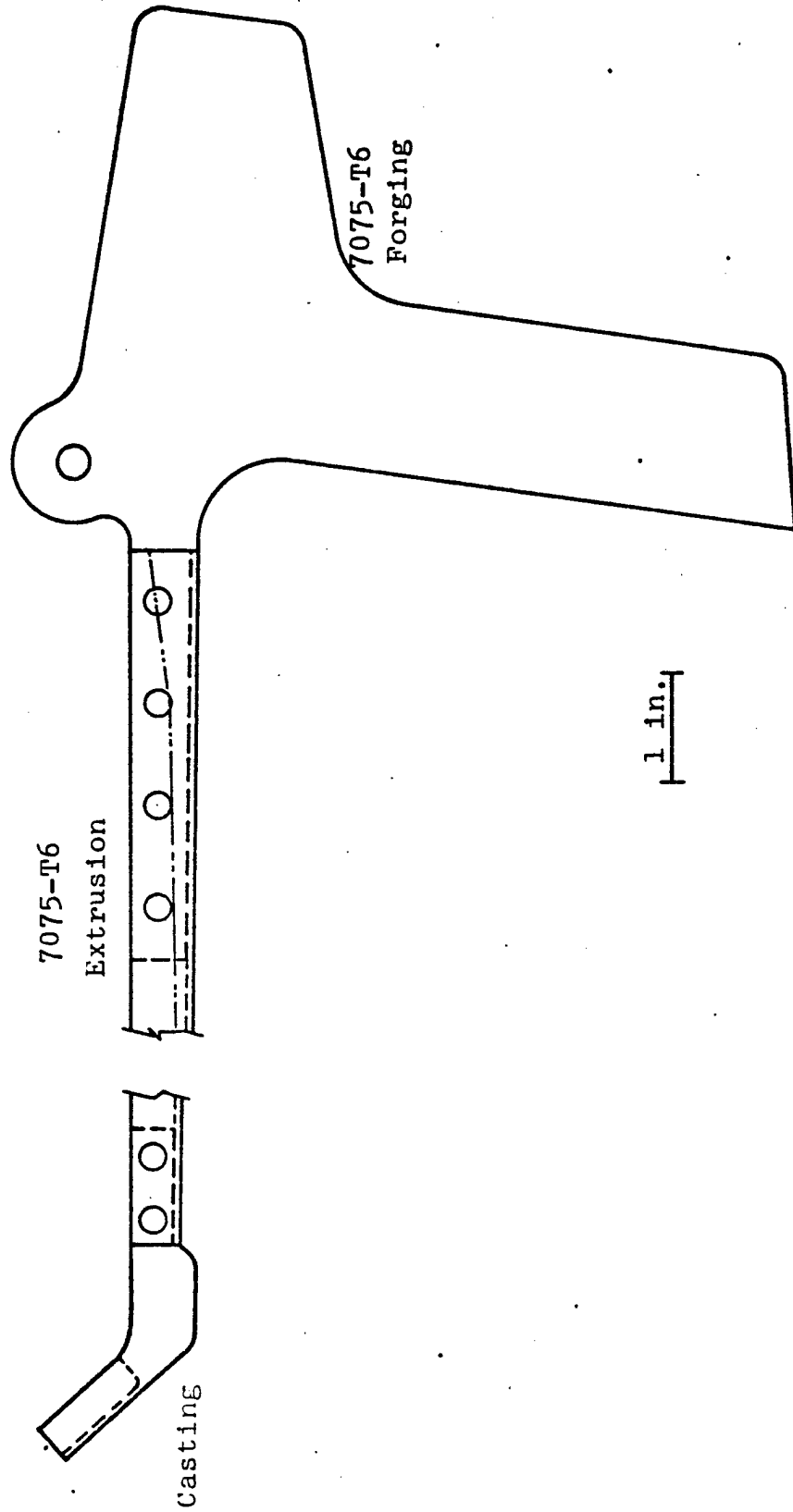

Increase In Weight Per Seat: 0.188 lbs.

FIGURE 2-15

Weight Increase Resulting From Modifying The Bucket  
Ring Fitting (Ref. Budd Dwg. J2545-101000)

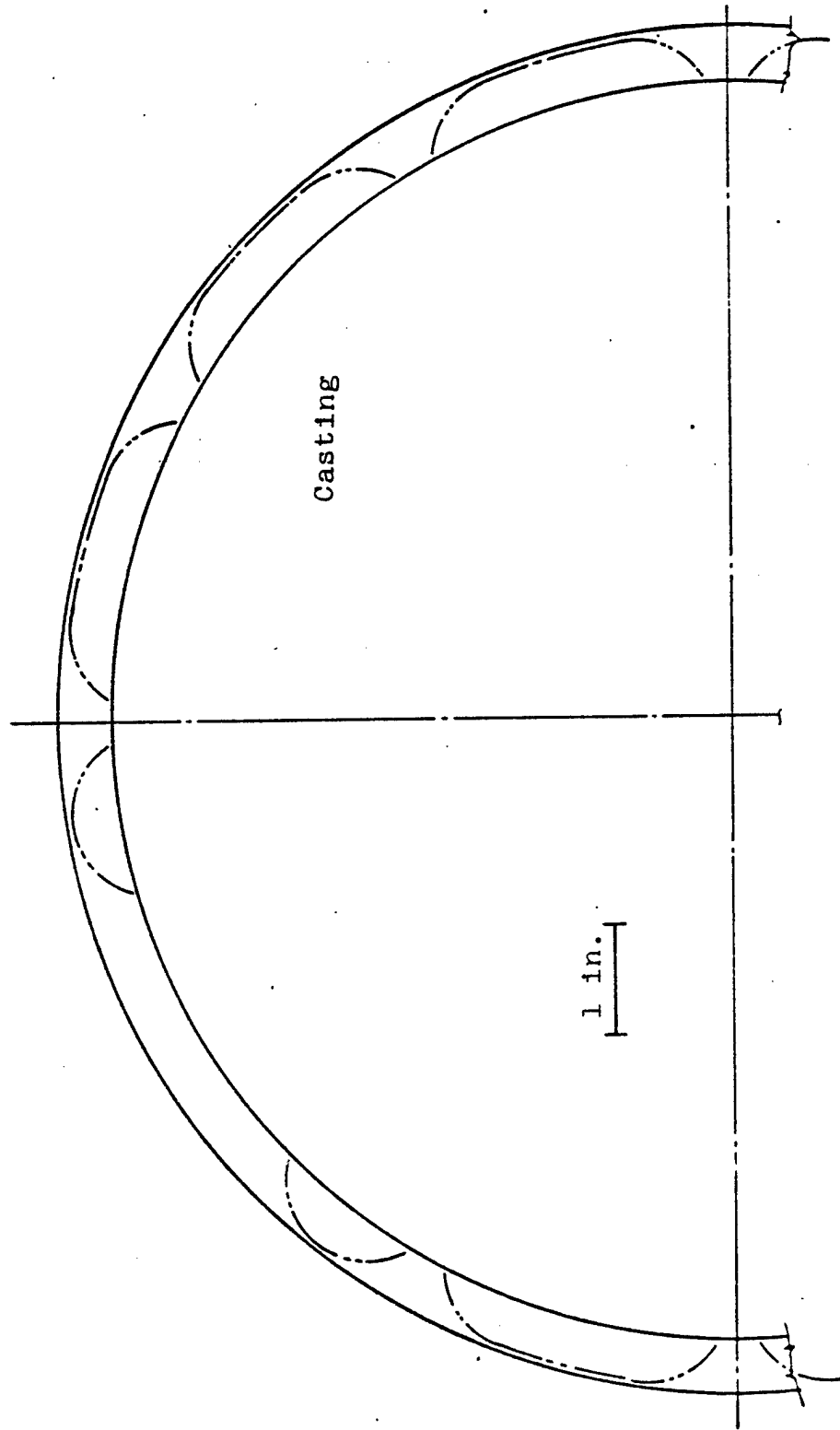

Increase In Weight Per Seat: 0.435 lb.

Two additional modifications were considered to those already presented in Figures 2-1 through 2-15. The first additional modification is shown in Figure 2-16 which replaces the built up leg side support with a casting. The casting is attached to the bucket the same way that the built up leg side support was. The side skins from the bucket, however, now only lap over the casting approximately 0.60 in. to insure a good shear tie. If the modification shown in Figure 2-16 is used in place of the previously described version, the weight increase of the ejection seat would go to 6.88 pounds up from 4.77 pounds for a weight delta of 2.11 pounds.

The second modification involves the one piece corner fitting shown in Figure 2-17 which would replace the two piece arrangement of Figure 2-12. The weight delta, over the 4.77 pounds, incurred by using the arrangement of Figure 2-17 is 2.39 pounds. If both Figures 2-16 and 2-17 were utilized then the total ejection seat weight increase would be 9.27 pounds. In the production cost evaluation of Section 4, the modifications shown in Figures 2-1 through 2-15 are priced out as one complete package. Then in addition the cost will be modified for Figure 2-16 and for Figure 2-17.

Weight Increase Resulting From Modifying  
The Leg Side Support (Ref. Budd Dwg. J2545-101000)

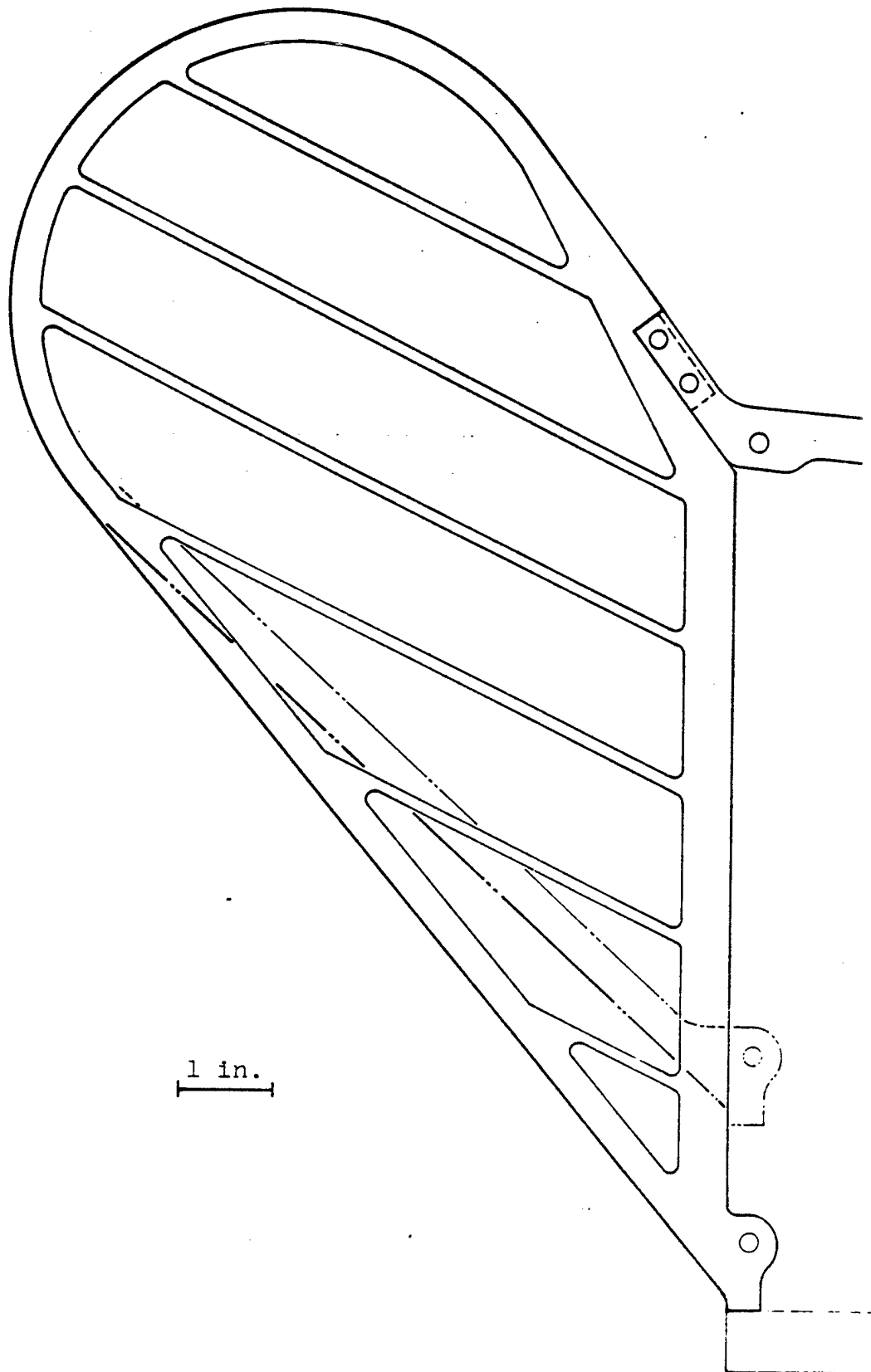

Increase in Weight Per Seat: 2.252 lb.

Weight Increase Resulting From Modifying  
The Corner Fitting (Ref. Budd Dwg. C2379-0013 & 14)

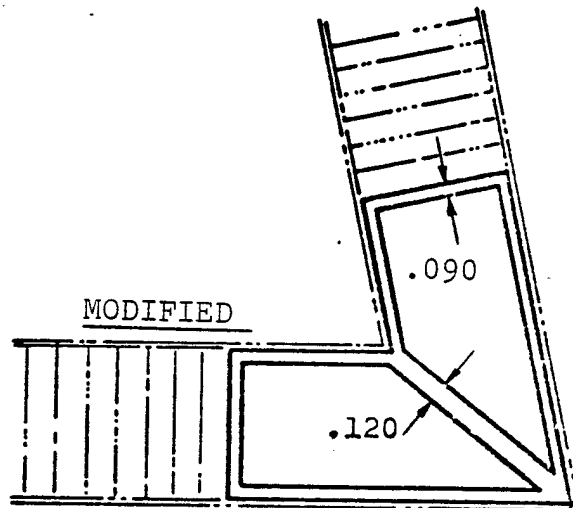
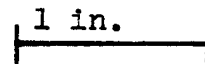
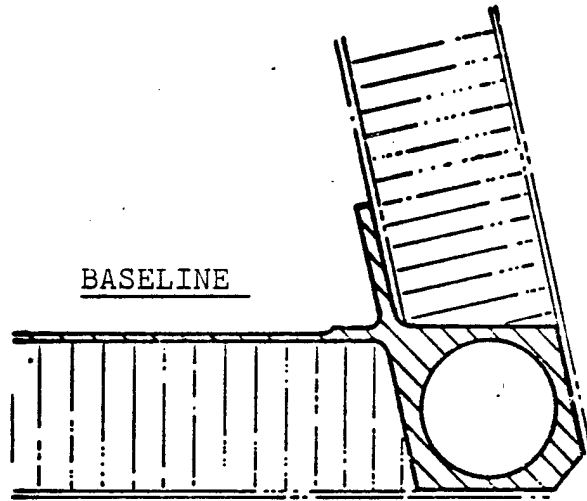

2024-T4  
EXTRUSION

Increase in Weight Per Seat: 2.932 lb.

### 3.0 Composite MPES Seat Structure

The unique features of composite materials, both as to their differences in fabrication and ability to easily tailor their structural properties when compared to aluminum, require a redesign of the MPES structure. In the aluminum designs, for example, the honeycomb core was chosen to provide the required shear strength at the critical section with the remaining sections being overdesigned. With the Composite design, however, every section becomes a critical section in order to minimize weight. The scope of the effort did not allow for an in-depth analysis and therefore the weight of the Composite design may not have been minimized. The resulting chosen Composite design utilizes the proven major load-carrying aluminum components from the metal designs with the sizing of the composite accomplished according to the following structural considerations:

- Match strength of baseline design
- In critical rail support and seatback structure, match stiffness of baseline seat to avoid additional drag on rails caused by excessive deformation
- Match the stiffness of the baseline bucket top and bottom to resist high normal ejection loading
- Match axial stiffness for the rest of the bucket construction

In addition, the following guidelines were followed:

- For those critical areas where bending loads exist, a sandwich, which is the most efficient construction, will be maintained.
- For those areas where no significant bending loads exist, a ribbed structure will be acceptable

### 3.1 Composite Material Properties

Prior to evaluating the potential composite designs, an understanding of the various composite materials is required. Table 3-1 lists the properties of several composite materials and 7075-T6 aluminum which is used extensively in the metal designs. The data for the composite systems represents woven balanced cloth. The cloth data is presented because of the availability of the data and because the composite will be used primarily in the areas of shear transfer (where a  $\pm 45^\circ$  layup is required) or in areas of a bi-directional loading (where a 0/90 layup will be used). For actual construction, non-woven angle-ply material (i.e.,  $\pm \theta$  fiber direction) can be obtained from the fiber manufacturer or prepregger and the material will be used in this form.

All of the composite systems of Table 3-1 have specific tensile strengths which equal or exceed that of the aluminum. The compressive strength magnitudes for the graphites are basically the same as for tension while there is a modest reduction for the E and S glass composites. The Kevlar 49 composite has relatively poor compressive strength, approximately 30 percent of its tensile strength.

Comparing the specific tensile modulus from Table 3-1, only the graphite exceeds the aluminum value, with Kevlar 49 fairly close. From the standpoint of impact resistance and energy absorption, the Kevlar 49 is much better than the

TABLE 3-1

MATERIAL ALLOWABLES

<u>Material System</u>	<u>Density Lbs/in<sup>3</sup></u>	<u>Allowable Strength PSI</u> (1)	<u>Specific Strength 10<sup>6</sup> In</u>	<u>Tensile Modulus 10<sup>6</sup> PSI</u>	<u>Specific Modulus 10<sup>6</sup> In</u>
7075-T6 Aluminum	.100	70,000	0.70	10.0	100
Type A Graphite (2)	.055	71,000	1.29	11.0	200
Kevlar 49 (2)	.050	70,000	1.40	4.5	90
S Glass (2)	.065	60,000	0.92	3.7	57
E Glass (2)	.064	44,000	0.69	2.8	44
Boron	Too expensive and difficult to work with				
HMC (Chopped Glass System)	.064	25,000	.039	2.0	31

(1) Aluminum and HMC: yield strength (bottom of scatter)

Composites: mean ultimate strength - 3 x standard deviation.

(2) Values are for a woven, balanced (i.e., equal strength in 0° and 90° directions) cloth.

relatively brittle graphite. However, the structural properties of Kevlar, especially the compressive strength, are on the whole not as good as the graphite. In addition, the design chosen places the higher load reactions in the aluminum frame without the need to go through a highly loaded aluminum/composite joint. This should prove beneficial in an impact environment.

The conclusion is that the graphite system appears to be the best choice to match the structural characteristics of the aluminum seat. While Table 3-1 presents material data for Type A graphite only, there are actually two other types of graphite, namely the High Modulus (HMS) and High Strength (HTS) graphites. The HMS fiber was not considered because it has a much lower ultimate tensile and compressive strength, than the Type A graphite, along with its increased modulus. The HTS fiber has slightly higher strength and even a higher modulus than the Type A graphite, but its cost is considerably greater. In any detailed design, all three graphite types would be candidates and the different fibers may be used at different locations on the seat while utilizing the same basic resin system. For this study, however, the use of the Type A graphite fiber was considered exclusively.

### 3.2 Design Concepts

A number of concepts were considered in designing with composite materials. The most promising ones are presented in Figures 3-1 through 3-3, where the significant advantages and disadvantages are noted. In Figure 3-1 is presented a

FIGURE 3-1

CONCEPTS FOR COMPOSITE EJECTION SEAT

Aluminum and/or Nomex Core With Continuous  
Fiber Composite Skins (Cocure Fabrication)

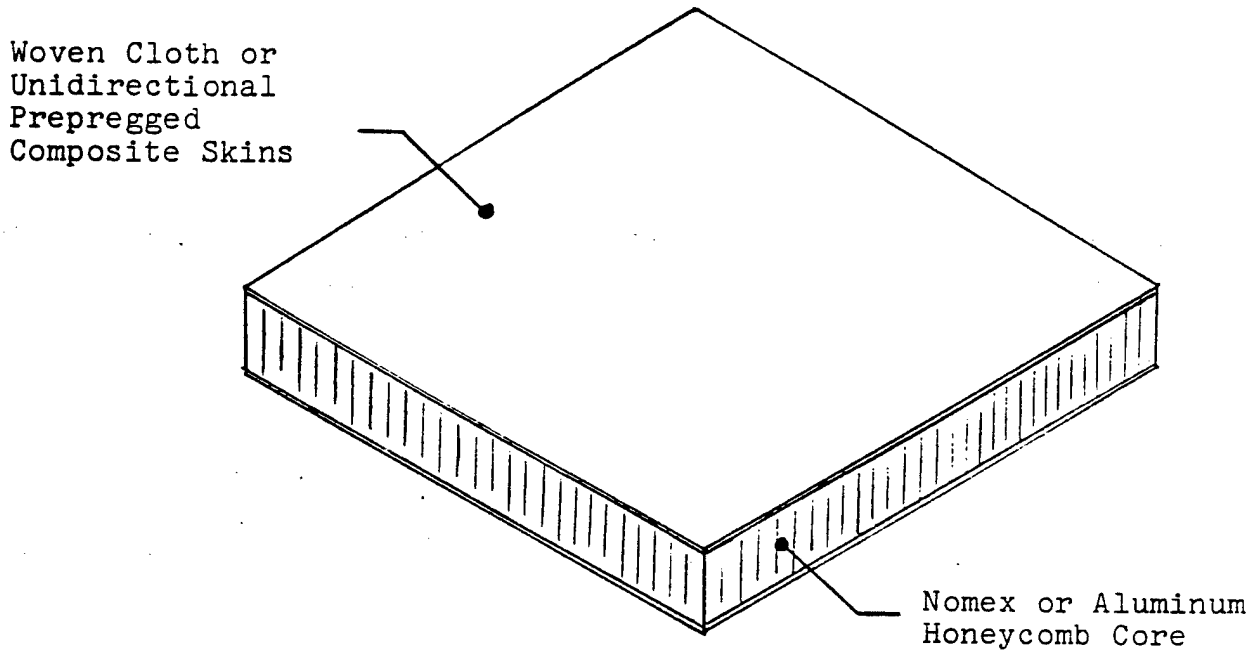

Advantages

- Lightest Design
- Can Easily Change Thickness of Skin Locally

Disadvantages

- No Significant Cost Savings
- Requires Autoclave Cure
- May Require Protection Against Galvanic Corrosion
- Local Reinforcements Needed for Bolting and Riveting

FIGURE 3-2

CONCEPTS FOR COMPOSITE EJECTION SEAT

Reservoir Molding

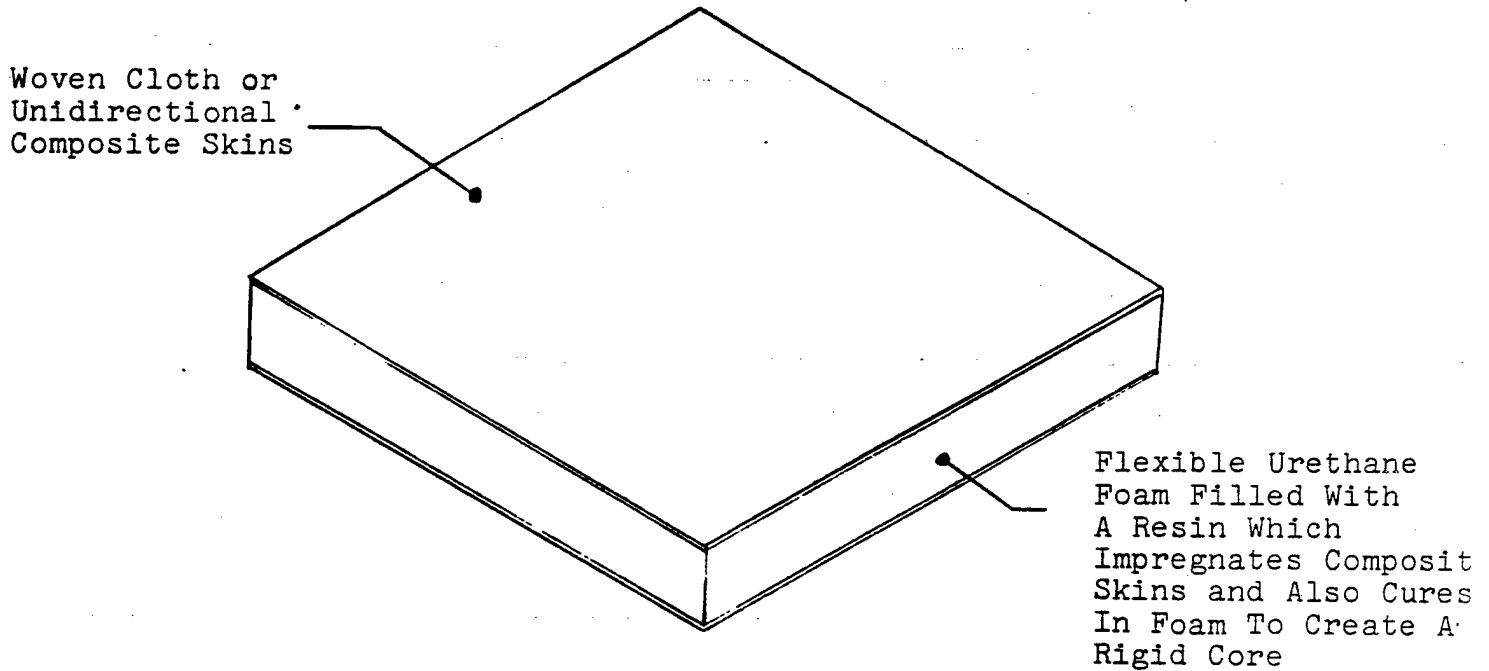

Advantages

- No Machining of Core Required
- Works With Dry Fabric Skins
- Can Easily Change Thickness of Skin Locally

Disadvantages

- Difficult to Locate Local Reinforcements For Use In Bolting and Riveting
- High Core Density Required to Carry Shear Loads
- Restricted to a 250° F Curing Resin because of Foam Degradation

FIGURE 3-3

CONCEPTS FOR COMPOSITE EJECTION SEAT

Compression Mold 2 Halves and Bond Together

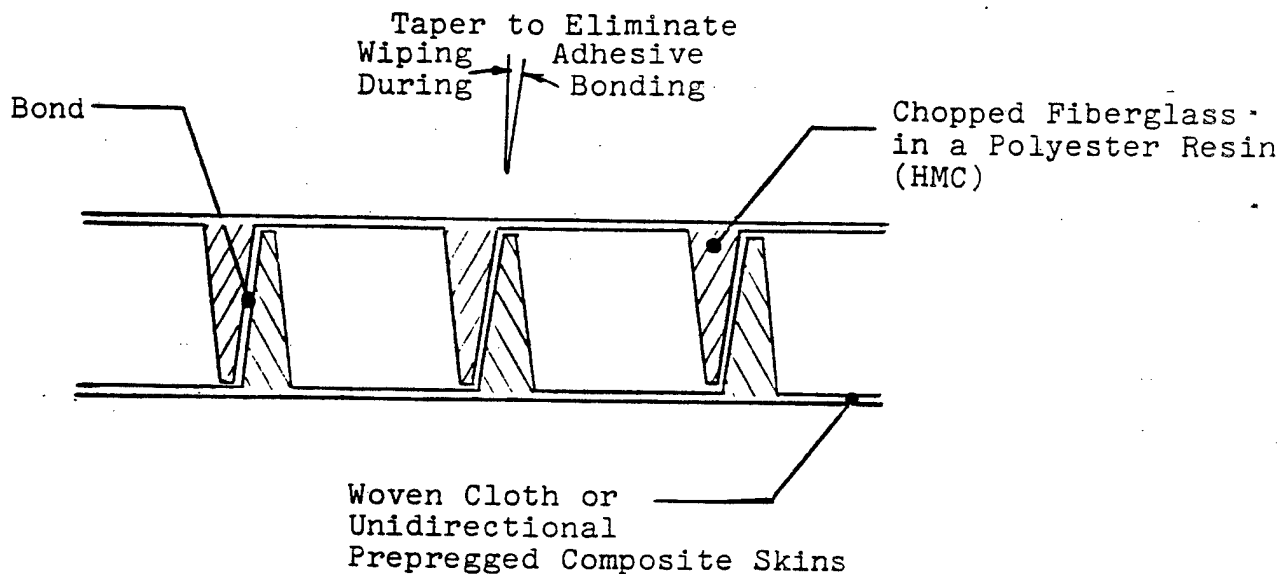

Advantages

- Potentially Low Cost
- Can Locally Change Rib Spacing and Size to Match Loading
- Can Locally Provide Reinforcements For Use in Bolting and Riveting
- Uses Relatively Low Cost Tooling
- Can Easily Change Thickness of Skin Locally

Disadvantages

- Heavier Than Baseline

sandwich concept where the aluminum skins are replaced by graphite. This approach produced the lightest design of the ones considered but it afforded no significant cost savings. In Figure 3-2, the honeycomb core of Figure 3-1 has been replaced by an open cell flexible foam which has been saturated with resin. The assembly is placed in a closed mold and pressure and heat applied. The pressure forces the excess resin out of the foam to impregnate the (woven) skins. Upon curing, the remaining resin left in the foam causes it to become rigid. Unfortunately, if the shear strength of the aluminum honeycomb core is required, the foam density needed to match this strength becomes much too high.

### 3.3 Selected Composite Design Concept

The concept presented in Figure 3-3 appears to be the one which has the most potential for reducing the cost of the ejection seat. It utilizes a graphite fiber outer skin which is simultaneously cured with, and bonded to, the ribs which are made from the HMC chopped glass system. The resin used will be a relatively quick curing polyester system and matched metal molds will be used to provide the heat, pressure, and component shape. From Reference 1, the interlaminar shear strength for the chopped fiber systems is approximately 4700 psi. Using this value it was possible to size the ribs shown in Figure 3-3 such that the rib shear strength would be equivalent to the aluminum honeycomb core.

Two separate compression moldings would be designed so that they could be subsequently joined by bonding the HMC ribs together using a quick cure gap filling adhesive, thus forming a sandwich structure. The ribs shown in Figure 3-3 are tapered for two reasons. First, the maximum shear strength is not required along the entire height of the rib and so to save weight the thickness at the tip is reduced to the minimum which can be commercially molded. Second, by tapering the rib, the adhesive will not be wiped away when the two halves are bonded together. When the structure is not a sandwich, then the rib will be a constant thickness except for the draft required to remove the part from the mold.

Figures 3-4 and 3-5 give the proposed Composite version of the MPES ejection seat. A total of eleven different moldings are required to form the basic structure. The eleven moldings are:

- Side Structure - including rail support, bucket side, and knee support - Right and Left required.
- Rail Support - bonds to the side structure to form a sandwich structure - Right and Left required.
- Seat Back - consists of a Front and Rear molding which are bonded together to form a sandwich structure.
- Bucket Lid - consists of an Upper and Lower molding which are bonded together to form a sandwich structure.
- Bucket Bottom - consists of an Upper and Lower molding which are bonded together to form a sandwich structure.
- Bucket Front - a single molding.

In addition to the basic eleven moldings there are 4 main aluminum structural members, 3 of which are extrusions and





one is a relatively simple machining.

As noted previously the HMC ribs were sized to match the shear strength of the honeycomb core in the critical areas. Outside of these areas, the ribs were allowed to reduce in thickness as the load decreased. In order to assemble the two halves of the sandwich, the ribs must nest. Figure 3-6 provides the type of nesting which is envisioned.

### 3.4 Manufacturing Process

The following is a brief description of the anticipated production sequence along with an overview of the required equipment:

- For large quantity production, up to a maximum range of 2000 seats, zinc or aluminum molds can be used.
- The minimum taper on the side walls will be 1 to 3°.
- The mold will be provided with a means of heating to 400° F.
- The total mold (both halves) is estimated to be 10 inches thick with a 3 inch boundary around the part perimeter for adequate high temperature uniformity.
- The mold should be mounted in a hydraulic press whose tonnage capability is equal to 1000 psi of plan view of the molded part.
- The graphite prepreg is trimmed to fit the mold using a steel rule die and the various plies are then stacked.

FIGURE 3-6

Possible Nesting Design For  
Bonding Together Two Halves

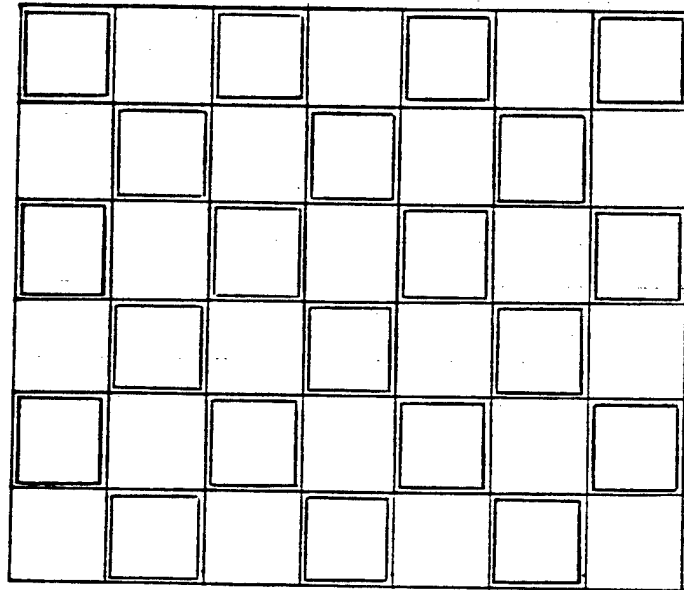

- The HMC material is cut to match the pattern of the ribs using a steel rule die.
- The die cut HMC piece can be placed on the graphite prepreg for support and the complete charge is then transferred to the mold.
- The mold temperature should be maintained at 300° F and the charge placed with the HMC material facing up.
- The mold is closed and the pressure is maintained during the complete cure. The cure time generally is one minute for each 0.125 in. of maximum thickness.
- During the cure cycle, the next charge can be prepared.
- After the cure time, the mold is opened and the part removed.
- The excess flash is trimmed from the molded part.

After the basic eleven parts have been molded then those areas to be bonded will be either primed or abraded and solvent wiped and then bonded together using an adhesive, such as Goodyear's Pliogrip adhesive system. This system has a quick room temperature cure (although an exothermic reaction is encountered) using light pressure. This adhesive is a flexible one and displays a relatively stable bond strength over a wide range of bond line thicknesses.

### 3.5 Estimated Weight of Composite MPES Seat

The Composite MPES seat which is detailed in Figures 3-4 and 3-5 and described in the previous sections is estimated to weigh 41.0 pounds. The weight consists of 9.3 pounds of graphite prepreg, 16.5 pounds of HMC chopped glass/polyester and 1.6 pounds of adhesive. The remaining 13.6 pounds are in the aluminum extrusions and machinings and miscellaneous hardware.

Some weight reduction is anticipated after a detailed stress analysis of the proposed Composite seat is completed. It will be possible to eliminate some of the 41.0 pound weight by reducing some of the conservative assumptions used in arriving at the total weight. Even if the 41.0 pounds is a realistic number then another possibility exists for reducing the weight. If the chopped glass in the HMC material is replaced by chopped graphite fiber, an additional savings of 2.3 pounds can be achieved for a composite seat weight of 38.7 pounds. While HMC using graphite fibers is not presently in commercial production, there is no hesitancy on the material suppliers part to indicate that such a system is possible. Another potential benefit could be obtained by using chopped graphite fibers in the HMC, which is the possibility of a higher shear strength. The standard HMC has an interlaminar shear strength of approximately 4700 psi which was used in the design of the ribs. Very limited testing indicates that HMC with graphite fibers could have an interlaminar shear strength of 5200 psi. If this higher strength is possible, then an additional 1.2 pounds of material could be saved resulting in a final composite MPES seat design weighing 37.5 pounds.

### 3.6 Potential for Success of Composite MPES Seat

The proposed composite seat fabrication concept represents a significant departure from most aerospace structures and as such would require some development effort. The point of uniqueness entails the mixing of two different composite systems, one being HMC which is expected to flow readily under pressure to fill the rib cavities in the mold. The other material,

the continuous fiber graphite prepreg, should not be allowed to flow in order to maintain proper fiber orientation and to be free of fiber wrinkles which would reduce its strength. Some development work is necessary to establish the techniques for satisfying these requirements. Prior to suggesting the chosen approach some trial runs were made using an aluminum mold containing a single rib. Figure 3-7 presents photographs of the results of these trial runs. It appears that the previously noted objectives were obtained for the two different composite systems used.

Upon removing the cured part from the mold, there will be some thermal distortion as the part cures to room temperature. This distortion should be reduced if the chopped graphite fiber is used in place of the glass in the HMC material. In any event, it is anticipated that the thermal distortion will be small and that when the molded parts are bonded to the aluminum fittings or to each other to form sandwich constructions, the distortion can be eliminated. The residual stresses resulting from flattening the molded part should not be critical. Another alternative is to machine the mold to account for the resulting thermal distortion such that the molded part will be relatively flat after cooling to room temperature.

The two basic load carrying structural materials used in the composite seat, namely aluminum and graphite, have extreme differences in their coefficients of thermal expansion. For aluminum the coefficient of thermal expansion,  $\alpha$ , is  $13 \times 10^{-6}$  in/in/°F while for a [0/90] graphite/epoxy layup the 0 or 90°

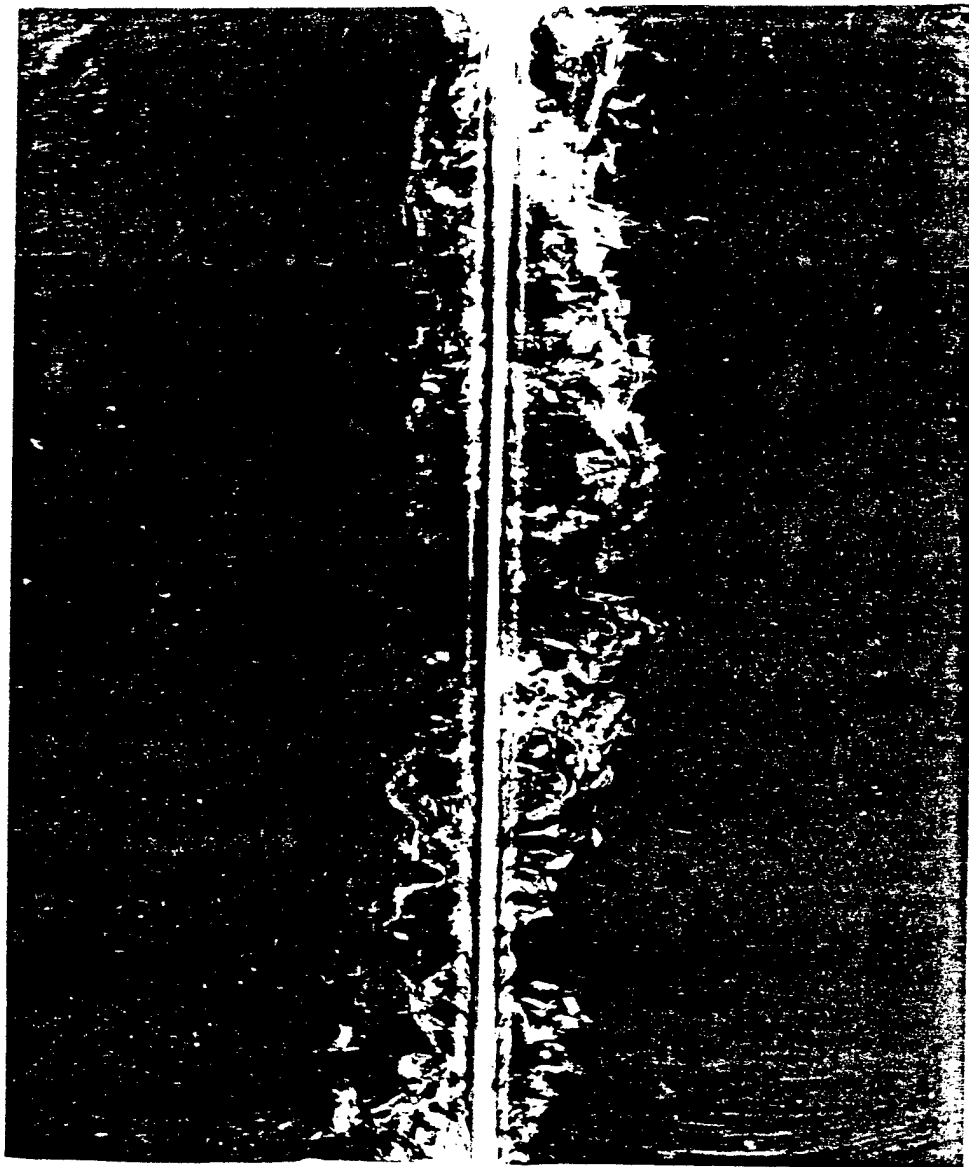

FIGURE 3-7

RESULTS OF TRIAL RUN COMPRESSION MOLDING USING HMC  
RIBS AND CONTINUOUS GRAPHITE FIBER/POLYESTER RESIN

value is  $1.7 \times 10^{-6}$  in/in/°F. The difference can cause thermal stresses in the room temperature cured bondline joining the two materials. The proposed composite seat design involves a number of such aluminum to graphite bonds which must be analyzed. To obtain a rough estimate of the resulting thermal stresses consider a bimetallic strip which is prevented from rotating and which has an aluminum thickness of .060 or .090 inches and a [0/90] graphite thickness of .036 or .060 inches. The worst condition for each of the aluminum, graphite and bond does not occur for the same thickness geometry. The maximum aluminum stress for a 130° F temperature change from room temperature is 7080 psi. For the same temperature change, the maximum graphite stress is 9970 psi and the largest average shear stress in the adhesive is 840 psi.

The adhesive mentioned as a possibility, Goodyear's Pliogrip, is a relatively flexible one. This is an advantage for tolerating thermally induced deformations without failing. The stress values indicated do not represent a potential problem by themselves. In reviewing the load history on the seat it appears that the mechanical load and the thermal loads do not act at the same time. When the pilot ejects, the maximum forces are applied to the seat. The seat, however, has been in a temperature controlled environment prior to ejection. Due to the short duration of the ejection, the seat does not have sufficient time to develop the thermal loads. It is only during the relatively unloaded freefall condition that thermal stresses begin to develop. Hence, it should be satisfactory to perform a thermal stress analysis

independent of the mechanical loads stress analysis.

No formal stress analysis has been performed on the proposed composite ejection seat. As such the dimensions and weights can only be considered to be estimates. An attempt, however, was made to develop the composite seat using concepts which proved satisfactory with the aluminum seats. The main reactions from the ejection thrust are taken by the upper and lower aluminum fittings of the bucket. The [± 45] graphite skin between these two fittings provide the shear transfer capability while the ribs prevent compressive instability.

The aluminum rail from the baseline aluminum seat is retained. In addition a major structural fitting at the junction of the seat back and rail support is made from aluminum. A slight departure exists where the upper and lower aluminum fittings of the bucket extend through the just mentioned aluminum corner extrusion back to the rail. All four aluminum pieces are subsequently riveted together to form the backbone of the seat. In addition, because the side of the seat is molded as one piece, an excellent shear tie is provided by the graphite between the rail support and the bucket. The rest of the structure is very similar to the aluminum design except the previously discussed compression molded parts replace the aluminum honeycomb core and aluminum skins.

In summary, it is thought that by basing the design on the existing successful aluminum seat that the composite version can be designed to be structurally equivalent. Some development

work is required for the compression moldings but based on the trial runs performed it is expected that the proposed approach will be producible as described previously.

### 3.7 Environmental Effects

Most of the published work involving environmental effects utilize epoxy resin systems. The results presented here will be for such resins even though polyesters are being considered for actual production fabrication. If polyesters prove to be unsatisfactory then the slightly longer curing "snap cure" epoxy systems may be an acceptable alternative. The results to be presented on coated systems should pertain somewhat to the coated polyesters although actual testing is required.

The first environmental condition considered is high and low temperatures. As mentioned previously, the ejection seat is nearly room temperature at the time of ejection which is the time of maximum loads. At other times the seat is minimally loaded and temperature extremes are not expected to create much of a problem since the graphite/epoxy system can operate from approximately  $-65^{\circ}$  F to  $250^{\circ}$  F. Due to the lower loadings at the temperature extremes, the changes in material properties should not cause any significant problem. The effect of a soak at the temperature extremes and the effect of cycling between these extremes should prove to be of no problem. This is principally because the normal temperature extremes encountered are not that severe and would probably occur during ground tie-down.

Humidity effects are next considered. For unprotected graphite/epoxy laminates, Reference 2 provides the information presented in Figures 3-8 through 3-10. In these figures the baseline represents specimen tests where no weathering has taken place. The thermo-humidity cycle consists of the basic 98 ( $\pm$  2)% relative humidity plus 1-1/2 hour exposure at  $-65^{\circ}$  F each day followed by 1/2 hour at  $250^{\circ}$  F. The accelerated weathering used a weatherometer. As can be seen in Figures 3-8 through 3-10, the graphite system tested shows very little degradation in the mechanical properties tested. One might argue that the tests may show a greater degradation if the exposure had been performed with the specimen under load. However, when the seat is subjected to a moisture condition, it is relatively unloaded and the test results presented are therefore applicable. Two further comments are required: where actual test data is presented, the data represents the response of a particular graphite/epoxy system and it is not necessarily typical of all graphite composite systems. Secondly, effects of moisture, where detrimental, can be minimized with the application of a suitable surface protection coating.

Moisture may reduce the graphite composite bond strengths through the potential galvanic corrosion problem when such materials are in contact with the aluminum portions of the seat structure. In Reference 3 the problem was investigated using two environments, ASTM 5% salt spray and synthetic seawater plus sulphur dioxide spray. The effect on the adhesive bond between the graphite laminate and the aluminum honeycomb

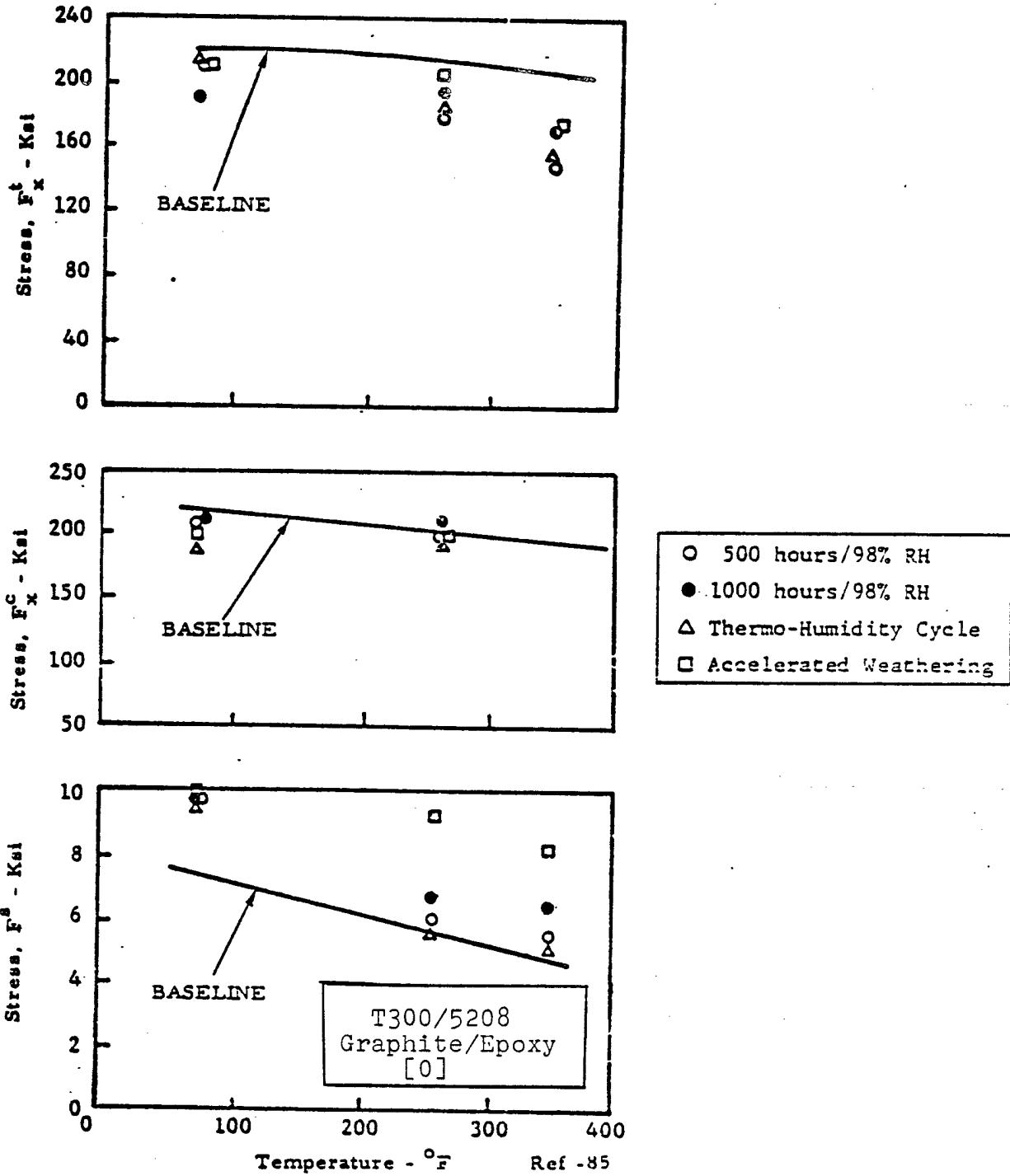

FIGURE 3-8 EFFECT OF HUMIDITY TREATMENTS ON LONGITUDINAL AND SHEAR STRENGTH PROPERTIES from Reference 2

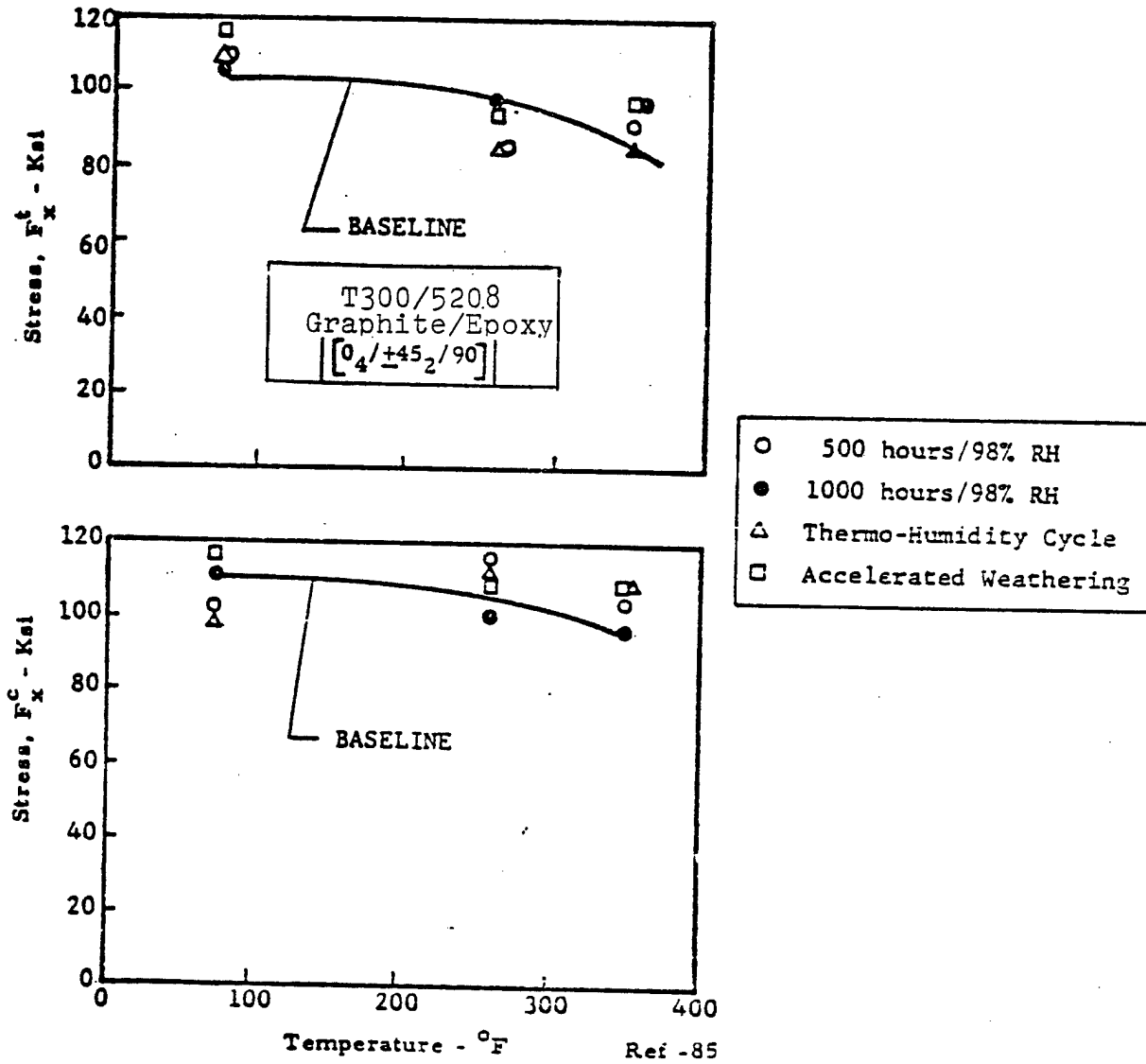
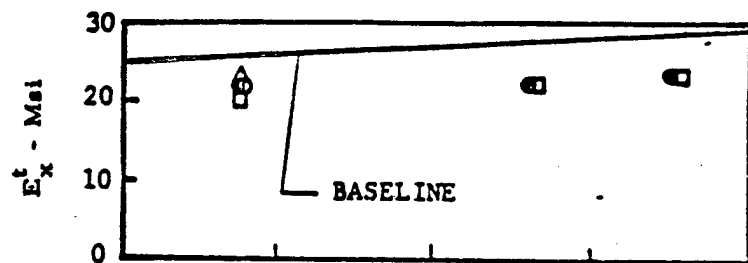
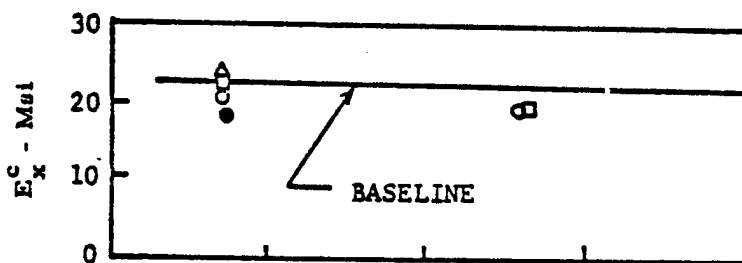

FIGURE 3-9 EFFECT OF VARIOUS HUMIDITY TREATMENTS ON LONGITUDINAL STRENGTH PROPERTIES from Reference 2



T300/5208  
Graphite/Epoxy  
[0]



- 500 hours/98% RH
- 1000 hours/98% RH
- △ Thermo-Humidity Cycle
- Accelerated Weathering

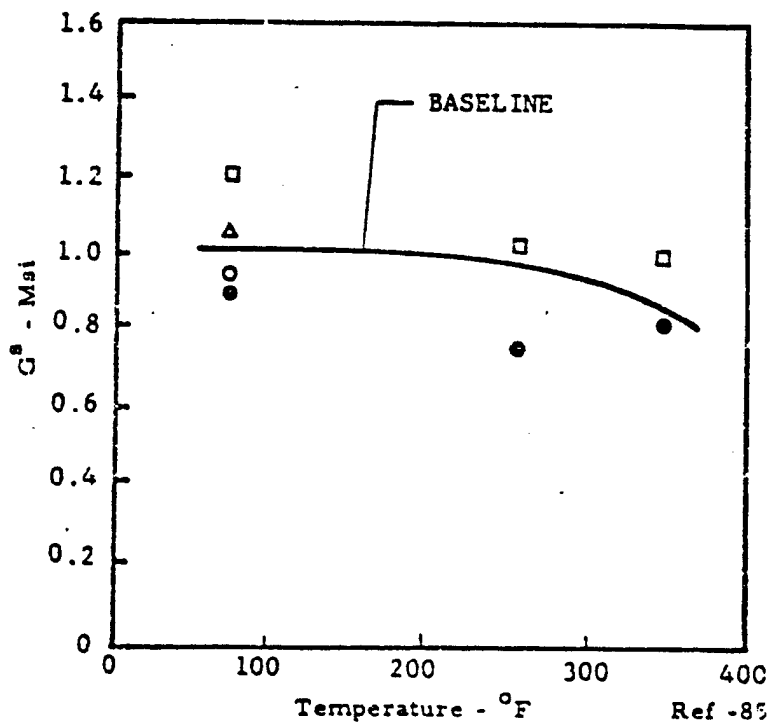

FIGURE 3-10 EFFECT OF VARIOUS HUMIDITY TREATMENTS ON LONGITUDINAL AND SHEAR ELASTIC PROPERTIES from Reference 2

core was tested with flatwise tension tests. There were significant measured strength losses for these tests averaging 41.3% for the 5% salt spray and 78.0% for the synthetic seawater plus sulphur dioxide spray environments. Similar results for aluminum skin bonded to aluminum honeycomb core were also very high at 29.8 and 69.1% respectively. In addition the adhesive used was slightly conductive which may have contributed to the poorer showing of the graphite. For both types of specimens however, it appears that the bonding may be the more critical component, rather than adherend degradation, which needs further study to establish the environmental effects. The effects of galvanic corrosion according to Reference 4 can be minimized by the application of an epoxy primer and a polyurethane paint in addition to using standard wet fastener installation techniques when metallic fasteners are used.

The effect of natural weathering, including moisture and sunlight, was studied in Reference 5 where coated and uncoated graphite specimens were subjected up to 18 months of natural weathering. The effect on tension, compression, and short beam shear were established for the specimens which were subjected to the natural weathering while loaded to an approximately 4000  $\mu$  in/in tensile strain. What was found from the tests was that certain graphite systems are less affected by the weathering than others but that in most cases proper surface coating provides sufficient protection.

Figure 3-11 presents the data from Reference 6 where coated and uncoated graphite/epoxy specimens are tested at room temperature in compression and short beam shear after exposure to one of the environments noted. The effect of immersion in typical aircraft solvents is seen to be small, with coated specimens, in most cases, yielding better results than the uncoated ones.

Graphite/epoxy composites can be abraded by wind, rain, dust and sand. The amount of erosion can be related to particle size, quantity, velocity and duration. Experience gained through the use of graphite/epoxy on automotive structures has indicated that the damage from these low energy level impacts can be negated with the use of coating materials such as neoprene or polyurethane. It is assumed that the erosion potential for the ejection seat would not be more severe than for the automotive structures tested.

During ejection, the composite seat could be subjected to a thermal shock at the same time it is undergoing very high mechanical loadings. With a 15,000 psi preload, a thermal pulse caused a 20% degradation in the tension and compression strengths for the graphite/epoxy system of Reference 7 while the stiffness was unaffected. The actual reduction for the seat would be reduced considerably due to the large amount of insulating materials surrounding the seat; including the pilot, seat padding, parachute, and electrical equipment.

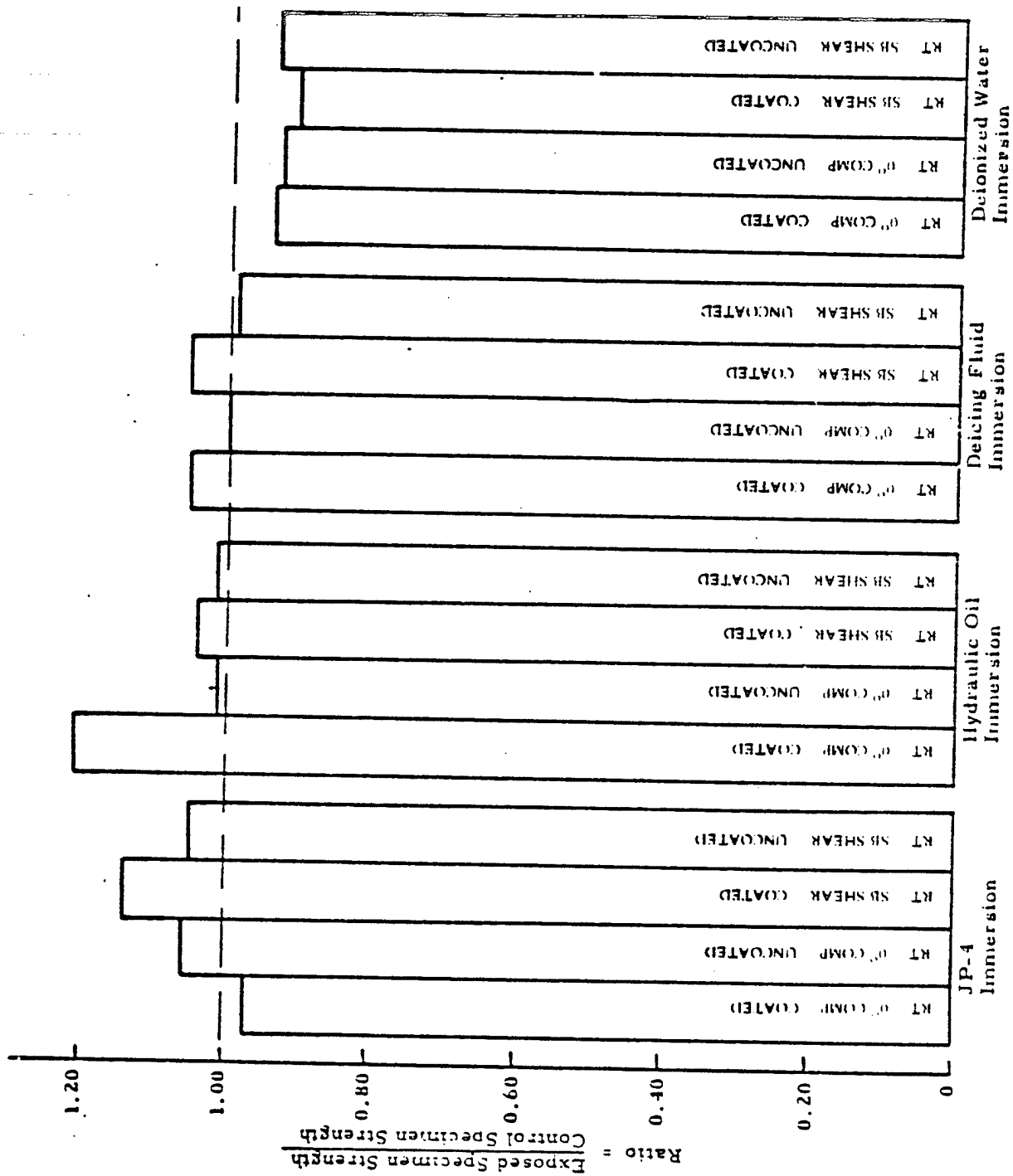

FIGURE 3-11 BAR CHART OF EFFECT OF IMMERSION ON STRENGTH PROPERTIES OF AS/3501-5 GRAPHITE/EPOXY LAMINATES

from Reference 5

Other environmental conditions, which have received less emphasis and which will be mentioned briefly here have been radiation exposure, lightning strike and fungus attack. From Reference 7, no degradation in flexure or interlaminar shear strengths were observed for unidirectional graphite/epoxy after exposure to nuclear radiation. Graphite filament/organic matrix composites are susceptible to lightning damage. The composite does not dissipate the resulting P-static electrical charges nor does it provide electromagnetic shielding. The results of a lightning strike can be in the form of severe laminate damage although it is generally local in nature. Finally through the addition of suitable chemical compounds, most epoxies and polyester can be formulated to be resistant to any fungus attack.

#### 4.0 Comparison of Costs for Aluminum and Composite MPES Seats

Table 4-1 presents the cost information for the three MPES seats considered in this study; the Baseline, Modified, and Composite as initially differentiated in Section 1.

##### 4.1 Production Costs

In projecting the production costs for the two aluminum seats the costs of the Modified version was based on the modifications of the Baseline seat presented in Figures 2-1 through 2-15 while the Baseline seat costs were established by applying standard production practices to the existing prototype seats. On this basis, the production cost for the Baseline seat is observed to be 9.0% more than the cost of the Modified version for a 2000 seat production run. This is to be expected because of the similarity of the Baseline and Modified seats.

For production quantities as low as 100 seats it turns out to be cost effective to employ the use of castings, forgings and extrusions as opposed to machining. Hence, there are no significant price breaks at a particular number of seats for all three designs. The reduction in price with increased number of seats comes about because of normal economic factors including lower material costs with larger quantity purchases and the benefits of a learning curve. The cost for the composite seat includes graphite material costs quoted for current prices.

TABLE 4-1  
(IN PERCENTAGES)  
COST ESTIMATES FOR THREE MPES SEAT CONCEPTS

PRODUCTION QUANTITY	BASELINE		Unit Cost**	MODIFIED		Unit Cost**	COMPOSITE		Unit Cost**		
	Mat'l*	Hours		Mat'l*	Hours		Mat'l*	Hours			
100	\$800	460	\$190,000	\$MAX(100%) ea.	\$700	425	\$160,000	\$1250	340	\$190,000	78% MAX ea.
400	700	310	190,000	68%MAX	560	288	160,000	1000	230	190,000	54% MAX
1000	630	250	190,000	56% MAX	510	232	160,000	900	195	190,000	46% MAX
2000	600	200	190,000	45% MAX	475	186	160,000	830	155	190,000	38% MAX

\* Includes a \$100 charge for gun drilling two parts.

\*\* Does not include the pro-rated tool cost.

However, in less than a year there is a very strong possibility that the prices for the particular graphite/polyester system considered will drop from \$48 per pound, used in preparing Table 4-1, to \$33 per pound which would result in a \$170 material cost savings for all composite quantities listed in Table 4-1. An estimated increase in cost of approximately \$150 per composite seat would be experienced if graphite fiber reinforced HMC was used to save weight compared to the glass HMC used in the costs in Table 4-1.

For the additional change to the Modified MPES seat described in Figure 2-16, the delta reduction in cost from Table 4-1 is \$100 per seat. While the actual reduction will vary slightly with the number of seats produced, the \$100 value is a reasonable estimate. Similarly the delta reduction in cost attributed to the modification shown in Figure 2-17 is \$160 per seat.

#### 4.2 Composite Prototype Costs

Including the detailed engineering effort and a set of tools to fabricate the composite ejection seat, the estimated cost of one (1) prototype seat is 34% greater than the cost if purchased in quantities of 100 and the estimated cost for five (5) prototype seats is 60% greater than the cost of an equal number of units if purchased in quantities of 100. It is felt that the only way to accurately assess the molding techniques, the nesting configuration and the overall structural integrity would be to build a set of molds even for the prototype seats. With these tooling costs of approximately \$120,000 it is not unexpected that the prototype costs are high.

## 5.0 Recommendations and Conclusions

The proposed Composite MPES seat concept is believed to be structurally acceptable, and it offers a cost reduction over aluminum MPES seat structures. The Composite prototype cost is, however, high, due to the necessity of making a full set of molds and also due to developing the required molding technology.

What is needed and also recommended is to investigate alternate fabrication approaches while retaining the overall Composite structural configuration as proposed in this report. The objective of this recommended study would be to simplify the Composite concept by evaluating alternate core fabrication details. This study would result in a lower cost prototype development and would possibly lower the weight and cost in production.

Without the benefit of tests, the approach chosen in this report for the core construction was fairly conservative. A number of ideas, including compression molding just the ribs, or using a built-up egg crate construction have been suggested for redesigning the core. Some of these suggestions provide excellent possibilities of success but must be more fully explored and simple mechanical tests should be conducted to validate the approaches. When this proposed phase of simplifying the Composite seat design is complete there would be a greater assurance of success and a greater justification for undertaking a prototype development program.

## 6.0 References

1. "Engineering Design Handbook - Short Fiber Plastic Base Composites," Army Material Command Pamphlet No. 706-313, July 1975.
2. "Development of Engineering Data on the Mechanical and Physical Properties of Advanced Composite Materials," AFML - TR-74-266, IIT Research Institute, February 1975.
3. Fischer, P. and DeLuccia, J.J., "Effects of Graphite/Epoxy Composite Materials on the Corrosion Behavior of Aircraft Alloys," Environmental Effects on Advanced Composite Materials, ASTM STP 602, 1976.
4. "Advanced Composites Design Guide", Air Force Materials Laboratory, January 1973.
5. Trabocco, R.E. and Stander, M., "Effect of Natural Weathering on the Mechanical Properties of Graphite/Epoxy Composite Materials," Environmental Effects on Advanced Composite Materials, ASTM STP 602, 1976.
6. "Advanced Development of Not-Critical-To-Flight-Safety Advanced Composite Aircraft Structures," AFML-TR-74-38, Northrop Corporation/Aircraft Division, March 1974.
7. "Advanced Composite Data for Aircraft Structural Design," AFML-TR-70-58, North American Rockwell, Los Angeles Division.

D I S T R I B U T I O N   L I S T

REPORT NO. NADC-79011-60

AIRTASK NO. F41400000

Work Unit No. ZA604

No. of Copies

NAVAIRSYSCOM, AIR-950D. . . . .	7
(2 for retention)	
(2 for AIR-340B)	
(1 for AIR-531)	
(1 for AIR-5312G)	
(1 for AIR-4114A3)	
AFFDL, Wright-Patterson AFB (Life Support SPO), OH 45433 .	1
Army Materials and Mechanics Research Center, Watertown, MA 02172 . . . . .	1
AVRADCOM, St. Louis, MO 63166 (Attn: ORDAU-E). . . . .	1
Dept. of Army, Applied Technology Lab., Ft. Eustis, VA 23604 (Attn: DAVDL-EV-ASV) . . . . .	1
U. S. Army Aviation Material Lab., Ft. Eustis, VA 23604. .	1
DDC . . . . .	12
NASA, Langley Research Center, Hampton, VA 23665 . . . . .	1
NATPARACHUTETESTCEN, El Centro, CA 92243 (Attn: 6401). . .	1
NAVAIRTESTCEN, Patuxent River, MD 20670 (SY 71). . . . .	1
AVCO Corp. (Specialty Materials Div.), Lowell, MA . . . . .	1
A.R.A. Inc., W. Covina, CA 91790 . . . . .	1
Bell Helicopter Textron, Fort Worth, TX 76101. . . . .	1
Boeing Aircraft Corp., Seattle, WA 98124 . . . . .	1
Boeing-Vertol Co., P. O. Box 16858, Phila., PA 19142 . . .	1
Budd Co., Fort Washington, PA 19034 . . . . .	1
Douglas Aircraft Co., Long Beach, CA 90846 . . . . .	1
East-West Industries, Farmingdale, NY 11735 . . . . .	1
General Dynamics Corp., St. Louis, MO. . . . .	1
Grumman Aerospace Corp., Bethpage, NY 11714. . . . .	1
Hughes Helicopters, Culver City, CA 90230 . . . . .	1
Lockheed Aircraft Corp., Burbank, CA 91503 . . . . .	1
North American Rockwell, Columbus, OH 43216 . . . . .	1
Northrop Aircraft Corp., Burbank, CA . . . . .	1
Sikorsky Aircraft Corp., Stratford, CN 06602 . . . . .	1
Simula Inc., Tempe, AZ 85282 . . . . .	1
Stencil Aero Engineering Corp., Asheville, NC 28803 . . . .	1
Teledyne-Ryan, 2701 Harbor Dr., San Diego, CA 92112 . . . .	1
Vought Corp. Dallas, TX 75222 . . . . .	1

8400265