

REPORT DOCUMENTATION PAGE

Form Approved
OMB No. 074-0188

Public reporting burden for this collection of information is estimated to average 1 hour per response, including the time for reviewing instructions, searching existing data sources, gathering and maintaining the data needed, and completing and reviewing this collection of information. Send comments regarding this burden estimate or any other aspect of this collection of information, including suggestions for reducing this burden to Washington Headquarters Services, Directorate for Information Operations and Reports, 1215 Jefferson Davis Highway, Suite 1204, Arlington, VA 22202-4302, and to the Office of Management and Budget, Paperwork Reduction Project (0704-0188), Washington, DC 20503

1. AGENCY USE ONLY (Leave blank)	2. REPORT DATE 29 Jan 1997	3. REPORT TYPE AND DATES COVERED Final
----------------------------------	-------------------------------	---

4. TITLE AND SUBTITLE ADVANCED DISTRIBUTED SIMULATION TECHNOLOGY (ADST-II) FORCE PROTECTION EXPERIMENT III	5. FUNDING NUMBERS N61339-96-D-0002
--	--

6. AUTHOR(S)	
--------------	--

7. PERFORMING ORGANIZATION NAME(S) AND ADDRESS(ES) Lockheed Martin Corporation Information Systems Co. 12506 Lake Underhill Road Orlando, FL 32825	8. PERFORMING ORGANIZATION REPORT NUMBER ADST-II-CDRL-018R-9600423
--	--

9. SPONSORING / MONITORING AGENCY NAME(S) AND ADDRESS(ES) NAWCTSD/STRICOM 12350 Research Parkway Orlando, FL 32826-3224	10. SPONSORING / MONITORING AGENCY REPORT NUMBER
--	---

11. SUPPLEMENTARY NOTES

12a. DISTRIBUTION / AVAILABILITY STATEMENT A - Approved for public release; distribution unlimited.	12b. DISTRIBUTION CODE
--	------------------------

13. ABSTRACT (*Maximum 200 Words*)
The Force Protection Experiment III (FPE III) was an experimental exercise conducted at the Mounted Warfare Test Bed (MWTB) at Fort Knox, KY from October 28 to December 5, 1996. The experiment was performed as Delivery Order (DO) #0019 under the Lockheed Martin Advanced Distributed Simulation Technology II (ADST II) Contract administered by the U.S. Army Simulation, Training, and Instrumentation Command (STRICOM). The experiment was sponsored by three Government agencies: Program Manager, Combat Identification; Tank Automotive & Armaments Command (TACOM) Research, Development, & Engineering Center (TARDEC); and the Mounted Maneuver Battle Lab (MMBL), Fort Knox, KY. The experiment utilized a synthetic environment that employed virtual simulations to depict an Armor Company executing four basic company-level scenarios in realistic combat situations in various experimental configurations. The scenarios were developed to be run on the Fort Hood terrain database, and included Attack, Defend and Movement to Contact vignettes. These scenarios were designed to produce survivability events, provide fratricide risk, and induce the commanders to make tactical decisions which affected battle outcomes.

14. SUBJECT TERMS	15. NUMBER OF PAGES 37
	16. PRICE CODE

17. SECURITY CLASSIFICATION OF REPORT UNCLASSIFIED	18. SECURITY CLASSIFICATION OF THIS PAGE UNCLASSIFIED	19. SECURITY CLASSIFICATION OF ABSTRACT UNCLASSIFIED	20. LIMITATION OF ABSTRACT UL
--	---	--	----------------------------------

DTIC QUALITY INSPECTED 2

January 29, 1997

**ADVANCED DISTRIBUTED
SIMULATION TECHNOLOGY II
(ADST II)
FORCE PROTECTION EXPERIMENT III
FPE III #0019
CDRL AB03
FINAL REPORT**



FOR: NAWCTSD/STRICOM
12350 Research Parkway
Orlando, FL 32826-3224
N61339-96-D-0002
DI-MISC-80711

BY: Lockheed Martin Corporation
Martin Marietta Technologies, Inc.
Information Systems Company
12506 Lake Underhill Road
Orlando, FL 32825

Approved for public release; distribution is unlimited

19970620 023

EXECUTIVE SUMMARY.....	vii
1. INTRODUCTION.....	1
1.1 Purpose.....	1
1.2 Contract Overview.....	1
1.3 Experiment Overview.....	1
1.4 Technical Overview.....	2
2. APPLICABLE DOCUMENTS.....	2
2.1 Government.....	2
2.2 Non-Government.....	2
3. SYSTEM DESCRIPTION.....	3
3.1 System Configuration and Layout.....	3
3.2 Description of System Components.....	5
3.2.1 Appliqué.....	5
3.2.2 Tactical Internet Model/Internet Controller.....	6
3.2.3 Precision Lightweight Global Positioning System Receiver (PLGR).....	6
3.2.4 E-BCIS.....	6
3.2.5 IDS.....	7
3.2.6 Appliqué LAN Interface.....	7
3.2.7 Manned Simulators.....	7
3.2.8 ModSAF Operations.....	8
3.2.8.1 ModSAF Enhancements.....	8
3.2.9 Data Logger.....	8
3.2.9.1 Audio/Video Capture.....	9
3.2.10 Time Stamper.....	9
3.2.11 Stealth.....	9
3.2.12 DIS LAN Network.....	10
3.3 Database and Scenario Development.....	10
4. CONDUCT OF THE EXPERIMENT.....	10
4.1 Troop Training.....	10
4.2 Pilot Test.....	10

4.3 Experiment and Trial Runs	11
5. OBSERVATIONS AND LESSONS LEARNED	14
5.1 Mini-FAS	14
5.2 Development and Integration.....	15
5.3 Experiment.....	19
5.4 Overall.....	20
6. CONCLUSION	22
7. POINTS OF CONTACT	24
9. ACRONYMS.....	27
Appendix A - Test Readiness Review Issues.....	A-1
Appendix B - M1A2 Simulator Reliability Issues.....	B-1

List of Figures

FIGURE 1 FPE III EXPERIMENT ASSET LAYOUT AT MWTB.....4

FIGURE 2 FPE III HARDWARE AND INTERFACE DIAGRAM.....5

List of Tables

TABLE 1 ADST II MWTB ASSETS.....4

TABLE 2 EXPERIMENT MATRIX.....12

EXECUTIVE SUMMARY

The Force Protection Experiment III (FPE III) was an experimental exercise conducted at the Mounted Warfare Test Bed (MWTB) at Fort Knox, KY from October 28 to December 5, 1996. The experiment was performed as Delivery Order (DO) #0019 under the Lockheed Martin Advanced Distributed Simulation Technology II (ADST II) Contract administered by the U.S. Army Simulation, Training, and Instrumentation Command (STRICOM). The experiment was sponsored by three Government agencies: Program Manager, Combat Identification; Tank Automotive & Armaments Command (TACOM) Research, Development, & Engineering Center (TARDEC); and the Mounted Maneuver Battle Lab (MMBL), Fort Knox, KY. The experiment utilized a synthetic environment that employed virtual simulations to depict an Armor Company executing four basic company-level scenarios in realistic combat situations in various experimental configurations. The scenarios were developed to be run on the Fort Hood terrain database, and included Attack, Defend and Movement to Contact vignettes. These scenarios were designed to produce survivability events, provide fratricide risk, and induce the commanders to make tactical decisions which affected battle outcomes. The objectives of the effort were:

1) To investigate the effects on mission performance at Platoon and Company levels of various combinations of a digital command and control system, a friendly vehicle identification system, a vehicle hit avoidance system, and a supplemental digital situational awareness system.

2) To investigate the effects of an interrogation and response combat identification system on fratricide occurrence and gunnery performance.

3) To investigate the effects of a supplemental digital communication system on the timeliness and accuracy of a digitized local battlefield information and Single Channel Ground and Airborne Radio System (SINGARS) net loading.

4) To investigate the effects on vehicle survivability of hit avoidance sensors and countermeasures within the armor Platoon.

5) To investigate the effects on vehicle survivability of passing hit avoidance information locally using a supplemental digital communication system.

6) To identify combat identification modeling parameters for input to constructive combat models.

7) To investigate the requirement for new or modified tactics, techniques, and procedures introduced by Enhanced Battlefield Combat Identification System (E-BCIS) and the Integrated Defense System (IDS).

Development of the software modifications to Modular Semi-Automated Forces (ModSAF) and the initial integration of software models was conducted at the Operational Support Facility (OSF) in Orlando, FL from July 15 to August 20, 1996. The final integration phase was completed at the MWTB from September 3 to 27, 1996. Additionally, the E-BCIS

model development was performed by MITRE in Bedford, MA and the IDS model development was performed by Optimetrics, Inc (OMI) in Ann Arbor, MI.

In accordance with the Government Statement of Work, the experiment's test trial window was six (6) weeks. This six week period included five weeks to execute the trial run matrix and an additional week scheduled for make-up of non-validated runs, if required. The experiment baseline case was comprised of a non-digital (radio voice only) Command and Control System. Subsequently, additional systems (Appliqué, IDS, and E-BCIS) were separately added and/or combined with the baseline case in an effort to detect the incremental contribution of each system.

The entire trial run matrix was executed within the allocated five weeks with no additional time required for make-up of non-validated runs. As a result, the sixth week was made available for E-BCIS only excursion runs and a demonstration of the final virtual simulation version of the IDS. The activities of this week had no impact on analysis of runs in the matrix or on schedule.

In accordance with the Government SOW, this Final Report includes a description of the experiment, its conditions and conduct, and lessons learned. This report addresses the interconnectivity of simulation systems, modifications to both ModSAF and the manned simulators, and the integration of Government Furnished software models. This report does not include discussion of data analysis nor conclusions as to whether the customer(s) achieved their objectives of the experiment.

1. INTRODUCTION

1.1 Purpose

The purpose of this final report is to document the ADST II effort which supported FPE III. This report includes a full description of the experiment, its conditions, and lessons learned. A more detailed "blueprint" of the FPE III system's architectural design is found in the separately prepared document entitled the "Hardware Design and Configuration Document." (HDCD) (CDRL AB03).

1.2 Contract Overview

FPE III was performed as DO #0019 under the Lockheed Martin Corporation (LMC) ADST II contract with STRICOM. The contract required LMC to perform a Mini-Feasibility Analysis Study (Mini-FAS) to determine the best technical approach for providing a Command and Control Tactical Display (C2TD) system for use in the experiment, and to determine the best technical approach for integrating the IDS and E-BCIS with the C2TD. The Mini-FAS was successfully completed in the month of June. At the conclusion of the Mini-FAS, STRICOM and LMC conducted a customer decision brief on July 2, 1996. The purpose of this decision briefing was to obtain customer approval of the Mini-FAS findings and recommendations, permission to revise the proposal, and permission to proceed with the proposed experiment timeline. A detailed description of the activities and findings of the Mini-FAS are documented in the initial Mini-FAS Report (CDRL AB01) submitted July 30, 1996 and the final version dated October 18, 1996.

1.3 Experiment Overview.

The purpose of FPE III was to use man-in-the loop simulators and simulated forces to evaluate the effect of combining vehicle survivability, combat identification, and digital communication systems on ground combat vehicles operating as a Company element of a Battalion Level Combined Arms Task Force. Data was collected to capture soldier responses to survivability events and the command and battle staff's ability to use the additional experimental digital information to improve their battlefield performance. The experiment was designed to provide the Government with the opportunity to review and revise: operational effectiveness; tactics, techniques, and procedures (TTPs); soldier-machine interfaces; training; and input parameters for constructive modeling. The experiment employed four manned M1A2 simulators (configured as M1A1 variants) as a Platoon within a Blue Armor Company. The remainder of the Company was rounded-out with two additional tank platoons of Blue ModSAF; two ModSAF Bradley Fighting Vehicles as Scouts; and a Company Commander and Executive Officer role-playing from a ModSAF workstation. The Blue Force (BLUEFOR) conducted tactical operations against a doctrinally approved and depicted Opposing Force (OPFOR) ModSAF threat.

1.4 Technical Overview

The technical approach to the Force Protection III Experiment involved the conduct of the Mini-FAS, integrating the Appliqué C2TD selected by the Mini-FAS, integrating the IDS and E-BCIS with the selected C2TD system, modification to ModSAF version 2.1, and modification of the Precision Lightweight Global Positioning System (GPS) Receiver (PLGR). Details on the modifications to ModSAF and PLGR are documented in the Version Description Documents (VDDs), (CDRL AB04). The following is a short synopsis of the technical integration effort for the experiment.

ModSAF development and initial integration of software model changes were conducted at the Operational Support Facility (OSF) during the test and development portion of integration. This initial work effort was shipped and reinstalled at the MWTB and subsequently completed during the four week on-site integration period. Once the synthetic environment functional tests were completed, Fort Knox conducted troop training and a Pilot Test. After the Pilot Test, a week was used to make final fixes and provided additional time for troop training. The Test Readiness Review (TRR) was held on October 24, 1996 to freeze the experiment configuration and receive approval to start the experiment, which began on October 28, 1996. The actual experiment period lasted five weeks during which 96 different iterations were executed using four basic scenarios. A sixth week, which was available for conduct of make-up experiment trials, was not required. This sixth week was therefore made available for E-BCIS only excursion runs and a demonstration of the final virtual simulation version of the IDS.

2. Applicable Documents

2.1 Government

-ADST II Work Statement for Force Protection Experiment III (FPE III), May 24, 1996, AMSTI-96-WO39, Version 2.0

-ADST II Work Statement for Force Protection Experiment III (FPE III), July 30, 1996, AMSTI-96-WO39, Version 3.0

-Battle Lab Experiment Plan (BLEP) for Force Protection Experiment III (FPE III), ATZK-MW, Fort Knox, KY, April 24, 1996

-Battle Lab Experiment Plan (BLEP) for Force Protection Experiment III (FPE III), ATZK-MW, Fort Knox, KY, August 15, 1996

2.2 Non-Government

-ADST II Technical Approach for Force Protection Experiment III (FPE III), April 30, 1996, ADST II-TAPP-018R-9600048B

-ADST II ECP Technical Approach for Force Protection Experiment III (FPE III), July 24, 1996, ADST II-TAPP-018R-9600228

-ADST II CDRL AB01, Force Protection Experiment III (FPE III) Mini-FAS Report, July 30, 1996, ADST-II-CDRL-018R-9600223

-ADST II CDRL AB01, Force Protection Experiment III (FPE III) Mini-FAS Report, October 18, 1996, ADST-II-CDRL-018R-9600223A

-ADST II CDRL AB04, Force Protection Experiment III (FPE III) Cold Start Manual, ADST-II-CDRL-018R-9600424

- ADST II CDRL AB04, Force Protection Experiment III (FPE III) VDD-ModSAF, ADST-II-CDRL-018R-9600425

- ADST II CDRL AB04, Force Protection Experiment III (FPE III) VDD-PLGR, ADST-II-CDRL-018R-9600437

- ADST II CDRL AB04, Force Protection Experiment III (FPE III) VDD- Appliqué, Interface, ADST-II-CDRL-018R-9600438

- ADST II CDRL AB04, Force Protection Experiment III (FPE III) VDD-IDS Tones, ADST-II-CDRL-018R-9600439

- ADST II CDRL AB04, Force Protection Experiment III (FPE III) VDD-M1A2, ADST-II-CDRL-018R-9600478

-ADST II CDRL AB04, Force Protection Experiment III (FPE III) Hardware Design and Configuration Document, ADST-II-CDRL-018R-9600426

-ADST II, Force Protection Experiment III (FPE III) Design Review SEIT, August 23, 1996, ADST-II-SEIT-018R-9600449

-ADST II, Force Protection Experiment III (FPE III), Post DO SEIT, December 19, 1996, ADST-II-SEIT-018R-9600450

3. System Description

3.1 System Configuration and Layout

The Mounted Warfare Test Bed at Fort Knox, KY, contains a variety of vehicle simulators, networks, Semi-Automated Forces (SAF) capabilities, displays for monitoring the battlefield, utilities to facilitate exercises, automated data collection capabilities, and data reduction and analysis subsystems. The MWTB simulation and support platforms used for FPE III are depicted in Figure 1.

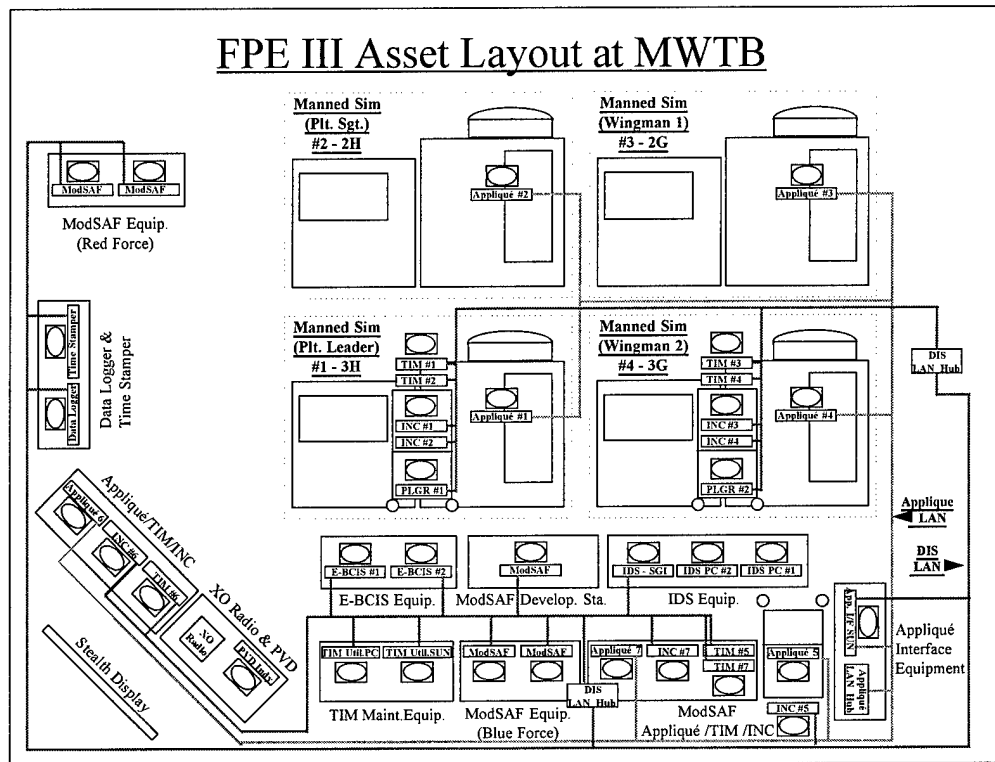

Figure 1 FPE III Asset Layout at MWTB

The experiment was conducted using assets interconnected on Ethernet LANs via thin net cable. Simulation assets used Distributed Interactive Simulation (DIS) 2.03 protocol. Table 1 lists assets used at the MWTB.

ADST II ASSET	PURPOSE	PROTOCOL
Modified M1A2 Simulator	M1A1 Simulator for Manned Tank Platoon	DIS
Stealth	Battlefield Display for Company Commander Role-player	DIS
ModSAF Workstations	Semi-Automated Forces for OPFOR, two BLUFOR M1 Platoons, & Scout Section	DIS
SINCGARS Face Plates	Simulated Radio Communications	DIS
Plan View Display	Terrain Map of the battlefield for Exercise Control	DIS
Data Loggers	Record of DIS PDUs for Data Collection & Analysis	DIS
DIS Time Stamper	Time Stamp of DIS PDUs for Data Collection & Analysis	DIS

Table 1 ADST II MWTB Assets

In addition to the manned simulators and assets listed in Table 1 above, there were seven SGIs, two Sun workstations, twenty two full size PCs, and four portable PCs required to support the experiment. Figure 2 depicts the FPE III Hardware and Interface Diagram to support the experiment.

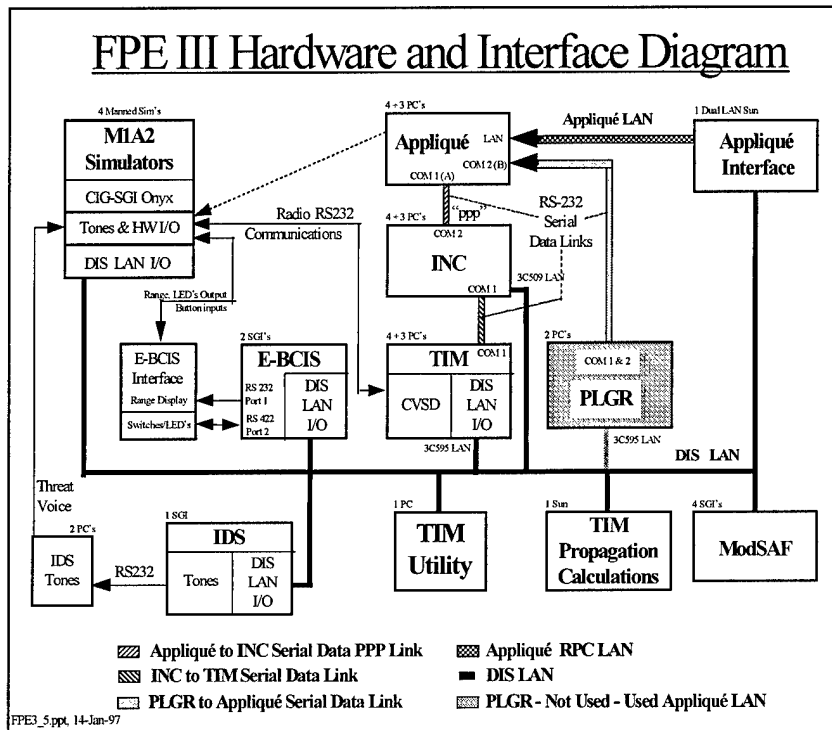

Figure 2 FPE III Hardware and Interface Diagram

3.2 Description of System Components

This section discusses the description, functionality and operation of the system components, which includes the GFE models and their integration with the hardware at the MWTB. Additional technical information, such as a more detailed technical description, specific hardware configuration characteristics, basic operating instructions, and drawings are provided separately in the HDCD.

3.2.1 Appliqué

The Appliqué Command and Control Tactical Display software was developed by TRW of Carson, CA and provided by the Program Manager Appliqué. FPE III used Appliqué version 1.01a which was the latest and most mature of seven versions developed at the conclusion of the Mini-FAS. Subsequent versions were developed during the execution of this experiment. The Appliqué computer display was mounted to the left of the Tank Commander in the manned simulator. It provided the Commander with a color map showing accurate, timely Platoon member locations, threat warnings, and map overlays. Appliqué allowed the Commander to send and receive Intelligence Reports, Contact Reports, and Fragmentary Orders.

3.2.2 Tactical Internet Model (TIM)

The Tactical Internet Model (TIM) was provided by MITRE Corporation and the Communications and Electronics Command (CECOM). The TIM helped to provide a simulation of realistic voice and data radio communications. The TIM includes a simulation of the Internet Controller (INC) which serves as a router for the exchange of data messages within the Tactical Internet. Additionally, a separate PC hosted the TIM Utilities Operations, which provided automated initialization and maintenance functions. This same PC also functioned as the TIM Propagation Server, which provided terrain propagation calculations to each of the individual TIM PCs for use in creating realistic communication delays and corruption due to terrain and distance.

3.2.3 Precision Lightweight Global Positioning System Receiver (PLGR) Model Operations

The Government SOW required a simulated position location system software model be used to provide current location of host platforms. The system would provide a position with statistically induced errors as would be measured by a realistic GPS system. With the Appliqué system it was anticipated that the Experimental Force (EXFOR) Appliqué PLGR or an alternate PLGR simulation would be used.

As a result of the Mini-FAS and with the selection of Appliqué, the EXFOR PLGR model was modified to work with Appliqué version 1.01a. This model was used in the Functional Test and modified after the Pilot Test to fix some anomalies that appeared. Although the PLGR model was operational prior to the start of the experiment, there was and still is a PLGR/Appliqué 1.01a communication problem which causes occasional communications lock-ups. Due to the complexity of the experiment, the integration and involvement of numerous software models, the lengthy start up time required to bring up all subcomponents prior to the start of a trial run, and the ability of the Appliqué LAN interface to provide instant and accurate position location, the PLGR model was not used.

The decision to remove the PLGR from the experiment and use the Appliqué LAN interface for this functionality instead was recommended and approved by all the customers at the Test Readiness Review. This decision provided a savings of over one hour per day in start up time, which in turn provided more simulator run time for the actual experiment. The issue of Appliqué providing perfect location in lieu of the normal GPS induced error was overcome by the fact that the induced error for the Fort Hood database was 10-30 feet, and the fact that the entity icon on the Appliqué screen was equivalent to 200 meters in size. Therefore, the error was transparent to the troops and the experiment. Additionally, it was noted that the error induced by using single precision float format for the new PLGR position messages also included a 10-30 foot error.

3.2.4 E-BCIS Model Operations

The E-BCIS was provided by MITRE Corporation, Bedford, MA through PM Combat ID. This system provided situational awareness for the crew and adjacent members of the Platoon and Company. This situational awareness was provided by both information gathering and a friendly position location reporting function. Information gathering was provided by an

interrogation and response function wherein either the Gunner or Tank Commander could initiate a query by lasing on a target. Initiation of a lase would simultaneously initiate a directional millimeter-wave (MMW) signal broadcast (a query), which would be picked up by other friendly vehicles in the signal's path. Friendly vehicles receiving the query would in turn respond with an omni-directional MMW signal indicating their identity. The result of the query would be a "Friend," "Friend-in-Sector," or an "Unknown" response. This response was provided to the crew via a tone through the crew headsets, an icon displayed on the Appliqué tactical display, and lights in both the Commander's and Gunner's sights. In addition to the manned simulators, E-BCIS was also configured to obtain responses from Blue ModSAF vehicles.

E-BCIS also provides an automatic position reporting capability via a digital data link (DDL). With DDL, each E-BCIS equipped vehicle sends out a periodic (heart beat) MMW signal containing the vehicle's current GPS position. Every other E-BCIS equipped vehicle within a 1 Km range receives this data and records it in its own situational awareness data base. These locations are then displayed on the Appliqué screen.

3.2.5 IDS Operations

The IDS was provided by Optimetrics, Inc, Ann Arbor, MI through TARDEC. This system operated within the simulator and provided early warning and detection of threat munitions directed toward the vehicle. After detection and warning were completed, a countermeasure device was employed to protect the vehicle against the threat. IDS was configured with a Missile Warning Receiver, Missile Countermeasure Device, and smoke. The IDS worked in the "automatic mode" only (automatic detection, classification, and release of countermeasures).

The detection and warnings were provided to the crew by tones and voice, and followed by a visual display on the Appliqué screen. The displays on the Appliqué screen occurred at the next screen update, which ran on a twenty second update cycle.

3.2.6 Appliqué LAN Interface

In addition to being connected to simulated TIM radios via the INC, each Appliqué was interconnected via an Appliqué LAN. An Appliqué LAN Interface workstation provided a communications bridge between the Appliqué and DIS LANs. This facilitated the passing of certain ModSAF entity locations, E-BCIS data, and IDS data over the DIS network to the Appliqués. The Appliqué LAN Interface converted the necessary data from DIS PDUs into Variable Message Format (VMF) messages in User Data Protocol (UDP) packets for communication to the Appliqués. The Appliqué LAN was only used to receive VMF messages from the Appliqué LAN Interface and not for communications from one Appliqué to another. This level of communication was performed via the TIM/INC radio emulator for realistic communications within the synthetic environment.

3.2.7 Manned Simulators

Four M1A2 simulators were used for FPE III. The simulators represented a Tank Platoon as part of an Armor Company. Each simulator was modified to replicate the M1A1 variant with

E-BCIS, and had an Appliqué Command and Control Tactical Display (C2TD) installed. The C2TD was a Compaq Elite Laptop Computer purchased for the experiment. The computer is running with the Santa Cruz Operating System (SCO) UNIX and Appliqué software version 1.01a.

3.2.8 ModSAF Operations

ModSAF version 2.1 was used for FPE III. ModSAF was used for BLUFOR round-out and OPFOR. BLUFOR ModSAF provided the two additional platoons required to round-out the Armor Company, plus the Company Commander and Executive Officer, and a Scout Section. OPFOR were provided in a configuration of a Motorized Rifle Battalion to complete the scenario requirements.

3.2.8.1 ModSAF Enhancements

ModSAF was enhanced/modified for FPE III to meet specific requirements. A library "Lib Appliqué" was added to send data PDUs to the Appliqué interface. These data PDUs were used to provide the ModSAF entities positions to the Appliqué systems. Additionally, new munitions with associated damage tables (Sagger, Songster, Spandrel, and Spiral) were added to support IDS. The ModSAF VDD (CDRL AB04) discusses this in detail. Subsequent modifications have been made that include this functionality in the LAN interface for future applications in order to use standard versions of ModSAF.

3.2.9 Data Logger

The Data Logger is an ADST II asset that captures the network traffic and places the data packets on a disk or tape file. The Data Logger performs the following functions:

- a. Packet Recording - Receives packets from the DIS network, time stamps and then writes to a disk or tape.
- b. Packet Playback - Packets from a recorded exercise can be transmitted in real time or faster than real time. The Data Logger can also suspend playback (freeze time) and skip backward or forward to a designated point in time. The logger can be controlled directly from the keyboard or remotely from the Plan View Display (PVD). Playback is visible to any device on the network (PVD, Stealth Vehicle, a vehicle simulator, etc.).
- c. Copying or Converting - Files are copied to another file, which can be on the same or a different medium; and files from the older version of the Data Logger can be converted to a format compatible with the current version of the Data Logger.

For FPE III, two data loggers were employed to capture the exercise. The two data loggers were placed on the DIS net to capture all DIS PDUs for analysis. These two loggers used Sun IPX systems with 48 MB RAM, 1 GB Hard drive, utilizing the Sun OS 4.1.3 operating system. One data logger was designated as a back up and was not needed.

3.2.9.1 Audio/Video Capture

Fort Knox Television installed video and audio monitors to capture video from the sights and audio from the intercom systems in each manned simulator. Visual and audio data was recorded through the sights and intercom systems on every trial run for data collection. The data was reduced by the Research Assistants, plugged into the data logger for a time line, and then turned over to the representative from Test and Evaluation Command Coordination Office (TECO) for further analysis. Although, data analysis is not part of this report, the process is discussed in more detail in paragraph 4.3.

3.2.10 Time Stamper

The MWTB provided a Time Stamper which consisted of a video time code generator. This time code generator produced time data in days, and since 1 January, in hour/min/sec format. It also ran on an IBM-compatible Personal Computer (PC). The PC was programmed to read the video time code, convert the time data, and then generate a Time PDU which was then issued on the DIS network each second. This provided the real world clock time on the logged data to assist in subsequent analyses. This time was also used by PLGR to maintain their time.

3.2.11 Stealth System

The ADST II Stealth gives the Observer/Controller (O/C) personnel a "window" into the virtual battlefield allowing them to make covert observations of the action occurring during the scenario. In addition, through the use of the data logger, the Stealth gives observers and analysts an After Action Review(AAR) capability. The Stealth is a visual display platform that consists of a Plain View Display (PVD), various input devices, and three video displays that provide the operator with a panoramic, 3D view of the battlefield.

The Stealth permits the controller to fly around the virtual battlefield and view the simulation without interfering with the action. The features of the Stealth allow the observer to survey the virtual battlefield from a variety of different perspectives, including:

- a. Tethered View - Allows the user to attach unnoticed to any vehicle on the virtual battlefield. The Executive Officer was always tethered to his ModSAF vehicle.
- b. Mimic View - Places the user in any vehicle on the virtual battlefield and provides the same view as the vehicle commander.
- c. Orbit View - Allows the operator to remain attached to any vehicle on the virtual battlefield and to rotate 360° about that vehicle, while still maintaining the vehicle as a center point of view.
- d. Free Fly Mode - Permits independent 3-D movement anywhere in the virtual battlefield.

3.2.12 DIS LAN Network Configuration

A standard DIS LAN configuration was used with Ten Base T/AUI cable. Additionally, a dual port Sun Sparc Station was configured to enable the MWTB to FTP and have access to the Orlando corporate and simulation network.

3.3 Database and Scenario Development

The existing ADST II Fort Hood terrain database was used to support the experiment. The database was 50 Km by 50 Km and was used with sunshine and rain weather conditions.

A series of four test scenarios and one training scenario were developed to support FPE III. Each scenario contained four vignettes which depicted an Armor Company conducting a Deliberate Attack, Defense, and Movement to Contact operations. The scenarios included Operations Orders (OPORD), Fragmentary Orders (FRAGOs) and overlays to support the mission. The orders and overlays were developed by the Mounted Maneuver Battle Lab and Lockheed Martin Service Group (LMSG) MWTB personnel.

4. Conduct of The Experiment

4.1 Troop Training

In order to get the maximum benefit from the Pilot Test, a two week period of time was set aside for troop training to bring the soldiers up to a level of confidence on the systems prior to the Pilot Test. This troop training was conducted at the MWTB from September 30 to October 11, 1996. Subject Matter Expert's from TRW, MITRE and TARDEC provided classroom and hands-on training for Appliqué, E-BCIS and IDS. This training was complemented by MWTB familiarization and orientation on the actual operation of the simulators.

4.2 Pilot Test

The Pilot Test was conducted at the MWTB from October 15-18, 1996. During this week, the soldiers used the skills acquired in troop training to conduct tactical operations in a scenario specially designed to stress the systems and the soldier's skills. During this time special attention was given to technical anomalies that appeared. The anomalies that appeared during the Pilot Test involved the PLGR, Appliqué, and IDS.

The PLGR anomaly involved the update rate with Appliqué and an occasional hang-up of the system. This was solved by modifying the start up sequence, which required that the PLGR be started followed by a start-up of Appliqué, and then a restart of the PLGR. In addition, the PLGR automatic reset frequency was reduced from 600 to 120 seconds. These fixes allowed for better synchronization between the two systems which in turn provided for more accurate updates.

The Appliqué had an anomaly during the Pilot Test which would cause an occasional crash when sending Spot Reports. This problem was solved when it was discovered that Spot

Reports required a complete bumper number to be included in the address. Bumper number addresses were modified to meet the requirements. This corrected the problem.

IDS was successful in defending vehicles during the Pilot Test. However, several issues arose about the IDS defensive parameters such as the angle of defense, the percent of effectiveness, and the confusion involved when one's own vehicle weapons fire was detected. The recording of one's own vehicle weapons fire was removed, and missile detection was set for 360 degrees with time being allotted for the slew of the turret. Additionally, an off-line meeting was held to discuss the capabilities of the system for those who needed to become more familiar with the system. It was also noted during the Pilot Test that the computers running the IDS tones were not operating at optimum efficiency. This problem was traced to electrical interference within the building and a modification was made to the ground strap between the computers to correct the problem.

Following the Pilot Test, a week was set aside to fix discrepancies and conduct a TRR to discuss the problems, solutions, and status of the system. The TRR was held on October 24, from which LMC obtained permission to proceed with the experiment. Issues from the TRR are in Appendix A.

4.3 Experiment and Trial Runs

The trial runs for the experiment began October 28 and ended December 5, 1996. A total of 96 runs were conducted. The experimental unit was a Tank Company and a Scout Section. Manned entities were one Platoon with three-man crews in M1A2 simulators configured as M1A1s. The remainder of the Company was provided by ModSAF. An additional officer was provided by the troops supporting the experiment to play the role of the Company Commander and adjacent commanders to add realism. A Test Director was provided by TECO to support the trials. Trials were executed running the four scenarios with their four vignettes. One scenario with four vignettes consisted of one trial day, and each of the four vignettes were considered a trail run. The system configuration was altered in a random order to detect the incremental contribution of each system. The configurations for the experiment were (Baseline, Appliqué, Appliqué/E-BCIS, and Appliqué/E-BCIS/IDS). Table 2 defines the system configuration and scenario used in each trial.

January 29, 1997

Day/Trial	Configuration	Weather	Scenario
1/1-4	Baseline	Sunshine	#2
2/5-8	Baseline + Appliqué + E-BCIS + IDS	Sunshine	#1
3/9-12	Baseline + Appliqué + E-BCIS	Rain	#2
4/13-16	Baseline	Sunshine	#4
5/17-20	Baseline + Appliqué + E-BCIS	Rain	#1
6/21-24	Baseline + Appliqué + E-BCIS + IDS	Sunshine	#2
7/25-28	Baseline + Appliqué	Rain	#1
8/29-32	Baseline	Sunshine	#1
9/33-36	Baseline + Appliqué + E-BCIS	Sunshine	#4
10/37-40	Baseline + Appliqué + E-BCIS + IDS	Rain	#1
11/41-44	Baseline + Appliqué	Sunshine	#2
12/45-48	Baseline	Sunshine	#3
13/49-52	Baseline + Appliqué + E-BCIS	Sunshine	#1
14/53-56	Baseline	Rain	#2
15/57-60	Baseline + Appliqué	Sunshine	#1
16/61-64	Baseline + Appliqué + E-BCIS + IDS	Sunshine	#3
17/65-68	Baseline + Appliqué + E-BCIS	Sunshine	#2
18/69-72	Baseline + Appliqué + E-BCIS + IDS	Sunshine	#4
19/73-76	Baseline + Appliqué	Sunshine	#3
20/77-80	Baseline	Rain	#1
21/81-84	Baseline + Appliqué	Sunshine	#4
22/85-88	Baseline + Appliqué + E-BCIS + IDS	Rain	#2
23/89-92	Baseline + Appliqué + E-BCIS	Sunshine	#3
24/93-96	Baseline + Appliqué	Rain	#2

Table 2 Experiment Matrix

January 29, 1997

Week One was October 28 to November 1. Twenty trial runs in accordance with the matrix at Table 2 were programmed. Twenty trials were run and validated by the Test Director. One run was aborted after approximately five minutes when a simulator fell off the DIS net. However, on-site technicians did a reboot of the system and the exercise continued without any further incidents. All subcomponents of the system (E-BCIS, PLGR, IDS, IDS Tones, Appliqué, ModSAF, TIM/INC, and Appliqué LAN Interface) remained operational with no anomalies. There were no major issues during this week.

Week Two was originally scheduled for November 4-8 with twenty trial runs programmed. However, the week was reduced to November 4-7 with sixteen runs programmed due to a Fort Knox Training Holiday on November 8. Of the sixteen programmed runs, all were made and validated by the Test Director. On November 5, trouble developed with one of the TIM computers. This caused a delay in the start of the second run of the day to replace a bad hard drive. Engineers on-site corrected the problem, and the four projected runs were completed for the day. On November 6 and 7, an occasional communications loss developed but was not deemed harmful to the experiment. Data on the communication loss was captured and forwarded to MITRE for analysis. Additionally, on November 7, one simulator lost communications with the network at the end of the exercise. This, however, had no impact on the run. Totals at the end of Week Two were 36 runs programmed, completed, and validated out of the 96 required for completion of the experiment.

Week Three was November 12-15. This was Video Week and VIP Week, with November 14 set aside as VIP Day. During VIP Day, a separate hands-on demonstration was provided to allow the customers and their chain of command to experience complete operations of all the subcomponents of the system. This demonstration had no impact on the schedule for the week. Additionally, one day was used during the week to verify a fix to a technical issue that involved the start up sequence of the propagation capability of the TIM/INC. This verification was completed in parallel with the running of the scenarios, and was transparent to the exercise. It had no impact on the schedule. Sixteen trial runs were scheduled and run during the week. All sixteen trial runs were validated by the Test Director. Cumulative totals for the experiment were 52 trial runs programmed with 52 trial runs completed and validated by the Test Director. All subcomponents of the system were operational.

Week Four was November 18-22 with twenty trial runs programmed. Twenty-one trial runs were completed, and the programmed twenty trial runs were validated by the Test Director. The twenty-first, or extra, run was required on November 22 due to network problems in the MWTB. The network froze during one of the runs and the Test Director was not satisfied with the data received, therefore, an additional run was completed and validated. This extra run had no impact on the schedule. Cumulative totals for the experiment were 72 trial runs programmed with 72 trial runs completed and validated by the Test Director. All of the subcomponents of the system were operational for the week except for the incident when the network froze.

Open Week was 25-27 November (Thanksgiving Week) with no trial runs originally scheduled. However, a makeup day was held on November 25 to make up the four trials not completed due to the training holiday during Week Two (November 8). Additional trial runs

were made on November 26 to get ahead in the trial matrix. For this week, a total of eight trial runs were completed and validated by the Test Director. Cumulative totals for the experiment were 80 trial runs programmed with 80 trial runs completed and validated by the Test Director. All of the subcomponents of the system were operational for the week.

Week Five was December 2-6 was the last scheduled week in the 96 Trial Run Matrix. Twenty trial runs were originally programmed. Since November 26 was used as a day to get ahead in the matrix, this was changed to a total of sixteen trial runs. All sixteen runs were completed and validated by the Test Director. Cumulative totals for the experiment indicated that all 96 trial runs programmed were completed and validated by the Test Director.

Week Six was 9-13 December and scheduled as a make-up week to accommodate for any maintenance issues or verification issues that may have come up during the Trial Matrix runs. This week was not needed to complete the matrix. However, two days of excursion runs (E-BCIS Only) were allocated to PM Combat ID for the E-BCIS model., and three days were used to support demonstrations for MMBL and TARDEC on the IDS system.. These runs had no impact on the data analysis obtained from the ninety-six runs in the original matrix.

Analysis of the experiment data was conducted by TECO. TECO provided an officer and noncommissioned officer as the Test Director. The Test Director was present throughout the experiment and validated the trial runs on a daily basis. Data was collected on every run per the requirements in the Data Collection Plan established by the MMBL and TECO. This data was screened daily by MWTB personnel and then turned over to TECO for further analysis.

5. Observations and Lessons Learned

5.1 Mini-FAS

- Observation #1

The C2TD Mini-FAS was conducted in accordance with the Government's compressed timeline constraint. Therefore, the Mini-FAS Government and Contractor Evaluation Team could only provide true and accurate findings and recommendations with a 90% confidence level.

- Discussion #1

Due to the sensitivity of the proposed experiment execution timeline, the Government only allocated one calendar month (June) for execution. The original goal of the Mini-FAS was to accurately analyze several C2TD alternatives and provide a recommendation to the customers on the feasibility and the most value-added C2TD system for the experiment. In addition, the team had an implied task to gather information on the major simulation systems required to be integrated in the experiment as outlined in the Government's SOW. Since the Appliqué system was the customers' preference, the Mini-FAS was contractually structured so that the first C2TD system analyzed and evaluated was the Appliqué alternative. If the Appliqué system was deemed feasible to a certain level of confidence by all team members, the Mini-FAS SOW requirements were written with a severable clause that would allow the Mini-FAS

to cease a detailed evaluation of the other candidate C2TD systems. In order to meet schedule, all Mini-FAS trips were conducted back-to-back. Additionally, the Mini-FAS Report was produced in parallel with the proposal revision that was later submitted as a contract modification. The team brought laptop computers on their site visits with the intent of daily accomplishing a complete end-of-day capture of data, analysis, integration issues, and tasks. Due to the compressed time schedule, the technical complexity of the proposed simulation systems to be integrated in the experiment, and the collective experience level of the team members, they conducted a less than optimum analysis. For example, a somewhat inaccurate initial analysis of the hardware requirements later resulted in an identified need for additional PCMCIA cards and special drivers that were not available from SCO or the Compaq manufacturers.

The team discovered that we did not accurately estimate the integration effort for the PLGR. Once again, due to time constraints, the team experienced severe difficulty juggling the parallel tasks, such as analyzing the information obtain during the many visits to the Government and Contractor sites, accurately documenting the facts in a Mini-FAS Report, preparing and presenting a decision brief to the customers, and revising and staffing a contract modification proposal. Although the end report was fairly accurate, the compressed time caused some loss or misunderstandings of some data which was not documented completely until the end.

- Lesson Learned #1

Prepare and develop a detailed execution plan for the conduct of a Mini-FAS, regardless of the amount of time allocated for execution. Obviously there is a direct correlation between the length of time to execute and the quality of the Mini-FAS produced. Although the IPT process was implemented for this program, at times it was not completely accurate and timely in its application and execution. For example, we did not prepare and develop a detailed execution plan for the entire Mini-FAS development process. The plan should incorporate the following: (1) analyze the perceived requirements prior to the Mini-FAS, (2) analyze and document as you progress through the Mini-FAS, and (3) analyze and consolidate results prior to submission of the report. Although this was a Mini-Feasibility Analysis Study, there was not sufficient time to document and do as an accurate of analysis as was necessary.

5.2 Development and Integration

- Observation #1

SCO UNIX was difficult to integrate into the Compaq 5150 computers.

- Discussion #1

The installation of the operating systems was more difficult than originally analyzed and planned. The installation of SCO UNIX is a time consuming process that involves the installation of fifty-nine floppy disc on the system. This can be reduced with the use of a CD-ROM and docking station. At the start of the program, plans were to use the docking

January 29, 1997

station. However, due to a lack of parts from the vendor, the CD-ROM, driver, and docking station were not available until after integration started. We were forced to use a lengthy process which at first consumed approximately six hours per computer. Additionally, documentation from SCO and Compaq were not in complete agreement on compatibility. Compaq had modified their hardware after initial documentation was produced. This modification resulted in the unforeseen need for an additional third-party driver for the PCMCIA cards. Through extensive coordination with Compaq and several software houses, the drivers were obtained, but this was an unanticipated expense. This entire process caused readjustment and compression of some integration tasks which subsequently impacted on the integration timeline.

- Lesson Learned #1

During the Mini-FAS it was noted that a previous line of Compaq computers had been discontinued and replaced with newer models. Be very careful when making routine assumptions, and if at all possible, revalidate them more than once prior to execution. During our Mini-FAS, we made a routine assumption in regards to integrating Compaq computers. We assumed that a replacement equipment model of the same brand-name line would work as effectively and efficiently as its previous model did for the same applications. Additional coordination is required in the development of the Bill of Materials to ensure that vendor documentation on system compatibility between systems is up-to-date with the actual items being produced. Coordinate with the Government to allow a contingency in the Bill of Materials to accommodate for unknown hardware requirements. Allow enough time during a Mini-FAS and integration schedule to accomplish the tasks, and avoid planning according to schedule requirements.

- Observation #2

Inadequate personnel assets were originally programmed for integration at the MWTB.

- Discussion #2

Due to customer cost constraints, personnel assets were reduced and all overtime was taken out of the MWTB integration portion of the proposal during negotiations. As projected, we experienced some internal (i.e., complexity of integration) and external (i.e., late arrival of GFE) problems which significantly increased the original budgeted and allocated hours of MWTB support. During the requirements definition phase we conducted detailed coordination discussions to attempt to prevent a majority of these routine problems from arising. However, additional MWTB personnel were required during the initial set-up, additional fix phase, and the troop training phase of the experiment. Additionally, there is a requirement for supervision of OSF personnel by MWTB personnel while on-site due to security requirements at the MWTB. This security requirement causes an additional burden on MWTB personnel since they must be present during the entire integration process.

- Lesson Learned #2

The Integrated Product Team (IPT) process failed to adequately define the complexity of some integration tasks required at the MWTB and justify the hours identified and allocated in the original proposal. Subsequently, these hours were deleted. The IPT process should have anticipated some additional integration problems and supported the additional hours with a detailed justification. To further complicate this; the overall technical complexity of integrating all the major systems required a detailed Systems Engineering Integration Plan which we did not produce. We assigned individual tasks to specific individuals and did not give enough attention to parallel efforts. We were focused too much on ever changing GFE arrival dates and not task analysis or completion. The timely arrival of operational GFE could have made the integration much easier. Additionally, provisions should be made by the LMC Program Management Office to clear specific OSF personnel for off-hour access to the MWTB to allow more flexibility.

- Observation #3

CVSD Boards were extremely difficult to integrate into the FPE III simulators and we lacked a complete pre-integration test facility.

- Discussion #3

MITRE designed the boards and Modern Technologies produced the boards and associated wiring interfaces. Modern Technologies did not provide any updated documentation to MITRE. We discovered during the early stages of integration that the documentation from MITRE was old and not complete. Lack of close coordination, on-hand test tool equipment, and the transfer of documentation between MITRE and Modern Technologies prevented the CVSD boards from being properly tested at either location. All of these issues resulted in an extensive search for adequate documentation and an extended amount of time required to ensure that the CVSD boards were operational and could interface with the manned simulators. Due to the above problems encountered, we exceeded the original hours proposed and budgeted to execute this task.

- Lesson Learned #3

When multiple vendors are responsible for the design and production of a product, the agency responsible for integration must have a complete understanding of the roles and responsibilities that each vendor has in the design and production process. The integrator must ensure a complete documentation package is provided and, if possible, develop a one-stop integration testing facility.

- Observation #4

Failure to receive IDS tones and voice files in the correct format and numerous slips in the delivery date of the system increased the amount of support required to integrate this system.

- Discussion #4

There was some initial confusion between LMC, TARDEC, and Optimetrics on the requirements associated with this task, specifically on the exact format and content of the digitized voice files. This problem was further compounded with the late arrival of the IDS software, corrupted files, and the need to modify IDS Tones software several times after its original submission. Optimetrics did not have significant experience in the DIS protocol arena, therefore there was a flaw in the initial design of the IDS model. We eventually froze the software code and installed the system, but then discovered an additional problem with the electrical noise and interference. This noise was difficult to isolate, and was not completely corrected until a ground strap was developed and installed after the Test Readiness Review.

- Lesson Learned #4

This issue relates to the lack of an adequate plan to start the Mini-FAS which would have made the understanding of the tones requirement more clear and better understood by all agencies involved. Additionally, further analysis, including consideration of ground strap loop potentials and the use of shielded cables, should have been conducted during the Mini-FAS.

- Observation #5

The Functional Test Plan was adequate but not in as much detail as it should have been. The plan was not required in the Government SOW, and never discussed in the IPT process.

-Discussion #5

The Functional Test Plan was developed by a quick analysis of the basic requirements from the GFE subcomponents paragraphs in the Statement of Work. On the surface this seemed to be adequate. However, a more detailed analysis of the entire Statement of Work for all requirements and a better coordination effort with the GFE vendors on the capabilities of the specific models could have provided more insight to GFE capabilities and requirements. GFE suppliers should have been involved with LMC in the development of the Functional Test Plan. This would have resulted in a more detailed plan, and a more stressful Functional Test. As a result, more issues would have been captured in the Functional Test and fewer issues would have come up during the Pilot Test.

- Lesson Learned #5

Developing a Function Test Plan should be a specific task outlined in the proposal and allocated an appropriate amount of hours to perform. Additionally, it should be highlighted and annotated on the integration schedule and tracked as a separate task. The development of the plan should be a joint (Government and contractor) effort with the prime integration contractor taking the lead. Additionally, more time needs to be devoted by the contractor and GFE suppliers to analyze system requirements. GFE model suppliers should also be familiar with their model requirements and assist in development of the plan.

- Observation #6

The Test Readiness Review agenda should have been revised to incorporate more technical discussion on behalf of the customers.

- Discussion #6

The Test Readiness Review was designed as a decision brief based on a high level discussion of the systems subcomponents, technical issues and solutions that came from integration and testing. Even though the Test Readiness Review was a successful process, some confusion as to total system requirements did exist on behalf of the test personnel. Additional time should have been allocated to each of the GFE suppliers and customers to verify that requirements and capabilities have been met, and to provide a high level overview of their product.

- Lesson Learned #6

Design or structure the Test Readiness Review so that system requirements and customer needs are addressed as well as technical issues, solutions, and the state of readiness of the system. Identify and list all key players that need to attend this review. We should insist that this review be attended by both the customers management, technical engineers, and each Government agency's support contractor.

5.3 Experiment**- Observation #1**

There was not a complete understanding of all the requirements and objectives of the experiment by test personnel, contractor personnel, and the customers.

- Discussion #1

The experiment ran extremely smooth and on-schedule, and an excellent rapport was established between the customer, contractor, and test personnel. However, there were times when clear and complete understanding of all the requirements, priorities, and capabilities for each subcomponent of FPE III was lacking. We discovered during a discussion on propagation during week three (3) that the personnel who developed the test plan did not have a copy of the Government Statement of Work, and that the contractor and all the customers did not have a copy of the TECO/MMBL Test Plan. The test plan was developed from requirements in the Battle Lab Experiment Plan (BLEP), revised and dated August 15, 1996, after the proposal and ECP were submitted. Even though the Statement of Work and the Battle Lab Experiment Plan (BLEP) have a lot of common language, all players must be provided with all revisions to documentation on a consistent basis, and be involved in the planning or staffing of essential documents and requirements.

- Lesson Learned #1

It is vital that the Government agency who heads the experiment data collection and analysis properly invites all the key Government and contractor personnel to each internal meeting to disseminate the most accurate and up-to-date requirements and documentation. The

Government should ensure that all documentation is provided to all participants in the experiment and all key participants should be involved in the staffing of all critical documents such as the test plan. Additionally, all of the participants should be involved in all of the planning meetings (i.e., Data Collection Meetings, In Process Reviews and Training Meetings)

5.4 Overall

- Observation #1

Coordination and delivery of GFE items was more difficult than anticipated.

- Discussion #1

As a general rule, the arrival of GFE was late, it arrived in various states of operational condition, and documentation was not accurate or non-existent. This caused unnecessary delays and the shifting of integration tasks in the OSF. Ultimately, it deferred some integration tasks to the MWTB.

- Lesson Learned #1

Although flexibility is key in ADST II, better coordination needs to take place during the entire life of a program. GFE items must be clearly defined, delivery dates need to be adhered to, and a complete understanding must be reached with all players as to the exact nature of the GFE delivered item. The focus of the Technical Interchange Meetings (TIMs) seemed to be more oriented on LMC efforts, and GFE development status was always an add-on. It is recommended that in the future, all GFE developers/suppliers take a lead role in TIMs and be responsible for presentations on the status of their product. Otherwise, STRICOM must either convince the customer(s) to transfer responsibility and decision making authority to the entire experiment integrator, or hold the respective Government customer(s) totally responsible for adequately coordinating resources from other Government agencies. This should preferably be in writing prior to the end of the Requirements Definition phase.

- Observation #2

Detailed information on specifics of past efforts was difficult to obtain.

- Discussion #2

It was difficult to obtain information and become educated on past efforts. After reviewing past documentation, it was not clear who the current or past subject matter experts were.

- Lesson Learned #2

The configuration management library contained prior documentation and information, there was not an obvious, detailed, or all-encompassing list of Government and contractor SME POCs for that Delivery Order. Therefore, we relied entirely on the memory of certain individuals to identify previous POCs with which to communicate in regards to certain reusable systems and models. We recommend that this Final Report provide and attach a

POC list with telephone numbers. This list will allow future activities to have a starting point in doing their research.

- Observation #3

The OSF does not have the capability to read copies of tapes provided by off-site agencies.

- Discussion #3

During the Mini-FAS and during integration, software tapes were provided to the program from Ft Hood, Fort Knox, and industry. The purpose of these tapes was to have access to technical data and to assist in integration. In all cases the tapes provided could not be read by equipment in the OSF. This issue relates to tape density and compression. It is obvious that OSF equipment is not compatible with the equipment of many outside agencies. The only way data could be received was to use FTP. FTP efforts with large files takes many hours.

- Lesson Learned #3

Upgrade the OSF to a level that will allow transfer of data and computability with other agencies. Efforts are underway to upgrade equipment in the OSF to read low, medium and high compression tapes.

- Observation #4

Reliability of the M1A2 simulators at the MWTB is unsatisfactory.

- Discussion #4

It is a fact proven with historical data that the life of a M1A2 simulator is approximately one and a half hours. This appears to be a system limitation and an accepted way of doing business. As the reliability decreases, problems develop, and the systems must go through a long startup sequence. This issue impacts on scenario development, exercise duration, time spent on the simulators during integration and testing, and the length of the schedule required to accomplish the experiment. Even though the ninety-six trial runs had minimal problems during the actual running of the scenarios, a major effort was required to start the simulators at the start of every day and between runs. The scenarios were designed with this limitation in mind, and most exercises ended just prior to problems occurring. To prevent problems from appearing in the next run, a lengthy reboot effort took place between each run and an excessive amount of time was wasted between runs. Excessive/wasted time with troops sitting around between runs becomes a common practice. A more reliable system would decrease the time to actually conduct an experiment which would save cost, decrease troop support time, and improve the troop's confidence in the system. This would create better performance during the experiment. During the twenty-four days of trial runs, seventy-two incidents occurred with the simulators. Simulator reliability status is at Appendix B.

- Lesson Learned #4

Resources should be allocated through the CDF Upgrades DO, as well as using DO cost savings, to study and improve the reliability of the simulators.

- Observation #5

Time and effort for documentation for an experiment of this complexity was significantly more than proposed.

- Discussion #5

We significantly under estimated the elaborate detail and quantity of documentation that has to either be revised, modified, or newly developed for configuration management purposes. The Cold Start Manual and Version Description Documents were perceived as minimal effort. The technical complexity of the experiment was enormous considering all the hardware and software components that were integrated. The Cold Start Manual will be lengthy, the Version Description Document has numerous separate sections (ModSAF, PLGR, IDS Tones, and Appliqué Interface) totaling approximately seventy pages. The Final Report and Hardware Design and Configuration Document (HDCD) will be very detailed and newly prepared. The Government has a requirement for the HDCD to be very complex, with each subcomponent to be separately drawn down to the cable level. Additionally, we are providing an Interface Control Document which is not required but necessary due to the complexity of the experiment. Furthermore, at the time of proposal submission, the internal process for templates and procedures was not established. The established procedures now are more detailed than anticipated.

- Lesson Learned #5

This problem appears to be well along the way to being solved. LMC Program Management and STRICOM efforts have established formats and examples of the above mentioned documents in template format. This now allows the engineers to write an initial version of the documents through out the program, which would then only requires updates as you finish of the program. Additionally, a better understanding of the documentation requirements in the Requirement Definition phase by the engineering staff, management staff and the customer(s) would greatly reduce the time associated with this task.

6. Conclusion

The Force Protection Experiment III (FPE III) was a fast paced and technically complex effort that achieved its goal. The successful integration of multiple GFE software models into the MWTB hardware provided the desired synthetic environment for the customers. This environment allowed them to analyze and evaluate the resulting data to assist in developing better force protection, increased survivability, and enhanced command and control procedures. Combined, these enhancements will better preserve the force in combat operations.

The experiment also provided valuable information to TRW, MITRE and PM Appliqué on the performance and integration of Appliqué, the CVSD Boards, and the TIM/INC, as well as insight into issues for Force XXI.

7. Points of Contact

ADST II FPE III Team

E.G. Fish	Project Director	407-306-4456
G.W.J. Kenney, Jr	Systems Engineer	407-306-4376
Kevin Mueller	ModSAF, SW Lead	407-306-4455
Mike Blocker	Hardware Engineer	407-306-4225
James Page III	ModSAF mods	407-306-1900
James McCulley	Linux & SCO Unix	407-306-4613
Cristl Weckenmann	S/W - TIM / INC / PLGR	407-306-5637
Bob Meyer	PLGR, SW mods	407-306-4139
Don Appler	MWTB Site Manager	502-942-1092
Eberhard Kieslich	MWTB Lead Engineer	502-942-1092
Paul Monday	MWTB Data Collection	502-942-1092
Dan Schultz	MWTB Battlemaster	502-942-1092
Charles West	MWTB Asst Battlemaster	502-942-1092
Don DeBord	MWTB Asst Battlemaster	502-942-1092
Tim Voss	MWTB SW Technican	502-942-1092
Rob Smith	MWTB Engr Technican	502-942-1092
Paul Monday	MWTB SW Integration	502-942-1092
Ron Flackler	MWTB Image Generator	502-942-1092
Tom Van Lear	MWTB Technican	502-942-1092

STRICOM

Major Chris Bailey	Project Director	407-384-3671
Chris Metevier	Project Engineer	407-384-3865

Customer Points of Contact

Joe Jarboe	MMBL, Ft Knox	502-624-8451
Ron Kacsmar	PM Combat ID	908-427-2234
Ed Maluszcak	E-BCIS Proj Lead, Ft. Monmouth	908-427-5270
Stephanie Habledank	PM Combat ID	908-427-5038
Bryan Beaudoin	TARDEC	810-574-6693

TRW (Appliqué Software)

Joe Provenzano	TRW, Deputy PM	310-764-3510
Mr. George Gallagher	APM Training, ILS for TRW	310-764-3054

Compaq (Appliqué Hardware)

Jess Long	SCO and Model 5150 SME	713-927-1276
Tech Support		800-652-6672

January 29, 1997

Creative Labs (Sound Blaster Cards)

Advanced Users		405-742-6600, x 6655
Pwilliams@creaf.com		405-742-2327

PM Appliqué Ft. Monmouth

LTC Van Fossen	Program Manager	908-427-2966
JoJo Clemente	SW Engineer	908-427-3121
David Egli	Computer Scientist	908-427-2718
Paul Lucyk	Technical Management	908-427-2786
Frank Nissen	Technical Management	908-427-2780

CECOM Ft. Monmouth

Bill Sudnikovich	Ft. Monmouth, NJ	908-427-4093
------------------	------------------	--------------

MITRE New Jersey

Ed McCarthy	MITRE	908-389-5685
Jon McConnell	MITRE TIM/INC-PM	908-389-5670
Jeffery Vogel	MITRE TIM/INC-SW	908-389-5670
Mark Riehl	MITRE TIM/INC-SW	908-389-6752
Gus Diaz	MITRE TIM/INC-Sys Engr	908-389-5670
Jerry Michael	MITRE-Sys Engr	908-389-6743

LynnSoft, Inc., 305 Mountain Drive Suite E, Destin FL 32541 (SCO Drivers)

Brenda Follis	Sales	904-650-2266
Mr Ott	Manager	904-650-2266

<u>Quatech, Akron, Ohio - DSP-100, (Dual Channel RS 232 PCMCIA)</u>		
Kevin Kline	Lead Engineer	216-434-3154
		800-553-1170
		330-434-3154

SAIC San Diego (V2 Appliqué Hardware)

Rollie Brubaker		619-552-5481
-----------------	--	--------------

SCO

Craig Lockwood	Sales	408-439-4158
		800-386-2172
Paul Herford	Sales	408-427-7583
Dave Rankin	SCO Restin VA - SAIC	703-715-8734

January 29, 1997

OTHER PERSONNEL

Jorge Cadiz, GDLS	ADST I, EXFOR Appliqué DO Manager	470-380-5500
Robert Fraser, Illusion Ft. Hood	ADST I, EXFOR Training Site, EXFOR	407-359-1232 817-287-5282 817-288-4098
Steve Gilbertson, TRADOC MAJ Kirkpatrick, TECO Ft Knox Ken Mellin, PM Cbt ID Dr Parrish, White Sands Shin Shey, MIT Lincoln Labs CPT Joe Taylor, Ft Knox Rich Mezan, AMSAA	BCIS Test Director E-BCIS EXFOR Janus Constructive Modeling Hit Avoidance Validation & Verification	804-728-5863 502-624-2710 703-578-3765 505-678-4949 617-981-0705 502-624-2453 410-278-2091

MITRE, Bedford, Mass

Ron Williams	E-BCIS Lead Engineer	617-271-3939
Stan Manoski	E-BCIS Engineer	908-389-6772
Chris Nissen	E-BCIS Engineer	617-271-3370
Jeffrey Blanchard	E-BCIS Engineer	617-271-7138
Beth Gallivan	E-BCIS SW Engineer	617-271-5457
Mark Riehl	E-BCIS SW Engineer	908-544-8863

OMI, Ann Arbor, MI

Fred Smith	Vice President	313-973-1249
William Miller	Vice President	313-973-1177
Allan Dunston	IDS SW Engineer	313-973-1249

Acronym List

AAR	After Action Review
ADST	Advanced Distributed Simulation Technology
BCIS	Battlefield Combat Identification System
BFV	Bradley Fighting Vehicle
BLEP	Battle Lab Experiment Plan
BLUFOR	Blue Forces
C2	Command and Control
C2TD	Command and Control Tactical Display
CDF	Core DIS Facility
CDRL	Contract Data Requirements List
CECOM	Communications & Electronics Command
CIG	Computer Image Generator
CVSD	Continuous Variable Slope Delta
DDL	Digital Data Link
DO	Delivery Order
DIS	Distributed Interactive Simulation
E-BCIS	Enhanced Battlefield Combat Identification System
EPLRS	Enhanced Position Location Reporting System
EXFOR	Experimental Force
FPE III	Force Protection Experiment III
FRAGO	Fragmentary Order
FTP	File Transfer Protocol
GFE	Government Furnished Equipment
GPS	Global Positioning System
HDCD	Hardware Design Configuration and Document
H/W	Hardware

IDS	Integrated Defense System
INC	Internet Controller
I/O	Input/Output
LAN	Local Area Network
LMC	Lockheed Martin Corporation
LMSG	Lockheed Martin Service Group
LRF	Laser Range Finder
M1Ax	Abrams Main Battle Tank ("x" = variant)
MBT	Main Battle Tank
Mini-FAS	Mini Feasibility Analysis Study
ModSAF	Modular Semi-Automated Forces
MMBL	Mounted Maneuver Battle Lab
MMW	Millimeter-Wave
MWTB	Mounted Warfare Test Bed
OC	Observer Controller
OPFOR	Opposing Forces
OPORD	Operations Order
OMI	Optimetrics, Inc
OS	Operating System
OSF	Operational Support Facility
PC	Personnel Computer
PDU	Protocol Data Unit
PLGR	Precision Lightweight GPS Receiver
PM	Program Manager
POC	Point of Contact
PPP	Point-To-Point Protocol
PVD	Plan View Display
RAM	Random Access Memory
RIU	Radio Interface Unit

RP	Role Player
SAF	Semi-Automated Forces
SCO	Santa Cruz Operating System
SEIT	Systems Engineering Integration Team
SGI	Silicon Graphics Industries
SIMNET	Simulation Network
SINGARS	Single Channel Ground and Airborne Radio System
SME	Subject Matter Expert
SOW	Statement of Work
SRE	SINGARS Radio Emulator
SRM	SINGARS Radio Model
STRICOM	(US Army) Simulation Training and Instrumentation Command
TACOM	Tank Automotive and Armaments Command
TARDEC	Tank Automotive and Armaments Command Research Development and Engineering Center
TC	Tank Commander
TECO	Test and Evaluation Coordination Office
TF	Task Force
TIM	Tactical Internet Model
TIM	Technical Interchange Meeting
TRR	Test Readiness Review
TTP	Tactics, Techniques, and Procedures
UDP	User Data Protocol
VDD	Version Description Document
VMF	Variable Message Format
VIP	Very Important Person

Appendix A - Test Readiness Review Issues

The Test Readiness Review was held at the MWTB on October 24, 1996 with all the customers present as well as representation from OPTEC, AMSAA, MITRE, Optimetrics, and PM Appliqué. The following issues were discussed by subsystem:

1. E-BCIS: The E-BCIS model was reported as operational. Discussion took place with regard to the degraded laser range finder using three inches of rain per hour in the model. The discussion did not question the validity of the model, but was of the nature to bring the audience up to date on the parameters. The effect of the degraded laser condition was that a "Friend in Sector" indication would be given when normally a "Friend" indication would occur, since there would be no laser range to compare to the BCIS mmW range (BCIS could not verify that the targeted vehicle was indeed the "Friend" responding). There was no effect on the fire control system with this modification. Additionally, discussion took place on capabilities of E-BCIS, and it was noted that not all of the players were aware that the E-BCIS had a minimum range of 150 meters.
2. PLGR: The PLGR model was reported as operational, and discussions took place on the fixes to the start up sequence, reset time, and synchronization with Appliqué that had taken place over the preceding week. It was noted that the PLGR had a lengthy startup process that impacted time available during the day for running the experiment. With knowledge of position reporting being timely and accurate through the Appliqué LAN Interface, it was agreed by all the customers to replace the PLGR with the Appliqué LAN Interface position reporting capability. This seemed to be the logical approach since it was projected to save over an hour a day and allocate more time for actual experiment runs.
3. IDS: The IDS model was reported as operational. Discussion took place on the following issues: that reporting of own main gun fire had been removed; that missile defense was now set for 360 degrees; and that there was a need to have a follow up session on IDS capabilities to educate the participants on the system. Additional discussion took place on IDS tones, which remained an open issue. This issue was closed on the first day of the experiment when a modification to the ground strap was installed on the tones computer to reduce facility electrical interference. This allowed the computers to run in an optimum state.
4. Appliqué: The Appliqué model was reported as operational. However, discussion did take place on the Appliqué screen update rate and the fact that it could be changed from 20 seconds to 10 seconds. It was decided at the TRR to leave the update rate at 20 seconds since the troops had already trained on the system and that there might be an impact on data collection, Appliqué data storage requirements, and Appliqué Interface timing. Trackball sensitivity was discussed, and was an open item at the end of the TRR. A change to the trackball sensitivity was made, approved by the customer, and installed on the first day of the experiment.
5. ModSAF: ModSAF was reported as operational. No issues were discussed. However, it was noted that a list of nonstandard ModSAF parameters were required for documentation.
6. TIM/INC: These models were reported as operational and no issues were discussed.

7. Appliqué Interface: It was noted that the Appliqué Interface would replace the PLGR on position reporting and that the interface was supposed to supply OPFOR position reports to Appliqué from the IDS.

Appendix B - M1A2 Simulator Reliability Issues

The Force Protection Experiment III was conducted over a period of twenty four-days (days of actual exercise runs). During this twenty-four day period, the Battlemaster and staff at the MWTB experienced seventy-two problems with the on-site simulators.

Simulator Equipment Issues are:

- 15 incidents of host computer lock up
- 21 incidents of sound reset due to the loss of host aural cues
- 2 incidents of IDC reset where the simulator IDC board loses inputs through the serial line
- 6 incidents where the host fell off the network
- 11 incidents of call back error between the host and the IG
- 16 graphic error incidents with the IG
- 1 incident of CIG lockup