

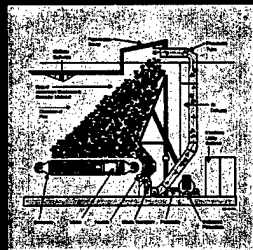

U.S. Army
Environmental
Center

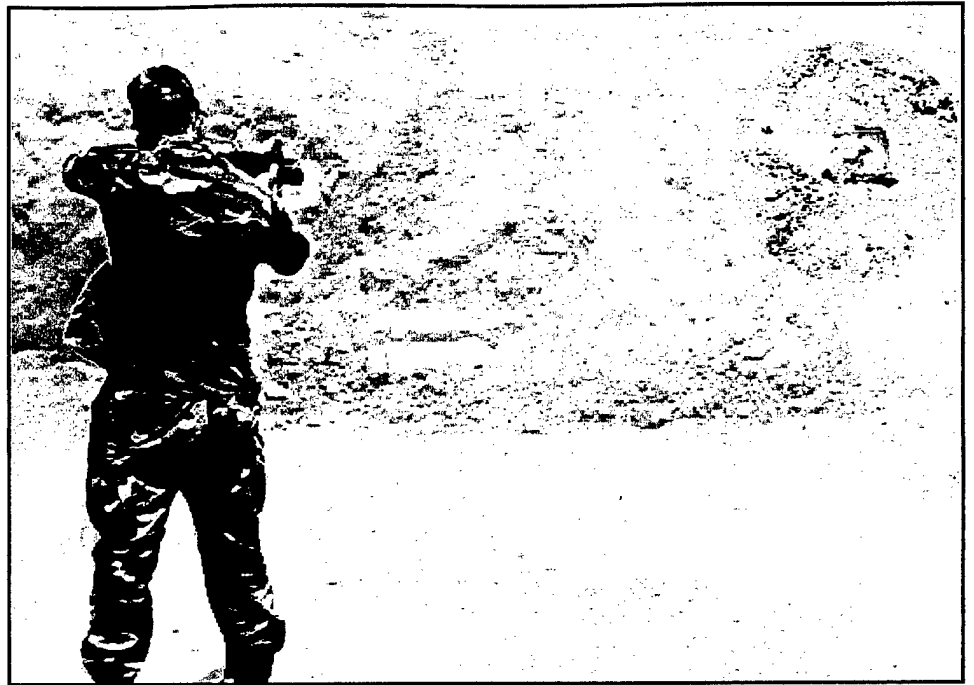

19970605 118



BULLET TRAP USER'S GUIDE

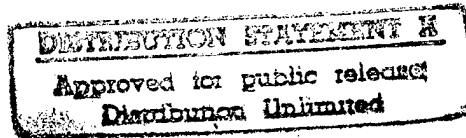

Report No. SFIM-AEC-ET-CR96201

Sponsored by:
The Army Environmental Center &
The Army Training Support Center

Prepared for:
Defense Evaluation Support Activity
2251 Wyoming Blvd. S.E.
Contract No. DW398AW95

DTIC QUALITY INSPECTED 4

Prepared by:
TRW - Systems Integration Group
One Federal Systems Park Drive
Fairfax, Virginia 22033

Table of Contents

Section	Page
Executive Summary.....	1
Introduction.....	3
Purpose.....	3
Background.....	3
Scope.....	3
Methodology.....	5
The Ranges for which Traps were Analyzed.....	6
Trap Types.....	9
Trap Descriptions.....	11
Friction.....	11
Deceleration.....	22
Impact.....	25
Analysis Summary.....	27
25 Meter Range.....	32
Automate Field Fire Range.....	32
Automated Record Fire Range.....	33
Combat Pistol Qualification Course.....	33
Estimating Target Receive Rates.....	35
Installation Considerations.....	37
Estimating Capital and Life Cycle Costs.....	41
Trap Placement Strategies.....	43
Discussions with Manufacturers.....	44
Maintaining your Trap.....	46
Conclusions.....	47

On the cover



Soldier firing on an experimental SACON block. (Photograph provided by the U.S. Army Corps of Engineers Waterways Experiment Station)

Disclaimer:

This Bullet Trap User's Guide represents our best effort to assist training range management professionals through the process of employing bullet traps on outdoor small arms ranges. Inclusion of a bullet trap in this report does not constitute an endorsement or approval of use of that trap. The views, opinions, and findings contained in this report should not be construed as an official Department of the Army position, policy, or decision, unless so designated by other documentation. This report may not be cited for purposes of an advertisement.

	<u>Section</u>	<u>Page</u>
List of Tables	Table 1 - Feasible Bullet Traps.....	9
	Table 2 - Bullet Trap Evaluation by Individual Criteria.....	28
	Table 3 - Bullet Trap Evaluation Which Distinguish the Four Range Types.....	29
List of Figures	Figure 1 - 25 Meter Range.....	6
	Figure 2 - Automated Field Fire Range.....	7
	Figure 3 - Automated Record Fire Range.....	7
	Figure 4 - Combat Pistol Qualification Course.....	8
	Burleburger Schaumstoffwerk - REGUPOL.....	11
	Capito & Assenmacher - Granular Trap.....	12
	Caswell - Gran Trap.....	13
	Caswell - Lamella.....	14
	COTS - Logs or Railroad Ties.....	15
	COTS - Rubber Blocks.....	16
	COTS - Tires.....	17
	COTS - Wax/Plastic Blocks.....	18
	Range Masters - TEC.....	19
	Waterways Experiment Station - SACON.....	20
	Societa FRA.SA - Elastomeric Granular Screen.....	21
	Action Target - Total Containment Trap (TCT).....	22
	Savage Range Systems - Passive Bullet Trap OM96.....	23
	Shooting Ranges International - R493.....	24
	Action Target Thunder Ranch.....	25

Executive Summary



This Bullet Trap User's Guide provides range management professionals with direction for choosing, installing, and maintaining bullet traps to solve metal migration, erosion, or safety problems on their outdoor small arms ranges. Bullet traps provide environmental benefits by reducing the accumulation of lead, copper, and other metal constituents in range soils. These metals in soils have the potential to migrate to surface or groundwater. In addition to containing metals, range personnel may use bullet traps to prevent accelerated erosion caused by repeated bullet impacts into range soils, which physically removes soil and vegetation. Bullet traps may also alleviate small arms range safety concerns by preventing ricochets or stray rounds from leaving the immediate range area.

Although this guide summarizes the bullet traps which work for various range types, this document focuses on the implementation of bullet traps, after you have narrowed the decision to a few traps. Many types of bullet traps exist. Of the bullet traps available, those made from Commercial-Off-The-Shelf local materials (wood, tires, plastic, wax) have the virtue of simplicity, ease of construction, and relatively low capital cost, but lack long term durability (<10,000 rounds) and impose a "disposal burden" on the range manager. Disassembly and disposal of these materials may take the range out of service for many days and cost a great deal.

Of the traps available from commercial vendors, three types exist: friction, deceleration, and impact. Friction traps use material (rubber or Shock Absorbing Concrete (SACON)) in blocks, granular, or venetian blind designs. They slow and absorb bullets, and some channel bullets into a receptacle for easy recycling. Deceleration traps use steel deflection plates to direct bullets into a helical chamber where they spin until they lose energy and drop into a collection chamber for easy recycling. Only one type of impact trap is feasible for outdoor applications (contains bullets fragments); it uses a steel backed wooden box with an elastic front and captures only handgun sized ammunition.

To choose the best trap for your individual range, you first estimate the potential annual target receive rates (number of rounds per target per year). This will allow you to estimate the days per year of major maintenance, which translates into days per year of range down time. Frictional traps require replacement/ refurbishment every 10,000 - 50,000 rounds, whereas deceleration traps require replacement/refurbishment every 200,000 - 500,000 rounds.

Second, consider bullet trap installation requirements including: site preparation, space and structural requirements, utility requirements, overhead protection, and the trap's compatibility with tracer rounds. For example, you may have a 25 meter range with high annual target receive rates (200,000 rounds/ year) but lack the land or space to construct a concrete base required for deceleration traps.

Third, consider not only the capital investment for these traps, but the lifecycle cost. For unrecyclable frictional traps (all except for SACON), you will generally have to dispose of the used impacted material as a hazardous waste. Information to date suggests that this material does not pass the Toxicity Characteristic Leaching Procedure (TCLP) test. Material disposal costs between 300 and 450 dollars per ton. The maintenance rate, together with a volume of material per target will yield an annual disposal cost.

Fourth, if you now have only one or two trap options remaining after considering range operations, space/ structural requirements, and cost, then consider whether the firer can sight down range targets given various trap placement strategies. Choose your trap placement strategies according to the bullet trajectories, ability to sight down range targets, and existing "beaten zones" (bullet impact areas with removed vegetation).

Fifth, consider phoning the manufacturer and discussing the detailed manufacturing and installation arrangements as well as the warrantee(s) associated with the trap(s) you want to purchase. The purchase price may depend on the number of traps and the maintenance agreement. Consider negotiating an extended warrantee and maintenance agreement. This may allow you to better estimate the costs (time and money) associated with employing bullet traps on your range.

Lastly, consider bullet trap maintenance after installation. Bullet trap maintenance includes: arranging for bullet recycling, rotating sections for modular traps, arranging for regular maintenance, and removing / replacing / disposing of unrecyclable portions of the trap.

Introduction

Purpose

This Bullet Trap User's Guide provides preliminary direction and guidance for range managers in the process of choosing, installing, and maintaining bullet traps on their small arms range. The U. S. Army Environmental Center (AEC) in cooperation with the Army Training Support Center (ATSC) sponsors this guide, written by TRW, as one of several tools for small arms range managers. This guide serves those range managers who may need bullet traps to mitigate potential lead migration, reduce future land rehabilitation, or alleviate safety concerns (ricochets) associated with firing bullets on small arms ranges.

Background

The Department of Defense operates more than 2000 small arms ranges throughout the United States. Individual firing ranges expend millions of rounds annually. Lead, Copper, Zinc, and Antimony may accumulate in range soils due to range use. Bullet traps can potentially mitigate lead accumulation, migration, and reduce the need for extensive land rehabilitation (AEC report number SFIM-AEC-ET-CR96195). Repeated bullet impact around and near target areas creates beaten zones where bullets splatter soil material. These incised beaten zones lack vegetation, promote soil erosion, give away the target location, and detract from range realism. This accelerated erosion may increase the need for land rehabilitation.

In addition to minimizing land rehabilitation and preventing pollution, discussions with range managers indicate that for installations with either very hard soil (e.g. frozen) or soils which build-up enough lead in the beaten zones to create a ricochet hazard, bullet traps may mitigate safety concerns.

Scope

This guide focuses on bullet trap implementation rather than the feasibility analysis for your range. A separate report, entitled "Bullet Trap Feasibility Assessment," looks at the broadest spectrum of bullet traps and provides an analysis of which traps appear feasible on four outdoor ranges: 25 Meter, Automated Field Fire-AFF, Automated Record Fire-ARF, and Combat Pistol Qualification Course-CPQC (AEC report number SFIM-AEC-ET-CR96195). The material presented here summarizes those results by first describing and displaying the previously assessed feasible bullet traps and then listing the traps which apply to the four ranges. Although these two reports provide guidance they do not guarantee the performance of any bullet trap, or provide comprehensive answers to a specific set of problems on an individual range.

Bullet Trap User's Guide



For additional help regarding bullet traps and up to date information on recent bullet trap testing you may contact the Army Environmental Center on their electronic mail (t2hotline@aec.apgea.army.mil), on their telephone hotline (1-800-USA-3845), or look for information on their Web Site (<http://aec-www.apgea.army.mil:8080/>).

This report is organized to first show the feasible traps and then take you through the process of implementing the right trap for your range. Choosing a trap and implementing it on your range depends on your personal preferences (how you weight the specific evaluation criteria) as well as the physical layout and requirements of your range.

Methodology

The research team used interviews and site visits as the primary means for identifying commercially available bullet traps (as of June 1990; AEC report SFIM-AEC-ET-96005), developing evaluation criteria, assessing bullet trap feasibility, and establishing factors important to installing and maintaining bullet traps. The research team used many electronic databases and spoke with various international sources to cover all possible bullet traps and choose appropriate evaluation criteria (details may be found in AEC report SFIM-AEC-ET-CR96195). Discussions with four bullet trap manufacturers and many range managers form the basis for the text associated with trap installation and maintenance, the primary focus of this guide.

The team visited the following bullet trap manufacturers: 1) Caswell International, in Minneapolis, Minnesota; 2) Range Masters, Inc., in Le Center, Minnesota; 3) Action Target, in Provo, Utah; and 4) Shooting Ranges International, in Las Vegas, Nevada. After these discussions, the team visited installations using outdoor bullet traps.

The team visited Fort Drum, New York, which uses a venetian blind type friction trap on a 25 meter range; Quantico Marine Corps Base, Virginia, which was testing one granular rubber friction trap at a single firing point on a 25 meter range; Fort Knox, Kentucky, which uses a mound of wooden logs on a Field Fire range instead of a berm; Thunder Ranch, New Mexico, (commercial firearms training school) which has many portable wooden/elastic steel-backed boxes used in an indoor shooting house and several outdoor ranges; and Tinker AFB which has a fixed distance range with steel deceleration traps.

The research team also visited ranges without traps and met with range managers to discuss factors important to installing and maintaining bullet traps on outdoor ranges. The following eight additional installations were visited: Fort Benning (Georgia), Fort Eustis (Virginia), Fort Hood (Texas), Fort Jackson (S. Carolina), Fort Leonard Wood (Missouri), Fort Pickett (Virginia), Fort Rucker (Alabama), and Fort Sill (Oklahoma).

The Ranges for which Traps were Analyzed

The Bullet Trap Feasibility Assessment (AEC report number SFIM-AEC-ET-CR96195) analyzed bullet traps across four range types, which were chosen based on range use (e.g. known distance versus pop-up target), types of weapons used, and variety of range layouts (distances between targets). Figures 1 through 4 illustrate the layout of the four range types: 25 Meter, Automated Field Fire, Automated Record Fire, and Combat Pistol Qualification Course. The figure captions describe the range uses for those unfamiliar with small arms ranges.

Figure 1. 25 Meter Range

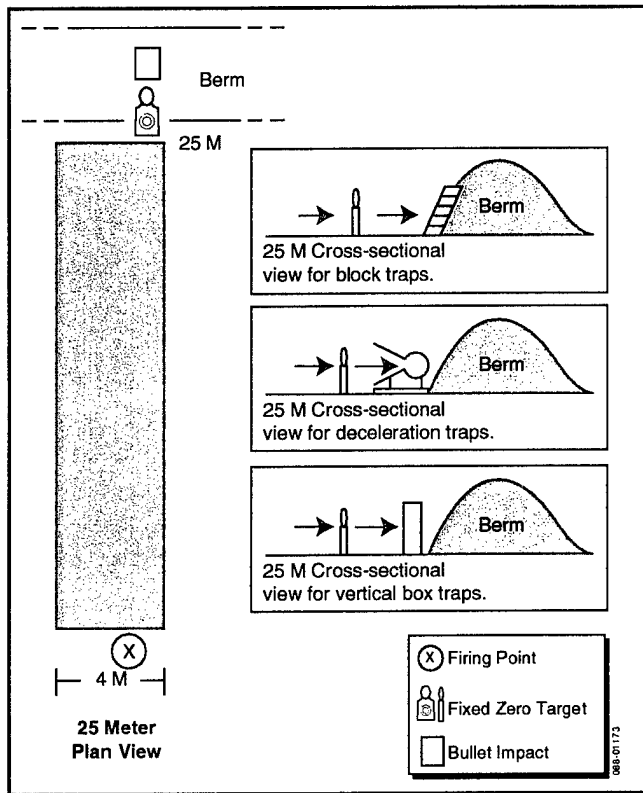

This figure shows one firing lane on a 25 Meter Range (plan view) and three cross sectional views showing possible bullet trap configurations. The 25m range generally consists of 110 firing lanes, each 4 meters wide. This range experiences approximately 9 - 24 rounds per firer. The firer shoots at a single, fixed and known distance target. Neither masking nor camouflaging affects the choice of bullet trap.

Figure 2. Automated Field Fire Range

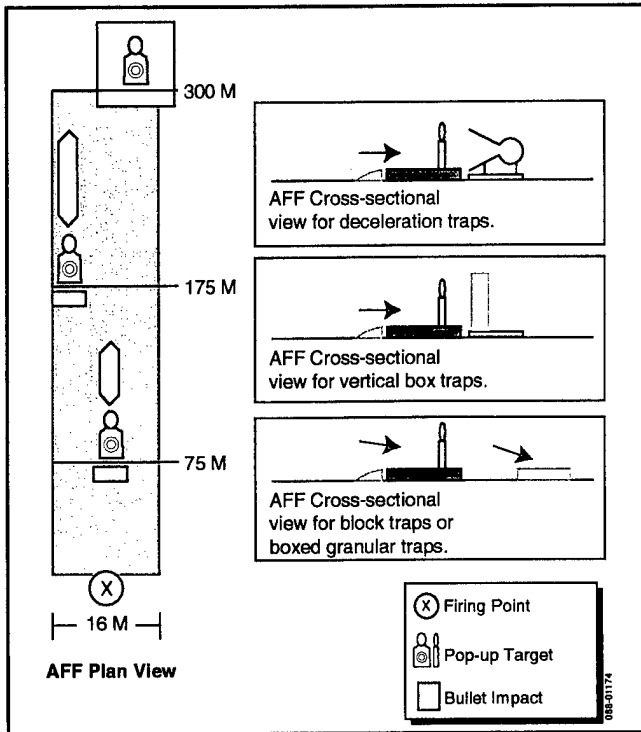

This figure shows one firing lane on an Automated Field Fire Range (plan view) and three cross sectional views showing possible bullet trap configurations. The Automated Field Fire Range has 32 firing lanes, each 16 meters wide, with known pop-up targets at 75, 175, and 300 meters. The soldier generally fires 40 rounds: 10 at the 75 meter target, 20 at the 175 meter target, and 10 at the 300 meter target. The target locations are spaced far enough apart down-range that neither masking or camouflaging affects the choice of bullet traps.

Figure 3. Automated Record Fire Range

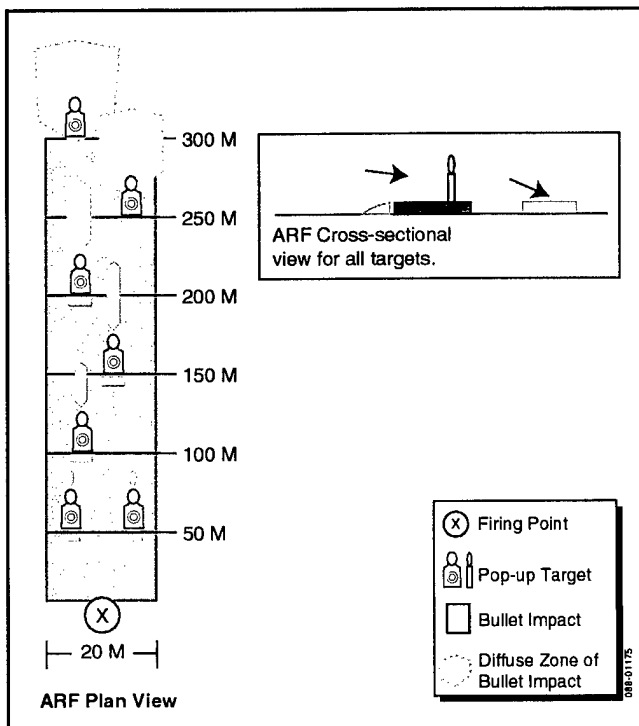

This figure shows one firing lane on an Automated Record Fire Range (plane view) and a cross sectional view of one target showing either granular box trap or block trap nearly flush with the ground. This range generally has 16 firing lanes with 7 pop-up targets per lane at distances of 50, 100, 150, 200, 250, and 300 meters. The soldier generally fires 40 rounds. Given that target locations must remain unknown on this range and the close proximity of the targets, both masking and camouflage will be major factors affecting the choice of bullet traps.

Figure 4. Combat Pistol Qualification Course

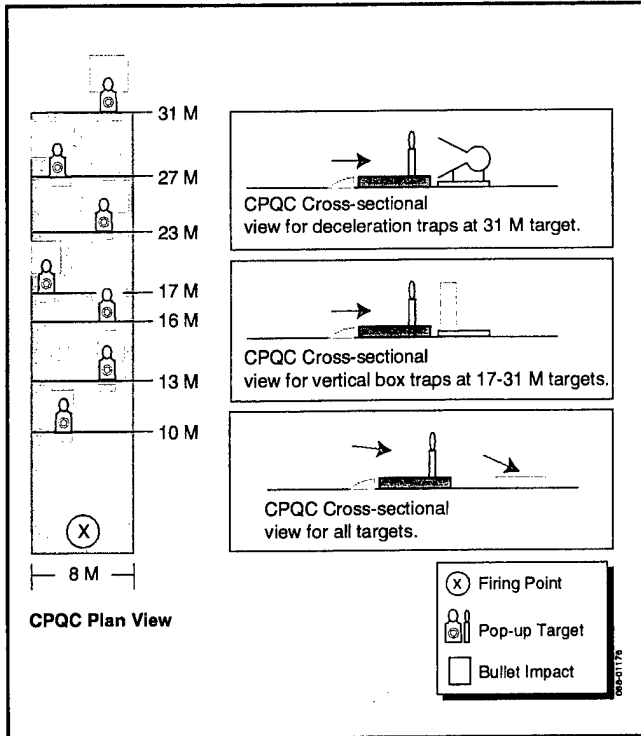

This figure shows one firing lane on a Combat Pistol Qualification Course (plan view) and three cross sectional views showing possible bullet trap configurations for various targets. The Combat Pistol Qualification Course has 15 lanes, each 8 meters wide, with 7 pop-up targets at 10, 13, 16, 17, 23, 27, and 31 meters. Although the locations are known, target masking will affect the choice of bullet traps for most targets on this range. This range only handles handgun ammunition up to .45 caliber.

Trap Types

Bullet traps utilize three different mechanisms for stopping bullets:

- 1) friction,
- 2) deceleration, and
- 3) impact.

These stopping mechanisms form convenient categories for bullet traps because this also places them into groups with similar layouts. Friction traps use a medium (such as wood, rubber, soil, plastic, or Shock Absorbing Concrete (SACON)) to slow and eventually stop the bullet. Deceleration traps use angled steel plates to deflect bullets into a helical chamber where bullets spin until they lose velocity and drop into a collection chamber. Impact traps stop a bullet at its initial contact with the trap material, which is a steel-backed wooden box.

You may construct friction traps from commercial-off-the-shelf (COTS) materials (tires, railroad ties, wax logs, and rubber blocks) or purchase selected varieties from a manufacturer. While these friction traps may provide some pollution prevention improvement, most require eventual disposal of the trap material (rubber, wax, or wood) as a hazardous waste.

Table 1 lists the names of all feasible bullet traps (AEC report number SFIM-AEC-ET-CR96195) for all three categories of traps, although not all traps apply to all ranges, and traps may be feasible only at certain target distances on a range. The section entitled "Analysis Summary" describes the specifics of trap applications across the four range types. Table 1 provides a quick summary of the traps, with the manufacturers' name followed by the trap name. For manufacturer addresses and phone numbers, see Appendix B.

Table 1 - Feasible Bullet Traps

FRICION
Burleburger Schaumstoffwerk - REGUPOL
Capito & Assenmacher - Granular Trap
Caswell - Gran Trap
Caswell - Lamella
COTS - Logs or Railroad Ties
COTS - Rubber Blocks
COTS - Tires
COTS - Wax/Plastic Blocks
Range Masters - TEC
Waterways Experiment Station - SACON
Societa FRA.SA - Elasoeric Granular Screen
DECELERATION
Action Target - TCT
Savage Range Systems - Passive Bullet Trap OM96
Shooting Ranges International - R493
IMPACT
Action Target - Thunder Ranch

Trap Descriptions

The following trap figures and descriptions are sorted according to bullet stopping mechanism (friction, deceleration, and impact). Each figure and associated description provides you with an image of the trap, a summary of how the trap works, the ammunition handled, and the estimated trap capacity prior to major maintenance.

Friction

Burleburger Schaumstoffwerk - REGUPOL

General Description: REGUPOL elastic material comes as pre-formed sheets or blocks of recycled polyurethane/rubber granules. A flexible material, REGUPOL can be used in a variety of thicknesses and configurations to absorb bullets, and cover overhead baffles or range floors to prevent ricochets. The manufacturer claims REGUPOL is heat and weather resistant and is suitable for outdoor range applications. Blocks of REGUPOL used in bullet traps are 500mm x 500mm x 200mm thick and stacked two blocks deep.

The REGUPOL sheet material (1250 mm wide by 10 to 20 mm thick) lies up against the block front to retain bullet fragments.

Ammunition:
Handgun.

Capacity: Manufacturer claims 10,000 rounds.

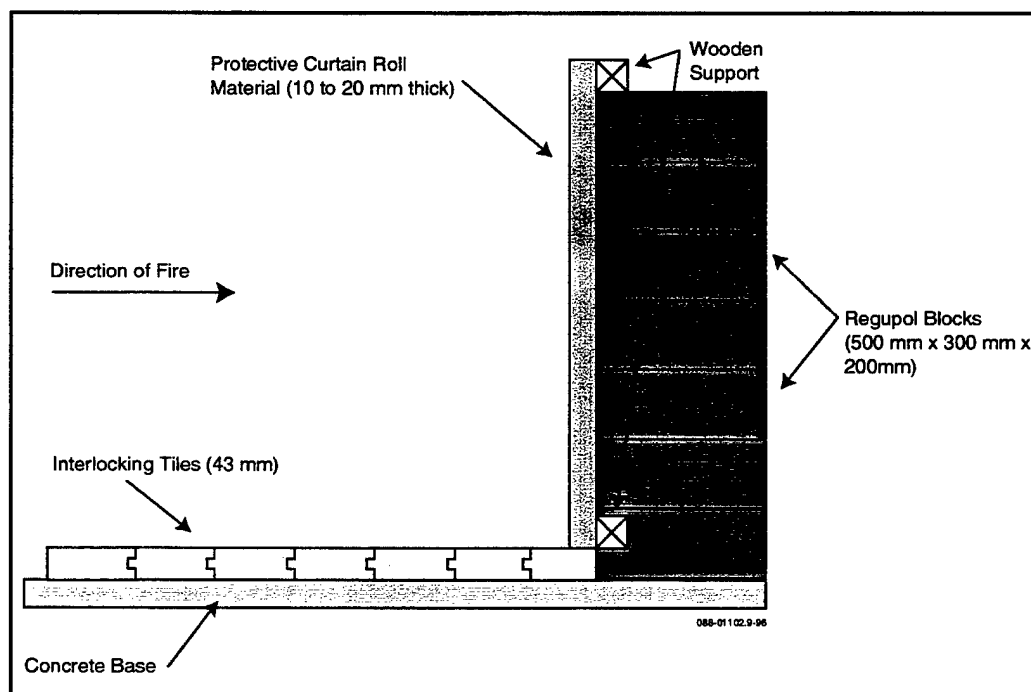

Capito & Assenmacher - Granular Trap

General Description: The components of this box shaped granular friction trap are from back to front as follows: armor plate back, plywood sides, granular rubber fill, 2 inches of polyurethane sheets retaining the fill, an air gap, and a rubber conveyor belt front. An access door at the back allows removal of the granular fill material and bullets by means of a truck-mounted vacuum system. This removed material undergoes bullet separation and up to 80 percent of the granular material is recycled back into the trap. Recovered bullets are generally intact. Upon firing, the bullet penetrates the front curtain and polyurethane sheet and is halted, generally within the first 12 inches, by the granulated material. In tests conducted so far,

tracer rounds have had no noticeable effect. The trap requires a level concrete pad.

Ammunition: Up to .50 cal.

Capacity: Manufacturer claims 25,000 rounds.

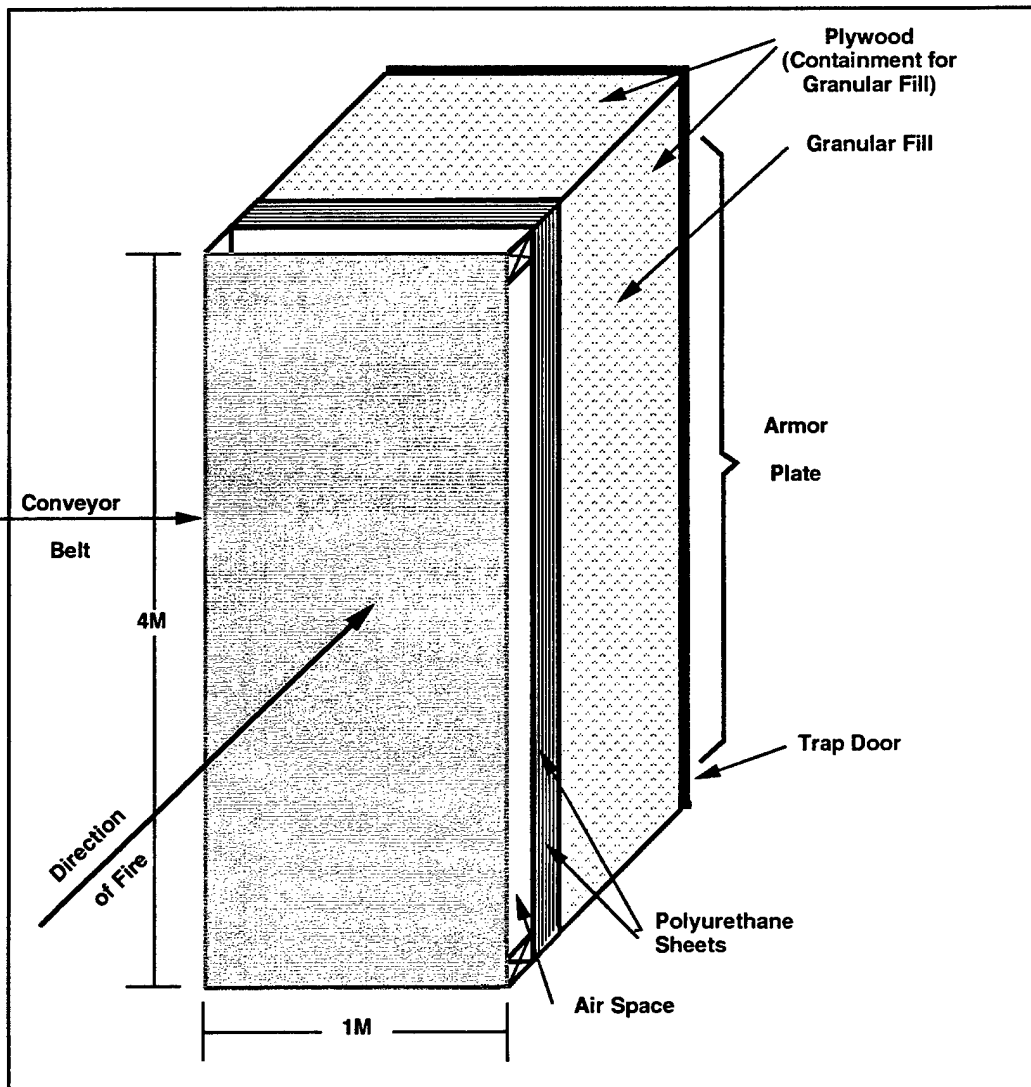

Caswell - Gran Trap

General Description: The Gran Trap is a large vertical box comprised of a steel frame with a steel back plate and plywood sides. A large rubber conveyor belt sheet bolts onto the plywood sides, forming the trap front. Granulated, recycled tire material (GranTex) fills the interior of the trap. The bullet penetrates the front sheet and is halted, generally within the first 12 inches, by the granulated material. Conveyor belt patches bolt onto the front panel to stop GranTex leakage, which result from focused areas of bullet impact.

Caswell recommends using a two stage vacuum/blower to separate the GranTex from the bullets in the collection trough at the front of the trap, and then recycling the GranTex material back into the top of the trap. Bullets recovered during this GranTex recycling are generally intact.

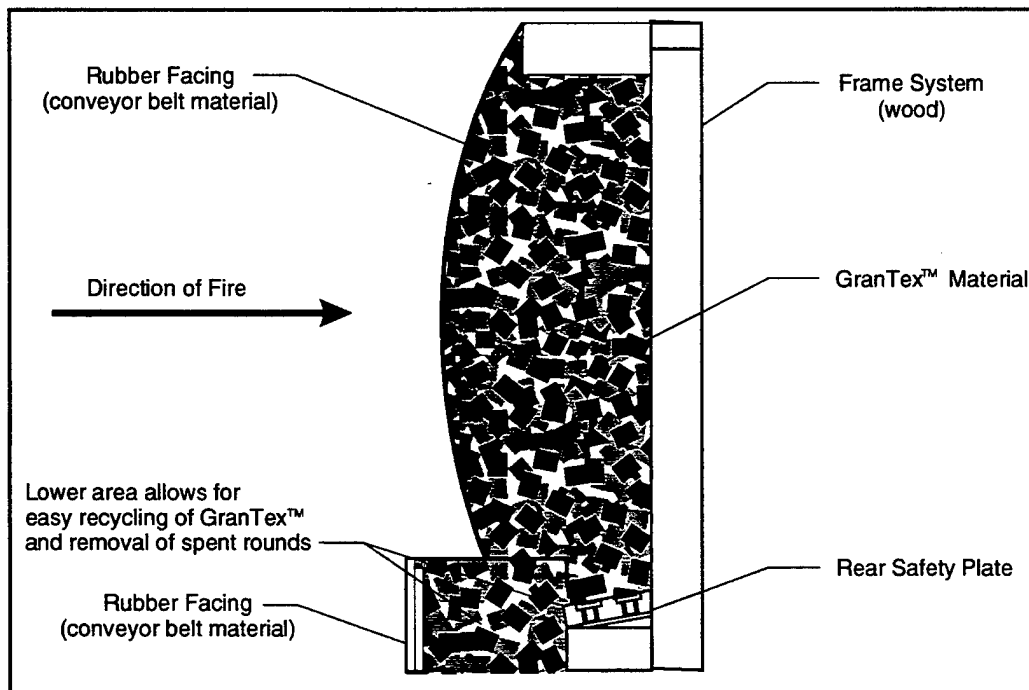

Ammunition: Up to .50 cal.

Capacity: Manufacturer claims 50,000 rounds.

Caswell - Lamella

General Description: The Lamella trap consists of a series of strips of recycled industrial conveyor belts, about 10 feet long, hung in a herringbone pattern (the front set looks like a partly closed venetian blind facing the firer). A shorter set of replaceable strips is attached to the front of this large trap to reduce the wear on the main trap. Bullets penetrate successive layers of the strips until they shed velocity and fall to the bottom of the trap. The bullets sometimes imbed themselves in the strips or, more often, become fragmented. As the individual lamella strips wear, they can be quickly rotated to other locations within the trap that receive less fire. The strips from those locations are moved to the high volume areas.

Ammunition: The trap has only been tested successfully against 7.62 mm, but the manufacturer claims it handles up to .50 caliber.

Capacity: Manufacturer claims 50,000 rounds before replacement of the lamella strips.

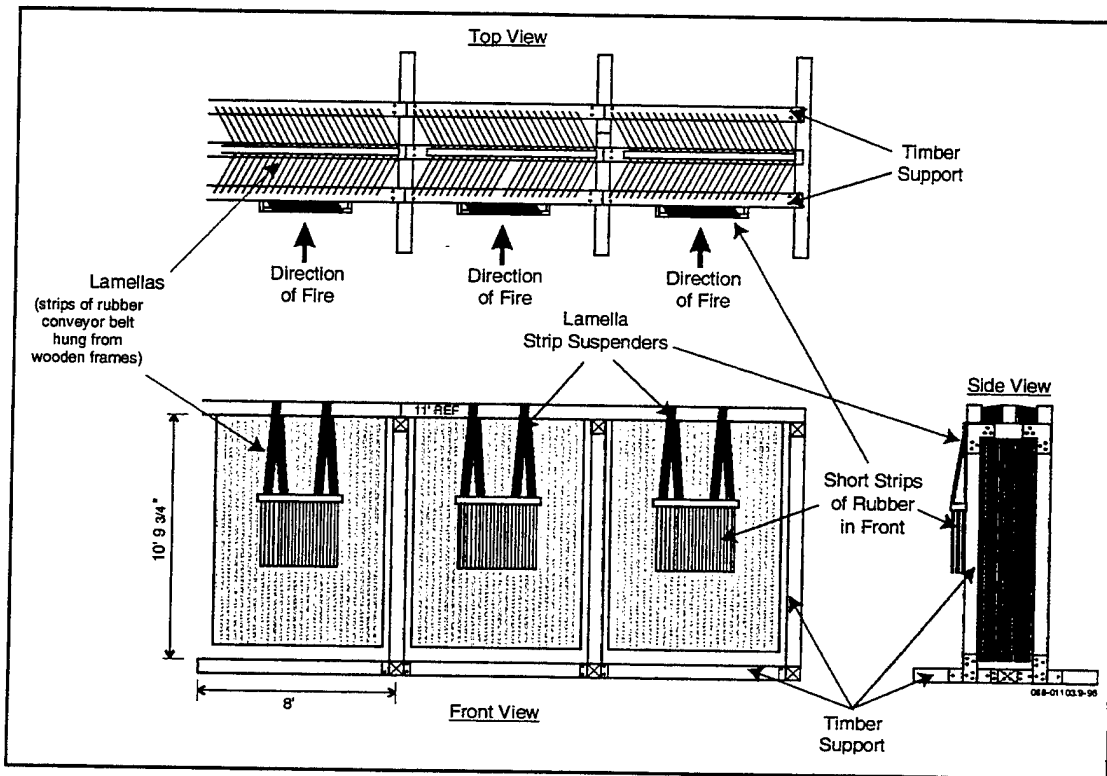

COTS - Logs or Railroad Ties

General Description: This simple outdoor trap uses railroad ties or logs stacked perpendicular to the axis of firing. Range personnel can stack the ties as deep or high as required. Rounds penetrate the wood and stop at various distances depending on the ammunition used. Rounds embedded in the wood are difficult to recover and the wood may require disposal. Various ranges use this method to protect the front of cement target coffins.

Ammunition: Up to 7.62 mm.

Capacity: Approximately 10,000 rounds.

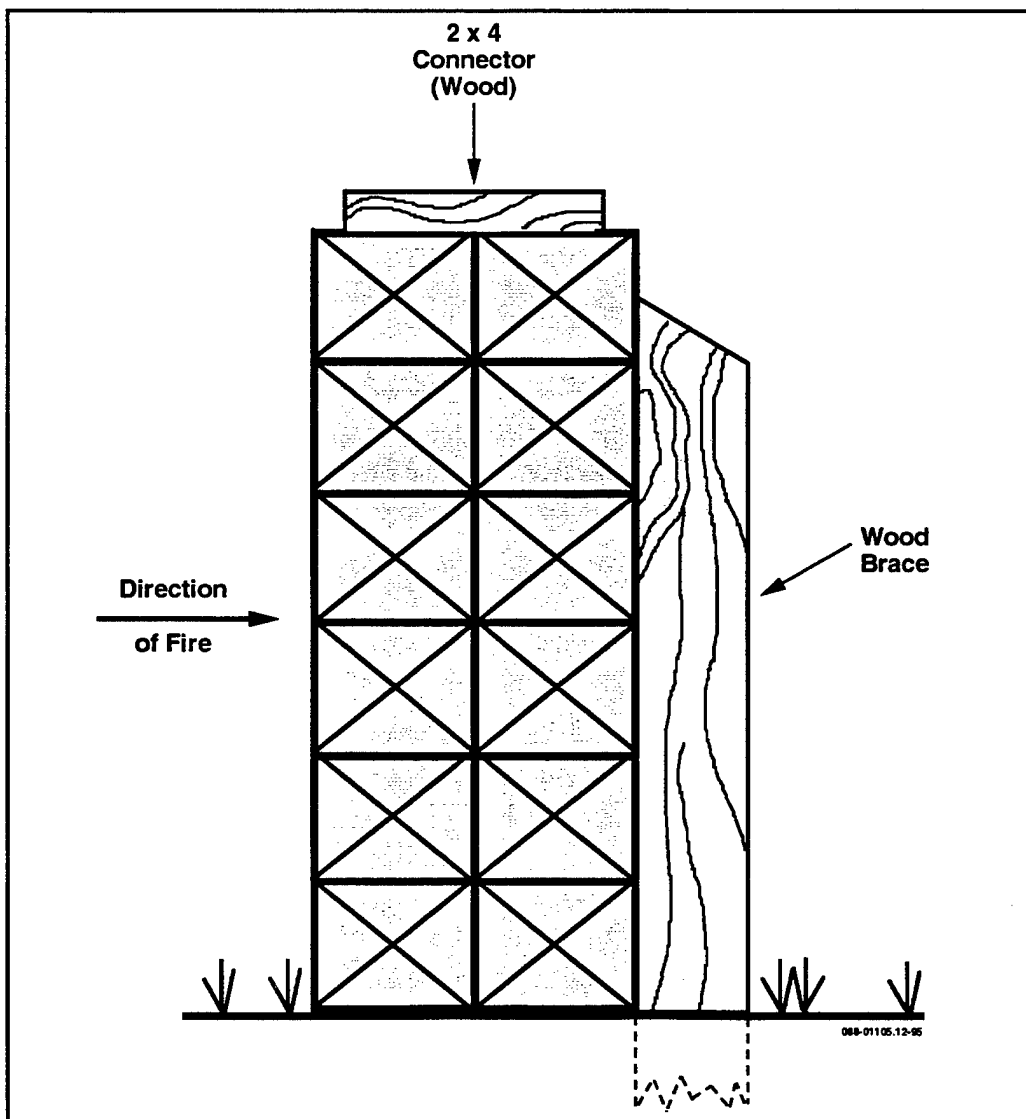

COTS - Rubber Blocks

General Description: Blocks of various rubber compounds or recycled rubber material are stacked to form a barrier. These blocks line indoor shooting houses and form a protective barrier around items such as fuel pipes adjacent to outdoor ranges. Blocks come in various sizes, but are generally around 60 to 80 pounds and measure 30 x 12 x 12. Bullets penetrate the block, and the friction of the rubber against the bullet surface causes the bullet to stop in a short distance, usually less than 2 feet. Blocks have the advantage of being modular, so that only the worn or filled blocks require replacement, reducing the labor and cost associated with maintenance. On the other hand, rubber may produce a fire hazard and many of these blocks require disposal as hazardous waste.

Ammunition:
Up to 7.62 mm.

Capacity:
Approximately
10,000 rounds.

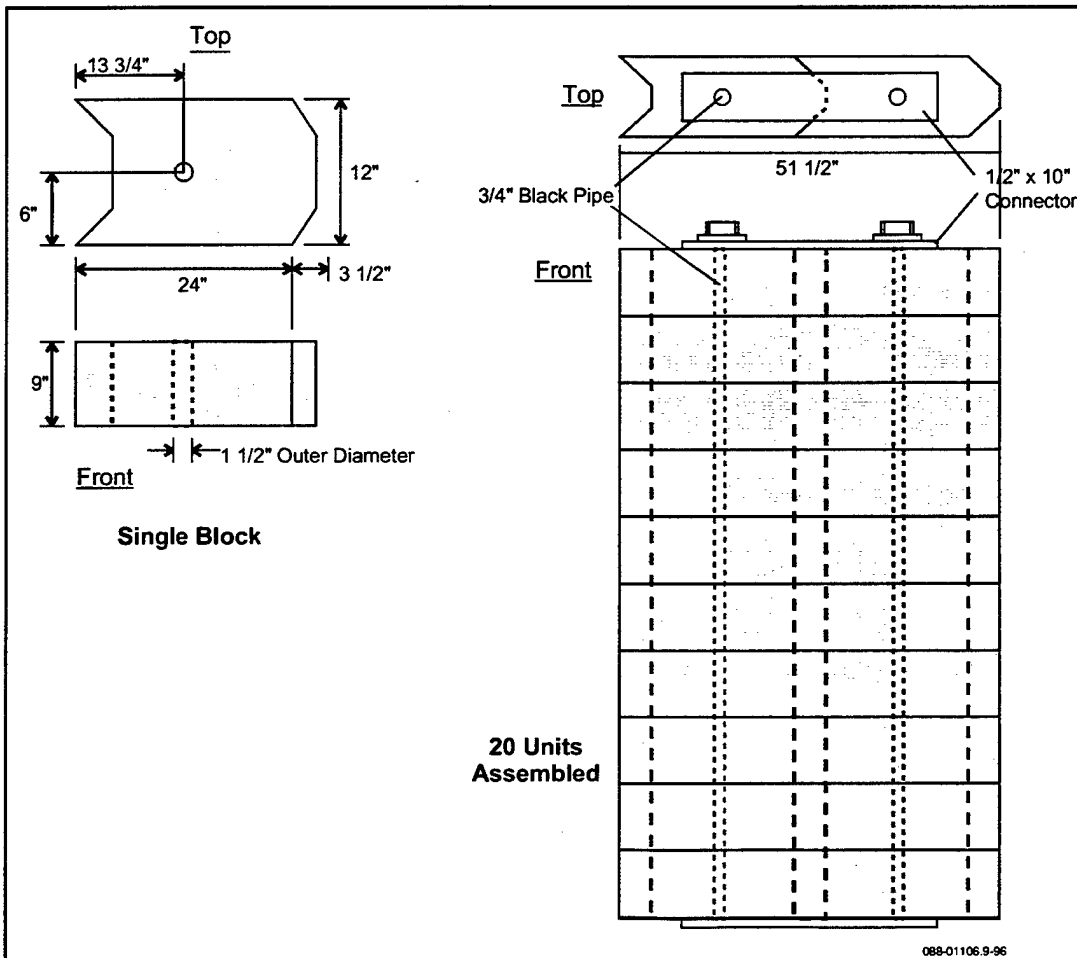

088-01106.9-96

COTS - Tires

General Description: Various ranges have used old vehicle tires, filled with sand or dirt, placed directly behind the targets, as bullet traps. Range personnel must then periodically disassemble the traps, sift the sand, recover the bullet fragments, and replace worn tires. This trapping method differs only slightly from direct fire into an earthen berm, thus reducing any environmental benefit derived from applying bullet traps to small arms ranges. In addition, TRADOC does not recommend this trap due to safety issues.

Ammunition: Up to 7.62 mm.

Capacity: Approximately 10,000 rounds.

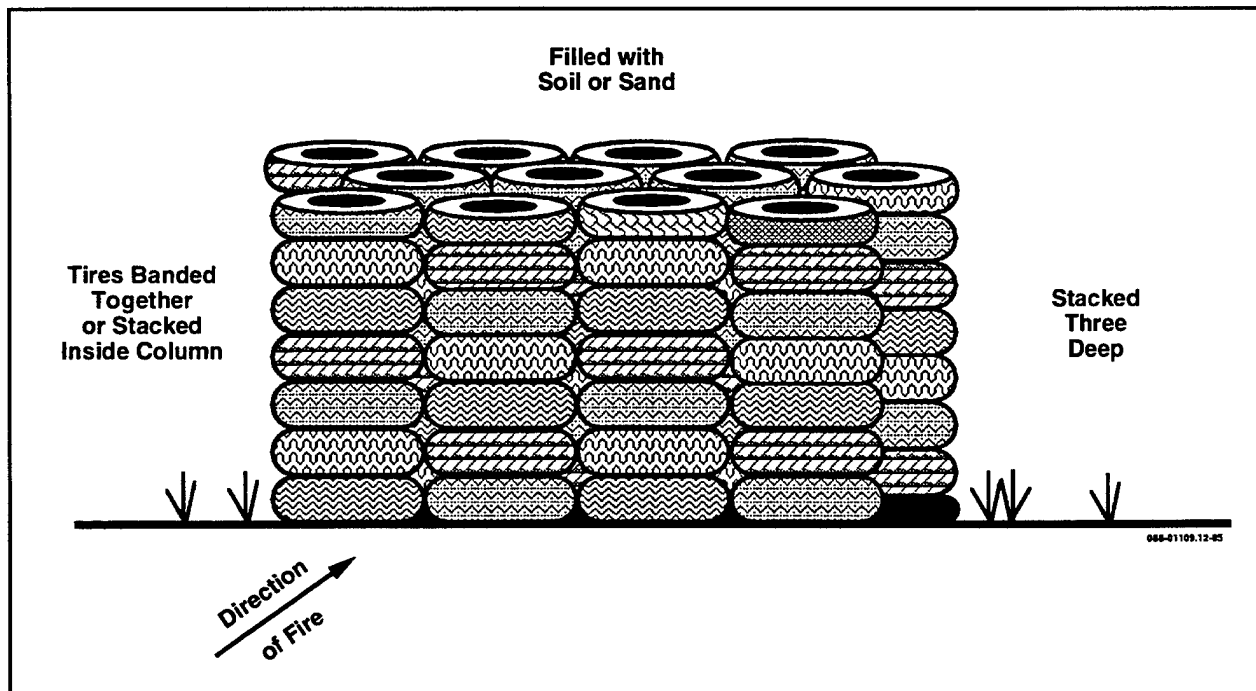

COTS - Wax/Plastic Blocks

General Description: Blocks of various wax and plastic compounds stack to form a barrier. Range personnel can stack the blocks as deep or high as required. Rounds penetrate the blocks and stop at various distances depending on the ammunition used. Rounds embedded in the blocks are difficult to recover and the block material may require disposal.

Ammunition: Up to 7.62 mm.

Capacity: Approximately 10,000 rounds.

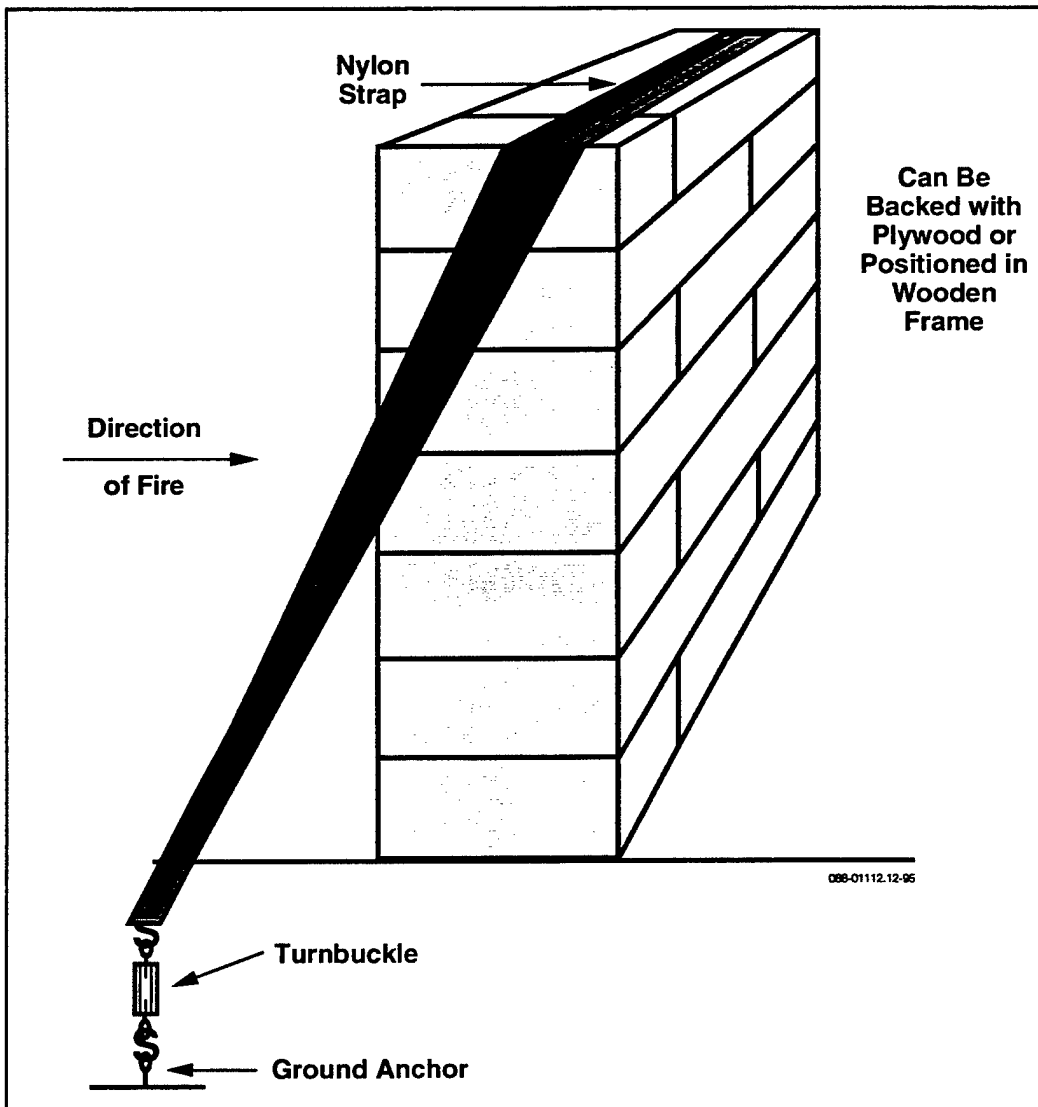

Range Masters - TEC

General Description: The TEC system consists of a set of large blocks molded from shredded, recycled tires in a matrix of Kevlar® reinforced bonding mixture. The blocks weigh approximately 60 pounds each and measure about 30 x 12 x 9 inches. The trap consists of blocks placed on an inclined platform which is protected from oncoming rounds by ground baffles made of the same blocks as the bullet trap. Blocks look similar to oversized cinder blocks. The fired round penetrates the front of the block, shedding velocity until it hits one of the recovery channels, where it falls into the collection tray. Recovery channel positions may be manufactured according to the ammunition type. Intact bullets may be recovered and recycled by emptying the recovery tray at the base.

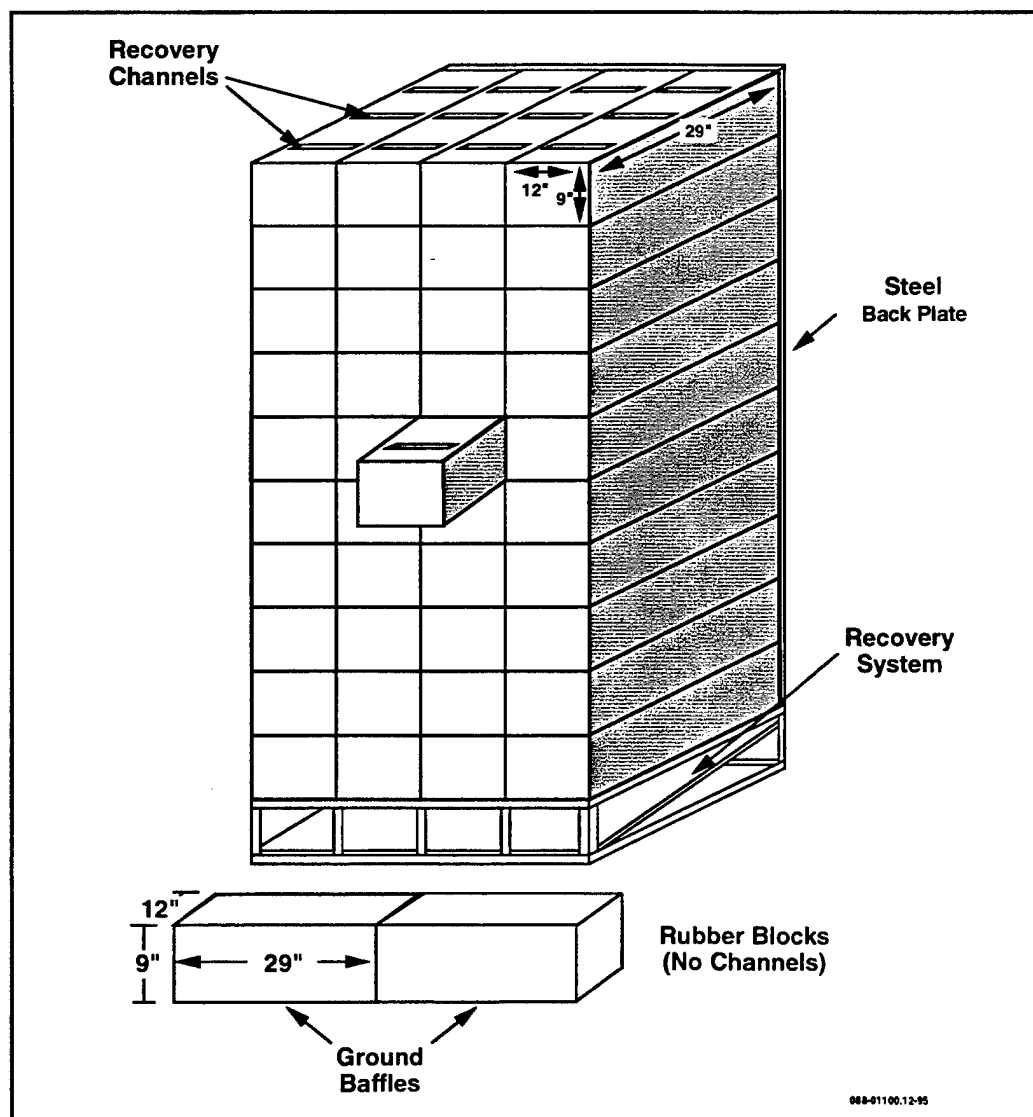

Ammunition: Up to 7.62 mm.

Capacity: The manufacturer claims 10,000 to 20,000 rounds before the blocks need to be rotated, depending upon the type of ammunition used.

Waterways Experiment Station - SACON

General Description: SACON (Shock Absorbing Concrete) combines a low density material (steel fibers or polypropylene fibers) with concrete. The substitution of this material for conventional gravel aggregate achieves densities of 60 to 90 pounds per cubic foot compared to conventional concrete at 150 pounds per cubic foot. This composition allows SACON to absorb bullets and shock waves (e.g. like those generated on light demolition ranges). SACON is poured into preformed molds according to the shape and color determined by the user. Large panels previously applied to indoor ranges were fitted into steel I-beam brackets and grouped into walls. Although the material takes 28 days to cure, applying the blocks in modular, or tile-like format, only requires replacement of the worn or filled blocks, reducing the labor and cost associated with maintenance. Additionally, unlike rubber or wax material,

SACON may have the advantage of recyclability (trial recycling tests are underway), reducing or eliminating disposal costs.

Ammunition: Up to 7.62 mm.

Capacity: Estimated capacity of 10,000 rounds before recycling.

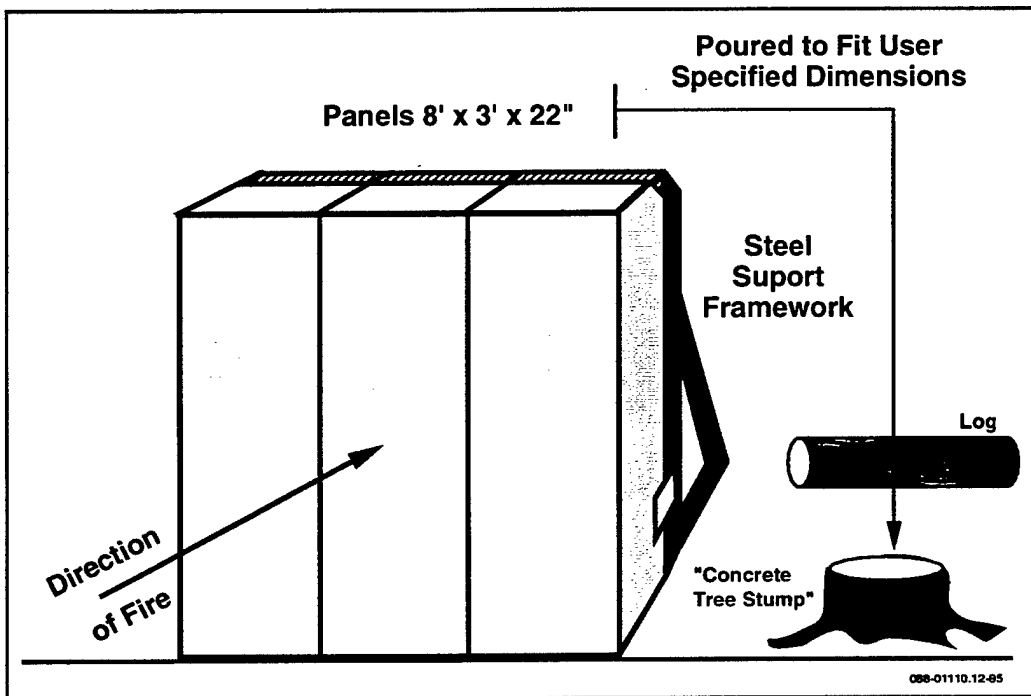

Societa FRA.SA - Elastomeric Granular Screen

General Description: Loose rubber granules lie against a support structure back and a conveyor belt bottom. Bullets enter the granules, lose their velocity and stop. The conveyor belt operates daily to bring the granules and bullets to a sifting/vacuum system. The vacuum dumps granules (minus the bullets) at the top of the granules pile. Bullets generally remain intact, making recycling relatively easy. Granules may require disposal as hazardous waste.

Ammunition: Up to 7.62 mm.

Capacity: The manufacturer claims 100,000 rounds before replacing the granules.

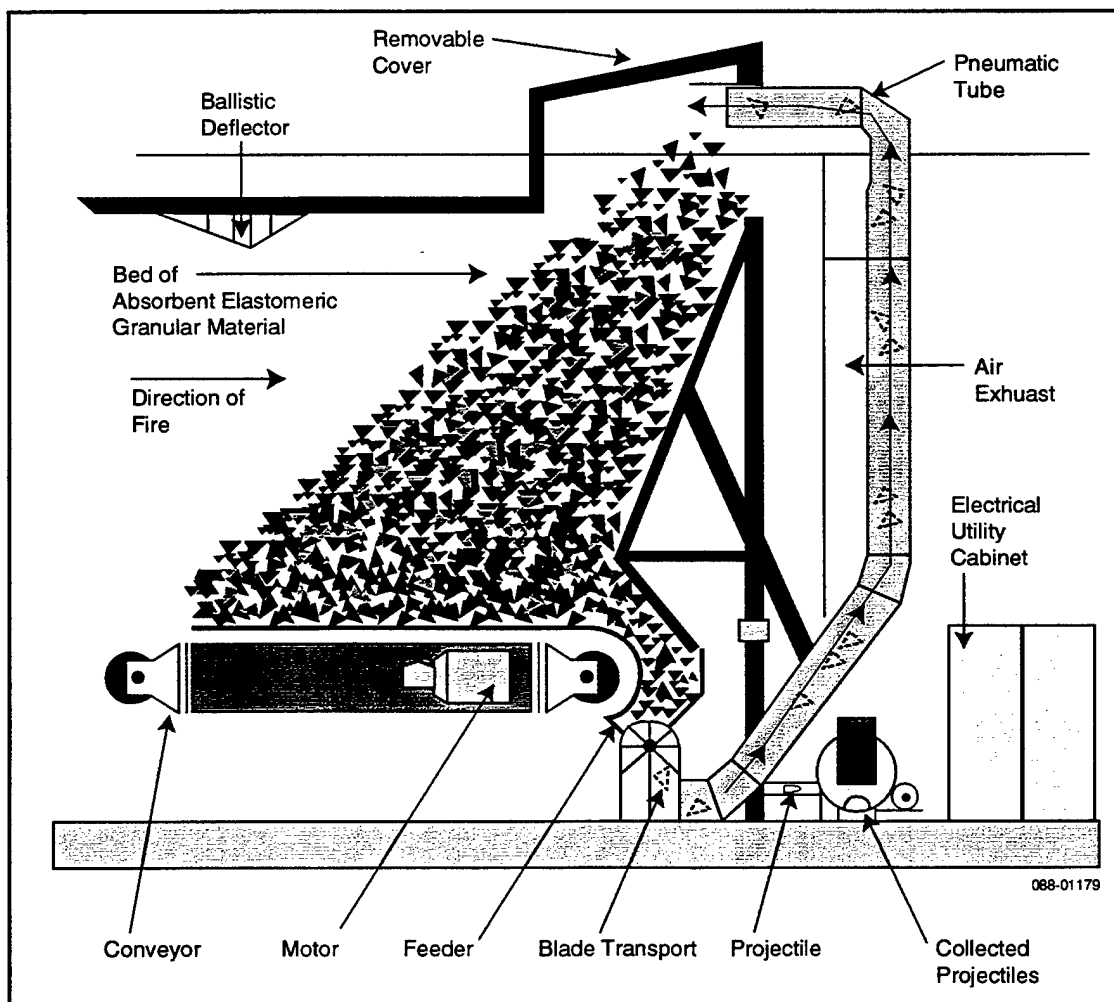

Deceleration

Action Target - Total Containment Trap (TCT)

General Description: This trap has steel plates on top and bottom set at an angle of 12 degrees from horizontal to deflect bullets into the trap. The bullets enter the trap, striking a series of angled impact plates oriented in a circular shape, to direct them into a collection plate. Steel plates are bolted onto the deceleration chamber for easy removal and replacement. Traps sit on a level concrete base.

Ammunition: Up to 7.62 mm.

Capacity: The initial contact portion of the trap is anticipated to last for 250,000 rounds.

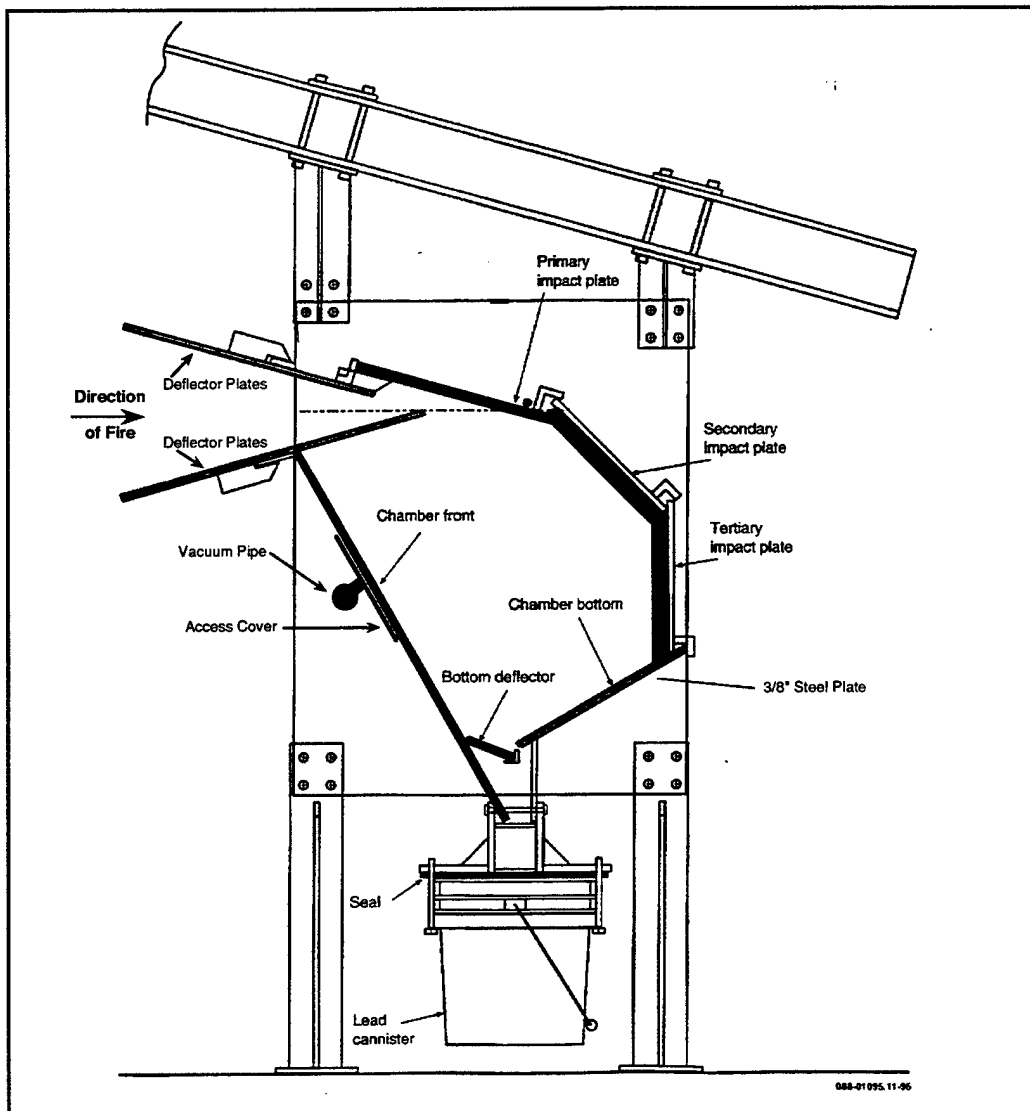

Savage Range Systems - Passive Bullet Trap OM96

General Description: This trap has steel plates on top and bottom set at an angle of 12 degrees from horizontal to deflect bullets into the trap. An injector introduces a fine spray of water and water-soluble oil at the point of entry into the deceleration chamber to coat the bullet. The bullet spins in a vertical plane around the deceleration chamber until it loses its velocity and slides backward to drop through a slot into a collection tray. The unused spray is recycled back into a reservoir. Steel plates are bolted onto the deceleration chamber for easy removal and replacement. Traps sit on a level concrete base.

Ammunition: Up to .50 cal.

Capacity: The initial contact portion of the trap is anticipated to last for at least 250,000 rounds. Up to 25,000 rounds between emptying of the collection tray can be handled before bullets begin backing up into the trap.

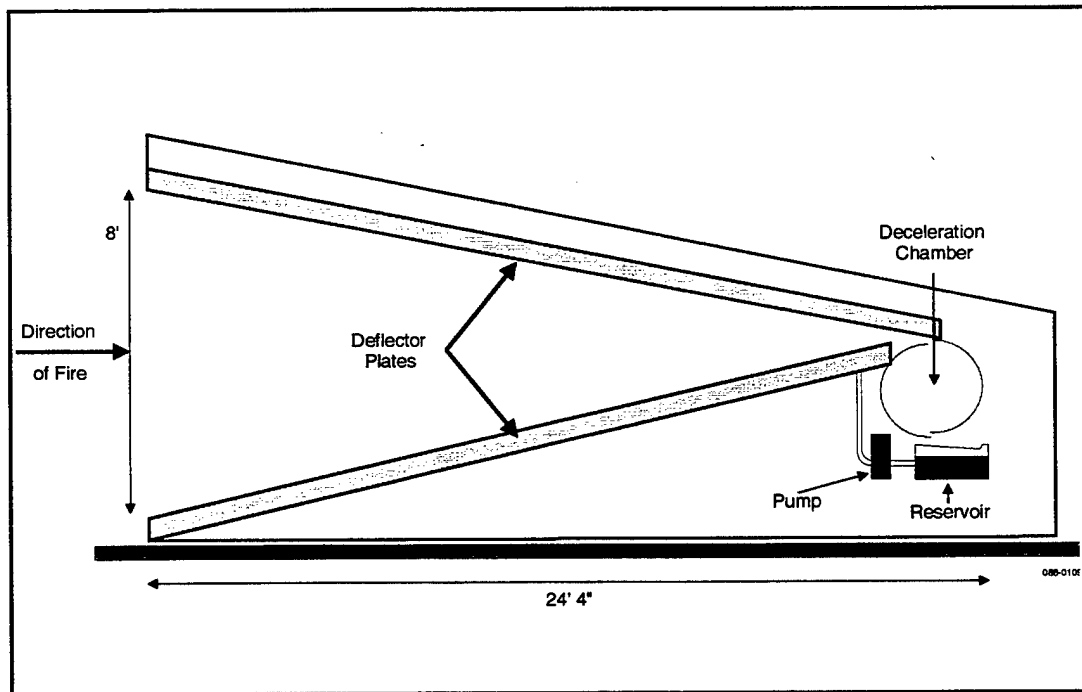

Shooting Ranges International - R493

General Description: This trap has four angled hardened steel plates per firing position to funnel bullets into a vertical aperture of a helical chamber. There, the bullets spin in a horizontal plane until they lose velocity and drop into a collection container. Traps sit on a level concrete base.

Ammunition: Up to 7.62 mm.

Capacity: The initial contact portion of the trap is anticipated to last for at least 500,000 rounds.

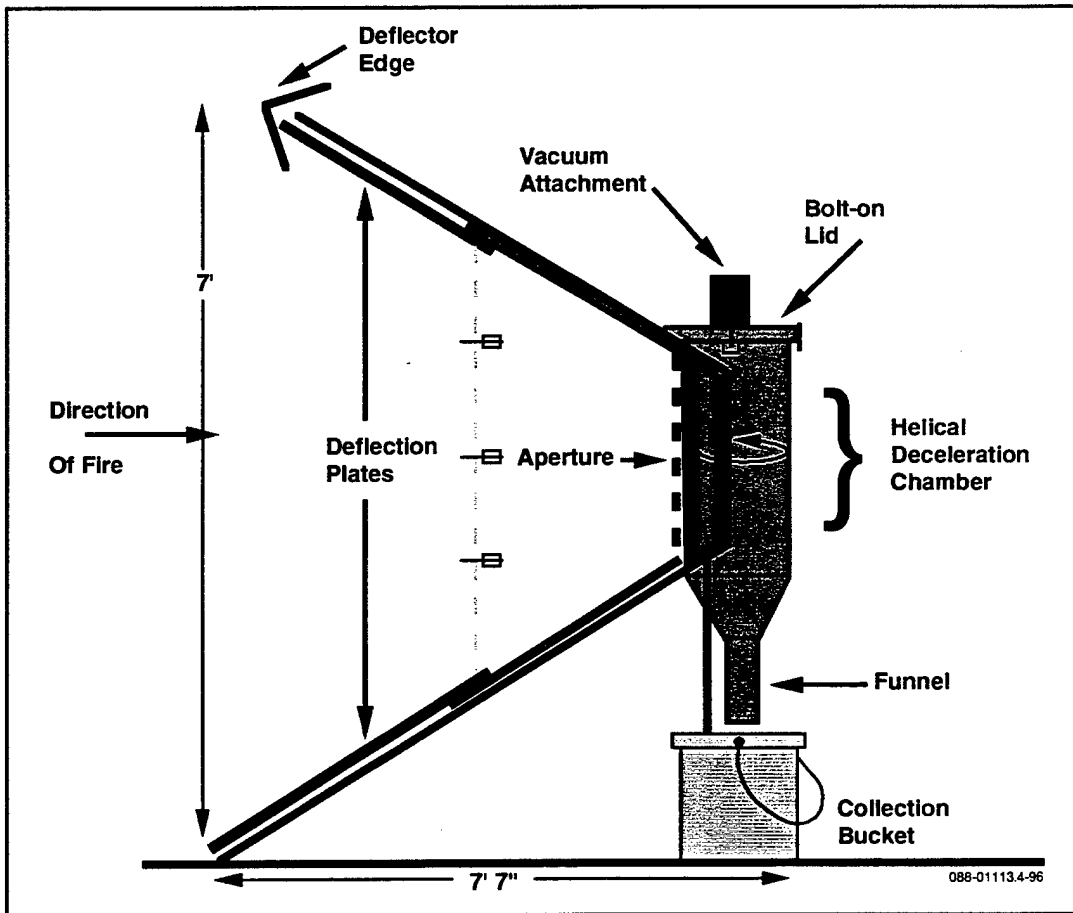

Impact

Action Target - Thunder Ranch

General Description: The Thunder Ranch trap consists of two 2 x 4 lumber legs which form the sides of a steel backed box at the top of the legs. The box which catches the bullets has a 1/4 inch armor plate on the back (30 in. wide by 48 in. high), held in place by lag screws. On the front of the box, a sheet of plywood with a sheet of Linatex attached (on the inside) is screwed into the lumber legs, and 2 x 4s which form the box's top and bottom. Linatex is a self sealing material. Targets are attached to the box front. Angle iron lies against the inside two sides of the box, so that as bullets fragment, they do not excessively wear the 2 x 4 legs. The bullet pierces the trap and hits the Linatex. The Linatex stretches until the bullet contacts the back armor plate and fragments. The Linatex then snaps back and seals, forming a barrier to the bullet fragments. The fragments fall to the bottom of the box for

collection. It is believed that by replacing the 2 x 4 legs with 2 x 6's, the life of the Linatex barrier could be extended by up to 50 percent. Ammunition other than standard ball ammunition, such as hollowpoint, wadcutter, or frangible rounds, tends to cause accelerated wear of the Linatex.

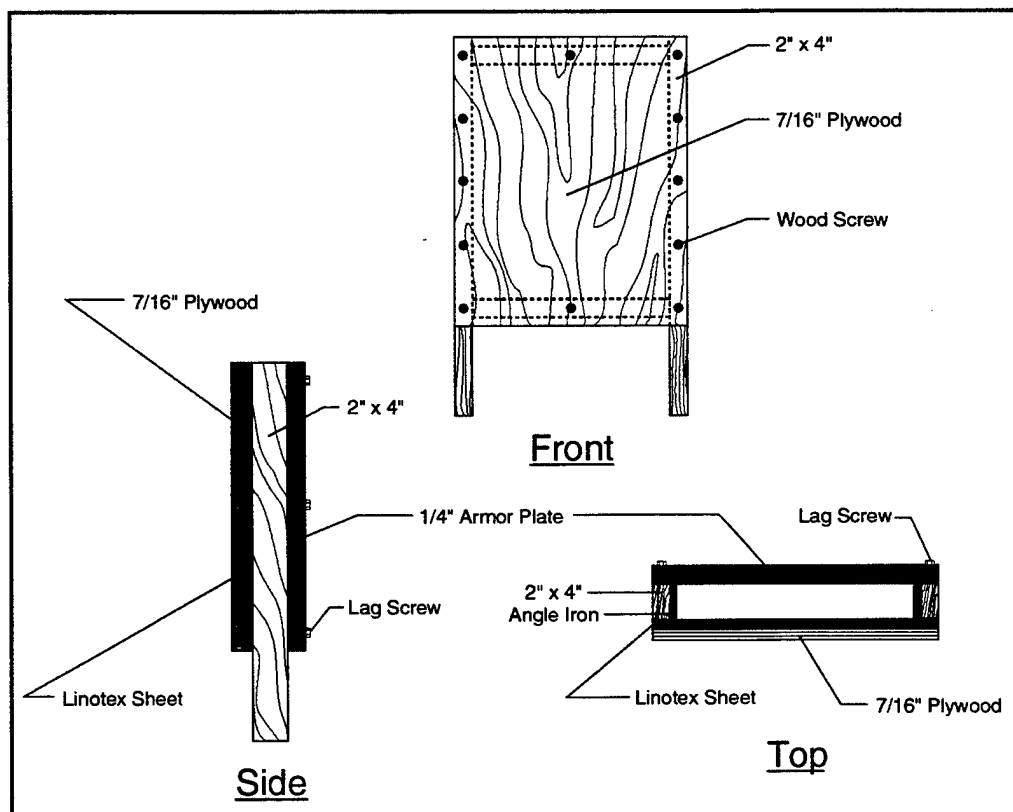

Ammunition:
Handgun.

Capacity: Emptying of bullet fragments is recommended at approximately 3,000 rounds. Life of the Linatex barrier will depend on the type of ammunition used, but is expected to be at least 10,000 rounds.

Analysis Summary

Now you have a sense of the available bullet traps and want to know which trap types apply to your range. Table 2 (AEC report number: SFIM-AEC-ET-CR96195) summarizes the evaluation of bullet traps across the four range types. This table lists most of the evaluation criteria across the top, the bullet traps along the left margin, and the ranges where individual traps apply along the right margin. You can see that all bullet traps do not apply to all small arms ranges. Also, traps listed as applicable to a range may apply only at certain target distances. The evaluation criteria in Table 2 are grouped into Cost, Performance, and Maintenance categories. Bullet traps previously assessed as not feasible (AEC report number: SFIM-AEC-ET-CR96195) are not shown in Table 2. Also you may refer to the Bullet Trap Feasibility Assessment for additional details regarding the evaluation criteria and minimum acceptable values (AEC report number: SFIM-AEC-ET-CR96195).

Table 3 takes the range specific evaluation criteria (Masking, Potential Capture Rate, and Giving Away the Target Location), groups the bullet traps into broad categories according to how they fit these categories. The table then shows which groups of bullet traps apply at specific target distances. On each range, a bullet trap may or may not work at certain target distances due to masking or because the trap gives away the target location. Table 3 indicates, by shading, the unfeasible traps. The column on the far right indicates the reason for this assessment, or recommends ideas to help you better utilize the trap to avoid masking or camouflage problems. Figures 1 through 4 also illustrate why certain categories of traps will or will not work for specific distances, generally due to their ability/inability to let the firer see down range targets (i.e. masking - Table 3). A word of caution also regarding Potential Capture Rates used in Table 3; these are estimates of installation range managers, not measured individual target hits for individual targets. The analysis of Masking, or obscuring the firer's view of down range targets, assumes that all ranges are flat or horizontal. Therefore, consider the terrain on your range before assuming target visibility with various traps.

Use Tables 2 and 3 to select a trap that best meets all of the criteria you establish for your range. After reading in more detail the sections on cost and maintenance, you will have a clearer picture of how you want to weigh these criteria to choose a bullet trap to meet your individual needs.

Table 2 - Bullet Trap Evaluation by Individual Criteria

Trap Type	Cost		Performance				Maintenance			Applicable Range Type				
	Capital Cost	Maintenance Cost (per year)	Catch Rounds ?	Contain Metal Fragments?	Dispose Rubber/Plastic/Metal/Wood?	Ammun. applicable (up to and including)	# Rounds to replacement or major refurbishment (per lane)	Duration of Annual Maintenance (for 20 firing points)	Duration of Monthly Maintenance (for 20 firing points)	25 m	A F F	A R F	C P Q C	
Deceleration:														
Action Target-TCT	\$\$\$\$	\$\$	Y	Y	N	7.62	250,000	1 day	2-3 hours	•	•	•	•	
Savage-OM96	\$\$\$\$	\$\$	Y	Y	N	.50 cal.	250,000	1 day	2-3 hours	•	•	•	•	
Shooting Rngs Int.- R493	\$\$\$\$	\$\$	Y	Y	N	7.62	500,000	1 day	2-3 hours	•	•	•	•	
Impact:														
Action Target-Thunder Rech	\$	\$	Y	Y	N	handgun	10,000	1 day	1 hour					
Friction:														
Burleburger-REGUPOL	\$\$\$	\$\$\$	Y	Y	Y	handgun	10,000	2-3 days	2-3 hours					
Capito-Granular Trap	\$\$\$\$	\$\$\$	Y	Y	Y	.50 cal.	25,000	1 week	1 day	•	•	•	•	
Caswell-Gran Trap	\$\$\$\$	\$\$\$	Y	Y	Y	.50 cal.	50,000	1 week	1 day	•	•	•	•	
Caswell-Lamella	\$\$\$\$	\$\$\$	Y	Y	Y	.50 cal.	50,000	2-3 days	2-3 hours	•	•	•	•	
COTS-Logs	\$	\$\$\$	Y	Y	Y	7.62	10,000	1 week	2-3 hours	•	•	•	•	
COTS-Rubber Blocks	\$	\$\$\$	Y	Y	Y	7.62	10,000	1 week	2-3 hours	•	•	•	•	
COTS-Tires	\$	\$\$\$	Y	Y	Y	7.62	10,000	1 week	2-3 hours	•	•	•	•	
COTS-Wax/Plastic Blocks	\$	\$\$\$	Y	Y	Y	7.62	10,000	1 week	2-3 hours	•	•	•	•	
Range Masters-TEC	\$\$\$	\$\$\$	Y	Y	Y	7.62	10,000	2-3 days	2-3 hours	•	•	•	•	
WES-SACON	\$\$	\$\$	Y	Y	N	7.62	10,000	2-3 days	2-3 hours	•	•	•	•	
Societa FRA-Eastomeric	\$\$\$\$	\$\$\$	Y	Y	Y	7.62	100,000	1 week	1 day	•	•	•	•	

COTS=Commercial Off-the-Shelf Materials, \$=lowest cost, \$\$\$=highest cost; Y=Yes; N=No

Table 3
Bullet Trap Evaluation Which Distinguish the Four Range Types

Range Type & Target Distances	Masking (Yes/No/NA)	Potential Capture Rate (percent)	Give Away Trap Location (Yes/No/NA)	Comments
25m:				
Helical Deceleration (Action Target- TCT, Savage-OM96, Shooting Ranges Int.-R493) **	NA	98	NA	
Venetian Blind Friction (Caswell-Lamella)	NA	98	NA	
Rubber Block Friction (Range Masters-TEC)	NA	98	NA	
Concrete Block Friction (WES-SACON)	NA	98	NA	
Granular Rubber Friction (Capito-Granular Trap, Caswell-Gran Trap, Societa FRA-Elastom.)	NA	98	NA	
COTS Friction (Logs, R. Blck, Tires, Wx/Pl. Blck)	NA	98	NA	
Automat. Field Fire (AFF):				
Helical Deceleration (Action Target- TCT, Savage-OM96, Shooting Ranges Int.-R493)				
75m	No	70	NA	size to avoid masking
175m	No	60	NA	size to avoid masking
300m	No	30	NA	
Venetian Blind or Granular Friction (Caswell-Lamella, Capito-Granular Trap, Caswell-Gran Trap, Societa FRA-Elastom.)				
75m	No	>70	NA	size to avoid masking
175m	No	>60	NA	size to avoid masking
300m	No	>30	NA	
Rubber or concrete Block Friction (Range Masters-TEC, WES-SACON); and COTS Friction (Logs, R. Blck, Tires, Wx/Pl. Blck)				
75m	No	approx. 80	NA	utilize vertical and horizontal blocks
175m	No	approx. 80	NA	utilize vertical and horizontal blocks
300m	No	approx. 80	NA	utilize vertical and horizontal blocks
Automat. Record Fire (ARF):				
Helical Deceleration (Action Target- TCT, Savage-OM96, Shooting Ranges Int.-R493)				
50m	No	85	Yes	unlikely to camouflage
100m	No	75	Yes	unlikely to camouflage
150m	Yes	65	Yes	unlikely to camouflage
200m	Yes	50	Yes	unlikely to camouflage
250m	Yes	30	Yes	unlikely to camouflage
300m	No	30	Yes	unlikely to camouflage
Box Granular Friction (Capito-Granular Trap, Caswell-Gran Trap.)				
50m	No	85	No	lay flush with ground; camouflage
100m	No	75	No	lay flush with ground; camouflage
150m	No	65	No	lay flush with ground; camouflage
200m	No	50	No	lay flush with ground; camouflage
250m	No	30	No	lay flush with ground; camouflage
300m	No	30	No	lay flush with ground; camouflage

**Bullet trap manufacturers are grouped according their size/shape/modular nature and compatibility with camouflage.
Shaded=does not meet range specific criteria; Bold=criteria not met.

Bullet Trap User's Guide

(Table 3 continued)

Range Type & Target Distances	Masking (Yes/No/NA)	Potential Capture Rate (percent)	Give Away Trap Location (Yes/No/NA)	Comments
Venetian Blind or Open Granular Friction (Caswell Lamella, Societa FRA-Elastom.)				
50m	No	85	Yes	unlikely to camouflage
100m	No	75	Yes	unlikely to camouflage
150m	Yes	60	Yes	unlikely to camouflage
200m	Yes	50	Yes	unlikely to camouflage
250m	Yes	30	Yes	unlikely to camouflage
300m	No	30	Yes	unlikely to camouflage
Rubber or concrete Block Friction (Range Masters-TEC, WES-SACON); and COTS Friction (Logs, R. Blck, Tires, Wx/Pl. Blck)				
50m	No	>85	No	mold/color blocks to blend with env.; utilize vertical and horizontal blocks
100m	No	>75	No	mold/color blocks to blend with env.; utilize vertical and horizontal blocks
150m	No	>65	No	mold/color blocks to blend with env.; utilize vertical and horizontal blocks
200m	No	>50	No	mold/color blocks to blend with env.; utilize vertical and horizontal blocks
250m	No	>30	No	mold/color blocks to blend with env.; utilize vertical and horizontal blocks
300m	No	>30	No	mold/color blocks to blend with env.; utilize vertical and horizontal blocks
Combat Pistol Qual. Course:				
Helical Deceleration (Action Target- TCT, Savage-OM96, Shooting Ranges Int.-R493)				
10m	Yes	95	NA	will mask view of down-range targets
13m	Yes	90	NA	will mask view of down-range targets
16m	Yes	75	NA	will mask view of down-range targets
17m	Yes	75	NA	will mask view of down-range targets
23m	Yes	65	NA	will mask view of down-range targets
27m	Yes	65	NA	will mask view of down-range targets
31m	No	50	NA	
Box Granular Friction (Capito-Granular Trap, Caswell-Gran Trap.)				
10m	No	95	NA	lay near flush with ground
13m	No	90	NA	lay near flush with ground
16m	No	75	NA	lay near flush with ground
17m	No	75	NA	lay near flush with ground
23m	No	65	NA	lay near flush with ground
27m	No	65	NA	lay near flush with ground
31m	No	50	NA	lay near flush with ground

**Bullet trap manufacturers are grouped according their size/shape/modular nature and compatibility with camouflage.

Shaded=does not meet specific criteria; Bold=criteria not met.

Bullet Trap User's Guide

(Table 3 continued)

Range Type & Target Distances	Masking (Yes/No/NA)	Potential Capture Rate (percent)	Give Away Trap Location (Yes/No/NA)	Comments
Venetian Blind (Caswell Lamella)				
10m	Yes	95	NA	size masks view of down-range targets
13m	Yes	90	NA	size masks view of down-range targets
16m	Yes	75	NA	size masks view of down-range targets
17m	No	75	NA	size to avoid masking
23m	No	65	NA	size to avoid masking
27m	No	65	NA	size to avoid masking
31m	No	50	NA	
Open Granular Friction (Societa FRA-Elastom.)				
10m	Yes	95	NA	size masks view of down-range targets
13m	Yes	90	NA	size masks view of down-range targets
16m	Yes	75	NA	size masks view of down-range targets
17m	Yes	75	NA	size masks view of down-range targets
23m	Yes	65	NA	size masks view of down-range targets
27m	Yes	65	NA	size masks view of down-range targets
31m	No	50	NA	
Rubber or concrete Block Friction (Range Masters-TEC, WES-SACON, Burleburger-REGUPOL)				
10m	No	95	NA	mold/color blocks to blend with env.; use horizontal blocks in-front of target
13m	No	90	NA	mold/color blocks to blend with env.; use horizontal blocks in-front of target
16m	No	75	NA	mold/color blocks to blend with env.; use horizontal blocks in-front of target
17m	No	75	NA	mold/color blocks to blend with env.; use horizontal blocks in-front of target
23m	No	65	NA	mold/color blocks to blend with env.; use horizontal blocks in-front of target
27m	No	65	NA	mold/color blocks to blend with env.; use horizontal blocks in-front of target
31m	No	50	NA	mold/color blocks to blend with env.; use horizontal blocks in-front of target
Steel-backed wooden box Impact (Action Target-Thunder Ranch)				
10m	Yes	95	NA	size masks view of down-range targets
13m	Yes	90	NA	size masks view of down-range targets
16m	Yes	75	NA	size masks view of down-range targets
17m	No	75	NA	size to avoid masking
23m	No	65	NA	size to avoid masking
27m	No	65	NA	size to avoid masking
31m	No	50	NA	size to avoid masking

**Bullet trap manufacturers are grouped according their size/shape/modular nature and compatibility with camouflage. Shaded=does not meet range specific criteria; Bold=criteria not met.

Based upon the information in Tables 2 and 3, above, the Bullet Trap Feasibility Assessment concluded that bullet traps provide an environmentally sound alternative to firing directly into the environment at small arms ranges. They have the potential to retain metal fragments and prevent erosion on ranges.

The following list, by range, summarizes the bullet traps which apply to the four range types at specific distances:

25 meter Range: The low dispersion of fire (98% capture rate) and lack of masking or camouflage requirements allows you to choose a bullet trap based upon maintenance and cost factors. Most of the traps will function on this range.

Deceleration traps will work best for high target receive rate ranges (>100,000 rounds per year per target) (Action Target - TCT; Savage - OM96; Shooting Ranges International - R493).

Friction traps will work for ranges with lower target receive rate (see Estimating Target Receive Rates page 35), particularly those with less than 10,000 rounds per year per target (Capito - Granular Trap; Caswell - Gran Trap; Caswell - Lamella, COTS Logs, Rubber Blocks, Wax, Plastic; Range Masters - TEC; WES-SACON; Societa FRA - Elastomeric).

Automated Field Fire: As the potential capture rate decreases to 70%, 60% and 30% for distances 75M, 175M, and 300M respectively, the utility of deceleration traps also decreases, because these traps have a fixed capture radius. Friction traps may provide a higher capture rate (up to 80%) where the trap material is spread over a greater area near the target coffin; but these traps require more frequent maintenance than deceleration traps (maintenance every 10,000-50,000 rounds versus 250,000-500,000 rounds).

Deceleration traps will work best for high target receive rate ranges (>100,000 rounds per year per target) and particularly for the 175 meter target which generally receives the highest volume of fire per firing lane (Action Target - TCT; Savage - OM96; Shooting Ranges International - R493).

Friction traps will work for ranges with lower target receive rates, particularly those with less than 10,000 rounds per year, per target (Capito - Granular Trap; Caswell - Gran Trap; Caswell - Lamella, COTS Logs, Rubber Blocks, Wax, Plastic; Range Masters - TEC; WES - SACON).

Automated Record Fire: This range has both camouflage and masking requirements. This eliminates both tall bullet traps, which would mask down range targets, and bullet traps not compatible with full body coloration. This leaves only low lying friction traps. Increased dispersion of fire from the 50 meter (85% capture rate) to the 300 meter targets (30% capture rate) implies that you must employ these low lying friction traps over a significant area in order to capture rounds.

Friction traps apply to this range. You may apply these traps in a modular format, like tiles, rotating out the parts which fill up first and replacing them with a presized, preformed modules (Capito - Granular Trap; Caswell - Gran Trap; COTS Logs, Rubber Blocks, Wax, Plastic; Range Masters - TEC; WES - SACON).

Combat Pistol Qualification Course: No camouflage requirement exists here. Although the targets lie no farther than 31 meters down range, and the potential capture rates do not fall below 50%, the close down-range target spacing on this range permits only low lying traps out to 31 meters. This leaves only low friction traps placed modularly over the currently scarred surface or well placed boxed impact traps as feasible solutions out to 31 meters. At 31 meters, even the tall deceleration traps work, because they do not obstruct the view of any down range targets.

Deceleration traps will work only for the 31 meter target where masking is not an issue (Action Target - TCT; Savage - OM96; Shooting Ranges International - R493).

Friction traps will work for this range which requires horizontal traps, nearly flush with the ground, out to 16 meters (Capito - Granular Trap; Caswell - Gran Trap; COTS Logs, Rubber Blocks, Wax, Plastic; Range Masters - TEC; WES-SACON, and Burleburger - REGUPOL), and moderate height traps will work from 17 to 31 meters (no higher than the target) (same list plus Caswell - Lamella).

Impact traps will work from 17 to 31 meters if they are sized accordingly to avoid masking (Action Target - Thunder Ranch). These traps have the added benefits of easy maintenance in place, or because of their mobility, they are easily rotated with new traps, on and off the range, for major maintenance.

Estimating Target Receive Rates



The "Target Receive Rate" is the number of rounds which hit or nearly hit one target on one firing lane annually. You will estimate the target receive rate for the most heavily used firing lanes on a range and then use this figure to choose a bullet trap that will not require major maintenance more than once a year. In this way you may minimize the bullet traps impact on your normal range operations. Trap repairs (maintenance) take the range out of operations.

Table 2 shows three evaluation criteria under the Maintenance category: 1) Number of rounds to replacement or major refurbishment, 2) Duration of Annual Maintenance, and 3) Duration of Monthly Maintenance. The time estimates in this table assume that you will choose a bullet trap type, such that the individual traps will require replacement /refurbishment no more than once a year. You may estimate the target receive rate for your range in one of two ways: either by using estimated numbers of firers annually or by the amount of ammunition allocated and returned annually.

First, estimating target receive rates using numbers of firers:

- $(\text{number of firers each year}) / (\text{number of lanes})^* = \text{firers per year per lane.}$
- $(\text{number of firers per lane per year}) \times (\text{number of bullets each firer sends toward each target}) = \text{bullets per target}$
- $(\text{bullets per target}) \times (\text{estimated capture rate (\%)} \text{ for that target})^{**} = \text{target receive rate.}$

Second, estimating target receive rates using ammunition allocations and returns.

- $(\text{ammunition allotted for a particular range for a year}) - (\text{the ammunition returned that year}) = \text{annual number of bullets for the range}$
- $(\text{number of bullets for the range}) / (\text{number of lanes})^* = \text{bullets fired on each lane}$
- $(\text{bullets fired on each lane}) \times (\text{percentage of bullets each firer sends toward each target (e.g. 0.25 for AFF 75 meter target or 1.0 for any target on a 25 meter range)}) = \text{bullets per target}$
- $(\text{bullets per target}) \times (\text{estimated capture rate (\%)} \text{ for that target})^{**} = \text{target receive rate.}$

* To conservatively estimate the target receive rate, only spread the firers (or bullets) over the number of lanes generally used. In other words, if there are 20 firing lanes but you generally use only the first ten (from left to right), then only use 10 as your number of lanes.

****The estimated capture rate for a target is your best estimate of the number of target hits or near hits divided by the total rounds fired at this target. This capture rate is therefore a measure of the firers' accuracy generally seen on your range.**

If your estimated annual target receive rate on your range is less than 10,000 bullets, then you may consider using one of the friction traps, which requires replacement of materials after no more than 10,000 bullets. If your highest annual target receive rate exceeds 100,000 rounds, then you should consider using a deceleration trap. In between 10,000 and 100,000 bullets, either deceleration traps or specific friction traps apply (see Table 2).

Installation Considerations

You may consider installation in two phases: 1) preparing the site for bullet trap installation, and 2) the physical construction of the bullet trap(s). Preparing the site requires effort on your part, while the vendor takes responsibility for the trap construction. The following discussion describes some bullet trap installation considerations which may help you to narrow your selection of traps and smooth the trap installation process.

Site Preparation

Most trap designs (friction or deceleration) require either a level concrete or gravel pad. A gravel pad is less costly but may not be sufficient for specific traps. Deceleration traps generally require concrete pads while lamella, solid block, and granular fill traps only require a level graded surface. You may also consider the schedule implications of a concrete pad; concrete requires approximately twenty-eight days to cure before bullet trap installation.

Carefully prepare the underlying soil before installing either a concrete or gravel base for several reasons: 1) to allow adequate drainage; 2) to prevent uneven settling; and 3) to allow for bullet trap anchoring so that the trap can withstand winds and rains without moving or toppling. Design areas around the traps to direct the water in such a way as to minimize erosion.

Some traps require significant range recontouring. For example, deceleration traps may require regrading of the entire range to provide a continuous structure. As a cost saving measure, one range manager using this type of trap divided the trap into several sections across the front of the range. Concealment of a trap base will require the same type of surface contouring required to hide target coffins now on the range.

Space Considerations for Traps

Plan for sufficient space around bullet traps so that they may undergo routine maintenance and lead recycling. Place the traps so that they do not protrude into the line of targets, and allow room for easy replacement of both disposable targets and target frames. Maximize the distance between the target frame and the front of the deceleration trap so that most paper, cardboard, wood and plastic particles blown backward by the bullet will not enter the trap. Alternatively, you may place targets directly against the front of most friction traps because these traps do not use deflector plates. In fact, you may place modular (or block) type friction traps directly against the front of the target coffin as a protective barrier (see figures 1 through 4). If you currently mow the grass on your range as a part of regular maintenance, allow enough space around and behind the trap to allow access for mowing equipment.

Allow sufficient space around your trap for both maintenance checks and major refurbishment. All parts of the trap should be accessible for inspection to check for rust, integrity of welds, and reasonable replacement of worn components. Access must allow for approach to the trap from in front, behind, and beneath (where applicable).

Bullet recycling also requires some maneuvering space. Granular traps must have 1.5 meters of working space in front to harvest the out-flow of fill material and bullets. Some vertical granular traps require a ladder for access to the top of the trap to refill granular material (Trap Types, specifically page 13). For deceleration traps, the worker must tighten wingnuts on either side of the bucket to attach it tightly. Bullet removal for most traps also requires enough space to get a large collection vessel, such as a 55 gallon drum, close to the trap.

Utilities

Some traps which offer special features require electrical power. Traps may require electricity when: 1) an agitator is needed to shake bullets down into a collection bin, or 2) a two stage vacuum removes and reloads granular fill. Traps which require continuous electricity need permanently installed electric utility wires, whereas you may use a portable generator when recycling granular fill or bullet debris with a portable vacuum system.

Bullet traps do not require water for normal operation, but some deceleration traps use an oil based liquid or an internal air filtration system; both require continuous electricity to operate their pumping systems.

Overhead Protection from Rain & Snow

You may consider using overhead cover to prevent corrosion of both the trap parts (steel) and leaching of permeable friction traps with embedded bullet fragments (lead). The steel components on many bullet traps have the potential to corrode, and therefore, increase the required maintenance. Steel generally comprises the bolts and connecting brackets for even wood framed bullet traps. Lead corrosion (bullets) poses an additional concern for permeable friction designs, such as blocks with recovery channels or lamella designs. These permeable block designs allow bullets to remain exposed to overhead precipitation and have the potential for lead corrosion and subsequent leakage.

Traps which require electrically driven pump systems may also require overhead protection. This addition will increase the cost, the size of the trap, and the ability to see down range targets (see Life Cycle Cost - page 41, Installation Considerations - page 37, and Trap Placement Strategies - page 43).

**Tracer Rounds
& Risk of
Igniting Trap
Materials**

Consider whether you will shoot tracer rounds at your bullet trap because some bullet traps are flammable. Flammable wood or rubber comprise part or all of some traps. The frame for the boxed granular and lamella friction traps is wood. The granules themselves in the boxed granular trap constitute a fire hazard, although manufacturers suggest that the lack of oxygen inside the pile of fill matter will eventually extinguish a fire.

Estimating Capital & Life Cycle Costs

The total dollar cost for a bullet trap on your range includes both the capital costs (one time initial costs) and recurring costs (over the lifetime of the traps). Table 4, below, shows two high-level categories for capital costs (site preparation and installation) and two categories of recurring costs (maintenance and disposal). You may use this table as a template to estimate the cost of a bullet trap as applied to your range. You can either estimate with previous construction projects on your ranges (e.g. target coffins etc.) or call contractors for estimates.

Within the Installation costs, consider the following cost items: materials, labor, and overhead protection construction (materials and labor). When requesting estimates from manufacturers, inquire whether their dollar figures include these items.

Within the Maintenance category, consider the following cost items: vacuum equipment, personnel protective equipment (dust masks and gloves at a minimum), 55 gallon drums for collection of spent rounds destined for recycling, manhours for both monthly maintenance checks and for major maintenance/ parts replacement, and materials (or parts). You may consider having some replacement parts included in the capital cost, so that no extended interruptions occur for range operations while parts are "on order."

Most friction traps will annually have some material which no longer functions as intended (rubber or SACON), which for cost estimating purposes we will consider as "spent." This spent material may not pass TCLP (Toxicity Characteristic Leaching Procedure) and therefore be considered as hazardous waste. The TCLP limit for lead is 5 ppm. Within disposal costs, try to estimate the annual amount (tons) of spent hazardous material removed from the trap (excluding the bullets which you may be able to send to a recycler and receive funds back) and multiply this tonnage by a dollar figure of approximately 450 dollars for a unit disposal cost depending on the local rate for hazardous materials disposal. The \$450/ton estimate is based upon the actual disposal cost for spent rubber used at Fort Drum, New York. Add to this unit disposal figure, the cost of transporting the material to a disposal facility. We estimated \$400 to haul a 10 ton shipment, which assumed a 200 mile distance to the disposal facility. Multiply this annual cost by the expected lifetime (years) of the trap. Add to this annual disposal figure the cost to dispose of the entire trap after its useful life. Some material will be classified as hazardous waste and some may not. You may consider inquiring with the manufacturer about the expected lifetime of the trap.

Table 4 - Template for Estimating Bullet Trap Life Cycle Cost

Life Cycle Costs	High Level Category	Low Level Category	Cost
Capital Costs	Site Preparation	Grading/Clearing (time & dollars) Platform (gravel or concrete)	
	Installation	Manufacturer material cost Labor cost per unit Overhead protection	
Recurring Costs	Maintenance	Material cost per year Labor cost per year	
	Disposal	Annual disposal cost (\$/ton) including transportation Final disposal (entire trap)	

Trap Placement Strategies

Several factors effect the placement of traps on your range: bullet trajectories, the angle of incidence required by the specific trap for safety (no ricochets), ability to site down range target (masking), and avoiding both soil and target coffin erosion. The discussion below focuses on masking and avoiding erosion, but you may consider discussing bullet trajectories and allowable angles of incidence with the manufacturer before purchasing a trap.

Masking

Due to their height and width, certain deceleration traps and boxed friction traps may mask down range targets in a firing lane. One method to test for masking is to construct a portable wooden or cardboard silhouette, shaped like the front area of the trap, including overhead protection. You may bring this silhouette to the range and raise it behind the individual targets to verify clearance for the shooter. Alternatively, you may ask the manufacturer whether they are able to alter the bullet trap dimensions to suit your needs.

Avoiding Soil & Target Coffin Erosion

Consider placing low lying, modular friction traps, over the most heavily beaten soil areas near target coffins to mitigate accelerated erosion and avoid future land rehabilitation. Figures 1 through 4 show the general beaten zone areas where bullet impacts are expected. You can place these traps in a tile-like format, so that as individual blocks fill up, you only replace these blocks, rather than tearing down a large unit that only has a small incised area. Some installations currently use logs in front of target coffins. Friction traps function similarly and have the potential for full body coloration, so that as the friction material gets worn off, target coffins remain camouflaged.

Discussions with Manufacturers



Previous sections of this report identify important issues regarding preliminary discussions with manufacturers.

Those and some others issue are listed below in a checklist fashion so that you may use this list to take notes during your discussions.

Masking

1. Can the trap be sized/shaped to my specifications?
2. For block traps, can they be manufactured in modular form?
3. Do blocks (friction traps) fit into a frame, and if so, will you supply this frame?

Camouflage

1. Can the traps be colored (surface or full body) or otherwise camouflaged to blend-in with the environment?

Installation

1. Will you provide all the materials, manpower and equipment for installation?
2. Will you assemble large portions of the traps nearby, on-site, and then move the pre-assembled units on to the range OR use the range for full assembly.
3. When will you test the traps to determine that they meet performance specifications?
4. How long will installation and performance testing take?
5. Do I need a concrete base for the trap, and if so, what are the dimensions and loading requirements? Are there any specific anchoring hardware requirements within the concrete?
6. How much clearance space do I need around each trap for installation and maintenance?
7. Are there any scheduling requirements that I should know about? Tell me about curing times for block traps. Tell me about the order in which the site preparation and installation will take place (for example: base construction by installation, frame construction by manufacturer, trap installation, and trap testing).

Cost

1. Is installation included in your quoted price (parts and labor)? Please provide a breakdown of these costs.
2. Are any replacement parts included in your quoted price?
3. Does the price depend on how many units I purchase? If so, please provide quotes for purchasing various unit quantities.

Maintenance

1. What is the expected lifetime of this type of trap?
2. How many rounds will the trap take before the trap requires major maintenance/ part replacement and removal of "spent trap material?"
3. Please provide information regarding the amount of spent material removed during major maintenance.
4. Please provide information regarding historical TCLP results for this removed spent material and costs associated with disposal.
5. Warrantee Information: Do you guarantee that the trap performs as specified (catch bullets up to the size claimed) and will you replace all or part of the trap at no extra charge if portions of the trap do not perform as specified?
6. May I have a list of previous purchasers (names and phone numbers)?

Maintaining Your Trap

Both bullet traps and areas surrounding bullet traps require maintenance. Bullet traps require regular maintenance to keep them in working order, including bullet removal and recycling. The areas surrounding these traps also need care and attention to insure that traps provide pollution and erosion prevention. Establish a regular maintenance program including a maintenance logbook. Use the checklist below in combination with the manufacturer's recommended maintenance program as a guide for establishing weekly, monthly, or semiannual bullet trap surveillance and maintenance. The pace of these checks depends on the actual target receive rate for your range. In other words, if you use the traps heavily, then consider weekly maintenance checks, but if you only fire a few thousand rounds into these traps annually, then monthly or semiannual checks may suffice.

Maintenance Checklist

Name: _____ Date: _____ Range: _____

Support Structures

Does frame have any splits or cuts?
Does the frame or trap show any unusual rust or wear? If so where?
Does the trap attach firmly to the base? Has the trap or base shifted?
Is the trap/base level?

Action: Make repairs in accordance with manufacturer's instructions.

Erosion and Pollution Prevention Considerations

Do you see signs of standing water near the trap?
Do you see any signs of erosion (rills or gullies)?
Do you see signs that rounds are missing the trap (beaten zones)?

Action: Document problems; regrade or reposition trap/firing point.

Trap Structure Performance

For deceleration traps, do you see any target debris in or near the deflection plates?

For metal traps or traps with metal components:

Are welds secure?

Are bolts secure?

Are there any signs of rust or wear? If so, where?

For friction traps:

Do you see signs of the bullet trap friction material away from the trap? If so, then describe the distance and the materials' size and shape.

Are there any gaps between the modules of the friction material? If so, where are the gaps and what is inside the gaps?

Action: Inspect and clean (remove target debris); make required repairs in accordance with manufacturer's instructions.

Bullet Recycling

Are bullet recovery receptacles 1/4, 1/2, 3/4, or completely full?

Action: Collect bullets when receptacles are 1/2 - 3/4 full.

Actions Taken

Document in maintenance logbook the actions taken on this range, including the lane number, and target distance.

Standard Operating Procedures

Establish Standard Operating Procedures (SOPs) for bullet recovery/recycling, for friction trap material recovery, recycling, or disposal and for maintenance. This standard operating procedure should include the materials and equipment necessary for recovering and recycling materials, any paperwork necessary for transporting recovered material to the recycler or disposal facility, and a Safety and Health Plan for this recovery process. Establish this Safety and Health Plan in accordance with applicable sections of the Code of Federal regulations (29 CFR1910.120). This section of the Code of Federal Regulations specifies the process for establishing a health and safety program and includes requirements for the allowable level of worker exposure during the handling of hazardous materials; bullets and bullet fragments contain lead, which is considered a hazardous material. These SOPs will be assessed by the Site Industrial Hygenist for compliance with CFR requirements for personnel exposure.

Conclusions

Many types of bullet traps exist. This guide provides six basic steps for choosing a bullet trap for your individual range. First, estimate the potential annual target receive rates (number of rounds per target per year). Second, consider bullet trap installation requirements including: site preparation, space and structural requirements, utility requirements, overhead protection, and the trap's compatibility with tracer rounds. Third, consider not only the capital investment for these traps, but the life cycle cost. Fourth, if you now have only one or two trap options remaining after considering range operations, space/ structural requirements, and cost, then consider whether the firer can sight down range targets given various trap placement strategies. Fifth, consider phoning the manufacturer and discussing the detailed manufacturing and installation arrangements as well as the warrantee(s) associated with the trap(s) you want to purchase. Lastly, consider bullet trap maintenance after installation, including: arranging for bullet recycling, rotating sections for modular traps, arranging for regular maintenance, and removing / replacing / disposing of unrecyclable portions of the trap.

Appendix A - References

Heath, J.C., L. Karr, V. Novstrup, B. Nelson, S.K. Ong, P. Aggarwal, J. Means, S. Pomeroy, and S. Clark, 1991, Environmental Effects of Small Arms Firing Ranges, *Naval Civil Engineering Laboratory Technical Note*, Port Hueneme, CA, 57 pp.

U.S. Army, February 1992. *Training Ranges*, Department of the Army Training Circular 25-8.

U.S. Army Environmental Center, November 1996. *Bullet Trap Feasibility Assessment*, SFIM-AEC-ET-CR96195.

U.S. Army Environmental Center, March 1996. *Bullet Trap Feasibility Assessment and Implementation Plan Technology Identification Report*, SFIM-AEC-ET-CR-96005.

U.S. Army Environmental Center, April 1996. *Bullet Trap Feasibility Assessment and Implementation Plan, Evaluation Criteria Report*, SFIM-AEC-ET-CR-96142.

Appendix B - Manufacturer Addresses & Phone Numbers

Action Target
P.O. Box 636
Provo, UT 84603
Phone: 801-377-8033; FAX: 801-377-8096

Ballistic Technology Inc.
1041 Avenue Road, Suite Four
Toronto, Ontario M5N2C5
Phone: 416-932-0208; FAX: 416-932-0460

Berleburger Schaumstoffwerk GMBH
P.O. Box 1180
5920 Bad Berleberg, Germany
US Distributor: Tennek, Inc.
972 Tapadevo Road
Bailey, CO 80421
Phone: 303-838-0922; FAX: 303-838-0924

Caswell International Corp.
1221 Marshall St. NE
Minneapolis, MN 55413
Phone: 612-379-2000; FAX: 612-379-2367

Capito & Assenmacher
44319 Dortmund Wichkede
44311 Dortmund
Germany
Phone: 0231 331012-0; FAX: 21925

Range Masters, Inc.
199 Coon Rapids Blvd.
Suite 304
Coon Rapids, MN 55433
Phone: 612-357-4104; FAX: 612-357-4105

Savage Range Systems, Inc.
100 Springdale Rd.
Westfield, MA 01085
Phone: 413-568-7001; FAX: 413-562-7764

Societa FRA.SA
Rome - Via del Giordano, 44
Italy
Phone: 59-25-560 or 59-11-936; FAX: 59-24-175

Shooting Ranges International, Inc.
3030 S. Valley View Blvd.
Las Vegas, NV 89102
Phone: 702-876-5444; FAX: 702-876-0327

U. S. Army Corps of Engineers
Waterways Experiment Station
Structures Laboratory, Attn: CEWES-SC-EM
3909 Halls Ferry Road
Vicksburg, MS 39180-6199
Attn: Dr. Philip Malone
601-634-3960