

AFWAL-TM-88-182-FIBE

19970623 124



EFFECT OF THE PLASTIC BEAD BLASTING PAINT
REMOVAL PROCESS ON THE FATIGUE LIVES OF
THIN SKIN MATERIALS

Howard J. Storr, Jr., 2nd Lt, USAF

May 1988

Approved for public release; distribution is unlimited

DTIC QUALITY INSPECTED 4

FLIGHT DYNAMICS LABORATORY
AIR FORCE WRIGHT AERONAUTICAL LABORATORIES
WRIGHT-PATTERSON AIR FORCE BASE, OHIO 45433

REPORT DOCUMENTATION PAGE

Form Approved
OMB No. 0704-0188

Public reporting burden for this collection of information is estimated to average 1 hour per response, including the time for reviewing instructions, searching existing data sources, gathering and maintaining the data needed, and completing and reviewing the collection of information. Send comments regarding this burden estimate or any other aspect of this collection of information, including suggestions for reducing this burden, to Washington Headquarters Services, Directorate for Information Operations and Reports, 1215 Jefferson Davis Highway, Suite 1204, Arlington, VA 22202-4302, and to the Office of Management and Budget, Paperwork Reduction Project (0704-0188), Washington, DC 20503.

1. AGENCY USE ONLY (Leave blank)		2. REPORT DATE 1988		3. REPORT TYPE AND DATES COVERED FINAL 10/01/87 - 04/01/88	
4. TITLE AND SUBTITLE EFFECT OF PLASTIC BEAD BLASTING PAINT REMOVAL PROCESS ON THE FATIGUE LIVES OF THIN SKIN MATERIALS				5. FUNDING NUMBERS PR 2401 TA 01 WU 779	
6. AUTHOR(S) HOWARD J. STORR, JR					
7. PERFORMING ORGANIZATION NAME(S) AND ADDRESS(ES)				8. PERFORMING ORGANIZATION REPORT NUMBER	
9. SPONSORING / MONITORING AGENCY NAME(S) AND ADDRESS(ES) FLIGHT DYNAMICS LABORATORY AIR FORCE WRIGHT AERONAUTICAL LABORATORIES WRIGHT-PATTERSON AFB, OHIO 45433 POC: Dr Clare A. Paul, WL/FIBE, (937) 255-6104				10. SPONSORING / MONITORING AGENCY REPORT NUMBER AFWAL-TM-88-182-FIBE	
11. SUPPLEMENTARY NOTES					
12a. DISTRIBUTION / AVAILABILITY STATEMENT APPROVED FOR PUBLIC RELEASE: DISTRIBUTION UNLIMITED				12b. DISTRIBUTION CODE	
13. ABSTRACT (Maximum 200 words) Room temperature fatigue tests were conducted on unblasted and plastic bead blasted 2024-T6H24 aluminum (thickness = 0.024 inch, long transverse grain direction), 2024-T6H24 aluminum (thickness = 0.016 inch, longitudinal grain direction) and AZ31B-H24 magnesium (thickness = 0.032 inch, longitudinal grain direction) for unblasted, long transverse grain direction for plastic bead blasted). For the 0.024 inch thick aluminum (case 1) material, unblasted, type I plastic bead blasted, and type II plastic bead blasted specimens were tested. For the 0.016 inch thick aluminum (case 2) and the magnesium (case 3) materials, unblasted and type I plastic bead blasted specimens were tested. ("Type I" and "type II" describe two different types of plastic beads). In cases 1 and 2, the Wilcoxon Rank Sum Test was used to compare the fatigue lives of the unblasted and plastic bead blasted specimens. In case 1, type I plastic bead blasting was shown to have a detrimental effect on fatigue life. Statistical evidence was insufficient to reject the null hypothesis for type II plastic bead blasting. In case 2, type I plastic bead blasting was shown to have a detrimental effect on fatigue life. In case 3, no comparison was made because the unblasted specimens were for the longitudinal grain direction and the blasted specimens were for the long transverse grain direction.					
14. SUBJECT TERMS				15. NUMBER OF PAGES 24	
				16. PRICE CODE	
17. SECURITY CLASSIFICATION OF REPORT U		18. SECURITY CLASSIFICATION OF THIS PAGE U		19. SECURITY CLASSIFICATION OF ABSTRACT U	
				20. LIMITATION OF ABSTRACT SAR	

FOREWORD

This report describes an in-house effort conducted under Project 2401, "Structures," Task 240101, "Structural Integrity for Military Aerospace Vehicles," Work Unit 24010179, "Life Analysis and Design Methods for Aerospace Structures."

The work was performed by the Structural Integrity Branch, Structures Division, Flight Dynamics Laboratory, Air Force Wright Aeronautical Laboratories (AFWAL/FIBE), Wright-Patterson Air Force Base, Ohio. The period covered by the research is October 1987 through April 1988.

The in-house effort was conducted by 2nd Lt Howard J. Storr, Jr., in support of the San Antonio Air Logistic Center (SA-ALC/MMEIM/MMSRA). The Center furnished the test specimens to AFWAL/FIBE.

Acknowledgement is due to the members of the Fatigue, Fracture and Reliability Group (AFWAL/FIBEC) for their suggestions and for reviewing this report.

This technical memorandum has been reviewed and is approved for publication.

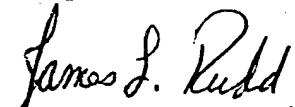
JAMES L. RUDD, Tech Mgr
Fatigue, Fracture & Reliability Gp
Structural Integrity Branch

DONALD B. PAUL, Chief
Structural Integrity Branch
Structures Division

ABSTRACT

Room temperature fatigue tests were conducted on unblasted and plastic bead blasted 2024-T6H24 aluminum (thickness = 0.024 inch, long transverse grain direction), 2024-T6H24 aluminum (thickness = 0.016 inch, longitudinal grain direction) and AZ31B-H24 magnesium (thickness = 0.032 inch, longitudinal grain direction for unblasted, long transverse grain direction for plastic bead blasted). For the 0.024 inch thick aluminum (case 1) material, unblasted, type I plastic bead blasted, and type II plastic bead blasted specimens were tested. For the 0.016 inch thick aluminum (case 2) and the magnesium (case 3) materials, unblasted and type I plastic bead blasted specimens were tested. ("Type I" and "type II" describe two different types of plastic beads). In cases 1 and 2, the Wilcoxon Rank Sum Test was used to compare the fatigue lives of the unblasted and plastic bead blasted specimens. In case 1, type I plastic bead blasting was shown to have a detrimental effect on fatigue life. Statistical evidence was insufficient to reject the null hypothesis for type II plastic bead blasting. In case 2, type I plastic bead blasting was shown to have a detrimental effect on fatigue life. In case 3, no comparison was made because the unblasted specimens were for the longitudinal grain direction and the blasted specimens were for the long transverse grain direction.

TABLE OF CONTENTS

<u>SECTION</u>	<u>PAGE</u>
I. INTRODUCTION	1
II. TEST PROGRAM	2
III. RESULTS AND DISCUSSION	6
IV. CONCLUSIONS	16
V. REFERENCES	17

LIST OF FIGURES

<u>FIGURE</u>	<u>PAGE</u>
1. Aircraft Component Manufactured for Plastic Bead Blasting	3
2. Fatigue Test Specimen	4
3. Fatigue Data for 2024-T6H24 (Thickness = 0.024 inch) Unblasted, Type I, Type II	11
4. Fatigue Data for 2024-T6H24 (Thickness = 0.016 inch) Unblasted, Type I	12
5. Fatigue Data for AZ31B-H24, Unblasted	14
6. Fatigue Data for AZ31B-H24, Type I	15

LIST OF TABLES

<u>TABLE</u>	<u>PAGE</u>
1. Test Matrix	2
2. Fatigue Data for 2024-T6H24 (Thickness = 0.024 inch) Unblasted	5
3. Fatigue Data for 2024-T6H24 (Thickness = 0.016 inch) Unblasted	5
4. Fatigue Data for 2024-T6H24 (Thickness = 0.024 inch) Type I	8
5. Fatigue Data for 2024-T6H24 (Thickness = 0.024 inch) Type II	9
6. Fatigue Data for 2024-T6H24 (Thickness = 0.016 inch) Type I	10
7. Comparisons Made Using the Wilcoxon Rank Sum Test	13
8. Fatigue Data for AZ31B-H24, Unblasted	14
9. Fatigue Data for AZ31B-H24, Type I	15

NOMENCLATURE

Type I	blasted w/type I media
Type II	blasted w/type II media
W,W*	statistical parameters in the Wilcoxon Rank Sum Test
L	longitudinal direction; parallel to the rolling direction or strain axis
LT	long transverse direction; perpendicular to the rolling direction or strain axis
Al	aluminum
Mg	magnesium
ksi	kips per square inch (1 kip = 1,000 lbs)
R	minimum-to-maximum stress amplitude ratio
S	stress
N	life cycles

SECTION I

INTRODUCTION

Traditionally, paint has been removed from weapon systems by chemical stripping. This method is labor intensive and requires the use of strongly activated chemicals. In addition, it produces large quantities of hazardous waste that must be properly disposed of. Therefore, Plastic Bead Blasting (PBB) has received considerable attention as a possible alternative to chemical stripping.

Initially, the PBB process worked well with skins of thicknesses greater than or equal to 0.071 inch. With thin skins (< 0.071 inch), however, the process resulted in severe fatigue life degradation[1].

Recently, significant progress has been made in minimizing the reduction in fatigue lives of thin skin materials due to the PBB paint removal process. Parametric studies conducted by Battelle Columbus Division have resulted in the optimum values of bead size and hardness, nozzle pressure, distance to the target, and angle of attack.

The procedures developed by Battelle will be used in a blasting facility under construction at Randolph AFB TX. The purpose of this technical memorandum (TM) is to document a study of the fatigue lives of thin skin materials blasted using these procedures and the equipment to be shipped to the Randolph AFB facility. The thin skin materials are representative of the thinnest skins on T-37 and T-38 aircraft. The objective of this study was to determine whether or not the fatigue lives of the plastic bead blasted materials were significantly different than the fatigue lives of the unblasted materials.

SECTION II

TEST PROGRAM

An aircraft component was fabricated as shown in Figure 1. The skins were fastened to the component, either plastic bead blasted or left unblasted, then removed. The flat skin sections were then machined into test specimens (see figure 2). The test matrix is presented in Table 1.

ALLOY	THICKNESS (inch)	GRAIN DIRECTION	BEAD BLAST CONDITION	NUMBER OF SPECIMENS
AL 2024-T6H24	.024	LT	unblasted	7
AL 2024-T6H24	.024	LT	type I media	11
AL 2024-T6H24	.024	LT	type II media	11
AL 2024-T6H24	.016	L	unblasted	7
AL 2024-T6H24	.016	L	type I media	11
Mg AZ31B-H24	.032	L	unblasted	6
Mg AZ31B-H24	.032	LT	type I media	11

Table 1. Test Matrix

Room temperature, constant amplitude fatigue tests ($R = 0.3$) were conducted on the aluminum specimens at load levels sufficient to get approximately one million cycles on the unblasted specimens. For the 0.024 inch thick aluminum (Table 2), a maximum stress of 32 ksi was sufficient to get approximately one million cycles on the unblasted specimens. For the 0.016 inch thick aluminum (Table 3), a maximum stress of 34 ksi was used. An R ratio of 0.3 was selected because Battelle used $R = 0.3$ in their initial characterization study of 0.016 and 0.032 inch thick materials[1].

Table 1 shows that the grain direction of the magnesium specimens was not consistent between the unblasted and plastic bead blasted specimens. Therefore, a fatigue life comparison between the unblasted and plastic bead blasted specimens could not be made. However, S-N data were generated for the magnesium material and are presented in Section III. The magnesium specimens were also tested at an R ratio of 0.3.

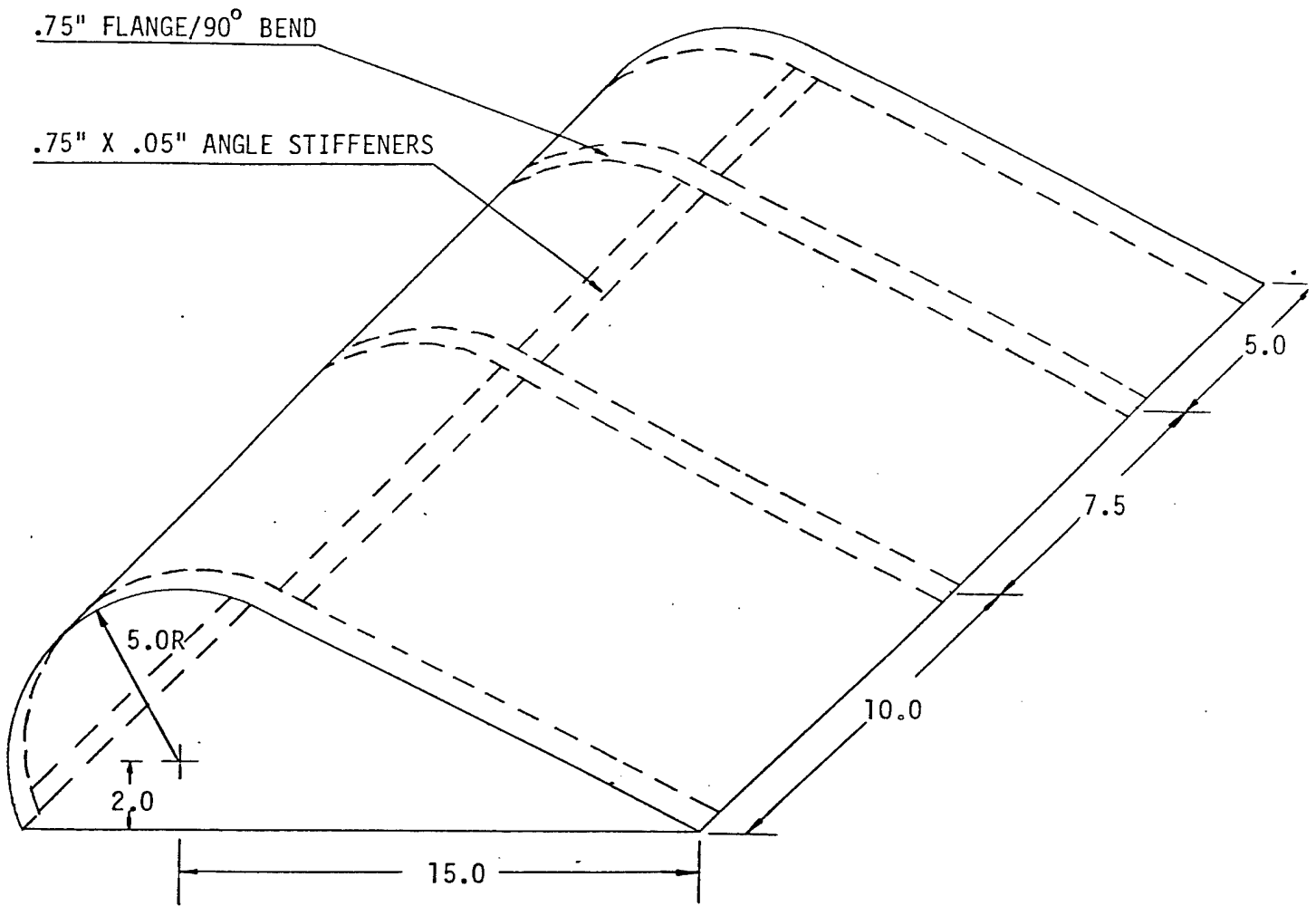

ALL DIMENSIONS IN INCHES/SCALE 1:5

TEST PANEL ATTACHED TO FRAMES AND STIFFENERS WITH MS20470-5 RIVETS

Figure 1. Aircraft Component Manufactured for Plastic Bead Blasting

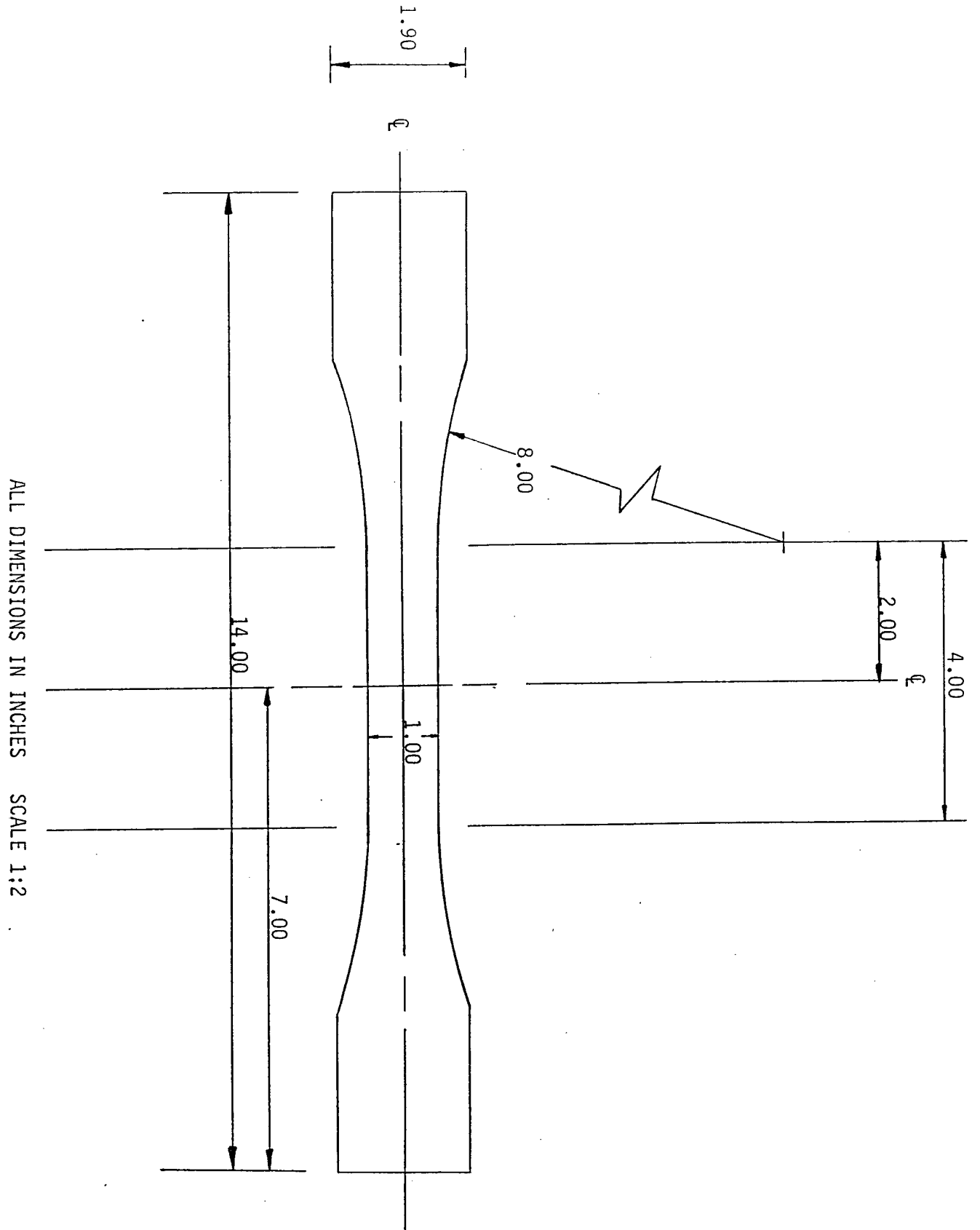

Figure 2. Fatigue Test Specimen

SPECIMEN NUMBER	MAX STRESS (ksi)	CYCLES TO FAILURE
1	47	140,400
2	42	247,500
3	35	404,700
4	32	1,002,300
5	32	1,099,990
6	32	1,136,200
7	32	1,084,600

Table 2. Fatigue Data for 2024-T6H24 (Thickness = 0.024 inch), Unblasted

SPECIMEN NUMBER	MAX STRESS (ksi)	CYCLES TO FAILURE
30	32	2,051,300
31	34	1,048,100
32	34	1,376,200
33	34	1,279,300
34	34	1,660,000
35	34	1,348,500
36	34	1,070,500

Table 3. Fatigue Data for 2024-T6H24 (Thickness = 0.016 inch), Unblasted

SECTION III

RESULTS AND DISCUSSION

The fatigue data for the unblasted aluminum specimens are presented in Tables 2 and 3. The fatigue data for the plastic bead blasted aluminum specimens are presented in Tables 4 through 6 and are shown graphically in Figures 3 and 4. The fatigue data for the magnesium specimens are presented in Tables 8 and 9 and are shown graphically in Figures 5 and 6. In figures 3,4,5 and 6, "stress" = maximum stress.

Initially, an attempt was made to determine the effect of plastic bead blasting on the fatigue lives of the aluminum specimens by plotting the mean fatigue lives \pm one standard deviation for the unblasted and plastic bead blasted specimens. It was decided, however, that this statistical comparison was inconclusive due to the difference in sample sizes and the assumed normal distribution of the data. Therefore, a nonparametric test (i.e., independent of assumed distribution type) was conducted to determine the effect of plastic bead blasting on the fatigue lives of the aluminum specimens.

Three comparisons were made using the Wilcoxon Rank Sum Test[2] as shown in Table 7. For each comparison, W was calculated. Then, using the large sample approximation, W^* was calculated and the probability of calculating that value of W^* for identical groups of specimens was retrieved from table A1 in reference [2]. Referring to Table 7, the results are summarized in the following paragraphs.

Comparison 1. ($W = 69$, $W^* = 2.48$) If both groups of specimens were identical, the calculated value for W^* could occur by chance about 7 out of 1000 times. This is highly unlikely. Therefore, there is strong statistical evidence of a treatment effect and the null hypothesis of no treatment effect is rejected. Referring to Figure 3, it is clear that the "treatment effect" is a degradation in mean fatigue life.

Comparison 2. ($W = 80$, $W^* = 1.05$) If both groups of specimens were identical, the calculated value for W^* could occur by chance about 15 out of 100 times. Therefore, there is insufficient statistical evidence to reject the null hypothesis.

Comparison 3. ($W = 78$, $W^* = 2.11$) If both groups of specimens were identical, the calculated value for W^* could occur by chance about 2 out of 100 times. Therefore, there is statistical evidence that there is a treatment effect and the null hypothesis is rejected. Referring to Figure 4, it is clear that the "treatment effect" is a degradation in mean fatigue life.

In the three comparisons, the probabilities were compared to an assumed level of significance of 0.02 (2 out of 100 times). Based on this level of significance, it was concluded that there was a treatment effect in comparisons 1 and 3. However nothing was said about whether or not the treatment effect was acceptable. The San Antonio Air Logistics Center is familiar with the applications of the aluminum and should, therefore, make that decision.

The center can choose any level of significance it feels appropriate for a particular application.

The PBB process also appears to increase the scatter in the aluminum data. Until the scatter is characterized, one must pay attention to the low end fatigue data.

SPECIMEN NUMBER	MAX STRESS (ksi)	CYCLES TO FAILURE
8	32	705,500
9	32	917,400
10	32	867,700
11	32	800,800
12	32	573,600
13	32	1,058,500
14	32	1,063,500
15	32	734,600
16	32	681,100
17	32	1,006,700
18	32	694,300

Table 4. Fatigue Data for 2024-T6H24 (Thickness = 0.024 inch), Type I

SPECIMEN NUMBER	MAX STRESS (ksi)	CYCLES TO FAILURE
19	32	932,600
20	32	919,000
21	32	1,214,300
22	32	786,600
23	32	1,019,100
24	32	1,054,100
25	32	1,393,700
26	32	482,300
27	32	591,600
28	32	987,700
29	32	1,729,700

Table 5. Fatigue Data for 2024-T6H24 (Thickness = 0.024 inch), Type II

SPECIMEN NUMBER	MAX STRESS (ksi)	CYCLES TO FAILURE
37	34	1,397,300
38	34	714,300
39	34	858,800
40	34	911,100
41	34	1,109,500
42	34	1,079,100
43	34	1,250,800
44	34	1,050,600
45	34	257,300
46	34	708,600
47	34	926,600

Table 6. Fatigue Data for 2024-T6H24 (Thickness = 0.016 inch), Type I

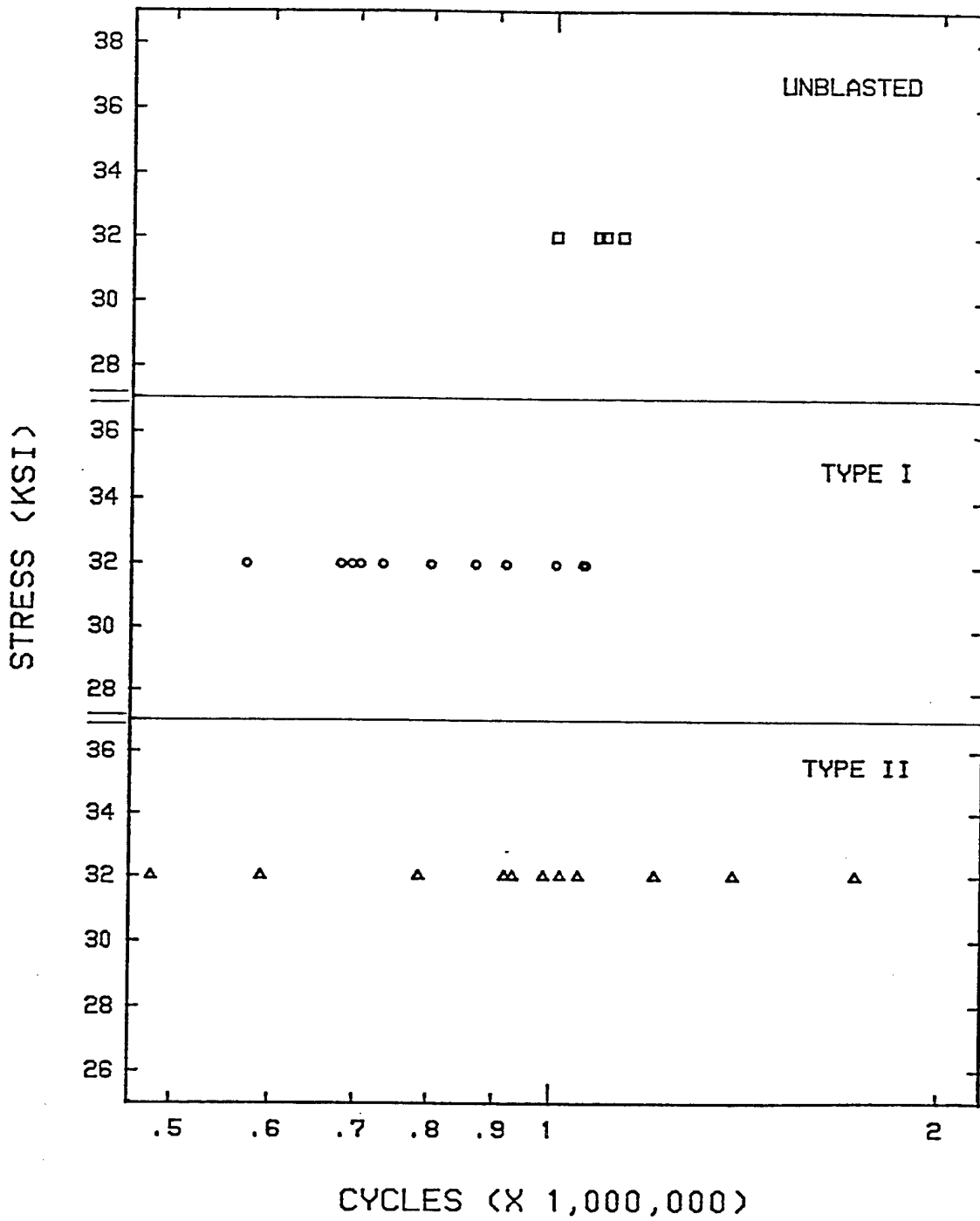

Figure 3. Fatigue Data for 2024-T6H24 (Thickness = 0.024 inch)
Unblasted, Type I, Type II

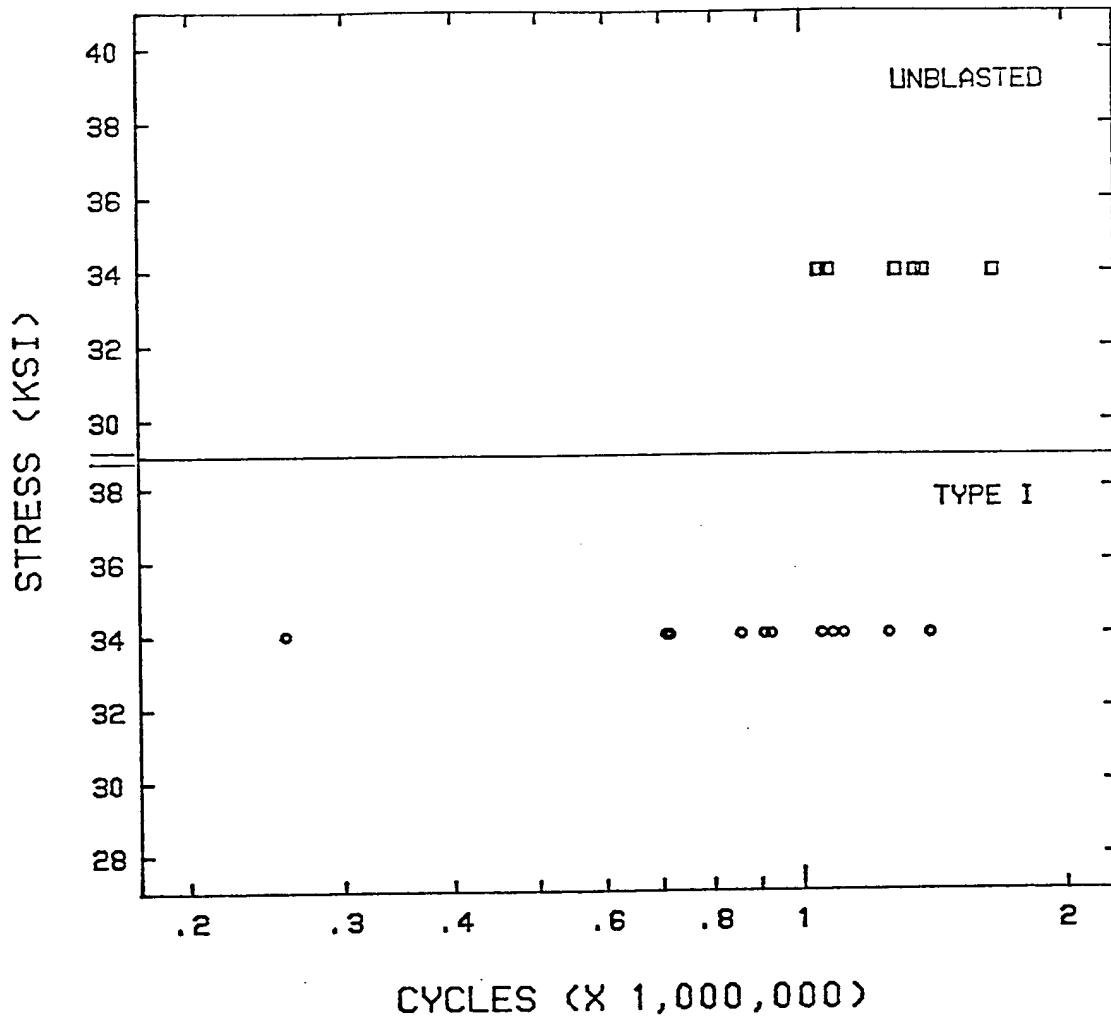

Figure 4. Fatigue Data for 2024-T6H24 (Thickness = 0.016 inch)
Unblasted, Type I

COMPARISON NUMBER	MATERIAL	THICKNESS	GRAIN DIR.	COMPARISON	W*	PROBABILITY
1	2024-T6H24	0.024	LT	unblasted vs. type I	2.48	0.0066
2	2024-T6H24	0.024	LT	unblasted vs. type II	1.05	0.1469
3	2024-T6H24	0.016	L	unblasted vs. type I	2.11	0.0174

Table 7. Comparisons Made Using the Wilcoxon Rank Sum Test

SPECIMEN NUMBER	MAX STRESS (ksi)	CYCLES TO FAILURE
48	22	2,326,000+
49	25	2,324,000+
50	30	4,190
51	27	2,230
52	27	4,470
53	25	3,103,000+

+ TEST WAS STOPPED BEFORE SPECIMEN FAILED

Table 8. Fatigue Data for AZ31B-H24, Unblasted

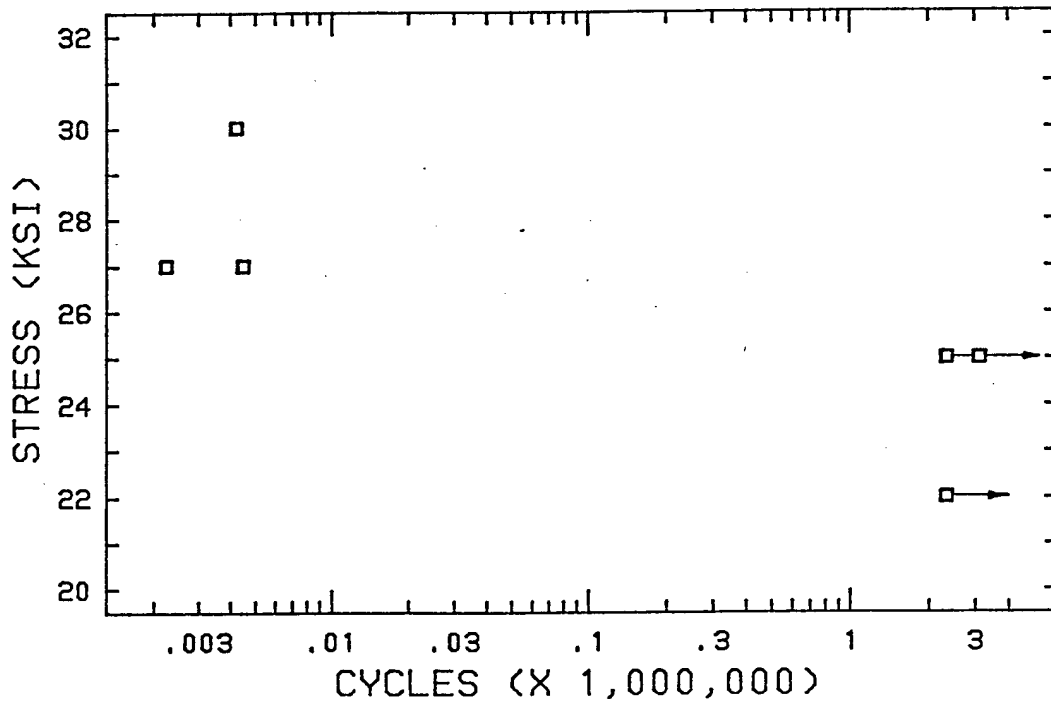

Figure 5. Fatigue Data for AZ31B-H24, Unblasted

SPECIMEN NUMBER	MAX STRESS (ksi)	CYCLES TO FAILURE
54	25	86,300
55	22	149,400
56	22	152,000
57	20	156,300
58	20	140,400
59	18	187,400
60	18	1,159,700
61	18	2,101,900
62	18	190,300
63	18	180,800
64	16	3,293,000+

Table 9. Fatigue Data for AZ31B-H24, Type I

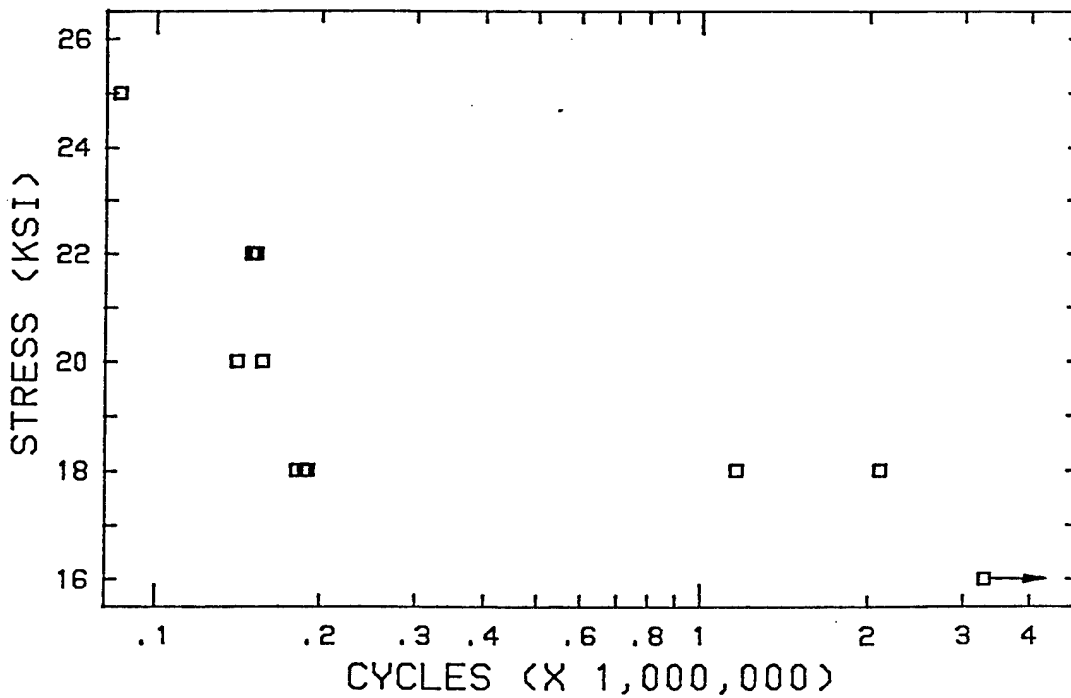

Figure 6. Fatigue Data for AZ31B-H24, Type I

SECTION IV

CONCLUSIONS

The Wilcoxon Rank Sum Test was used to compare the fatigue lives of the unblasted and plastic bead blasted 2024-T6H24 aluminum specimens. For the 0.024 inch thick, long transverse grain direction specimens, (1) type I plastic bead blasting was shown to have a detrimental effect on fatigue life and (2) statistical evidence was insufficient to reject the null hypothesis for type II plastic bead blasting. For the 0.016 inch thick, longitudinal grain direction specimens, type I plastic bead blasting was shown to have a detrimental effect on fatigue life. The San Antonio Air Logistics Center is familiar with the applications of the aluminum and should, therefore, decide whether or not the degradations in fatigue lives are acceptable.

The PBB paint removal process also appears to increase the scatter in the aluminum data. However, the scatter was not addressed in this technical memorandum. Until the scatter is characterized, one must pay attention to the low end fatigue data.

The difference in grain directions between the unblasted and plastic bead blasted AZ31B-H24 magnesium specimens prohibits the reporting of any general conclusions for the magnesium.

SECTION V

REFERENCES

1. Deel, O., Galliher, R. and Taylor, G., "Plastic Bead Blast Materials Characterization Study," for Air Force Corrosion Program Managers Office, Robins AFB GA, Jul 1986.
2. Hollander, M., Wolfe, D. A., "Nonparametric Statistical Methods," John Wiley and Sons, 1973