

AFIT/GLM/LAL/97J-3

SUPPLY CHAIN MANAGEMENT:  
A CASE STUDY OF USING EDI AND BAR CODE  
INFORMATION TECHNOLOGY

THESIS

Wei-Ya Wu  
Major, ROCAF  
AFIT/GLM/LAL/97J-3

Approved for public release; distribution unlimited

19970630 075

DEHS C7ALM7E JMW00000 1

The views expressed in this thesis are those of the author and do not reflect the official policy or position of neither the U.S. Government nor the R.O.C. Government.

AFIT/GLM/LAL/97J-3

SUPPLY CHAIN MANAGEMENT: A CASE STUDY OF  
USING EDI AND BAR CODE INFORMATION TECHNOLOGY

THESIS

Presented to the Faculty of the Graduate School of Logistics and Acquisition Management

of the Air Force Institute of Technology

Air University

Air Education and Training Command

In Partial Fulfillment of the Requirements for the Degree of

Master of Science in Logistics Management

Wei-Ya Wu, B.S.

Major, ROCAF

June 1997

Approved for public release; distribution unlimited

## Acknowledgments

I would like to take this opportunity to express my appreciation to those people who helped make this project possible. First, I would like to thank Maj William L. Scott, my academic and thesis advisor, not only for his help and support in my research effort, but also for introducing me to an exciting and interesting subject. Next, I am thankful to Dr. Craig Brandt, and Dr. Kevin R. Moore, for their guidance and support throughout the development of this thesis.

Finally, I would like to thank my family for helping me get through this effort. To my wife Shu-Yu for being so unselfish, understanding, and supportive this past year. To our children Chu-Hsien and Ho-Chi who always lifted my spirits and keep life in perspective.

Wei-Ya Wu

## TABLE OF CONTENTS

	Page
Acknowledgments .....	ii
List of Figures .....	ix
List of Tables .....	x
Abstract.....	
..xi	
I. Introduction.....	1
GENERAL ISSUE.....	1
BACKGROUND .....	2
Best Practices. ....	3
Efficient Consumer Response (ECR).....	3
Continuous Replenishment .....	4
Vendor Managed Inventory (VMI).....	5
PURPOSE OF RESEARCH.....	6
RESEARCH OBJECTIVES.....	6
RESEARCH QUESTIONS.....	7
METHODOLOGY .....	8
SCOPE AND LIMITATIONS .....	10
CHAPTER SUMMARY AND ORGANIZATION OF RESEARCH .....	10
II. Supply Chain Management: Information Technology .....	11

SECTION 1 - SUPPLY CHAIN MANAGEMENT (SCM).....	12
	Page
Supply Chain Integration.....	14
The Impact of Uncertainties.....	14
The Role of Partnerships.....	14
Supply Chain Management Approach.....	15
Information Technology.....	15
SECTION 2 - ELECTRONIC DATA INTERCHANGE (EDI).....	16
History of EDI.....	17
EDI Standards.....	18
Structure of EDI Transactions.....	19
EDIFACT and ASC X.12 Standards.....	19
How EDI Works.....	21
X12.5 Interchange Control Structures.....	21
X12.22 Segment Directory.....	23
EDI in Action.....	23
The Functions of EDI in Different Organizations.....	26
Customer Service.....	26
Manufacturing.....	26
Purchasing.....	26
Sale.....	27
Shipping.....	27
Evolution of EDI Standards.....	27

	Page
The Future State of EDI.....	28
 SECTION 3 - BAR CODE SYSTEM .....	 29
Bar Code Standards .....	31
Symbology Standards.....	31
Print Quality Standards .....	32
Data Content Code Standards .....	32
Labeling Standards.....	33
UPC/EAN Code.....	34
Linear Versus 2-Dimensional Bar Codes .....	34
Barcoding .....	35
Point of Sale (POS) System.....	35
The Scanner at the Point of Sale.....	37
The Data Capture of The Scanner .....	37
The Scanners .....	38
Handheld Scanner .....	39
Manual Motion .....	39
Contact Wand Scanner.....	40
Noncontact Wand Scanner .....	40
Automatic Motion.....	40
Noncoherent Light LED Scanner .....	40
CCD Scanner .....	40

	Page
LED Laser Scanner.....	41
Gas HeNe Laser Scanner.....	42
Fixed Mount Scanner.....	42
Manual Object Motion.....	42
Single Beam Lineal Scanner.....	42
Omni-Slot Scanner.....	42
Slot Scanner.....	42
Automatic Object Motion.....	43
Omni Scanner.....	43
Raster-Scan.....	43
Single Line Scanner.....	43
SECTION 4 - ELECTRONIC ORDERING SYSTEMS.....	43
System Definition.....	44
How EOS Works.....	45
Value-Added Networks (VANS).....	46
VAN Third Parties.....	49
EDI Gateways.....	49
CHAPTER SUMMARY.....	51
III. A Case Study: The Implementation of the Electronic Ordering	
Information System.....	52
CHAPTER OVERVIEW.....	52

	Page
BACKGROUND .....	52
COMPANY'S POSITIONING, ROLE, AND FUNCTIONS.....	53
Traditional Ordering Process.....	54
Early Efforts at Computerization.....	56
Linking to the External EOS System.....	56
INNOVATIONS WITH ELECTRONIC ORDERING .....	57
Barcoding, Scanning, and POS.....	57
The Standardization of the EOS Format.....	58
Information Flow.....	60
Merchandise Flow.....	62
LESSONS AND IMPLICATIONS FROM KANG KUO.....	63
Emerging SCM and QR .....	63
Information Technology - The Key Enabling Technologies.....	64
Uncertainty in Supply Chain Improved.....	65
Productivity in EDI Information Flow.....	65
New Approach - Efficient Consumer Response (ECR) .....	66
CHAPTER SUMMARY.....	67
IV. Analysis.....	67
CHAPTER OVERVIEW .....	67
RESEARCH FINDINGS .....	67
MOTIVATIONS TO IMPLEMENTATION .....	68

	Page
BENEFITS OF ELECTRONIC ORDERING .....	69
BARRIERS TO EDI IMPLEMENTATION .....	73
Lack of Corporate Interest and Understanding .....	73
Lack of Barcoding .....	74
STRATEGIES USED TO OVERCOME BARRIERS .....	74
V. Conclusion And Recommendations .....	75
RESEARCH QUESTIONS AND RESULTS .....	75
Research Question 1. ....	75
Research Question 2. ....	77
SUMMARY OF RESULTS .....	80
RECOMMENDATIONS .....	82
Vendor Managed Replenishment System(VMRS) .....	82
Crossdocking .....	83
RECOMMENDATIONS FOR FUTURE RESEARCH .....	84
SUMMARY OF RESEARCH .....	85
Bibliography.....	87
Vita .....	92

## LIST OF FIGURES

Figures

Page

1. A DESCRIPTION OF THE ASC X.12 FORMAT FOR A TYPICAL INVOICE.....	22
2. THE SAME DATA ON A TRADITIONAL PAPER INVOICE.....	23
3. INFORMATION FLOW WITH EDI .....	25
4. BAR CODE SYSTEM.....	29
5. POINT OF SALE (POS) SYSTEM .....	37
6. THE DIFFERENT TYPES OF SCANNERS .....	40
7. ELECTRONIC ORDERING SYSTEM.....	45
8. FUNCTIONS OF A THIRD-PARTY VAN.....	48
9. KANG KUO COMPANY'S SUPPLY CHAIN .....	54
10. THE KANG KUO COMPANY'S EOS & EDI SYSTEM .....	60
11. THE KANG KUO COMPANY'S INFORMATION & MERCHANDISE FLOW .....	61
12. ECR VERTICAL INTEGRATION IN SUPPLY CHAIN. ....	67
13. KANG KUO COMPANY SALES AMOUNT IN RECENT YEARS.....	70
14. THE FLOWS OF INFORMATION BETWEEN SUPPLIER AND DISTRIBUTOR IN VMRS .....	83

## LIST OF TABLES

Tables

Page

1. EXAMPLES OF ANSI ASC X.12 TRANSACTIONS .....	20
2. ANSI / UCC CROSS REFERENCE TABLE.....	33
3. BENEFITS TO ELECTRONIC ORDERING IMPLEMENTATION .....	69
4. SHORTER PROCESSING TIMELINE .....	72
5. BARRIERS TO IMPLEMENTATION .....	74

**Abstract**

This research addresses the impact of various practices in supply chain management with EDI and barcoding information technology. While EDI represents the state of art in business forms exchange, bar code represents the state-of-the-art in data collection. Together, these two business solutions, targeted at purchasing, receiving and shipping systems, allow everyone to operate more efficiently and profitably, while reacting more quickly and providing the best customer service available. A case study which examines the effects of EDI and Electronic Order System (EOS) technology at Kang Kuo Company in Republic of China (ROC) is presented.

This case study of the Kang Kuo Company provides insights into the use of information technologies through the supply chain in a Taiwan company. By implementing EDI, Barcoding, POS, EOS systems, the Kang Kuo Company has embraced the supply chain management and Quick Response strategies to boost their competitiveness, productivity, and profitability.

# SUPPLY CHAIN MANAGEMENT: A CASE STUDY OF USING EDI & BAR CODE INFORMATION TECHNOLOGY

## I. Introduction

Electronic Data Interchange (EDI) and barcoding provide information linkages between selling firms and buying firms and offer significant benefits for participating companies (Hill, 1994 ). This research addresses the impact of various practices in supply chain management with EDI and barcoding information technology. While EDI represent the state of art in business forms exchange, bar code represents the state-of-the-art in data collection. Together, these two business solutions, targeted at purchasing, receiving and shipping systems, allow everyone to operate more efficiently and profitably, while reacting more quickly and providing the best customer service available. A case study, which examines the effects of EDI and Electronic Order System (EOS) technology at Kang Kuo Company in Republic of China (ROC) is presented.

### General Issue

In the hopes of reducing costs by slashing inventory and improving efficiency across the supply chain, manufacturers and retailers have enthusiastically embraced the concept of supply chain management (Onge, 1996). Supply chain is defined as the flow of information and material to and from suppliers and customers. It is a series of activities/processes which plan, source, produce, and deliver products or services to customers (Franciose, 1995). Supply chain management means getting the right products to the right place with a minimum of cost, confusion and time (Gagliardi, 1996).

In the retail industry, retailers have viewed the supply chain as a horizontal set of interlocking activities that move merchandise from its point of origin to its point of sale (Hutchinson, 1995). All participants in the supply chain need to work as a team. In addition, the value of information technology throughout the whole supply chain is going to be critical in any company's ability to manage things in an integrated way. Common information technologies which have greatly improved supply chain efficiencies include bar codes, electronic data interchange (EDI), and continuing improvements in computer processing ability. The quick and efficient transfer of supply chain data is facilitated by information technologies; a more market-responsive supply chain is vital to success.

The retailer corporations have nearly exhausted all traditional approaches that can be done to optimize operations within the four walls of their enterprises. However, the traditional approach manages the supply chain by providing higher service levels through excess inventory and capacity. In other words, the traditional approach incurs an undue burden of cost (Stevens, 1989). Now the managers must look across the supply chain for the next step in improving the effectiveness of their logistics operations. Their objective is simple: to boost competitiveness and profitability (Copacino, 1996). Adding fuel to the movement are advances in information technology that make it possible to share information within and between companies on a more real-time basis (Crom, 1996).

### Background

Information is widely recognized as one of the most important enablers for supply chain management. Benefits of supply chain information are gained from coordination, the basis of which is information sharing. Even within a well-organized supply chain,

disruptions and inefficiencies can result from inadequate information sharing. Information technologies play significant roles in coordinating the supply chain (Fabris, 1996).

Leading companies are moving rapidly ahead in adopting concepts supporting supply chain management. They have refined earlier methods and have learned from mistakes made implementing best practices. However, they still need to acquire transportation skills and apply them in the context of supply chain management (Marien, 1996). And, probably most significant, many of these organizations are not waiting for the market to drive them to change- spurred either by customer demand or competitive disadvantage.

Best Practices. The supply chain is a horizontal set of interlocking activities that move merchandise from its point of origin to its point of sale. The best practices are based on a supply chain that can prepare stores to receive and shelve merchandise quickly, distribute it economically, ship it expeditiously, plan its purchases accurately and procure it profitably.

Efficient Consumer Response (ECR). Seldom has the search for supply chain's best practices taken on such industry-wide significance and prompted so much discussion as it has in the grocery business. One strategy that has taken hold is Efficient Customer Response (ECR). Theoretically, ECR is expected to reduce total costs by about 10%, by reforming the retailing industry's buying habits and moving toward continuous product replenishment (CPR) to get inventory into the store faster (Kalakota & Whinston,

1996). The average time to replenish grocery product inventory is more than 100 days.

In contrast, customers can get a car custom built and delivered in 42 days

(Kalakota & Whinston, 1996).

A continued emphasis on innovation through process and technology change is a common characteristic of the retailers viewed as ECR leaders. These leaders are focusing on comprehensive strategies for EDI and bar coding.

EDI and barcoding have taken on renewed importance as retailers and their partners look for tools to facilitate the rapid flow of information between their organizations. Two major changes in strategy from earlier EDI initiatives have taken place. First, retailers like Giant and Super Valu are using these technologies as “backbones” around which key business processes (such as ordering and receiving) are being built. Secondly, the scope of EDI transactions has broadened considerably, thus increasing the potential impact on the business and economic return (Margolies, 1995). ECR focuses first on reengineering business processes to make them efficient, then automating them, at much lower cost, to further reduce wasted time and cost.

Continuous Replenishment. Pioneers like Procter & Gamble and Wal-Mart built the ECR trail with experiments such as continuous replenishment, whereby information on stock sold one day at the retail level is transmitted electronically to the manufacture who replenishes the retailer’s inventory in a day or two. Continuous replenishment simply takes advantage of real-time sales data available through robust information systems. The real challenge comes in taking the next step of either direct store delivery or cross docking (which is a process that prevents products from coming to

rest as static inventory at the retailer's distribution center ). To achieve the full benefit, advanced sorting (which is a picking process that can increase the distribution efficiency and cut the leading time), EDI, and automated case handling techniques will be necessary (Martin &, Onge 1996).

Vendor Managed Inventory (VMI). In a VMI relationship, vendors receive withdrawal and current balance information from the retailer and replenish to a pre-determined inventory level. The vendors can arrange shipments, build their loads, and cut their purchase orders to optimize their transportation and inventory requirements. This is similar to Continuous Replenishment Planning (CRP), except the vendor is in charge of what and when to ship (Andel, 1996).

Generally, the ownership of the inventory is transferred to the retailer on receipt of goods. But a new facet is developing in VMI relationships: consignment. However, the supplier should provide logistics services to the manufacturer and customer as effectively or efficiently as a third-party logistics company. Third party logistics is commonly referred to as contract logistics, logistics partnerships, or integrated logistics, which provides all or a portion of a shipper's logistics activities. Third-party logistics adds to the bottom line of a retailer, as perhaps expected, but also adds to the bottom line of the manufacturer (Jenkins, 1996).

And in VMI relationships, information ownership is just as important as asset ownership. Electronic transfer of information between manufacturer and distributor is the most critical part of the process. Unless all partners in the supply chain share equal ownership of the information, someone will be left holding too much inventory. Whether a company ends up doing business on the Web, via EDI, or using some variation to these

themes, 21st century logistics will require using information to reduce inventory up and down the supply chain (Andel, 1996 ).

These best practices presented are based on experiences and lessons learned in already performed studies. For specific problems the supply chain is facing , best practices can contribute to finding solutions by studying others who have already solved similar problems (Anderson & Petterson, 1996).

The best practices of information technology adoption are growing rapidly and globally. While numerous studies have examined information technology adoption among U.S. companies, few have focused on other countries' companies. The results of a study which examined how information technology can best be implemented and adopted to other country's supply chain process will gain and maintain competitive advantage.

#### Purpose of Research

The purpose of this research is to gain insights into the use of information technologies through the supply chain of a Taiwan company. The Kang Kuo Company was selected for this case study because the company is a leader in implementing EDI and other forms of electronic communications for strategic benefit. By examining the information technology practices by a state-of-the-art practitioner, valuable lessons can be learned which may help facilitate future information technology adoptions by other countries' supply chains. Given the exploratory nature of this study, it may also be used as a basis for future empirical supply chain information research.

#### Research Objectives

There are four goals of this research:

1) To understand information technology standards and requirements across the supply chain.

2) Examine how information technology can automate manual activities, as when point-of sale scanning, rather than manual stock counting, is used for measuring sales.

3) Examine needed information technologies to integrate sales and operations planning as the basis for a more-responsive supply chain. Both functions require sharing real-time demand information within the enterprise and across the supply chain. At the integrated supply chain, the system ties customer and supplier together along with the flow of information in the supply chain. The aim is to reduce order cycle times. The shorter the cycle time, the faster a company can respond to changing market conditions.

4) To facilitate the adoption or implementation of best practices of ordering information technology.

These goals are meant to assist the supply chain decision makers in adopting the appropriate information technologies and applying the best practices for implementation.

### Research Questions

The following specific research questions were developed to facilitate the adoption of the information technology for the supply chain:

1. What information technologies are available to support supply chain management?

a) Is barcoding and "Point of Sale" data capture key in purchasing automation?

b) What information technologies can be extensively used to enhance the manipulation of information flow in buying and selling processes?

2. How has the Kong Kuo Company (in ROC) used these technologies to efficiently implement supply chain management?

- a) What motivated the Kong Kuo Company to begin the implementation of information system?
- b) What are the benefits of adopting electronic ordering to the Kang Kuo Company?
- c) What are the barriers preventing electronic ordering implementation?
- d) What successful strategies are used to overcome barriers?

### Methodology

Since the central purpose of this research was to study the best practices of information technology in the supply chain management, a qualitative research methodology was adopted. A detailed case study was conducted on the Electric Order System (EOS) within a wholesaler company, Kang Kou Company, which is one of Taiwan's largest, most successful distributors of dry good groceries for retail stores, supermarkets, and retail food chains in ROC. It has become the industry leader in adopting information technology for gaining a competitive edge and reducing overhead costs (MOEA, 1996). The study included three phases. The first phase consisted of a cursory review of literature on supply chain management and the related information technologies. The purpose of this phase was to provide the researcher with a working knowledge of the supply chain management, to limit the research effort, and to obtain additional data sources.

The second phase involved exploratory telephone interviews with the program manager at the Kang Kuo Company. In addition, another source of information for the

case study was company data. Documents pertaining to product policy, supplier meetings, and market feedback were reviewed.

The third phase constituted the primary data collection aspect of the research effort. This phase consisted of interviews with the Industry Institute of Computer & Communications, the Bar Code Facilitating Association, and the Information Industry Facilitating Association in Taiwan. Interviews covered general questions concerning the Electronic Ordering System (EOS), bar code standard, and EDI network. The purpose of this phase was to supply the researcher with the necessary expertise to facilitate analysis of the data collected.

Interviews were primarily conducted by telephone, due to interviewee availability and time constraints. Interviews were conducted with the following individuals:

1. Hsien-Cheng Chang      Program manager of Kang Kuo Company, Taipei, Taiwan, Republic of China.
2. Cheng-Ming Lee        System analyst of the Industrial Technology Research Institute, Computer & Communication Laboratories, Chung-Li, Taiwan, Republic of China.
3. Pei-Te Chu             National Taiwan Institute of Information Industry Taipei, Taiwan, Republic of China.
4. Hock-Hai Tan          Article Numbering Center of ROC Taipei, Taiwan, Republic of China.
5. Su-Lan Chen            Vanland Inc., Taipei, Taiwan, Republic of China.

Interviews were primarily unstructured and designed to derive further insight into the EDI, Barcoding, POS, EOS, VAN best practices and its resulting impact on

organizational processes within the Kang Kuo Company. The outcome of this effort was to answer the research questions outlined earlier in this chapter.

### Scope and Limitations

Although there are many organizations involved in the supply chain, the research was limited to a specific “wholesaler” organization- Kang Kuo Company, which has been successfully implementing EDI & EOS information technologies in Taiwan. There are several significant limitations to this study. First, the sample company is neither random nor proportionally representative of the supply chain organizations. Second, the perspectives of the Kang Kuo Company interviewed are limited to their knowledge of and experience with electronic ordering in the retail and manufacturing markets. While they may provide insights into the supply chain organizations, these perspectives may not be generalized to other organizations. Also, while much of what Kang Kuo has done may apply to many sales organizations, they should examine the specific costs and benefits of Barcoding and EDI in their businesses. Finally, the interviews reflect only the perceptions of the wholesaler which may be distorted or biased by individual or organizational characteristics.

### Chapter Summary and Organization of Research

This thesis consists of five chapters. Chapter one presented the general issues surrounding the research of the best practices and adoption of information technology within the supply chain. This chapter also described relevant background information, the purpose of the research, research objectives, research questions, methodology, scope and limitations of the research, and expected results.

Chapter two describes the information technologies within the supply chain and goes into detail on the EDI standard, Bar Code System, and EOS functions. Some of the most important concepts in EOS have been discussed such as POS and VAN.

Chapter three presents the case study of Kong- Kuo Sale Company's supply chain's Electronic Ordering System (EOS) implementation, using the information obtained from the previous chapter.

Chapter four presents the results and analysis of the data collected. The research results will yield evidence that the adoption of EOS information technology does increase the retailers competitiveness and profitability across the entire supply chain. Other information technologies such as the POS and Barcoding are also examined.

Finally, chapter five provides conclusions and recommendations derived from the research. Further research examining different types of technology is warranted. This is particularly important considering that an "information gap" has been identified relative to the delayed adoption of information technology in logistics.

## II. Supply-Chain Management: Information Technology

Supply-chain management requires the various parties in the supplier, manufacturer, and distributor chain to co-operate in the development of schedules and in the sharing of information. The rapid growth of Just-In-Time (JIT) facilitated by the revolution in electronic data interchange (EDI) has made organizations aware of the great benefits to be obtained by this wider extension of the logistics concept (Martin, 1992). With increasing global competition, many distribution companies are beginning to realize that they and their trading partners are indivisible parts of the supply chain. The use of

information technology to form a consolidated supply-chain has become an inevitable trend. Five major information technologies used are EDI, EOS, VAN, barcoding, and POS. This chapter is divided into four sections. The first section presents an overview of the supply chain management, and the remaining sections will provide a basic framework of information technologies used by supply chain management.

### Section 1 - Supply Chain Management (SCM)

Supply chain is defined as the flow of information and material to and from suppliers and customers. It is a series of activities/processes which plan, source, produce, and deliver products or services to customers (Franciose, 1995). Supply chains vary in length depending on the particular product or service focus, ranging from one contained entirely within a single company to an international multi-company supply chain. The major flows through supply chains are material, information, and cash.

While logistics management is concerned with the planning, implementation and control of the movement of physical objects and associated information in general, supply chain management focuses on the ultimate customer who creates the demand, which in turn supports the existence of the supply chain to provide the customer with the product (Ellram & Cooper, 1990). Supply chain management has been defined more broadly as an integrative philosophy to manage the total flow of a distribution channel from supplier to the end-user ( Jones and Riley, 1987). In short, supply chain management means getting the right products to the right place with a minimum of cost, confusion and time.

The objectives of SCM are:

1. maximize supply chain responsiveness and flexibility to customers.

2. minimize total supply chain cycle time, costs, and inventory, and
3. maximize supply chain capacity, utilization, and return on assets (Crom, 1996).

Suppliers, customers, and third party providers share the information and plans necessary to make the channel more efficient and competitive. Successful supply-chain management is extremely complex; the number of players involved means that each company's supply-chain management process will be unique. However, EDI and barcoding are information technologies that every company should implement when managing across the supply chain.

Supply chain management information helps expand one's customer base in two ways: First, one can identify the most profitable customers and products so that the organization knows where to expand. Second, one can open new channels for the distribution of products. Networking ties together information systems which have traditionally been separated. This tight integration provides timely, accurate and complete information to help understand one's business (Gagliardi, 1996).

Supply Chain Integration. The great benefit of supply-chain management occurs when all of the channel members- including suppliers, manufacturers, distributors, third parties , and customers act together to enhance performance significantly across the board (Copacino, 1996). Supply chain integration is an action where the entire supply chain, from suppliers through to the ultimate customers/consumers, is integrated and coordinated in order to achieve the “best” outcome for both the whole system and the ultimate customer, focusing on improvements to the flow of material, information, and cash throughout the chain (Franciose, 1995).

The Impact of Uncertainties. There are many sources of uncertainties in a supply chain: supplier lead time and delivery performance, quality of incoming materials, manufacturing process time (including machine downtimes, process yields, and reworks), transit times, and demand (Lee & Billington, 1992). A company can make great strides by understanding the relative impact of different sources of uncertainty in the system and by then working to reduce the impact they have (Davis, 1993). To reduce the impact of these uncertainties, supply chain managers must first understand their sources and the magnitude of their impact. The emphasis on Just-In-Time (JIT) strategy and information technology can lead to improved supplier delivery performance.

The Role of Partnerships. A strategic partnership is defined as a type of channel relationship where the intent of the relationship is to yield differentiated and intermediate or long term benefits to the parties involved in the relationship. This relationship is forward looking, takes place over an extended time period, and involves trust and the associated sharing of information, risks and rewards. Thus, an effective supply chain

management system is made up of a series of partnerships among firms, working together and mutually sharing information and channel risks and rewards (Ellram & Cooper, 1990).

Supply Chain Management Approach. The key challenge for business is to evaluate whether involvement in a strategic partnership and the associated supply chain management system makes sense. Supply chain management systems are complex, interrelated networks made up of multiple relationships at multiple levels throughout the channel from supplier to the ultimate user (Ellram & Cooper, 1990). A good supply chain management approach allows the firm to better meet customer needs. The supply chain is usually managed by the firm or individual with the most complete channel-wide inventory information. Thus, information technology and availability appears to be a key factor in determining the governance of a supply chain management system.

Information Technology. Information technology advances have profoundly changed business practices and continue to transform the nature of processing companies, industries and competition itself. Today's customers want reliable, efficient, top-quality service and information provided to them on a real-time basis. These expectations have been prompted by the ability of information technologies to deliver information quickly and accurately.

EDI and its second cousin, automatic identification, can be integrated to create extremely customer-responsive information, the Quick Response (QR), which is much like Just-In-Time (JIT) manufacturing. The goal of QR is to create a partnership between seller and supplier so that the right product reaches the right place at the right time at the right price. Quick Response is a strategy for shortening the pipeline from supplier of raw

materials to purchaser of finished goods at the checkout counter. The basic tools for implementing Quick Response are bar code scanning and electronic data interchange (EDI). However, the primary focus of Quick Response has been on the integration of the supplier to retailer, bar coding the product according to the retailer's specifications based on the UPC (Universal Product Code) and sending purchase orders and advance shipping notices by EDI.

A new strategy called Efficient Channel Integration (ECI) focuses on productivity gains and cost reduction through the application of bar coding and EDI to the movement of industrial hard goods, such as components and maintenance supplies. Like Quick Response in retail, Efficient Channel Integration is a necessity for manufacturers and wholesalers/ distributors of industrial hard goods to stay in business (Bernie, 1995).

## Section 2 - Electronic Data Interchange (EDI)

EDI is the electronic exchange of common documents such as purchase orders, invoices, and fund transfers (Wall, 1996). The definition preferred in this study is:

EDI is the paperless transmission of business documents between trading partner application systems, via a computer and communications network, in a standard message format. (Mackay & Rosier, 1996)

EDI makes a contribution to increased sales, reduced markdowns, and reduced inventory carrying costs by helping to speed the flow of information and merchandising through the retail pipeline. Therefore, the use of EDI is fast becoming a common element of logistics strategy. The major benefits of EDI are derived through reductions in clerical and administrative costs associated with the key entry, correction, and tracking of huge

volumes of business documents. Research has found that average annual retail sales increased by 0.14% from using EDI (CSAE, 1991).

History of EDI. Organizations traditionally have conducted business on paper, often using preprinted business forms to exchange information with trading partners. With the explosive growth of these paper-based exchanges, and the amount of data associated with the manufacture and sale of new products and services, many organizations have been forced to seek a more expedient way to communicate and process business data.

In the 1960s, some industry groups began a cooperative effort to develop industry EDI standards for purchasing, transportation, and financial applications. Many of these standards supported only intra-industry trading, but others, such as bills of lading and freight invoices, were applicable across industries. Eventually the idea of national standards for use across industries received substantial support.

In the late 1970s, using the pioneering work of the Transportation Data Coordinating Committee and the National Association of Credit Management's Credit Research Foundation, Accredited Standards Committee X.12 (or ASC X.12) began the development of its first standards for electronic data interchange. In 1983 ANSI published the first five American National Standards for EDI. In 1989, Version 2, Release 4 was published and contained 32 standards. In 1993, Version 3, Release 4 contained 192 Draft Standards for Trial Use (DSTUs), including most of the transportation and retail industries' standards. With publication of Version 3, Release 6 in 1995, the standard included 245 DSTUs with additional standards and guidelines now in development (DISA, 1996).

Currently standards are in development to support needs of the US government, advertising, insurance, education, entertainment, and mortgage banking industries. As other industries and businesses join ASC X.12's development activities, additional types of transactions are included in the body of the standards.

EDI Standards. Electronic Data Interchange (EDI) is the exchange of routine business transactions in a computer-processable format, covering such traditional applications as inquiries, planning, purchasing, acknowledgments, pricing, order status, scheduling, test results, shipping and receiving, invoices, payments, and financial reporting. In 1979, the American National Standards Institute (ANSI) created the ASC X.12 to develop and maintain US EDI standards. With an increasing number of global trading partners, many companies realize that they need international EDI standards. In 1985, the United Nations established the Electronic Data Interchange for Administration, Commerce, and Transport (UN/EDI-FACT) for international standards. The groups have developed hundreds of standards allowing companies to share data, regardless of the computers, networks, and vendors they're using (Wall, 1996). Additional standards cover interchange of data relating to security, administrative data, trading partner information, specifications, contracts, production data, and distribution and sales activities.

EDI formats not only differ internationally, but also differ from industry to industry and among firms in the same industry. A variety of industry-specific standards have been developed. Some popular examples are: UCS (uniform communication standard) for the retailing industry; WINS (warehouse information network standard) for the warehousing industry; TDCC (transportation data co-ordination committee) for the transportation

industry, CIDX (chemical industry data exchange) for the electronics industry (Chiu, 1995).

Structure of EDI Transactions. EDI standards are very broad and general because they have to meet the needs of all businesses. EDI messages, however, share a common structure:

1. Transaction set is equivalent to a business document, such as a purchase order. Each transaction set is made up of data segments.
2. Data segments are logical groups of data elements that together convey information, such as invoice terms, shipping information, or purchase order line.
3. Data elements are individual fields, such as purchase order number, quantity on order, unit price.

The concept and theory of EDI has evolved from the transmission of data in "fixed-length" proprietary formats to the transmission of data in "variable length" standard formats. Without these standard formats, industry utilization of computer-to-computer communication technology would be encumbered by the use of different formats and data contents.

EDIFACT and ASC X.12 Standards. Most US companies subscribe to the ASC X.12 standard, while most companies in Europe and Asia subscribe to UN/EDIFACT (Chiu, 1995). Although EDIFACT is similar to ASC X.12 in both purpose and approach, sufficient technical differences exist that may inhibit interoperability. As global trade expands, most US companies will require implementation of both standards. Fortunately, an awareness of commerce's international nature and the desirability of a single EDI

standard have resulted in a decision by the ASC X.12 committee to align its standard with EDIFACT by 1997 (Kalakota & Whinston, 1996).

The X.12 transaction sets generally map a traditional paper document to an electronic format that can move easily over telecommunication networks. Each transaction format includes many data segments needed for the business function as well as instructive information to ensure that the telecommunication system routes the data correctly. Table 1 shows examples of ANSI ASC X.12 transactions.

Table 1. Examples of ANSI ASC X.12 Transactions

Transactions	Form number
Vendor Registration	838
Request for Quotation	840
Response to Request for Quotation	843
Purchase Order or Delivery Order	850
Purchase Order Acknowledgment	855
Functional Acknowledgment	997

These X.12 transactions are transmitted to the trading partner (TP) through either the X400 e-mail protocol, or the multi-purpose Internet mail extensions(MIME) protocols. EDIFACT is a family of standards similar to ANSI X.12.EDIFACT was based on TRADECOMS, developed by the U.K. Department of Customs and Excise. EDIFACT

is becoming widely accepted as the foremost international EDI standard. Therefore, EDIFACT and ANSI are working towards compatibility.

How EDI Works. The ASC X.12 standards specify the format and data content of electronic business transactions. For an example, see Figure 1 , where a traditional paper invoice is “mapped” to an ASC X.12 invoice standard. Definitions of the terms used are provided in the next paragraph, Figure 1 shows how business information is formatted, according to the standard, prior to transmission to a trading partner. Figure 2 shows the same data on a traditional paper invoice (DISA, 1996).

The following foundation standards shown in the Figure 1 (in column “NOTES”) are required to interpret, understand, and use the ASC X.12 series of transaction set standards, which in turn define the format and data contents of business transactions. The “foundation standards” define the syntax of ASC X.12 EDI, as well as the data elements, data segments, and control structures.

X12.5 Interchange Control Structures. X12.5 contains specifications for the control structures (“envelope”) for the electronic interchange of one or more transaction sets. This standard provides the interchange envelope of a header segment (ISA) and trailer segment (IEA) for the interchange through a data transmission and provides a structure (TA1)to acknowledge the receipt and processing of this envelope.

NOTES	ASC X.12 FORMAT	SAMPLE INVOICE CONTENT
Interchange Control Header, ISA Segment, see X12.5	ISA* 00*0000000000* 01*01*PASSWORDME* 01*123456789bbbb*987654321bbbb*8907 14*2210*U*00204*000000008*0*P*N/L	<b>Outside Envelope</b>
Functional GroupHeader, GS Segment, see X12.22	GS*IN* 012345678* 087654321*900509*2210* 000001*X*00204N/L	<b>Inside Envelope</b>
Transaction Set Header, ST Segment,	ST*810*0001N/L	<b>Invoice</b>

see X12.22						
	BIG*970313*1001*970225*P989320N/L	DATE ORDER DATE INVOICE # CUSTOMER ORDER# P989320	3/13/97 2/25/97 1001			
	N1*BT* ACME DISTRIBUTION COMPANY N/L N3*P.O.BOX 33327 N/L N4*ANYTOWN*NJ*44509 N/L	CHARGE TO	Acme Dist. Company P.O. Box33327 Anytown, NJ44509			
	N1*ST*THE CORNER STORE N/L N3*601 FIRST STREET N/L N4*CROSSROADS*MI*48106 N/L	SHIP TO	The Corner Store 601 first Street Crossroads, MI 48106			
	N1*SE*SMITH CORPORATION N/L N3*900 EASY STREET N/L N4*BIG CITY* NJ* 15455 N/L	REMIT TO	Smith Corp. 900 Easy Street Big City, NJ 15455			
	PER*AD*C.D.JONES*TE*6185558230 N/L	CORRESPONDENCE Dept TO	Accounting  C.P. Jones (618)555-8230			
	ITD*01*3*2**10 N/L	TERMS OF SALE from	2% 10 days invoice date			
		QUAN	UNIT	SUPPLIER BRADE CODE	DES- CRIPTION	UNIT PRICE
	ITD*01*3*CA*12.75**VC*6900*	3	Cse	6900	Cellulose Sponges	12.75
	IT1**12*EA*.475**VC*P450 N/L	12	Ea	P450	Plastic Ball	0.475
	IT1**4*EA*.94**VC*1640Y N/L	4	Ea	1640Y	Dish Drainer	0.94
	IT1**1*DZ*3.4**VC*1507 N/L	1	Dz	1507	6"Plastic Flower Pots	3.40
	TDS*5111 N/L	Invoice Total				
	CAD*M****CONSOLIDATED TRUCK N/L	Via Consolidated Truck				
Hash Totals	CTT*4*20 N/L	(4 line Items, Hash Total 20)				
Transaction Set Trailer	SE*21*000001 N/L					
Function Group Trailer	GE*1*000001 N/L					
Interchange Control trailer	IEA*1*000000008 N/L					

b= Space Character \*=Data Element Separator N/L= Segment Terminator

Figure 1. A Description of the ASC X.12 format for a typical invoice (Source from DISA).

 <b>Smith Corporation</b>  900 Easy Street Big City, NJ 15155 (618) 555-6765	<b>Invoice No. 1001</b>
---	-------------------------

CHARGE TO		INVOICE	3/13/97	SALES	NTO
		DATE		PERSON	
Acme Distributing Co. P.O. Box 33327 Anytown, NJ44509		SHIP TO	The Corner Store 601 First Street Crossroads, MI 48106		
YOUR ORDER NO.		CUST REF NO.	ORDER DATE	TERMS	
P989320		66043	2/25/97	2% 10 days	
QUAN.	UNIT	NO.	DESCRIPTION	UNIT PRICE	TOTAL PRICE
3	Cse	6900	Cellulose Sponges	12.75	38.25
12	Ea	P450	Plastic Pails	0.475	5.70
4	Ea	1640Y	Yellow Dish Drainer	0.94	3.76
1	Dz	1507	6" Plastic Flower Pots	3.40	3.40
Please direct correspondence to:					
C.P. Jones					
(618) 555-8230					
PLEASE PAY THIS AMOUNT					\$51.11
DATE SHIPPED	3/13/97	SHIPPED VIA	Consolidated Truck		
<b>ORIGINAL</b>					

Figure 2. The Same Data on a Traditional Paper Invoice

X12.22 Segment Directory. X 12.22 segment directory and X12.3 data element dictionary define the segments and data elements, respectively, that are used to construct the transaction sets. They must be used at the same version/release level as transaction sets. They are not available as separate publications.

EDI in Action. EDI can substantially automate the information flow and facilitate management of the business process, as illustrated in Figure 3. The EDI transactions for a purchase, shipment, and corresponding payment are as follows (Kalakota & Whinston, 1996):

- Step 1. Buyer's computer sends purchase order (PO) to seller's computer.
- Step 2. Seller's computer sends purchase order confirmation to buyer's computer.
- Step 3. Seller's computer sends booking request to transport company's computer.
- Step 4. Transport company's computer sends booking confirmation (BC) to seller's computer.
- Step 5. Seller's computer sends advance ship notice (ASN) to buyer's computer.
- Step 6. Transport company's computer sends status to seller's computer.
- Step 7. Buyer's computer sends receipt advice to seller's computer.
- Step 8. Seller's computer sends invoice to buyer's computer.
- Step 9. Buyer's computer sends payment to seller's computer.

The seller and buyer are adopting EDI as a fast, inexpensive, and safe method of sending invoices, purchase orders, customs documents, shipping notices, and other frequently used business documents. EDI translates these documents into a standard electronic format, and transmits it. At the receiving end, the standard format is "untranslated" into a format that can be read by the recipient's application. Hence output from one application becomes input to another through the computer - to - computer exchange of information (Kalakota & Whinston, 1996).

The Purchase Order Confirmation is the seller's acceptance of the price and terms of sale. Note that the various internal departments are aggregated and called buyer and

seller to simplify the description. All the interactions occur through EDI forms and in most cases are generated automatically by the computer (Kalakota & Whinston, 1996).

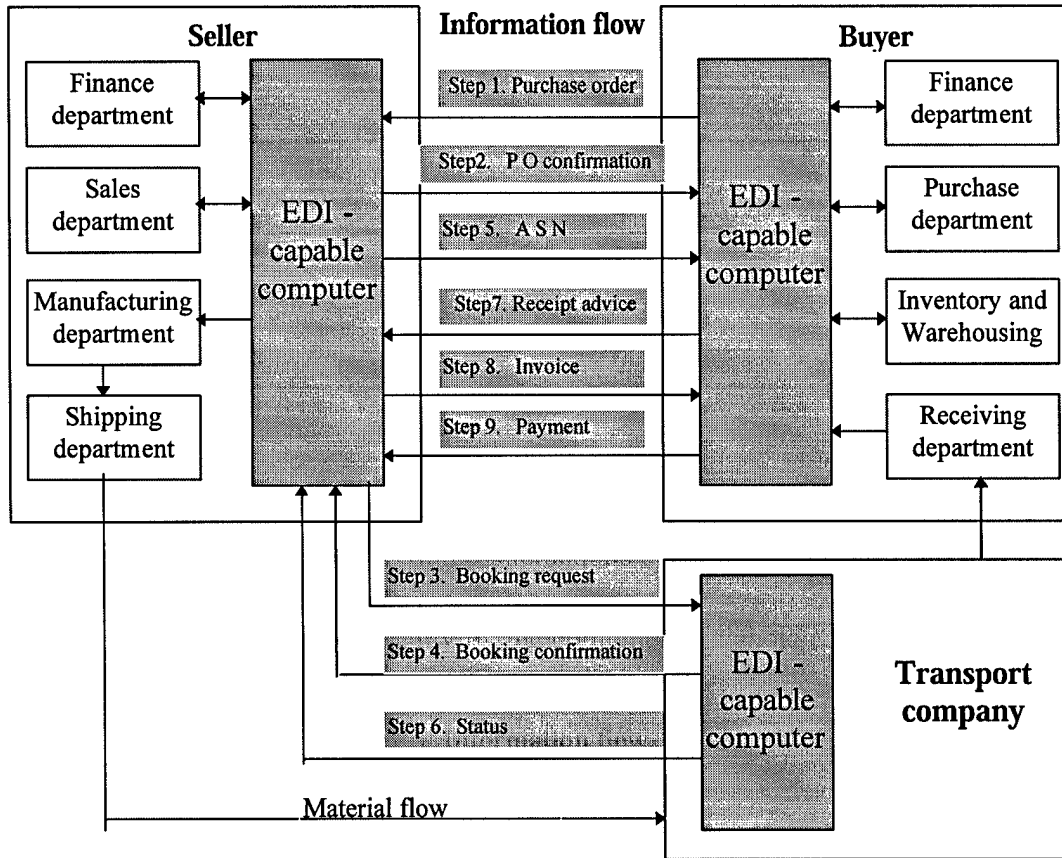

Figure 3. Information Flow With EDI (Adapted from Kalakota & Whinston, 1996)

The Functions of EDI in Different Organizations EDI is the transmission of structured data messages between computer applications. This method of moving information has already made great strides into the Automotive, Transport and Retail business sectors in the past few years and looks set to become the primary method of business data transfer in the next century. EDI helps various functional departments meet their quality objectives:

Customer Service. With the EDI system continuously updated throughout the day, customer service will have access to more timely information in order to respond to customer telephone inquiries. In fact, in a more sophisticated environment, the EDI system itself can respond to customer inquiries.

Manufacturing. Manufacturing can achieve a true Just-In-Time (JIT) environment with EDI. With a JIT strategy in place, a manufacturer will issue more frequent orders with fewer units instead of the traditional habit of ordering large quantities at one time. This process virtually eliminates safety stock and turns inventory more frequently, therefore dramatically reducing carrying costs (Biby, 1992).

Purchasing. The purchasing component of the EDI system can issue a purchase order automatically, based on present inventory thresholds. Order-entry errors are eliminated on the seller's end because EDI removes the need for rekeying order information. Further, an EDI system can automatically source a particular item from the supplier offering the best quality. Historical performance data will point to a select few preferred vendors and eliminate the rest.

Sale. Many EDI-capable manufacturers are converting their sales catalogs to electronic media sales representatives in the field -(customers)- who can retrieve this catalog for up-to the -second product updates and pricing, or to place orders. The result: fast order turnaround and more accurate order fulfilling.

Shipping. The point of shipment is the point of “no return.” It is the last opportunity the shipper has to ensure quality before the product gets to the customer. In an EDI/ Quick Response environment, the shipper creates an advance ship notice (ASN) from shipment data. The ASN is an electronic “snap shot” of the shipment and is transmitted to the consignee before the shipment leaves the dock.

To implement EDI, a retailer needs an EDI architecture, or infrastructure, which includes hardware, application and translation software, communications vehicles, and an organization to manage and control the whole process. To permit large-scale linkages among trading partners, third-party networks and mailboxes (which is used to handle electronic data, reduce cost, and enhance EDI in the 3rd-party VAN, (communications news, 1996) have become important parts of EDI architecture, Third-party providers have also established an interconnect facility whereby the service providers establish a linkage allowing electronic mail to come in on one network and to be switched over to the other network without additional effort on the part of the sending or the receiving company.

Evolution of EDI Standards. These were the working documents which formed the basis of the 1983 ANSI Version 1, EDI Standard. In an attempt to overcome some of the perceived disadvantages of industry-specific standards, ASC X.12 used the generic

business standards paradigm when it began standards development. These standards were built using the same components (transaction sets, segments, data elements and code lists) as the industry-specific standards, but were constructed in such a way that they could be used by any industry. Although it was understood that these industry-specific standards were not perfect, they allowed a quick, easy development path and provided interested parties a functional solution (DISA, 1996).

Suffice it to say that neither approach (industry-specific and generic) afforded the EDI implementor a clear-cut advantage. By examining what worked for both models and what didn't, The standard-setting organizations can develop some requirements for the next paradigm. The next generation of EDI standards, which we have called Universal EDI Standards, must be:

1. cost effective to allow global implementation, regardless of organization size or technical capabilities
2. free of all ambiguity
3. provide explicit support for the business context (WWW, 1997).

The Future State of EDI. EDI will use a new paradigm for information exchanged among trading partners. Electronic conversations will use information from corresponding enterprise models and "EDI-enabled" application systems. This paradigm will allow for a dialog-oriented style of communicating. For example, a buyer's order-generating application sends a purchase order to the supplier's inventory control system, which more flexible, rule-oriented buying applications will "converse" with more flexible, rule-oriented selling applications. These applications will inquire about available stock and delivery

times, receive a response, and submit an order. The future state of EDI will support robust contextual data to relate these messages and trigger actions and responses that are not necessarily predetermined (WWW, 1997).

### Section 3 - Bar Code System

Bar code, the most advanced automatic identification technology available applicable to individuals and objects, has been used successfully in most parts of the world for about 25 years. Its purpose is the repeated identification of items for industrial and commercial purposes. The great acceptance of the bar code system is due to its accuracy, precision and reliability in collecting printed data automatically and systematically and to its capacity for establishing unique communication and exchange links between mass-scale manufacturers and distributors of mass consumer products (Erdei, 1993). Figure 4 shows the complete bar code system.

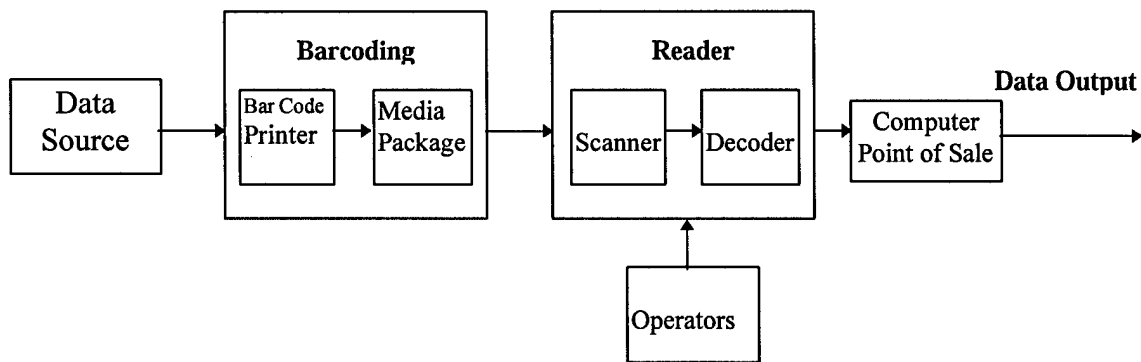

Figure 4. Bar Code System

A bar code system requires two components. First, the barcoding process, assigns a code to an item and prints it in the form of a bar code that can be attached to the item.

The second, a reader scans and reads the bar code and decodes it back into the identifying code in recording a computer transaction referring to the item (see Figure 3) (Socka, 1993).

Bar code consists of lines and spaces of varying width that contain data under different headings known as symbologies (Erdei, 1993). Bar codes are widely used to provide specific information about the objects to which they are attached. Bar coding offers benefits to manufacturing, warehousing, distribution centers, and retail industries. Bar codes are used to quickly provide accurate information from which business decisions can be made (Topel, 1990).

Reading bar codes requires a reader that is most often connected to a computer terminal or PC between the keyboard and the terminal or PC. In this way, data that is read from the bar code simply becomes input as if it were typed on the keyboard. More sophisticated systems use portable bar code readers that collect the information from a number of transactions, on a shop floor for instance, and then download them in a batch to the computer system for processing (Socka, 1993).

Bar code readers include pen type wands that must be rubbed right against the printed bar code to read it, as well as laser-powered reader "guns" that can read a bar code from two or three meters away. In retail, library, and filing room operations, the encoded items are often moved past a fixed bar code scanner.

Bar Code Standards. There are several different types of bar code standards: symbology standards, print quality standards, data content code standards, and labeling standards.

Symbology Standards. Symbology standards define how to encode characters (numbers, letters, punctuation marks, etc.) using bars and spaces of varying widths. Bar codes are like a visual version of Morse Code. Instead of using dots and dashes to represent characters, unique patterns are created using bars and spaces of varying widths. The rules describing how to encode data in patterns of bars and spaces are called "symbologies." Symbology standards are maintained by a several organizations including AIM USA (the Automatic Identification Manufacturers), UCC (the Uniform Code Council) and ANSI (the American National Standards Institute).

New information requirements, technical advances and reduced costs in on-demand printing technology, optics and decode technology have stimulated the development of new symbologies. As new symbologies are developed, older symbologies are not rendered obsolete. Decoders are updated to read the old and new symbologies. Printing software is updated to print both the old and new symbologies(Cardais, 1994).

Print Quality Standards. In 1990, ANSI published ANSI X3.182-1990 Bar Code Print Quality Guidelines. This standard defines a measurement procedure and a standardized method of evaluating (scoring) bar codes by using either a letter or numeric grade based on either a letter or numeric grade based on eight different attributes of the bar code symbol. In essence, the ANSI bar code print quality standard defines an unambiguous way of saying how close to “perfect” a bar code is (Cardais, 1994).

Most new labeling standards reference the ANSI X3.182 bar code print quality standard. Some existing standards are being revised to reference the ANSI standard. At its 1994 board meeting, the UCC board of governors approved the Quality Specification for the UPC Printed Symbol. This new specification updates the procedures defined in the UPC Symbol Specification Manual. The new UCC standard was based in part on the symbol quality measurements defined in the ANSI X3.182 standard (Cardais, 1994).

Data Content Code Standards. Data content codes are used to tell a data collection system what type of data is encoded in a bar code symbol. Consider a label containing four bar code symbols representing the following data: part number, purchase order (PO) number, batch number, and quantity (pieces). Using the ANSI MH10.9M FACT Data Application Identifiers for Materials Handling, the bar code containing the

part number would start with the letter “P” if the part number was assigned by the customer and “1P” if the part number was assigned by the supplier. The symbol encoding the customer’s PO number would start with the letter “K.” Batch number would start with the letter “T,” and quantity would start with the letter “Q.” Knowing this, the system would be able to map this data to the appropriate places in the data base automatically.

Over the years, two data content code standards have emerged: the ANSI MH10.9 FACT data identifiers referenced above and the UCC Application Identifiers (AIs). The two different standards do not conflict. To reduce the confusion that might be caused by the existence of two standards, ANSI and UCC committees harmonized their standards by publishing a cross reference table. The Table 2 shows a few examples of this (Cardais, 1994).

Labeling Standards. The labels applied to individual products and shipping containers are typically defined in a “bar code labeling standard.” Frequently, the label standards are developed for a specific industry to satisfy their unique information requirements. Examples include the automotive industry (AIAG standards), health care (HIBCC standards), plumbing industry (IBCA standards) and the electronics industry (EIA standards.) Sometimes, companies will develop a “company-specific” labeling standard (Cardais, 1994).

Table 2. ANSI / UCC Cross Reference Table

Data	UCC Standards	ANSI / FACT Standard
Batch number	10	T
Serial number	21	S

Customer's PO number	400	K
Ship/deliver to postal code	420	52L

UPC/EAN Code. Manufacturing industries request from the national association (Uniform Code Council) in charge of code assignment, a set of numbers that will identify the company and will be the same for all items from the same company; next, separate numbers can be assigned to each item or item variation, with which a unique series of numbers for each item, known as CODE, is defined including:

**COUNTRY + MANUFACTURER + ITEM + CONTROL**

A 12-digit code known as UPC, or Universal Product Code, in the USA and Canada, or a 13-digit code called "European Article Numbering" (EAN) elsewhere in the world, is thus formed. This code is composed of a number of vertical bars, or symbol, plus a set of printed numbers, or character set, in human readable characters. Outside the United States and Canada, all countries use the UPC bar code system, both for domestic and international needs (Erdei, 1993).

Distributors, such as supermarkets or retail stores, adopt the UPC/EAN code of each item for identification in their internal network made up of various departments such as purchasing, stock, management, accounting, traffic and sales, using a central computerized system in different sectors of the organization linked to their checkout counters or points of sale (POS).

Linear Versus 2-Dimensional Bar Codes. One of the central technology issues manufacturers and suppliers committed to bar-code data capture must grapple with is the

transition from traditional linear one-dimensional bar-code symbols, to high-capacity two-dimensional (2-D) bar codes (Bowen, 1995).

Two-dimensional bar-code symbols offer several advantages. They can hold a much larger amount of data than the familiar linear codes, such as UPC and EAN, used for product identification, and Code 128 and Interleaved 2-of-5, endorsed for shipping container identification (Robins, 1995). The 2-D bar codes also support error correction and omni-directional scanning, which increases the flexibility of automated data capture and processing systems.

Code One and PDF417 are examples of 2-D bar codes. The most common of which is PDF417, a stacked linear bar code. PDF417 codes can be read by some of the newer scanners that can also process traditional bar codes, such as linear CCD (charged coupled devices). A 1.5 by 1.5 in. PDF417 can hold more than a kilobyte of data (Robins, 1995).

Barcoding. Barcoding of products is the first step towards retail automation. Store automation led by Point Of Sale (POS) systems has become indispensable in the logistics management strategies of distribution firms. In some developing countries, the percentage of use of the Universal Product Code (UPC) is not high because most retail stores conventionally have used the company-specific in-store codes. This situation has been an impediment to the widespread use of POS systems.

Point of Sale (POS) System. The UPC data and price list are regularly provided by the mainframe in the corporate headquarters. In each store, a super-micro or minicomputer that monitors the POS terminals maintains the UPC database and price list.

Almost all sales information can be gathered by the front POS (FPOS) system in a more timely and accurate way. The rear POS (RPOS) system analyzes sales information from the FPOS system, prints out the UPC barcodes, manages goods by product and places electronic orders (Figure 5 Point of Sale (POS) system). In addition, the RPOS system handles merchandise receiving and inspection, inventory control, physical counting, accounting and vendor management. One benefit of POS systems is that the results from sales analysis can show which product is the best seller and which is the sticker (Chiu, 1995).

POS is an essential strategy for mere survival in increasingly cost-sensitive times. In addition, automating data capture with barcoding technology is an essential ingredient in Supply Chain Integration (SCI) solutions. The SCI is an action where the entire supply chain, from suppliers through to the ultimate customers/ consumers, is integrated and coordinated in order to achieve the “best” outcome for both the whole system and the ultimate customer, focusing on improvements to the flow of material, information and cash throughout the chain (Franciose, 1995). Therefore, POS is quickly rising to the level of competitive necessity in the SCI.

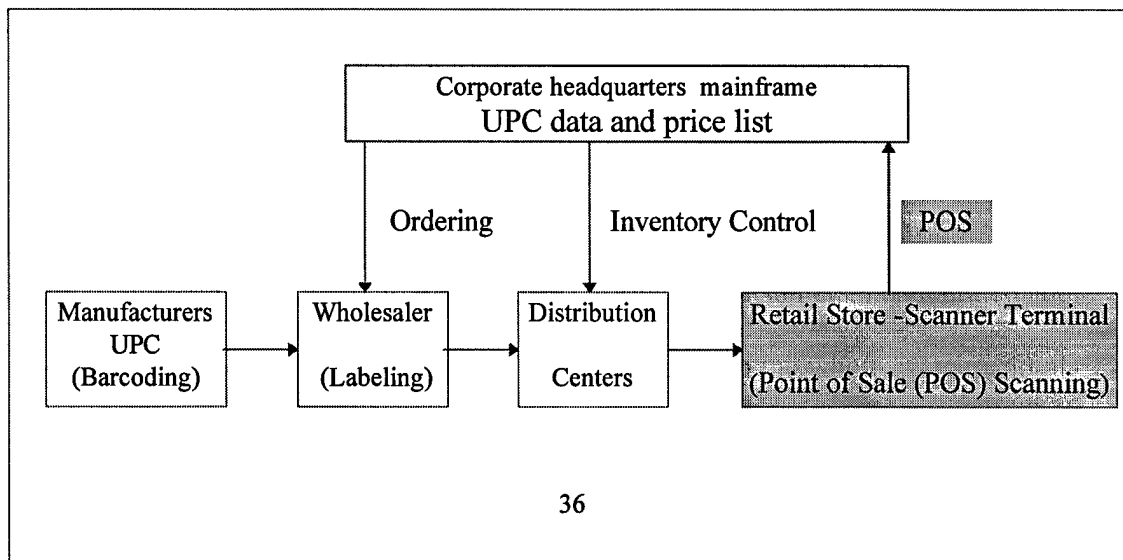

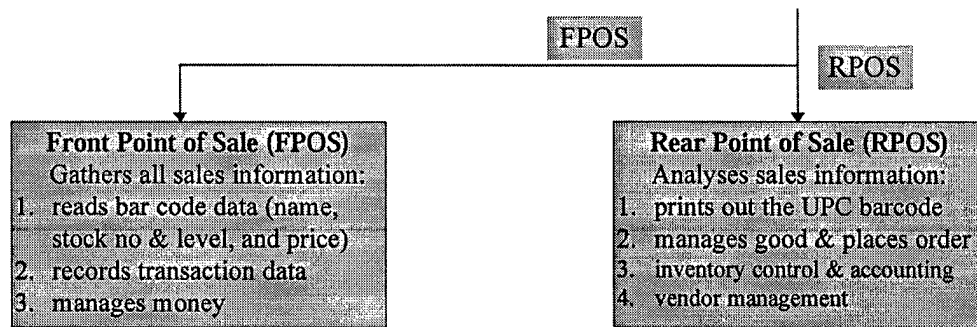

Figure 5. Point of Sale (POS) System

Industry experts believe automated data capture with bar-code readers (scanners) will be integrated into every major transaction point in the manufacturing, distribution, and supply chain. This process includes work-in-process manufacturing, the transition to finished goods warehousing, shipping and receiving at each distribution point, and of course, point of sales (POS). The reason is simple - fast, efficient, and accurate data capture. The ability to capture data in a near real-time operation is the key ingredient that allows supply chain integration (Bowen, 1995).

The Scanner at the Point of Sale. A scanner is used to distinguish the differences between the bars' width by the contrast between them. POS are equipped with a reading device known as a scanner on the countertop where a light beam, usually red laser, constantly scans in many directions at very high speed, exploring and analyzing data in three dimensions; this process is known as scanning.

The Data Capture of the Scanner. When an item is scanned, the scanner recognizes the presence of an object within its visual field and activates a security window effect for as long as the object remains in that zone, thus preventing checking of the same

item twice. The information is immediately collected and decoded by a computer until a specific interpretation is obtained, that is, the identification of a code number belonging to the bar code system for which it was programmed.

POS information is processed and stored in computers. Both memory and central logical decision-making can easily be handled by a standard electronic computer compatible with most popular brands and models available everywhere. They can be interconnected or linked to branch offices and distributors for data centralization.

Distributors can improve performance and decision-making, as they will immediately and accurately be able to handle all data from retail outlets, whether located at the headquarters or not. Distributors will be able to know the stock period of every item and the daily habits of consumers and their shopping routines. In this way, distributors can plan times for special sales, which items to include and at what price.

Distributors will also know the items and brands consumers prefer, so they can restock supplies according to better selectivity criteria and spot the best moment to sell low-turnover goods. If distributors share information with their suppliers, sales data, can also feed the production system by recommending changes after considering customer preferences for a given form of packaging, presentation, size, color, or taste.

The Scanners. The scanner can be used to collect data or perform symbol quality control. Scanners explore symbols by shedding light across them and collecting the reflected beam with an optical transducer, converting a visible or invisible electromagnetic wave into an analogical electric signal. A decoder transforms this signal into digital form and process it, checking it corresponds 100 percent to the programmed

bar code. The code is identified and transmitted to a central computer. In some cases the decoding circuit is located inside the scanner case (Erdei, 1993).

The different types of most commonly used scanners are described and divided into two groups, depending on whether it is a hand-held scanner or a fixed scanner, as shown in the Figure 6.

Handheld Scanner. The object remains unmoved while scanner or light motion, is manual or automatic.

Manual Motion. Scanner is manually moved (manual wand); low price and low consumption make it suitable for small jobs. This scanner provides one reading at a time (about 1 reading per second), requires minimum training to keep speed and constant operating angle and will not scan other than top-quality symbols, of any length.

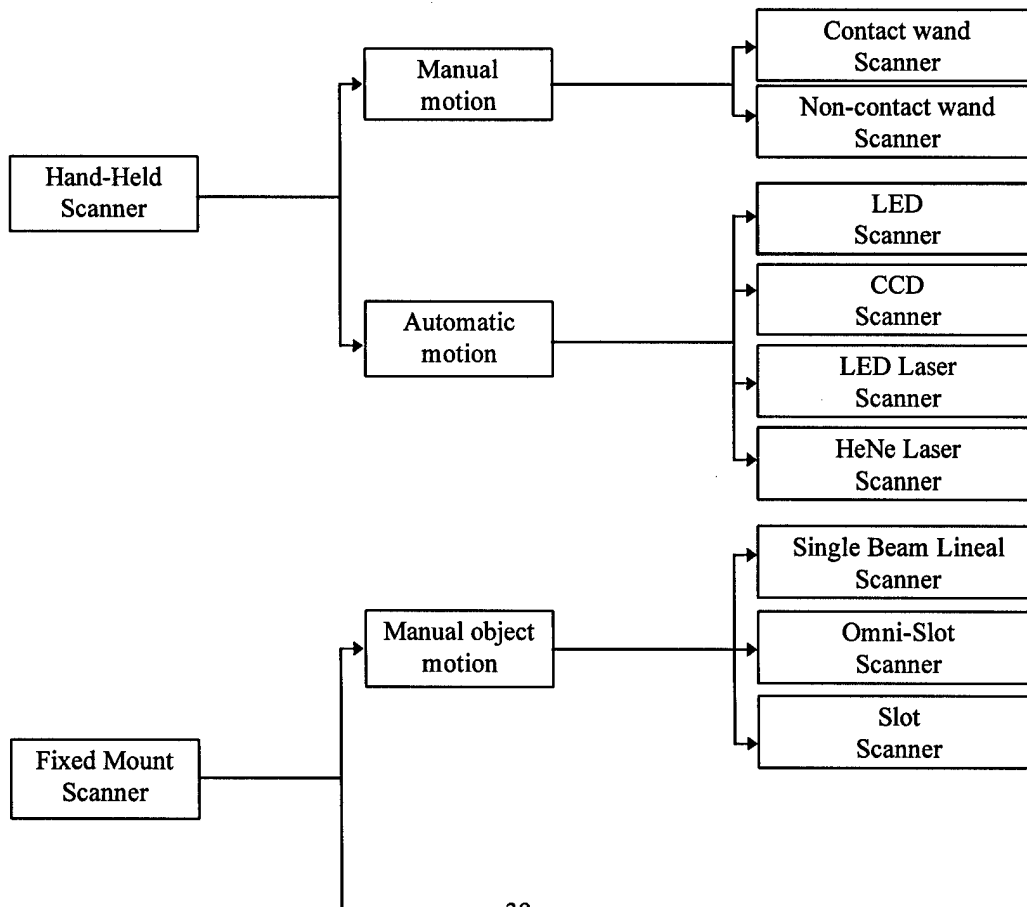

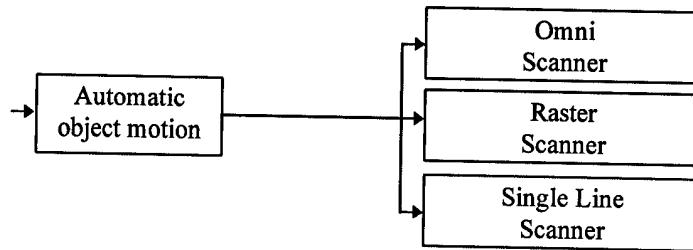

Figure 6. The Different Types of Scanners

Contact Wand Scanner. Equipped with LED transducers, this scanner usually pencil-shaped, containing one to four LEDs and a collecting photoelectric cell. Some of these are the cheapest and simplest scanner types. They can scan only two-dimension codes and must make direct contact with the code, using minimum energy consumption. Used in most handheld analyzers, because of direct contact with the code, focusing errors are minimum; scanning angle and direction are critical (Erdei, 1993).

Noncontact Wand Scanner. Code should be kept within a narrow field depth range, and three dimensions are controlled, so curved or irregular surfaces can be scanned. Small or truncated symbols are not properly scanned, and moving objects can be scanned in some cases. Also suitable for symbols in hard-to-reach locations.

Automatic Motion. The object remains still and the scanner light moves automatically, through mechanical or electronic means. Can perform multiple scans per second and recurrent reading. No special training required, can read medium-quality printings.

Noncoherent Light LED Scanner. Light spreads out in non-coherent form, in different directions rather than in-phase, and sometimes with different wavelengths, like some LEDs, incandescent bulbs, sunlight or candlelight. Energy is

dispersed, so field depth ranges are narrow. They have a limited field depth, usually lower than 15 cm, and a lower-than-10 cm scanning width. Depending on code density, this scanner may require adjustments, so it is recommended for scanning only one type of code.

CCD Scanner. CCD, or capacitor coupled discharge, are virtual contact devices capable of scanning through real contact or up to 2.5 cm distance, can scan codes on irregular or curved surfaces. Usually very light weight and small, with or without built-in decoder, features audio or visual scanning signal. Switch -or code-operated, this scanner offers different width fields, depending on code type. Gives good performance with no previous training and an average of 50 - 100 scans per second, according to brand, Sheds light on the code through a flat front red light, collects flat beam reflected on a microcell panel where capacity discharge cells transform light into an electronic signal to be decoded.

LED Laser Scanner. The laser light travels as a coherent beam, so all waves are equal in frequency and amplitude and are perfectly in phase. High-energy concentration occurs, and dispersion is so little that under theoretically suitable conditions the Moon could be illuminated from the Earth. For this reason, scanners can focus with maximum accuracy at different distances, enabling the obtaining of high field depth ranges on irregular or curved surfaces. Light beam moves through optical and mechanical means, so no previous training is required. LED Laser Scanner based on semiconductor solid state electronic devices known as light emitting-diodes (LED). Provides very good field depth (up to 45 cm) and field width (up to 28 cm). Light and small, it usually features built-in decoder. consumption is low: 0.5-0.75W.

Gas HeNe Laser Scanner. Transducer consists of a gas-filled tube where high molecular excitation occurs. This generates a coherent beam of electromagnetic waves, or laser. Light is usually red field depth and field width are usually higher than LED lasers. Size and consumption are obviously greater than LED laser.

Fixed Mount Scanner. This scanner remains still while the object advances manually or automatically.

Manual Object Motion. Items advance manually for this scanner, which is generally used for general applications.

Single Beam Lineal Scanner. Light beam scans visual field in a straight line, producing a visible red light that ensures accurate focusing. Models are usually compact, non bulky, and can be easily accommodated even on desktops. Field depth is high, about 60 cm and can operate on any code in every density.

Omni-slot Scanner. This is the most popular scanner used at point of sale such as supermarket checkout counters. A light beam scans the visual field in three or four straight lines at the same time (omni-slot), making symbol orientation unnecessary. Usually the scanner is horizontally placed on countertops next to checkout machines, and the window usually faces up. although it can be placed vertically. Glass window should be cleaned on a regular basis and replaced annually. Up to 15,000 items can be processed in an hour; traditional field depth is up to 25 cm, and average operation rate is 500 scans per second. Scanner life is estimated at 10 years of normal use.

Slot Scanner. Scanner is low-priced and provides lower-quality performance. Items should be scanner-oriented adequate scan.

Automatic Object Motion. Items advance automatically for this scanner, which is generally used for industrial applications.

Omni Scanner. This scanner provides maximum processing capacity for symbols in any position at very high speed, particularly on conveyor belts where code size and position are unpredictable. Price is high, but product ensures high productivity beyond bar code orientation.

Raster-Scan. This scanner provides very high speed symbol processing at significantly lower costs but requires symbol orientation so that scanner beam can face a whole set of bars. Scanner performs up to 1 meter scanning at high speed.

Single Line Scanner. This is a medium-speed scanner for low-speed conveyor belts. The price is low when compared to other automatic fixed scanners, and this scanner provides good field depth. Symbol positioning on the item becomes critical for scanner.

Scanning can enable retailers to literally control the flow of merchandise to their stores, allowing reordering as necessary. Current POS technology can now give headquarters the same information overnight, giving a whole new meaning to rapid replenishment. Rapid replenishment has reduced the order-to-cash cycle to a minimum.

#### Section 4 - Electronic Ordering Systems

During the early period of the development of information systems in the distribution industry, such systems were mainly concerned with efforts to save labor and raise efficiency by receiving and placing orders electronically. The first system that the

distribution industry installed was the Electronic Ordering System (EOS). Electronic Ordering System (EOS) combines computer and communication technologies, and adapts electronic data interchange (EDI) paths in order to replace traditional ordering system. The EOS is an automated ordering system facilitated by EDI-capable computers and networks.

System Definition. The narrow definition of EOS is a retailer placing an order to the wholesaler through the EDI network. The broad definition will include all commercial transactions: placing order, receiving and inspection, auditing, and fund transfer (MOEA, 1995). EOS has become an indispensable information system of enabling just- in- time delivery of various items in small quantity and within a short time cycle. Advanced businesses are promoting the further development of store information, such as an automatic supplementary ordering system linked to point of sale (POS) sales information (Kida, 1991).

In the advanced enterprises, the integration of customer management information systems is being promoted through various POS systems. From the standpoint of the supply chain management, the standardization of the communication protocol and of various business protocols is inevitable.

No longer is the salesperson required to be a physical conduit for order information. The order may bypass the salesperson and flow directly from the buyer's ordering/inventory system into the seller's order processing system. This process is usually much less time consuming. Consequently, the salesperson has the potential of managing and servicing more customers than possible under a paper-based system (Hill, 1994).

How EOS Works. In an EDI network, a buyer scans an electronic catalog maintained by a supplier and selects a product. An electronic purchase request compiled in accordance with the buyer's internal procedures and buying practices is transmitted directly to the factory or warehouse (distribution center) of the supplier via a third-party network, also known as a value-added network(VAN). The network acts as an electronic mailbox for sending and receiving order and delivery messages. The network can also translate and secure the information until the appropriate party's system retrieves the message (Figure 7).

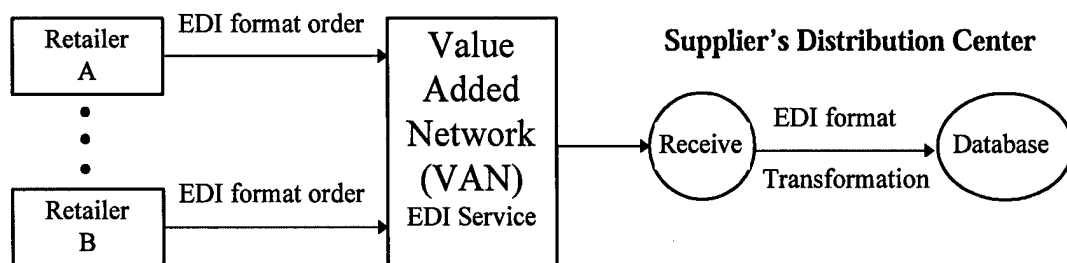

Figure 7. Electronic Ordering System

Third party networks serve as electronic data interchange service bureaus, in addition to providing “mailbox” service available from value-added networks. The service bureaus would act as an EDI network for Just-in-Time (JIT) manufacturer's and their suppliers, receive transaction sets in many different protocols, and translate these transactions to the JIT manufacturer's protocols. These networks take responsibility for all communication needs. The third party networks reformat transactions to meet different standards, formats or conventions, or even provide communication links and transmission of electronic documents to and from various transportation companies.

Value-added networks provide “mailbox” service for the JIT manufacture and supplier companies. All companies are responsible for developing protocols and format handling requirements, but contract with a public network such as Tymnet or MCI to act as a communication carrier. The carrier provides “mailboxes” where electronic documents may be stored for all companies. The “mailbox” makes it unnecessary for the companies to provide a dedicated computer for the purpose of awaiting incoming calls (Lankford & Riggs, 1996).

Items procured through the EDI link are electronically selected from the supplier’s inventory and sent directly to the distribution centers based upon previously established just-in-time inventory stocking rules maintained by the chain’s procurement staff. No mailing costs for order and delivery paperwork are incurred, and each step in the process can be completed in minutes, often without human intervention.

A study by IBM (Tobey, 1996) found that moving toward electronically coordinated purchasing systems could save an organization as much as 60 percent by eliminating “maverick” purchases—those made outside the negotiated vendor agreements. A study by Intersearch (Tobey, 1996) found that on-line purchases of products resulted in a cost savings of 22 percent to 25 percent compared to manual methods. As a result, more than 88 percent of the companies surveyed by IBM plan to re-engineer their procurement processes. However, the most common first step in re-engineering procurement is to implement an electronic catalog and ordering system (Tobey, 1996).

Value-Added Networks (VANs). A VAN is a communications network that typically exchanges EDI messages among trading partners. It also provides other services, including holding messages in “electronic mailboxes.” interfacing with other VANs, and

supporting many telecommunications modes and transfer protocols. A VAN's "electronic mailbox" is a software feature into which a user deposits EDI transactions and then retrieves those messages when convenient. It works much like residential personal mailboxes, and it allows everybody involved to be flexible and cost-effective.

Businesses can exchange data either by connecting to each other directly or by hooking into a VAN. Traditionally, by acting as middlemen between companies, VANs have allowed companies to automatically and securely exchange purchase orders, invoices, and payments. When a company sends an EDI transaction, it arrives at a message storehouse on the VAN to await pickup by the destination company. In this way VANs can safeguard the transaction network.

Figure 8 illustrates the EDI process. Company A puts an EDI message for trading partner manufacturing company B in the VAN mailbox at a date and time of its choosing. The VAN picks up the message from the mailbox and delivers it to trading partner B's mailbox, where it will remain until trading partner B logs on and picks it up. Trading partner B responds to trading partner A in the same fashion. The cycle repeats itself on a weekly, daily, or perhaps even hourly basis as needed. This service is generally referred to as mail-enabled EDI.

Trading companies can establish an electronic mailbox on a VAN and require each trading partner to use the VAN for sending and retrieving EDI messages. This alternative works well because most VANs require each trading partner to use the VAN for sending and retrieving EDI messages. This alternative works well because most VANs maintain a large number of access points (nodes) to their networks and can spread the

costs of maintaining these ports among their clients. Thus a large number of trading partners can access the VAN at their clients. Thus a large number of trading partners can access the VAN at their convenience without encountering blockage from other trading partners and at relatively cost.

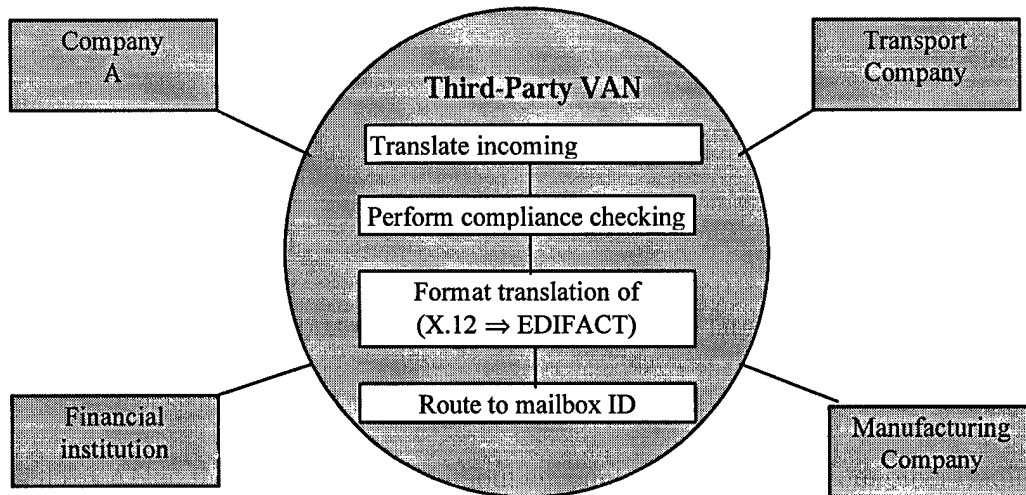

Figure 8. Functions of a Third-Party VAN (Kalakota & Whinston, 1996)

Large EDI-capable businesses and government agencies with more than a handful of trading partners almost always rely on VANs, and small organizations with six or more trading partners are good candidates for using VANs, as are organizations with minimal internal expertise regarding computers, modems, telecommunications, and EDI. Many businesses find that the decision to use a VAN is made for them by their trading partners. An organization selecting a VAN should consider the VAN's reputation and experience, level of technical support and service capacity, and ability to cope with network outages.

Other factors include whether the VAN operates its own communications network or leases capacity from a network provider, what are the means of connectivity to the VAN, and what are the costs.

VAN Third Parties. A wide range of VAN providers exist. Some provide only the network for electronic communications, and others also provide such services as customizing vendor profiles to screen procurement data.

EDI Gateways. The increase in transaction volumes and types of standards and communication protocols possible between organizations has brought to the fore the issue of managing communication among a multitude of ad hoc and often incompatible application systems, protocols, communications methods, and data standards. In response, EDI gateways are being built that act as communication hubs between different sections of the same organization or with outside trading partners.

Gateways are necessary when using multiple standards. Common gateway facilities include (Kalakota & Whinston, 1996):

- EDI message construction and translation
- Translation between application software package standards and some agreed-on in-house standard
- Translation between the in-house standard and the various EDI document formats (such as ANSI X.12 or UN/EDIFACT)
- Queue management for both inbound and the various EDI document formats (such as ANSI X.12 or UN/EDIFACT)

- Queue management for both inbound and outbound documents
- Compliance checking of arriving messages to ensure correctness
- Transmission between the organization's internal data communications standards (X.400 or a local area network standard such as IEEE 802.3) and those of the recipient, who may be a value-added network service provider (in which case X.25 would be the most likely standard) or a trading partner (who might well be using X.400 messaging)
- Session management and directory services maintenance
- Full delivery audit facilities
- Security and management features
- Call-logging facilities designed to enable operation of a service desk
- The creation of trading partner relationships and the establishment of trading partner profiles
- A variety of optional additional services, such as support for interactive database queries

While many US companies operate on a single standard, an increasing number of global trading partners are realizing that some use of EDIFACT will be a requirement in the near future. Discovering that you need to use multiple standards should not present a significant roadblock to implementing EDI. Many companies select translation software that accepts a variety of standards. One EDI translation application allows company X to send and receive documents in any standard. Another answer is gateways. A gateway provides a trapdoor for documents that require a different standard. It transforms an ANSI transaction into an EDIFACT message (Kalakota & Whinston, 1996).

## Chapter Summary

This chapter provides a frame work on EDI, Bar Code System, and EOS information technologies, which are used by supply chain management. This research attempts to examine EDI and bar code information technology further by studying a Taiwan company, while examining the effect on supply chain management. The case study for this research is presented in the next chapter.

## II. A Case Study: The Implementation of the Electronic Ordering Information System

### Chapter Overview

This chapter presents a case study which examines the effects of implementing an EDI and barcoding information system and its resulting impact on organizational processes within the Kang Kuo Company in Republic of China (ROC). EDI and barcoding provide information linkages between selling firms and buying firms and offer significant benefits for participating companies. This chapter exams the company background, innovations with information technology, the issues, and impacts of the implementation.

### Background

The Kang Kuo Company, founded in December 1986, is one of the largest, most successful distributors of dry goods and merchandise for grocery stores, supermarket, food retail chains, and also non-food stores in Taiwan. By 1996, Kang Kuo had contracted 1950 chain stores, including supermarket chains, Department store chains and mass sales stores. These chain stores are almost all located in densely populated areas throughout the island. They had total sales of approximately US\$ 38.6 million in 1992, US\$ 56.9 million in 1994, and US\$ 83.3 million in 1996. Consequently the company achieved, on the average, a 20 percent growth in annual sales. It has become the industry leader in adopting information technology for gaining a competitive edge and reducing overhead costs (MOEA,1996).

### Company's Positioning, Role, and Functions

The Kang Kuo Company functions as a wholesaler by purchasing grocery products from hundreds of different manufacturers, and then, sells and distributes these products to many different retailers (Figure 9). Its role is to cut the selling and buying paths, reduce the costs incurred between both paths, and create the highest profitability in the entire sales activities. In addition, the strategic goal of Kang Kuo is to achieve professional, centralized, and efficient management (Cheng, 1997).

Kang Kuo serves as a wholesaler which has five distribution centers (DCs) island-wide. It stocks about 3,000 items ranging from general food items to consumer sundries. Most of the products are purchased from hundreds of suppliers or manufacturers and all products are shipped to the distribution centers (DCs) and then sold to the appropriate retail stores according to the purchasing orders. Kang Kuo intends to integrate their supply chain because of the tremendous varieties of merchandise (Cheng, 1997).

Integration of the logistics process within the supply chain encountered many difficult problems. Most consumer and industrial products are not totally created by a single firm. Normally, several independent firms are involved in manufacturing a product and placing it in the hands of the end user. One firm might produce a raw material and sell it to a second firm which uses the material to produce a component and assemble it into a product which is sold to a fourth firm such as the Kang Kuo Company - a wholesaler. The wholesaler in turn sells the product to a fifth firm, such as a retail merchant, and the fifth firm sells the product to a consumer. The set of firms which pass these materials forward can be referred to as a supply chain.

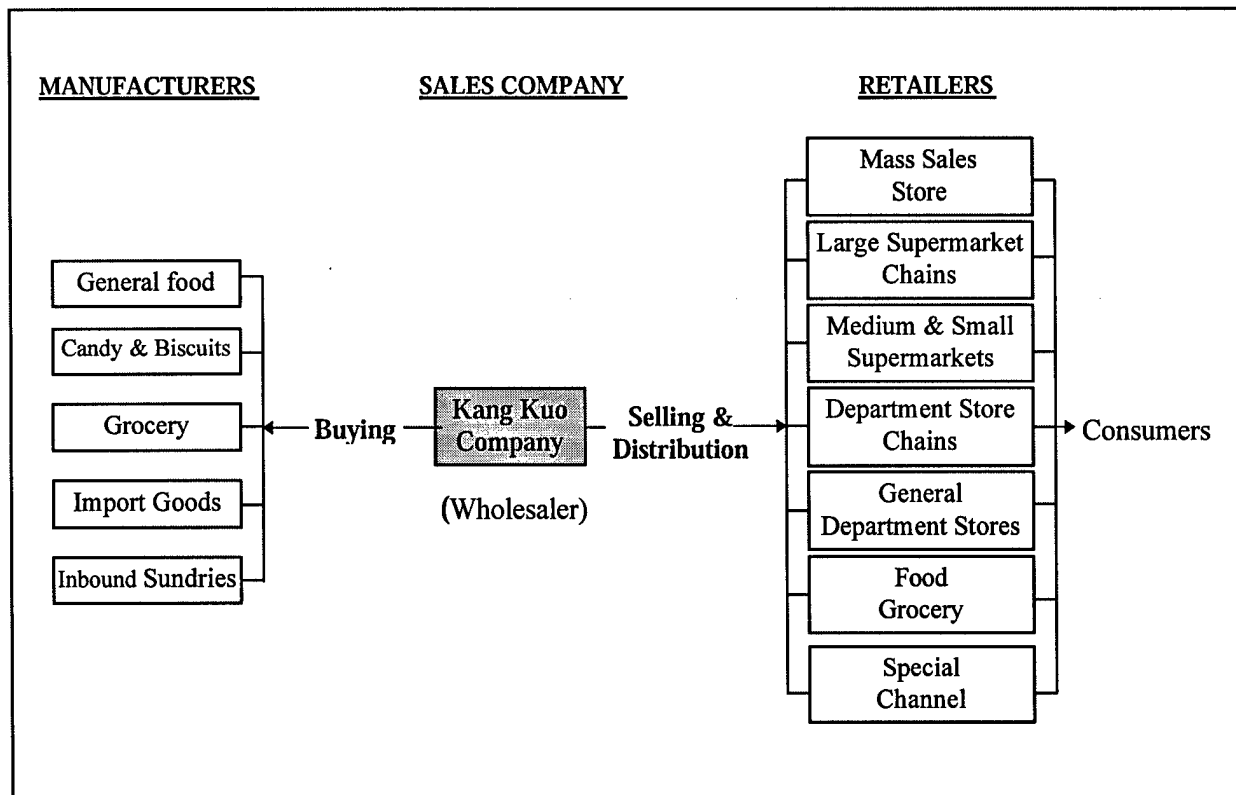

Figure 9. Kang Kuo Company's Supply Chain

There exists a competitive need to increase the overall efficiency and effectiveness of the supply chain as a whole by practicing information management of the flow of merchandise throughout the entire supply chain. The Kang Kuo Company decided to adopt the QR strategy of applying information management to all the elements of a supply chain and called this strategy "Supply Chain Integration" (Cheng, 1997).

Traditional Ordering Process. Before 1987, Kang Kuo used a traditional order cycle: a salesperson would call on a retail store, in person or over the phone, and write up a detailed order from the retailer. The sales person would then phone in the order to a Kang Kuo distribution center and verbally read out stock numbers and quantities to an order clerk. Within a few hours, the order would be manually picked and shipped out by

truck or other means. The time from order to delivery required about 10 hours or longer for merchants geographically distant from a distribution center (Cheng, 1997).

Kang Kuo saw opportunities for improvement in several areas. First, retail stores could order just as easily from any of a number of distributors. There was no particular loyalty to any one distributor. Prices were very similar across distributors and all distributors sold the same manufacturers' goods. However, the ordering process was time consuming. Much of a sales call focused on writing up the order and discussing problems in past invoices. Between the distribution center order clerk and salesperson, considerable time was spent relaying the order over the phone(Cheng, 1997). Therefore, customer-responsive information, Quick Response (QR), played a key role in determining where a retail store's order was sent. Second, orders frequently had errors. Errors occurred at several possible stages:

- the salesperson wrote down the wrong stock number or
- misread the number over the phone;
- the order clerk misheard or miswrote a stock number or
- an order picker misread the handwritten picking order produced by the order clerk.

In the highly competitive wholesale grocery industry with low profit margins, errors are expensive and customers can easily take their business elsewhere. In addition, return item processing took a significant amount of time in a sales call. Sometimes a salesperson would spend 70 percent of a sales call filling out forms and inspecting products and records to process a return shipment. Therefore, Kang Kuo wanted to

implement an information system that would help lock in customers and reduce errors inherent in the paper-based system (Cheng, 1997).

Early Efforts at Computerization. In 1987, the Kang Kuo Company implemented an internal EOS system, and the format for internal ordering information was standardized. The orders were received by the cooperate headquarters via EOS , and then they were recorded, approved and forwarded to the DCs. After the order-picking operations in the DCs, the ordered items were distributed to the associated retail stores. An order clerk was no longer needed to write up the order, and, since the order was computerized, it could be sorted in the pick sequence of the warehouse thereby simplifying the picking process (Cheng, 1997).

However, the order processing with suppliers (manufacturers) and retailers was still cumbersome. Because the concept of EOS was not accepted by most of the suppliers and retailers at that time, the company reported that it took almost two years to improve this situation (Cheng, 1997).

Linking to the External EOS System. By 1989, several famous retailers had centralized their integrated computer systems. Although they began to implement the EOS system, unfortunately, there were no standardized formats to be used. Under this circumstance, Kang Kuo had to link each retailer separately. In other words, the company developed more than 10 different EOS formats in order to accomplish each one-on-one link. Although the tasks of the links were complicated, but also increased the maintainability for the EOS system, the problems of ordering and distribution between the suppliers and retailers were solved. At the end of 1994, more than seven famous

supermarkets had implemented EOS systems and were linked with Kang Kuo (Cheng, 1997).

### Innovations with Electronic Ordering

Barcoding, Scanning, and POS. The Kang Kuo Company persuaded the manufacturers to add a bar code label on each stocked product. The retailers began using a hand-held scanner to read bar coded shelf labels. So a light hand-held scanner can read the label and the person ordering simply had to key in the quantity ordered. The accuracy of the scanning process was very high almost 100%. Studies indicate that manual data entry produces roughly one error in every 300 keystrokes, while bar-code devices generate only one error in every three million transactions (Bowen, 1995).

Most retailers now have micro computers, so the hand-held scanner is able to download the order to the PC or send it directly to Kang Kuo. The PC delivers the order through a modem to Kang Kuo and receives back a detailed confirmation of the order. If any products cannot be supplied, the retailer knows immediately to order the unavailable items from another supplier. In addition to ordering, the retail stores can also gather inventory information through the scanner and transmit stock numbers and quantity to Kang Kuo. The firm then sends back to the retail stores a completely priced out list of inventory.

When the suppliers of the Kang Kuo Company implemented barcoding, much redundant work was eliminated from the purchasing cycle. A bar code is submitted to a retail store's requisitioner, That person simply "wands" the bar code, inputting to the

computer a part number, price, and all POS information pertinent to that product. The requester does not even have to key-in the requisition.

Before 1993, the percentage of use of the EAN/UPC was not high because most retail stores conventionally used the company-specific in-store codes. This situation was an impediment to the widespread use of POS systems. According to the Taiwan Institute of Information Industry, by 1993 over 3,300 companies and 130,000 products had EAN/UPC tags attached or printed on the packages of goods. It is expected that by 1997 the proportion of stores applying EAN/UPC to the food products, groceries and commodities will reach 90 percent, as compared with 70 per cent at the end of 1993.

Barcoding of products is the first step towards store automation. Store automation led by Point Of Sale (POS) systems has become indispensable for the information management strategies of the Kang Kuo's distribution centers. The EAN/UPC data and price list are regularly provided by the mainframe in the corporate headquarters. In each retail store, a super-micro or minicomputer that monitors the POS terminals maintains the EAN/UPC database and price list. Almost all sales information can be gathered by the front POS (FPOS) system in a more timely and accurate way. The rear POS (RPOS) system analyzes sales information from the FPOS system, prints out the EAN/UPC bar codes, manages goods by product and places electronic orders. In addition, the RPOS system handles merchandise receiving and inspection, inventory control, physical counting, accounting and vendor management.

The Standardization of the EOS Format. In 1994, Taiwan Industrial Technology Research Institute, Computer & Communication Laboratories had successfully developed

the standardized EOS system for the purpose of unifying the different standards. The Institute, sponsored by the Ministry of Economic Affairs (MOEA) in ROC, also has the responsibility to facilitate commerce automation through the adoption of the EOS system. In the meantime, the third party EDI network company, the Vanguard Information Group (VIG), the Vanland Inc., also provided the VAN for the usage of mail boxes in the EDI network.

Next, the Kang Kuo Company installed a fully integrated electronic procurement management system, the Electronic Ordering System (EOS) (see Figure 10), to provide an integrated system to process satisfactorily all the information needed. Orders enter EOS from the computer systems of retailers needing supplies. Authorization takes place electronically, and the order then passes to the purchasing department. The EOS system is paperless, with purchasing orders appearing on-line or sent electronically by EDI or fax. Processing has been reduced from tedious steps to only five:

1. electronic input of POS purchase requisition
2. electronic authorization
3. purchase order completion by purchasing department
4. electronic reception of deliveries
5. electronic payment order to bank

With the EOS system, handling time has been cut in half and processing time for a complete order has dropped from 4 working days to only 4 hours (Chang, 1997). In the two years to September 1996, Kang Kuo increased its sales from \$56 million to 83 million (increased about 50%), and purchasing department's efficiency 20 times with increasing ordering from 15,000 to 300,000 per month, while lowering procurement costs by 30%.

Also, due to decreasing key-in personnel, Kang Kuo can save both the direct and indirect labor cost by about \$110,000 every year (MOEA, 1996).

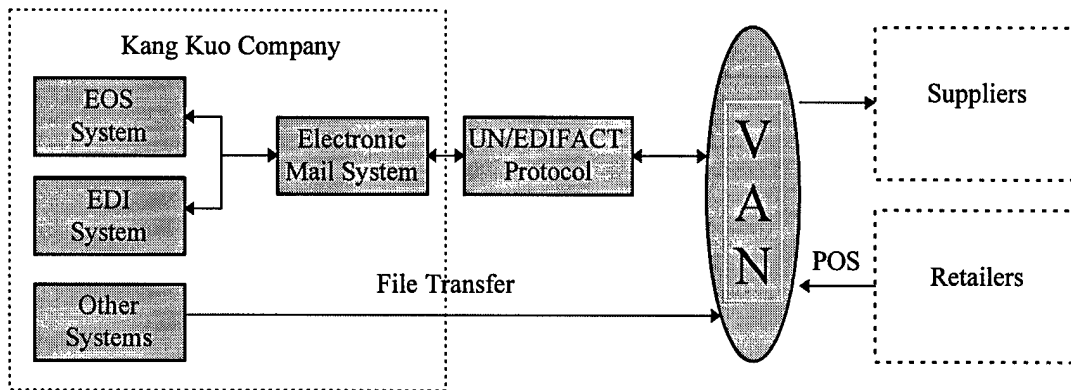

Figure 10. The Kang Kuo Company's EOS & EDI System

Generally, an EOS system comprises a variety of components: corporate headquarters; retail stores; distribution centers (DCs); suppliers; manufacturers; networks; information service providers; insurers; and bankers. Figure 11 presents the Kang Kuo Company's information and merchandise flow.

Information Flow. The mainframe in the headquarters maintains all records of the current stock levels at each DC. Thus, purchase orders can be transmitted directly and accurately from the mainframe to the computers of the vendors. On the other hand, the POS terminals in each store are connected to an in-store micro or mini computer. The store computer is then connected to standard telephone lines or leased lines and can be accessed directly by the Kang Kuo's mainframe.

The third party network and information service provider, the Vanguard Information Group (VIG), offered Kang Kuo an "End-to End Solution" to solve Value-

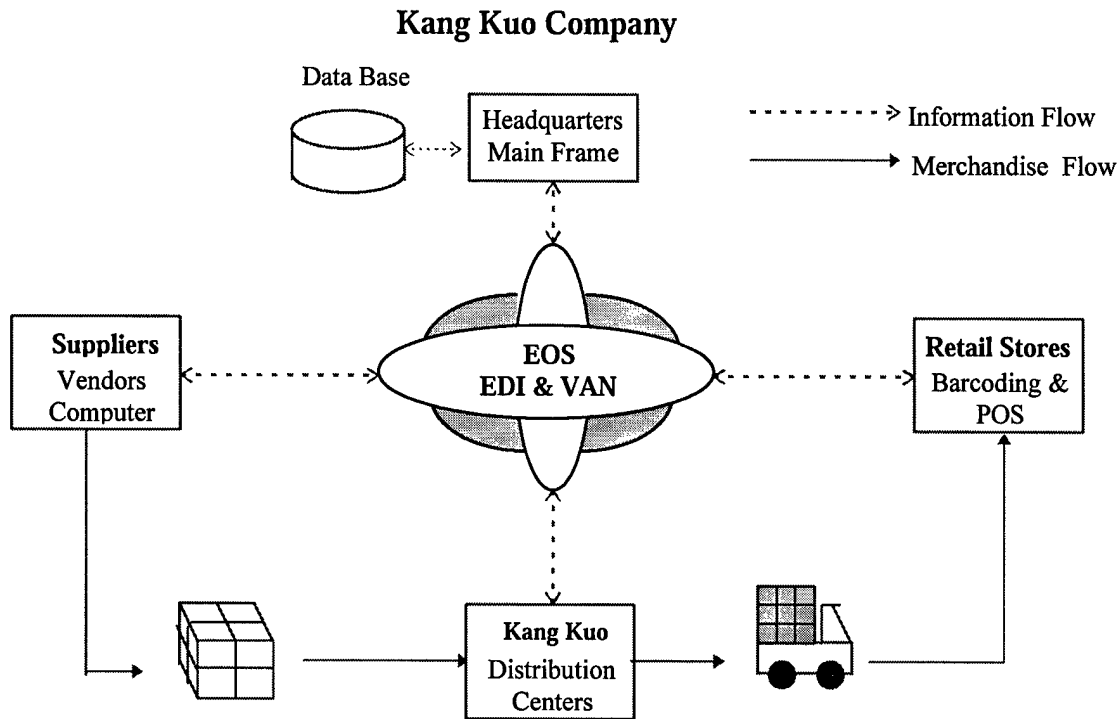

Figure 11. The Kang Kuo Company's Information & Merchandise Flow

added Network(VAN) requirements and services. Through VIG's EDI, Electronic Mailboxes, and advanced fax products and services, Kang Kuo can communicate with local and international vendor and suppliers.

The VIG's VAN services enable computers to communicate without having to worry about particular communication parameters or rules. Electronic mailbox services operate like an electronic post office, enabling companies to exchange data at their convenience, without having to connect directly.

Through the electronic mailbox services, the Kang Kuo Company can upload a batch of addressed documents to the VAN network. The network provider sorts the transactions and delivers them to the trading partners' (manufacturers, suppliers, and retailers) mailboxes, from which the documents can be downloaded at the receiver's

convenience (Chen, 1997). Kang Kuo can also download documents received from its trading partners at the same time. Not only does this allow for more convenient and efficient exchange, but it allows for “one-step shopping” - one connection takes care of all transmission with all trading partners using that VAN.

Kang Kuo sells merchandise to over 2,000 retail stores in the ROC, and carries a wide variety of general consumer goods. Their distribution system has various features including:

- diversified products;
- short order cycle times;
- shipping in small quantities;
- high frequency and reliability of deliveries;
- customer service orientation;
- low stock level and rapid inventory turnover; and
- timely and accurate information requirements.

There is an urge to implement Quick Response (QR) in a general retail environment. However, some of the manufacturers do not barcode all items. Also, some of the retailers do not capture the Point-Of-Sale (POS) on all transactions. Therefore, daily sales and inventory data on specific items are only shared with key vendors or retailers who participate in the quick response programme.

Merchandise Flow. Kang Kuo does not permit automatic replenishment, but it does guarantee the vendor that a weekly order will be placed. Since the vendor has access to the inventory objectives, on-hand inventory, and actual sales data for the entire

firm, the vendor can readily anticipate the size of the order and can use this information in its production and distribution planning.

Once each week the actual order is made and the vendor ships to each of Kang Kuo's four distribution centers, with products to arrive within one week. Once the product arrives at the distribution centers, Kang Kuo management has an additional week's worth of sales data to consider and then sends replenishment shipments to each store. Thus the store will receive a replenishment shipment for each item each week based on a two-week cycle to the vendor.

#### Lessons and Implications From Kang Kuo

The Kang Kuo Company has embraced and employed supply chain management and Quick Response strategies in their logistics operations with dramatically positive results. However, not all such attempts have been successful, nor has every implementation proved straightforward or simple. In this section, we will offer a list of observations and conclusions we have drawn from our studies of the Kang Kuo Company.

Emerging SCM and QR. Supply chain management and Quick Response are complementary strategies. The strategies so frequently are seen together that it can be difficult to distinguish between them (La Londe & Masters, 1994). In the discussion of supply chain management at the Kang Kuo Company presented earlier for example, the ordering cycle time was dramatically reduced with the new EOS procedures. This "Quick Response" information technology is often thought of as inventory control procedures and

is often compared with the just-in-time procedures widely used in material management systems for production facilities.

In a typical quick response environment , a retailer and a manufacturer agree to closely co-ordinate the deployment and control of retail inventories (La Londe & Masters, 1994). Key components of such systems usually include:

- The retailer captures accurate and timely sales data, typically via POS scanning of barcoded merchandise.
- Sales and inventory data are shared on a weekly or daily basis with the manufacturer via EDI transmission.
- The manufacturer is authorized to initiate automatic or nearly automatic stock replenishment action against pre-established target inventory levels.

In the discussion of Quick Response to the extreme limit, one might have stressed the high degree of co-ordination and co-operation between the end-user and its vendor base which was needed to achieve the desired cycle time compression. A principal reason to develop supply chain management is often to capture and amplify the benefits of cycle time compression by applying the strategy at all levels in the supply chain.

Information Technology - The Key Enabling Technologies The Kang Kuo Company uses barcoding and POS scanning to provide input of the transaction data on sales, inventory, and shipments. Data are normally telecommunicated between various operating locations, usually by EDI and the third party VAN. In addition, the EOS system guided the operation of the QR strategy. Therefore, major improvements are being made in the Kang Kuo's distribution system in the area of information processing. The application of QR strategy and POS systems are optimizing store inventories,

strengthening affiliation with vendors and plants, and reinforcing overall control of the distribution system. These methods of merchandise management give power to retailers to control wholesalers and physical distribution activities, rather than the reverse, which has traditionally been the situation in Taiwan.

Uncertainty in Supply Chain Improved. Before implementing the innovations, Kang Kuo could not efficiently manage demands requirements. Kang Kuo relied on a Just-in-case system by creating buffer caches of work, information, cash, and even workers to compensate for unexpected demand requirements. The conventional reaction to Just-in-case inventory is to create better inventory management tools (Hammer, 1993). However, Kang Kuo integrated the supply chain and removed the organizational uncertainty by using POS and EDI information technologies. Implementing this electronic ordering system involves retailers knowing the rate of turnover for their store's product range, and Kang Kuo can process orders to match actual retail sales instead of estimated.

Productivity in EDI Information Flow. Tough competition demands EDI information systems that support quick order cycle time within the supply chain because the number and variety of merchandise are constantly changing and increasing. This applies to both wholesales such as Kang Kuo, with millions of order lines each year, and to specialized trading partners within the supply chain where every order line can be worth many thousands of dollars. A study entitled "Managing Price, Gaining Profit." published in the Harvard Business Review, shows what an impact this can have. Based on data received from 2,463 companies, the authors show how a 1 percent improvement of the average price level translates into an 11 percent improvement in the operating profit. This

amounts to three times the effect of an equivalent 1 percent increase in sales volume (Carlberg, 1994).

New Approach - Efficient Consumer Response (ECR). Kang Kuo views the supply chain as a single entity rather than relegating fragmented responsibility for various companies in the supply chain to functional areas such as manufacturing, purchasing, distribution, and sales. While strategies vary from company to company, the overall objectives of a reinvented chain are clear: to become increasingly responsive to customer needs, drive costs out of the system and turn savings into additional value for the consumer.

Therefore, Kang Kuo's supply chain requires a new approach - ECR to systems. ECR will integrate the supply chain vertically, not only focusing on individual cost reduction, but also emphasizing on overall costs and market shares in the supply chain. Figure 12 shows ECR vertical integration in supply chain.

ECR will ensure strategic linkages, emphasize process over functional orientation, and achieve efficient replenishment through information sharing on a real time basis. In other words, ECR integration is what makes a reinvented supply chain work. The boundaries that used to separate players in the chain are blurring and increasingly, processes overlap. That means all components of the chain must be integrated against the common goal of serving the customer and have a stake in product development, marketing, networking replenishment and product flow.

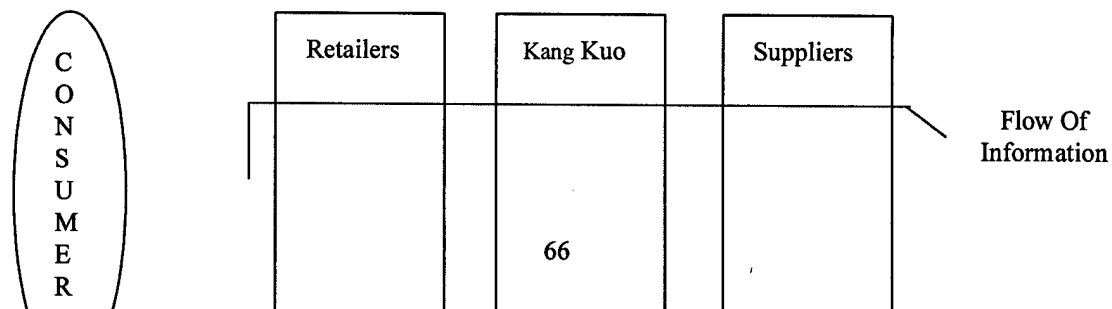

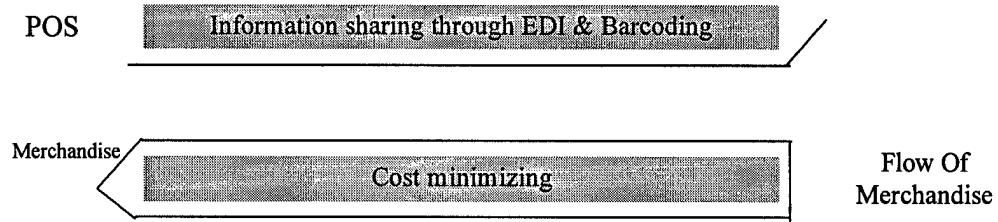

Figure 12. ECR Vertical Integration in Supply Chain.

### Chapter Summary

This case study of the Kang Kuo Company provides insights into the use of information technologies through the supply chain in a Taiwan company. By implementing EDI, Barcoding, POS, EOS systems, the Kang Kuo Company has embraced the supply chain management and Quick Response strategies to boost their competitiveness, productivity, and profitability.

### IV. Analysis

#### Chapter Overview

This chapter examines the research findings at each phase of the case study presented in chapter 3 and analyzes the impacts of information technology adoption in the supply chain.

#### Research Findings

The case study of the Kang Kuo Company, wholesaler, does indicate that two fundamental logistics strategies are emerging: Supply Chain Management (SCM) and

Quick Response (QR). Kang Kuo is using these strategies to deal with the challenges in the logistics environment and achieve their long-term objectives of market share and profitability. Supply chain management involves expanding the integrated logistics concept beyond the corporate borders of the firm to include the logistics operations of suppliers and retailers. The second strategy, Quick Response (QR), involves managing both the flow of material and the flow of information so as to minimize the time needed to respond to customer demands. In the case study answered in Chapter 3, these two basic strategies are being successfully implemented in the Kang Kuo Company by using EDI and barcoding information technologies. The remainder of this chapter will examine implementation issues of the Kang Kuo company, and the analysis of the results.

#### Motivations to Implementation

Not only Kang Kuo but also all firms across all industries have sought profitability in the past decade by cutting cycle times and inventory. From product sourcing and development to delivery, speed is essential to compete in today's environment. Kang Kuo aimed at cutting inventory cost and cycle times. They have embraced the QR strategy and implemented EDI and barcoding information technologies. With Quick Response, the manufacturer and the retailer's cash register data coordinates the flow of inventory from DC to the retail store. The QR approach to stock replenishment boosted sales and of course, profitability and competitiveness.

### Benefits of Electronic Ordering

Once in place, EDI and barcoding offers users a variety of benefits (Table 3 Benefits to implementation), the first of which is financial savings. The most significant case of financial savings is cycle time compression, which will include inventory reduction. Generally, inventory reduction will be one item on the list of benefits, cost savings which were sought or obtained. Because data is transmitted directly to the user's application system, the cost of rekeying, paper handling, and error resolution is eliminated. No longer is catalog, price, and technical information transported to the buyer through a salesperson. This information is exchanged between computer systems. Price information, for example, can be accurately and quickly transferred, without a salesperson, from the seller's computer system to the potential buyer's computer system.

Table 3. Benefits to Electronic Ordering Implementation

Electronic Ordering	Benefits
1. Cycle time compression and Process automation	1. Inventory and administrative overhead reduction and cost saving
2. EDI format document	2. time saving and improved accuracy
3. enhanced communication and the sharing of information	3. improved trading partnership
4. improved POS	4. improved forecasting

Using EDI has the effect of eliminating much of the human communication errors such as price quote errors due to rekeying, mishearing, miswriting, and misspeaking data. Personnel can then be reassigned to areas of greater productivity for savings of human and financial resources.

Increased employee productivity results in excess capacity, which makes it possible for a company to expand or grow. This has been proved by Kang Kuo's net sales, which have been growing dramatically, since implementing the electronic ordering system. The sales amount of Kang Kuo in recent years is shown in Figure 13. An interesting observation is that the more automatic the processes become, the less the need for layers of middle management (MOEA, 1996). Thus, it is possible to reduce administrative overhead costs. In any case, the result is increased income per employee.

