

FINAL REPORT
OCTOBER 1996

REPORT NO. 96-71

STEEL STRAPPING EVALUATION

19970707 094

Prepared for:
U.S. Army Armament Research,
Development and Engineering Center
ATTN: AMSTA-AR-ESK
Rock Island, IL 61299-7300

Distribution Unlimited

DTIC QUALITY INSPECTED 3



VALIDATION ENGINEERING DIVISION
SAVANNA, ILLINOIS 61074-9639

AVAILABILITY NOTICE

A copy of this report will be furnished each attendee on automatic distribution. Additional copies or authority for reprinting may be obtained by written request from Director, U.S. Army Defense Ammunition Center, ATTN: SIOAC-DEV, Savanna, IL 61074-9639.

DISTRIBUTION INSTRUCTIONS

Destroy this report when no longer needed. Do not return.

Citation of trade names in this report does not constitute an official endorsement.

The information contained herein will not be used for advertising purposes.

UNCLASSIFIED

SECURITY CLASSIFICATION OF THIS PAGE

REPORT DOCUMENTATION PAGE				Form Approved OMB No. 0704-0188	
1a. REPORT SECURITY CLASSIFICATION UNCLASSIFIED			1b. RESTRICTIVE MARKINGS		
2a. SECURITY CLASSIFICATION AUTHORITY		3. DISTRIBUTION / AVAILABILITY OF REPORT			
2b. DECLASSIFICATION / DOWNGRADING SCHEDULE		UNLIMITED			
4. PERFORMING ORGANIZATION REPORT NUMBER(S) 96-71			5. MONITORING ORGANIZATION REPORT NUMBER(S)		
6a. NAME OF PERFORMING ORGANIZATION U.S. Army Defense Ammunition Center		6b. OFFICE SYMBOL (if applicable) SIOAC-DEV	7a. NAME OF MONITORING ORGANIZATION		
6c. ADDRESS (City, State, and ZIP Code) ATTN: SIOAC-DEV Savanna, IL 61074-9639			7b. ADDRESS (City, State, and ZIP Code)		
8a. NAME OF FUNDING / SPONSORING ORGANIZATION U.S. Army Armament Research, Development and Engineering Center		8b. OFFICE SYMBOL (if applicable) AMSTA-AR-ESK	9. PROCUREMENT INSTRUMENT IDENTIFICATION NUMBER		
8c. ADDRESS (City, State, and ZIP Code) ATTN: AMSTA-AR-ESK Rock Island, IL 61299-7300			10. SOURCE OF FUNDING NUMBERS	PROGRAM ELEMENT NO.	PROJECT NO.
			TASK NO.	WORK UNIT ACCESSION NO.	
11. TITLE (Include Security Classification) Steel Strapping Evaluation					
12. PERSONAL AUTHOR(S) Bradley J. Haas					
13a. TYPE OF REPORT Final		13b. TIME COVERED FROM _____ TO _____		14. DATE OF REPORT (Year, Month, Day) 1996 October	15. PAGE COUNT
16. SUPPLEMENTARY NOTATION					
17. COSATI CODES			18. SUBJECT TERMS (Continue on reverse if necessary and identify by block number)		
FIELD	GROUP	SUB-GROUP			
19. ABSTRACT (Continue on reverse if necessary and identify by block number) The U.S. Army Defense Ammunition Center (DAC), Validation Engineering Division (SIOAC-DEV), was tasked by U.S. Army Armament Research, Development and Engineering Center (ARDEC) to perform salt-fog accelerated-aging testing on 1-1/4-inch steel strapping to determine whether Delta, style III, painted seals are a suitable alternative to currently utilized seals. It was concluded that the Delta, style III, painted seal meets the minimum requirements of ASTM Designation: D 3953-91 and performs as well as currently utilized seals.					
20. DISTRIBUTION / AVAILABILITY OF ABSTRACT <input checked="" type="checkbox"/> UNCLASSIFIED/UNLIMITED <input type="checkbox"/> SAME AS RPT. <input type="checkbox"/> DTIC USERS			21. ABSTRACT SECURITY CLASSIFICATION UNCLASSIFIED		
22a. NAME OF RESPONSIBLE INDIVIDUAL JEROME H. KROHN		22b. TELEPHONE (Include Area Code) 815-273-8929		22c. OFFICE SYMBOL SIOAC-DEV	

DD Form 1473, Jun 86

Previous editions are obsolete

SECURITY CLASSIFICATION OF THIS PAGE

DTIC QUALITY INSPECTED 8 i

UNCLASSIFIED

U.S. ARMY DEFENSE AMMUNITION CENTER
VALIDATION ENGINEERING DIVISION
SAVANNA, IL 61074-9639

REPORT NO. 96-71

STEEL STRAPPING EVALUATION

TABLE OF CONTENTS

PART	PAGE NO.
1. INTRODUCTION	1-1
A. BACKGROUND	1-1
B. AUTHORITY	1-1
C. OBJECTIVE	1-1
D. CONCLUSION	1-1
2. ATTENDEES	2-1
3. TEST PROCEDURES	3-1
4. TEST EQUIPMENT	4-1
5. TEST RESULTS	5-1
6. PHOTOGRAPHS	6-1
7. GRAPHS	7-1
8. APPENDIX	8-1

PART 1

INTRODUCTION

A. BACKGROUND. The U.S. Army Defense Ammunition Center (DAC), Validation Engineering Division (SIOAC-DEV), was tasked by the U.S. Army Armament Research, Development and Engineering Center (ARDEC) to perform tension testing on 1.25-inch steel strapping specimens subjected to various increments of accelerated aging to determine the suitability of employing style III seals. Additional strapping samples were provided by Iowa Army Ammunition Plant (IAAAP) for the purpose of comparison to test results provided.

B. AUTHORITY. This program was conducted IAW mission responsibilities delegated by the U.S. Army Armament, Munitions and Chemical Command (AMCCOM), Rock Island, IL.

C. OBJECTIVE. To verify that the Delta style III painted seal meets the requirements of ASTM Designation: D 3953-91 and performs comparably to currently accepted seals.

D. CONCLUSION. The Delta, style III, painted seal meets the requirements of ASTM Designation: D 3953-91 and performs as well as currently accepted seals. All straps and seals tested also meet the minimum requirements of ASTM Designation: D 3953-91.

PART 2

13 - 16 AUGUST 1996

ATTENDEES

Bradley J. Haas
Mechanical Engineer
DSN 585-8336
815-273-8336

Director
U.S. Army Defense Ammunition Center
3700 Army Depot Road
ATTN: SIOAC-DEV
Savanna, IL 61074-9639

Ejike J. Ajalla
Mechanical Engineer
DSN 585-8434
815-273-8434

Director
U.S. Army Defense Ammunition Center
3700 Army Depot Road
ATTN: SIOAC-DEV
Savanna, IL 61074-9639

PART 3

TEST PROCEDURES

The salt-fog test procedures were performed IAW ASTM Designation: B 117-90. The tension test procedures are summarized from ASTM Designation: D 3953-91. These publications identify steps that each sample must go through in order to meet the specifications. For a detailed description of tests conducted see part 8.

A. SALT-FOG TESTING. This portion of the testing was performed at Rock Island Arsenal (RIA) IAW ASTM Designation: B 117-90. A total of 17 specimens of 1-1/4-inch galvanized steel strapping with a Delta, style III, painted seal and 17 control specimens of 1-1/4-inch galvanized steel strapping were exposed to salt-fog aging. Specimens of each type were removed after specified time intervals.

B. TENSION TEST. This test was performed IAW ASTM Designation: D 3953-91. A 12- to 16-inch specimen was placed between the jaws of the tension/compression machine with the jaws separated 8-12 inches. The distance between the jaws was increased at a speed not greater than 2 inches per minute, elongating the strap until it broke. The maximum force applied was measured.

PART 4

TEST EQUIPMENT

A. SAMPLE NO. 1.

- | | |
|---------------------|----------------------------------------|
| 1. Strap: | ACME Packaging Corporation, Galvanized |
| 2. Seal: | Delta Corporation, Style III, Painted |
| 3. No. of Specimen: | 17 |
| 4. Length: | 17 inches |
| 5. Width: | 1-1/4 inches |
| 6. Thickness: | 0.035 inches |

B. SAMPLE NO. 2.

- | | |
|---------------------|----------------------------------------|
| 1. Strap: | ACME Packaging Corporation, Galvanized |
| 2. Seal: | None |
| 3. No. of Specimen: | 17 |
| 4. Length: | 17 inches |
| 5. Width: | 1-1/4 inches |
| 6. Thickness: | 0.035 inches |

C. SAMPLE NO. 3.

- | | |
|---------------------|--------------------------------------------|
| 1. Strap: | ACME Packaging Corporation, Galvanized |
| 2. Seal: | Stanley Corporation, Style III, Galvanized |
| 3. No. of Specimen: | 5 |
| 4. Length: | 17 inches |
| 5. Width: | 1-1/4 inches |
| 6. Thickness: | 0.035 inches |

D. SAMPLE NO. 4.

- | | |
|---------------------|----------------------------------------|
| 1. Strap: | ACME Packaging Corporation, Galvanized |
| 2. Seal: | None |
| 3. No. of Specimen: | 5 |
| 4. Length: | 17 inches |
| 5. Width: | 1-1/4 inches |
| 6. Thickness: | 0.035 inches |

E. SAMPLE NO. 5.

- | | |
|---------------------|----------------------------------------------|
| 1. Strap: | ACME Packaging Corporation, Galvanized 34HOC |
| 2. Seal: | Signode Corporation, Painted |
| 3. No. of Specimen: | 5 |
| 4. Length: | 14 inches |
| 5. Width: | 3/4 inch |
| 6. Thickness: | 0.035 inches |

F. SAMPLE NO. 6.

- | | |
|---------------------|----------------------------------------------|
| 1. Strap: | ACME Packaging Corporation, Galvanized 34HOC |
| 2. Seal: | None |
| 3. No. of Specimen: | 5 |
| 4. Length: | 14 inches |
| 5. Width: | 3/4 inch |
| 6. Thickness: | 0.035 inches |

G. SAMPLE NO. 7.

- | | |
|---------------------|----------------------------------------------|
| 1. Strap: | ACME Packaging Corporation, Galvanized 34AHP |
| 2. Seal: | Signode Corporation, Painted Auto |
| 3. No. of Specimen: | 5 |
| 4. Length: | 14 inches |
| 5. Width: | 3/4 inch |
| 6. Thickness: | 0.035 inches |

H. SAMPLE NO. 8.

- | | |
|---------------------|----------------------------------------------|
| 1. Strap: | ACME Packaging Corporation, Galvanized 34AHP |
| 2. Seal: | None |
| 3. No. of Specimen: | 5 |
| 4. Length: | 14 inches |
| 5. Width: | 3/4 inch |
| 6. Thickness: | 0.035 inches |

I. TENSION-COMPRESSION MACHINE.

- | | |
|--------------------|------------------------------------|
| 1. Manufacturer: | Instron, Model 1125 |
| 2. Capacity: | 20,000 pounds |
| 3. Extension Rate: | 2.0 inches per minute |
| 4. Data Analysis: | Automated Computer Testing Program |

PART 5

TEST RESULTS

A. SALT-FOG TESTING. This portion of testing was performed at Rock Island Arsenal (RIA) IAW ASTM Designation: B 117-90. Twelve specimens of Acme steel strapping/Delta, style III, painted seal combination and 12 samples of ACME Packaging Corporation galvanized steel strapping were placed in the salt-fog chamber. Five samples of each specimen were not exposed to salt-fog aging. Three samples of each specimen were removed from the salt-fog chamber following 341; 732; 1,140; and 1,497 hours of aging.

B. TENSION TEST. This portion of testing was performed IAW ASTM Designation: D 3953-91. The specimen was placed between the jaws of the tension/compression machine. The jaws were separated while the automated materials testing program recorded the applied force and displacement. The jaws continued to separate until the strap broke or the seal failed. Table 1 shows the average maximum force each strap was capable of withstanding after a specified amount of accelerated aging.

TABLE 1

Hours Accel. Aging	Average Maximum Force (Pounds)		Seal Efficiency % of Min. Break. Strength
	<u>Delta Paint Seal</u>	<u>Acme Galv Strap/No Seal</u>	
0	5532 +/- 273	6829 +/- 384	116.5
341	5780 +/- 69	7016 +/- 32	121.7
732	5692 +/- 156	6660 +/- 137	119.8
1141	5730 +/- 102	6930 +/- 23	120.6
1497	5659 +/- 88	7000 +/- 54	119.1

According to ASTM Designation: D 3953-91, the minimum breaking strength for 1-1/4-inch strapping is 4,750 pounds. For strapping fastened by a double crimped seal, the minimum joint efficiency is 75 percent of the minimum breaking strength of the applicable strapping size. The ACME Packaging Corporation galvanized strap and the Delta, style III, painted seal met these criteria. Additionally, accelerated aging has a minimal effect on ACME Packaging Corporation strapping and Delta, style III, painted seals.

According to ASTM Designation: D 3953-91, the minimum breaking strength for 3/4-inch strapping is 2,850 pounds. For strapping fastened by a double crimped seal, the minimum joint efficiency is 75 percent of the minimum breaking strength of the applicable strapping size. Table 2 displays the results of additional samples exposed to 0 hours of accelerated aging. Each of these samples met the requirements of ASTM Designation: D 3953-91. Periodic tension tests were performed on these samples by Mason & Hanger - Silas Mason Co., Inc. at Iowa Army Ammunition Plant (IAAAP). The results of these tests are located in part 8. The breaking strength values reported by Mason & Hanger were consistently lower than the values of this test.

TABLE 2

Strap	Seal	Maximum Load (Pounds)		(Percent)
		Strap/Seal	Strap/No Seal	Joint Efficiency
1-1/4" Acme Galv	Stanley Galv	5541+/-465	6588+/-539	116.6
3/4" Galv 34HOC	Signode Paint	3036+/-110	4014+/-30	106.5
3/4" Galv 34AHP	Signode Paint	3094+/-371	3986+/-20	108.6

In 1994, testing was performed on seals supplied by Signode Corporation. One group of test samples utilized a grade III galvanized clip. A second group of test samples employed a painted seal. Table 3 contains a comparison of the results of the two sets of tests. All specimens included in this table utilized ACME Packaging Corporation Corporation 1-1/4-inch steel strapping.

TABLE 3

(Hours) Accelerated Aging	Average Maximum Load (Pounds)		
	Signode Painted Seal	Signode Grade III Galvanized Seal	Delta Style III Painted Seal
0	5053+/-122	4767+/-350	5532+/-273
341	5080+/-115	4914+/-438	5780+/- 69
732	5076+/- 35	4786+/-274	5692+/-156
1140	4735+/-126	4645+/-332	5730+/-102
1428	5013+/-155	5032+/-162	5659+/- 88

At each time interval, the average load required to cause failure of the Delta, style III, painted seal is greater than the load required to cause failure of the Signode Painted Seal and the Signode Grade III Galvanized Seal.

PART 6

PHOTOGRAPHS



U.S. ARMY DEFENSE AMMUNITION CENTER AND SCHOOL -
SAVANNA, IL

AO317-SCN97-14-247. This photo shows the ACME Packaging Corporation galvanized steel strapping with Delta Corporation painted seal following testing. The sample on the right was not exposed to accelerated aging. The sample on the left was exposed to 1,428 hours of salt-fog accelerated aging.

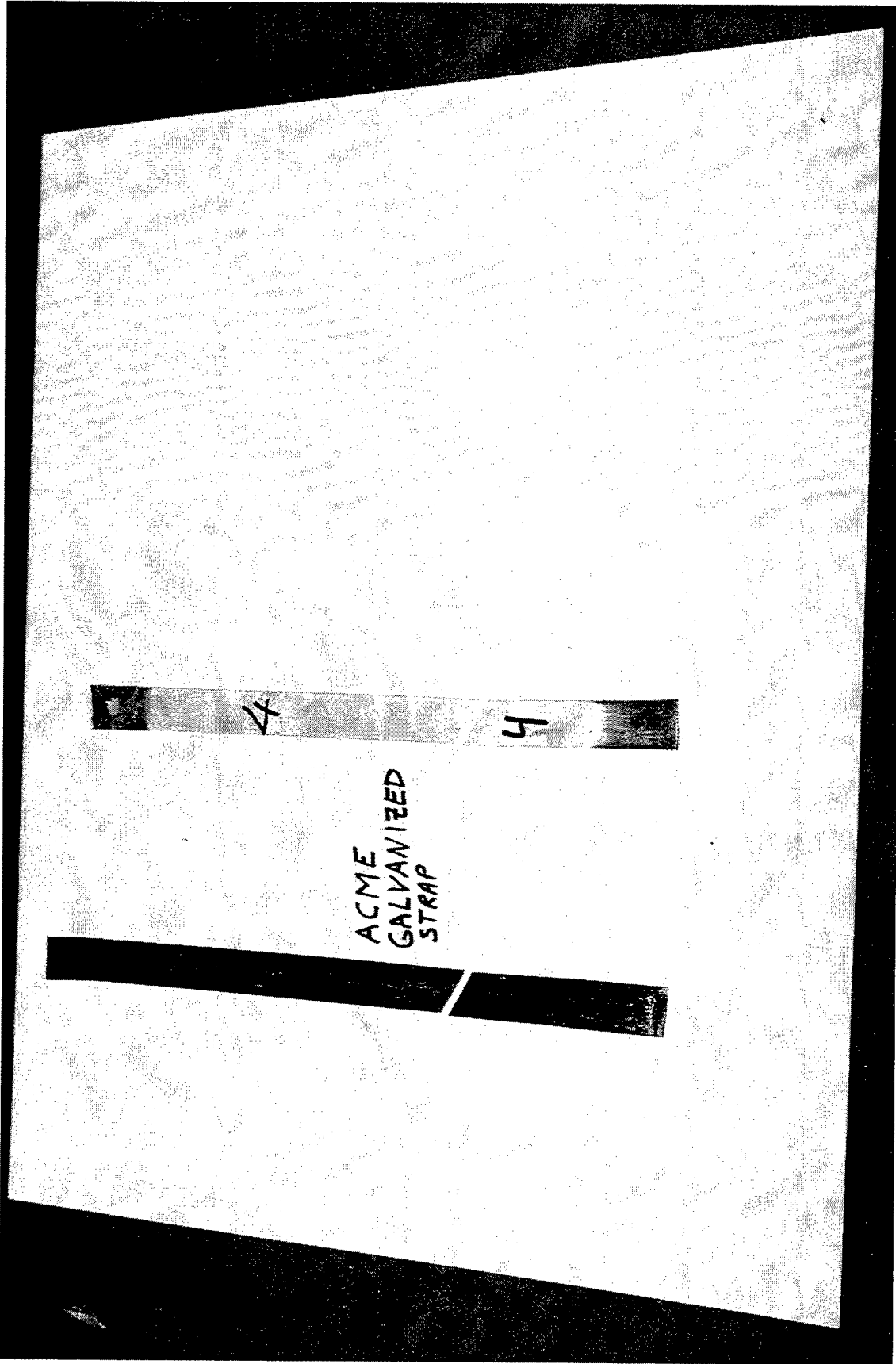

	U.S. ARMY DEFENSE AMMUNITION CENTER AND SCHOOL - SAVANNA, IL	
AO317-SCN97-14-248. This photo shows ACME Packaging Corporation galvanized steel strapping with no seal following testing. The sample on the right was not exposed to accelerated aging. The sample on the left was exposed to 1,428 hours of salt-fog accelerated aging.		

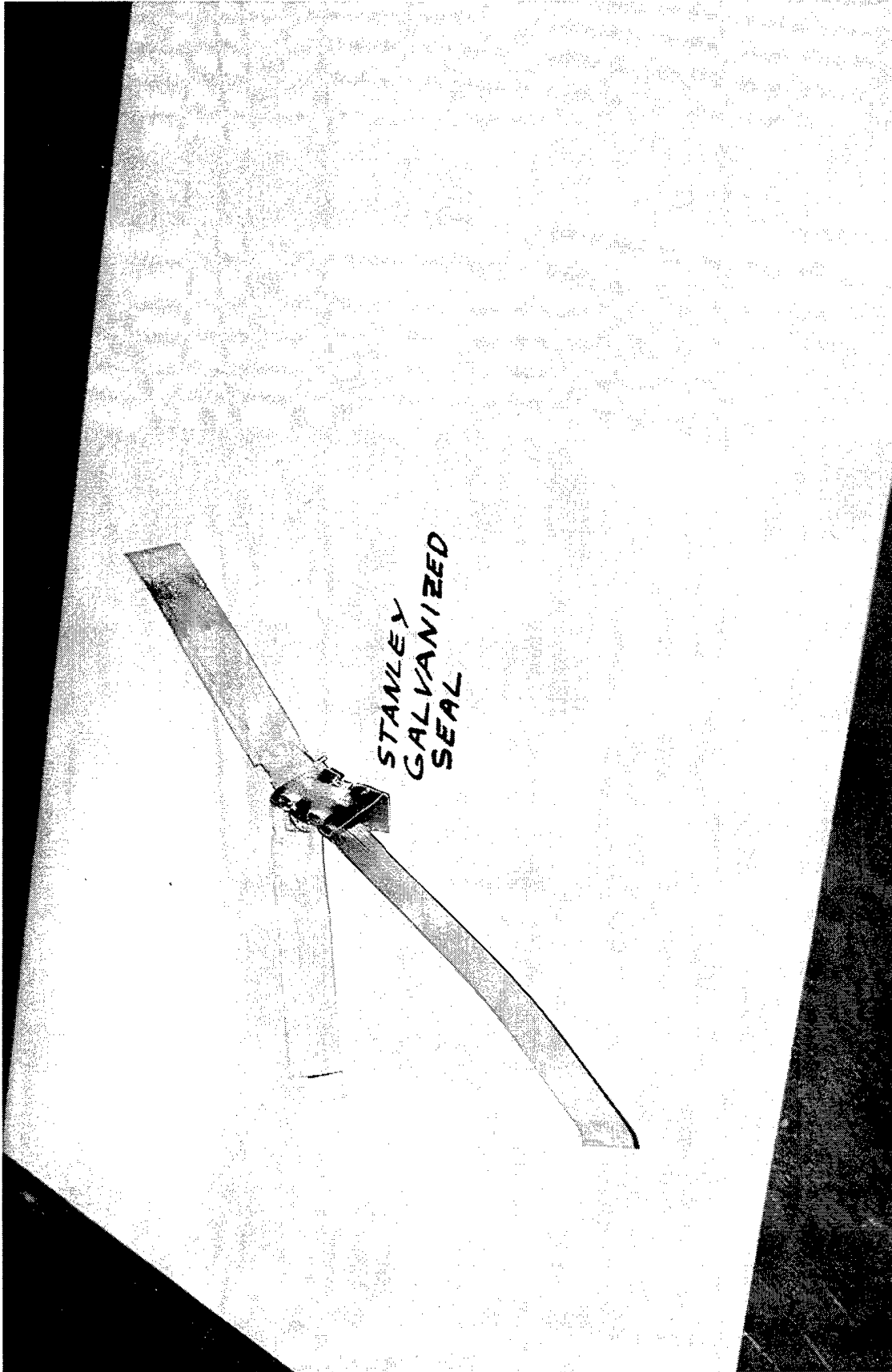

	U.S. ARMY DEFENSE AMMUNITION CENTER AND SCHOOL - SAVANNA, IL	
AO317-SCN97-14-244. This photo shows ACME Packaging Corporation galvanized steel strapping with Stanley Corporation galvanized seal following testing. This sample was not exposed to salt-fog accelerated aging.		

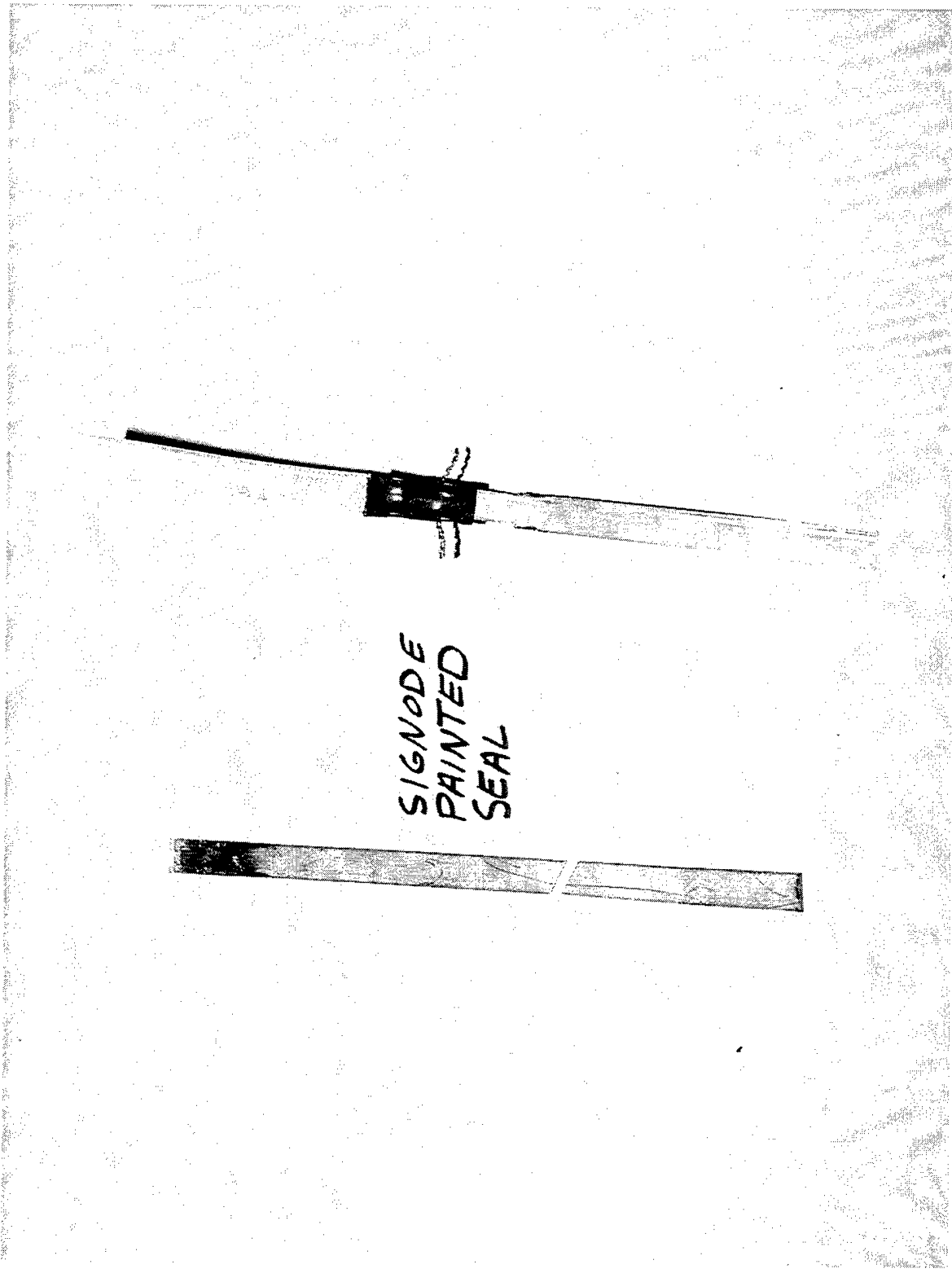

	U.S. ARMY DEFENSE AMMUNITION CENTER AND SCHOOL - SAVANNA, IL	
AO317-SCN97-14-245. The sample on the right is ACME Packaging Corporation galvanized strapping with a Signode Corporation painted seal. The sample on the left is a control sample of ACME Packaging Corporation galvanized strapping with no seal. Neither sample was exposed to salt-fog accelerated aging.		

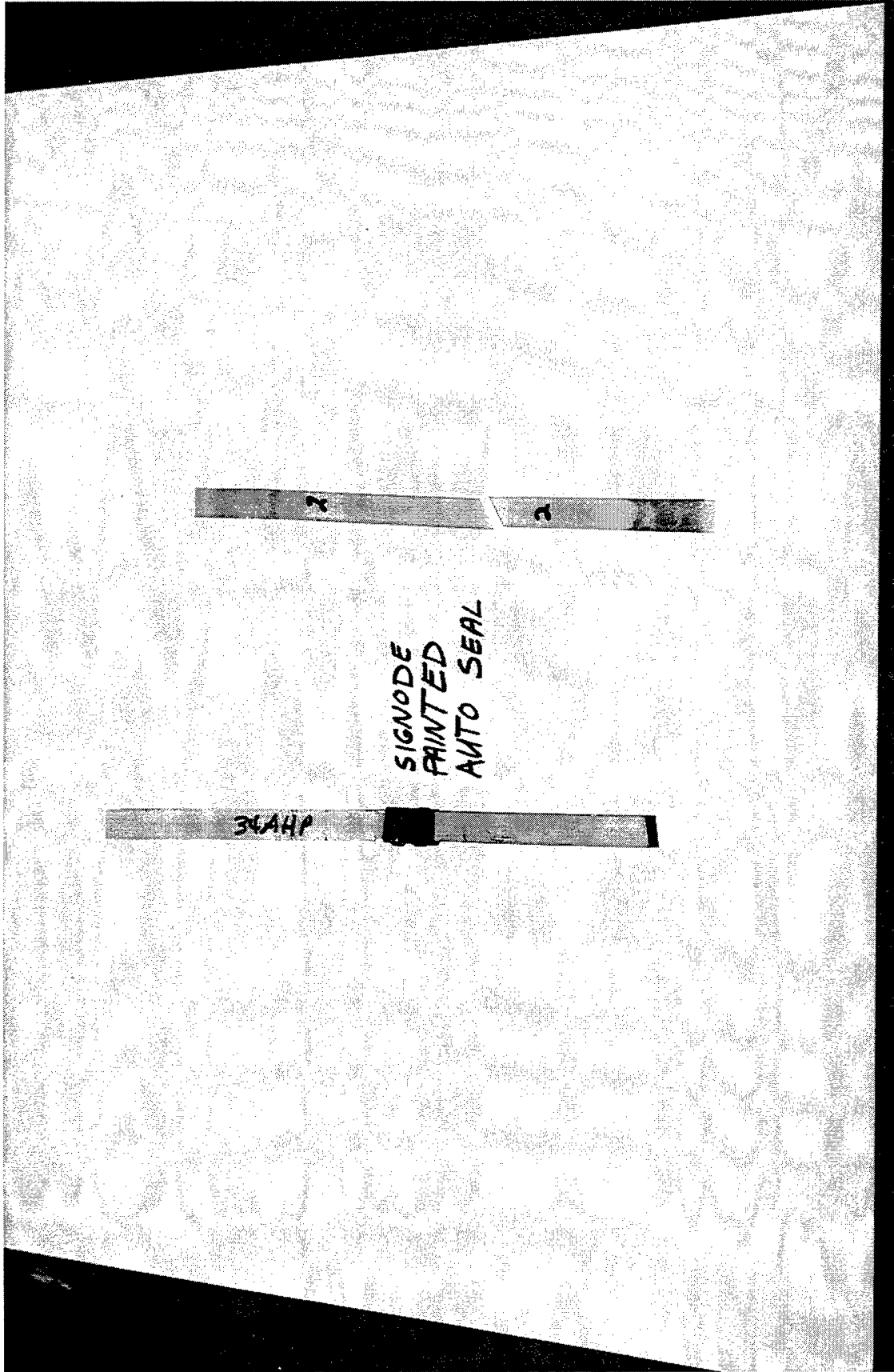

U.S. ARMY DEFENSE AMMUNITION CENTER AND SCHOOL -
SAVANNA, IL

AO317-SCN97-14-246. The sample on the left is ACME Packaging Corporation galvanized strapping with a Signode Corporation painted auto seal. The sample on the right is a control sample of ACME Packaging Corporation galvanized strapping with no seal. Neither sample was exposed to salt-fog accelerated aging.

PART 7

GRAPHS

**DELTA PAINT SEAL
WITH 1-1/4-INCH
ACME PACKAGING CORPORATION
GALVANIZED STRAP**

USADACS
SIOAC_DEV
Savanna, IL

General Tensile Test - US Customary Units

Test type: Tensile Instron Corporation
Series IX Automated Materials Testing System 6.03
Operator name: HAAS Test Date: 14 Aug 1996

Sample Identification: delta0 Sample Type: ASTM
Interface Type: Data Systems Adapter

Machine Parameters of test:
Sample Rate (pts/sec): 18.206 Humidity (%): 50
Crosshead Speed (in/min): 2.0000 Temperature (deg. F): 73
Full Scale Load Range (lbs): 20000.0000

Dimensions:
Sample
Width (in) 1.2500
Thickness (in) .03500
Spec gauge len (in) 2.0000
Grip distance: (in) 12.000

Out of 5 specimens, 0 excluded.
Sample comments: Galvanized banding/Galvanized Delta Seal0 hours aging

Specimen Number	Load at Peak (lbs)	Stress at Peak (psi)	Displcment at Peak (in)	% Strain at Peak (%)	Load at Break (lbs)	Stress at Break (psi)	Displcment at Break (in)	% Strain at Break (%)	Load at 0.2% Yield (lbs)
1	5693.	130100.	2.6290	131.50	2017.	46110.	2.8950	144.70	2469.
2	5633.	128800.	1.0450	52.27	2023.	46240.	1.2980	64.90	3148.
3	5623.	128500.	1.7650	88.25	2800.	64010.	2.0010	100.10	2534.
4	5666.	129500.	1.5860	79.28	1958.	44740.	1.7960	89.80	2936.
5	5046.	115300.	.7305	36.53	3312.	75690.	.8678	43.39	2648.
Mean:	5532.	126500.	1.5510	77.56	2422.	55360.	1.7720	88.58	2747.
Standard Deviation:	273.	6244.	.7311	36.56	607.	13870.	.7674	38.37	287.

Specimen Number	Stress at 0.2% Yield (psi)	Displcment at 0.2% Yield (in)	% Strain at 0.2% Yield (%)	Young's Modulus (ksi)	Energy at Yield (lbs-in)	Energy at Break (lbs-in)
1	56430.	.1410	7.049	1959.	87.06	12620.
2	71960.	.1190	5.950	1985.	129.20	5908.
3	57920.	.1153	5.767	1936.	89.00	8717.
4	67120.	.1135	5.676	2055.	112.40	8097.
5	60530.	.1025	5.126	1961.	94.32	3307.

Mean:	62790.	.1183	5.914	1979.	102.40	7731.
Standard Deviation:	6561.	.0141	.705	46.	18.02	3462.

DELTA0 ALL

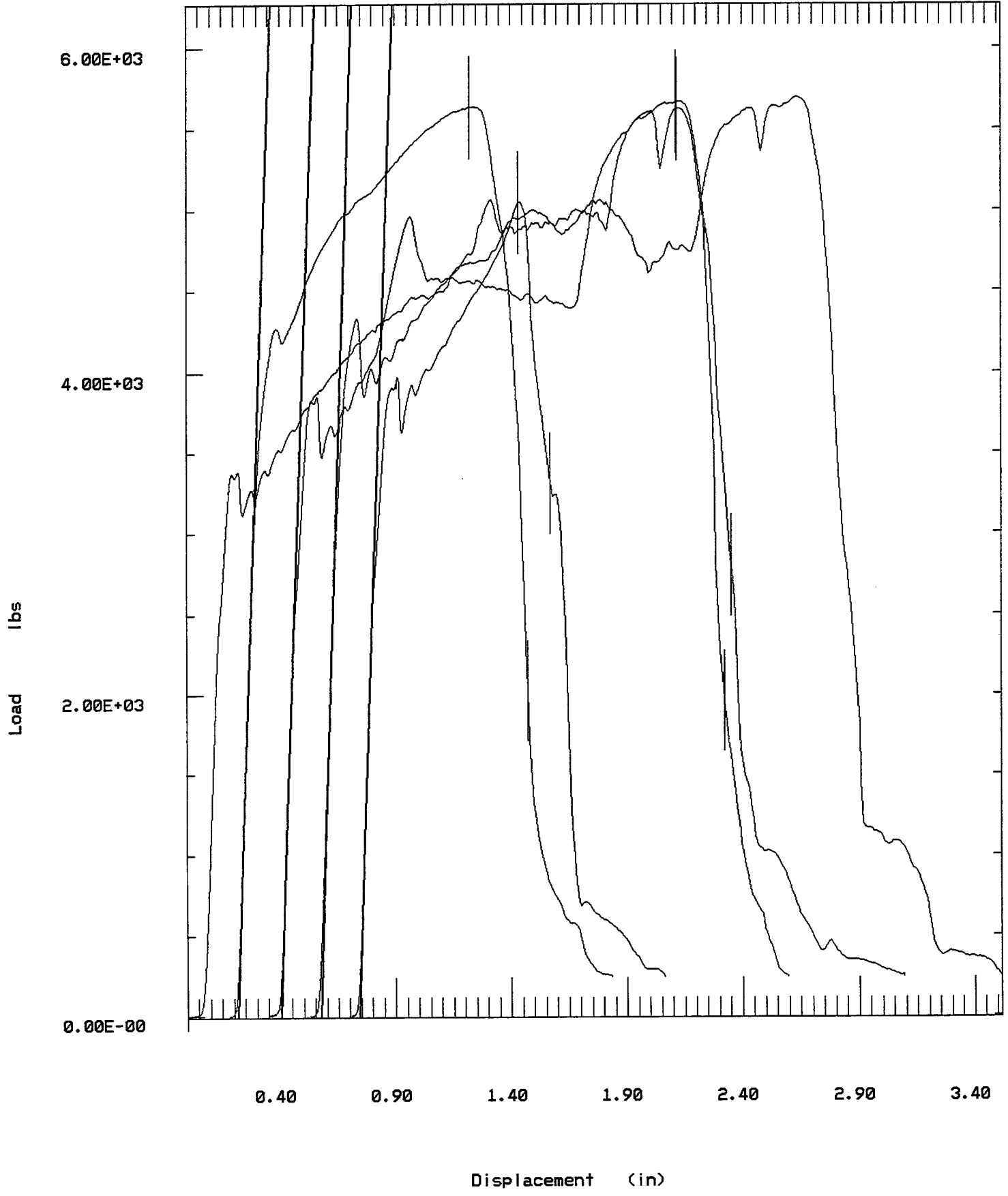

USADACS
SIOAC_DEV
Savanna, IL

General Tensile Test - US Customary Units

Test type: Tensile Instron Corporation
Operator name: HAAS Series IX Automated Materials Testing System 6.03
Test Date: 14 Aug 1996

Sample Identification: delta341 Sample Type: ASTM

Interface Type: Data Systems Adapter

Machine Parameters of test:

Sample Rate (pts/sec): 18.206 Humidity (%): 50
Crosshead Speed (in/min): 2.0000 Temperature (deg. F): 73
Full Scale Load Range (lbs): 20000.0000

Dimensions:

Sample
Width (in) 1.2500
Thickness (in) .03500
Spec gauge len (in) 2.0000
Grip distance: (in) 12.000

Out of 3 specimens, 0 excluded.

Sample comments: Galvanized Strap\Galvanized Delta Seal 341 Hours Aging

Specimen Number	Load at Peak (lbs)	Stress at Peak (psi)	Displcment at Peak (in)	% Strain at Peak (%)	Load at Break (lbs)	Stress at Break (psi)	Displcment at Break (in)	% Strain at Break (%)	Load at 0.2% Yield (lbs)
1	5721.	130800.	1.3490	67.47	2132.	48720.	1.6000	80.01	3051.
2	5856.	133900.	.9319	46.60	2322.	53070.	.9520	47.60	1702.
3	5764.	131700.	1.1240	56.21	2333.	53320.	1.7560	87.79	2980.
Mean:	5780.	132100.	1.1350	56.76	2262.	51710.	1.4360	71.80	2577.
Standard Deviation:	69.	1587.	.2089	10.45	113.	2586.	.4263	21.31	759.

Specimen Number	Stress at 0.2% Yield (psi)	Displcment at 0.2% Yield (in)	% Strain at 0.2% Yield (%)	Young's Modulus (ksi)	Energy at Yield (lbs-in)	Energy at Break (lbs-in)
1	69730.	.1337	6.683	1911.	124.80	6597.
2	38900.	.0732	3.662	2009.	41.52	3750.
3	68110.	.1190	5.950	2001.	116.60	7057.
Mean:	58910.	.1086	5.432	1974.	94.33	5801.
Standard Deviation:	17350.	.0315	1.576	55.	45.92	1791.

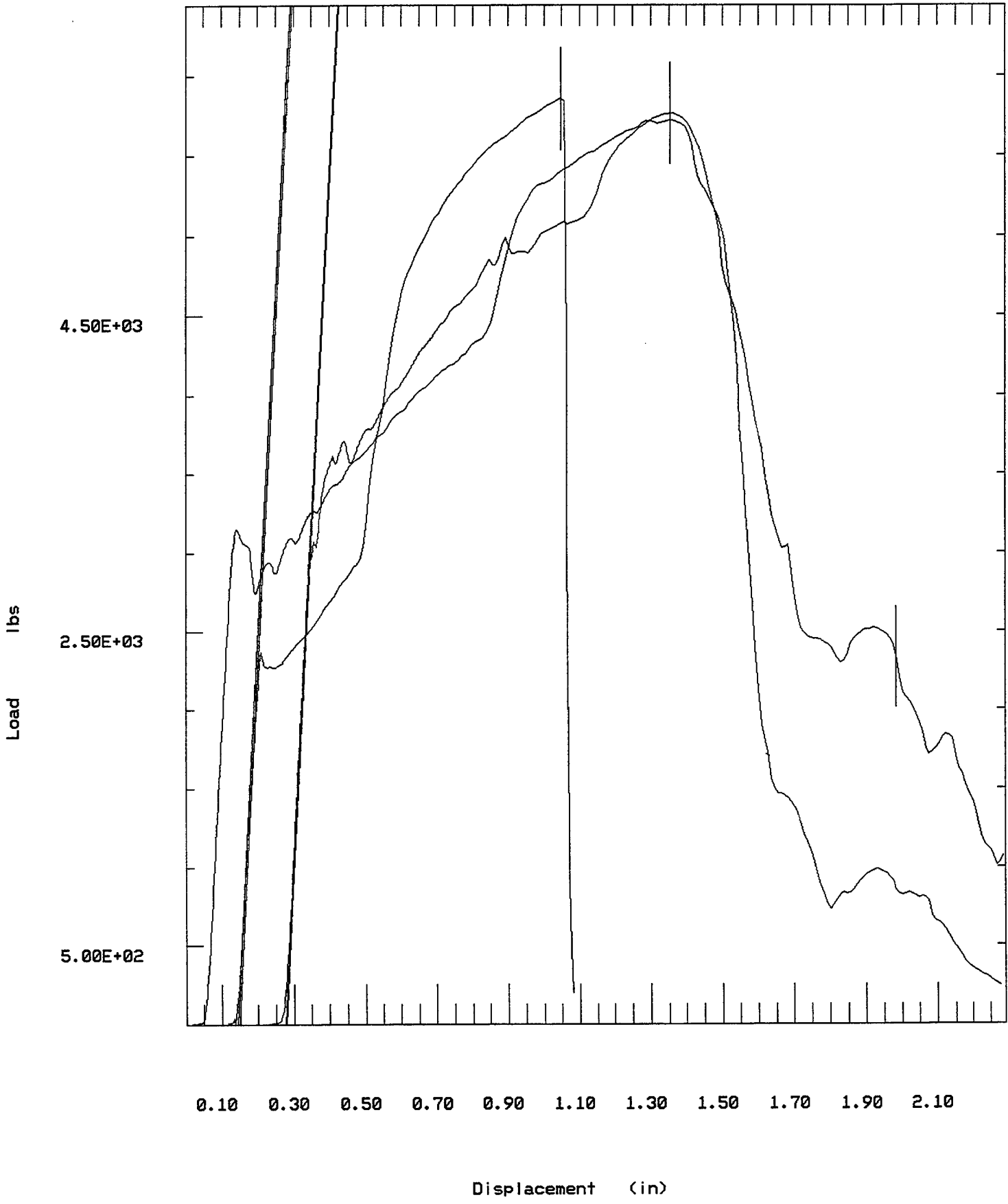

USADACS
SIOAC_DEV
Savanna, IL

General Tensile Test - US Customary Units

Test type: Tensile

Instron Corporation

Series IX Automated Materials Testing System 6.03

Operator name: HAAS

Test Date: 14 Aug 1996

Sample Identification: delta732

Sample Type: ASTM

Interface Type: Data Systems Adapter

Machine Parameters of test:

Sample Rate (pts/sec): 18.206

Humidity (%): 50

Crosshead Speed (in/min): 2.0000

Temperature (deg. F): 73

Full Scale Load Range (lbs): 20000.0000

Dimensions:

	Sample
Width (in)	1.2500
Thickness (in)	.03500
Spec gauge len (in)	2.0000
Grip distance: (in)	12.000

Out of 3 specimens, 0 excluded.

Sample comments: Galvanized Strap\Galvanized Delta Seal 732 Hours Aging

Specimen Number	Load at Peak (lbs)	Stress at Peak (psi)	Displcment at Peak (in)	% Strain at Peak (%)	Load at Break (lbs)	Stress at Break (psi)	Displcment at Break (in)	% Strain at Break (%)	Load at 0.2% Yield (lbs)
1	5872.	134200.	.7232	36.16	2065.	47210.	.7433	37.17	3028.
2	5594.	127900.	.4504	22.52	2228.	50930.	1.0450	52.27	2495.
3	5611.	128200.	1.2520	62.62	1886.	43100.	1.7740	88.71	2179.
Mean:	5692.	130100.	.8086	40.43	2060.	47080.	1.1880	59.38	2567.
Standard Deviation:	156.	3557.	.4077	20.39	171.	3917.	.5299	26.49	429.

Specimen Number	Stress at 0.2% Yield (psi)	Displcment at 0.2% Yield (in)	% Strain at 0.2% Yield (%)	Young's Modulus (ksi)	Energy at Yield (lbs-in)	Energy at Break (lbs-in)
1	69210.	.1227	6.133	1527.	144.70	3315.
2	57020.	.1263	6.316	1794.	91.25	3820.
3	49820.	.1776	8.880	1526.	79.48	6850.
Mean:	58680.	.1422	7.110	1616.	105.20	4662.
Standard Deviation:	9800.	.0307	1.535	154.	34.79	1912.

DELTA732

ALL

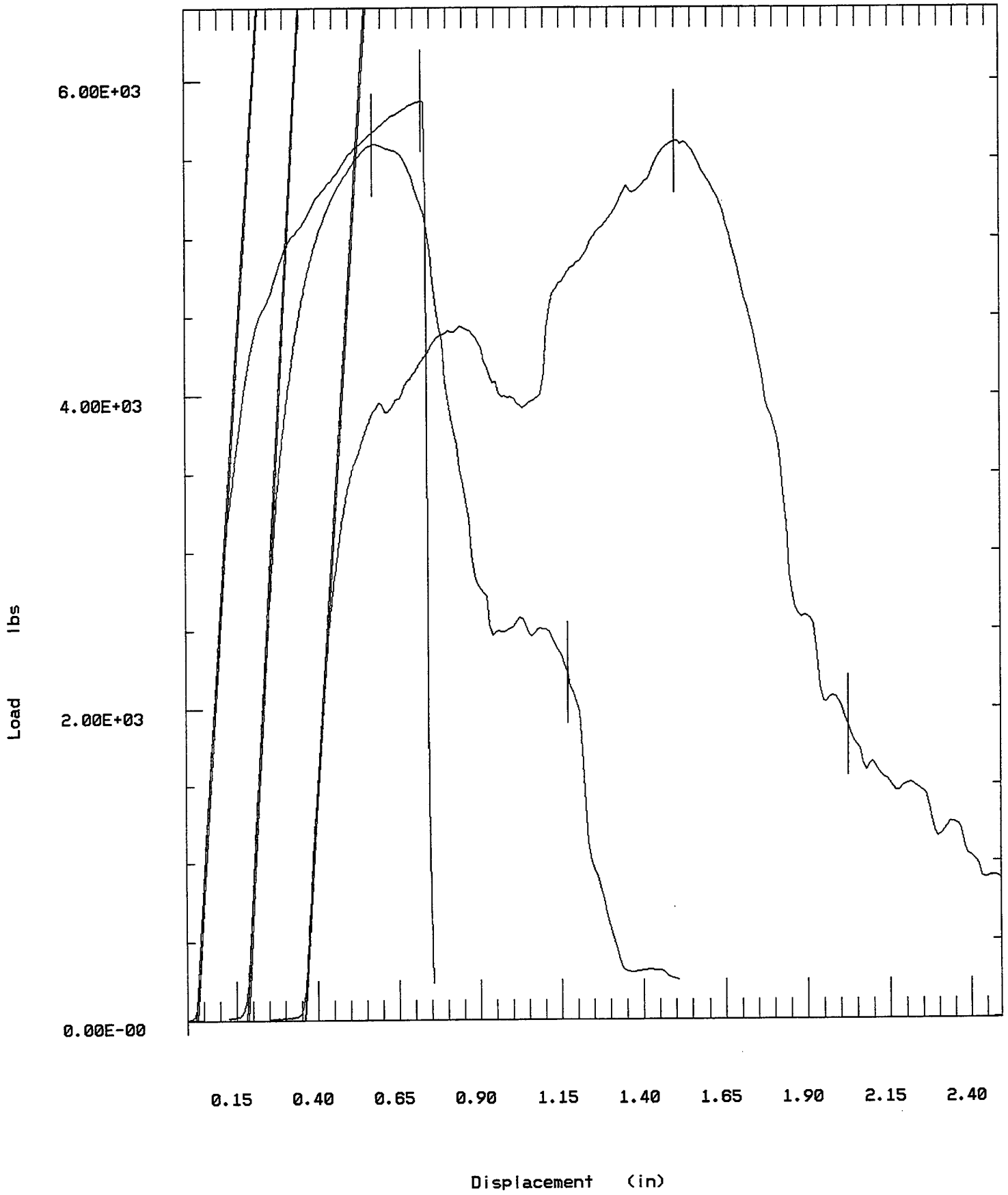

USADACS
SIOAC_DEV
Savanna, IL

General Tensile Test - US Customary Units

Test type: Tensile	Instron Corporation
Operator name: HAAS	Series IX Automated Materials Testing System 6.03
	Test Date: 14 Aug 1996
Sample Identification: delt1140	Sample Type: ASTM
Interface Type: Data Systems Adapter	
Machine Parameters of test:	
Sample Rate (pts/sec): 18.206	Humidity (%): 50
Crosshead Speed (in/min): 2.0000	Temperature (deg. F): 73
Full Scale Load Range (lbs): 20000.0000	

Dimensions:

	Sample
Width (in)	1.2500
Thickness (in)	.03500
Spec gauge len (in)	2.0000
Grip distance: (in)	12.000

Out of 3 specimens, 0 excluded.

Sample comments: Galvanized Strap\Galvanized Delta Seal 1140 Hours Aging

Specimen Number	Load at Peak (lbs)	Stress at Peak (psi)	Displcment at Peak (in)	% Strain at Peak (%)	Load at Break (lbs)	Stress at Break (psi)	Displcment at Break (in)	% Strain at Break (%)	Load at 0.2% Yield (lbs)
1	5688.	130000.	.5401	27.01	2539.	58040.	.7799	39.00	2501.
2	5655.	129300.	1.1660	58.31	2186.	49970.	1.5230	76.16	1686.
3	5846.	133600.	.6573	32.86	2246.	51330.	.9063	45.31	2904.
Mean:	5730.	131000.	.7879	39.39	2324.	53110.	1.0700	53.49	2364.
Standard Deviation:	102.	2326.	.3329	16.64	189.	4324.	.3977	19.89	621.

Specimen Number	Stress at 0.2% Yield (psi)	Displcment at 0.2% Yield (in)	% Strain at 0.2% Yield (%)	Young's Modulus (ksi)	Energy at Yield (lbs-in)	Energy at Break (lbs-in)
1	57170.	.1062	5.309	1738.	91.00	3218.
2	38530.	.1172	5.859	1622.	48.03	5715.
3	66370.	.1099	5.493	1647.	124.80	4004.
Mean:	54030.	.1111	5.554	1669.	87.93	4312.
Standard Deviation:	14190.	.0056	.280	61.	38.46	1277.

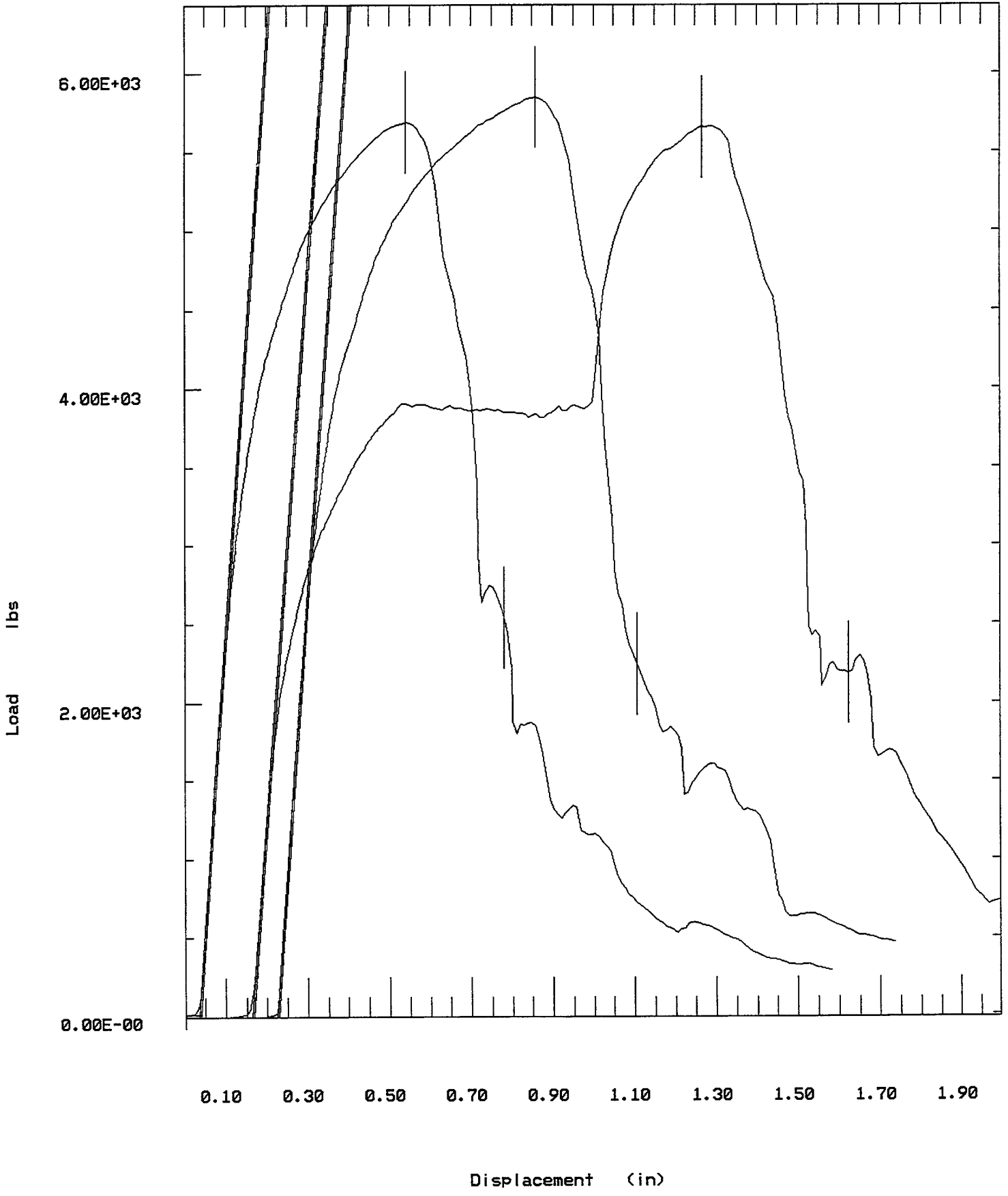

USADACS
SIOAC_DEV
Savanna, IL

General Tensile Test - US Customary Units

Test type: Tensile

Instron Corporation
Series IX Automated Materials Testing System 6.03
Test Date: 14 Aug 1996

Operator name: HAAS

Sample Identification: delt1497
Interface Type: Data Systems Adapter
Machine Parameters of test:

Sample Type: ASTM

Sample Rate (pts/sec): 18.206
Crosshead Speed (in/min): 2.0000
Full Scale Load Range (lbs): 20000.0000

Humidity (%): 50
Temperature (deg. F): 73

Dimensions:

	Sample
Width (in)	1.2500
Thickness (in)	.03500
Spec gauge len (in)	2.0000
Grip distance: (in)	12.000

Out of 3 specimens, 0 excluded.

Sample comments: Galvanized Strap\Galvanized Delta Seal 1497 Hours Aging

Specimen Number	Load at Peak (lbs)	Stress at Peak (psi)	Displcment at Peak (in)	% Strain at Peak (%)	Load at Break (lbs)	Stress at Break (psi)	Displcment at Break (in)	% Strain at Break (%)	Load at 0.2% Yield (lbs)
1	5563.	127200.	.5786	28.93	1860.	42520.	.9081	45.41	294.2
2	5737.	131100.	.5493	27.46	2170.	49600.	.5639	28.20	3421.0
3	5678.	129800.	.6316	31.58	1926.	44010.	1.0050	50.26	3095.0
Mean:	5659.	129400.	.5865	29.32	1985.	45380.	.8257	41.29	2270.0
Standard Deviation:	88.	2021.	.0418	2.09	163.	3735.	.2319	11.59	1719.0

Specimen Number	Stress at 0.2% Yield (psi)	Displcment at 0.2% Yield (in)	% Strain at 0.2% Yield (%)	Young's Modulus (ksi)	Energy at Yield (lbs-in)	Energy at Break (lbs-in)
1	6724.	.0348	1.739	1437.	2.054	3605.
2	78190.	.1446	7.232	1532.	193.000	2315.
3	70730.	.1282	6.408	1530.	159.300	4106.
Mean:	51880.	.1025	5.126	1500.	118.100	3342.
Standard Deviation:	39290.	.0592	2.962	54.	101.900	924.

DELT1497 ALL

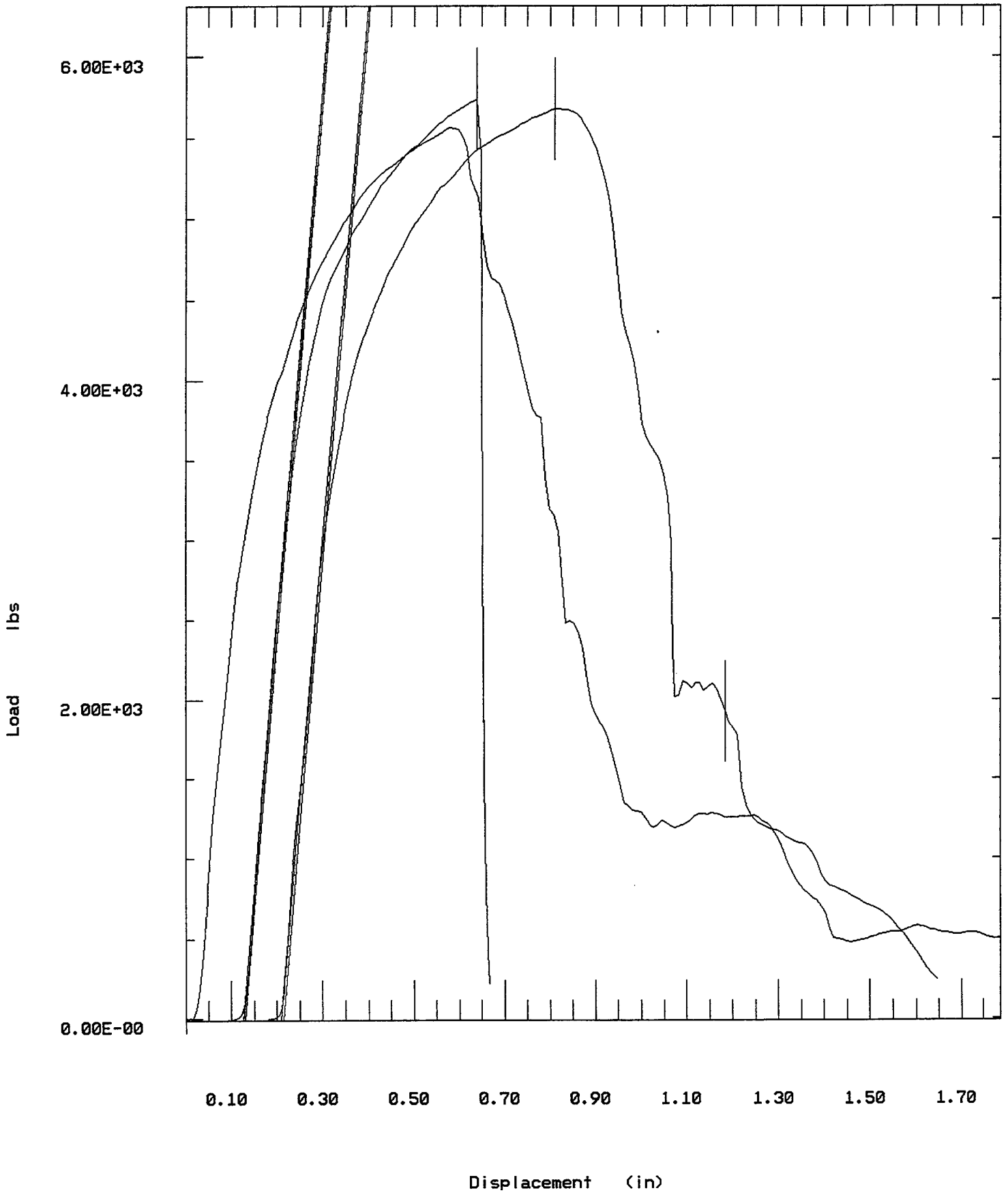

1-1/4-INCH
ACME PACKAGING CORPORATION
GALVANIZED STRAP

USADACS
SIOAC_DEV
Savanna, IL

General Tensile Test - US Customary Units

Test type: Tensile	Instron Corporation
	Series IX Automated Materials Testing System 6.03
Operator name: HAAS	Test Date: 15 Aug 1996
Sample Identification: age0	Sample Type: ASTM
Interface Type: Data Systems Adapter	
Machine Parameters of test:	
Sample Rate (pts/sec): 18.206	Humidity (%): 50
Crosshead Speed (in/min): 2.0000	Temperature (deg. F): 73
Full Scale Load Range (lbs): 20000.0000	

Dimensions:

	Sample
Width (in)	1.2500
Thickness (in)	.03500
Spec gauge len (in)	2.0000
Grip distance: (in)	12.000

Out of 5 specimens, 2 excluded.
Sample comments: Galvanized Strap, 0 Hours Aging Samples 3 and 5 Slipped

Specimen Number	Load at Peak (lbs)	Stress at Peak (psi)	Displcment at Peak (in)	% Strain at Peak (%)	Load at Break (lbs)	Stress at Break (psi)	Displcment at Break (in)	% Strain at Break (%)	Load at 0.2% Yield (lbs)
1	6399.	146300.	.8935	44.67	2539.	58030.	1.011	50.53	3060.
2	7136.	163100.	2.4370	121.80	2652.	60610.	2.761	138.00	3829.
Excluded	6668.	152400.	2.0320	101.60	2179.	49800.	3.413	170.60	3227.
4	6953.	158900.	2.4640	123.20	2856.	65280.	2.801	140.10	3152.
Excluded	6700.	153100.	2.6790	133.90	2254.	51520.	3.704	185.20	2851.
Mean:	6829.	156100.	1.9320	96.58	2682.	61310.	2.191	109.50	3347.
Standard Deviation:	384.	8766.	.8991	44.96	161.	3675.	1.022	51.12	420.

Specimen Number	Stress at 0.2% Yield (psi)	Displcment at 0.2% Yield (in)	% Strain at 0.2% Yield (%)	Young's Modulus (ksi)	Energy at Yield (lbs-in)	Energy at Break (lbs-in)
1	69950.	.1520	7.598	2211.	110.80	5225.
2	87530.	.1062	5.309	2515.	148.80	16380.
Excluded	73760.	.1227	6.133	2666.	103.70	15540.
4	72040.	.1538	7.690	2656.	98.43	16050.
Excluded	65160.	.0824	4.119	2536.	85.43	18690.

Mean:	76510.	.1373	6.866	2461.	119.30	12550.
Standard Deviation:	9600.	.0270	1.349	227.	26.24	6348.

AGE0

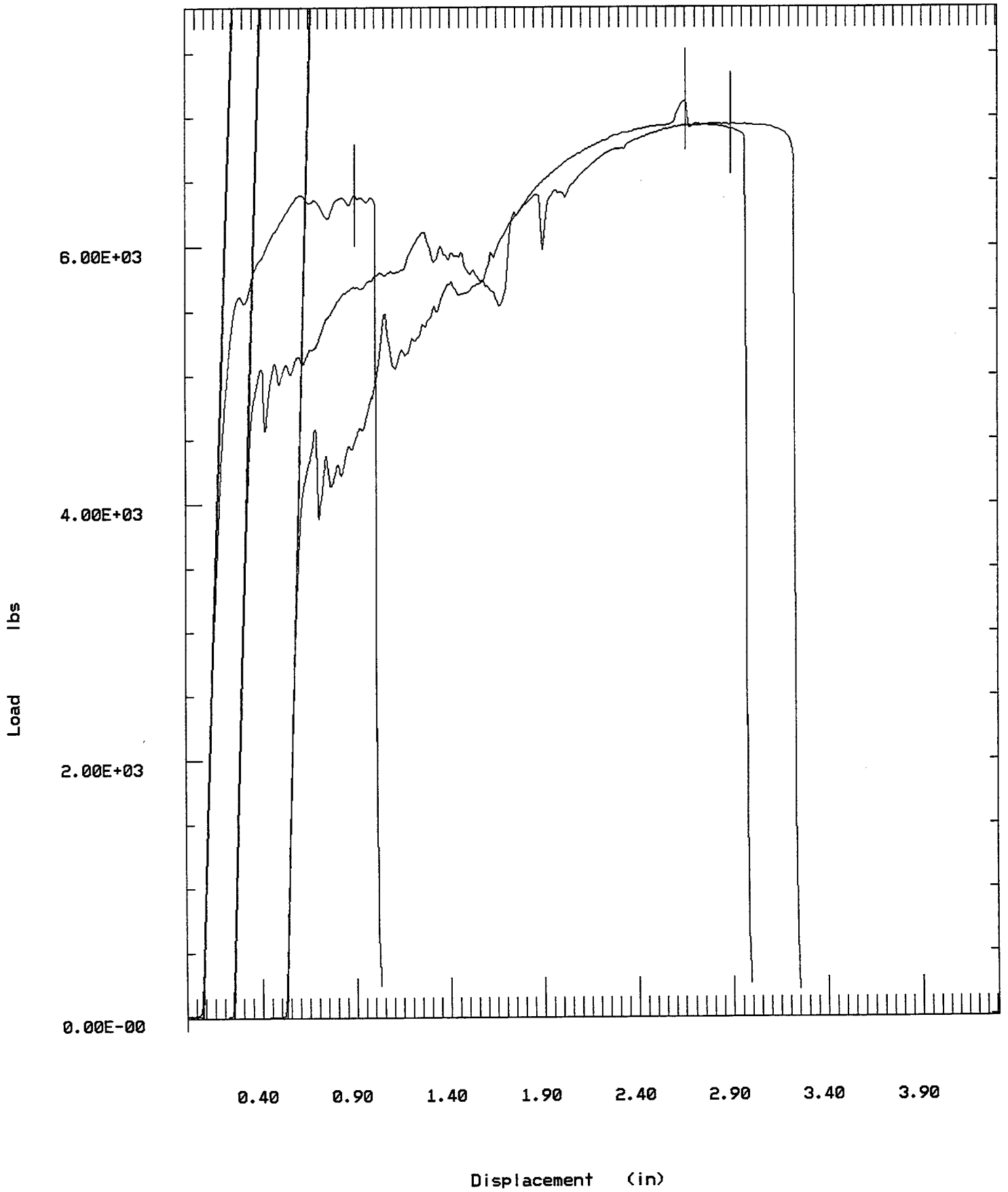

USADACS
SIOAC_DEV
Savanna, IL

General Tensile Test - US Customary Units

Test type: Tensile

Instron Corporation

Series IX Automated Materials Testing System 6.03

Operator name: HAAS

Test Date: 15 Aug 1996

Sample Identification: age341

Sample Type: ASTM

Interface Type: Data Systems Adapter

Machine Parameters of test:

Sample Rate (pts/sec): 18.206

Humidity (%): 50

Crosshead Speed (in/min): 2.0000

Temperature (deg. F): 73

Full Scale Load Range (lbs): 20000.0000

Dimensions:

	Sample
Width (in)	1.2500
Thickness (in)	.03500
Spec gauge len (in)	2.0000
Grip distance: (in)	12.000

Out of 2 specimens, 1 excluded.

Sample comments: Galvanized Strap, 341 Hours Aging

Sample #1 was malfunction

Specimen Number	Load at Peak (lbs)	Stress at Peak (psi)	Displcment at Peak (in)	% Strain at Peak (%)	Load at Break (lbs)	Stress at Break (psi)	Displcment at Break (in)	% Strain at Break (%)	Load at 0.2% Yield (lbs)
Excluded	4.838	110.6	.0128	.6408	4.838	110.6	.0128	.6408	-.5382
2	6979.000	159500.0	1.6400	82.0200	3044.000	69570.0	1.9610	98.0400	2511.0000
Mean:	6979.000	159500.0	1.6400	82.0200	3044.000	69570.0	1.9610	98.0400	2511.0000

Standard

Deviation: -----

Specimen Number	Stress at 0.2% Yield (psi)	Displcment at 0.2% Yield (in)	% Strain at 0.2% Yield (%)	Young's Modulus (ksi)	Energy at Yield (lbs-in)	Energy at Break (lbs-in)
Excluded	-12.30	.0146	.7323	.0000	-.0015	-.001
2	57400.00	.0769	3.8450	2146.0000	74.3200	11690.000
Mean:	57400.00	.0769	3.8450	2146.0000	74.3200	11690.0000

Standard

Deviation: -----

AGE341

SPEC # 02

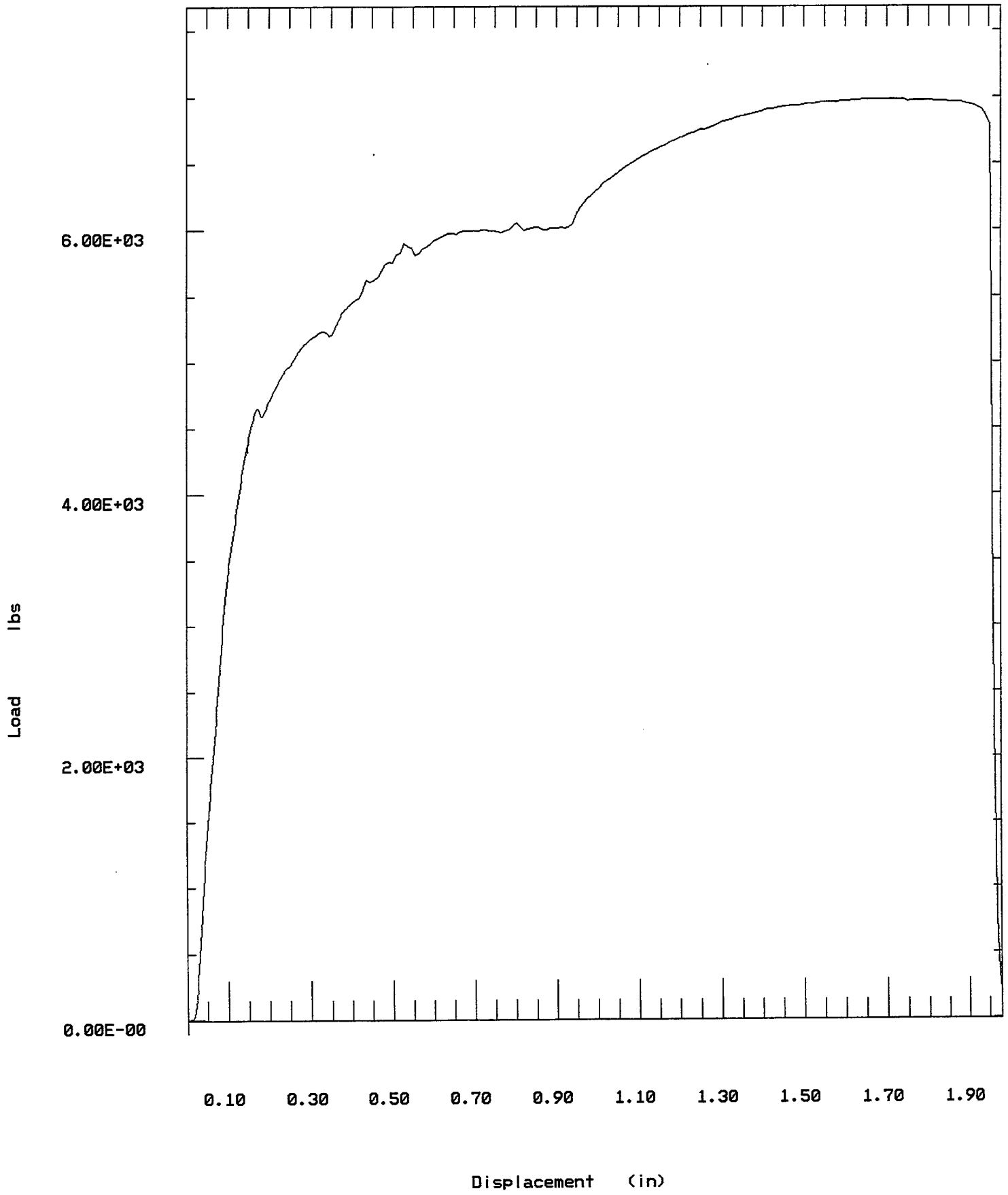

USADACS
SIOAC_DEV
Savanna, IL

General Tensile Test - US Customary Units

Test type: Tensile Instron Corporation
Series IX Automated Materials Testing System 6.03
 Operator name: HAAS Test Date: 15 Aug 1996
 Sample Identification: aged341 Sample Type: ASTM
 Interface Type: Data Systems Adapter
 Machine Parameters of test:
 Sample Rate (pts/sec): 18.206 Humidity (%): 50
 Crosshead Speed (in/min): 2.0000 Temperature (deg. F): 73
 Full Scale Load Range (lbs): 20000.0000

Dimensions:

	Sample
Width (in)	1.2500
Thickness (in)	.03500
Spec gauge len (in)	2.0000
Grip distance: (in)	12.000

Out of 2 specimens, 0 excluded.

Sample comments: Galvanized Strap, 341 Hours Aging

Specimen Number	Load at Peak (lbs)	Stress at Peak (psi)	Displcment at Peak (in)	% Strain at Peak (%)	Load at Break (lbs)	Stress at Break (psi)	Displcment at Break (in)	% Strain at Break (%)	Load at 0.2% Yield (lbs)
1	7032.	160700.	1.723	86.14	2414.	55170.	1.921	96.03	3231.
2	7037.	160900.	2.320	116.00	3032.	69300.	2.439	121.90	3005.
Mean:	7035.	160800.	2.021	101.10	2723.	62240.	2.180	109.00	3118.
Standard Deviation:	4.	87.	.422	21.10	437.	9993.	.366	18.32	160.

Specimen Number	Stress at 0.2% Yield (psi)	Displcment at 0.2% Yield (in)	% Strain at 0.2% Yield (%)	Young's Modulus (ksi)	Energy at Yield (lbs-in)	Energy at Break (lbs-in)
1	73850.	.0989	4.943	2106.	121.5	11600.
2	68690.	.0970	4.852	1787.	124.4	14120.
Mean:	71270.	.0980	4.898	1946.	122.9	12860.
Standard Deviation:	3650.	.0013	.065	225.	2.0	1784.

AGED341

ALL

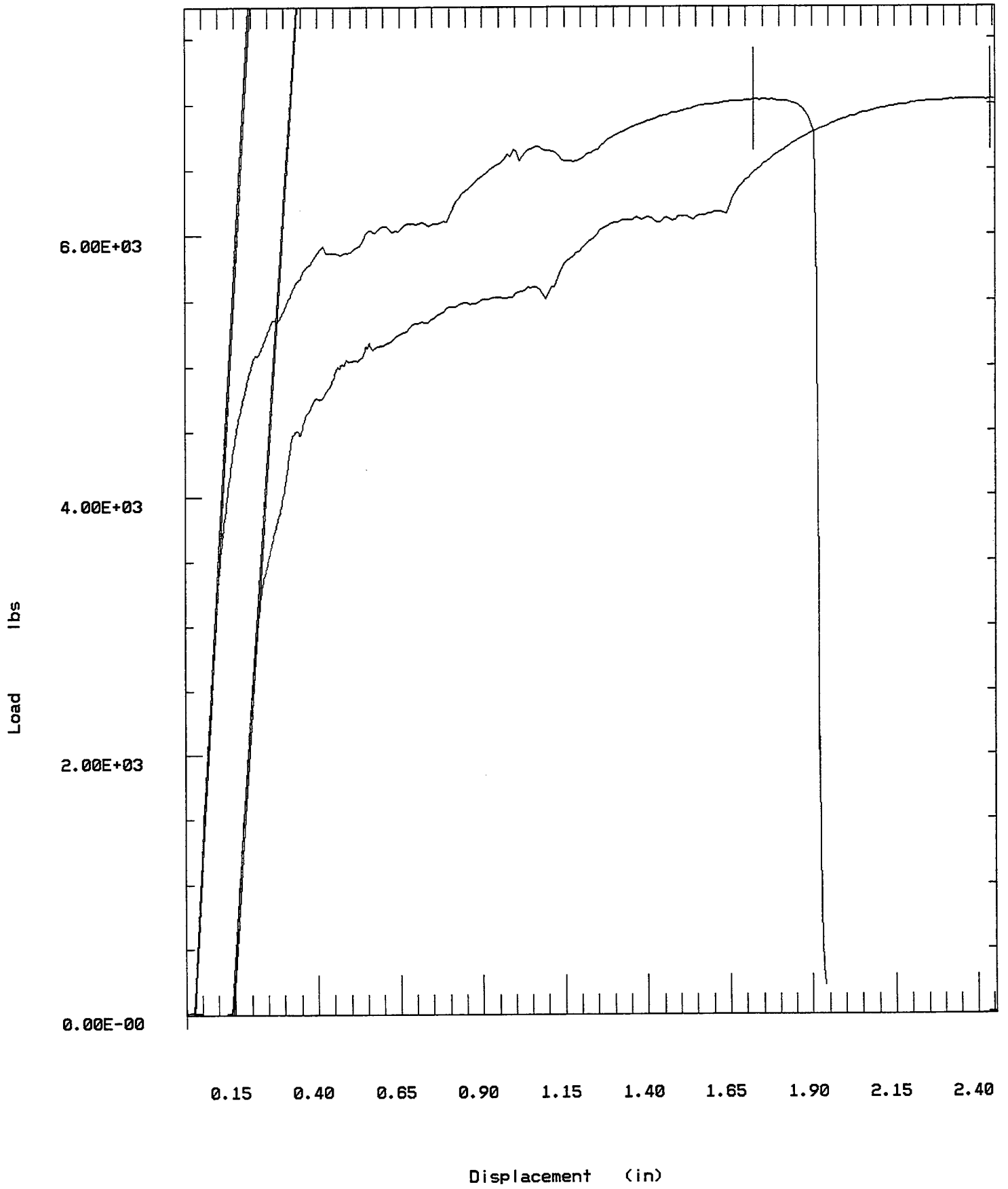

USADACS
SIOAC_DEV
Savanna, IL

General Tensile Test - US Customary Units

Test type: Tensile	Instron Corporation
Operator name: HAAS	Series IX Automated Materials Testing System 6.03
	Test Date: 15 Aug 1996
Sample Identification: aged732	Sample Type: ASTM
Interface Type: Data Systems Adapter	
Machine Parameters of test:	
Sample Rate (pts/sec): 18.206	Humidity (%): 50
Crosshead Speed (in/min): 2.0000	Temperature (deg. F): 73
Full Scale Load Range (lbs): 20000.0000	

Dimensions:

	Sample
Width (in)	1.2500
Thickness (in)	.03500
Spec gauge len (in)	2.0000
Grip distance: (in)	12.000

Out of 3 specimens, 1 excluded.

Sample comments: Galvanized Strap: 732 Hours Aging

Specimen Number	Load at Peak (lbs)	Stress at Peak (psi)	Displcment at Peak (in)	% Strain at Peak (%)	Load at Break (lbs)	Stress at Break (psi)	Displcment at Break (in)	% Strain at Break (%)	Load at 0.2% Yield (lbs)
1	6563.	150000.	2.063	103.20	6407.	146500.	2.265	113.2	2391.
Excluded	6536.	149400.	2.115	105.70	2321.	53060.	2.929	146.5	2176.
3	6757.	154400.	1.587	79.37	2461.	56250.	2.766	138.3	3493.
Mean:	6660.	152200.	1.825	91.27	4434.	101400.	2.516	125.8	2942.
Standard Deviation:	137.	3128.	.337	16.83	2790.	63780.	.355	17.7	779.

Specimen Number	Stress at 0.2% Yield (psi)	Displcment at 0.2% Yield (in)	% Strain at 0.2% Yield (%)	Young's Modulus (ksi)	Energy at Yield (lbs-in)	Energy at Break (lbs-in)
1	54650.	.0732	3.662	2392.	63.83	12340.
Excluded	49740.	.0769	3.845	2325.	55.10	12700.
3	79850.	.0934	4.669	2301.	131.70	15750.
Mean:	67250.	.0833	4.165	2346.	97.74	14040.
Standard Deviation:	17810.	.0142	.712	64.	47.97	2415.

AGED732

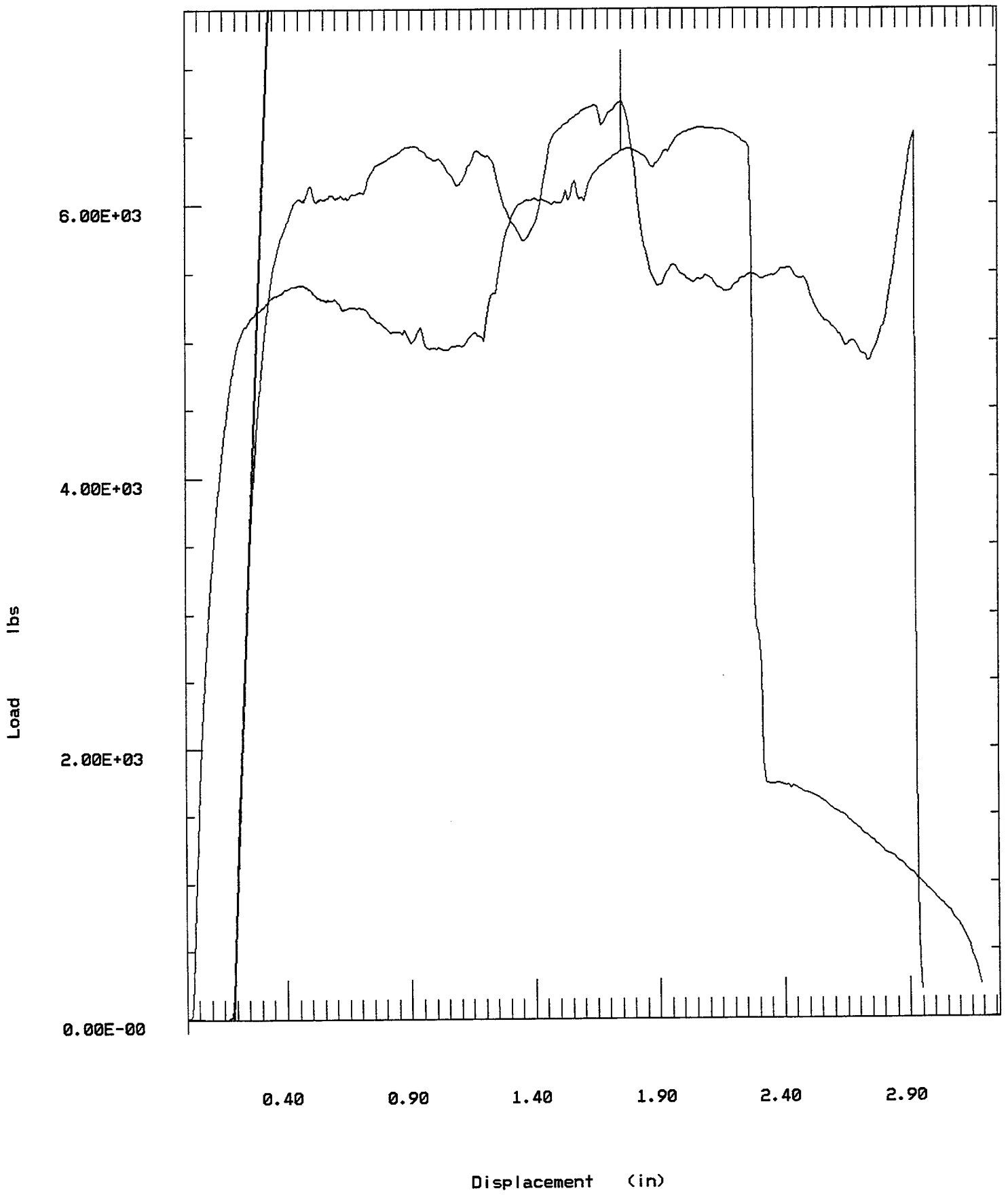

USADACS
SIOAC_DEV
Savanna, IL

General Tensile Test - US Customary Units

Test type: Tensile	Instron Corporation
	Series IX Automated Materials Testing System 6.03
Operator name: HAAS	Test Date: 15 Aug 1996
Sample Identification: aged	Sample Type: ASTM
Interface Type: Data Systems Adapter	
Machine Parameters of test:	
Sample Rate (pts/sec): 18.206	Humidity (%): 50
Crosshead Speed (in/min): 2.0000	Temperature (deg. F): 73
Full Scale Load Range (lbs): 20000.0000	

Dimensions:

	Sample
Width (in)	1.2500
Thickness (in)	.03500
Spec gauge len (in)	2.0000
Grip distance: (in)	12.000

Out of 3 specimens, 1 excluded.

Sample comments: Galvanized Banding: 1140 Hours Aging

Specimen Number	Load at Peak (lbs)	Stress at Peak (psi)	Displcment at Peak (in)	% Strain at Peak (%)	Load at Break (lbs)	Stress at Break (psi)	Displcment at Break (in)	% Strain at Break (%)	Load at 0.2% Yield (lbs)
Excluded	6306.	144100.	2.300	115.00	2403.	54930.	2.971	148.60	3156.
2	6914.	158000.	3.140	157.00	2801.	64020.	3.325	166.20	2769.
3	6946.	158800.	1.549	77.45	3005.	68690.	1.706	85.32	2403.
Mean:	6930.	158400.	2.344	117.20	2903.	66360.	2.516	125.80	2586.
Standard Deviation:	23.	521.	1.125	56.25	145.	3302.	1.144	57.22	259.

Specimen Number	Stress at 0.2% Yield (psi)	Displcment at 0.2% Yield (in)	% Strain at 0.2% Yield (%)	Young's Modulus (ksi)	Energy at Yield (lbs-in)	Energy at Break (lbs-in)
Excluded	72140.	.0897	4.486	2146.	115.20	15930.
2	63290.	.0806	4.028	2486.	81.89	19120.
3	54930.	.0732	3.662	2161.	67.63	10330.
Mean:	59110.	.0769	3.845	2323.	74.76	14720.
Standard Deviation:	5909.	.0052	.259	229.	10.08	6218.

AGED

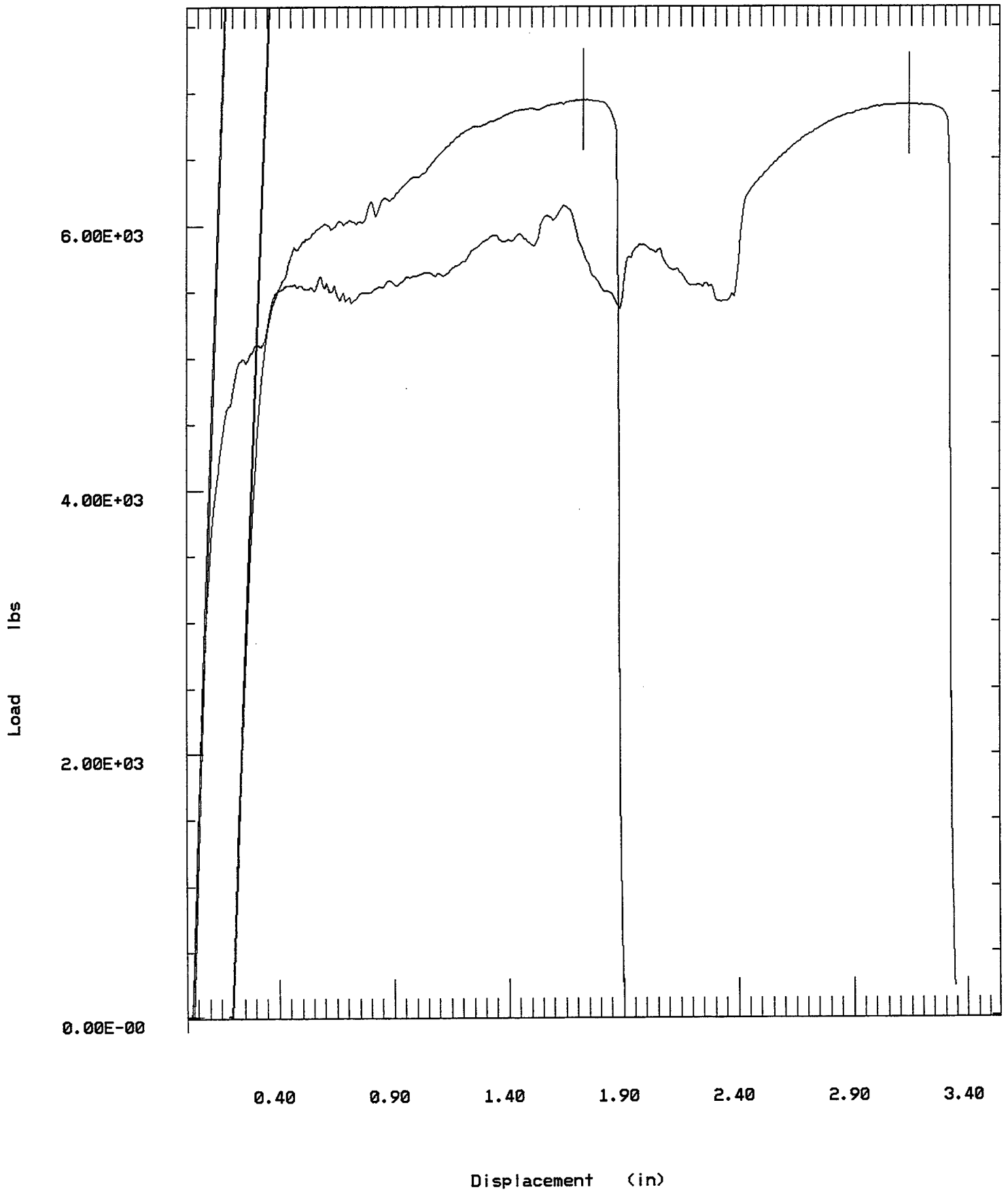

USADACS
SIOAC_DEV
Savanna, IL

General Tensile Test - US Customary Units

Test type: Tensile Instron Corporation
 Operator name: HAAS Series IX Automated Materials Testing System 6.03
 Test Date: 15 Aug 1996
 Sample Identification: aged1497 Sample Type: ASTM
 Interface Type: Data Systems Adapter
 Machine Parameters of test:
 Sample Rate (pts/sec): 18.206 Humidity (%): 50
 Crosshead Speed (in/min): 2.0000 Temperature (deg. F): 73
 Full Scale Load Range (lbs): 20000.0000

Dimensions:

	Sample
Width (in)	1.2500
Thickness (in)	.03500
Spec gauge len (in)	2.0000
Grip distance: (in)	12.000

Out of 3 specimens, 0 excluded.

Sample comments: Galvanized Strap: 1497 Hours Aging

Specimen Number	Load at Peak (lbs)	Stress at Peak (psi)	Displcment at Peak (in)	% Strain at Peak (%)	Load at Break (lbs)	Stress at Break (psi)	Displcment at Break (in)	% Strain at Break (%)	Load at 0.2% Yield (lbs)
1	6946.	158800.	2.076	103.80	2672.	61080.	2.259	113.00	2059.
2	7054.	161200.	1.223	61.15	2903.	66360.	1.613	80.65	2833.
3	7000.	160000.	1.399	69.94	2763.	63160.	1.791	89.53	2871.
Mean:	7000.	160000.	1.566	78.30	2780.	63530.	1.888	94.38	2588.
Standard Deviation:	54.	1229.	.450	22.53	116.	2661.	.334	16.69	458.

Specimen Number	Stress at 0.2% Yield (psi)	Displcment at 0.2% Yield (in)	% Strain at 0.2% Yield (%)	Young's Modulus (ksi)	Energy at Yield (lbs-in)	Energy at Break (lbs-in)
1	47070.	.0659	3.296	2245.	50.85	13770.
2	64760.	.0806	4.028	2694.	79.75	9696.
3	65620.	.0952	4.760	2017.	101.80	10600.
Mean:	59150.	.0806	4.028	2319.	77.47	11360.
Standard Deviation:	10470.	.0146	.732	344.	25.56	2137.

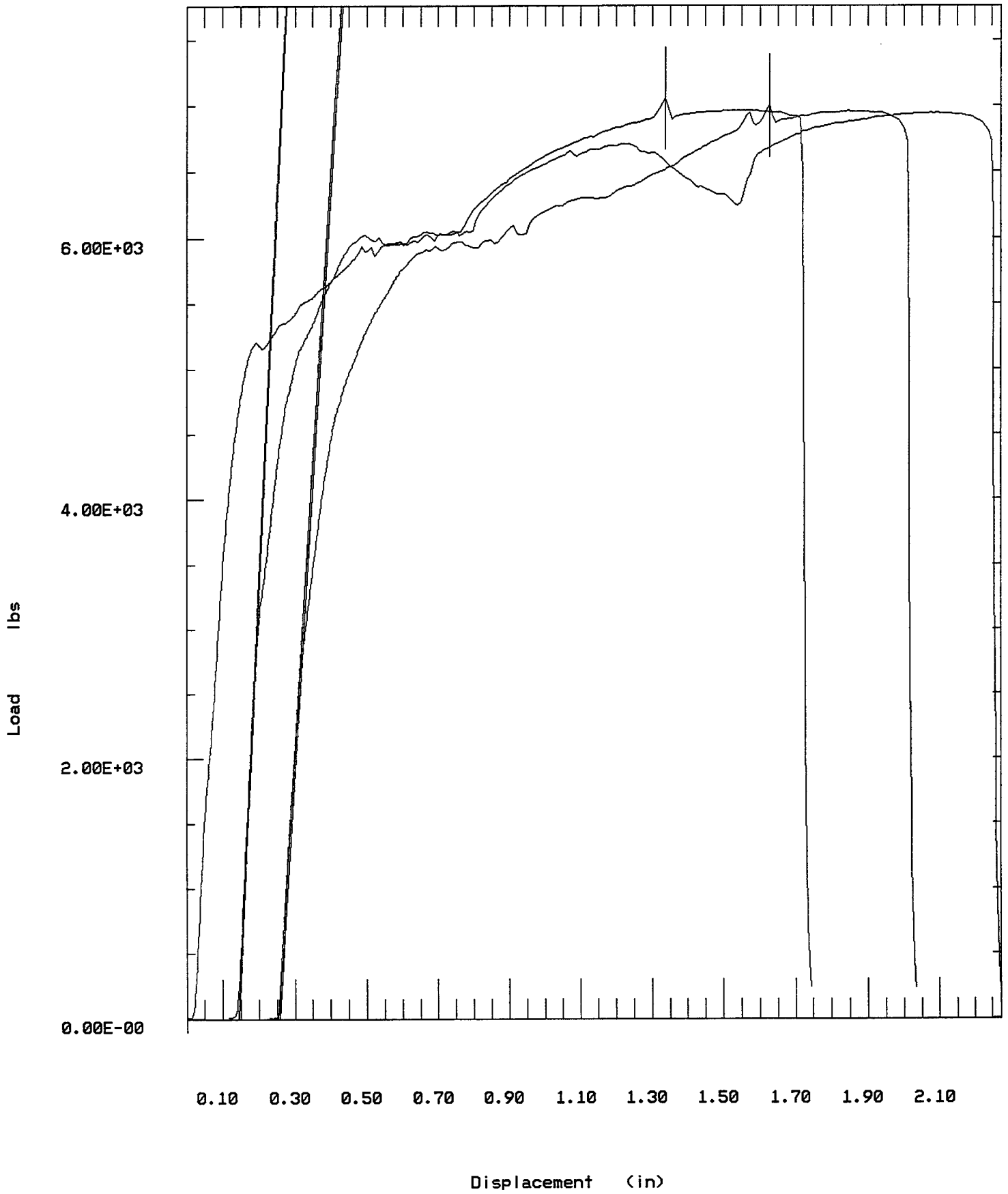

**STANLEY GALVANIZED
SEAL WITH 1-1/4-INCH
ACME PACKAGING CORPORATION
GALVANIZED STRAP**

USADACS
SIOAC_DEV
Savanna, IL

General Tensile Test - US Customary Units

Test type: Tensile Instron Corporation
Series IX Automated Materials Testing System 6.03
 Operator name: HAAS Test Date: 15 Aug 1996

Sample Identification: GALVO Sample Type: ASTM
 Interface Type: Data Systems Adapter

Machine Parameters of test:
 Sample Rate (pts/sec): 18.206 Humidity (%): 50
 Crosshead Speed (in/min): 2.0000 Temperature (deg. F): 73
 Full Scale Load Range (lbs): 20000.0000

Dimensions:
Sample
 Width (in) 1.2500
 Thickness (in) .03500
 Spec gauge len (in) 2.0000
 Grip distance: (in) 12.000

Out of 5 specimens, 0 excluded.

Sample comments: Galvanized Strap\Galvanized Seal 0 Hours Aging

Specimen Number	Load	Stress	Displcmnt	% Strain	Load	Stress	Displcmnt	% Strain	Load
	at Peak (lbs)	at Peak (psi)	at Peak (in)	at Peak (%)	at Break (lbs)	at Break (psi)	at Break (in)	at Break (%)	at 0.2% Yield (lbs)
1	5231.	119600.	1.3400	67.01	2183.	49890.	1.3710	68.57	2522.
2	4903.	112100.	.7214	36.07	1651.	37730.	.7378	36.89	2016.
3	4478.	102400.	.5273	26.36	1871.	42760.	.5676	28.38	2769.
4	5656.	129300.	2.3440	117.20	2108.	48170.	2.3560	117.80	2339.
5	5452.	124600.	.8147	40.74	2715.	62060.	1.1440	57.21	2575.
Mean:	5144.	117600.	1.1490	57.47	2105.	48120.	1.2350	61.77	2444.
Standard Deviation:	465.	10630.	.7322	36.61	400.	9140.	.7030	35.15	284.

Specimen Number	Stress	Displcmnt	% Strain	Young's	Energy	Energy
	at 0.2% Yield (psi)	at 0.2% Yield (in)	at 0.2% Yield (%)	Modulus (ksi)	at Yield (lbs-in)	at Break (lbs-in)
1	57630.	.0897	4.486	2015.	84.39	5796.
2	46080.	.1117	5.584	2048.	56.06	2354.
3	63290.	.1611	8.056	1937.	108.60	1735.
4	53460.	.1080	5.401	1866.	78.53	11110.
5	58860.	.1062	5.309	2183.	81.68	4932.

Mean:	55860.	.1153	5.767	2010.	81.84	5185.
Standard Deviation:	6494.	.0269	1.347	120.	18.68	3723.

GALVØ

ALL

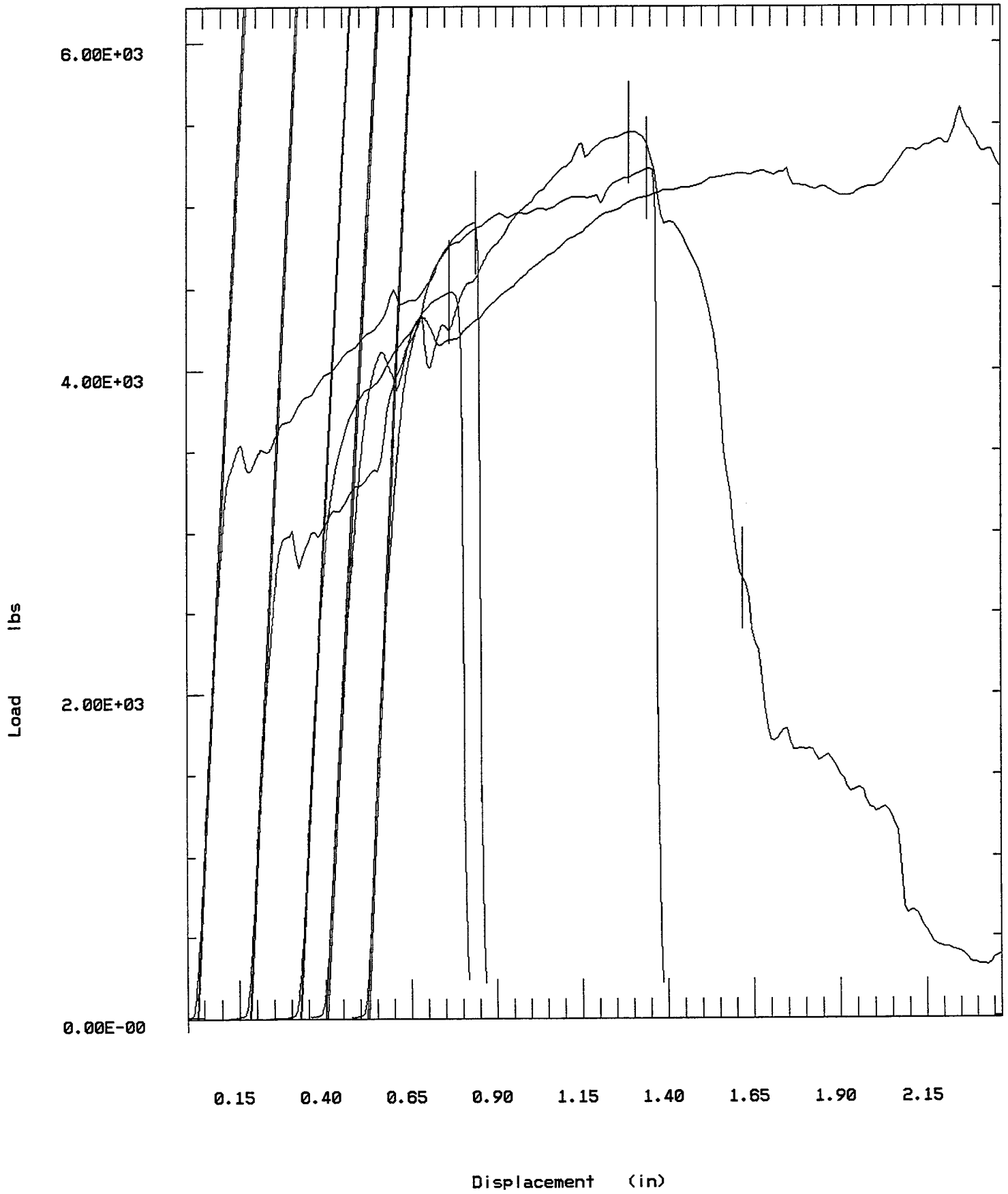

USADACS
SIOAC_DEV
Savanna, IL

General Tensile Test - US Customary Units

Test type: Tensile Instron Corporation
Series IX Automated Materials Testing System 6.03
 Operator name: HAAS Test Date: 15 Aug 1996
 Sample Identification: gstrap0 Sample Type: ASTM
 Interface Type: Data Systems Adapter
 Machine Parameters of test:
 Sample Rate (pts/sec): 18.206 Humidity (%): 50
 Crosshead Speed (in/min): 2.0000 Temperature (deg. F): 73
 Full Scale Load Range (lbs): 20000.0000

Dimensions:

	Sample
Width (in)	1.2500
Thickness (in)	.03500
Spec gauge len (in)	2.0000
Grip distance: (in)	12.000

Out of 5 specimens, 1 excluded.

Sample comments: Galvanized Strap\ 0 Hours Aging

Specimen Number	Load at Peak (lbs)	Stress at Peak (psi)	Displcment at Peak (in)	% Strain at Peak (%)	Load at Break (lbs)	Stress at Break (psi)	Displcment at Break (in)	% Strain at Break (%)	Load at 0.2% Yield (lbs)
1	6733.	153900.	2.096	104.80	2527.	57770.	2.137	106.80	3312.
2	5789.	132300.	1.767	88.34	3702.	84610.	1.889	94.47	2066.
3	6907.	157900.	1.853	92.64	2722.	62220.	1.906	95.30	2409.
Excluded	6753.	154400.	2.693	134.70	2266.	51790.	3.083	154.20	2656.
5	6922.	158200.	3.072	153.60	2861.	65390.	3.250	162.50	3061.

Mean: 6588. 150600. 2.197 109.90 2953. 67500. 2.295 114.80 2712.

Standard

Deviation: 539. 12330. .600 29.99 518. 11830. .646 32.31 575.

Specimen Number	Stress at 0.2% Yield (psi)	Displcment at 0.2% Yield (in)	% Strain at 0.2% Yield (%)	Young's Modulus (ksi)	Energy at Yield (lbs-in)	Energy at Break (lbs-in)
1	75700.	.1153	5.767	2418.	117.00	11450.
2	47220.	.6408	32.040	1485.	82.95	6255.
3	55070.	.0861	4.303	2794.	58.02	10650.
Excluded	60700.	.0732	3.662	2881.	67.24	16440.
5	69960.	.0824	4.119	2839.	89.17	17620.

Mean:	61990.	.2311	11.560	2384.	86.77	11490.
Standard						
Deviation:	13130.	.2735	13.680	628.	24.21	4678.

GSTRAP0

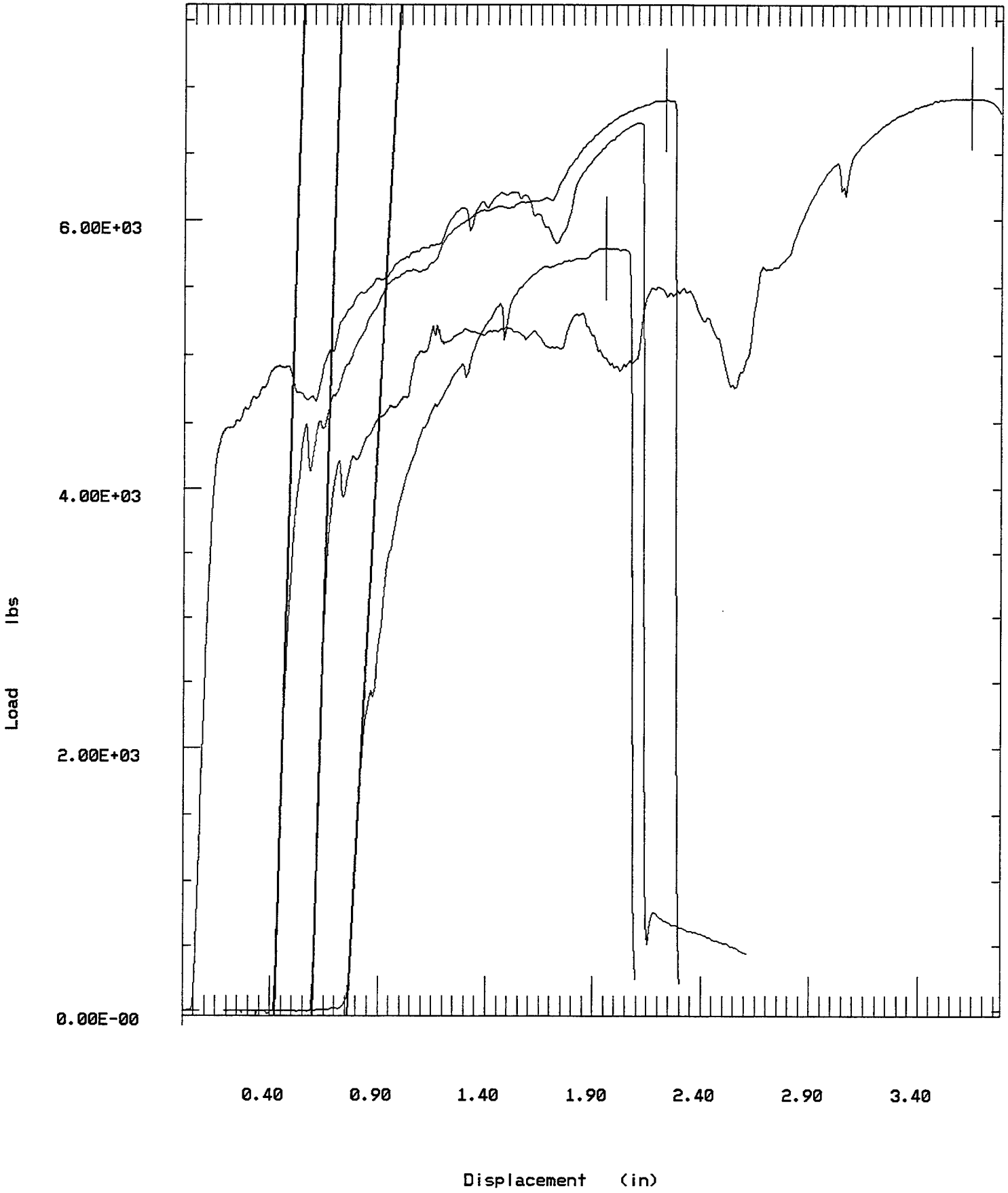

**SIGNODE PAINTED SEAL
WITH 3/4-INCH
ACME PACKAGING CORPORATION
GALVANIZED STRAP 34HOC**

USADACS
SIOAC_DEV
Savanna, IL

General Tensile Test - US Customary Units

Test type: Tensile Instron Corporation
Series IX Automated Materials Testing System 6.03
Operator name: HAAS Test Date: 15 Aug 1996

Sample Identification: SIG2-1-4 Sample Type: ASTM
Interface Type: Data Systems Adapter

Machine Parameters of test:
 Crosshead Speed (in/min): 2.0000 Humidity (%): 50
 Full Scale Load Range (lbs): 20000.0000 Temperature (deg. F): 73

Dimensions:
 Width (in) Sample .75000
 Thickness (in) .03500
 Spec gauge len (in) 2.0000
 Grip distance: (in) 8.5000

Out of 5 specimens, 0 excluded.
 Sample comments: 3/4 Inch Galvanized Banding/2-1/4 Inch Signode Clip. 0 Hours Aging

Specimen Number	Load at Peak (lbs)	Stress at Peak (psi)	Displcmnt at Peak (in)	% Strain at Peak (%)	Load at Break (lbs)	Stress at Break (psi)	Displcmnt at Break (in)	% Strain at Break (%)	Load at 0.2% Yield (lbs)
1	3116.	118700.	.5474	27.37	1148.0	43740.	1.611	80.56	1512.
2	2860.	109000.	.2783	13.91	968.7	36900.	3.270	163.50	1794.
3	3075.	117200.	.4943	24.72	1297.0	49400.	1.822	91.09	1486.
4	3004.	114400.	.3149	15.75	1184.0	45110.	1.172	58.59	1661.
5	3127.	119100.	.3570	17.85	1076.0	41000.	1.635	81.75	1809.
Mean:	3036.	115700.	.3984	19.92	1135.0	43230.	1.902	95.09	1652.
Standard Deviation:	110.	4182.	.1167	5.84	122.3	4659.	.801	40.05	152.

Specimen Number	Stress at 0.2% Yield (psi)	Displcmnt at 0.2% Yield (in)	% Strain at 0.2% Yield (%)	Young's Modulus (ksi)	Energy at Yield (lbs-in)	Energy at Break (lbs-in)
1	57600.	.1117	5.584	2186.	47.68	3462.
2	68340.	.1263	6.316	2040.	69.32	5513.
3	56630.	.1007	5.035	2223.	45.44	3566.
4	63260.	.1153	5.767	2382.	52.80	2239.
5	68930.	.1080	5.401	2198.	65.83	2929.

Mean:	62950.	.1124	5.621	2206.	56.21	3542.
Standard Deviation:	5777.	.0095	.474	122.	10.78	1221.

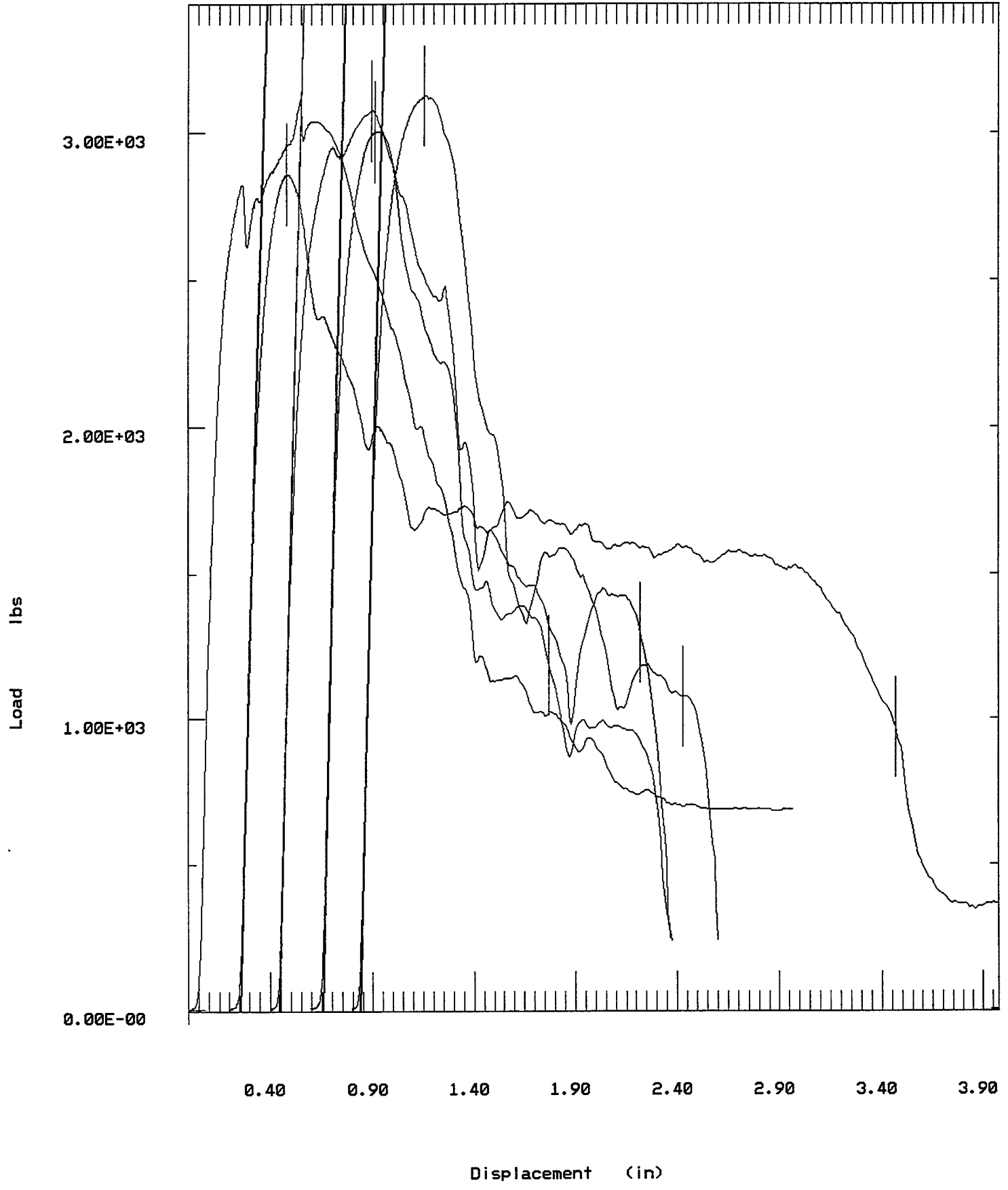

USADACS
SIOAC_DEV
Savanna, IL

General Tensile Test - US Customary Units

Test type: Tensile Instron Corporation
Series IX Automated Materials Testing System 6.03
 Operator name: HAAS Test Date: 15 Aug 1996
 Sample Identification: 3-4GALV1 Sample Type: ASTM
 Interface Type: Data Systems Adapter
 Machine Parameters of test:
 Sample Rate (pts/sec): 18.206 Humidity (%): 50
 Crosshead Speed (in/min): 2.0000 Temperature (deg. F): 73
 Full Scale Load Range (lbs): 20000.0000

Dimensions:

	Sample
Width (in)	.75000
Thickness (in)	.03500
Spec gauge len (in)	2.0000
Grip distance: (in)	8.5000

Out of 5 specimens, 0 excluded.

Sample comments: 3/4 Inch Galvanized Banding\No Seal 0 Hours Aging 0 Hours Aging

Specimen Number	Load at Peak (lbs)	Stress at Peak (psi)	Displcment at Peak (in)	% Strain at Peak (%)	Load at Break (lbs)	Stress at Break (psi)	Displcment at Break (in)	% Strain at Break (%)	Load at 0.2% Yield (lbs)
1	4034.	153700.	.8422	42.11	1497.	57020.	.9191	45.95	2199.
2	3967.	151100.	1.0780	53.92	1615.	61510.	1.3050	65.27	2030.
3	4044.	154100.	.8971	44.86	1640.	62480.	1.1190	55.93	2168.
4	4013.	152900.	.7525	37.62	1599.	60920.	1.0230	51.17	2481.
5	4013.	152900.	.8935	44.67	1363.	51940.	1.1280	56.39	2455.
Mean:	4014.	152900.	.8927	44.64	1543.	58770.	1.0990	54.94	2267.
Standard Deviation:	30.	1125.	.1191	5.95	114.	4349.	.1431	7.15	195.

Specimen Number	Stress at 0.2% Yield (psi)	Displcment at 0.2% Yield (in)	% Strain at 0.2% Yield (%)	Young's Modulus (ksi)	Energy at Yield (lbs-in)	Energy at Break (lbs-in)
1	83770.	.0787	3.936	3618.	60.29	3080.
2	77320.	.0787	3.936	3557.	52.10	4483.
3	82600.	.0769	3.845	3474.	60.42	3901.
4	94510.	.0970	4.852	3532.	76.85	3527.
5	93530.	.0824	4.119	3695.	72.00	3967.

Mean:	86340.	.0828	4.138	3575.	64.33	3792.
Standard						
Deviation:	7422.	.0082	.411	85.	9.96	524.

3-46ALV1

ALL

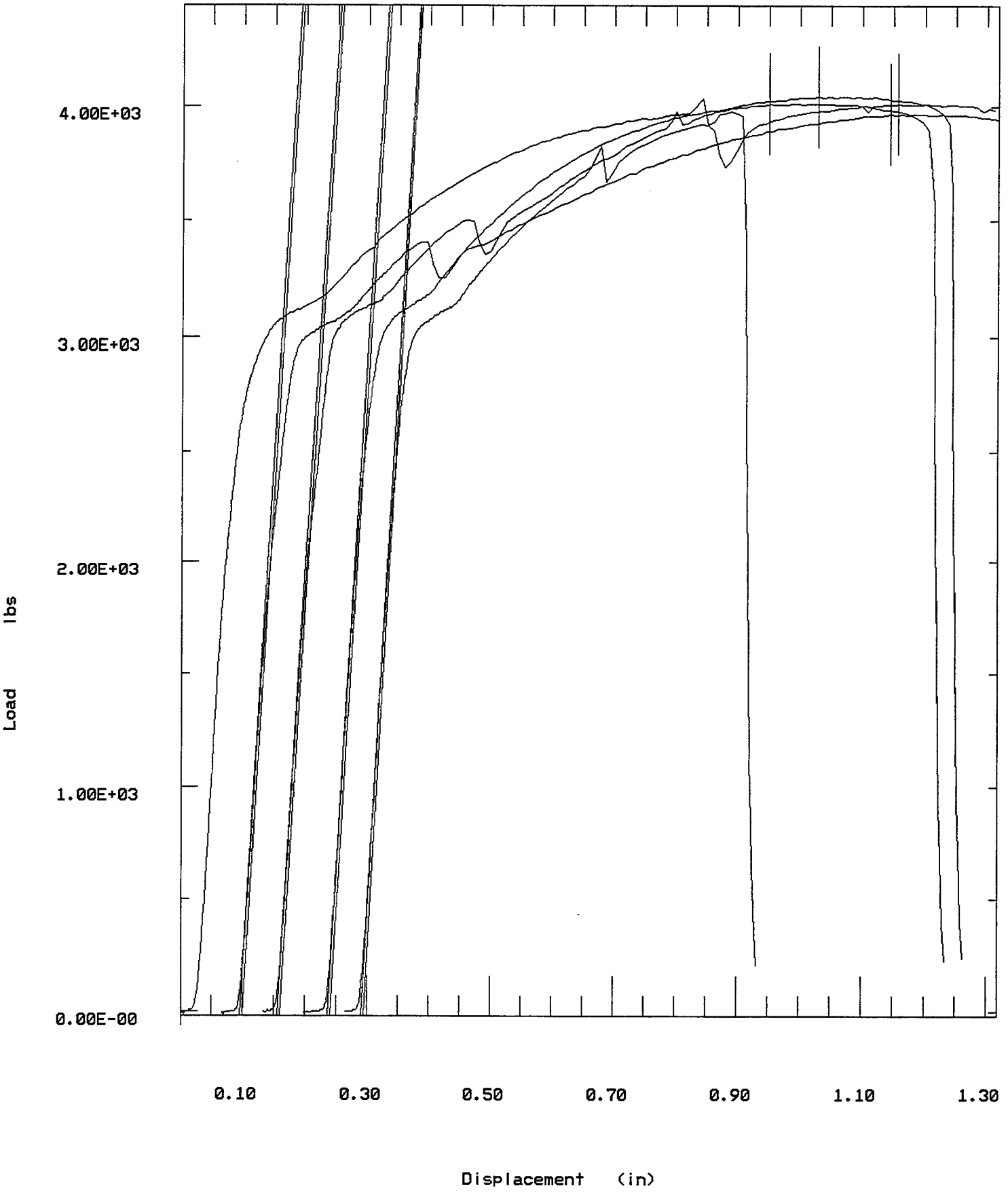

**SIGNODE PAINTED AUTO SEAL
WITH 3/4-INCH
ACME PACKAGING CORPORATION
GALVANIZED STRAP 34AHP**

USADACS
SIOAC_DEV
Savanna, IL

General Tensile Test - US Customary Units

Test type: Tensile Instron Corporation
Series IX Automated Materials Testing System 6.03
 Operator name: HAAS Test Date: 15 Aug 1996

Sample Identification: SIG34AHP Sample Type: ASTM
 Interface Type: Data Systems Adapter

Machine Parameters of test:
 Sample Rate (pts/sec): 18.206 Humidity (%): 50
 Crosshead Speed (in/min): 2.0000 Temperature (deg. F): 73
 Full Scale Load Range (lbs): 20000.0000

Dimensions:
Sample
 Width (in) .75000
 Thickness (in) .03500
 Spec gauge len (in) 2.0000
 Grip distance: (in) 8.5000

Out of 5 specimens, 0 excluded.
 Sample comments: 3/4 Inch Galvanized Strap\1-1/2 Inch Signode Clip: 34AHP 0 Hours Aging

Specimen Number	Load at Peak (lbs)	Stress at Peak (psi)	Displcment at Peak (in)	% Strain at Peak (%)	Load at Break (lbs)	Stress at Break (psi)	Displcment at Break (in)	% Strain at Break (%)	Load at 0.2% Yield (lbs)
1	3270.	124600.	.2636	13.180	1178.0	44890.	.3003	15.01	1665.
2	3490.	133000.	.2838	14.190	1214.0	46260.	.2966	14.83	2250.
3	3316.	126300.	.2453	12.270	1189.0	45280.	.2911	14.56	1911.
4	2701.	102900.	.1886	9.429	1009.0	38450.	.4815	24.08	1665.
5	2696.	102700.	.1996	9.978	906.7	34540.	.4833	24.17	1752.
Mean:	3094.	117900.	.2362	11.810	1099.0	41880.	.3706	18.53	1849.
Standard Deviation:	371.	14130.	.0410	2.048	134.8	5134.	.1022	5.11	246.

Specimen Number	Stress at 0.2% Yield (psi)	Displcment at 0.2% Yield (in)	% Strain at 0.2% Yield (%)	Young's Modulus (ksi)	Energy at Yield (lbs-in)	Energy at Break (lbs-in)
1	63440.	.0751	3.753	3222.	40.12	693.1
2	85700.	.0861	4.303	3596.	63.89	731.0
3	72810.	.0806	4.028	3238.	51.15	691.5
4	63440.	.0769	3.845	2697.	46.02	884.0
5	66760.	.0824	4.119	2712.	51.21	879.6

Mean:	70430.	.0802	4.010	3093.	50.48	775.9
Standard						
Deviation:	9355.	.0044	.219	385.	8.77	98.0

SIG34AHP

ALL

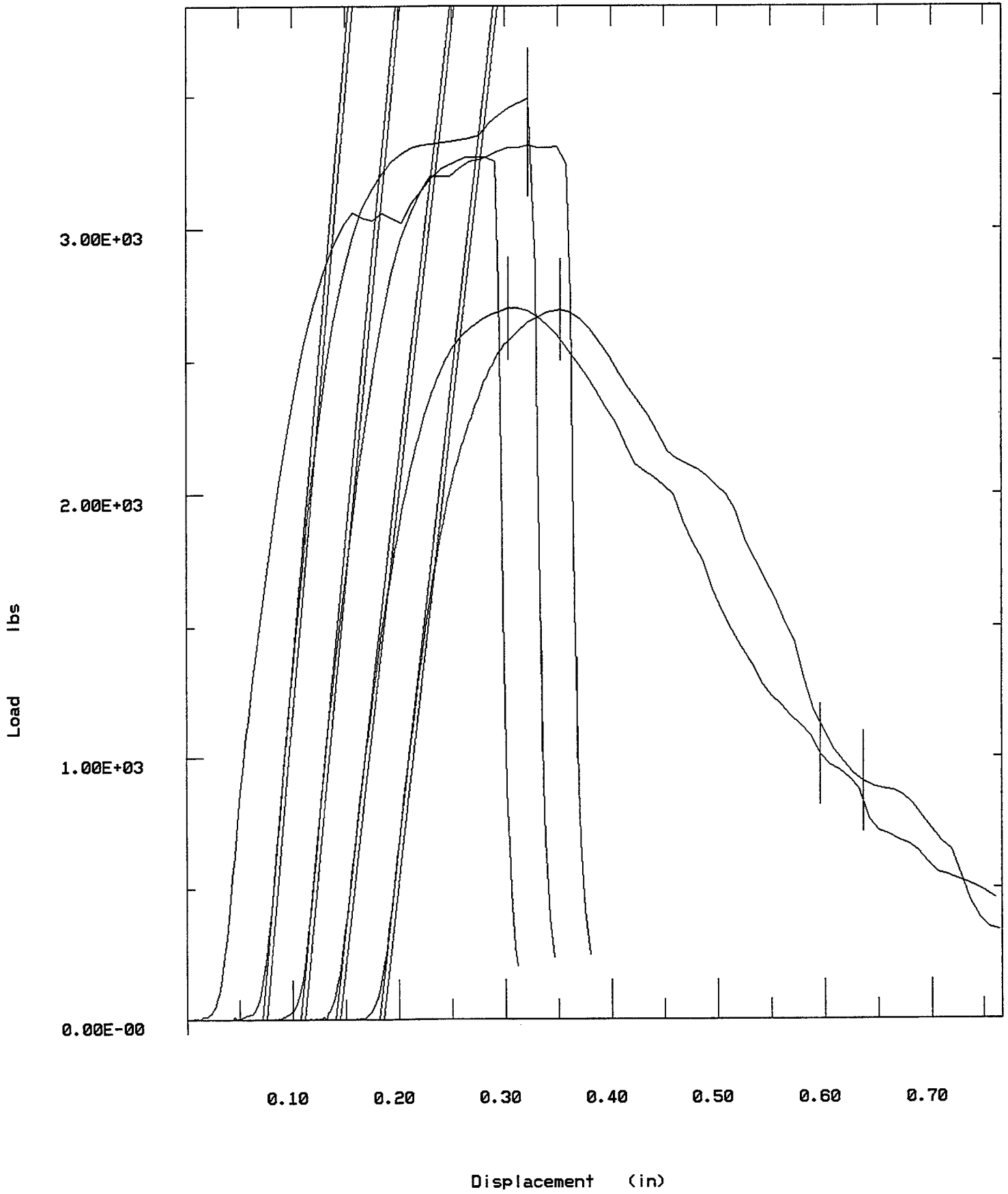

USADACS
SIOAC_DEV
Savanna, IL

General Tensile Test - US Customary Units

Test type: Tensile Instron Corporation
Series IX Automated Materials Testing System 6.03
 Operator name: HAAS Test Date: 15 Aug 1996

Sample Identification: GAL34AHP Sample Type: ASTM

Interface Type: Data Systems Adapter

Machine Parameters of test:

Sample Rate (pts/sec): 18.206	Humidity (%): 50
Crosshead Speed (in/min): 2.0000	Temperature (deg. F): 73
Full Scale Load Range (lbs): 20000.0000	

Dimensions:

	Sample
Width (in)	.75000
Thickness (in)	.03500
Spec gauge len (in)	2.0000
Grip distance: (in)	8.5000

Out of 5 specimens, 0 excluded.

Sample comments: 3/4 Inch Galvanized Strap 34AHP\No Seal 0 Hours Aging34AHP 0 Hours Aging

Specimen Number	Load at Peak (lbs)	Stress at Peak (psi)	Displcment at Peak (in)	% Strain at Peak (%)	Load at Break (lbs)	Stress at Break (psi)	Displcment at Break (in)	% Strain at Break (%)	Load at 0.2% Yield (lbs)
1	3993.	152100.	1.1310	56.57	1543.	58760.	1.298	64.90	1958.
2	3982.	151700.	.9136	45.68	1343.	51150.	1.111	55.57	2234.
3	3987.	151900.	1.0880	54.38	1338.	50950.	1.326	66.28	2234.
4	4013.	152900.	.8898	44.49	1625.	61890.	1.045	52.27	2168.
5	3957.	150700.	.9209	46.05	1430.	54470.	1.069	53.46	2204.
Mean:	3986.	151900.	.9887	49.43	1455.	55440.	1.170	58.50	2160.
Standard Deviation:	20.	774.	.1120	5.60	126.	4799.	.132	6.60	116.

Specimen Number	Stress at 0.2% Yield (psi)	Displcment at 0.2% Yield (in)	% Strain at 0.2% Yield (%)	Young's Modulus (ksi)	Energy at Yield (lbs-in)	Energy at Break (lbs-in)
1	74580.	.0714	3.570	3283.	52.17	4514.
2	85120.	.0751	3.753	3462.	64.07	3872.
3	85120.	.0714	3.570	3527.	62.66	4643.
4	82590.	.0732	3.662	3497.	60.30	3661.
5	83950.	.0769	3.845	3451.	63.14	3669.

Mean:	82270.	.0736	3.680	3444.	60.47	4072.
Standard Deviation:	4426.	.0024	.119	95.	4.84	472.

GAL34AHP

ALL

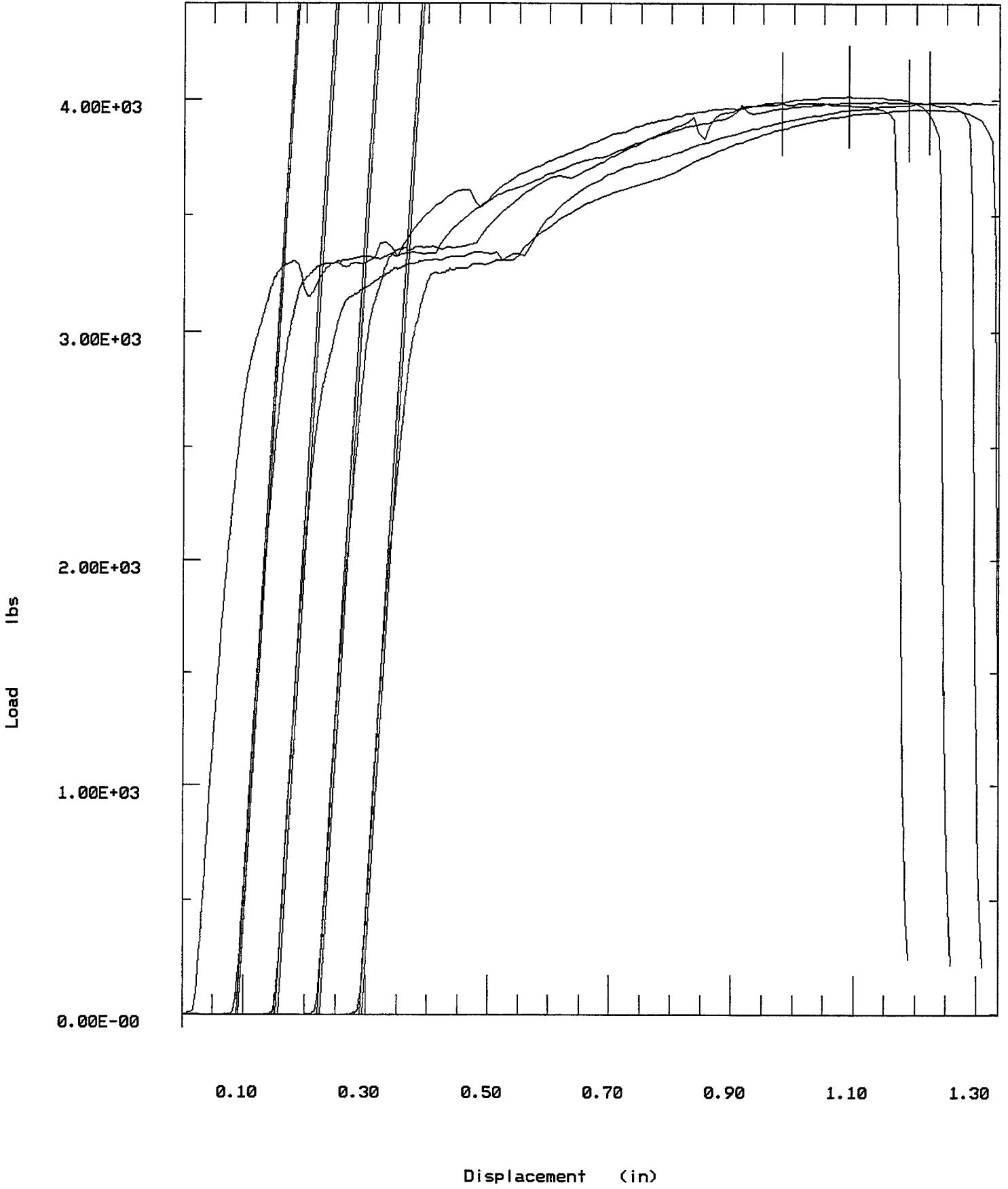

PART 8

APPENDIX

**SUMMARY OF
TEST DATA**

DELTA PAINTED SEAL SUMMARY

<u>Hours Aging</u>	<u>Average Load</u>	<u>Standard Deviation</u>
0	5532	273
341	5780	69
732	5692	156
1141	5730	102
1497	5659	88

1-1/4 INCH ACME GALVANIZED STRAP SUMMARY

<u>Hours Aging</u>	<u>Average Load</u>	<u>Standard Deviation.</u>
0	6829	384
341	7016	32
732	6660	137
1141	6930	23
1497	7000	54

SUMMARY OF STRAPPING EXPOSED TO 0 HOURS AGING

<u>Description</u>	<u>Average Load</u>	<u>Standard Deviation</u>
1-1/4" Galv w/Delta Seal	5532	273
1-1/4" Galv/No Seal	6829	384
1-1/4" Galv w/Stanley Seal	5144	465
1-1/4" Galv/No Seal	6588	539
3/4" Galv w/Seal 34HOC	3036	110
3/4" Galv/No Seal 34HOC	4014	30
3/4" Galv w/Seal 34AHP	3094	371
3/4" Galv/No Seal 34AHP	3986	20

Steel Strapping Evaluation

SAMPLES AND RESULTS

1. 1-1/4" Galvanized Strapping/Delta Painted Seal Style III
0 Hours Accelerated Aging

<u>Sample</u>	<u>Maximum Load (lbs.)</u>	<u>Stress (psi)</u>	<u>Method of Failure</u>
1	5693	130,100	Seal Opened
2	5633	128,800	Seal Opened
3	5623	128,500	Seal Opened
4	5666	129,500	Seal Opened
5	5046	115,300	Seal Opened
Avg	5532 (273)*	126,500 (6244)*	

2. 1-1/4" Galvanized Strapping/Delta Painted Seal Style III
341 Hours Accelerated Aging

<u>Sample</u>	<u>Maximum Load (lbs.)</u>	<u>Stress (psi)</u>	<u>Method of Failure</u>
1	5721	130,800	Seal Opened
2	5856	133,900	Band Broke @ Seal
3	5764	131,700	Seal Opened
Avg	5780 (69)*	132,100 (1587)*	

3. 1-1/4" Galvanized Strapping/Delta Painted Seal Style III
732 Hours Accelerated Aging

<u>Sample</u>	<u>Maximum Load (lbs.)</u>	<u>Stress (psi)</u>	<u>Method of Failure</u>
1	5872	134,200	Band Broke @ Seal
2	5594	127,900	Seal Opened
3	5611	128,200	Seal Opened
Avg	5692 (156)*	130,100 (3557)*	

4. 1-1/4" Galvanized Strapping/Delta Painted Seal Style III
1140 Hours Accelerated Aging

<u>Sample</u>	<u>Maximum Load (lbs.)</u>	<u>Stress (psi)</u>	<u>Method of Failure</u>
1	5688	130,000	Seal Opened
2	5655	129,300	Seal Opened
3	5846	133,600	Seal Opened
Avg	5730 (102)*	131,000 (2326)*	

5. 1-1/4" Galvanized Strapping/Delta Painted Seal Style III
1497 Hours Accelerated Aging

<u>Sample</u>	<u>Maximum Load (lbs.)</u>	<u>Stress (psi)</u>	<u>Method of Failure</u>
1	5563	127,200	Seal Opened
2	5737	131,100	Band Broke @ Seal
3	5678	129,800	Seal Opened
Avg	5659 (88)*	129,400 (2021)*	

* Standard Deviation

6. 1-1/4" Galvanized Strapping/No Seal
0 Hours Accelerated Aging

<u>Sample</u>	<u>Maximum Load (lbs.)</u>	<u>Stress (psi)</u>	<u>Method of Failure</u>
1	6399	146,300	Band Broke @ Jaws
2	7136	163,100	Band Broke @ Jaws
3	Sample Slipped, No Reliable Data		
4	6953	158,900	Band Broke @ Center
5	Sample Slipped, No Reliable Data		
Avg	6829 (384)*	156,100 (8766)*	

7. 1-1/4" Galvanized Strapping/No Seal
341 Hours Accelerated Aging

<u>Sample</u>	<u>Maximum Load (lbs.)</u>	<u>Stress (psi)</u>	<u>Method of Failure</u>
1	6979	159,500	Band Broke @ Center
2	7032	160,700	Band Broke @ Center
3	7037	160,900	Band Broke @ Jaws
Avg	7016 (32)*	160,367 (757)*	

8. 1-1/4" Galvanized Strapping/No Seal
732 Hours Accelerated Aging

<u>Sample</u>	<u>Maximum Load (lbs.)</u>	<u>Stress (psi)</u>	<u>Method of Failure</u>
1	6563	150,000	Band Broke in Jaws
2	Sample Slipped, No Reliable Data		
3	6757	154,400	Band Broke in Jaws
Avg	6660 (137)*	152,200 (3128)*	

9. 1-1/4" Galvanized Strapping/No Seal
1140 Hours Accelerated Aging

<u>Sample</u>	<u>Maximum Load (lbs.)</u>	<u>Stress (psi)</u>	<u>Method of Failure</u>
1	Sample Slipped, No Reliable Data		
2	6914	158,000	Band Broke in Center
3	6946	158,800	Band Broke in Center
Avg	6930 (23)*	158,400 (521)*	

10. 1-1/4" Galvanized Strapping/No Seal
1497 Hours Accelerated Aging

<u>Sample</u>	<u>Maximum Load (lbs.)</u>	<u>Stress (psi)</u>	<u>Method of Failure</u>
1	6946	158,800	Band Broke in Center
2	7054	161,200	Band Broke Near Jaws
3	7000	160,000	Band Broke in Center
Avg	7000 (54)*	160,000 (1229)*	

* Standard Deviation

11. 1-1/4" Acme Galvanized Strapping/Stanley Galvanized Seal
0 Hours Accelerated Aging

<u>Sample</u>	<u>Maximum Load (lbs.)</u>	<u>Stress (psi)</u>	<u>Method of Failure</u>
1	5231	119,600	Stripped Band @ Seal
2	4903	112,100	Stripped Band @ Seal
3	4478	102,400	Stripped Band @ Seal
4	5656	129,300	Stripped Band @ Seal
5	5452	124,600	Stripped Band @ Seal
Avg	5144 (465)*	117,600 (10,365)*	

12. 1-1/4" Acme Galvanized Strapping/No Seal Strap accompanied #11
0 Hours Accelerated Aging

<u>Sample</u>	<u>Maximum Load (lbs.)</u>	<u>Stress (psi)</u>	<u>Method of Failure</u>
1	6733	153,900	Band Broke in Jaws
2	5789	132,300	Band Broke in Jaws
3	6907	157,900	Band Broke @ Jaws
4	Sample Slipped, No Reliable Data		
5	6922	154,400	Band Broke Near Jaws
Avg	6588 (539)*	150,600 (12,330)*	

13. 3/4" Galvanized Strapping/Signode Painted Clip (2-1/4" in length) 34HOC
0 Hours Accelerated Aging

<u>Sample</u>	<u>Maximum Load (lbs.)</u>	<u>Stress (psi)</u>	<u>Method of Failure</u>
1	3116	118,700	Stripped Band @ Seal
2	2860	109,000	Stripped Band @ Seal
3	3075	117,200	Stripped Band @ Seal
4	3004	114,400	Stripped Band @ Seal
5	3127	119,100	Stripped Band @ Seal
Avg	3036 (110)*	115,700 (4182)*	

14. 3/4" Galvanized Strapping/No Seal Accompanied #13
0 Hours Accelerated Aging

<u>Sample</u>	<u>Maximum Load (lbs.)</u>	<u>Stress (psi)</u>	<u>Method of Failure</u>
1	4034	153,700	Band Broke in Jaws
2	3967	151,100	Band Broke @ Center
3	4044	154,100	Band Broke @ Center
4	4013	152,900	Band Broke @ Center
5	4013	152,900	Band Broke @ Center
Avg	4014 (30)*	152,900 (1125)*	

* Standard Deviation

15. 3/4" Galvanized Strapping/Signode Painted Auto Clip (1-1/2" in length)
 0 Hours Accelerated Aging 34AHP

<u>Sample</u>	<u>Maximum Load (lbs.)</u>	<u>Stress (psi)</u>	<u>Method of Failure</u>
1	3270	124,600	Band Broke @ Jaws
2	3490	133,000	Band Broke @ Seal
3	3316	129,300	Band Broke @ Seal
4	2701	102,900	Seal Opened
5	2696	102,700	Seal Opened
Avg	3094 (371)*	117,900 (14,130)*	

16. 3/4" Galvanized Strapping/No Seal Accompanied #15
 0 Hours Accelerated Aging

<u>Sample</u>	<u>Maximum Load (lbs.)</u>	<u>Stress (psi)</u>	<u>Method of Failure</u>
1	3993	152,100	Band Broke @ Center
2	3982	151,700	Band Broke @ Center
3	3987	151,900	Band Broke @ Center
4	4013	152,900	Band Broke @ Center
5	3957	150,700	Band Broke @ Center
Avg	3986 (20)*	151,900 (774)*	

* Standard Deviation

MASON & HANGER - SILAS MASON CO., INC.
TEST RESULTS

MASON & HANGER - SILAS MASON CO., INC.
IOWA ARMY AMMUNITION PLANT

REPORT OF TEST RESULTS FOR STRENGTH OF STEEL STRAPPING
AND STRAPPING SEAL JOINTS

Sealer/Crimper:

Serial # 13852 Pressure 90 psig. Size: 1-1/4" 3/4"

Test Type:

- | | | | |
|---------------------------------------------------------------------|--------------|--------------------------------------------|---------------------------------|
| <input type="checkbox"/> New Strap | P.O. # _____ | <input type="checkbox"/> Accept | <input type="checkbox"/> Reject |
| <input type="checkbox"/> New Seals | P.O. # _____ | <input type="checkbox"/> Accept | <input type="checkbox"/> Reject |
| <input type="checkbox"/> Strapper/Sealer Repair Verification | | <input type="checkbox"/> Accept | <input type="checkbox"/> Reject |
| <input type="checkbox"/> Strapper/Sealer Qualification | | <input type="checkbox"/> Accept | <input type="checkbox"/> Reject |
| <input checked="" type="checkbox"/> Strapper/Sealer Recertification | | <input checked="" type="checkbox"/> Accept | <input type="checkbox"/> Reject |

Strap Tension Results

Sealed Joint Results

TEST SAMPLE NUMBER	THICKNESS (INCHES)	STRAP WIDTH (INCHES)	ELONGATION (INCHES)	BREAKING STRENGTH (POUNDS)	JOINT EFFICIENCY (POUNDS)
# 1	.034	.755	.562	3500	2800
# 2	.034	.754	.625	3500	2600
# 3	.035	.754	.375	3500	2600

Sampled By: J. Durbin # 20754 NAME & BADGE Date: 2-27-96 Location: 2-01

Tested By: D. Mohr # 15121 NAME & BADGE Date: 3-7-96 Location: 1-84

Due for Next Testing 3-20-96 at Level I II III

Machine Tested On: Satec Other

Machine Setting: 12 K Medium 3.0 Pot Speed

Calibration Void Date: 4-23-96

Remarks From Line 2-01 Cons F/120MM M865

Used 3/4 in Signode Clips F/ This Test -

34 HOC

MASON & HANGER - SILAS MASON CO., INC.
IOWA ARMY AMMUNITION PLANT

REPORT OF TEST RESULTS FOR STRENGTH OF STEEL STRAPPING
AND STRAPPING SEAL JOINTS

Sealer/Crimper:

Serial # 13852 Pressure 90 psig. Size: 1-1/4" 3/4"

Test Type:

- | | | | |
|---------------------------------------------------------------------|--------------|--------------------------------------------|---------------------------------|
| <input type="checkbox"/> New Strap | P.O. # _____ | <input type="checkbox"/> Accept | <input type="checkbox"/> Reject |
| <input type="checkbox"/> New Seals | P.O. # _____ | <input type="checkbox"/> Accept | <input type="checkbox"/> Reject |
| <input type="checkbox"/> Strapper/Sealer Repair Verification | | <input type="checkbox"/> Accept | <input type="checkbox"/> Reject |
| <input type="checkbox"/> Strapper/Sealer Qualification | | <input type="checkbox"/> Accept | <input type="checkbox"/> Reject |
| <input checked="" type="checkbox"/> Strapper/Sealer Recertification | | <input checked="" type="checkbox"/> Accept | <input type="checkbox"/> Reject |

Strap Tension Results

Sealed Joint Results

TEST SAMPLE NUMBER	THICKNESS (INCHES)	STRAP WIDTH (INCHES)	ELONGATION (INCHES)	BREAKING STRENGTH (POUNDS)	JOINT EFFICIENCY (POUNDS)
# 1	.034	.752	.500	3500	2600
# 2	.034	.752	.531	3600	2700
# 3	.033	.752	.500	3600	2500

Sampled By: J. Durbin # 20754 Date: 2-19-96 Location: 2-01
NAME & BADGE

Tested By: D. Mohr # 15121 Date: 2-22-96 Location: 1-84
NAME & BADGE

Due for Next Testing 3-7-96 at Level I II III

Machine Tested On: Satec Other

Machine Setting: 12 K Medium 3.0 Pot Speed

Calibration Void Date: 4-23-96

Remarks From Line 2-01 Cows F/120MM M865

Used 3/4in Signode Clips F/ This Test.

MASON & HANGER - SILAS MASON CO., INC.
IOWA ARMY AMMUNITION PLANT

REPORT OF TEST RESULTS FOR STRENGTH OF STEEL STRAPPING
AND STRAPPING SEAL JOINTS

Sealer/Crimper:

Serial # 13852 Pressure 90 psig. Size: 1-1/4" 3/4"

Test Type:

- | | | | |
|---------------------------------------------------------------------|--------------|--------------------------------------------|---------------------------------|
| <input type="checkbox"/> New Strap | P.O. # _____ | <input type="checkbox"/> Accept | <input type="checkbox"/> Reject |
| <input type="checkbox"/> New Seals | P.O. # _____ | <input type="checkbox"/> Accept | <input type="checkbox"/> Reject |
| <input type="checkbox"/> Strapper/Sealer Repair Verification | | <input type="checkbox"/> Accept | <input type="checkbox"/> Reject |
| <input type="checkbox"/> Strapper/Sealer Qualification | | <input type="checkbox"/> Accept | <input type="checkbox"/> Reject |
| <input checked="" type="checkbox"/> Strapper/Sealer Recertification | | <input checked="" type="checkbox"/> Accept | <input type="checkbox"/> Reject |

Strap Tension Results

Sealed Joint Results

TEST SAMPLE NUMBER	THICKNESS (INCHES)	STRAP WIDTH (INCHES)	ELONGATION (INCHES)	BREAKING STRENGTH (POUNDS)	JOINT EFFICIENCY (POUNDS)
# 1	.035	.754	.437	3300	2800
# 2	.035	.755	.625	3300	2600
# 3	.036	.754	.625	3300	2600

Sampled By: J. Durbin # 20754 Date: 1-30-96 Location: 2-01
NAME & BADGE

Tested By: D. Mohr # 15121 Date: 2-8-96 Location: 1-84
NAME & BADGE

Due for Next Testing 2-22-96 at Level I II III

Machine Tested On: Satec Other

Machine Setting: 12 K Medium 3.0 Pot Speed

Calibration Void Date: 4-23-96

Remarks From Line 2-01 Cons F/120MM M865
Used 3/4in Signode Clips F/ This Test.

MASON & HANGER - SILAS MASON CO., INC.
IOWA ARMY AMMUNITION PLANT

REPORT OF TEST RESULTS FOR STRENGTH OF STEEL STRAPPING
AND STRAPPING SEAL JOINTS

Sealer/Crimper:

Serial # 13852 Pressure 90 psig. Size: 1-1/4" 3/4"

Test Type:

- | | | | |
|---------------------------------------------------------------------|--------------|--------------------------------------------|---------------------------------|
| <input type="checkbox"/> New Strap | P.O. # _____ | <input type="checkbox"/> Accept | <input type="checkbox"/> Reject |
| <input type="checkbox"/> New Seals | P.O. # _____ | <input type="checkbox"/> Accept | <input type="checkbox"/> Reject |
| <input type="checkbox"/> Strapper/Sealer Repair Verification | | <input type="checkbox"/> Accept | <input type="checkbox"/> Reject |
| <input type="checkbox"/> Strapper/Sealer Qualification | | <input type="checkbox"/> Accept | <input type="checkbox"/> Reject |
| <input checked="" type="checkbox"/> Strapper/Sealer Recertification | | <input checked="" type="checkbox"/> Accept | <input type="checkbox"/> Reject |

Strap Tension Results

Sealed Joint Results

TEST SAMPLE NUMBER	THICKNESS (INCHES)	STRAP WIDTH (INCHES)	ELONGATION (INCHES)	BREAKING STRENGTH (POUNDS)	JOINT EFFICIENCY (POUNDS)
# 1	.034	.755	.593	3400	2600
# 2	.035	.755	.593	3400	2800
# 3	.035	.755	.593	3400	2800

Sampled By: J. Durbin #20754 Date: 1-17-96 Location: 2-01
NAME & BADGE

Tested By: D. Mokr #15121 Date: 1-18-96 Location: 1-84
NAME & BADGE

Due for Next Testing 1-25-96 at Level I II III

Machine Tested On: Satec Other

Machine Setting: 12 K Medium 3.0 Pot Speed

Calibration Void Date: 4-23-96

Remarks From Line 2-01 Caus F/120MM M865

Used Signode 3/4" Clips F/This Test.

MASON & HANGER - SILAS MASON CO., INC.
IOWA ARMY AMMUNITION PLANT

REPORT OF TEST RESULTS FOR STRENGTH OF STEEL STRAP
AND STRAPPING SEAL JOINTS

Sealer/Crimper:

Serial # 13852 Pressure 90 psig. Size: 1-1/4"

Test Type:

- | | | | |
|---------------------------------------------------------------------|--------------|--------------------------------------------|--------------------------|
| <input type="checkbox"/> New Strap | P.O. # _____ | <input type="checkbox"/> Accept | <input type="checkbox"/> |
| <input type="checkbox"/> New Seals | P.O. # _____ | <input type="checkbox"/> Accept | <input type="checkbox"/> |
| <input type="checkbox"/> Strapper/Sealer Repair Verification | | <input type="checkbox"/> Accept | <input type="checkbox"/> |
| <input type="checkbox"/> Strapper/Sealer Qualification | | <input type="checkbox"/> Accept | <input type="checkbox"/> |
| <input checked="" type="checkbox"/> Strapper/Sealer Recertification | | <input checked="" type="checkbox"/> Accept | <input type="checkbox"/> |

Strap Tension Results

TEST SAMPLE NUMBER	THICKNESS (INCHES)	STRAP WIDTH (INCHES)	ELONGATION (INCHES)	BREAKING STRENGTH (POUNDS)	JOINT EFFICIENCY (%)
# 1	.034	.755	.562	3500	80
# 2	.034	.754	.625	3500	76
# 3	.035	.754	.375	3500	160

Sampled By: J. Durbin # 20754 NAME & BADGE Date: 2-27-96 Location: 2-0

Tested By: D. Mohr # 15121 NAME & BADGE Date: 3-7-96 Location: 1-8

Due for Next Testing 3-20-96 at Level I II III

Machine Tested On: Satec Other

Machine Setting: 12 K Medium 3.0 Pot Speed

Calibration Void Date: 4-23-96

Remarks From Line 2-01 Cans F/120MM M865

Used 3/4 in Signode Clips F/ This Test -

34 H02

MASON & HANGER - SILAS MASON CO., INC.
IOWA ARMY AMMUNITION PLANT

REPORT OF TEST RESULTS FOR STRENGTH OF STEEL STRAPPING
AND STRAPPING SEAL JOINTS

Sealer/Crimper:

Serial # 13852 Pressure 90 psig. Size: 1-1/4" 3/4"

Test Type:

- | | | | |
|---------------------------------------------------------------------|--------------|--------------------------------------------|---------------------------------|
| <input type="checkbox"/> New Strap | P.O. # _____ | <input type="checkbox"/> Accept | <input type="checkbox"/> Reject |
| <input type="checkbox"/> New Seals | P.O. # _____ | <input type="checkbox"/> Accept | <input type="checkbox"/> Reject |
| <input type="checkbox"/> Strapper/Sealer Repair Verification | | <input type="checkbox"/> Accept | <input type="checkbox"/> Reject |
| <input type="checkbox"/> Strapper/Sealer Qualification | | <input type="checkbox"/> Accept | <input type="checkbox"/> Reject |
| <input checked="" type="checkbox"/> Strapper/Sealer Recertification | | <input checked="" type="checkbox"/> Accept | <input type="checkbox"/> Reject |

Strap Tension Results

Sealed Joint Results

TEST SAMPLE NUMBER	THICKNESS (INCHES)	STRAP WIDTH (INCHES)	ELONGATION (INCHES)	BREAKING STRENGTH (POUNDS)	JOINT EFFICIENCY (POUNDS)
# 1	.035	.755	.531	3500	2600
# 2	.035	.754	.593	3500	2800
# 3	.034	.754	.562	3500	2700

Sampled By: J. Durbin #20754 Date: 1-8-96 Location: 2-01
NAME & BADGE

Tested By: D. Mohr #15121 Date: 1-9-96 Location: 1-84
NAME & BADGE

Due for Next Testing 1-16-96 at Level I II III

Machine Tested On: Satec Other

Machine Setting: 12 K Medium 3.0 Pot Speed

Calibration Void Date: 4-23-96

Remarks From Line 2-01 Cons F/120MM, H865

MASON & HANGER - SILAS MASON CO., INC.
IOWA ARMY AMMUNITION PLANT

REPORT OF TEST RESULTS FOR STRENGTH OF STEEL STRAPPING
AND STRAPPING SEAL JOINTS

Sealer/Crimper:

Serial # 13852 Pressure 90 psig. Size: 1-1/4" 3/4"

Test Type:

- | | | | |
|---------------------------------------------------------------------|--------------|--------------------------------------------|---------------------------------|
| <input type="checkbox"/> New Strap | P.O. # _____ | <input type="checkbox"/> Accept | <input type="checkbox"/> Reject |
| <input type="checkbox"/> New Seals | P.O. # _____ | <input type="checkbox"/> Accept | <input type="checkbox"/> Reject |
| <input type="checkbox"/> Strapper/Sealer Repair Verification | | <input type="checkbox"/> Accept | <input type="checkbox"/> Reject |
| <input type="checkbox"/> Strapper/Sealer Qualification | | <input type="checkbox"/> Accept | <input type="checkbox"/> Reject |
| <input checked="" type="checkbox"/> Strapper/Sealer Recertification | | <input checked="" type="checkbox"/> Accept | <input type="checkbox"/> Reject |

Strap Tension Results

Sealed Joint Results

TEST SAMPLE NUMBER	THICKNESS (INCHES)	STRAP WIDTH (INCHES)	ELONGATION (INCHES)	BREAKING STRENGTH (POUNDS)	JOINT EFFICIENCY (POUNDS)
# 1	.034	.752	.531	3400	2600
# 2	.034	.751	.500	3400	2700
# 3	.035	.752	.531	3400	2800

Sampled By: J. Durbin #20754 Date: 1-2-96 Location: 2-01
NAME & BADGE

Tested By: D. Mohr #15121 Date: 1-3-96 Location: 1-84
NAME & BADGE

Due for Next Testing 1-10-96 at Level I II III

Machine Tested On: Satec Other

Machine Setting: 12 K Medium 3.0 Pot Speed

Calibration Void Date: 4-23-95

Remarks From Line 2-01 Cons F/120MM M831A1

MASON & HANGER - SILAS MASON CO., INC.
IOWA ARMY AMMUNITION PLANT

REPORT OF TEST RESULTS FOR STRENGTH OF STEEL STRAPPING
AND STRAPPING SEAL JOINTS

Sealer/Crimper:

Serial # 29291 Pressure 90 psig. Size: 1-1/4" 3/4"

Test Type:

- | | | | |
|---------------------------------------------------------------------|--------------|---------------------------------|---------------------------------|
| <input type="checkbox"/> New Strap | P.O. # _____ | <input type="checkbox"/> Accept | <input type="checkbox"/> Reject |
| <input type="checkbox"/> New Seals | P.O. # _____ | <input type="checkbox"/> Accept | <input type="checkbox"/> Reject |
| <input type="checkbox"/> Strapper/Sealer Repair Verification | | <input type="checkbox"/> Accept | <input type="checkbox"/> Reject |
| <input type="checkbox"/> Strapper/Sealer Qualification | | <input type="checkbox"/> Accept | <input type="checkbox"/> Reject |
| <input checked="" type="checkbox"/> Strapper/Sealer Recertification | | <input type="checkbox"/> Accept | <input type="checkbox"/> Reject |

Strap Tension Results

Sealed Joint Results

TEST SAMPLE NUMBER	THICKNESS (INCHES)	STRAP WIDTH (INCHES)	ELONGATION (INCHES)	BREAKING STRENGTH (POUNDS)	JOINT EFFICIENCY (POUNDS)
# 1	.035	.753	.500	3400	2200
# 2	.035	.753	.562	3500	2200
# 3	.035	.753	.593	3400	2200

Sampled By: P. Williams # 9484 Date: 2-22-96 Location: 3-05-1
NAME & BADGE

Tested By: D. Mohr # 15121 Date: 2-22-96 Location: 1-8H
NAME & BADGE

Due for Next Testing 3-23-96 at Level I II III

Machine Tested On: Satec Other

Machine Setting: 12 K Medium 3.0 Pot Speed

Calibration Void Date: 4-23-96

Remarks From Line 3-05-1 Melt F/40lb Chg.

Used 3/4 in Signode Clips F/This Test

34AHP

MASON & HANGER - SILAS MASON CO., INC.
IOWA ARMY AMMUNITION PLANT

REPORT OF TEST RESULTS FOR STRENGTH OF STEEL STRAPPING
AND STRAPPING SEAL JOINTS

Sealer/Crimper:

Serial # 29291 Pressure 80 psig. Size: 1-1/4" 3/4"

Test Type:

- | | | | |
|---------------------------------------------------------------------|--------------|--------------------------------------------|---------------------------------|
| <input type="checkbox"/> New Strap | P.O. # _____ | <input type="checkbox"/> Accept | <input type="checkbox"/> Reject |
| <input type="checkbox"/> New Seals | P.O. # _____ | <input type="checkbox"/> Accept | <input type="checkbox"/> Reject |
| <input type="checkbox"/> Strapper/Sealer Repair Verification | | <input type="checkbox"/> Accept | <input type="checkbox"/> Reject |
| <input type="checkbox"/> Strapper/Sealer Qualification | | <input type="checkbox"/> Accept | <input type="checkbox"/> Reject |
| <input checked="" type="checkbox"/> Strapper/Sealer Recertification | | <input checked="" type="checkbox"/> Accept | <input type="checkbox"/> Reject |

Strap Tension Results

Sealed Joint Results

TEST SAMPLE NUMBER	THICKNESS (INCHES)	STRAP WIDTH (INCHES)	ELONGATION (INCHES)	BREAKING STRENGTH (POUNDS)	JOINT EFFICIENCY (POUNDS)
# 1	.035	.752	.468	3500	2400
# 2	.035	.751	.406	3500	2300
# 3	.034	.751	.437	3500	2300

Sampled By: G. Gillette # NAME & BADGE Date: 1-23-96 Location: 3-01

Tested By: D. Mohr # 15121 NAME & BADGE Date: 1-24-96 Location: 1-84

Due for Next Testing 2-24-96 at Level I II III

Machine Tested On: Satec Other

Machine Setting: 12 K Medium 3.0 Pot Speed

Calibration Void Date: 4-23-96

Remarks From Line 3-01 Cons F/120MM H04b Chg
Used 3/4in Clips For This Test - Signode

MASON & HANGER - SILAS MASON CO., INC.
IOWA ARMY AMMUNITION PLANT

REPORT OF TEST RESULTS FOR STRENGTH OF STEEL STRAPPING
AND STRAPPING SEAL JOINTS

Sealer/Crimper:

Serial # 29291 Pressure 90 psig. Size: 1-1/4" 3/4"

Test Type:

- | | | | |
|---------------------------------------------------------------------|--------------|--------------------------------------------|---------------------------------|
| <input type="checkbox"/> New Strap | P.O. # _____ | <input type="checkbox"/> Accept | <input type="checkbox"/> Reject |
| <input type="checkbox"/> New Seals | P.O. # _____ | <input type="checkbox"/> Accept | <input type="checkbox"/> Reject |
| <input type="checkbox"/> Strapper/Sealer Repair Verification | | <input type="checkbox"/> Accept | <input type="checkbox"/> Reject |
| <input type="checkbox"/> Strapper/Sealer Qualification | | <input type="checkbox"/> Accept | <input type="checkbox"/> Reject |
| <input checked="" type="checkbox"/> Strapper/Sealer Recertification | | <input checked="" type="checkbox"/> Accept | <input type="checkbox"/> Reject |

Strap Tension Results

Sealed Joint Results

TEST SAMPLE NUMBER	THICKNESS (INCHES)	STRAP WIDTH (INCHES)	ELONGATION (INCHES)	BREAKING STRENGTH (POUNDS)	JOINT EFFICIENCY (POUNDS)
# 1	.033	.751	.468	3500	2400
# 2	.034	.752	.468	3500	2400
# 3	.034	.752	.562	3500	2300

Sampled By: R. Galbraith # 3344 Date: 12-18-95 Location: 3-01
NAME & BADGE

Tested By: D. Mohr # 15121 Date: 12-19-95 Location: 1-84
NAME & BADGE

Due for Next Testing 1-26-96 at Level I II III

Machine Tested On: Satec Other

Machine Setting: 12 K Medium 3.0 Pot Speed

Calibration Void Date: 4-23-96

Remarks From Line 3-01 F/ The 120MM Retrograde.
Extended 1 week Due To The Holiday Week Shutdown From
Dec 24th Thru. The 31st.

MASON & HANGER - SILAS MASON CO., INC.
IOWA ARMY AMMUNITION PLANT

REPORT OF TEST RESULTS FOR STRENGTH OF STEEL STRAPPING
AND STRAPPING SEAL JOINTS

Sealer/Crimper:

Serial # 29291 Pressure 90 psig. Size: 1-1/4" 3/4"

Test Type:

- | | | | |
|---------------------------------------------------------------------|--------------|--------------------------------------------|---------------------------------|
| <input type="checkbox"/> New Strap | P.O. # _____ | <input type="checkbox"/> Accept | <input type="checkbox"/> Reject |
| <input type="checkbox"/> New Seals | P.O. # _____ | <input type="checkbox"/> Accept | <input type="checkbox"/> Reject |
| <input type="checkbox"/> Strapper/Sealer Repair Verification | | <input type="checkbox"/> Accept | <input type="checkbox"/> Reject |
| <input type="checkbox"/> Strapper/Sealer Qualification | | <input type="checkbox"/> Accept | <input type="checkbox"/> Reject |
| <input checked="" type="checkbox"/> Strapper/Sealer Recertification | | <input checked="" type="checkbox"/> Accept | <input type="checkbox"/> Reject |

Strap Tension Results

Sealed Joint Results

TEST SAMPLE NUMBER	THICKNESS (INCHES)	STRAP WIDTH (INCHES)	ELONGATION (INCHES)	BREAKING STRENGTH (POUNDS)	JOINT EFFICIENCY (POUNDS)
# 1	.034	.752	.500	3500	2400
# 2	.032	.754	.500	3400	2138
# 3	.033	.754	.468	3500	2200

Sampled By: Gillette # NA NAME & BADGE Date: 11-20-95 Location: 3-01

Tested By: D. Mohr # 15121 NAME & BADGE Date: 11-20-95 Location: 1-84

Due for Next Testing 12-20-95 at Level I II III

Machine Tested On: Satec Other

Machine Setting: 12 K Medium 3.0 Pot Speed

Calibration Void Date: 12-13-95

Remarks From Line 3-01 F/120MM Hotb Chg
Moved From 800-192 To Line 3-01

MASON & HANGER - SILAS MASON CO., INC.
IOWA ARMY AMMUNITION PLANT

REPORT OF TEST RESULTS FOR STRENGTH OF STEEL STRAPPING
AND STRAPPING SEAL JOINTS

Sealer/Crimper:

Serial # 29291 Pressure 80 psig. Size: 1-1/4" 3/4"

Test Type:

- | | | | |
|---------------------------------------------------------------------|--------------|--------------------------------------------|---------------------------------|
| <input type="checkbox"/> New Strap | P.O. # _____ | <input type="checkbox"/> Accept | <input type="checkbox"/> Reject |
| <input type="checkbox"/> New Seals | P.O. # _____ | <input type="checkbox"/> Accept | <input type="checkbox"/> Reject |
| <input type="checkbox"/> Strapper/Sealer Repair Verification | | <input type="checkbox"/> Accept | <input type="checkbox"/> Reject |
| <input type="checkbox"/> Strapper/Sealer Qualification | | <input type="checkbox"/> Accept | <input type="checkbox"/> Reject |
| <input checked="" type="checkbox"/> Strapper/Sealer Recertification | | <input checked="" type="checkbox"/> Accept | <input type="checkbox"/> Reject |

Strap Tension Results

Sealed Joint Results

TEST SAMPLE NUMBER	THICKNESS (INCHES)	STRAP WIDTH (INCHES)	ELONGATION (INCHES)	BREAKING STRENGTH (POUNDS)	JOINT EFFICIENCY (POUNDS)
# 1	.036	.753	.531	3500	2500
# 2	.036	.752	.531	3500	3000
# 3	.035	.752	.500	3500	3400

Sampled By: Gillette #9434 Date: 10-24-95 Location: 3-05-1
NAME & BADGE

Tested By: D. Mohr #15121 Date: 10-24-95 Location: 1-84
NAME & BADGE

Due for Next Testing 11-23-95 at Level I II III

Machine Tested On: Satec Other

Machine Setting: 12 K Medium 3.0 Pot Speed

Calibration Void Date: 12-13-95

Remarks Loc. 3-05-01 F/4046

MASON & HANGER - SILAS MASON CO., INC.
IOWA ARMY AMMUNITION PLANT

REPORT OF TEST RESULTS FOR STRENGTH OF STEEL STRAPPING
AND STRAPPING SEAL JOINTS

Sealer/Crimper:

Serial # 1429 Pressure 100 psig. Size: 1-1/4" 3/4"

Test Type:

- | | | | |
|-------------------------------------------------------------------|--------------|--------------------------------------------|---------------------------------|
| <input type="checkbox"/> New Strap | P.O. # _____ | <input type="checkbox"/> Accept | <input type="checkbox"/> Reject |
| <input type="checkbox"/> New Seals | P.O. # _____ | <input type="checkbox"/> Accept | <input type="checkbox"/> Reject |
| <input type="checkbox"/> Strapper/Sealer Repair Verification | | <input type="checkbox"/> Accept | <input type="checkbox"/> Reject |
| <input checked="" type="checkbox"/> Strapper/Sealer Qualification | | <input checked="" type="checkbox"/> Accept | <input type="checkbox"/> Reject |
| <input type="checkbox"/> Strapper/Sealer Recertification | | <input type="checkbox"/> Accept | <input type="checkbox"/> Reject |

Strap Tension Results

TEST SAMPLE NUMBER	THICKNESS (INCHES)	STRAP WIDTH (INCHES)	ELONGATION (INCHES)	BREAKING STRENGTH (POUNDS)
# 1	.039	1.254	.593	6100
# 2	.039	1.253	.593	6100
# 3	.037	1.252	.593	6100
# 4	.038	1.253	.593	6100
# 5	.039	1.253	.625	6100
# 6	.039	1.253	.625	6000

Sealed Joint Results

JOINT EFFICIENCY (POUNDS)
4100
4300
4400
4500
4100
4400

Sampled By: C. Carpenter #10728 Date: 3-12-96 Location: 3-01
NAME & BADGE

Tested By: D. Mohr #15121 Date: 3-12-96 Location: 1-84
NAME & BADGE

Due for Next Testing 3-19-96 at Level I II III

Machine Tested On: Satec Other

Machine Setting: 12 K Medium 3.0 Pot Speed

Calibration Void Date: 4-23-96

Remarks From 1-01 MW Shop To Line 3-01 F/Qual Test F/M913
Used 1/4in Stanley Clips For This Test.

MASON & HANGER - SILAS MASON CO., INC.
IOWA ARMY AMMUNITION PLANT

REPORT OF TEST RESULTS FOR STRENGTH OF STEEL STRAPPING
AND STRAPPING SEAL JOINTS

Sealer/Crimper:

Serial # 1429 Pressure 90 psig. Size: 1-1/4" 3/4"

Test Type:

- | | | | |
|-------------------------------------------------------------------------|--------------|---------------------------------|---------------------------------|
| <input type="checkbox"/> New Strap | P.O. # _____ | <input type="checkbox"/> Accept | <input type="checkbox"/> Reject |
| <input type="checkbox"/> New Seals | P.O. # _____ | <input type="checkbox"/> Accept | <input type="checkbox"/> Reject |
| <input checked="" type="checkbox"/> Strapper/Sealer Repair Verification | | <input type="checkbox"/> Accept | <input type="checkbox"/> Reject |
| <input type="checkbox"/> Strapper/Sealer Qualification | | <input type="checkbox"/> Accept | <input type="checkbox"/> Reject |
| <input type="checkbox"/> Strapper/Sealer Recertification | | <input type="checkbox"/> Accept | <input type="checkbox"/> Reject |

Strap Tension Results

Sealed Joint Results

TEST SAMPLE NUMBER	THICKNESS (INCHES)	STRAP WIDTH (INCHES)	ELONGATION (INCHES)	BREAKING STRENGTH (POUNDS)	JOINT EFFICIENCY (POUNDS)
1					4900
2					5100
3					4900
4					4900
5					4700
6					4600

Sampled By: Joe M. 20319 Date: 10-11-94 Location: MW SHIP
NAME & BADGE

Tested By: Del Smith 14821 Date: 10-12-94 Location: 1-84
NAME & BADGE

Due for Next Testing 11-12 at Level I II III IV

Machine Tested On: Satec Other

Machine Setting: 12 K Medium 3.0 Pot Speed

Calibration Void Date: 11-17-94

Remarks Sealer has been repaired & successfully tested
Do not use until qualification test is accepted

MASON & HANGER - SILAS MASON CO., INC.
IOWA ARMY AMMUNITION PLANT

REPORT OF TEST RESULTS FOR STRENGTH OF STEEL STRAPPING
AND STRAPPING SEAL JOINTS

Sealer/Crimper:

Serial # 1429 Pressure 90 psig. Size: 1-1/4" 3/4"

Test Type:

- | | | | |
|---------------------------------------------------------------------|--------------|--------------------------------------------|---------------------------------|
| <input type="checkbox"/> New Strap | P.O. # _____ | <input type="checkbox"/> Accept | <input type="checkbox"/> Reject |
| <input type="checkbox"/> New Seals | P.O. # _____ | <input type="checkbox"/> Accept | <input type="checkbox"/> Reject |
| <input type="checkbox"/> Strapper/Sealer Repair Verification | | <input type="checkbox"/> Accept | <input type="checkbox"/> Reject |
| <input type="checkbox"/> Strapper/Sealer Qualification | | <input type="checkbox"/> Accept | <input type="checkbox"/> Reject |
| <input checked="" type="checkbox"/> Strapper/Sealer Recertification | | <input checked="" type="checkbox"/> Accept | <input type="checkbox"/> Reject |

Strap Tension Results

Sealed Joint Results

TEST SAMPLE NUMBER	THICKNESS (INCHES)	STRAP WIDTH (INCHES)	ELONGATION (INCHES)	BREAKING STRENGTH (POUNDS)	JOINT EFFICIENCY (POUNDS)
1	.033	1.251	.531	5800	4600
2	.034	1.251	.500	6100	4600
3	.033	1.252	500	6100	4600

Sampled By: Durbin NAME & BADGE Date: 9-7-94 Location: 2-01

Tested By: Del Smith NAME & BADGE 14801 Date: 9-7-94 Location: 1-84

Due for Next Testing 10-06-94 at Level I II III

Machine Tested On: Satec Other

Machine Setting: 12 K Medium 3.0 Pot Speed

Calibration Void Date: 11-17-94

Remarks _____

_____ MP31 120mm

MASON & HANGER - SILAS MASON CO., INC.
IOWA ARMY AMMUNITION PLANT

REPORT OF TEST RESULTS FOR STRENGTH OF STEEL STRAPPING
AND STRAPPING SEAL JOINTS

Sealer/Crimper:

Serial # 1429 Pressure 90 psig. Size: 1-1/4" 3/4"

Test Type:

- | | | | |
|---------------------------------------------------------------------|--------------|--------------------------------------------|---------------------------------|
| <input type="checkbox"/> New Strap | P.O. # _____ | <input type="checkbox"/> Accept | <input type="checkbox"/> Reject |
| <input type="checkbox"/> New Seals | P.O. # _____ | <input type="checkbox"/> Accept | <input type="checkbox"/> Reject |
| <input type="checkbox"/> Strapper/Sealer Repair Verification | | <input type="checkbox"/> Accept | <input type="checkbox"/> Reject |
| <input type="checkbox"/> Strapper/Sealer Qualification | | <input type="checkbox"/> Accept | <input type="checkbox"/> Reject |
| <input checked="" type="checkbox"/> Strapper/Sealer Recertification | | <input checked="" type="checkbox"/> Accept | <input type="checkbox"/> Reject |

Strap Tension Results

Sealed Joint Results

TEST SAMPLE NUMBER	THICKNESS (INCHES)	STRAP WIDTH (INCHES)	ELONGATION (INCHES)	BREAKING STRENGTH (POUNDS)	JOINT EFFICIENCY (POUNDS)
1.	.637	1.250	.593	6600	5000
2.	.037	1.251	.531	6600	5000
3.	037	1.251	593	6500	5000

Sampled By: Durbin 20754 NAME & BADGE Date: 8-10-94 Location: 2-01

Tested By: Dalbert Smith 14801 NAME & BADGE Date: 8-10-94 Location: 1-84

Due for Next Testing 9-8-94 at Level I II III

Machine Tested On: Satec Other

Machine Setting: 12 K Medium 3.0 Pot Speed

Calibration Void Date: 11-07-94

Remarks _____

M 830 A 1 120mm

MASON & HANGER - SILAS MASON CO., INC.
IOWA ARMY AMMUNITION PLANT

REPORT OF TEST RESULTS FOR STRENGTH OF STEEL STRAPPING
AND STRAPPING SEAL JOINTS

Sealer/Crimper:

Serial # 1429 Pressure 90 psig. Size: 1-1/4" 3/4"

Test Type:

- | | | | |
|---------------------------------------------------------------------|--------------|--------------------------------------------|---------------------------------|
| <input type="checkbox"/> New Strap | P.O. # _____ | <input type="checkbox"/> Accept | <input type="checkbox"/> Reject |
| <input type="checkbox"/> New Seals | P.O. # _____ | <input type="checkbox"/> Accept | <input type="checkbox"/> Reject |
| <input type="checkbox"/> Strapper/Sealer Repair Verification | | <input type="checkbox"/> Accept | <input type="checkbox"/> Reject |
| <input type="checkbox"/> Strapper/Sealer Qualification | | <input type="checkbox"/> Accept | <input type="checkbox"/> Reject |
| <input checked="" type="checkbox"/> Strapper/Sealer Recertification | | <input checked="" type="checkbox"/> Accept | <input type="checkbox"/> Reject |

Strap Tension Results

Sealed Joint Results

TEST SAMPLE NUMBER	THICKNESS (INCHES)	STRAP WIDTH (INCHES)	ELONGATION (INCHES)	BREAKING STRENGTH (POUNDS)	JOINT EFFICIENCY (POUNDS)
1	.038	1.251	.531	6300	5000
2	.038	1.250	.593	6300	5000
3	.038	1.250	.593	6300	5100

Sampled By: Durbin 20754 Date: 7-12-94 Location: 2-01
NAME & BADGE

Tested By: Del Smith 14801 Date: 7-13-94 Location: 1-84
NAME & BADGE

Due for Next Testing 08-11-94 at Level I II III

Machine Tested On: Satec Other

Machine Setting: 12 K Medium 3.0 Pot Speed

Calibration Void Date: 11-17-94

Remarks _____

_____ 120 11 831 11

ASTM DESIGNATION: B117-90

**STANDARD TEST METHOD OF
SALT SPRAY (FOG) TESTING**



Designation: B 117 - 90

AMERICAN SOCIETY FOR TESTING AND MATERIALS
1916 Race St., Philadelphia, Pa. 19103
Reprinted from the Annual Book of ASTM Standards, Copyright ASTM
If not listed in the current combined index, will appear in the next edition.

Standard Test Method of Salt Spray (Fog) Testing¹

This standard is issued under the fixed designation B 117; the number immediately following the designation indicates the year of original adoption or, in the case of revision, the year of last revision. A number in parentheses indicates the year of last reapproval. A superscript epsilon (ϵ) indicates an editorial change since the last revision or reapproval.

This standard has been approved for use by agencies of the Department of Defense to replace Method 811.1 of Federal Test Method Standard No. 151b. Consult the DoD Index of Specifications and Standards for the specific year of issue that has been adopted by the Department of Defense.

1. Scope

1.1 This test method sets forth the conditions required in salt spray (fog) testing for specification purposes. Suitable apparatus which may be used to obtain these conditions is described in Appendix X1. The method does *not* prescribe the type of test specimen or exposure periods to be used for a specific product, nor the interpretation to be given to the results. It should be noted that there is seldom a direct relation between salt spray (fog) resistance and resistance to corrosion in other media, because the chemistry of the reactions, including the formation of films and their protective value, frequently varies greatly with the precise conditions encountered. Comments on the use of the test in research will be found in Appendix X2. For evaluation of corrosive conditions, see Appendix X3.

NOTE 1—This method is applicable to salt spray (fog) testing of ferrous and non-ferrous metals, and is also used to test inorganic and organic coatings, etc., especially where such tests are the basis for material or product specifications.

1.2 The values stated in SI units are to be regarded as standard. The inch-pound units in parentheses are provided for information.

1.3 *This standard may involve hazardous materials, operations, and equipment. This standard does not purport to address all of the safety problems associated with its use. It is the responsibility of the user of this standard to establish appropriate safety and health practices and determine the applicability of regulatory limitations prior to use.*

2. Referenced Documents

2.1 ASTM Standards:

- B 287 Method of Acetic Acid-Salt Spray (Fog) Testing²
- B 368 Method for Copper-Accelerated Acetic Acid-Salt Spray (Fog) Testing (CASS Test)³

¹ This test method is under the jurisdiction of ASTM Committee G-1 on Corrosion of Metals, and is the direct responsibility of Subcommittee G01.05 on Laboratory Corrosion Tests.

Current edition approved March 30, 1990. Published May 1990. Originally published as B 117 - 39 T. Last previous edition B 117 - 85⁴.

² Discontinued—See 1987 Annual Book of ASTM Standards, Vols 02.05 and 03.02.

³ Annual Book of ASTM Standards, Vol 02.05.

- D 609 Methods for Preparation of Steel Panels for Testing Paint, Varnish, Lacquer, and Related Products⁴
- D 1193 Specification for Reagent Water⁵
- D 1654 Method for Evaluation of Painted or Coated Specimens Subjected to Corrosive Environments⁴
- E 70 Test Method for pH of Aqueous Solutions with the Glass Electrode⁶

3. Apparatus

3.1 The apparatus required for salt spray (fog) testing consists of a fog chamber, a salt solution reservoir, a supply of suitably conditioned compressed air, one or more atomizing nozzles, specimen supports, provision for heating the chamber, and necessary means of control. The size and detailed construction of the apparatus are optional, provided the conditions obtained meet the requirements of this method.

3.2 Drops of solution which accumulate on the ceiling or cover of the chamber shall not be permitted to fall on the specimens being tested.

3.3 Drops of solution which fall from the specimens shall not be returned to the solution reservoir for respraying.

3.4 Material of construction shall be such that it will not affect the corrosiveness of the fog.

4. Test Specimens

4.1 The type and number of test specimens to be used, as well as the criteria for the evaluation of the test results, shall be defined in the specifications covering the material or product being tested or shall be mutually agreed upon by the purchaser and the seller.

5. Preparation of Test Specimens

5.1 Metallic and metallic-coated specimens shall be suitably cleaned. The cleaning method shall be optional depending on the nature of the surface and the contaminants, except that it shall not include the use of abrasives other than a paste of pure magnesium oxide nor of solvents which are corrosive or will deposit either corrosive or protective films. The use of a nitric acid solution for the chemical cleaning, or passivation, of stainless steel specimens is permissible when agreed upon by the purchaser and the seller. Care shall be taken that specimens are not recontaminated after cleaning by excessive or careless handling.

⁴ Annual Book of ASTM Standards, Vol 06.01.

⁵ Annual Book of ASTM Standards, Vol 11.01.

⁶ Annual Book of ASTM Standards, Vol 13.05.



B 117

5.2 Specimens for evaluation of paints and other organic coatings shall be prepared in accordance with applicable specification(s) for the material(s) being tested, or as agreed upon by the purchaser and supplier. Otherwise, the test specimens shall consist of steel meeting the requirements of Methods D 609 and shall be cleaned and prepared for coating in accordance with applicable procedure of Methods D 609.

5.3 Specimens coated with paints or nonmetallic coatings shall not be cleaned or handled excessively prior to test.

5.4 Whenever it is desired to determine the development of corrosion from an abraded area in the paint or organic coating, a scratch or scribed line shall be made through the coating with a sharp instrument so as to expose the underlying metal before testing. The conditions of making the scratch shall be as defined in Method D 1654, unless otherwise agreed upon between the purchaser and seller.

5.5 Unless otherwise specified, the cut edges of plated, coated, or duplex materials and areas containing identification marks or in contact with the racks or supports shall be protected with a suitable coating stable under the conditions of the test, such as ceresin wax.

NOTE 2—Should it be desirable to cut test specimens from parts or from preplated, painted, or otherwise coated steel sheet, the cut edges shall be protected by coating them with paint, wax, tape, or other effective media so that the development of a galvanic effect between such edges and the adjacent plated or otherwise coated metal surfaces, is prevented.

6. Position of Specimens During Test

6.1 The position of the specimens in the salt spray chamber during the test shall be such that the following conditions are met:

6.1.1 Unless otherwise specified, the specimens shall be supported or suspended between 15 and 30° from the vertical and preferably parallel to the principal direction of horizontal flow of fog through the chamber, based upon the dominant surface being tested.

6.1.2 The specimens shall not contact each other or any metallic material or any material capable of acting as a wick.

6.1.3 Each specimen shall be so placed as to permit free settling of fog on all specimens.

6.1.4 Salt solution from one specimen shall not drip on any other specimen.

NOTE 3—Suitable materials for the construction or coating of racks and supports are glass, rubber, plastic, or suitably coated wood. Bare metal shall not be used. Specimens shall preferably be supported from the bottom or the side. Slotted wooden strips are suitable for the support of flat panels. Suspension from glass hooks or waxed string may be used as long as the specified position of the specimens is obtained, if necessary by means of secondary support at the bottom of the specimens.

7. Salt Solution

7.1 The salt solution shall be prepared by dissolving 5 ± 1 parts by weight of sodium chloride in 95 parts of water conforming to Type IV water in Specification D 1193. The salt used shall be sodium chloride substantially free of nickel and copper and containing on the dry basis not more than 0.1 % of sodium iodide and not more than 0.3 % of total

impurities. Some salts contain additives that may act as corrosion inhibitors; careful attention should be given to the chemical content of the salt. Upon agreement between purchaser and seller, analysis may be required and limits established for elements or compounds not specified in the chemical composition given above.

7.2 The pH of the salt solution shall be such that when atomized at 35°C (95°F) the collected solution will be in the pH range of 6.5 to 7.2 (Note 4). Before the solution is atomized it shall be free of suspended solids (Note 5). The pH measurement shall be made electrometrically at 25°C (77°F) using a glass electrode with a saturated potassium chloride bridge in accordance with Method E 70, or colorimetrically using bromothymol blue as indicator, or short range pH paper which reads in 0.2 or 0.3 of a pH unit (Note 6).

NOTE 4—Temperature affects the pH of a salt solution prepared from water saturated with carbon dioxide at room temperature and pH adjustment may be made by the following three methods:

(1) When the pH of a salt solution is adjusted at room temperature, and atomized at 35°C (95°F), the pH of the collected solution will be higher than the original solution due to the loss of carbon dioxide at the higher temperature. When the pH of the salt solution is adjusted at room temperature, it is therefore necessary to adjust it below 6.5 so the collected solution after atomizing at 35°C (95°F) will meet the pH limits of 6.5 to 7.2. Take about a 50-mL sample of the salt solution as prepared at room temperature, boil gently for 30 s, cool, and determine the pH. When the pH of the salt solution is adjusted to 6.5 to 7.2 by this procedure, the pH of the atomized and collected solution at 35°C (95°F) will come within this range.

(2) Heating the salt solution to boiling and cooling to 95°F for maintaining it at 95°F for approximately 48 h before adjusting the pH produces a solution the pH of which does not materially change when atomized at 35°C (95°F).

(3) Heating the water from which the salt solution is prepared to 35°C (95°F) or above, to expel carbon dioxide, and adjusting the pH of the salt solution within the limits of 6.5 to 7.2 produces a solution the pH of which does not materially change when atomized at 35°C (95°F).

NOTE 5—The freshly prepared salt solution may be filtered or decanted before it is placed in the reservoir, or the end of the tube leading from the solution to the atomizer may be covered with a double layer of cheesecloth to prevent plugging of the nozzle.

NOTE 6—The pH can be adjusted by additions of dilute cp hydrochloric acid or cp sodium hydroxide solutions.

8. Air Supply

8.1 The compressed air supply to the nozzle or nozzles for atomizing the salt solution shall be free of oil and dirt (Note 7) and maintained between 69 and 172 kN/m² (10 and 25 psi) (Note 8).

NOTE 7—The air supply may be freed from oil and dirt by passing it through a water scrubber or at least 610 mm (2 ft) of suitable cleaning material such as sheep's wool, excelsior, slag wool, or activated alumina.

NOTE 8—Atomizing nozzles may have a "critical pressure" at which an abnormal increase in the corrosiveness of the salt fog occurs. If the "critical pressure" of a nozzle has not been established with certainty, control of fluctuation in the air pressure within plus or minus 0.7 kN/m² (0.1 psi), by installation of a suitable pressure regulator valve¹ mini-

¹ Registered U. S. Patent Office.

² The Nullmatic pressure regulator (or equivalent) manufactured by Moore Products Co., H and Lycoming Sts., Philadelphia, PA 19124, is suitable for this purpose.

 B 117

mizes the possibility that the nozzle will be operated at its "critical pressure."⁹

9. Conditions in the Salt Spray Chamber

9.1 Temperature—The exposure zone of the salt spray chamber shall be maintained at $35 \pm 1.1 - 1.7^\circ\text{C}$ ($95 \pm 2 - 3^\circ\text{F}$). The temperature within the exposure zone of the closed cabinet shall be recorded at least twice a day at least 7 h apart (except on Saturdays, Sundays, and holidays when the salt spray test is not interrupted for exposing, rearranging, or removing test specimens or to check and replenish the solution in the reservoir).

NOTE 9—A suitable method to record the temperature is by a continuous recording device or by a thermometer which can be read from outside the closed cabinet. The recorded temperature must be obtained with the salt spray chamber to avoid a false low reading because of wet-bulb effect when the chamber is open.

9.2 Atomization and Quantity of Fog—At least two clean fog collectors shall be so placed within the exposure zone that no drops of solution from the test specimens or any other source shall be collected. The collectors shall be placed in the proximity of the test specimens, one nearest to any nozzle and the other farthest from all nozzles. The fog shall be such that for each 80 cm^2 of horizontal collecting area there will be collected in each collector from 1.0 to 2.0 mL of solution per hour based on an average run of at least 16 h (Note 10). The sodium chloride concentration of the collected solution shall be 5 ± 1 weight % (Note 11). The pH of the collected solution shall be 6.5 to 7.2. The pH measurement shall be made electrometrically or colorimetrically, using bromothymol blue as the indicator.

NOTE 10—Suitable collecting devices are glass funnels with the stems inserted through stoppers into graduated cylinders, or crystallizing dishes. Funnels and dishes with a diameter of 10 cm have an area of about 80 cm^2 .

NOTE 11—A solution having a specific gravity of 1.0255 to 1.0400 at 25°C (77°F) will meet the concentration requirement. The concentration may also be determined as follows: Dilute 5 mL of the collected solution to 100 mL with distilled water and mix thoroughly; pipet a 10-mL aliquot into an evaporating dish or casserole; add 40 mL of distilled water and 1 mL of 1 % potassium chromate solution (chloride-free) and titrate with 0.1 N silver nitrate solution to the first appearance of a permanent red coloration. A solution that requires between 3.4 and 5.1 mL of 0.1 N silver nitrate solution will meet the concentration requirements.

9.3 The nozzle or nozzles shall be so directed or baffled that none of the spray can impinge directly on the test specimens.

10. Continuity of Test

10.1 Unless otherwise specified in the specifications covering the material or product being tested, the test shall be continuous for the duration of the entire test period. Continuous operation implies that the chamber be closed and the spray operating continuously except for the short daily

⁹ It has been observed that periodic fluctuations in air pressure of $\pm 3.4\text{ kN/m}^2$ (0.3 psi) resulted in about a twofold increase in the corrosivity of the fog from a nozzle which was being operated at an average pressure of 110 kN/m^2 (16 psi). Controlling the fluctuations within $\pm 0.7\text{ kN/m}^2$ (0.1 psi), however, avoided any increase in the corrosivity of the salt fog. See Deroy, V. M. and Cavanagh, W. R., "Apparatus and Factors in Salt Fog Testing," *Proceedings, ASTM*, Vol 48, 1948, p. 133.

interruptions necessary to inspect, rearrange, or remove test specimens; to check and replenish the solution in the reservoir, and to make necessary recordings as described in Section 9. Operations shall be so scheduled that these interruptions are held to a minimum.

11. Period of Test

11.1 The period of test shall be as designated by the specifications covering the material or product being tested or as mutually agreed upon between the purchaser and the seller.

NOTE 12—Recommended exposure periods are to be as agreed upon by the purchaser and seller, but exposure periods of multiples of 24 h are suggested.

12. Cleaning of Tested Specimens

12.1 Unless otherwise specified in the specifications covering the material or product being tested, specimens shall be treated as follows at the end of the test:

12.1.1 The specimens shall be carefully removed

12.2 Specimens may be gently washed or dipped in clean running water not warmer than 38°C (100°F) to remove salt deposits from their surface, and then immediately dried. Drying shall be accomplished with a stream of clean, compressed air.

13. Evaluation of Results

13.1 A careful and immediate examination shall be made for the extent of corrosion of the dry test specimens or for other failure as required by the specifications covering the material or product being tested or by agreement between the purchaser and the seller.

14. Records and Reports

14.1 The following information shall be recorded, unless otherwise prescribed in the specifications covering the material or product being tested:

14.1.1 Type of salt and water used in preparing the salt solution,

14.1.2 All readings of temperature within the exposure zone of the chamber,

14.1.3 Daily records of data obtained from each fog-collecting device including the following:

14.1.3.1 Volume of salt solution collected in millimetres per hour 80 cm^2 ,

14.1.3.2 Concentration or specific gravity at 35°C (95°F) of solution collected, and

14.1.3.3 pH of collected solution.

14.4 Type of specimen and its dimensions, or number or description of part,

14.5 Method of cleaning specimens before and after testing,

14.6 Method of supporting or suspending article in the salt spray chamber,

14.7 Description of protection used as required in 5.5,

14.8 Exposure period,

14.9 Interruptions in test, cause and length of time, and

14.10 Results of all inspections.

NOTE 13—If any of the atomized salt solution which has not contacted the test specimens is returned to the reservoir, it is advisable to record the concentration or specific gravity of this solution also.

15. Precision and Bias¹⁰

15.1 The reproducibility of results in the salt spray test is highly dependent on the type of specimens tested and the evaluation criteria selected as well as the control of the operating variables. In any testing program, sufficient replicates should be included to establish the variability of the results. Substantial variability is often observed when similar specimens are tested in different fog chambers even though

the testing conditions are nominally similar and within the ranges specified in this method.

15.2 The salt spray (fog) test is intended to reproduce the corrosion that occurs in atmospheres containing salt spray or splash. It has been widely observed, however, that rankings of different alloys or coating systems, or both, do not necessarily fall in the same order as atmospheric tests in marine or road salt splash environments. This test has been more useful in rating the relative resistance of a specific type of protective coating, for example, hot-dip zinc coatings on steel. Interpretation of the results of this method beyond this purpose must be verified by actual exposure tests.

¹⁰ Supporting data are available on loan from ASTM Headquarters. Request RR: G01-1003.

APPENDIXES

(Nonmandatory Information)

X1. CONSTRUCTION OF APPARATUS

X1.1 Cabinets

X1.1.1 Standard salt spray cabinets are available from several suppliers, but certain pertinent accessories are required before they will function according to this method and provide consistent control for duplication of results.

X1.1.2 The salt spray cabinet consists of the basic chamber, an air-saturator tower, a salt solution reservoir, atomizing nozzles, specimen supports, provisions for heating the chamber, and suitable controls for maintaining the desired temperature.

X1.1.3 Accessories such as a suitable adjustable baffle or central fog tower, automatic level control for the salt reservoir, and automatic level control for the air-saturator tower are pertinent parts of the apparatus.

X1.1.4 The cabinet should be of sufficient size to test adequately the desired number of parts without overcrowding. Small cabinets have been found difficult to control

and those of less than 0.43-m³ (15-ft³) capacity should be avoided.

X1.1.5 The chamber may be made of inert materials such as plastic, glass, or stone, but most preferably is constructed of metal and lined with impervious plastics, rubber, or epoxy-type materials or equivalent.

X1.2 Temperature Control

X1.2.1 The maintenance of temperature within the salt chamber can be accomplished by several methods. It is generally desirable to control the temperature of the surroundings of the salt spray chamber and to maintain it as stable as possible. This may be accomplished by placing the apparatus in a constant-temperature room, but may also be achieved by surrounding the basic chamber of a jacket containing water or air at a controlled temperature.

X1.2.2 The use of immersion heaters in an internal salt solution reservoir or of heaters within the chamber is detrimental where heat losses are appreciable, because of solution evaporation and radiant heat on the specimens.

X1.2.3 All piping which contacts the salt solution or spray should be of inert materials such as plastic. Vent piping should be of sufficient size so that a minimum of back pressure exists and should be installed so that no solution is trapped. The exposed end of the vent pipe should be shielded from extreme air currents that may cause fluctuation of pressure or vacuum in the cabinet.

X1.3 Spray Nozzles

X1.3.1 Satisfactory nozzles may be made of hard rubber, plastic, or other inert materials. The most commonly used type is made of plastic. Nozzles calibrated for air consumption and solution atomized are available. The operating characteristics of a typical nozzle are given in Table X1.1.

X1.3.2 It can readily be seen that air consumption is relatively stable at the pressures normally used, but a marked reduction in solution sprayed occurs if the level of the solution is allowed to drop appreciably during the test. Thus,

TABLE X1.1 Operating Characteristics of Typical Spray Nozzle

Siphon Height, in.	Air Flow, L/min				Solution Consumption, mL/h			
	Air Pressure, psi				Air Pressure, psi			
	5	10	15	20	5	10	15	20
4	19	26.5	31.5	36	2100	3640	4584	5258
8	19	26.5	31.5	36	636	2760	3720	4320
12	19	26.5	31.5	36	0	1360	3000	3710
16	19	26.5	31.5	36	0	780	2124	2904

Siphon Height, cm	Air Flow, dm ³ /min				Solution Consumption, cm ³ /h			
	Air Pressure, kPa				Air Pressure, kPa			
	34	69	103	138	34	69	103	138
10	19	26.5	31.5	36	2100	3640	4584	5258
20	19	26.5	31.5	36	636	2760	3720	4320
30	19	26.5	31.5	36	0	1360	3000	3710
40	19	26.5	31.5	36	0	780	2124	2904

B 117

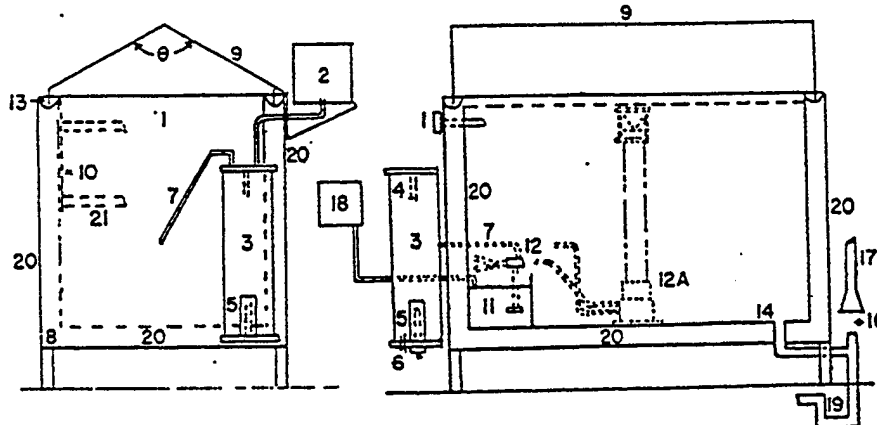

- 4—Angle of lid, 90 to 125°
- 1—Thermometer and thermostat for controlling heater (Item No. 8) in base
- 2—Automatic water leveling device
- 3—Humidifying tower
- 4—Automatic temperature regulator for controlling heater (Item No. 5)
- 5—Immersion heater, non-rusting
- 6—Air inlet, multiple openings
- 7—Air tube to spray nozzle
- 8—Strip heater in base
- 9—Hinged top, hydraulically operated, or counterbalanced
- 10—Brackets for rods supporting specimens, or test table
- 11—Internal reservoir
- 12—Spray nozzle above reservoir, suitably designed, located, and baffled
- 12A—Spray nozzle housed in dispersion tower located preferably in center of cabinet
- 13—Water Seal
- 14—Combination drain and exhaust. Exhaust at opposite side of test space from spray nozzle (Item 12), but preferably in combination with drain, waste trap, and forced draft waste pipe (Items 16, 17, and 19).
- 16—Complete separation between forced draft waste pipe (Item 17) and combination drain and exhaust (Items 14 and 19) to avoid undesirable suction or back pressure.
- 17—Forced draft waste pipe.
- 18—Automatic leveling device for reservoir
- 19—Waste trap
- 20—Air space or water jacket
- 21—Test table or rack, well below roof area

FIG. X1.1 Typical Salt Spray Cabinet

the level of the solution in the salt reservoir must be maintained automatically to ensure uniform fog delivery during the test.¹¹

X1.3.3 If the nozzle selected does not atomize the salt solution into uniform droplets, it will be necessary to direct the spray at a baffle or wall to pick up the larger drops and prevent them from impinging on the test specimens. Pending a complete understanding of air-pressure effects, etc., it is important that the nozzle selected shall produce the desired condition when operated at the air pressure selected. Nozzles are not necessarily located at one end, but may be placed in the center and can also be directed vertically up through a suitable tower.

X1.4 Air for Atomization

X1.4.1 The air used for atomization must be free of grease, oil, and dirt before use by passing through well-maintained filters. Room air may be compressed, heated, humidified, and washed in a water-sealed rotary pump, if the temperature of the water is suitably controlled. Otherwise

cleaned air may be introduced into the bottom of a tower filled with water, through a porous stone or multiple nozzles. The level of the water must be maintained automatically to ensure adequate humidification. A chamber operated according to this method and Appendix will have a relative humidity between 95 and 98 %. Since salt solutions from 2 to 6 % will give the same results (though for uniformity the limits are set at 4 to 6 %), it is preferable to saturate the air at temperatures well above the chamber temperature as insurance of a wet fog. Table X1.2 shows the temperatures, at different pressures, that are required to offset the cooling effect of expansion to atmospheric pressure.

X1.4.2 Experience has shown that most uniform spray chamber atmospheres are obtained by increasing the atom-

TABLE X1.2 Temperature and Pressure Requirements for Operation of Test at 95°F

Temperature, °F	Air Pressure, psi			
	12	14	16	18
	114	117	119	121
Temperature, °C	Air Pressure, kPa			
	83	96	110	124
	48	47	48	49

¹¹ A suitable device for maintaining the level of liquid in, either the saturator tower, or reservoir of test solution may be designed by a local engineering group, or may be purchased from manufacturers of test cabinets as an accessory.

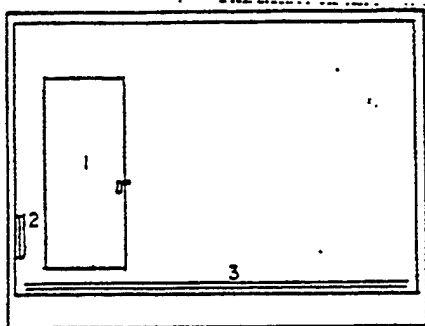
 B 117

NOTE—The controls are the same, in general as for the laboratory cabinet (Fig. X1.1), but are sized to care for the larger cube. The chamber has the following features:

- (1) Heavy insulation,
- (2) Refrigeration door with drip rail, or pressure door with drip rail, inward-sloping sill,
- (3) Low-temperature auxiliary heater, and
- (4) Duck boards on floor, with floor sloped to combination drain and air exhaust.

FIG. X1.2 Walk-in Chamber, 1.5 by 2.4 m (5 by 8 ft) and Upward in Over-all Size

izing air temperature sufficiently to offset heat losses, except those that can be replaced otherwise at very low-temperature gradients.

X1.5 Types of Construction

X1.5.1 A modern laboratory cabinet is shown in Fig. X1.1. Walk-in chambers are not usually constructed with a

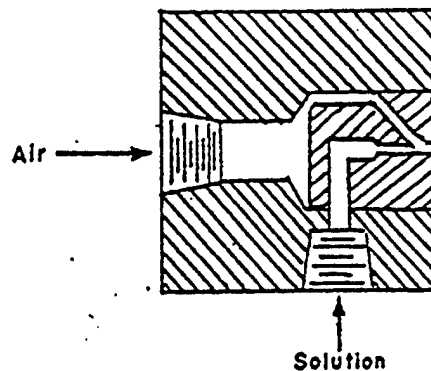

FIG. X1.3 Typical Spray Nozzle

sloping ceiling due to their size and location. Suitably located and directed spray nozzles avoid ceiling accumulation and drip. Nozzles may be located at the ceiling, or 0.91 m (3 ft) from the floor directed upward at 30 to 60° over a passageway. The number of nozzles depends on type and capacity and is related to the area of the test space. A 11 to 19-dm³ (3 to 5-gal) reservoir is required within the chamber, with the level controlled. The major features of a walk-in type cabinet, which differs significantly from the laboratory type, are illustrated in Fig. X1.2. Construction of a plastic nozzle, such as is furnished by several suppliers, is shown in Fig. X1.3.

X2. USE OF THE SALT SPRAY (FOG) TEST IN RESEARCH

X2.1 The detailed requirements of this method are primarily for quality acceptance and should not be construed as the optimum conditions for research studies. The test has been used to a considerable extent for the purpose of comparing different materials or finishes with an acceptable standard. The recent elimination of many cabinet variables and the improvement in controls have made the three ASTM Salt Spray Tests: Method B 117, B 287, and B 368, into useful tools for many industrial and military production and qualification programs.

X2.2 The test has been used to a considerable extent for the purpose of comparing different materials or finishes. It should be noted that there is seldom a direct relation between salt spray (fog) resistance and resistance to corrosion in other media, because the chemistry of the reactions, including the formation of films and their protective value, frequently varies greatly with the precise conditions encountered. Informed personnel are aware of the erratic composition of basic alloys, the possibility of wide variations in quality and thickness of plated items produced on the same racks at the same time, and the consequent need for a mathematical determination of the number of specimens required to constitute an adequate sample for test purposes. In this connection it is well to point out that Method B 117 is not applicable to the study or testing of decorative chromium

plate (nickel-chromium or copper-nickel-chromium) on steel or on zinc-base die castings or of cadmium plate on steel. For this purpose Methods B 287 and B 368 are available, which are also considered by some to be superior for comparison of chemically-treated aluminum (chromated, phosphated, or anodized), although final conclusions regarding the validity of test results related to service experience have not been reached. Method B 117 is considered to be most useful in estimating the relative behavior of closely related materials in marine atmospheres, since it simulates the basic conditions with some acceleration due to either wetness or temperature or both.

X2.3 When a test is used for research, it may prove advantageous to operate with a different solution composition or concentration or at a different temperature. In all cases, however, it is desirable to control the temperature and humidity in the manner specified, and to make certain that the composition of the settled fog and that of the solution in the reservoir are substantially the same. Where differences develop, it is necessary to control conditions so that the characteristics of the settled fog meet the specified requirements for the atmosphere.

X2.4 Material specifications should always be written in terms of the standard requirements of the appropriate salt spray method, thereby making it possible to test a variety of materials from different sources in the same equipment.

X3. EVALUATION OF CORROSIVE CONDITIONS

X3.1 General—This appendix covers test panels and procedures for evaluating the corrosive conditions within a salt spray cabinet. The procedure involves the exposure of steel test panels and the determination of their mass losses in a specified period of time. This may be done monthly or more frequently to insure consistent operation over time. It is also useful for correlating the corrosive conditions among different cabinets.

X3.2 Test Panels—The required test panels, 76 mm by 127 mm by 0.8 mm, are made from SAE 1010 commercial grade cold-rolled carbon steel (UNS G10080).

X3.3 Preparation of Panels Before Testing—Clean panels before testing by degreasing only, so that the surfaces are free of dirt, oil, or other foreign matter that could influence the test results. After cleaning, weigh each panel on an analytical balance to the nearest 1.0 mg and record the mass.

X3.4 Positioning of Test Panels—Place a minimum of two weighed panels in the cabinet, with the 127-mm length supported 30° from vertical. Place the panels in the prox-

imity of the condensate collectors. (see Section 6).

X3.5 Duration of Test—Expose panels to the salt fog for 48 to 168 h.

X3.6 Cleaning of Test Panels After Exposure—After removal of the panels from the cabinet, rinse each panel immediately with running tap water to remove salt, and rinse in reagent grade water (see Specification D 1193, Type IV). Chemically clean each panel for 10 min at 20–25°C in a fresh solution prepared as follows:

Mix 1000 mL of hydrochloric acid (Sp. Gr. 1.19) with 1000 mL reagent grade water (D 1193, Type IV) and add 10 grams of hexamethylene tetramine. After cleaning, rinse each panel with reagent grade water (Type IV) and dry (see 12.2).

X3.7 Determining Mass Loss—Immediately after drying, determine the mass loss by reweighing and subtracting panel mass after exposure from its original mass. The mass should not vary 20% from test to test.

X3.7.1 Data generated in the Interlaboratory Study using this method are available from ASTM as Research Report.

The American Society for Testing and Materials takes no position respecting the validity of any patent rights asserted in connection with any item mentioned in this standard. Users of this standard are expressly advised that determination of the validity of any such patent rights, and the risk of infringement of such rights, are entirely their own responsibility.

This standard is subject to revision at any time by the responsible technical committee and must be reviewed every five years and if not revised, either reapproved or withdrawn. Your comments are invited either for revision of this standard or for additional standards and should be addressed to ASTM Headquarters. Your comments will receive careful consideration at a meeting of the responsible technical committee, which you may attend. If you feel that your comments have not received a fair hearing you should make your views known to the ASTM Committee on Standards, 1916 Race St., Philadelphia, PA 19103.

ASTM DESIGNATION: D 3953-91

**STANDARD SPECIFICATION FOR
STRAPPING, FLAT STEEL AND SEALS**



Designation: D 3953 - 91

AMERICAN SOCIETY FOR TESTING AND MATERIALS
1916 Race St., Philadelphia, Pa. 19103
Reprinted from the Annual Book of ASTM Standards, Copyright ASTM
If not listed in the current cumulative index, it will appear in the next edition.

Standard Specification for Strapping, Flat Steel and Seals¹

This standard is issued under the fixed designation D 3953, the number immediately following the designation indicates the year of original adoption or, in the case of revision, the year of last revision. A number in parentheses indicates the year of last reapproval. A superscript epsilon (ϵ) indicates an editorial change since the last revision or reapproval.

1. Scope

1.1 This specification covers flat steel strapping and seals intended for use in closing, reinforcing, bundling articles for shipment, unitizing, palletizing, and bracing for carloading and truckloading.

1.2 This specification includes strapping and seals made from carbon steel and applies only to the types and sizes as cataloged by strapping suppliers to be a standard, commercially available product. It does not include "specialty"-type strapping as developed for special applications or strapping produced from alloy metals.

1.3 The values stated in inch-pound units are to be regarded as standard.

1.4 The following safety hazards caveat applies only to the test method portion, Sections 11, 12, and 13, of this specification: *This standard does not purport to address all of the safety problems, if any, associated with its use. It is the responsibility of the user of this standard to establish appropriate safety and health practices and determine the applicability of regulatory limitations prior to use.*

2. Referenced Documents

2.1 ASTM Standards:

- A 90 Test Method for Weight of Coating on Zinc-Coated (Galvanized) Iron or Steel Articles²
- A 109 Specification for Steel, Strip, Carbon, Cold-Rolled³
- A 239 Test Method for Locating the Thinnest Spot in a Zinc (Galvanized) Coating on Iron or Steel Articles by the Prece Test (Copper Sulfate Dip)²
- B 504 Method for Measurement of Thickness of Metallic Coatings by the Coulometric Method⁴
- D 996 Terminology of Packaging and Distribution Environments⁵
- D 3951 Practice for Commercial Packaging⁵
- D 4332 Practice for Conditioning Containers Package, or Package Components for Testing⁵
- 2.2 *Military Standard:*
- MIL-STD-105 Sampling Procedures and Tables for Inspection by Attributes⁶
- 2.3 *AAR General Rules 15*

¹ This specification is under the jurisdiction of ASTM Committee D-10 on Packaging and is the direct responsibility of Subcommittee D10.14 on Closure and Reinforcement.

Current edition approved Jan. 25, 1991. Published May 1991. Originally published as D 3953 - 83; last previous edition D 3953 - 87.¹¹

² Annual Book of ASTM Standards, Vol 01.06.

³ Annual Book of ASTM Standards, Vol 01.03.

⁴ Annual Book of ASTM Standards, Vol 02.05.

⁵ Annual Book of ASTM Standards, Vol 15.09.

⁶ Available from Standardization Documents Order Desk, Bldg. 4 Section D, 700 Robbins Ave., Philadelphia, PA 19111-5094, Attn: NPODS.

AAR Rule Governing the Loading of Commodities on Open Top Cars⁷

3. Terminology

3.1 General definitions for packaging and distribution environments are found in Terminology D 996.

4. Strapping Classifications

4.1 Strapping shall be of the following types, finish and sizes:

Type 1, Flat Strapping: Power Machine and Hand Application:

Regular-duty

Heavy-duty

Heavy-duty, high elongation

Type 2: Nail-On

4.1.1 *Strapping Finish, Lubricated or Dry* (see 8.3):

4.1.1.1 *Finish A—Organic (Pigmented or Unpigmented Paint)*

4.1.1.2 *Finish B—Galvanized (Hot Dipped or Electro-Deposit Galvanized)* (see 8.10):

Grade 1—Heavy Coating

Grade 2—Moderate Coating

Grade 3—Commercial Coating

4.1.1.3 *Finish C—Organic Painted Metallic Filled (Aluminum or Zinc)*

4.1.1.4 *Finish D—Uncoated*

4.1.2 *Strapping Sizes*—Strapping shall have the widths and thicknesses in accordance with sizes shown in Tables 1 and 2.

5. Seal Classifications

5.1 Seals shall be of the following classes, finishes, types, and styles:

5.1.1 *Seal Classes:*

R—Regular duty

H—Heavy duty

5.1.2 *Seal Finishes:*

Finish A—Organic (painted)

Finish B—Galvanized (hot dipped or electro-deposit galvanized)

Grade 1—Heavy coating

Grade 2—Moderate coating

Grade 3—Manufacturer's standard commercial practice

Finish C—Uncoated

5.1.3 *Seal Styles:*

1—Snap-on or open

⁷ AAR Rule Governing the Loading of Commodities on Open Top Cars, Section No. 1 General Rules—Rule 15, available from the Association of American Railroads, Mechanical Division 50 F St., NW, Washington, DC 20001.

D 3953

TABLE 1 Type 1 Regular-Duty Strapping Widths, Thickness, and Breaking Strengths

Width, in. (mm)	Thickness, in. (mm)							
	0.010 (0.25)	0.012 (0.30)	0.015 (0.38)	0.018 (0.46)	0.020 (0.51)	0.023 (0.58)	0.028 (0.71)	0.035 (0.89)
	Breaking Strength, min. lbf (N)							
3/8 (9.52)	300 (1335)	360 (1600)	450 (2000)	540 (2400)	600 (2670)	690 (3070)	920 (4090)	1150 (5115)
1/2 (12.70)	400 (1770)	480 (2135)	600 (2670)	720 (3200)	800 (3560)	1000 (4450)	1340 (6140)	2100 (9340)
5/8 (15.87)	500 (2225)	600 (2670)	750 (3335)	900 (4000)	1000 (4450)	1200 (5310)	1600 (7170)	2100 (9340)
1 (25.4)	600 (2670)	750 (3335)	900 (4000)	1000 (4450)	1200 (5310)	1600 (7170)	2100 (9340)	2100 (9340)

TABLE 2 Type 1 Heavy-Duty, Heavy-Duty/High Elongation Strapping Widths, Thickness, and Breaking Strengths

Width, in. (mm)	Thickness, in. (mm)										
	0.020 (0.51)	0.022 (0.56)	0.023 (0.58)	0.025 (0.64)	0.028 (0.71)	0.029 (0.75)	0.031 (0.79)	0.035 (0.89)	0.044 (1.12)	0.050 (1.27)	0.057 (1.45)
	Breaking Strength, min. lbf (N)										
3/8 (9.52)	1200 (5300)	1470 (6540)	1840 (8185)	2200 (9790)	2200 (9790)	2850 (12675)	2850 (12675)	2850 (12675)	4050 (18015)	4050 (18015)	7700 (34250)
1/2 (12.70)	1600 (7120)	2280 (10140)	2280 (10140)	2200 (9790)	2200 (9790)	2850 (12675)	2850 (12675)	2850 (12675)	4050 (18015)	4050 (18015)	7700 (34250)
5/8 (15.87)	2000 (8900)	2280 (10140)	2280 (10140)	2200 (9790)	2200 (9790)	2850 (12675)	2850 (12675)	2850 (12675)	4050 (18015)	4050 (18015)	7700 (34250)
1 (25.4)	2000 (8900)	2280 (10140)	2280 (10140)	2200 (9790)	2200 (9790)	2850 (12675)	2850 (12675)	2850 (12675)	4050 (18015)	4050 (18015)	7700 (34250)
1 1/4 (31.75)	3200 (14240)	3600 (16000)	3600 (16000)	3600 (16000)	3600 (16000)	4750 (21130)	4750 (21130)	4750 (21130)	6750 (30025)	6750 (30025)	7700 (34250)
2 (50.80)	4750 (21130)	4750 (21130)	4750 (21130)	4750 (21130)	4750 (21130)	4750 (21130)	4750 (21130)	4750 (21130)	6750 (30025)	6750 (30025)	7700 (34250)

^a Heavy-duty, or heavy-duty/high elongation.

TABLE 3 Number of Feet Per Pound (Metres per Kilogram) of Type 1 Strapping^a

Note:—Number of feet per pound (metres per kilogram) is based on nominal dimensions and will vary slightly with the width and thickness of the strapping within the tolerances as described in 8.2.

Width, in. (mm)	Thickness, in. (mm)														
	0.010 (0.25)	0.012 (0.311)	0.015 (0.38)	0.018 (0.46)	0.020 (0.51)	0.022 (0.56)	0.023 (0.58)	0.025 (0.64)	0.028 (0.71)	0.029 (0.75)	0.031 (0.79)	0.035 (0.89)	0.044 (1.12)	0.050 (1.27)	0.057 (1.45)
	Length per Unit Mass, ft/lb (m/kg), approximate														
3/8 (9.52)	78.5 (28.2)	65.4 (23.7)	52.4 (18.9)	43.6 (15.7)	39.3 (14.1)	34.1 (12.3)	34.1 (12.3)	34.1 (12.3)	34.1 (12.3)	34.1 (12.3)	34.1 (12.3)	34.1 (12.3)	34.1 (12.3)	34.1 (12.3)	34.1 (12.3)
1/2 (12.70)	50.9 (18.3)	49.1 (17.6)	39.3 (14.1)	32.7 (11.7)	29.4 (10.7)	25.6 (9.2)	25.6 (9.2)	25.6 (9.2)	25.6 (9.2)	25.6 (9.2)	25.6 (9.2)	25.6 (9.2)	25.6 (9.2)	25.6 (9.2)	25.6 (9.2)
5/8 (15.87)	47.1 (17.0)	39.3 (14.1)	31.4 (11.3)	26.2 (9.5)	23.6 (8.5)	20.5 (7.4)	20.5 (7.4)	20.5 (7.4)	20.5 (7.4)	20.5 (7.4)	20.5 (7.4)	20.5 (7.4)	20.5 (7.4)	20.5 (7.4)	20.5 (7.4)
1 (25.4)	31.6 (11.3)	26.4 (9.5)	21.1 (7.6)	17.6 (6.3)	17.8 (6.4)	17.1 (6.1)	15.7 (5.6)	14.0 (5.0)	13.5 (4.8)	12.7 (4.5)	11.2 (4.0)	10.1 (3.6)	9.5 (3.4)	8.5 (3.0)	7.5 (2.7)
1 1/4 (31.75)	11.8 (4.2)	11.8 (4.2)	11.8 (4.2)	11.8 (4.2)	11.8 (4.2)	11.8 (4.2)	9.4 (3.4)	9.4 (3.4)	9.4 (3.4)	9.4 (3.4)	9.4 (3.4)	8.1 (2.9)	7.6 (2.7)	6.6 (2.4)	5.3 (1.9)
2 (50.80)	4.7 (1.7)	4.7 (1.7)	4.7 (1.7)	4.7 (1.7)	4.7 (1.7)	4.7 (1.7)	4.7 (1.7)	4.7 (1.7)	4.7 (1.7)	4.7 (1.7)	4.7 (1.7)	4.7 (1.7)	4.7 (1.7)	4.7 (1.7)	4.7 (1.7)

^a Commercial tolerances apply.

- II—Thread-on or closed
- III—Push-type or overlap
- IV—Magazine-feed
- V—Intersectional or cross-tie

5.2 Seal Sizes—Seals shall have widths in accordance with strapping width shown in Tables 1 and 2.

6. Ordering Information

- 6.1 The inquiry and order shall indicate the following:
 - 6.1.1 Strapping type, duty, finish, grade, lubrication

(when applicable), dimension required, and quantity of each size (see Section 4).

6.1.2 Coil of strapping dimensions, weight and feet per pound, oscillated, ribbon wound, or cut-to-length (see Section 9, Tables 3 and 4, and Figs. 1 and 2).

6.1.3 Seals (see Section 5) class, finish, grade (when applicable), type, style, and quantity by width (or nomenclature).

6.1.4 Make or model of strapping equipment that the strapping and seals must work in, if applicable.

6.1.5 Title, designation, and date of this specification.

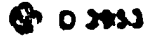

TYPICAL
RECOMMENDED
CRIMP TYPE JOINTS



TYPICAL
RECOMMENDED
NOTCH TYPE JOINTS

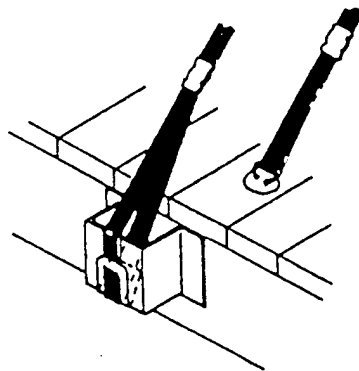

LOOP TYPE SECUREMENT, AS ILLUSTRATED,
REQUIRES ONLY ONE SEAL PROPERLY SEALED,
TO PROVIDE ACCEPTABLE JOINT EFFICIENCY.

FIG. 1 Recommended Seal Joints

6.1.6 For Department of Defense, indicate selection of preservation, packing, marking, and palletization, if applicable (see Section 16).

6.2 Sizes or physical properties, or both, other than those covered by this specification shall be as specified in the contract or order.

7. Materials and Manufacture

7.1 Materials shall be cold-rolled carbon steel of the quality normally used for this purpose in commercial practice, and the physical mechanical property requirements, as determined by tests, shall be within the allowable limits.

7.1.1 *Type 1 Regular-Duty Strapping*—Regular-duty

strapping in Table 1 shall be low-carbon cold-rolled steel (see 6.1.1).

7.1.2 *Type 1 Heavy-Duty Strapping*—Heavy-duty strapping in Table 2 shall be cold-rolled, high-carbon, or medium carbon high-manganese steel which has been fully heat-treated; for example, austenitized and quenched.

7.1.3 *Type 1 Heavy-Duty, High-Elongation Strapping*—Heavy-duty, high-elongation strapping in Table 2 shall be high-carbon steel which has been fully heat-treated; for example, austenitized and quenched to provide the elongations in 8.1.2.

7.1.4 *Type 2 Nail-On Strapping*—Unless otherwise specified, Type 2 nail-on strapping shall be strapping made from Type 1 regular-duty or Type 1 heavy-duty strapping, avail-

TABLE 4 Size of Coils and Package

Type Coil	Size of Strapping in (mm)	Inside Diameter, in. (mm) (Commercial Tolerance)	Outside Diameter max in (mm)	Coils Per Package max
Oscillated	3/8 by 0.010 (9.52 by 0.25) through	16 (406)	23 1/2 (597)	1
	3/8 by 0.035 (9.52 by 0.89)			
Ribbon	3/8 by 0.022 (9.52 by 0.56) through	16 (406)	27 (686)	2
	3/8 by 0.035 (9.52 by 0.89)			
	1 by 0.020 (25.4 by 0.75) through	16 (406)	27 (686)	1
	1 by 0.031 (25.4 by 0.79)			
	1 1/4 by 0.020 (31.75 by 0.51) through	16 (406)	27 (686)	1
	1 1/4 by 0.057 (31.75 by 1.45)			
2 by 0.014 (50.80 by 1.12) through	16 (406)	25 1/2 (657)	1	
2 by 0.050 (50.80 by 1.27)				

Duty and Heavy-Duty Strapping

8.1.1 *Breaking Strength*—The breaking strength of the strapping shall be as shown in Table 1 and Table 2 when tested as specified in 13.3.

8.1.2 *Elongation*—The elongation in 6 in. (152 mm) for Type 1 strapping, when tested as specified in 13.4, shall be as follows:

Regular-duty (see 7.1.1)	0.5 to 4.0%
Heavy-duty (see 7.1.2)	5.0 to 12%
Thickness less than 0.031 in. (0.79 mm)	6.5 to 12%
Thickness 0.031 in. (0.79 mm) and greater	9.0 to 16%
Heavy-duty high elongation (see 7.1.3)	
Thickness 0.035 in. (0.889 mm) and greater	9.0 to 16%

8.2 *Tolerances, Type 1 Strapping, Widths*—The widths of the strapping shall not vary from that shown in Tables 1 and 2 by more than ±0.005 in. (0.13 mm) for all cold-rolled strapping.

8.2.1 *Type 1 Strapping, Thickness*—The thickness of strapping sizes listed in Tables 1 and 2 shall not vary from nominal thickness by more than the following:

Cold-rolled strapping 0.031 in. (0.79 mm) or less in thickness	+0.002 in. (0.05 mm), -0.001 (0.03 mm).
Cold-rolled strapping greater than 0.031 in. (0.79 mm) in thickness up to 0.087 in. (2.21 mm)	±0.002 in. (0.05 mm).

8.3 *Lubrication*—Unless otherwise specified, Type 1 strapping shall have a coating of wax or wax-like lubricant applied to the surfaces that will render the strapping suitable for application with tension tools of the feed wheel (friction) type (see 4.1.2 and 6.1.4). The lubrication of the strapping is intended to facilitate the use of strapping tools in which the two bands of the strapping are held in contact with each other under pressure by frictional grips, and sliding of the faces of the strapping is necessary during the tensioning operation. Test in accordance with 13.9.

8.4 *Type 1 Strapping, Coils*—Each coil shall consist of one continuous piece of strapping. Coils with lengths of strapping welded together shall be considered as one-piece coil. Type 1 strapping shall have no more than two welded joints in any coil.

8.4.1 *Dimensional Requirements at the Weld*—The thickness at the weld shall be no more than one and one half the

able in sizes 3/8 in. (15.87 mm) in width or greater with punched nail holes. Hole diameters and hole spacing can vary depending upon strap size and duty, which shall be in accordance with manufacturer's standard practice. However, nail holes shall be spaced at intervals no more than 3 in. (76 mm) apart.

7.1.5 *Seals for Type 1 Strapping*—Unless otherwise specified, seals for Type 1 strapping shall be made of steel in accordance with the manufacturer's commercial practice.

8. Physical and Mechanical Properties

8.1 Breaking Strength and Elongation, Type 1 Regular-

Coil Weight:
90 lb (41 kg) to
110 lb (50 kg)

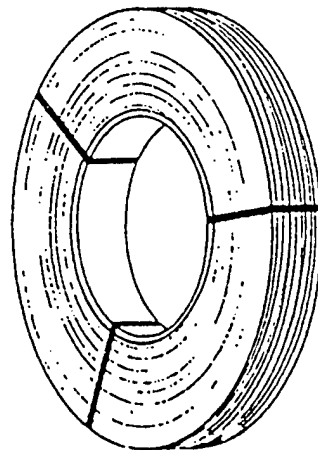

OSCILLATED WOUND
COIL.

FIG. 2 Oscillated Wound Coil

D 3953

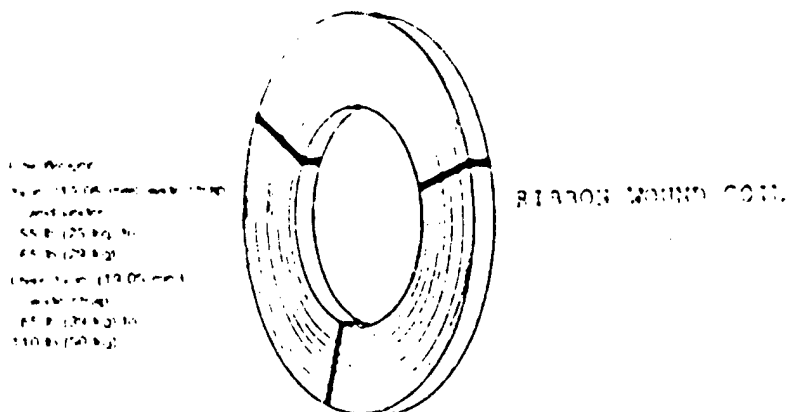

FIG. 3 Ribbon-wound Coil

thickness of the strap. The width of strapping at the weld shall be subject to the same dimensional requirements as the remainder of the strapping. Metal splattering or extruded points causing increased thickness are not permissible. Only machine welds shall be acceptable.

8.4.2 Weld Efficiency—Strength of manufacturer's process welded joints in coils of strapping shall have a joint efficiency of not less than 75% based on the breaking strength shown in Tables 1 and 2 when tested as specified in 13.6.

8.5 Identification Marking—Each coil of Type 1 heavy-duty, 1 1/2-in. (38.1 mm) by 0.029 in. (0.75 mm) in thickness and greater and 2-in. wide (50.8 mm) strapping shall be marked in accordance with the Association of American Railroads General Rule 15. The marking shall consist of the letters "AAR," the manufacturer's or distributor's name, or abbreviated name, or registered trademark, or symbol, or AAR code consisting of two digits. Marking shall be spaced not more than 5 ft (1.52 m) apart.

8.6 Type 2 Strapping:

8.6.1 Breaking Strength—The breaking strength for Type 2 strapping shall be the same as shown in Table 1 or 2 for the applicable strapping size and type, but shall be based on the cross-sectional metal area of the strapping taken across the hole. Breaking strength will be reduced proportionally in accordance with nail hole diameter.

8.6.2 Tolerances—The tolerances on width and thickness for Type 2 strapping shall be the same as for Type 1 strapping (see 8.2).

8.7 Seals, Type 1 Strapping—Seals intended for Type 1 strapping shall be made of steel to manufacturer's commercial practice. Seal lengths shall be adequate for a single-notch joint (one pair of cut notches), a double-notch joint (two pairs of cut notches), a double-crimp joint (two pairs of crimps), a triple-crimp joint (three pairs of crimps), or a quadruple-crimp joint (four pairs of crimps). Unless otherwise specified, seals shall be suitable in size or design to satisfy the requirements of 8.9.2 and 8.9.3.

8.7.1 Seal Width—Seal width shall be adequate to allow the seal to slip on the applicable strapping and shall be compatible with the sealing tool used to provide the required joint strength.

8.7.2 Seals, Regular- and Heavy-Duty—Seals shall be in

thickness and hardness suitable for use with regular- or heavy-duty strapping. Regular-duty seals shall be used with regular-duty strapping and heavy-duty seals with heavy-duty strapping.

8.8 Application of Seals:

8.8.1 Style I—Style I seals shall have one or both sides open so that the seal shall slip in the overlapping bands of strapping either during or after tensioning the strapping.

8.8.2 Style II—Style II seals shall have sides partially closed at the bottom of the seal so that this shall be breached with the overlapping bands of strapping before the tensioning tool is applied.

8.8.3 Style III—Style III seals shall have the sides completely closed by overlapping at the bottom of the seal so that prethreading with the overlapping of bands of strapping and prethreading of the bottom overlap under the seal can be accomplished. The seal shall permit the tensioning tool to tension the strapping as the tool butts against the seal.

8.8.4 Style IV—Style IV seals shall have sides opened to allow nesting and stacking of the seals for hand or power tools with magazine feed. Seals shall fit and form joints with the seal manufacturer's tool model as specified (see 6.1.4). Means provided on Style IV seals to facilitate stacking are acceptable.

NOTE 1—Style IV seals are commonly designed for use with the seal manufacturer's tool and are not adaptable for other manufacturer's tools.

8.8.5 Style V—Style V seals shall have one or both sides open so that the seal shall slip on the crossing bands of strapping either during or after tensioning of the straps.

8.9 Sealed Joints:

8.9.1 Fastening Flat Steel Strapping—The various methods of fastening flat steel strapping in use commercially are notched seal joints, crimped seal joints, and sealless joints made by die cutting or spot welding the overlapping ends of the strapping. These methods are acceptable provided that the joint made meets the efficiency requirements, as follows:

8.9.2 Notch Joints—Notch-type seal joints made with hand tools, power hand tools, or power strapping machines recommended by the supplier, shall be made on applicable strapping, without cracking and tearing of the seal metal. Notched seal joints are usually intended for use with

D 3953

TABLE 5 Mass Loss of Zinc Coating

Strapping Width		Minimum Mass Loss, mg/6 in. (152.4 mm) Section		
in.	(mm)	Grade 1	Grade 2	Grade 3
3/8	(9.52)	263	158	53
1/2	(12.70)	350	210	70
5/8	(15.87)	438	262	87
3/4	(19.05)	525	315	105
1	(25.40)	700	420	140
1 1/4	(31.75)	875	525	175
2	(50.8)	1400	840	280

lubricated (waxed) strapping. Notched seal joints when used with Type 1 regular-duty strapping, or Type 1 heavy-duty strapping must have a minimum joint strength of 75 % for double-notch joints and 45 % for single-notch joints. Joint strength is based on the minimum breaking strength of the applicable strapping size as shown in Tables 1 and 2 when tested as specified in 13.5. Examples of notch-type seal joints are shown in Fig. 3.

8.9.3 *Crimp Joints*—Crimp-type seal joints, made with hand tools or power hand tools, shall be made on applicable strapping without cracking and tearing of the seal metal. Crimped seal joints are usually intended for use with dry Type 1 heavy-duty strapping, primarily where severe impact or heavy stresses on the strap and joint may be encountered. Crimp joints may also be used with lubricated (waxed) strapping, provided the loss in friction is compensated for by adding sufficient additional seals and crimps, or by using "Grit"-type friction seals. Crimp seal joints when used with Type 1 heavy-duty (high-tension) strapping in sizes 3/4 by 0.031 in. (19.05 by 0.79 mm) or greater must have a minimum joint efficiency of 75 % based on the minimum breaking strength of the applicable strapping size as shown in Table 2 when tested as specified in 13.5. Three or more crimps will be required to attain or exceed the 75 % joint efficiency as determined by seal, strap, and strap finish combination. Increased joint strength can be obtained by the addition of more seals and crimps. Examples of crimp-type seal joints are shown in Fig. 1.

8.9.4 Seal joint efficiency tests should be performed periodically on both notch- and crimp-type joints to ensure that the seal and sealer combination provides the desired joint strength.

8.9.5 Die-cut sealless joints shall have a minimum joint

TABLE 6 Metal Bend Test Requirements for Strapping

Thickness		Number of Bends
in.	(mm)	
0.010	(0.25)	15
0.012	(0.31)	12
0.015	(0.38)	12
0.018	(0.46)	10
0.020	(0.51)	8
0.022	(0.56)	6
0.023	(0.58)	6
0.025	(0.64)	6
0.028	(0.71)	5
0.030	(0.76)	5
0.031	(0.79)	5
0.035	(0.89)	5
0.044	(1.12)	3
0.050	(1.27)	3
0.057	(1.45)	3

efficiency of 75 % based on the minimum breaking strength of the applicable strapping size as shown in Table 1 or Table 2, when tested as specified in 13.5. For exceptions, see AAR General Rules 15.

8.9.6 Spot-welded sealless joints shall have a minimum joint efficiency of 75 % based on the breaking strength of the applicable strapping size as shown in Table 1 or Table 2, when tested as specified in 13.5.

8.10 *Galvanized Strapping*—Finish B galvanized strapping shall have the following minimum coating weights or thicknesses, or both, when tested as specified in 13.7 (see 10.2.3 and Table 5).

Grade 1—0.30 oz/ft² (92 g/m²) of surface or 0.0005 in. (0.013 mm) thick.

Grade 2—0.18 oz/ft² (55 g/m²) of surface or 0.0003 in. (0.008 mm) thick.

Grade 3—In accordance with manufacturer's commercial practice but no less than 0.06 oz/ft² (18 g/m²) of surface or 0.0001 in. (0.003 mm) thick.

8.10.1 Edges of Grades 1, 2, and 3 shall not show signs of copper sulfate when tested in accordance with 13.10.

8.11 *Ductility of Strapping Coating*—Finish A, painted finish, Finish B, galvanized, Finish C, metallic-filled strapping shall not crack or flake on the outside of the bent portion, except that cracks on the strapping shall be disregarded within a distance from the edge of the strapping equal to one fourth of the width when tested as specified in 13.8.

8.12 *Base Metal Ductility (Bend Test)*—Strapping of various thicknesses shall withstand the minimum number of bends in one area as shown in Table 6. The test procedure is described under 13.2, and shall be conducted on the final finished product.

8.13 *Straightness—Type 1 Strapping:*

8.13.1 *Camber*—Camber in the strapping shall not be more than 1/2 in. (12 mm) in any 8-ft (2.4-m) length, when measured in accordance with Specification A 109, Table 10.

8.13.2 *Coil Set (Bundle Curve)*—Strap ends shall not rise from horizontal flat plain more than 2 in. (50.8 mm) in any 8-ft (2.4-m) long section of strap.

8.13.3 *Spiral Twist (Cork Screw Effect)*—Twist must not exceed 20° in any 8 ft (2.4 m) long section of strap, when laid on horizontal flat surface.

9. Coil Configuration and Permissible Weight Variations

9.1 *Type 1 Coils*—Type 1 and Type 2 strapping shall be oscillated (mill)-wound coils weighing not less than 90 lb (41 kg) or more than 110 lb (50 kg) (see Fig. 2) and ribbon-wound coils weighing not less than 55 lb (25 kg) nor more than 110 lb (50 kg) when put up as specified in Table 4 (also see Fig. 3). Oscillated- and ribbon-wound coils of strapping are used in different types of dispensers.

9.2 *Type 1 Core Liners*—Type 1 strapping in oscillated-wound coils shall be wound on core liners. Strapping in ribbon-wound coils shall not require core liners.

9.3 *Type 2 Coils*—Type 2 strapping shall be in small or large coils. Small coils shall be in one piece, not less than 200 ft (61 m) or more than 400 ft (122 m) in length and supplied in individual dispensing cartons. Large coils, oscillated (mill) wound, shall weigh no less than 90 lb (41 kg) nor more than 110 lb (50 kg), and large coils, ribbon wound, shall weigh not

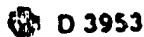

TABLE 7 Single Sampling Plan for Normal Inspection

Properties & Attributes ^a	Plan of Sampling	Acceptable Quality Level
8.1 through 8.13.3	5.2	4.5%
9.1 through 9.3	Level 1	4.0%
10.1 through 10.3.3	Level 1	4.0%

^a References are made to paragraphs in this specification.

less than 50 lb (23 kg) nor more than 125 lb (57 kg) when put up as specified in Table 4.

10. Workmanship, Finish, and Appearance

10.1 *Type 1 Strapping and Seals*—Strapping shall be straight, smooth, and clean and shall be free of kinks, grooves, waves, edge curvature, indentations, excessive oil, and cracks. Seals shall be free of dents, burrs, and slivers, and not be deformed.

10.1.1 *Style of Edges*—Edges of Type 1 strapping shall be as cut, milled, or formed in accordance with current commercial practice and shall be free of sharp edges, burrs, and slivers prior to the finish application.

10.2 *Strapping Finish*—The finished coat of the strapping shall be adherent, free of scratches, runs, embedded foreign matter, uncoated areas, rust areas, or loose oxide scale.

10.2.1 *Finish A*—Finish A strapping shall have surfaces and edges coated with an organic coating that shall yield a film as specified in 10.2. On Types 1 and 2, cut-to-length strapping, cuts or nail holes or slots, or combination thereof, may be made after the application of the finish coating.

10.2.2 *Finish B*—Finish B strapping shall have surfaces and edges coated with zinc by either the hot-dipped or electro-deposit process (see 8.10 and 10.2.3).

10.2.3 *Finish B Galvanized Strapping*—The choice between Grades 1, 2, or 3 Finish B, galvanized strapping should be guided by the service expected, considering that the protection afforded by the coating is proportional to the weight of the coating. Grades 1 and 2 Finish B zinc-coated strappings are commonly referred to as government-grade galvanized coating, and Grade 3 having a lighter zinc coating is referred to as commercial-grade galvanized strapping (see 8.10).

10.2.4 *Finish D (Uncoated Strapping)*—Finish D strapping shall be finished a natural black or blued, browned, or bright, as resulting from the manufacturing process. Surfaces shall be lubricated as indicated in 8.3 unless otherwise specified.

10.3 *Seal Finish*—The finished coat of the seal shall be adherent, free of scratches, runs, embedded foreign matter, uncoated areas, rust areas, or loose oxide scale. Edges on the seals are bright unfinished metal as a result of the manufacturing process.

10.3.1 *Finish A*—Unless otherwise specified (see 5.1.2), seals shall be finished in accordance with the manufacturer's commercial practice. The outer surface of the seal shall be coated with an organic coating that shall yield a film as specified in 10.2.

10.3.2 *Finish B*—Galvanized seals, Grades 1 and 2, shall be coated as specified in 8.10. Grade 3 galvanized seals shall be coated in accordance with manufacturer's standard commercial practice.

10.3.3 *Finish C*—Finish C seals shall be finished a natural

black or blued, browned or bright, as resulting from the manufacturing process.

11. Sampling Plan

11.1 Unless otherwise specified in contract or order, sampling for acceptance inspection and testing by attributes shall be performed in accordance with applicable provisions set forth in MIL-STD-105, Tables 1 and II-A. Inspection levels and acceptable quality level (AQL) as listed in Table 7 of this document apply.

11.2 *Lot Size*—The lot size shall consist of all product from a specific production run, or that amount offered for acceptance at one time as applicable. In the case of strapping, it shall be of one class, type, finish, grade, duty, and size. In the case of seals it shall be of one type, style, class, finish, and width.

11.3 *Unit Sample*—One coil or one seal shall be considered a unit. Examination of a coil for imperfections, as applicable, shall be made on eight consecutive feet (2.5 m) of the coil, provided that the condition of the remainder of the coil is representative of the length of strap inspected. The test specimen of strapping can be taken from either end of the coil. When the rest of the coil is not representative, examination for permissible number and strength of welds, as applicable, shall be made on the entire length of the coil regardless of the condition of the coil.

11.4 *Rate of Sampling*—The rate of sampling shall be in accordance with Table 7, excerpted from applicable portions of MIL-STD-105D. Similarly, the acceptable quality level (AQL) shall be as indicated in Table 7.

11.5 *Product Quality*—A supplier shall be responsible for providing product at a quality level that shall meet the requirements of this specification, or an equivalent as agreed upon between purchaser and seller as part of the order of contract. The purchaser does reserve the right to perform any inspections as deemed necessary to assure supplies and services conform to preestablished requirements.

12. Number of Tests and Retests

12.1 *Acceptance Tests*—For the determination of break strength, elongation, ductility, joint efficiency, and coating tests, a single specimen shall be considered a complete test of a unit sample.

12.2 *End-Use Testing*—Where field activities require testing to assure compliance with Tables 1, 2, 4, and 5, the average of test values from three strap (or sealed-joint) specimens of sufficient size are required.

12.3 *Retests*—When determining break strength, elongation, or joint efficiency, a retest shall be permitted if the location of strap failure is outside the 6-in. (152-mm) gage length, or within 1 in. of the holding jaws, or both.

13. Test Methods

13.1 *Dimensions and Weight*—Examine the end item to determine compliance with dimensional, weight, and tolerance requirements. Determine dimensions on flat strapping on base metal after the paint, wax, zinc, or oxide scale has been removed. Any nonconforming dimensions or weight shall be so classified.

13.2 *Metal Bend Test for Strapping*—Fasten a test specimen from a sample unit of strapping in the jaws of a vise

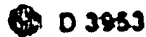

and bend by hand over a radius of $\frac{1}{16}$ in. (1.6 mm). Formed edges may be removed before testing. One bend shall consist of a 90° bend in one direction and return to the original position. Make successive bends in opposite directions. Discard cracking or flaking of the coating during testing. Strapping of the various thicknesses shall withstand the minimum number of bends in one area, as shown in Table 6. The inability of the strapping to make the minimum bends before breaking into two pieces shall constitute failure of this test. Test with the final finished product.

13.3 Breaking Strength of Strapping—Measure breaking strength on a tension tester capable of load accuracies to within $\pm 1\%$. Select the load range in which the point of maximum force will fall between 10 and 95 % of full scale. The test specimen should be approximately 12 in. (305 mm) in overall length, but not less than 8 in. (203 mm). If elongation is also to be measured, a series of transverse scribe marks shall be placed along the length of specimen at 1-in. intervals in sufficient number to ensure breakage of specimen occurs within a scribed 6-in. (152 mm) length. Place the test specimen in the tension machine so that there is at least a 6-in. (152-mm) gage length centered between the jaws of the clamping device. Use suitable clamping arrangements to minimize slippage or breakage within the clamps. Make manual adjustments to remove slack before the tester is activated. Conduct the test using a maximum crosshead separation speed of $2\frac{1}{2}$ in./min (64 mm). Read the maximum force required to break the strap. Discard all data when the break occurs within 1 in. (25 mm) of the clamp and retest in accordance with 12.3.

13.4 Elongation of Strapping—Measure percent elongation at break at the time as the breaking strength and using the same procedure (see 13.3). Elongation is the permanent increase in length which results from the breaking strength test. Place the test specimen in the tension machine so that a 6-in (152-mm) section between gage marks is centered between the clamps. After the break, the two parts of the specimen are removed from the clamps, placed on a flat surface, and carefully joined together at the break point. The distance between the gage marks is measured using an accurate scale or vernier. The distance between gage marks is measured using a scale marked in 0.01-in. (0.25-mm) increments, and read to the nearest 0.01 in. Percent elongation is defined as the length between gage marks after the test minus the original length (6 in.) divided by the length before the test, multiplied by 100. Discard all test results where the break occurs within 1 in. (25 mm) of a gage mark, and retest in accordance with 12.3.

13.5 Joint Strength as Percent of Breaking Strength:

13.5.1 Method of Joining by Seals—Make a seal joint with a sample seal with a single or double notch, or double or more crimps as applicable, joining the two pieces of Type 1 strapping. Check the joint to determine compliance with the joint-making requirements (see 8.9).

13.5.2 Determination of Joint Strength—Determine seal joint strength by the same procedure used for determining breaking strength (see 13.3). The sealed joint is to be positioned midway between the holding jaws. The maximum force can be read directly from the indicating device to the nearest scale division.

TABLE 8 Thickness of Steel Plate for Bend Test Fixture

Strapping Thickness	Finish A		Finish B	
	in.	mm	in.	mm
0.028	(0.71)	$\frac{1}{8}$	(10)	1.6
0.029	(0.74)	$\frac{1}{8}$	(10)	1.6
0.031	(0.79)	$\frac{1}{8}$	(10)	1.6
0.035	(0.89)	$\frac{1}{8}$	(10)	1.6
0.044	(1.12)	$\frac{1}{4}$	(12)	1.9
0.050	(1.27)	$\frac{1}{4}$	(12)	1.9
0.057	(1.45)	$\frac{1}{4}$	(12)	1.9

13.5.3 Determination of Percent of Breaking Strength—Determine percent of breaking strength by dividing the seal joint strength value by the minimum breaking strength in accordance with strapping type and size tested and multiplying by 100 (see Tables 1 and 2).

13.6 Determination of Welded Joint Strength—Determine welded joint strength for manufactured process welds with Type 1 strapping by the same procedure used for determining breaking strength (13.3), except that joint efficiency shall be equal to the ratio of minimum breaking strength of the strapping multiplied by 100.

13.7 Galvanized Coating:

13.7.1 Weight Loss Test—Test a 6-in. (152-mm) test specimen from a sample unit of Finish B strapping in accordance with Test Methods A 90 for loss of coating weight. Loss of weight less than that shown in Table 5 applicable to strapping width shall constitute failure of the specimen to meet the zinc coating requirements of 8.10.

13.7.2 Thickness Test—Test a 6-in. (152-mm) test specimen from a sample unit of Finish B strapping for thickness of zinc coating in accordance with Method B 504, or the magnetic gage or eddy-current method shall be permitted with proper calibration.

13.8 Ductility Test, Coating—Test a 12-in. (304-mm) test specimen from a sample unit of strapping for ductility of coating to determine compliance with 8.11. Determination of cracking or flaking of coating shall be by visual examination without magnification. Perform the tests in accordance with Practice D 4332. Take care during the tests to avoid scratching or abrading the coating in the area of the bend. Perform the tests as follows:

13.8.1 Bend strapping 0.025 in. (0.64 mm) thick or less cold, once through 180°, over two thicknesses of the strapping material. Use vise with smooth jaws for this test.

13.8.2 Bend strapping 0.028 through 0.057 in. (0.71 through 1.45 mm) thick, once through 180°, over the rounded end of a steel plate of convenient size and a thickness within $\pm \frac{1}{16}$ in. (0.40 mm) of that shown in Table 8. Bend by clamping the specimen against the plate in a vise, bending the specimen slowly by hand over the rounded end of the plate as far as possible, then completing the bend by inverting the plate and specimen and tightening the vise until the specimen is tight against the plate.

13.9 Lubrication Test—To determine an acceptable level of lubrication, apply the straps to a rigid work bench or fixture using the strapping manufacturer's manual or power-tensioning machine. The straps shall have a capability of being tensioned to the percent of rated breaking strength of

the strapping as shown below, and should tension smoothly without binding (see 8.3)

50 %—All sizes of Type 1 regular-duty strapping (see Table 1).

40 %—Type 1 heavy-duty strapping up to and including $\frac{1}{4}$ by 0.028 in. (19.05 by 0.71 mm) (see Table 2).

30 %—Type 1 heavy-duty strapping $\frac{1}{4}$ by 0.029 in. (19.05 by 0.75 mm) (see Table 2). Larger sizes, for which feed wheel type tensioning tools may be unavailable, and strap finishes are ordered and supplied without lubrication coating, are exempt from the lubricity test.

13.10 *Edge Test*—Test a sample unit of Finish B galvanized-coated strapping in accordance with Test Method A 239 for the presence of zinc coating and absence of copper sulfate on the edge; use two Preece test dips for Grade 1 and one Preece test dip for Grades 2 and 3 (see 4.1.2.1 and 8.10). Nonconformance to the requirements shall constitute failure of the test.

14. Precision and Bias

14.1 *Precision and Bias*—Precision and bias measurements for applicable test methods are currently under study by the Strapping Task Group of ASTM Subcommittee D10.14.

15. Rejection and Retesting

15.1 Any coil of strapping (or specimen of seals) that fails to meet the test requirements of this specification may be rejected. Rejection should be reported to the producer or supplier promptly and in writing. In case of dissatisfaction with the results of the test, the producer or supplier may request retesting (see 12.3).

16. Certification

16.1 At the time of shipment when specified in the contract or order, the manufacturer shall certify that the end product complies with the requirements of this specification.

17. Preparation for Delivery

17.1 Preparation for delivery shall be either overseas/waterproof packaging or commercial packaging when specified in contract or order.

WRAP WITH THREE STRAP TIES
SPACED 120° APART.

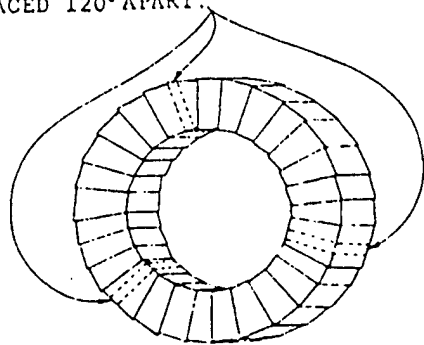

FIG. 4 Wrapping and Tie Straps

18. Overseas/Waterproof Packaging

18.1 *Strapping*—Type 1 and Type 2 strapping, oscillated- or ribbon-wound as specified (see 9.1) shall be wrapped or unit packed in sizes and quantities shown in Table 4.

18.1.1 *Wrapping*—Each coil or multiple of coils of Types 1 and 2 strapping, as specified in Table 4, shall be spiral-wrapped with paper by means of a coil-wrapping machine using tensioning and edge-folding device. Wrapping paper shall be either crepe or hard-sized noncreped paper at the discretion of the supplier (see Fig. 4). Alternatively, for protection instead of wrapping, Types 1 and 2 heavy-duty strapping, in ribbon-wound coils only (when stacked on a skid or platform), shall be capped with a waterproof reinforced paper as shown in Fig. 4.

18.1.1.1 *Creped Material*—Each coil that is wrapped in accordance with 18.1 shall be spiral-wrapped with 45/40/30 duplex reinforced waterproof kraft paper. The paper shall consist of two sheets of kraft paper, 45 lb (20.4 kg) and 30 lb (13.6 kg) basis weight per ream of 500 sheets 24 by 36 in. (6 ft² or 0.557 m² per sheet), respectively, laminated together with asphalt in which are embedded reinforcing cords or strands of fiber running in the machine direction of the paper, not more than $\frac{3}{8}$ in. (9.52 mm) apart, having the 45-lb (20.4-kg) sheet saturated, coated, or infused with asphalt. Creping shall be in the machine direction. The minimum construction before creping shall be 45/40/30 when applying the paper. The tension shall be adjusted so that not over 8 % stretch will be left in the paper. The edge-folding device shall fold either one or both edges of the web of paper to give a rolled edge with a minimum of two thicknesses. Each wrap shall overlap each preceding layer of wrap at least 50 %. The saturated, coated, or infused 45-lb (20.4-kg) kraft shall be on the outside of the wrapped coil or coils. Wrapping shall be accomplished in such a manner as to provide a neat and compact unit pack (see Fig. 4).

18.1.1.2 *Hard-Sized Noncreped Materials*—Alternatively, each coil that is wrapped in accordance with 18.1 shall be spiral-wrapped using a hard-sized noncreped paper $2\frac{1}{2}$ in. (63.5 mm) wide, having a basis weight per ream of 500 sheets 24 by 36 in. (6 ft² or 0.557 m²) of 105 lb (47 kg) ± 5 lb (2.3 kg). The paper may be of natural kraft color. The dry tensile strength shall be 105 lbf (467 N)/1 in. (25.4 mm) of width in the machine direction with a tolerance of ± 5 lbf (22 N). The wet tensile strength shall be not less than 25 lbf (111 N)/1 in. of width in the machine direction when measured under standard laboratory conditions after 20-min immersion. In applying this material, the individual turns of the spiral wrapping shall be held under tension by spot gluing at intervals along the length of the spiral wrapping in such a way that each individual turn is firmly adhered to the preceding turn in several places along the circumference of each turn. Wrapping material shall be fed into the coil-wrapping machine in continuous strips $2\frac{1}{2}$ in. (63.5 mm) wide. The strips, when glued in cross sections, shall resemble a modified letter S, with $\frac{1}{4}$ in. (6.3 mm) of material folded back on itself 180° along the entire length of each edge. The exposed edge of the wrap shall be folded under. The edges of the wrapping material shall be maximum of $\frac{1}{4}$ in. (19.05 mm) apart on the outer circumference of the coil. The use of three equally spaced steel straps on the outside of the strapping as specified in 18.2 does not apply.

D 3953

18.2 *Coin-Te Strapping*—Each individual coil of Types 1 and 2 regular- and heavy-duty strapping, either overlapped- or ribbon-wound, shall be strapped with a minimum of three equally spaced Type 1 regular-duty steel tie straps not less than $\frac{1}{2}$ by 0.020 in. (12.7 by 0.51 mm). The straps may be applied either under or over the outer spiral wrap when used. When straps are applied under the spiral wrap, the end of the wrap shall be secured by either tucking the end under adjacent wrap or by adhesive, tape, or by the application of one Type 1 regular-duty strap not less than $\frac{1}{2}$ by 0.020 in. (12.7 by 0.51 mm). See Fig. 4.

18.2.1 Alternatively, coils of Types 1 and 2 strapping, when ordered and unit packed in quantities as specified in Table 4, shall be packed in an end loading, full overlap slotted container constructed from V3C fiberboard or equivalent. When practical, containers shall be uniform shape and size, be of minimum cube, and tare consistent with protection required. Containers shall be closed, sealed, and reinforced in accordance with applicable container specifications or supplier's commercial practice.

18.3 *Seals*—Seals of one size, class, finish, type, and style (or nomenclature) unit packed in fiberboard boxes in accordance with supplier's commercial practice, shall be over-packed in a snug-fitting full overlap slotted container constructed from V3C fiberboard or equivalent. The box shall be reinforced with a liner constructed from V3C fiberboard or equivalent. The liner shall be scored to cover the end and side panel of the box. Flutes of the liner shall be perpendicular to the top of the box. Unless otherwise specified, the height of the liner shall be the full inside depth of the box. The liner shall fit snugly inside the intermediate box. This over-pack box shall be closed with not less than two $\frac{3}{8}$ by 0.015 in. (9.52 by 0.38 mm) Type 1 regular-duty straps. An alternative method is to use eight overlapped corner sections forming an over-pack ("Adjusta-Pack" Method) constructed from V3C fiberboard or equivalent. A liner is not required with the "Adjusta-Pack". The "Adjusta-Pack" shall be closed with not less than four (2 by 2 pattern) $\frac{3}{8}$ by 0.015 in. (9.52 by 0.38 mm) Type 1 regular-duty straps. Dimensions of the over-pack containers shall be determined by the supplier's

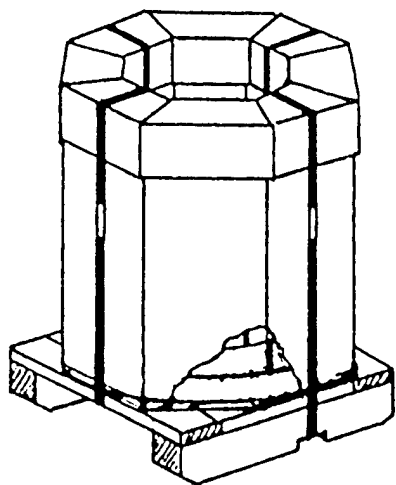

FIG. 5 Single Pile Capped with Corrugated Shroud

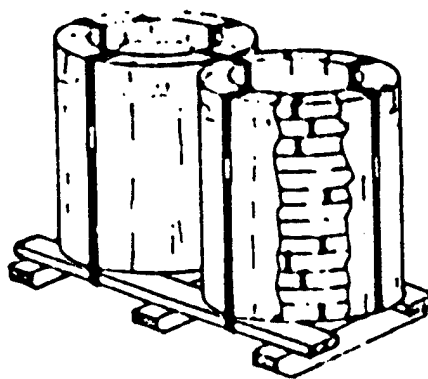

FIG. 6 Double Pile Capped

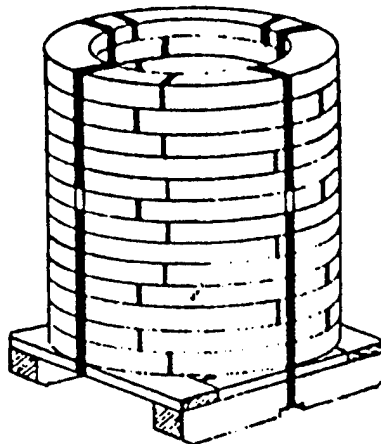

FIG. 7 Single Pile Bare

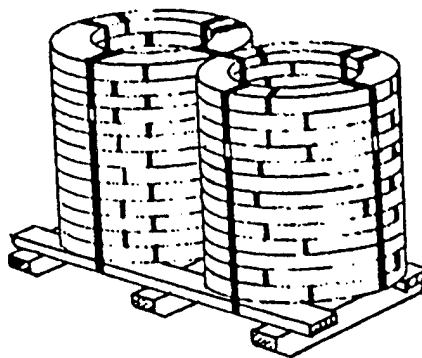

FIG. 8 Double Pile Bare

commercial package and number of commercial packages to be fitted into the over-pack. The dimensions shall be as when specified in the order or as mutually agreed upon between supplier and purchaser. However, the maximum inside dimensions of the over-pack container shall not exceed 110 in. (2540 mm), and the gross weight of the over-pack shipping container shall not exceed 120 lb (54.4 kg).

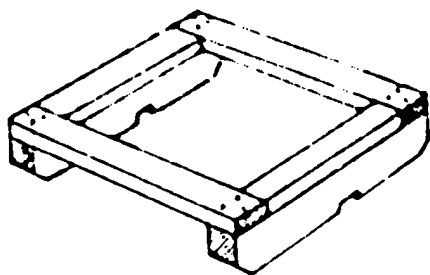
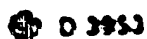

FIG. 9 Single Pile Platform

18.4 Packing

18.4.1 *Strapping*—Coils of flat steel strapping unit packed as specified in 18.1 through 18.3 shall be packed as single or double pile.

18.4.1.1 *Single Pile*—Coils of strapping shall be evenly stacked in a single pile on a platform or skid (see Figs. 5 and 7) and secured to the platform or skid as follows:

(1) *Oscillated-Wound Coils*—With four equally spaced straps not less than $\frac{1}{4}$ by 0.028 in. (19.05 by 0.71 mm) Type 1 regular-duty or $\frac{1}{4}$ by 0.025 in. (19.05 by 0.64 mm) Type 1 heavy-duty strapping. Maximum stack height shall be 32 in. (813 mm) not including skid.

(2) *Ribbon-Wound Coils*—With four equally spaced straps not less than $\frac{1}{4}$ by 0.031 in. (19.05 by 0.79 mm) or $\frac{1}{4}$ by 0.035 in. (19.05 by 0.89 mm) Type 1 regular-duty strapping. Maximum stack height shall be 34 in. (864 mm), not including skid.

18.4.1.2 *Double Pile*—Coils of strapping, either oscillated- or ribbon-wound, shall be stacked in two even piles in a platform or skid (see Figs. 6 and 8) and secured to the platform or skid with seven equally spaced straps not less than $\frac{1}{4}$ by 0.031 in. (19.05 by 0.79 mm) or $\frac{1}{4}$ by 0.035 in.

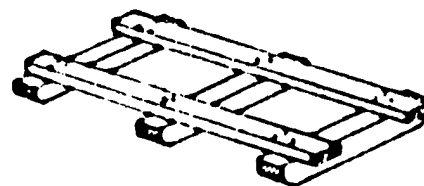

FIG. 10 Double Pile Platform

(19.05 by 0.89 mm) Type 1 regular-duty strapping (see 18.4.1.1 for allowable stack heights). The two straps on each side of each pile shall encircle the inside and outside of the stacked coils and cross member of the skid. Each strap on the ends shall encircle the inside and outside of the stacked coils. The center strap shall be applied through the eyes of both piles and around the center runner of the skid. For basic design of platform or skid see Figs. 9 and 10.

18.4.1.3 *Exterior Container*—Coils of strapping unit packed as specified shall be packed in a close-fitting wood box. For shipments to DOD, containers shall conform to overseas type of PPP-B-601 or Class 2 of PPP-B-621. Closure and strapping (as applicable) shall be in accordance with container specifications.

18.4.2 *Seals*—Unit packs will be over-packed in a close-fitting wood box. For DOD shipments, containers shall conform to overseas type of PPP-B-601 or Class 2 of PPP-B-621. Closure and strapping (as applicable) shall be in accordance with container specifications.

19. Commercial Packaging

19.1 Commercial packaging shall be in accordance with Practice D 3951.

20. Keywords

20.1 baling; bundling; earloading; closing; palletizing; steel; strapping; unitizing

The American Society for Testing and Materials takes no position respecting the validity of any patent rights asserted in connection with any item mentioned in this standard. Users of this standard are expressly advised that determination of the validity of any such patent rights, and the risk of infringement of such rights, are entirely their own responsibility.

This standard is subject to revision at any time by the responsible technical committee and must be reviewed every five years and if not revised, either reapproved or withdrawn. Your comments are invited either for revision of this standard or for additional standards and should be addressed to ASTM Headquarters. Your comments will receive careful consideration at a meeting of the responsible technical committee, which you may attend. If you feel that your comments have not received a fair hearing you should make your views known to the ASTM Committee on Standards, 1916 Race St., Philadelphia, PA 19103.