

REPORT DOCUMENTATION PAGEForm Approved
OMB No. 074-0188

Public reporting burden for this collection of information is estimated to average 1 hour per response, including the time for reviewing instructions, searching existing data sources, gathering and maintaining the data needed, and completing and reviewing this collection of information. Send comments regarding this burden estimate or any other aspect of this collection of information, including suggestions for reducing this burden to Washington Headquarters Services, Directorate for Information Operations and Reports, 1215 Jefferson Davis Highway, Suite 1204, Arlington, VA 22202-4302, and to the Office of Management and Budget, Paperwork Reduction Project (0704-0188), Washington, DC 20503

1. AGENCY USE ONLY (Leave blank)		2. REPORT DATE 20 Dec 1996	3. REPORT TYPE AND DATES COVERED	
4. TITLE AND SUBTITLE ADVANCED DISTRIBUTED SIMULATION TECHNOLOGY II (ADST-II) Air -To-Ground Battlefield Combat Identification			5. FUNDING NUMBERS N61339-96-D-0002	
6. AUTHOR(S)				
7. PERFORMING ORGANIZATION NAME(S) AND ADDRESS(ES) Lockheed Martin Corporation Information Systems Co. 12506 Lake Underhill Road Orlando, FL 32825			8. PERFORMING ORGANIZATION REPORT NUMBER ADST-II-CDRL-028R-9600335-A	
9. SPONSORING / MONITORING AGENCY NAME(S) AND ADDRESS(ES) NAWCTSD/STRICOM 12350 Research Parkway Orlando, FL 32826-3224			10. SPONSORING / MONITORING AGENCY REPORT NUMBER	
11. SUPPLEMENTARY NOTES				
12a. DISTRIBUTION / AVAILABILITY STATEMENT A - Approved for public release; distribution unlimited.			12b. DISTRIBUTION CODE	
13. ABSTRACT (<i>Maximum 200 Words</i>) The Air-to-Ground Battlefield Combat Identification (ATG-BCI) experiment was an exercise conducted at the Aviation Testbed at Fort Rucker, Alabama in August 1996. The exercise was sponsored by the Program Manager Combat Identification (PM-CI) and the U.S. Army Simulation, Training, and Instrumentation Command (STRICOM), Orlando, FL. The experiment employed virtual simulation to depict an aviation task force conducting operations during various scenarios. The purpose of the ATG-BCI was to explore the potential of new battlefield combat identification systems. The new technologies being explored included the Enhanced Battlefield Combat Identification System (EBCIS), Enhanced Forward Air Controller (EFAC), Situational Awareness Data Link (SADL), Forward Observer/Forward Air Controller Plus(FO/FAC+), Situational Awareness Beacon with Reply (SABER), and SINGARS SIP+. <div style="text-align: center; font-size: 2em; font-weight: bold;">19970630 094</div>				
14. SUBJECT TERMS ADST-II;STRICOM;ATG-BCI;Simulation; BATTLEFIELD IDENTIFICATION;			15. NUMBER OF PAGES 21	
			16. PRICE CODE	
17. SECURITY CLASSIFICATION OF REPORT UNCLASSIFIED	18. SECURITY CLASSIFICATION OF THIS PAGE UNCLASSIFIED	19. SECURITY CLASSIFICATION OF ABSTRACT UNCLASSIFIED	20. LIMITATION OF ABSTRACT UL	

NSN 7540-01-280-5500

Standard Form 298 (Rev. 2-89)
Prescribed by ANSI Std. Z39-18
298-102

EXCISE QUANTITY UNCLASSIFIED

**ADVANCED DISTRIBUTED
SIMULATION TECHNOLOGY II
(ADST II)
AIR-TO-GROUND BATTLEFIELD
COMBAT IDENTIFICATION
VIRTUAL EXPERIMENT (DO #0021)
CDRL AB01
FINAL REPORT**



FOR: NAWCTSD/STRICOM
12350 Research Parkway
Orlando, FL 32826-3224
N61339-96-D-0002
DI-MISC-80711

BY: Lockheed Martin Corporation
Martin Marietta Technologies, Inc.
Information Systems Company
12506 Lake Underhill Road
Orlando, FL 32825

Table of Contents

1. INTRODUCTION	1
1.1 Purpose.....	1
1.2 Contract Overview	1
1.3 Experiment Overview.	1
1.4 Technical Overview	1
2. System Description	1
2.1 Aviation Test Bed	1
2.2 Simulated Warfighting Systems.....	4
2.2.1 Combat Identification Systems	5
2.2.1.1 ATG BCIS Model 2	5
2.2.1.2 Forward Observer/Forward Air Controller (FO/FAC+)	5
2.2.1.3 SINCGARS SIP +	5
2.2.1.4 Enhanced Forward Air Controller (EFAC).....	6
2.2.1.5 Situational Awareness Data Link (SADL).....	6
2.2.1.6 Situational Awareness Beacon with Reply (SABER).....	6
2.2.1.7 Multi-Purpose Digital Display (MPDD).....	7
2.2.2 Simulated Forces and Equipment	7
2.2.2.1 Modular Semi-Automated Forces (ModSAF)	7
2.2.2.2 SINCGARS Radio Model (SRM) / SINCGARS Radio Emulator (SRE) ..	8
2.2.3 Vehicle Simulators.....	9
2.2.3.1 Rotary Wing Aircraft (RWA) Simulator.....	9
2.2.3.2 Fixed Wing Aircraft (FWA) Simulator.....	10
2.3 Support Systems.....	10
2.3.1 Transmission (Device) - Cell Adapter Unit (XCAU)	10
2.3.2 Data Logger.....	11
2.3.3 Time Stamper.....	11
2.3.4 Stealth System.....	11
2.4 Terrain Database	12

2.5 Scenarios	12
2.6 Legacy	13
3. Conduct of the Experiment.....	13
3.1 Pilot Training	13
3.2 Experimental Trial Runs	13
4. Observations and Lessons Learned.....	15
4.1 Systems Development and Integration.....	15
4.1.1 Integration Schedule.....	15
4.1.2 Maverick Missiles	16
4.1.3 SINCGARS Radio Model / SINCGARS Radio Emulator.....	16
4.2 Hardware	16
4.2.1 Supporting Equipment	16
5. Conclusion	17
6. References	17

List Of Figures

FIGURE 1 AIR-TO-GROUND COMBAT ID FLOOR LAYOUT 2
FIGURE 2 AVTB SIMNET /DIS NETWORK 4

List Of Tables

TABLE 1 ADST II AVTB ASSETS..... 3
TABLE 2 ATG-BCI SOFTWARE 13
TABLE 3 ATG-BCI DOCUMENTATION..... 13
TABLE 4 EXPERIMENTAL RUN MATRIX..... 14
TABLE 5 TRIAL DESIGNATORS 15

Executive Summary

The Air-to-Ground Battlefield Combat Identification (ATG-BCI) experiment was an exercise conducted at the Aviation Testbed at Fort Rucker, Alabama in August 1996. The exercise was sponsored by the Program Manager Combat Identification (PM-CI) and the U.S. Army Simulation, Training, and Instrumentation Command (STRICOM), Orlando, FL. The experiment employed virtual simulation to depict an aviation task force conducting operations during various scenarios. The purpose of the ATG-BCI was to explore the potential of new battlefield combat identification systems. The new technologies being explored included the Enhanced Battlefield Combat Identification System (EBCIS), Enhanced Forward Air Controller (EFAC), Situational Awareness Data Link (SADL), Forward Observer/Forward Air Controller Plus(FO/FAC+), Situational Awareness Beacon with Reply (SABER), and SINCGARS SIP+. The experiment focused on the evaluation of these new technologies in ATG Combat Identification and Digitization of the Battlefield to evaluate system performance; develop and assess tactics, techniques and procedures for their employment; generate soldier-machine performance parameters for use in constructive modeling; assess technology impact on Joint-ATG doctrine; and evaluate crew training requirements. The experiment was conducted over a period of two weeks and employed a series of scenarios with varying alternatives based on technologies and threats.

This final report addresses how the simulation systems were interconnected, the modeling of the new technologies, and the lessons learned during development and conduct of the experiment. Development of the software to support the experiment was conducted at the Operational Support Facility(OSF) in Orlando, FL. These software developments were then integrated into the Aviation Test Bed for support of the experiment. This document does not address the performance of the new technologies during the experiment as this analysis is being performed for PM-CI by COLSA Corporation.

1. INTRODUCTION

1.1 Purpose

The purpose of this final report is to document the ADST II effort which supported the Air-to-Ground Combat Identification experiment and specifically capture experiment configurations, results, observations, and lessons learned. This document does not address the operational effectiveness of the various systems or specific results of the data collected as this effort was conducted as part of a larger activity. Analysis of overall Air-to-Ground Combat Identification systems is being performed by the COLSA Corporation.

1.2 Contract Overview

The Air-to-Ground Combat Identification experiment was performed as Delivery Order (DO) #0021 under the Lockheed Martin Advanced Distributed Simulation Technology II (ADST II) contract with the U.S. Army Simulation Training and Instrumentation Command (STRICOM).

1.3 Experiment Overview.

The purpose of the ATG-BCI was to explore the potential of new ATG fratricide prevention technologies. The experiment simulated offensive and defensive operations by Blue Forces utilizing the National Training Center scenario developed for use in the Task Force XXI Advanced Warfighting Experiment.

1.4 Technical Overview

The technical approach to the ATG-BCI involved integrating several simulations and models to explore the effectiveness of several developing combat identification technologies. Rotary Wing Aircraft (AH-64) and Fixed Wing Aircraft (F-16) were integrated with the developing fratricide prevention systems to explore their performance under varying scenarios. The systems being explored included the EBCIS, SINCGARS SIP, EFAC, SABER, SADL, FO/FAC+, and BCIS Model 2. The alternatives for the experiment include varying combinations of these Combat Identification systems.

2. System Description

2.1 Aviation Test Bed

The Aviation Test Bed at Fort Rucker, AL contains a variety of simulators, networks, Semi-Automated Forces (SAF) capabilities, displays for monitoring the battlefield, utilities to facilitate execution of exercises, automated data capabilities, and a data reduction and analysis subsystem. A floor layout of the AVTB simulation and support platforms used for

the ATG-BCI are depicted in Figure 1. Table 1 lists the ADST II assets, purpose, protocol, war fighters (WF), and role players (RP) in support of the experiment.

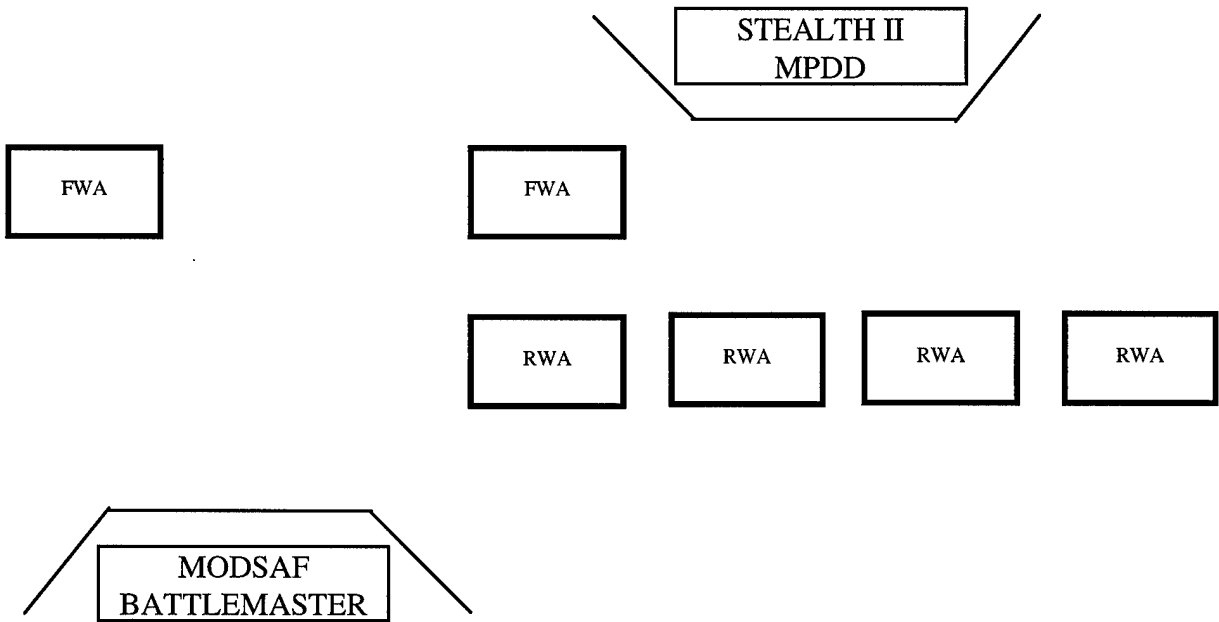

Figure 1 Air-to-Ground Combat ID floor layout

The ATG-BCI was conducted using simulation assets interconnected on Ethernet LANs via thin net cable. Some of the simulation assets used support SIMNET protocol while others use the DIS protocol. Table 1 provides a list of simulation assets used at the AVTB and their associated protocol.

Table 1 ADST II AVTB Assets

ADST II ASSET	PURPOSE	PROTOCOL
RWA Simulator (WF)	AH-64 Simulator	SIMNET
FWA Simulator (WF)	F-16 Manned Simulator	SIMNET
Stealth (RP)	Battlefield Display	DIS
ModSAF Workstations (RP)	Semi-Automated Forces	DIS
SINCGARS Radio Emulator	Radio Communication	DIS
XCAU	Allows interaction of SIMNET and DIS systems	SIMNET/DIS
Plan View Display	Terrain Map of the battlefield	DIS
Data Loggers	Record DIS PDUS	DIS
DIS Time Stamper	Time Stamp	DIS

Figure 2 depicts the SIMNET and DIS networks in support of the experiment.

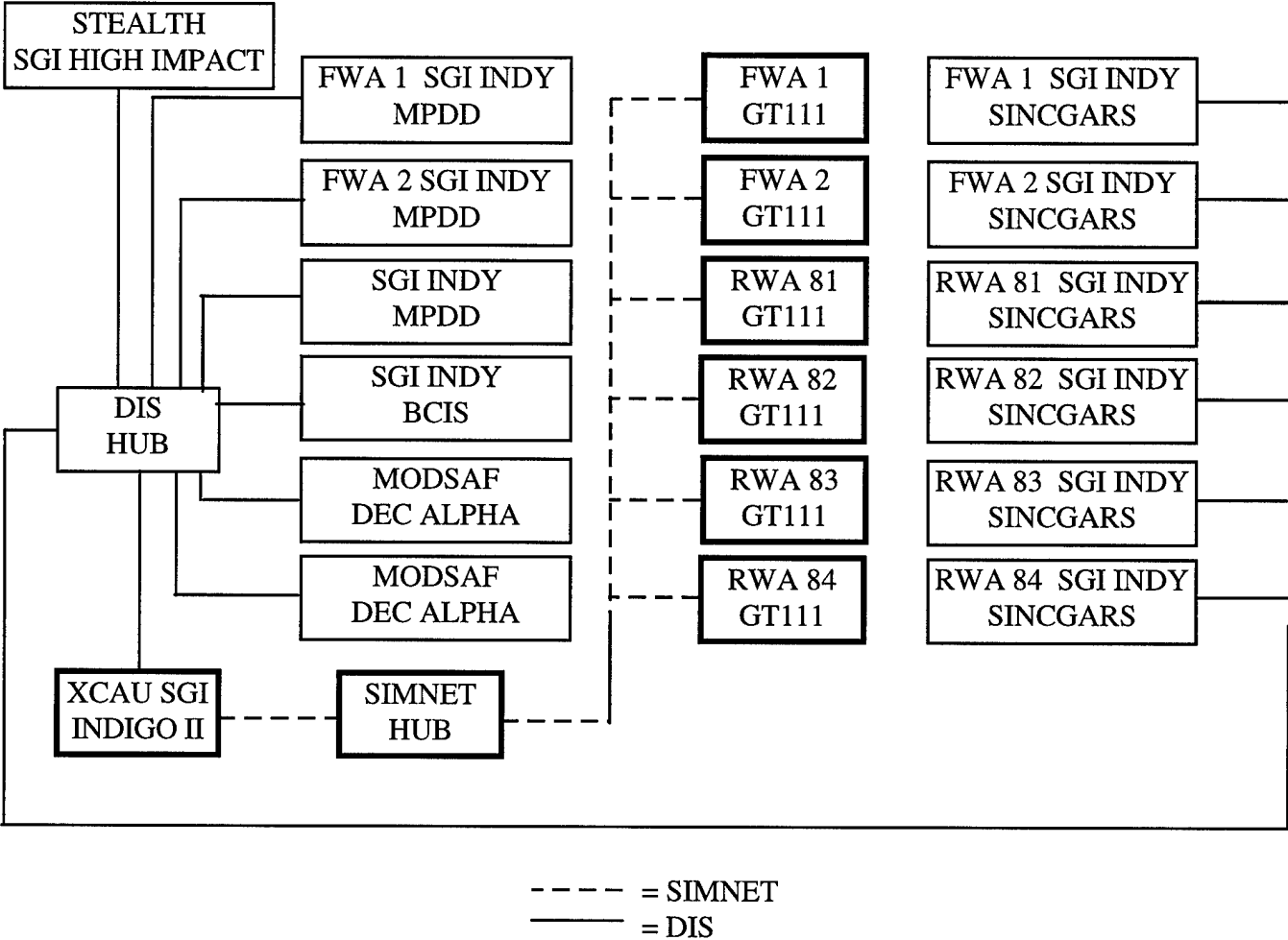

Figure 2 AVTB SIMNET /DIS Network

2.2 Simulated Warfighting Systems

The following is a discussion of each of the systems used and simulated during the ATG-BCI experiment. The systems are addressed in terms of a system description, hardware used during the experiment to represent the system, and modeling constructs used to represent the system.

2.2.1 Combat Identification Systems

The combat identification systems are the systems of interest for the experiment. These systems represent both existing and developing fratricide prevention technologies.

2.2.1.1 ATG BCIS Model 2

The BCIS model 2 is a derivative of the BCIS millimeter wave ground to ground system. The BCIS Model 2 provides the RWA with an ability to interrogate ground targets through the use of the laser range finder. A message is sent following interrogation to the BCIS model which then determines if the target is friendly, friend in sector, or unknown. For the ATG-BCI experiment, the RWA simulator was modified to receive these query result messages from the BCIS server. Embedded within the message was a result code indicating whether the queried target was friendly, friend in sector, or unknown. The RWA simulator responded by displaying a red, yellow, or blue light (note: green light is the normal display for the system however the pilots were unable to distinguish it) in the FLIR/Day-TV display corresponding to friendly, friend in sector, or unknown. Also, an audio tone was generated in the gunner's and pilot's headset to indicate the result of the query. The BCIS Model 2 was hosted on an SGI Indy with 96 MB RAM, 1 GB hard drive utilizing the Irix 5.3 Operating System.

2.2.1.2 Forward Observer/Forward Air Controller (FO/FAC+)

FO/FAC+ is an adaptation of the SINCGARS SIP+ system that provides forward observers and forward air controllers with the capability to determine precise target locations, determine if the target is friendly, and digitally communicates data requests for fire support or close air support (CAS). FO/FAC+ makes use of the SINCGARS SIP+ technology to identify friendly systems. For the ATG-BCI experiment, the FO/FAC+ system was modeled by two workstation based applications. A Stealth display was used to represent the out-the-window (or aided optics) view of the FO/FAC commander. The Stealth system operated on an SGI High Impact with 128 MB RAM, 2 GB hard drive utilizing the Irix 6.2 operating system. The Stealth was equipped with a laser range finder capability which was tied to the FO/FAC software running on a separate workstation. Upon activation of the laser range finder, the FO/FAC workstation would determine if the lased location was occupied by a friendly vehicle or unknown by using the SINCGARS SIP+ narrow mode model. The FO/FAC workstation displayed the result to the user and generated a template 9-line message. The FO/FAC software was hosted on an SGI Indy with 96 MB RAM, 1 GB hard drive utilizing the Irix 5.2 Operating System. The user had the option to complete the 9-line message and send to close air support aircraft or to abort the message.

2.2.1.3 SINCGARS SIP +

SINCGARS SIP+ was employed on rotary wing aircraft for identification of friendly forces. The SINCGARS SIP+ employs hops from the SINCGARS SIP transmission to broadcast an Intent To Shoot (ITS) message and receive a Don't Shoot Me (DSM) net reply through the RWA TADDS. For the ATG-BCI experiment, the RWA simulator was modified to internally simulate three modes of the SINCGARS SIP+ system. A three position hardware switch was used to select the SIP+ mode which affected the query region. The result of a combat

identification query produced a red or blue light in the FLIR/Day-TV display corresponding to friendly, or unknown. Also, an audio tone was generated in the gunner's and pilot's headset to indicate the result of the query. The SINGARS SIP+ software was hosted on an SGI Indy with 96 MB RAM, 1 GB hard drive utilizing the Irix 5.2 Operating System.

2.2.1.4 Enhanced Forward Air Controller (EFAC)

The EFAC system provides forward observers and forward air controllers with the capability to determine their own location, precisely locate targets, determine if the target is friendly and obtain related situational awareness data, and digitally communicate data requests for fire support and close air support. The EFAC system has five subsystems consisting of a targeting system, mission module, control display unit, EBCIS, and radio. The operational employment for the EFAC calls for the system to be collocated with the maneuver unit commander. For the ATG-BCI experiment, the EFAC system was modeled in a similar manner as the FO/FAC+ system with the exception that the determination of friend, friend-in-sector, or unknown was performed by an external Mitre BCIS server as opposed to the internal SINGARS SIP+ simulation. The EFAC software was hosted on an SGI Indy with 96 MB RAM, 1 GB hard drive utilizing the Irix 5.2 Operating System.

2.2.1.5 Situational Awareness Data Link (SADL)

SADL is an Air-to-Ground and Air-to-Air information distribution data link. For the ATG-BCI experiment, only the Air-to-Ground portion of the system was explored. SADL is a USAF system that employs Army Enhanced Position Location Reporting System (EPLRS) radio and software for Fixed Wing Aircraft and Tactical Air Control Party use. SADL operates in conjunction with the Army EPLRS net control station to receive friendly ground position information. SADL provides ground locations for the five reporting EPLRS-equipped platforms closest to the designated target, providing the pilot a Heads Up Display (HUD) visualization of the ground situation. For the ATG-BCI experiment, each FWA simulator was included with a Multi-Purpose Digital Display (MPDD) which consisted of a digital tactical map and mission planning features. The result of a SADL query produced a display onto the tactical map of the five reporting EPLRS-equipped ground platforms closest to the designated target. Standard military map symbology was used as the target icons, and an own-ship icon was displayed on the tactical map as well to provide the pilot with spatial awareness of the engagement area. The SADL software was hosted on an SGI Indy with 96 MB RAM, 1 GB hard drive utilizing the Irix 5.2 Operating System.

2.2.1.6 Situational Awareness Beacon with Reply (SABER)

SABER is a US Navy terrestrial and space-based system to locate and identify friendly force elements using beacons on host platforms and existing C2 reporting and dissemination nets. SABER has both situational awareness and friend target identification capabilities. During the ATG-BCI experiment, the target identification portion only of the SABER system was explored. The attacking aircraft would generate an "intent to shoot" message which contained a location computed by the fire control system. If any friendly vehicles were within some radius of the specified location, the friendly vehicle would respond by issuing a "don't shoot" message. The "DON'T SHOOT" text message was displayed on the aircraft's heads up display. If no vehicles responded to the query, an "unknown" message was

displayed on the heads up display. The SABER software was hosted on an SGI Indy with 96 MB RAM, 1 GB hard drive utilizing the Irix 5.2 Operating System.

2.2.1.7 Multi-Purpose Digital Display (MPDD)

The baseline MPDD system provided generic mission plan/waypoint editing features, a digital tactical map with feature, contour, and elevation data. The following modifications were made to the MPDD system:

Allow for the user to select a waypoint to navigate to. Upon selection, the waypoint displays the bearing and range to the waypoint.

Receive and buffer nine-line messages from the FO/FAC and EFAC simulations. Upon receipt of a nine-line message, the MPDD sends a HUD message to the FWA instructing the FWA to paint the message "MESSAGE" on the HUD. This informs the pilot that a nine-line message has been received by the MPDD. A button has been added to the MPDD to cause the buffered nine-line message to appear on the FWA HUD. When this button is pressed by the pilot, the MPDD sends a HUD message to the FWA instructing the FWA to paint the text of the nine-line message on the HUD. The nine-line message is also displayed in a pop-up window on the MPDD workstation. The message is then dequeued by the MPDD.

Upon receipt of a nine-line message from the FO/FAC or EFAC, display the target location and IP on the tactical map. The target location is displayed as a crosshair while the IP is textually represented.

Implementation of SABER: A button was added to the MPDD to initiate a SABER query. Upon press of this button, the MPDD determines if any friendly vehicles lie within a conic section originating and aligned with the coordinate system of the host FWA. The parameters of the conic section (full angle, range) are compile time parameters. If a friendly lies within the cone of influence, a HUD message is sent by the MPDD to the host FWA to cause the text "DON'T SHOOT" to be displayed on the FWA HUD. Otherwise the text "UNKNOWN" is displayed on the FWA HUD.

Implementation of SADL: Upon receipt of a nine-line message, display the five closest EPLRS-equipped friendly platforms to the target location specified in the nine-line message.

2.2.2 Simulated Forces and Equipment

2.2.2.1 Modular Semi-Automated Forces (ModSAF)

The manned simulators used in the Air-to-Ground Battlefield Combat ID experiment were augmented by ModSAF vehicles to provide combat arms activities. The EBCIS model was used to provide the ModSAF entities with EBCIS information to allow for interrogation by the RWA and FWA. ModSAF provides the capability to create large numbers of computer generated DIS forces that can be controlled by a small number of operators exercising supervisory control. Battalion level tactical exercises can be performed with only a handful of manned simulators. ModSAF entities can perform opposing, flanking, subordinate, and supporting force roles. The operator controls his forces by issuing Operations Orders (OPORDS) and radio Fragmentary Orders (FRAGOs) that augment the built-in automated

reactions of the ModSAF forces. This man-in-the-loop approach provides adaptive opponents without the difficulty and computational expense of full automation.

The ModSAF architecture includes the ModSAF Command Station and Simulator. The SAF workstation provides the graphical user interface from which the operator initializes exercises, observes the battle, and commands the SAF. The SAF simulator simulates all the SAF entities, units, and environmental processes. These components are typically run on separate computers distributed over a network.

The SAF workstation allows a user to monitor and control ModSAF forces and to set up exercises. The station provides the user with a two-dimensional electronic map display (Plan View Display) that is used to examine the terrain, monitor the tactical situation, and prepare orders. The workstation does no simulation; it places requests for entities to be simulated and orders to be executed into the Persistent Object (PO) database. The ModSAF simulator accepts these requests and simulates entities carrying out their orders. This division of labor is advantageous, allowing a variety of systems to generate missions for SAF units, including different workstations, Artificial Intelligence programs, as well as other ModSAF simulators.

The ModSAF components employed at the AVTB in support of the ATG-BCI experiment consisted of two DEC Alpha workstations with 128 MB RAM, 333 Mhz, and 2 gigabyte hard drive operating the Digital Unix Operating System version 3.0. This was the first use of the DEC Alpha workstations in support of an experiment and the performance of the systems was adequate. No ModSAF changes were made to support the ATG-BCI experiment.

2.2.2.2 *SINCGARS Radio Model (SRM) / SINCGARS Radio Emulator (SRE)*

The simulation of the SINCGARS radio provided the means of communications between the players. The SRM and the SRE are ADST II program assets that simulate realistic propagation effects consistent with the performance that a user could expect from the actual SINCGARS system in a real-world application. They are capable of transmitting/receiving voice and data messages from other SRMs/SREs.

The SRE is a hardware/software system that contains the SRM radio core software model. The SRE is based on the SINCGARS / Combined Arms Command and Control (CAC2) simulator. The SRE provides a realistic SINCGARS user interface, input/output system, and intercom communications.

The SRM uses a probabilistic approach to simulate random errors occurring in the transmitted data. Using a statistical model of the Bit Error Rate (BER), the SRM introduces random errors into data sets received through signal PDUs. The error rate is dependent upon signal-to-noise ratio and varies with signal frequency and locations of both the received signal source and interference. Factors in this model that determine signal-to-noise Ratio are propagation loss effects, interference, and background noise.

The DIS network interface allows the radio to communicate to other radios using DIS v2.03 standard transmitter and Signal PDUs. The network interface monitors entity state PDUs to determine the own-vehicle radio's antenna location and vehicle status.

For the ATG-BCI, six SINGARS radio models were provided by the ADST II program. These models were hosted on an SGI Indy with 96MB RAM, 1 GB hard drive, utilizing the Irix 5.2 operating system.

2.2.3 Vehicle Simulators

2.2.3.1 Rotary Wing Aircraft (RWA) Simulator

The ADST II Rotary wing aircraft is a reconfigurable real-time simulation. The simulator can be modeled as an OH-58, AH-64, or former Soviet Union helicopters. The RWA has the capability to model a 30mm cannon, Hellfire missiles, the Air to Air Stinger (ATAS), the TOW missile, a 50 caliber machine gun, the hydra 70 rocket and former Soviet Union counterpart munitions. The RWA has three seats two of which are manned at any given time by the pilot and copilot observer or gunner. The simulator consists of a single compartment manned by two crew members. All simulated vision devices within the aircraft are controlled by a GT111 computer image generator. The simulated sensors include the Day TV and the FLIR.

Vulnerability is simulated in the RWA as combat damage assessment performed when the simulated aircraft receives hit information from a direct fire source or an indirect fire source on the simulation network. Vulnerability assessment is a function of round type, location of hit, and range of firer from the impact.

For the ATG-BCI experiment, four RWA's were configured as AH-64 Apache aircraft. The aircraft were equipped with varying weapons loads of Hellfire missile, 30mm cannon, and Air-To-Air Stinger (ATAS) depending on the scenario. In addition, the RWA was modified to operate in three modes with respect to the Combat Identification technology being tested during the experiment: Baseline, SINGARS SIP+, and BCIS Model 2. This mode was selectable via a command line argument.

Under the baseline configuration, the RWA behaved as the normal SIMNET 6.6.1 release system with no Combat Identification functionality.

Under the SINGARS SIP+ system, the RWA software internally simulated the SIP+ system. Three modes of SIP+ were implemented, Narrow, Wide, and Long. The SIP+ mode of operation used was selectable by a hardware 3 position switch which was installed in each cockpit. The gunner initiated a Combat ID query by activating the laser range finder. The result of the query was displayed visually by a red or blue light being illuminated in the FLIR/Day-TV view in the gunner's station corresponding to unknown or friendly vehicle. Also, a corresponding audio tone was generated in the gunner's and pilot's headsets.

Under the BCIS system, the RWA software communicated the intent to query by the issuance of a LaserRange PDU. The result of the query was calculated externally by the MITRE BCIS model running on an independent workstation attached to the network. The MITRE BCIS model communicated the result to the RWA via a DIS Signal PDU. The result of the query was displayed visually by a red, yellow or blue light being illuminated in the FLIR/Day-TV view in the gunner's station corresponding to unknown, friend in sector, or friendly vehicle. Also, a corresponding audio tone was generated in the gunner's and pilot's headsets.

2.2.3.2 Fixed Wing Aircraft (FWA) Simulator

The ADST II Fixed Wing Aircraft is a real-time reconfigurable simulation. The FWA can model the behaviors of the USAF A-10 WarHog or the Soviet Su-25 Frogfoot depending upon the selected configuration. For the ATG-BCI, modifications were made to the FWA to allow it to simulate an F-16. The simulator has the capability to model the Maverick missile, the Sidewinder missile, the 30 mm GAU-8 gun and appropriate former Soviet Union counterpart munitions. The FWA has one seat for a pilot. The pilot views the visual environment by eight CRT monitors distributed in a pattern in front of the pilot's seat, three monitors on a top row and five monitors on a bottom row. A high resolution monitor provides a heads-up display on the bottom row center monitor.

Vulnerability is simulated in the RWA as combat damage assessment performed when the simulated aircraft receives hit information from a direct fire source or an indirect fire source on the simulation network. Vulnerability assessment is a function of round type, location of hit, and range of firer from the impact

For the ATG-BCI experiment, two FWA's were configured as F-16 aircraft. The aircraft were equipped with the Maverick missile and the 30 mm GAU-8 gun. In addition, The FWA was modified to allow the display of selected text messages on the HUD. This was to support the display of 9-line messages from a Forward Area Controller simulation. Also, this mechanism was used to display "Don't Shoot" messages associated with the SABER system.

Up to 6 lines of text are supported by the system, 20 characters per line. A single protocol data unit (PDU) added to the Data Collection Protocol allowed for any of the 6 lines to be displayed with specified text, erased, or no-operation. This flexible design allowed for the FWA software to be used across a variety of simulations, keeping the complexity of the text display logic in an external application.

2.3 Support Systems

2.3.1 Transmission (Device) - Cell Adapter Unit (XCAU)

The XCAU consists of a workstation and associated software that allows DIS simulators to interoperate with SIMNET simulators within the constraints of translated PDUs. The XCAU provides two parallel protocol translation processes: translation of DIS to SIMNET, and SIMNET to DIS. The following software changes were made to the XCAU in support of the ATG-BCI;

- Expansion of the DisConv class to include the Signal PDU.

- Translation of the SIMNET Laser Range PDU to DIS Laser Designator PDU.

- Definitization of the BCIS result PDU structure.

The host system for the XCAU was an SGI Indigo 2 with 128 MB RAM, 2 GB hard drive, utilizing the Irix 5.2 Operating System.

2.3.2 Data Logger

The Data Logger is an ADST II asset that captures the network traffic and places the data packets on a disk or tape file. The Data Logger performs the following functions:

- a. Packet Recording - Receives packets from the DIS or SIMNET network, time stamps and then writes to a disk or tape.
- b. Packet Playback - Packets from a recorded exercise can be transmitted in real time or faster than real time. The Data Logger can also suspend playback (freeze time) and skip backward or forward to a designated point in time. The logger can be controlled directly from the keyboard or remotely from the PVD. Playback is visible to any device on the network (PVD, Stealth Vehicle, a vehicle simulator, etc...).
- c. Copying or Converting - Files are copied to another file, which can be on the same or a different medium; and files from the older version of the Data Logger can be converted to a format compatible with the current version of the Data Logger.

For the ATG-BCI experiment, one data logger was employed to capture the exercise.

2.3.3 Time Stamper

The ADST II provided time stamper consisted of a video time code generator, which produced time data in days-since -1 Jan/hour/min/sec format, and an IBM-compatible Personal Computer (PC). The PC was programmed to read the video time code, convert the time data, and then generate a Time PDU, which was then issued on the DIS network each second. This provided the real world clock time on the logged data to assist in subsequent analyses.

2.3.4 Stealth System

The ADST II Stealth gives the Observer/Controller (O/C) personnel a "window" into the virtual battlefield, allowing them to make covert observations of the action occurring during the scenario. In addition, through the use of the data logger, the Stealth gives observers and analysts an After Action Review(AAR) capability. The Stealth is a visual display platform that consists of a PVD, various input devices, and three video displays that provide the operator with a panoramic view of the battlefield.

The Stealth permits the controller to fly around the virtual battlefield and view the simulation without interfering with the action. The features of the Stealth allow the observer to survey the virtual battlefield from a variety of different perspectives, including:

- a. Tethered View - Allows the user to attach unnoticed to any vehicle on the virtual battlefield.
- b. Mimic View - Places the user in any vehicle on the virtual battlefield and provides the same view as the vehicle commander.

- c. Orbit View - Allows the operator to remain attached to any vehicle on the virtual battlefield and to rotate 360° about that vehicle, while still maintaining the vehicle as a center point of view.
- d. Free Fly Mode - Permits independent 3-D movement anywhere in the virtual battlefield.

The maximum viewing range was changed from a hard-wired limitation of 5 kilometers to a user definable range which can be selected interactively using the graphical user interface (GUI). Viewing ranges between 2 kilometers and 10 kilometers are allowed by the GUI. During the Combat-ID experiment, a viewing range of 7 kilometers was used. This range applies to both the terrain horizon and the maximum viewable distance of remote vehicles.

A laser ranging capability was added to the Stealth. A laser range query may be initiated using either a Spaceball button or through the GUI. The laser range value is depicted on the graphics window as a textual two-dimensional overlay. Range values persist for a period of 5 seconds or until they are overridden by a subsequent query. A laser range query also results in the transmission of a LaserPDU (as per DIS V2.0.3 protocol). If the Stealth is attached to a vehicle, the LaserPDU is transmitted on behalf of the vehicle to which the Stealth is attached. Otherwise, the Stealth uses its own entity ID in the LaserPDU. During the Combat-ID experiment, the Stealth was attached to a ModSAF generated vehicle which was used to simulate the vehicle hosting the FO/FAC+ or EFAC system.

Crosshairs representing the direction of the laser range finder appeared on the graphics window as a two-dimensional overlay. In addition, the North-relative heading in degrees was displayed on the graphics window as a textual two-dimensional overlay. This capability could be turned on/off via a command line argument.

User selectable rotational and translational sensitivity for the Spaceball. Buttons 1 and 2 decrease and increase these gains, respectively.

One Stealth, operating on the DIS side of the network, was used in support of the ATG-BCI experiment utilizing a SGI High Indigo2 Impact.

2.4 Terrain Database

The existing ADST II National Training Center terrain database was used to support the ATG-BCI Experiment. The database supports the visual and Infrared spectra. The moving models associated with this database have three Levels of Detail within the rendered scene.

2.5 Scenarios

The experiment simulated offensive and defensive operations by Blue Forces utilizing the National Training Center scenario developed for use in the Task Force XXI Advanced Warfighting Experiment. No additional scenarios were developed specifically for this experiment.

2.6 Legacy

The legacy of the ATG-BCI Experiment is in the software modifications made to represent the new combat identification technologies, and the integration of these systems into the DIS simulations. Copies of the following software modifications in Tables 2 and 3 below are available from the ADST II Library:

Table 2 ATG-BCI Software

SOFTWARE	CM NUMBER
ATG-BCI RWA	MD0139
ATG-BCI FWA	MD0138

Documentation for the ATG-BCI experiment include the following:

Table 3 ATG-BCI Documentation

DOCUMENT	CM NUMBER
Final Report	ADST-II-CDRL - 028R-9600335
ATG-BCI RWA VDD	ADST-II-MISC - 028R-9600360
ATG-BCI FWA VDD	ADST-II-MISC - 028R-9600359
ATG-BCI Support Apps VDD	ADST-II-MISC - 028R-9600380

3. Conduct of the Experiment

3.1 Pilot Training

Pilot Training was conducted at the AVTB the week of 19-23 August 1996. This training included familiarization with the manned simulators and the objectives of the experiment. The training was conducted by the AVTB including familiarization of the ATG-BCI technologies.

3.2 Experimental Trial Runs

The experimental trials were conducted over a period of ten days. The first five days consisted of rotary wing only trials. The remaining five days included combinations of rotary wing, fixed wing, and forward air controller capabilities. Table 4 depicts the trial run matrix used to support the experiment.

Table 4 Experimental Run Matrix

Trial Day	Trial Designator	Trial Number	Comment
1	R1A0	1A1	NO VARIABLES
	R1A1	1A2	RED ADA
	R3D1	1P1	RED ADA
	R3D2	1P2	RED AVN
2	R2D2	2A1	RED AVN
	R2D3	2A2	RED ADA/AVN
	R1A3	2P1	RED ADA/AVN
	R3A1	2P2	RED ADA
3	R2A0	3A1	NV
	R2A1	3A2	RED ADA
	R3A0	3P1	NV
	R1A2	3P2	RED AVN
4	R3D3	4A1	RED ADA/AVN
	R3D0	4A2	NV
	R2D1	4P1	RED ADA
	R2D0	4P2	NV
5	R2A2	5A1	RED AVN
	R3A3	5A2	RED ADA/AVN
	R3D2	5P1	RED AVN
	R2D3	5P2	RED ADA/AVN
6	F1G1R2D0	6A1	NV
	F1G2R3D1	6A2	RED ADA
	F1G3R3A0	6P1	NV
	F2G2R2A2	6P2	RED AVN
7	F2G3R3D3	7A1	RED ADA/AVN
	F2G1R2D1	7A2	RED ADA
	F3G2R2A1	7P1	RED ADA
	F3G1R3A3	7P2	RED ADA/AVN
8	F3G3R3D3	8A1	RED ADA/AVN
	F2G3R2D1	8A2	RED ADA
	F2G2R2A1	8P1	RED ADA
	F3G2R3A2	8P2	RED AVN
9	F3G3R2A2	9A1	RED AVN
	F2G2R2A3	9A2	RED ADA/AVN
	F2G2R3D1	9P1	RED AVN
	F3G3R3D3	9P2	RED ADA/AVN
10	F3G1R3A0	10A1	NV
	F1G1R1A1	10A2	RED ADA
	F2G2R2D3	10P1	RED ADA/AVN
	F3G3R3D3	10P2	RED ADA/AVN

For the trial designators, the following codes in Table 5 depict the trial run.

Table 5 Trial Designators

System	Technology	Scenario	Scenario Variable
R = RWA(AH-64)	1 = Base Case 2 = BCIS Model 2 3 = SINCGARS SIP+	A = Attack D = Defend	0 = None 1 = Red ADA 2 = Red AVN 3 = Red ADA/AVN
G = GFAC	1 = Base Case 2 = EFAC 3 = FOFAC+	A = Attack D = Defend	0 = None 1 = Red ADA 2 = Red AVN 3 = Red ADA/AVN
F = FWA(F-16)	1 = Base Case 2 = SABER 3 = SADL	A = Attack D = Defend	0 = None 1 = Red ADA 2 = Red AVN 3 = Red ADA/AVN

Therefore, for trial day 6 run number 1 of the day (F1G3R2D0), the trial consisted of a Fixed Wing Aircraft utilizing the base case (F1), the GFAC utilizing the FOFAC +(G3), the rotary wing utilizing the BCIS Model 2 (R2) in a defend scenario (D) with no additional red variables other than antitank missiles, small arms and automatic weapons(0).

A total of 40 trial runs were conducted. COLSA Corp provided the experiment director and conducted the operational analysis of the experiment.

4. Observations and Lessons Learned

4.1 Systems Development and Integration

4.1.1 Integration Schedule

- **Observation**

The planned integration period of three days at the AVTB was inadequate for fully integrating and testing the developed systems.

- **Discussion**

The integration period at the AVTB was originally scheduled for a period of three days. During this period, the developed software was installed and initial testing was performed while pilot training was being conducted. The schedule became tight as the setup of the manned simulators and supporting equipment took place simultaneously with training and software installation. An additional two days for integration would have resulted in a smoother transition into testing.

- **Lesson Learned**

Integration must be complete prior to pilot training. In future efforts with limited budgets, the integration period must not be compromised if at all possible.

4.1.2 Maverick Missiles

- **Observation**

During initial trials, the Maverick missiles, operated from the FWA, appeared to malfunction.

- **Discussion**

During the first two trial runs utilizing the FWA, the USAF pilots complained that the Maverick missile did not appear to be responding properly. A review of the engagements revealed that the pilot was operating the missiles outside of the established model parameters of the missile.

- **Lesson Learned**

Additional training may be required to ensure the participants fully understand the limitations of the virtual world systems.

4.1.3 SINGARS Radio Model / SINGARS Radio Emulator

- **Observation**

The SRE worked intermittently throughout the experiment.

- **Discussion**

At the outset of the experiment, the reliability of the SRE was questionable. A decision was made to place the SRE on a separate DIS network in order to reduce PDU traffic. This increased the reliability of the system but did not fully solve the problem. For the length of the experiment, the radios had to be continuously reset. Attempts to isolate the problems in the system were unsuccessful.

- **Lesson Learned**

The SRM/SRE needs to be further developed to provide increased reliability for future experiments.

4.2 Hardware

4.2.1 Supporting Equipment

- **Observation**

An inoperative graphics board on an SGI High Impact presented an initial short-fall of equipment.

- **Discussion**

During the requirements analysis of the experiment, it was decided that the most cost effective method for simulating the C2 Vehicle was through the use of a stealth rather than making modifications of the C2 Vehicle. An SGI High Impact machine was required for the stealth but not identified for the experiment until the integration period. A High Impact was identified and shipped to the site. However the graphics board was inoperative. TASC then shipped a High Impact to the AVTB to meet the requirement.

- **Lesson Learned**

All hardware requirements must be continuously reviewed throughout the experiment and updated as necessary.

5. Conclusion

The Air -to-Ground Battlefield Combat Identification Experiment achieved its objective of identifying the decision making process an aviator or pilot would use while employing varying combat identification technologies. The insights gained from this experiment will allow for the continued development of combat identification tactics, techniques, and procedures for future simulations. Immediate plans call for PM CI to take these insights and employ them in CASTFOREM to continue exploration into the capabilities of these new technologies.

6. References

- Department of the Army, 1996. Air-to-Ground Combat Identification Experiment Plan, prepared by COLSA Corporation for PM-Combat Identification, Fort Monmouth, NJ.
- Department of the Army, 1996. ADST II Statement of Work for Air-To-Ground Battlefield Combat Identification Virtual Experiment Delivery Order Version 2.1, prepared by U.S. Army Simulation, Training and Instrumentation Command, Orlando,
- Department of the Army 1995. Advanced Warfighting Experiment (AWE) Focused Dispatch (FD) Virtual Simulation 1 (VS 1) Experiment Final Report, prepared by Loral ADST Program Office for U.S. Army Simulation, Training and Instrumentation Command, Orlando, FL.

Acronym List

AAR	After Action Review
ADST	Advanced Distributed Simulation Technology
AI	Artificial Intelligence
APC	Armored Personnel Carrier
Ar Co	Armor Company
ATAS	Air-To-Air Stinger
ATG	Air-to-Ground
ATG-BCI	Air-to-Ground Battlefield Comabt Identification
AVTB	Aviation Test Bed
AWE	Advanced Warfighting Experiment
BCIS	Battlefield Combat Identification System
Bde	Brigade
BFV	Bradley Fighting Vehicle
BnTF	Battalion Task Force
C2	Command and Control
C3	Command, Control, and Communications
C3I	Command, Control, Communications and Intelligence
Cdr	Commander
CDRL	Contract Data Requirement List
CGI	Computer Generated Image
Co	Company
COTS	Commercial Off-The-Shelf
DED	Dynamic Effects Database
D.O.	Delivery Order
DIS	Distributed Interactive Simulation
DMA	Defense Mapping Agency
DSM	Don't Shoot me

EBCIS	Enhanced Battlefield Combat Identification System
EFAC	Enhanced Forward Area Controller
EPLRS	Enhanced Position Location Reporting System
FO/FAC +	Forward Observer/Forward Air Controller plus
FOV	Field Of View
FRAGO	Fragmentary Order
FTP	File Transfer Protocol
FWA	Fixed Wing Aircraft
GB	Gigabytes
GFE	Government Furnished Equipment
GUI	Graphical User Interface
IDA	Institute for Defense Analysis
I/O	Input / Output
IPR	In Progress Review
IR	Infrared
LAN	Local Area Network
Ldr	Leader
LOS	Line Of Sight
LRF	Laser Range Finder
MB	Megabyte
MBT	Main Battle Tank
Mhz	Megahertz
ModSAF	Modular Semi-Automated Forces
MOE	Measure Of Effectiveness
MPDD	Multi Purpose Digital Display
NFOV	Narrow Field -Of-View
OPFOR	Opposing Forces
OPORD	Operations Order
OS	Operating System

OSF	Operational Support Facility
OTW	Out-The-Window
PC	Personnel Computer
PDU	Protocol Data Unit
Plt	Platoon
PM	Program Manager
PM-CI	Project Manager-Combat Identification
PVD	Plan View Display
RAM	Random Access Memory
RIU	Radio Interface Unit
RP	Role Player
SABER	Situational Awareness Beacon with Reply
SADL	Situational Awareness Data Link
SAF	Semi-Automated Forces
SCO	Santa Cruz Operating System
SGI	Silicon Graphics, Inc.
SIMNET	Simulation Network
SINGARS	Single Channel Ground and Airborne Radio System
SINGARS SIP+	SINGARS System Improvement Program Plus
SME	Subject Matter Expert
SRE	SINGARS Radio Emulator
SRM	SINGARS Radio Model
STRICOM	(US Army) Simulation Training and Instrumentation Command
TF	Task Force
TIM	Technical Interchange Meeting
TR	Technical Report
TRR	Test Readiness Review
TTP	Tactics, Techniques, and Procedures
UAV	Unmanned Aerial Vehicle

UIO	Universal Input/Output
UTM	Universal Transverse Mercator
VGA	Video Graphics Array
WF	War Fighter
WFOV	Wide Field-Of-View
XCAU	Transmission (Device) - Cell Adaptor Unit