

REPORT DOCUMENTATION PAGEForm Approved
OMB No. 074-0188

Public reporting burden for this collection of information is estimated to average 1 hour per response, including the time for reviewing instructions, searching existing data sources, gathering and maintaining the data needed, and completing and reviewing this collection of information. Send comments regarding this burden estimate or any other aspect of this collection of information, including suggestions for reducing this burden to Washington Headquarters Services, Directorate for Information Operations and Reports, 1215 Jefferson Davis Highway, Suite 1204, Arlington, VA 22202-4302, and to the Office of Management and Budget, Paperwork Reduction Project (0704-0188), Washington, DC 20503

1. AGENCY USE ONLY (Leave blank)

2. REPORT DATE

6 Nov 1996

3. REPORT TYPE AND DATES COVERED

Final

4. TITLE AND SUBTITLE

Countermine Experiment #0016

5. FUNDING NUMBERS

N61339-96-D-0002

6. AUTHOR(S)

7. PERFORMING ORGANIZATION NAME(S) AND ADDRESS(ES)

Lockheed Martin Corporation
Information Systems Co.
12506 Lake Underhill Road
Orlando, FL 32825

8. PERFORMING ORGANIZATION
REPORT NUMBER

ADST-II-CDRL-017R-9600294A

9. SPONSORING / MONITORING AGENCY NAME(S) AND ADDRESS(ES)

NAWCTSD/STRICOM
12350 Research Parkway
Orlando, FL 32826-3224

10. SPONSORING / MONITORING
AGENCY REPORT NUMBER

11. SUPPLEMENTARY NOTES

12a. DISTRIBUTION / AVAILABILITY STATEMENT

A - Approved for public release; distribution unlimited.

12b. DISTRIBUTION CODE

13. ABSTRACT (*Maximum 200 Words*)

The Countermine Experiment (CME) was an exercise conducted at the Mounted Warfare Test Bed at Fort Knox, KY in July 1996. The exercise was sponsored by the Night Vision and Electronic Sensor Directorate (NVESD), Fort Belvoir, VA and the U.S. Army Simulation, Training, and Instrumentation Command (STRICOM), Orlando, FL. The U.S. Army Engineer School (USAES), Fort Leonard Wood, MO, provided the oversight for the experiment in conjunction with the Mounted Maneuver Battle Laboratory (MMBL), Fort Knox, KY. The experiment employed virtual simulation to depict an armor team conducting breaching operations during a deliberate attack. The purpose of the CME was to explore the potential of new landmine detection and neutralization technologies. The new technologies being explored included the Explosive Standoff Minefield Breaching Device (ESMB) the Ground Standoff Minefield Detection System (GSTAMIDS), and the Airborne Standoff Minefield Detection System (ASTAMIDS).

DTIC QUALITY INSPECTED 2

14. SUBJECT TERMS STRICOM; ADST-II; Simulation; Countermine Experiment; CME;

15. NUMBER OF PAGES

31

16. PRICE CODE

17. SECURITY CLASSIFICATION
OF REPORT

UNCLASSIFIED

18. SECURITY CLASSIFICATION
OF THIS PAGE

UNCLASSIFIED

19. SECURITY CLASSIFICATION
OF ABSTRACT

UNCLASSIFIED

20. LIMITATION OF ABSTRACT

UL

**ADVANCED DISTRIBUTED
SIMULATION TECHNOLOGY II
(ADST II)**

Countermine Experiment #0016

CDRL AB01

Final Report



FOR: NAWCTSD/STRICOM
12350 Research Parkway
Orlando, FL 32826-3224
N61339-96-D-0002
DI-MISC-80711

BY: Lockheed Martin Corporation
Martin Marietta Technologies, Inc.
Information Systems Company
12506 Lake Underhill Road
Orlando, FL 32825

Approved for public release; distribution is limited.

19970620 017

1. INTRODUCTION.....	1
1.1 Purpose.....	1
1.2 Contract Overview	1
1.3 Experiment Overview.	1
1.4 Technical Overview	1
2. System Description.....	2
2.1 Mounted Warfare Test Bed.....	2
2.2 Simulated Warfighting Systems	4
2.2.1 Simulated Forces.....	4
2.2.1.1 Comprehensive Mine Simulation (CMS)	4
2.2.1.2 Dial-A-Tank.....	5
2.2.1.3 Explosive Minefield Breaching Device (ESMB).....	5
2.2.1.4 Ground Standoff Minefield Detection System (GSTAMIDS)	5
2.2.1.5 Modular Semi-Automated Forces (ModSAF)	6
2.2.1.6 SINCGARS Radio Model (SRM) / SINCGARS Radio Emulator (SRE) ...	7
2.2.2 Vehicle Simulators.....	8
2.2.2.1 M1 Main Battle Tank (MBT) Simulator.....	8
2.2.2.2 M2 Bradley Fighting Vehicle (BFV) Simulator	10
2.3 Support Systems	10
2.3.1 Cell Adapter Unit (XCAU).....	10
2.3.2 Data Logger	10
2.3.3 Time Stamper.....	11
2.3.4 Stealth System.....	11
2.4 Terrain Database	12
2.5 Scenario Development.....	12
2.6 Visual Model Development	12
2.7 Legacy.....	13
3. Conduct of the Experiment	13
3.1 Pilot Training	13

3.2 Experimental Trial Runs	14
4. Observations and Lessons Learned	16
4.1 Systems Development and Integration	16
4.1.1 Integration Schedule	16
4.1.2 Visual Model Development	17
4.1.3 Minefields	17
4.1.4 FTP at MWTB	17
4.1.5 SINCGARS Radio Model / SINCGARS Radio Emulator	18
4.1.6 Configuration Control	18
4.2 Administration	19
4.2.1 Experiment Schedule	19
4.2.2 Data Collection Forms	19
4.3 ModSAF	19
4.3.1 Lane Markers	19
4.3.2 ModSAF Training	20
4.4 Hardware	20
4.4.1 Manned Simulators	20
4.4.2 Supporting Equipment	20
5. Conclusion.....	21
6. References.....	21

List of Figures

FIGURE 1 COUNTERMINE EXPERIMENT ASSET LAYOUT AT MWTB	2
FIGURE 2 MWTB SIMNET /DIS NETWORK	4

List of Tables

TABLE 1 CME RUNS MATRIX	vi
TABLE 2 ADST II MWTB ASSETS	3
TABLE 3 COUNTERMINE SOFTWARE	13
TABLE 4 COUNTERMINE DOCUMENTATION	13
TABLE 5 EXPERIMENTAL RUN MATRIX	15
TABLE 6 ALTERNATIVES EMPLOYMENT	16

Executive Summary

The Countermine Experiment (CME) was an exercise conducted at the Mounted Warfare Test Bed at Fort Knox, KY in July 1996. The exercise was sponsored by the Night Vision and Electronic Sensor Directorate (NVESD), Fort Belvoir, VA and the U.S. Army Simulation, Training, and Instrumentation Command (STRICOM), Orlando, FL. The U.S. Army Engineer School (USAES), Fort Leonard Wood, MO, provided the oversight for the experiment in conjunction with the Mounted Maneuver Battle Laboratory (MMBL), Fort Knox, KY. The experiment employed virtual simulation to depict an armor team conducting breaching operations during a deliberate attack. The purpose of the CME was to explore the potential of new landmine detection and neutralization technologies. The new technologies being explored included the Explosive Standoff Minefield Breaching Device (ESMB) the Ground Standoff Minefield Detection System (GSTAMIDS), and the Airborne Standoff Minefield Detection System (ASTAMIDS).

The experiment was conducted in two phases. The first phase was conducted at NVESD and consisted of the ASTAMIDS runs which augmented the intel package provided to the soldiers prior to runs where ASTAMIDS was played. The second phase of the experiment was conducted over a period of four weeks and employed a series of four scenarios with varying alternatives based on technologies and threats. The four vignettes for the experiment included the base case using a Armored Vehicle Launched Mine-clearing Line Charge (AVLM), an ESMB alternative, a GSTAMIDS alternative, and a hybrid alternative in which the GSTAMIDS and the ESMB were combined into one vehicle. All the alternatives were run with and without ASTAMIDS data available. The table below shows the runs matrix used during phase two of the experiment.

Table 1 CME Runs Matrix

VIGNETTE		TRIAL 1 (W/O ASTAMIDS)				TRIAL 2 (W/ ASTAMIDS)			
		SCENARIO							
		S1	S2	S3	S4	S1	S2	S3	S4
V1	BASE CASE	1	2	3	4	5	6	7	8
V2	ESMB	9	10	11	12	13	14	15	16
V3	GSTAMIDS	17	18	19	20	21	22	23	24
V4	ESMB & GSTAMIDS COMBINED	25	26	27	28	29	30	31	32

This final report addresses the simulation systems interconnected, the ModSAF modifications, manned simulator modifications, the visual models development, and the lessons learned in support of the Countermine Experiment. Development of the software to support the experiment was conducted at the Operational Support Facility(OSF) in Orlando, FL. These software developments were then integrated into the Mounted Warfare Test Bed (MWTB) for support of the experiment. Visual model development was performed by TASC in San Antonio, TX and subsequently integrated into the manned simulators at the MWTB. This document does not address the performance of the new technologies during the experiment as this analysis is being performed for NVESD by the Institute for Defense Analysis (IDA).

1. INTRODUCTION

1.1 Purpose

The purpose of this final report is to document the Advanced Distributed Simulation Technology II (ADST II) effort which supported the Countermining Experiment and specifically capture experiment configurations, results, observations, and lessons learned. This document does not address the operational effectiveness of the various systems or specific results of the data collected as this effort was conducted as part of a larger activity. Analysis of overall Countermining experiment efforts and results is being performed by the Institute for Defense Analysis (IDA).

1.2 Contract Overview

The Countermining Experiment (CME) was performed as Delivery Order (DO) #0016 under the Lockheed Martin Advanced Distributed Simulation Technology II (ADST II) contract with the U.S. Army Simulation Training and Instrumentation Command (STRICOM).

1.3 Experiment Overview.

The purpose of the CME was to explore the potential of new landmine detection and neutralization technologies. The experiment was conducted in two phases. Phase I, intelligence gathering conducted at NVESD Fort Belvoir VA, used the Airborne Standoff Minefield Detection System (ASTAMIDS) to gather information about threat minefields. The participation of the Lockheed Martin ADST II team during the ASTAMIDS testing was as an observer for continuity between the two phases of the experiment. Phase II of the experiment employed manned M1 and M2 ADST simulators, manned developmental countermining system desktop simulators, and Modular Semi-Automated Forces (ModSAF) to portray an armored company supported by an engineer platoon. ModSAF was also used to portray the threat force.

1.4 Technical Overview

The technical approach to the Countermining Experiment involved integrating several simulations and models to portray an enemy minefield and the detection and neutralization technologies. Development in support of the experiment included ModSAF changes to support plows and rollers, development of a scorched earth model to visually represent the blast effect from the AVLMM and the ESMB explosion, creation of new visual models to support visualization of the new countermining technologies, and integration of the Dial-A-Tank and Comprehensive Mine Simulator (CMS). ModSAF development and changes to the manned simulators were initially developed at the Operational Support Facility (OSF) during the test and development portion. A two week integration period then followed at the Mounted Warfare Test Bed (MWTB) which concluded with a Test Readiness Review briefing. Final fixes were then completed the week prior to the experiment during which

training was conducted for experiment participants. The actual experiment period lasted 4 weeks during which 32 different iterations were run using 4 basic minefield scenarios.

2. System Description

2.1 Mounted Warfare Test Bed

The Mounted Warfare Test Bed (MWTB) at Fort Knox, KY, contains a variety of vehicle simulators, networks, Semi-Automated Forces (SAF) capabilities, displays for monitoring the battlefield, utilities to facilitate execution of exercises, automated data collection capabilities, and a data reduction and analysis subsystem. The MWTB simulation and support platforms used for the Countermine Experiment are depicted in Figure 1. Table 2 lists the ADST II assets, purpose, protocol, war fighters (WF), and role players (RP) in support of the experiment.

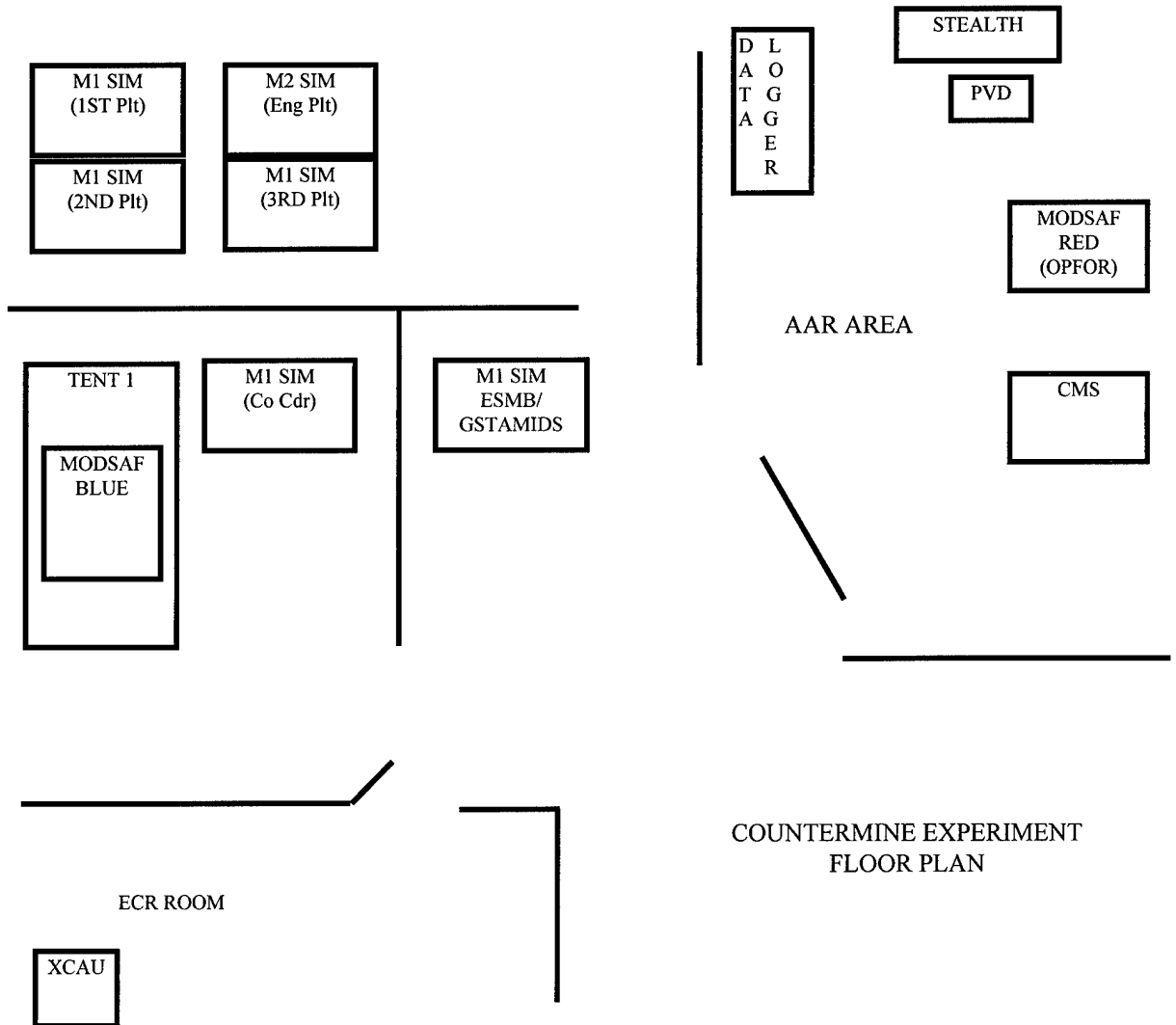

Figure 1 Countermine Experiment Asset Layout at MWTB

The Countermine experiment was conducted using simulation assets interconnected on Ethernet LANs via thin net cable. Some of the simulation assets used support SIMNET protocol while others use the DIS protocol. The following table is a list of simulation assets used at the MWTB.

Table 2 ADST II MWTB Assets

ADST II ASSET	ROLE	PURPOSE	PROTOCOL
M1 Simulator	War Fighter	M1 Manned Simulator	SIMNET
M2 Simulator	War Fighter	M2 Manned Simulator	SIMNET
Stealth	Role Player	Battlefield Display	SIMNET
ModSAF Workstations	Role Player	Semi-Automated Forces	SIMNET and DIS
SINGARS Radio Emulator	Role Player	Radio Communication	DIS
Comprehensive Mine Simulator	Role Player	Minefield Placement and Simulation	DIS
DIAL-A-TANK	Role Player	ESMB/GSTAMIDS simulation	DIS
XCAU		Allows interaction of SIMNET and DIS systems	SIMNET and DIS
Plan View Display		Terrain Map of the battlefield	DIS
Data Loggers		Record DIS PDUS	DIS
DIS Time Stamper		Time Stamp	DIS

Figure 2 depicts the SIMNET and DIS networks in support of the experiment. Thin net ethernet cable was used to connect the systems for both networks.

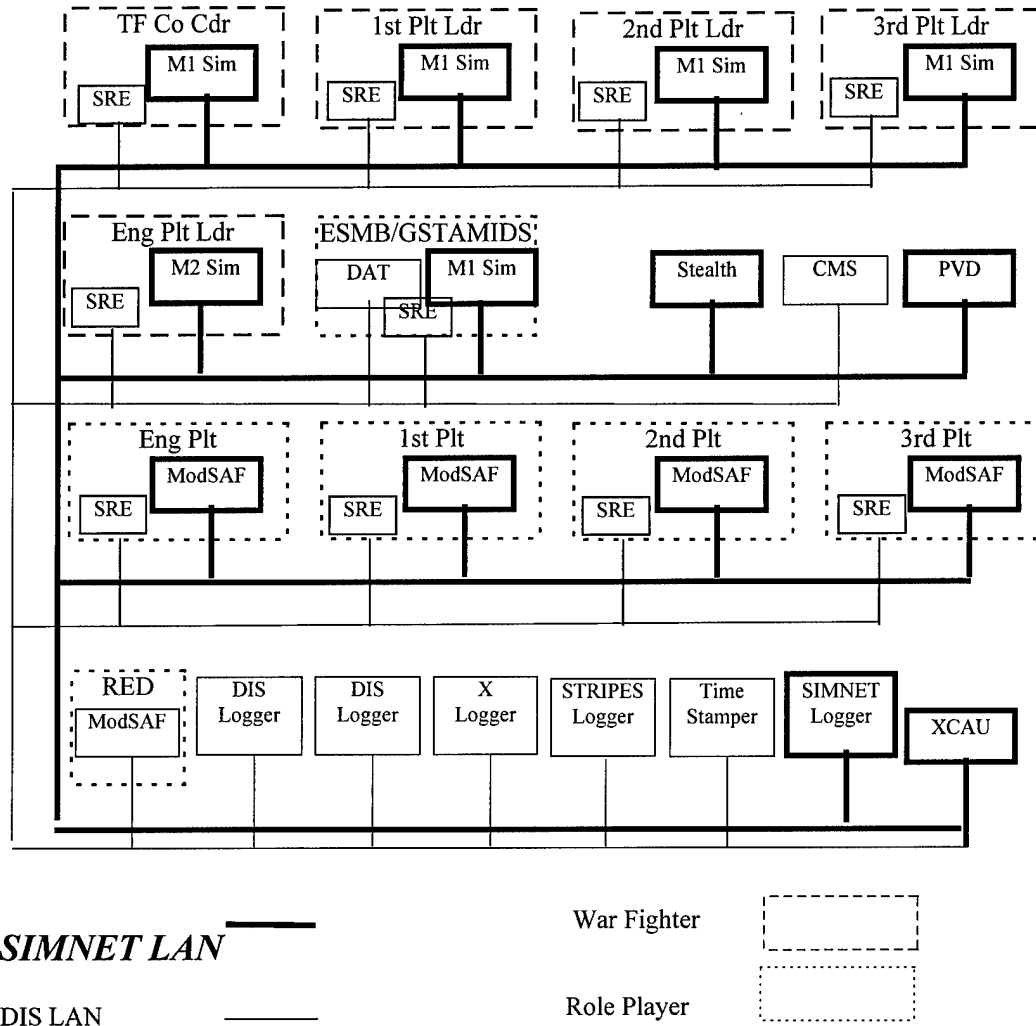

Figure 2 MWTB SIMNET /DIS Network

2.2 Simulated Warfighting Systems

2.2.1 Simulated Forces

2.2.1.1 Comprehensive Mine Simulation (CMS)

The Comprehensive Minefield Simulation provides the ability to emplace doctrinally approved minefields in a DIS environment. The CMS was developed by IDA for NVESD to provide a means to explore emerging technologies in a minefield intensive environment. The simulation supports multiple mine types within a minefield. For the experiment, the OZM-3

pressure fused Antipersonnel Mine, the TM-57 pressure fused Antitank Mine, and the TM-62 tilt-rod fused Antitank Mine types were played. Two experimental PDUs were employed; a minefield PDU and an area detonation PDU. These two PDUs allow for the emplacement of the minefield and supported the sympathetic detonation of the mines as a result of the AVL M and the ESMB detonations. The CMS was hosted on an SGI Indy configured with 96 MB RAM, 1 GB hard drive, and utilized the Irix 5.2 operating system. A copy of the version of CMS used for the experiment is available in the ADST II library.

2.2.1.2 Dial-A-Tank™

Dial-a-Tank™(DAT) is a Commercial Off-The Shelf (COTS) tool for creating and simulating manned vehicles in a Distributed Interactive Simulation environment developed by MÄK Technologies and was provided by NVESD. The Dial-a-Tank software provides two interfaces for creating simulators: the Dial-a-Tank Graphical User Interface (GUI) and the Dial-a-Tank Application Programming Interface. The GUI allows for the construction of DIS Simulators while the Application Programming Interface provides an environment to define new sensors, weapons systems, and components. For the CME, NVESD provided the Dial-A-Tank simulation and the supporting models for the ESMB and GSTAMIDS systems.

2.2.1.3 Explosive Minefield Breaching Device (ESMB)

The ESMB is a minefield clearance device that neutralizes surface and sub-surface land mines regardless of the fusing type of mine. The ESMB uses a system of shape charge devices attached to a rocket-launched net composed of detonation cord. The ESMB system can be vehicle or trailer mounted. The trailer mounted configuration of the ESMB was used for the CME exercise. The ESMB is fired and then subsequently detonated, clearing land mines under the covered area of 5 by 145 meters. For the CME, the ESMB was hosted on a SGI Indy using Dial-A-Tank simulation and attached to the M1 manned simulator as a trailer. The SGI Indy had 128 MB RAM, 1 GB hard drive, and utilized the Irix 5.2 operating system. Inside the manned simulator, the ESMB operator, using a Dell laptop pentium computer, controlled the firing of the ESMB. This configuration was supported by exporting the DISPLAY attributes of the DAT simulator on the SGI to a UNIX window program running on the laptop in the manned simulator, in essence providing the control panel for the ESMB system inside the manned simulator. A DIS detonation PDU is put out at detonation that is translated to a SIMNET PDU via the XCAU resulting in a scorched earth model being deployed on the battlefield.

2.2.1.4 Ground Standoff Minefield Detection System (GSTAMIDS)

The GSTAMIDS is a mine detection system used to identify the leading edge of a minefield. The system uses a suite of complementary sensors to detect magnetic and non magnetic mines in the full-vehicle width path of the host vehicle. The current system is designed to detect anti-tank mines only. The multi-sensor approach combined with the human response time required to react to a detection, limits the operating speed of the system. For the CME, a visual model of the GSTAMIDS was developed and attached to an M1 manned simulator. As with the ESMB, the GSTAMIDS model was hosted on an SGI Indy utilizing Dial-A-Tank simulation. The SGI Indy had 128 MB RAM, 1 GB hard drive, and utilized the Irix 5.2

operating system. The GSTAMIDS operator was located in the M1 manned simulator and utilized a Dell laptop pentium computer. This configuration was supported by exporting the DISPLAY attributes of the DAT simulator on the SGI to a UNIX window program running on the laptop in the manned simulator, in essence providing the control panel for the GSTAMIDS system inside the manned simulator. Information obtained from the GSTAMIDS was then passed to the team commander via SINCGARS radio.

2.2.1.5 Modular Semi-Automated Forces (ModSAF)

The manned simulators used in the Countermine Experiment were augmented by ModSAF vehicles to provide combat arms activities. ModSAF provides the capability to create large numbers of computer generated forces that can be controlled by a small number of operators exercising supervisory control. Battalion level tactical exercises can be performed with only a handful of manned simulators. ModSAF entities can perform opposing, flanking, subordinate, and supporting force roles. The operator controls his forces by issuing Operations Orders (OPORDs) and radio Fragmentary Orders (FRAGOs) that augment the built-in automated reactions of the ModSAF forces. This man-in-the-loop approach provides adaptive opponents without the difficulty and computational expense of full automation.

The ModSAF architecture includes the ModSAF Command Station and Simulator. The SAF workstation provides the graphical user interface from which the operator initializes exercises, observes the battle, and command the SAF. The SAF simulator simulates all the SAF entities, units, and environmental processes. These components are typically run on separate computers distributed over a network.

The SAF workstation allows a user to monitor and control ModSAF forces and to set up exercises. The station provides the user with a two-dimensional electronic map display (Plan View Display) that is used to examine the terrain, monitor the tactical situation, and prepare orders. The workstation does no simulation; it places requests for entities to be simulated and orders to be executed into the Persistent Object (PO) database. The ModSAF simulator accepts these requests and simulates entities carrying put their orders. This division of labor is advantageous, allowing a variety of systems to generate missions for SAF units, including different workstations, Artificial Intelligence programs, as well as other ModSAF simulators.

The ModSAF components employed at the MWTB in support of the Countermine Experiment consisted of five SGI Indy workstations with 96 MB RAM, 150 Mhz, 1 gigabyte hard drive, utilizing the Irix 5.2 operating system. To support the CME, ModSAF development/changes included:

a. Addition of the following ModSAF entity types:

- Vehicle_US_M1A1_PLOW
- Vehicle_US_M1A1_ROLL
- Vehicle_US_M1_VMMD
- Vehicle_US_M1_ESMB
- Vehicle_US_M1_VMMD_ESMB
- Vehicle_US_ESMB_TRAILER

-
- Structure_Scorched_Earth
 - Munition_US_ESMB.
- b. Development of a new library (libscorcheearth) to support the creation of scorched earth when an ESMB Detonation PDU is received.
 - c. Modification of library (libmiclic) to create scorched earth when a line charge is detonated.
 - d. Modification of library (libpduproc) to allow determination of running ModSAF in SIMNET or DIS.
 - e. Modification of library (libcollision) to allow ModSAF entities to ignore collisions with scorched earth.
 - f. Modification of library (libvterrain) to allow routes to cross scorched earth entities.
 - g. Modification of mine damage datafiles to reflect data provided by the Army School of Engineers.
 - h. Modification of library (libplow) to have tank main gun positioned off the side of the tank when in a plowing operation.
 - i. Addition of a new anti-personnel mine definition to damage tables to prevent AP mines from destroying ModSAF tanks.
 - j. Addition of icons for new vehicles listed in "a" above (libpvd).
 - k. Addition of vehicle_US_M1A1_PLOW and vehicle_US_M1A1_ROLL to the Graphical User Interface.

A copy of the CME version of ModSAF is available in the ADST II Library. An associated Version Description Document (VDD) details the changes to the CME ModSAF from the baseline.

2.2.1.6 SINGARS Radio Model (SRM) / SINGARS Radio Emulator (SRE)

The simulation of the SINGARS radio provided the means of communications between the players. The SRM and the SRE are ADST II program assets that simulate realistic propagation effects consistent with the performance that a user could expect from the actual SINGARS system in a real-world application. They are capable of transmitting/receiving voice and data messages from other SRMs/SREs.

The SRE is a hardware/software system that contains the SRM radio core software model. The SRE is based on the SINGARS / Combined Arms Command and Control (CAC2) simulator. The SRE provides a realistic SINGARS user interface, input/output system, and intercom communications.

The SRM uses a probabilistic approach to simulate random errors occurring in the transmitted data. Using a statistical model of the Bit Error Rate (BER), the SRM introduces random errors into data sets received through signal PDUs. The error rate is dependent upon signal to noise ratio and varies with signal frequency and locations of both the received signal

source and interference. Factors in this model that determine Signal-to-noise Ratio are propagation loss effects, interference, and background noise.

The DIS network interface allows the radio to communicate to other radios using DIS v2.03 Standard Transmitter and Signal PDUs. The network interface monitors Entity State PDUs to determine the own-vehicle radio's antenna location and vehicle status.

For the CME, nine (9) ADST (or MWTB) SINCGARS Radio Emulators were used. These models were hosted on an SGI Indy with 96MB RAM, 1 GB hard drive, utilizing the Irix 5.2 operating system.

2.2.2 Vehicle Simulators

2.2.2.1 M1 Main Battle Tank (MBT) Simulator

The ADST M1 tank simulation is a real-time simulation of the M1 Abrams MBT. The simulator consists of two compartments, one of which simulates the turret compartment of the Abrams tank. The second simulates the driver's compartment of the M1 tank. The compartments are linked by communication paths that provide voice communications between crew members and data communications between shared computer resources. All simulated vision devices within the simulator compartments are controlled by a Computer Image Generator (CIG).

The simulated sensors include the vision blocks at the commander, driver, and loader stations, and the Gunner's Primary Sight (GPS) with separate Wide Field-Of-View (WFOV) and Narrow Field-Of-View (NFOV) modes. The simulated GPS includes a dual Field-Of-View (FOV) day vision and a dual FOV Thermal Imaging System (TIS).

GPS and turret stabilization are simulated in the M1 Abrams simulator. Gun and turret movements are controlled by manipulation of the gunner's and/or commander's palm switch and control handles. Slew rates in the M1 simulator for turret azimuth and main gun elevation are consistent with M1 Abrams values.

The M1 simulator includes a ballistic computer simulation. The ballistic computer simulation performs two basic functions. The first function is to elevate the main gun, by the proper amount, to send the projectile to the target range. The second function is to automatically set the proper amount of lead angle to enable the gunner to hit a moving target being tracked at a constant rate.

Vulnerability is simulated in the M1 simulator as combat damage assessment performed when the simulated vehicle receives hit information from a direct fire source or an indirect fire source on the network. Vulnerability assessment is a function of round type, location of hit, range of weapon from the impact point, range from center of the impact (for indirect rounds), and incidence angle of the incoming round. These data are used in conjunction with standard vulnerability information for the M1 to determine the probabilities of Mobility, Firepower, Mobility-and-Firepower and Catastrophic kills for the simulator. These probabilities are used to determine the damage to the simulator.

Time critical mission parameters are accounted for in the M1 simulator explicitly or implicitly. Many of the critical issues simulated in the M1 simulator are:

- a. Battery charge/recharge times.
- b. Fuel consumption rate as a function of engine speed.
- c. Fuel transfer rates between internal tanks.
- d. Fuel resupply rates.
- e. Main gun loading sequence.
- f. Ammunition transfer rates between stowage compartments.
- g. Ammunition transfer times between vehicles.
- h. Turret and main gun slew and elevation rates.

Mobility characteristics are extensively simulated in the M1 simulator. The M1 is powered by an AGT-1500 engine driving an X1100-3B transmission. Fuel consumption, steering, and braking are capabilities that are implemented within the transmission simulation. Hull kinematics and turret dynamics are simulated by transformations applied to a set of vehicle component coordinate systems. These coordinate systems are linked to the world coordinate system standards implemented in the supporting simulation network architecture. Mobility and stability information derived from this simulation segment is fed into other simulation elements, such as delivery accuracy and vulnerability.

The interior of the turret, including commander, loader, gunner and the driver stations in the M1 simulator are reasonable facsimiles of the M1 Abrams, insofar as the relation location and appearance of instrument, instrumentation, and controls used to maneuver and fight the vehicle are concerned.

To support the Countermine Experiment, the following changes to the M1 software code were made:

- a. Modification of damage tables to reflect mine damage tables provided by USAES.
- b. Modification of collision avoidance algorithm to permit transversing of scorched earth.
- c. Modification of terrain analysis algorithm to permit fording of rivers. (Note: M1s may ford rivers, however, ModSAF vehicles cannot ford rivers.)
- d. Modification of vehicle mapping file to add CME vehicles.
- e. Modification of ammunition mapping file to accommodate CME effects.

Five MWTB M1 simulators were used for the Countermine Experiment. A copy of the CME version of the M1 software is available in the ADST II Library. An associated Version Description Document (VDD) details the changes to the CME M1 from the baseline.

2.2.2.2 M2 Bradley Fighting Vehicle (BFV) Simulator

Like the M1 simulator, the M2 simulator is a real-time simulation of the M2 BFV. The simulator consists of two compartments, one of which simulates the turret compartment of the BFV, the second simulates the driver's compartment of the BFV. The compartments are linked by communications paths that provide voice communications between crew members and data communications between shared computer resources. All simulated vision devices within the simulator compartments are controlled by a Computer Image Generator.

For the Countermine Experiment, the M2 BFV played the role of the Engineer Platoon Leader's vehicle. The graphical depiction of the M2 BFV for this exercise was as an M113 Armored Personnel Carrier (APC) in order to correlate with the Table Of Equipment (TOE) for an engineer platoon. To support the Countermine Experiment, the following changes to the M2 software code were made:

- a. Modification of damage tables to reflect mine damage tables provided by USAES.
- b. Modification of collision avoidance algorithm to permit transversing of scorched earth.
- c. Modification of terrain analysis algorithm to permit fording of rivers.
- d. Modification of vehicle mapping file to add CME vehicles.
- e. Modification of ammunition mapping file to accommodate CME effects.

One MWTB M2 simulator was used for the Countermine Experiment. A copy of the CME version of the M2 software is available in the ADST II Library. An associated Version Description Document (VDD) details the changes to the CME M2 from the baseline.

2.3 Support Systems

2.3.1 Cell Adapter Unit (XCAU)

The XCAU consists of a workstation and associated software that allows DIS network protocol simulators to interoperate with SIMNET protocol simulators within the constraints of translated PDUs. The XCAU provides two parallel protocol translation processes: translation of DIS to SIMNET, and SIMNET to DIS. No software changes were made to the XCAU in support of the CME. The host system for the XCAU was an SGI Indigo 2 with 128 MB RAM, 2 GB hard drive, utilizing the Irix 5.2 Operating System.

2.3.2 Data Logger

The Data Logger is an ADST II asset that captures the network traffic and places the data packets in a file to be used later for playback and analysis. The Data Logger performs the following functions:

- a. Packet Recording - Receives packets from the DIS or SIMNET network, time stamps and then writes to a disk or tape.

-
- b. Packet Playback - Packets from a recorded exercise can be transmitted in real time or faster than real time. The Data Logger can also suspend playback (freeze time) and skip backward or forward to a designated point in time. The logger can be controlled directly from the keyboard or remotely from the PVD. Playback is visible to any device on the network (PVD, Stealth Vehicle, a vehicle simulator, etc.).
 - c. Copying or Converting - Files are copied to another file, which can be on the same or a different medium; and files from the older version of the Data Logger can be converted to a format compatible with the current version of the Data Logger.

For the Countermine Experiment, a series of five data loggers were employed to capture the exercise. On the DIS network, two data loggers were used to capture the standard output data for analysis. These two loggers used Sun IPX systems with 48 MB RAM, 1 GB Hard drive, utilizing the Sun operating system (OS) OS 4.1.3.

In addition, a STRIPES data logger and X-logger were placed on the DIS network to facilitate the capturing of Comprehensive Mine Simulator data and Persistent Object (PO) PDUs. These two loggers were hosted on SGI Indys with 96 MB RAM, 1 GB hard drive, utilizing the Irix 5.2 operating system. A SIMNET logger was also employed to capture information on the SIMNET side.

2.3.3 Time Stamper

The ADST II time stamper consisted of a video time code generator, which produced time data in days-since -1 Jan 1970 in a /hour/min/sec format, and was hosted by an IBM-compatible Personal Computer (PC). The PC was programmed to read the video time code, convert the time data, and then generate a Time PDU, which was then issued on the DIS network each second. This provided the real world clock time on the logged data to assist in subsequent analyses.

2.3.4 Stealth System

The ADST II Stealth gives the Observer/Controller (O/C) personnel a "window" into the virtual battlefield, allowing them to make covert observations of the action occurring during the scenario. In addition, through the use of the data logger, the Stealth gives observers and analysts an After Action Review (AAR) capability. The Stealth is a visual display platform that consists of a PVD, various input devices, and three video displays that provide the operator with a panoramic view of the battlefield.

The Stealth permits the controller to fly around the virtual battlefield and view the simulation without interfering with the action. The features of the Stealth allow the observer to survey the virtual battlefield from a variety of different perspectives, including:

- a. Tethered View - Allows the user to attach unnoticed to any vehicle on the virtual battlefield.
- b. Mimic View - Places the user in any vehicle on the virtual battlefield and provides the same view as the vehicle commander.

-
- c. Orbit View - Allows the operator to remain attached to any vehicle on the virtual battlefield and to rotate 360° about that vehicle, while still maintaining the vehicle as a center point of view.
 - d. Free Fly Mode - Permits independent 3-D movement anywhere in the virtual battlefield.

One MWTB Stealth, operating on the SIMNET side of the network, was used in support of the Countermine Experiment utilizing a GT 111 image generator. The vehicle mapping file and the ammunition mapping file for the Stealth were modified to support the CME visual models.

2.4 Terrain Database

The existing ADST II Fort Knox terrain database was used to support the Countermine Experiment. The Fort Knox database supports the visual and Infrared spectra. The moving models associated with this database have three Levels of Detail.

2.5 Scenario Development

A series of four test and one training scenarios were developed to support the Countermine Experiment. The scenarios depicted a Company Team conducting a deliberate attack operation. The scenarios included operations orders for the Battalion task force and Fragmentary Orders (FRAGOs) for the conduct of the mission. Overlays to support the scenarios were developed and provided for the conduct of the exercise.

2.6 Visual Model Development

A series of visual models to support the Countermine Experiment were developed. These models, developed by TASC, include the following:

- a. ESMB trailer model.
- b. ESMB flyout model.
- c. GSTAMIDS model.
- d. Scorched Earth model.
- e. Plow.
- f. Roller.
- g. AVLM (MICLIC).

These models were developed utilizing the S1000 development tool and provided as a Dynamic Effects Database (DED) file. Alterations were made to the manned simulators vehicle mapping files and ammunition mapping files to support the additional models.

2.7 Legacy

The legacy of the Countermine Experiment is in the software modifications made to represent the new countermine technologies, new visual models to support their effects, ModSAF development, and the integration of the varying simulations. Copies of the following software are available from the ADST II Library:

Table 3 Countermine Software

SOFTWARE	CM NUMBER
Comprehensive Minefield Simulation (CMS)	MD0093
CME M1 1.0	MD0098
CME M2 1.0	MD0099
CME ModSAF 1.0	MD0090

Version Description Documents (VDD) are available for ModSAF, M1, and M2 reflecting the modifications. Additional information about the Comprehensive Minefield Simulation is available through NVESD.

Table 4 Countermine Documentation

DOCUMENT	CM NUMBER
Test Readiness Review	ADST-II-CDRL-026R-9600201
Final Report	ADST-II-CDRL-017R-9600294
Experiment Plan	ADST-II-MISC-017R-9600320
CME ModSAF 1.0 VDD	ADST-II-CDRL-017R-9600329
CME M1 1.0 VDD	ADST-II-CDRL-017R-9600330
CME M2 1.0 VDD	ADST-II-CDRL-017R-9600331

3. Conduct of the Experiment

3.1 Pilot Training

Pilot Training was conducted at the MWTB the week of 24-28 June 1996. This training included familiarization with the manned simulators, familiarization with breaching

operations to include the new Countermine technology and the objectives of the experiment. Days one and two for the training week focused on individual training (driver and tank commander) and becoming familiar with the driving and operations of the simulators. The Battlemaster from the MWTB served as the director for the training and familiarization. USAES presented classes on tactics, techniques, and procedures for breaching operations and employment of the ESMB, GSTAMIDS, AVL M, Track Width Mine Plows and Rollers. NVESD presented training to the troops on the technical aspects of the developmental countermine system participating, and provided guidance to the research assistants for manual data collection procedures. Days three and four of the pilot training focused on collective unit tasks. A training scenario, developed by MWTB, was used to practice procedures for conducting a deliberate attack and breaching minefields. Day five of the training concluded with a final test run of the base case using the training scenario. Several delays during pilot training occurred due to equipment problems and integration being incomplete. The Experiment Director, at the conclusion of the pilot testing, directed that the first day of the experiment would be an additional training day and the start of runs for the experiment would be delayed one day.

3.2 Experimental Trial Runs

The trial runs for the experiment began 9 July 1996 and finished on 2 August 1996. A total of 32 runs for the varying alternatives were conducted. Two runs were planned for each day with day five of each week being available for reruns as required. Four (4) runs (1 - 4) were required to be performed a second time once it had been determined that the direct fire engagements between red and blue ModSAF vehicles were not working properly. The run matrix for the experiment is at Table 5.

Table 5 Experimental Run Matrix

	Monday	Tuesday	Wednesday	Thursday	Friday
Week 1 AM	Practice Run	* Base Case Scen1 No ASTAMIDS	* Base Case Scen3 No ASTAMIDS	Base Case Scen1 ASTAMIDS	Base Case Scen3 ASTAMIDS
Week 1 PM	Practice Run	* Base Case Scen2 No ASTAMIDS	* Base Case Scen4 Base Case Scen2 No ASTAMIDS	Base Case Scen2 ASTAMIDS	Base Case Scen4 ASTAMIDS
Week 2 AM	ESMB Scen1 No ASTAMIDS	ESMB Scen3 No ASTAMIDS	ESMB Scen1 ASTAMIDS	ESMB Scen3 ASTAMIDS	
Week 2 PM	ESMB Scen2 No ASTAMIDS	ESMB Scen4 No ASTAMIDS	ESMB Scen2 ASTAMIDS	ESMB Scen4 ASTAMIDS	
Week 3 AM	GSTAMIDS Scen1 No ASTAMIDS	GSTAMIDS Scen3 No ASTAMIDS	GSTAMIDS Scen1 ASTAMIDS	GSTAMIDS Scen3 ASTAMIDS	
Week 3 PM	GSTAMIDS Scen2 No ASTAMIDS	GSTAMIDS Scen4 No ASTAMIDS	GSTAMIDS Scen2 ASTAMIDS	GSTAMIDS Scen4 ASTAMIDS	
Week 4 AM	Combo Scen1 No ASTAMIDS	Combo Scen3 No ASTAMIDS	Combo Scen1 ASTAMIDS	Combo Scen3 ASTAMIDS	
Week 4 PM	Combo Scen2 No ASTAMIDS	Combo Scen4 No ASTAMIDS	Combo Scen2 ASTAMIDS	Combo Scen4 ASTAMIDS	

* - Indicates runs which had to be re-run.

Four scenarios were used with varying amounts of intelligence data provided. During the No ASTAMIDS trials, the team commander was provided with an operations order and a standard intelligence estimate of the situation. For the ASTAMIDS runs, the commander was provided with an additional intelligence overlay depicting the information obtained from the ASTAMIDS vehicle.

The four vignettes for the experiment which varied by equipment mix, the developmental systems (VIGNETTE 2 - 4) participated via M1A1 manned simulator and the base case

(VIGNETTE 1) used a ModSAF simulator to provide the participation of the AVLMM. Table 6 depicts the alternative and the associated method of employment.

Table 6 Alternatives Employment

Alternative	Platform	Operator
Base Case (AVLMM)	ModSAF	ModSAF RP
ESMB	M1 manned sim	NVESD RP
GSTAMIDS	M1 manned sim	NVESD RP
ESMB-GSTAMIDS	M1 manned sim	NVESD RP

All experimental trials were completed by the final day (2 August 1996) of the experiment. Analysis of the operational performance and the decision making process of the warfighters was conducted by IDA.

4. Observations and Lessons Learned

4.1 Systems Development and Integration

4.1.1 Integration Schedule

- **Observation**

Integration period at the MWTB was not completed as scheduled.

- **Discussion**

The integration period at the MWTB was originally scheduled for a period of two weeks (10 - 21 June). During this period, the CME hardware setup was completed and ModSAF integration continued from the work previously completed at the OSF. The visual models were originally scheduled for delivery at the MWTB during the beginning of the second week of integration. However, a delay in delivery of one week caused the integration schedule to continue for a third week. A compounding problem delaying integration was the CMS, ESMB, and GSTAMIDS models being integrated during the start of training (24-28 June). Training and integration can not be completed simultaneously.

- **Lesson Learned**

Integration must be complete prior to pilot training. Use of the OSF to perform integration testing was ineffective due to the fact that MWTB manned simulators, CMS and desktop simulators were not exposed to the actual exercise environment until late in the integration phase. This did not allow sufficient time to identify and correct problems which occurred when all systems were present until the pilot tests. All participants must be present during the integration effort and critical path delivery items must be met. During integration,

configuration control and regression testing are essential to avoid confusion and maintain efficient use of assets.

4.1.2 Visual Model Development

- **Observation**

Initial integration of the visual models into the manned simulators caused numerous visual problems.

- **Discussion**

The DED file developed for the CME contained varying guise numbers for the associated models. Initial use of the DED resulted in the appearance of "beach balls" indicating an incorrect mapping in the vehicle mapping file for the manned simulators. These problems were subsequently identified and the vehicle mapping file and ammunition mapping file were changed to reflect the new DED.

- **Lesson Learned**

Early delivery of the new visual models with an in-depth description of the associated guise numbers is necessary to incorporate the information into the vehicle mapping file and the ammunition mapping file.

4.1.3 Minefields

- **Observation**

Antipersonnel mines initially destroyed hard targets such as tanks.

- **Discussion**

The OZM-3 Antipersonnel mine destroyed the M1 tank when it entered the minefield. A review of the data enumeration's table indicated that the effect should have no damage. After researching the problem, it was determined that the PDU from CMS had been modified and was for a different version of ModSAF. The PDU was changed back to the previous version and the problem was alleviated.

- **Lesson Learned**

Coordination and configuration management must be maintained throughout the integration process.

4.1.4 File Transfer Protocol (FTP) at MWTB

- **Observation**

FTP capability at the MWTB was not configured for use at the beginning of the integration period.

- **Discussion**

The ability to FTP between the developers home site (OSF) and the testbed is necessary to support integration and development. Lockheed Martin and NVESD had requirements to FTP files into and out of the MWTB. A circuitous route was initially setup to allow for FTP between the OSF and the MWTB. This meant that users had to have their home stations FTP into the OSF and then from the OSF to the MWTB. This greatly inhibited the integration

effort. Eventually, FTP capability was established to allow NVESD to transfer files with their home site.

- **Lesson Learned**

FTP must be available continuously throughout the integration period and the experiment.

4.1.5 SINCGARS Radio Model / SINCGARS Radio Emulator

- **Observation**

The SRE worked intermittently throughout the experiment.

- **Discussion**

At the outset of the experiment, the reliability of the SRE was questionable. A decision was made to place the SRE on a separate DIS network in order to reduce PDU traffic. This increased the reliability of the system but did not fully solve the problem. For the length of the experiment, the radios had to be continuously reset. Attempts to isolate the problems in the system were unsuccessful.

- **Lesson Learned**

The SRM/SRE needs to be further developed to provide increased reliability for future experiments.

4.1.6 Configuration Control

- **Observation**

Data enumeration's and PDUs changed continuously throughout the development and integration effort.

- **Discussion**

The PDUs for the minefields and the data enumeration's were in a constant state of change during the development. The PDUs for the minefields were changed and not coordinated among the developers. This caused delays in development in ModSAF, CMS, and the manned simulators. Developers were unable to test their changes with the dynamic aspects of the integration period. Software changes to ModSAF and other CME software were made without the Lead Systems Engineers knowledge, which at times caused anomalies to occur within the system.

- **Lesson Learned**

One individual must serve as the lead and approval authority for all changes during the integration period and the experiment. All changes to the software and hardware setups must be approved prior to implementation. This individual may be either the Lead Systems Engineer or the Experiment Director. A regression/retest checklist should be executed after changes occur to verify system stability.

4.2 Administration

4.2.1 Experiment Schedule

- **Observation**

Do not schedule a systems "fix" week during a holiday period.

- **Discussion**

The integration schedule called for system "fixes" to be implemented the week of 1 - 5 July. The holiday schedule reduced the work week period to three days for fixes.

- **Lesson Learned**

Schedule must account for holiday periods without compromising the experiment.

4.2.2 Data Collection Forms

- **Observation**

Manual data collection forms were not initially tailored well to the experiment.

- **Discussion**

The initial forms for data collection were generic in nature and did not focus in-depth on the objectives of the Countermine Experiment. The Research Assistants working in conjunction with NVESD adapted the data collection to make them more user friendly while focusing on the objectives of the experiment.

- **Lesson Learned**

Utilize the experience of the Research Assistants early on for development of manual data collection forms tailored to an experiment.

4.3 ModSAF

4.3.1 Lane Markers

- **Observation**

ModSAF was unable to handle duel marked breach lanes.

- **Discussion**

Based on the doctrinal situation, there were times when the ModSAF operators needed to plow scorched earth and place lane markers. ModSAF vehicles viewed this as two separate lanes and in some instances would become "confused" and exhibit an inability to move through the marked lane.

- **Lesson Learned**

ModSAF should be modified to respond to the operator regardless of how many lanes exist on the database.

4.3.2 ModSAF Training

- **Observation**

Not enough training time was allocated for the ModSAF operators to become completely familiar with the version of ModSAF used to support CME (v2.1).

- **Discussion**

A new version of ModSAF was released coinciding with the start of the experiment. The ModSAF operators for the exercise were trained on the new version one week prior to the commencement of the experiment. The result was the operators were learning ModSAF 2.1 while training of the soldiers was taking place. This led to several errors as to what the capabilities of ModSAF were.

- **Lesson Learned**

ModSAF operators must be trained prior to the experiment if a new version is to be used.

4.4 Hardware

4.4.1 Manned Simulators

- **Observation**

The M1s experienced two hard drive failures during the experiment.

- **Discussion**

The two hard drive failures caused temporary delays during the experiment. The drives were replaced and the software reloaded.

- **Lesson Learned**

Some hardware down time should be planned for in the development of the experiment schedule.

- **Observation**

M2 experienced visual system problems throughout the test.

- **Discussion**

The tank Commander was able to see all vehicles (ModSAF and manned simulators) however the driver saw vehicles intermittently. During breaching operations, the driver's view returned to normal and he was able to traverse the scorched earth. This problem appeared to be a hardware limitation of the GT 111.

- **Lesson Learned**

The hardware limitations of the Level 1 CIGs limits the details of an experiment.

4.4.2 Supporting Equipment

- **Observation**

SGI Indy hosting the CMS experienced a failure during the experiment.

- **Discussion**

The SGI Indy was replaced and the software reloaded. A small amount of down time was experienced.

- **Lesson Learned**

Some hardware down time should be planned for in the development of the experiment schedule.

5. Conclusion

The Countermine Experiment achieved its objective of identifying the decision making process a unit commander would use in employing new minefield detection and clearing technologies. The insights gained from this experiment will allow for the continued development of countermine tactics, techniques, and procedures for future simulations. Immediate plans call for NVESD to take these insights and employ them in CASTFOREM to continue exploration into the capabilities of these new technologies.

6. References

Department of the Army, 1996. Countermine Experiment Plan, prepared by U.S. Army Engineer School Engineer Force Simulation Center, Fort Leonard, MO.

Department of the Army, 1996. ADST II Statement of Work for Countermine Experiment, prepared by U.S. Army Simulation, Training and Instrumentation Command, Orlando,

Department of the Army 1995. Advanced Warfighting Experiment (AWE) Focused Dispatch (FD) Virtual Simulation 1 (VS 1) Experiment Final Report, prepared by Loral ADST Program Office for U.S. Army Simulation, Training and Instrumentation Command, Orlando, FL.

Acronym List

AAR	After Action Review
ADST	Advanced Distributed Simulation Technology
APC	Armored Personnel Carrier
ASTAMIDS	Airborne Standoff Minefield Detection System
AVLM	Armored Vehicle Launched Mine-clearing Line Charge (MICLIC)
AWE	Advanced Warfighting Experiment
BER	Bit Error Rate
BFV	Bradley Fighting Vehicle
CAC2	Combined Arms Command and Control
Cdr	Commander
CDRL	Contract Data Requirement List
CIG	Computer Image Generator
CME	Countermine Experiment
CMS	Comprehensive Minefield Simulation
Co	Company
COTS	Commercial Off-The-Shelf
DAT	Dial-A-Tank
DED	Dynamic Effects Database
DO	Delivery Order
DIS	Distributed Interactive Simulation
Eng	Engineer
ESMB	Explosive Standoff Minefield Breacher
FD	Focused Dispatch
FOV	Field Of View
FRAGO	Fragmentary Order
FTP	File Transfer Protocol
GB	Gigabytes
GPS	Gunners Primary Sight

GSTAMIDS	Ground Standoff Minefield Detection System
GUI	Graphical User Interface
IDA	Institute for Defense Analysis
I/O	Input / Output
LAN	Local Area Network
Ldr	Leader
LOS	Line Of Sight
M1	Version of the Abrams Main Battle Tank
M2BFV	Version of the Bradley Fighting Vehicle
MB	Megabyte
MBT	Main Battle Tank
Mhz	Megahertz
MICLIC	Mine-clearing Line Charge
MMBL	Mounted Maneuver Battle Laboratory
ModSAF	Modular Semi-Automated Forces
MWTB	Mounted Warfare Test Bed
NFOV	Narrow Field -Of-View
NVESD	Night Vision and Electronic Sensor Directorate
O/C	Operator/Controller
OPFOR	Opposing Forces
OPORD	Operations Order
OS	Operating System
OSF	Operational Support Facility
OTW	Out-The-Window
PC	Personnel Computer
PDU	Protocol Data Unit
Plt	Platoon
PVD	Plan View Display
PO	Persistent Objective

RAM	Random Access Memory
RP	Role Player
SAF	Semi-Automated Forces
SGI	Silicon Graphics, Inc.
SIMNET	Simulation Network
SINGARS	Single Channel Ground and Airborne Radio System
SRE	SINGARS Radio Emulator
SRM	SINGARS Radio Model
STRICOM	(US Army) Simulation Training and Instrumentation Command
TC	Tank Commander
TF	Task Force
TIM	Technical Interchange Meeting
TIS	Thermal Imaging System
TOE	Table Of Equipment
USAES	United States Army Engineer School
UTM	Universal Transverse Mercator
VDD	Version Description Document
VMMD	Vehicle Mounted Mine Detector
WF	War Fighter
WFOV	Wide Field-Of-View
XCAU	Transmission (Device) - Cell Adapter Unit