

**UNITED STATES AIR FORCE
ARMSTRONG LABORATORY**

**Three-Dimensional Numerical Modeling
of Groundwater Flow in the Vicinity of
Funnel-and-Gate Systems**

Steve Shikazi, University of Waterloo

for

**APPLIED RESEARCH ASSOCIATES, INC.
4300 San Mateo Boulevard, NE, Suite A220
Albuquerque, New Mexico 87110**

May 1997

19970707 019

DTIC QUALITY INSPECTED 8

Approved for public release; distribution is unlimited.

**Environnics Directorate
Environmental Risk
Management Division
139 Barnes Drive
Tyndall Air Force Base FL
32403-5323**

NOTICES

This report was prepared as an account of work sponsored by an agency of the United States Government. Neither the United States Government nor any agency thereof, nor any employees make any warranty, expressed or implied, or assume any legal liability or responsibility for the accuracy, completeness, or usefulness or any privately owned rights. Reference herein to any specific commercial process, or service by trade name, trademark, manufacturer, or otherwise does not necessarily constitute or imply its endorsement, recommendation, or favoring by the United States Government or any agency, contractor, or subcontractor thereof. The views and opinions of the authors expressed herein do not necessarily state or reflect those of the United States Government or any agency, contractor, or subcontractor thereof.

When Government drawings, specifications, or other data are used for any purpose other than in connection with a definitely Government-related procurement, the United States Government incurs no responsibility or any obligations, whatsoever. The fact that the Government may have formulated or in any way supplies the said drawings, specifications, or other data, is not to be regarded by implication, or otherwise in any manner construed, as licensing the holder or any person or corporation; or as conveying any rights or permission to manufacture, use or sell any patented invention that may in any way be related thereto.

This technical report has been reviewed by the Public Affairs Office (PA) and is releasable to the National Technical Information Service, where it will be available to the general public, including foreign nationals.

This report has been reviewed and is approved for publication.

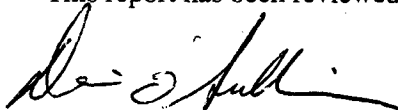

DENNIS O'SULLIVAN, Lt, USAF, BSC
Project Officer



ALLAN M. WEINER, Lt Col, USAF
Chief, Environmental Risk Management Division

REPORT DOCUMENTATION PAGE

Form Approved
OMB No. 0704-0188

Public reporting burden for this collection of information is estimated to average 1 hour per response, including the time for reviewing instructions, searching existing data sources, gathering and maintaining the data needed, and completing and reviewing the collection of information. Send comments regarding this burden estimate or any other aspect of this collection of information, including suggestions for reducing this burden, to Washington Headquarters Services, Directorate for Information Operations and Reports, 1215 Jefferson Davis Highway, Suite 1204, Arlington, VA 22202-4203, and to the Office of Management and Budget, Paperwork Reduction *Project (0704-0188), Washington, DC 20503.

1. AGENCY USE ONLY (Leave blank)		2. REPORT DATE April 1997	3. REPORT TYPE AND DATES COVERED Final Report July 1995 to April 1997	
4. TITLE AND SUBTITLE 3D Numerical Modeling of Groundwater Flow in the Vicinity of Funnel-and-Gate Systems			5. FUNDING NUMBERS F08635-93-C-0020	
6. AUTHOR(S) Steve Shikaze, University of Waterloo				
7. PERFORMING ORGANIZATION NAME(S) AND ADDRESS(ES) Applied Research Associates, Inc. 4300 San Mateo Blvd., NE, Suite A220 Albuquerque, NM 87110			8. PERFORMING ORGANIZATION REPORT NUMBER	
9. SPONSORING/MONITORING AGENCY NAME(S) AND ADDRESSES(ES) Armstrong Laboratory Environics Directorate Environmental Risk Management Division 139 Barnes Drive, Suite 2 Tyndall Air Force Base, Florida 32403-5323			10. SPONSORING/MONITORING AGENCY REPORT NUMBER AL/EQ-TR-0020	
11. SUPPLEMENTARY NOTES Contracting Officer's Technical Rep.: Lt Dennis O'Sullivan, (904) 283-6239				
12a. DISTRIBUTION/AVAILABILITY STATEMENT Approved for public release. Distribution unlimited.			12b. DISTRIBUTION CODE	
13. ABSTRACT (Maximum 200 words) The funnel-and-gate system is an in-situ technique for the restoration of contaminated aquifers. It consists of low to impermeable barriers used to divert the groundwater flow through a controlled area. In order to gain insight to the flow field dynamics of such systems, a series of three dimensional calculations was performed. In the calculations the width of the gate and the depth of the barriers were varied. The individual calculations were designed using the Plackett-Burman statistical experimental design method. The results of the calculations were used to develop a statistical model of the funnel-and-gate system (reported separately). The computations show little effect from varying the angle of the walls to the flow field in capturing the flow. The capture zone is also unaffected by increasing the hydraulic head. The higher the conductivity at the gate, the greater the flow and also the capture zone.				
14. SUBJECT TERMS Funnel-and-Gage, Impermeable Barriers, Groundwater Flow,			15. NUMBER OF PAGES 59	
			16. PRICE CODE	
17. SECURITY CLASSIFICATION OF REPORT UNCLASSIFIED	18. SECURITY CLASSIFICATION OF THIS PAGE UNCLASSIFIED	19. SECURITY CLASSIFICATION OF ABSTRACT UNCLASSIFIED	20. LIMITATION OF ABSTRACT UNLIMITED	

PREFACE

The work described in this report covers the contract period of July 1995 through April 1996. This work was performed by Waterloo Centre for Groundwater Research, University of Waterloo, Waterloo, Ontario N2L 3G1 Canada under subcontract to Applied Research Associates (ARA), Inc., Contract F08635-93-C-0020, Subtask 8.03, U.S. Air Force AL/EWQ, Barnes Drive, Suite 2, Tyndall Air Force Base, Florida. During the course of this study, there were two project officers, Major Mark H. Smith and Captain Jeff Stinson, BSC. This work was performed under the technical guidance of Mr. Robert E. Walker, ARA. This report was written by Steve Shikaze of the University of Waterloo and edited by Mr. Walker.

DTIC QUALITY INSPECTED 3

EXECUTIVE SUMMARY

The funnel-and-gate system is an in situ technique for the restoration of contaminated aquifers. It consists of low to impermeable barriers used to divert the groundwater flow through a controlled area. To gain insight to the flow field dynamics of such systems, a series of three-dimensional calculations was performed. In the calculations the width of the gate and the depth of the barriers were varied. The individual calculations were designed using the Plackett-Burman statistical experimental design method. The results of the calculations were used to develop a statistical model of the funnel-and-gate system (reported separately). The computations show little effect from varying the angle of the walls to the flow field in capturing the flow. The capture zone is also unaffected by increasing the hydraulic head. The higher the conductivity at the gate, the greater the flow and also the capture zone.

TABLE OF CONTENTS

Section	Title	Page
I	INTRODUCTION.....	1
	OBJECTIVE.....	1
	BACKGROUND.....	1
	SCOPE.....	2
II	THEORETICAL BACKGROUND.....	3
	NUMERICAL MODEL.....	3
	Governing Equations.....	3
	Incorporation of Impermeable Cutoff Walls.....	4
III	THREE COMPARISON SIMULATIONS.....	5
	CASE 1: FULLY SATURATED FLOW; CUTOFF WALLS PERPENDICULAR TO FLOW.....	5
	CASE 2: PARTIALLY SATURATED FLOW; CUTOFF WALLS PERPENDICULAR TO FLOW.....	6
	CASE 3: FULLY SATURATED FLOW; CUTOFF WALLS 45 DEGREES TO FLOW.....	7
IV	SIMULATIONS FOR RUN MATRIX.....	9
	COMPUTATIONAL DOMAIN AND BOUNDARY CONDITIONS.....	9
	DIMENSIONLESS PARAMETERS.....	9
	RESULTS FROM RUN MATRIX.....	10
V	DISCUSSION.....	12
	REFERENCES.....	14
Appendix		
A	SUPPLEMENTARY OUTPUT - CASE 1 (OF COMPARISON CASES).....	40
B	SUPPLEMENTARY OUTPUT - CASE 2 (OF COMPARISON CASES).....	46
C	SUPPLEMENTARY OUTPUT - CASE 3 (OF COMPARISON CASES).....	54

LIST OF FIGURES

Figure	Title	Page
1	Schematic Diagram of a Typical Funnel-and-Gate System	15
2	Perspective View of a Typical Funnel-and-Gate System	16
3	Streamlines in the Vicinity of a Funnel-and-Gate System	17
4	Streamlines and Capture Zone for Case 1 of Comparison Simulations	18
5	Streamlines and Capture Zone for Case 2 of Comparison Simulations	19
6	Funnel-and-Gate Configuration for Case 3: Representation of Angled Cutoff Walls	20
7	Streamlines and Capture Zone for Case 3 of Comparison Simulations	21
8	3D View of the Computational Domain and Boundary Conditions	22
9	Schematic of an Example of the Funnel-and-Gate Parameters	23
10	Streamlines and Capture Zone for Run #1 of Run Matrix	24
11	Streamlines and Capture Zone for Run #2 of Run Matrix	25
12	Streamlines and Capture Zone for Run #3 of Run Matrix	26
13	Streamlines and Capture Zone for Run #4 of Run Matrix	27
14	Streamlines and Capture Zone for Run #5 of Run Matrix	28
15	Streamlines and Capture Zone for Run #6 of Run Matrix	29
16	Streamlines and Capture Zone for Run #7 of Run Matrix	30
17	Streamlines and Capture Zone for Run #8 of Run Matrix	31
18	Streamlines and Capture Zone for Run #9 of Run Matrix	32
19	Streamlines and Capture Zone for Run #10 of Run Matrix	33
20	Streamlines and Capture Zone for Run #11 of Run Matrix	34
21	Streamlines and Capture Zone for Run #12 of Run Matrix	35
22	Streamlines and Capture Zone for Run #13 of Run Matrix	36
23	Streamlines and Capture Zone for Run #14 of Run Matrix	37
24	Streamlines and Capture Zone for Run #15 of Run Matrix	38
25	Streamlines and Capture Zone for Run #16 of Run Matrix	39
A-1	XY Slice of Hydraulic Head and Velocities, Z = 9.5 meters	41
A-2	XY Slice of Hydraulic Head and Velocities, Z = 5.0 meters	42
A-3	YZ Slice of Hydraulic Head and Velocities, X = 50.0 meters	43
A-4	YZ Slice of Hydraulic Head and Velocities, X = 44.0 meters	44
A-5	YZ Slice of Hydraulic Head and Velocities, X = 40.0 meters	45
B-1	YZ Slice of Pressure Head (Water Table), X = 44.0 meters	47
B-2	YZ Slice of Pressure Head (Water Table), X = 50.0 meters	48
B-3	XY Slice of Hydraulic Head and Velocities, Z = 9.5 meters	49
B-4	XY Slice of Hydraulic Head and Velocities, Z = 5.0 meters	50
B-5	YZ Slice of Hydraulic Head and Velocities, X = 50.0 meters	51
B-6	YZ Slice of Hydraulic Head and Velocities, X = 44.0 meters	52
B-7	YZ Slice of Hydraulic Head and Velocities, X = 40.0 meters	53
C-1	XY Slice of Hydraulic Head and Velocities, Z = 9.5 meters	55
C-2	XY Slice of Hydraulic Head and Velocities, Z = 5.0 meters	56

LIST OF FIGURES (Continued)

Figure		Page
C-3	YZ Slice of Hydraulic Head and Velocities, X = 50.0 meters	57
C-4	YZ Slice of Hydraulic Head and Velocities, X = 47.0 meters	58
C-5	YZ Slice of Hydraulic Head and Velocities, X = 44.0 meters	59

LIST OF TABLES

Table	Title	Page
1	CAPTURE ZONE WIDTH AT VARIOUS DEPTHS - CASE 1	6
2	CONSTITUTIVE RELATIONSHIPS FOR UNSATURATED ZONE PARAMETERS.....	7
3	CAPTURE ZONE WIDTH AT VARIOUS DEPTHS - CASE 2	7
4	CAPTURE ZONE WIDTH AT VARIOUS DEPTHS - CASE 3	8
5	SUMMARY OF PARAMETERS USED IN THE RUN MATRIX	10
6	RESULTS FROM THE RUN MATRIX	11

SECTION I

INTRODUCTION

OBJECTIVE

The purpose of this work was to examine, in 3D, groundwater flow in the vicinity of a partially penetrating funnel-and-gate system.

BACKGROUND

The funnel-and-gate system is an in situ technique for the restoration of contaminated aquifers. It consists of low-permeability barriers or cutoff walls (funnels) which divert the flow of groundwater towards and through the gate. The gate consists of one or a sequence of reactive materials which can either degrade or retard the groundwater contaminants. A funnel-and-gate system can be either fully penetrating or partially penetrating. A fully penetrating funnel-and-gate system implies that it is installed from the ground surface and anchored at some depth below ground surface into a low permeability material (e.g., clay layer). A partially penetrating system is one that is not anchored into a low permeability material, and thus groundwater can flow freely under the system. Figure 1 shows schematic diagrams of a partially penetrating funnel-and-gate system in plan view (Figure 1a) and cross section (Figure 1b).

To gain insight into the effectiveness of funnel-and-gate systems, a numerical modelling study is required. Preliminary work on modelling funnel-and-gate systems includes that by Starr and Cherry (1994) who performed a detailed sensitivity analysis in 2D plan view, and Shikaze et al. (1995) who presented results in 3D. Both of these studies simulated steady-state groundwater flow in the vicinity of a funnel-and-gate system. Christenson and Hatfield (1994) developed an analytical model to examine funnel-and-gate systems. They used Dupuit-Forcheimer assumptions and developed plots showing the relationships between various geometrical parameters of a funnel-and-gate system in 2D areal view. It is worth noting here that all previous 3D work assumes that the funnel-and-gate system is fully penetrating. The key difference for the 2D simulations is that flow under the cutoff walls can be accounted for. In the previously mentioned 2D studies, partially penetrating conditions cannot be considered. Shikaze et al.

funnel-and-gate systems in 3D. However, they only performed a limited number of simulations and only examined one funnel-and-gate geometry.

Figure 2a shows a perspective view of a typical 3D domain. In this case, the funnel-and-gate system is partially penetrating and the dots represent the beginning of a particle trace in a steady-state groundwater flow field. Figure 2b shows the particles again, as well as streamlines based on the flow field. Here, a portion of the original particles eventually passes through the gate. The zone of particles upgradient that ends up passing through the gate is referred to in this work as the capture zone, and is shown in Figure 2b as a black, hatched zone. In this report, capture zones will be shown in a manner similar to that shown in Figure 3. This view is looking towards the funnel-and-gate system in the direction of groundwater flow. From this viewpoint, the capture zone can easily be drawn and measured.

SCOPE

A number of simulations which involved varying one or more of the dimensionless parameters that are used to define the geometry of a funnel-and-gate system were performed. The simulation results presented here have been chosen by Applied Research Associates, Inc. (ARA), and are in the form of a "run-matrix" of 16 simulations. In addition, three simulations have been performed to be used by ARA to compare with another computer program. These three simulations are described in detail in Section III.

Section II describes the numerical model that was used for this work, including a discussion of the governing equations and the incorporation of impermeable cutoff walls. Section III presents the simulations that are to be used by ARA for comparison to another model, and Section IV contains the results from the simulations for the run-matrix, as well as a definition of boundary conditions, and dimensionless parameters.

SECTION II

THEORETICAL BACKGROUND

The model that was used for this project, FRAC3DVS, is described in detail by Therrien (1992) and Therrien and Sudicky (1995). It is a three-dimensional numerical model which can be used to simulate saturated or partially saturated groundwater flow and solute transport in porous or fractured, porous geologic media. For the purposes of this work, we used the model to simulate fully fractured, steady-state groundwater flow in a homogeneous nonfractured aquifer (except for Case 2 in Section III, where steady-state, partially saturated conditions were simulated).

NUMERICAL MODEL

Governing Equations

The partial differential equation that governs fully saturated, steady-state groundwater flow is:

$$K_x \frac{\partial^2 h}{\partial x^2} + K_y \frac{\partial^2 h}{\partial y^2} + K_z \frac{\partial^2 h}{\partial z^2} = 0 \quad (1)$$

where K_x , K_y , K_z are the hydraulic conductivities in the x , y , and z directions, respectively, h is the hydraulic head, and x , y , and z are the spatial coordinates.

The specific discharge is calculated by Darcy's equation:

$$q = -Ki \quad (2)$$

where i is the hydraulic gradient, and q is the specific discharge.

One simulation in Section III involves partially saturated groundwater flow. For partially saturated, steady-state groundwater flow, a modified form of Richards' equation is used to describe groundwater flow (Therrien, 1992):

$$\frac{\partial}{\partial x_i} \left(K_{ij} k_{rw} \frac{\partial (\psi + z)}{\partial x_j} \right) \pm Q = 0 \quad i, j = x, y, z \quad (3)$$

where K_{ij} is the saturated hydraulic conductivity tensor, $k_{rw} = k_{rw}(S_w)$ is the relative permeability of the medium as a function of water saturation, S_w , $\psi = \psi(x_i, t)$ is the pressure head, and z is the elevation head. The saturation of water is related to water content, θ , by:

$$S_w = \frac{\theta - \theta_r}{\theta_s - \theta_r} \quad (4)$$

where θ_r is the residual water content, and θ_s is the porosity. For the partially saturated example in Section III, we use tabular data as input for the $S_w(\psi)$ and $k_{rw}(S_w)$ relationships.

Incorporation of Impermeable Cutoff Walls

Within the 3D computational domain, impermeable cutoff walls are implemented as 2D planes. This is done by adding "false nodes" wherever impermeable nodes are desired. As a consequence, wherever an impermeable wall exists, there are two nodes existing at the same spatial location, one of which is connected to an element on one side of the wall, while the other is connected to the element on the opposite side of the wall. The result is to essentially break the connection between two adjacent elements thereby mimicking an impermeable wall by emplacing a 2D impermeable plane within the 3D domain. The 3D block elements remain unchanged, the only difference being new elemental incidences for elements that are associated with cutoff walls.

SECTION III

THREE COMPARISON SIMULATIONS

The purpose of these three simulations using FRAC3DVS is to present contrasting cases that can be compared, by ARA, to results from another program. All three of these simulations represent partially penetrating systems. These cases are (1) fully saturated, steady-state groundwater flow with cutoff walls perpendicular to the direction of ambient groundwater flow, (2) identical to case (1) except partially saturated flow conditions, and (3) identical to case (1) except that cutoff walls are aligned 45 degrees to the direction of ambient groundwater flow such that the two cutoff walls of the funnel-and-gate system form a "V" shape. The computational domain is essentially identical to that used in the simulations from the Run Matrix, with the only difference being the thickness (i.e., in the z-direction) of the domain. The three simulations are described in further detail below.

CASE 1: FULLY SATURATED FLOW; CUTOFF WALLS PERPENDICULAR TO FLOW

For this simulation, the parameters and boundary conditions are listed below:

- Domain: 100 x 50 x 10 meters (in x, y, z)
- Funnel-and-gate depth = 5 meters
- Gate width = 2 meters
- Cutoff walls: 2- x 10-meter walls (partially penetrating)
 - (1) XY plane at $y = 20$ meters, from $x = 39$ to 49 meters, $z = 5$ to 10 meters
 - (2) XZ plane at $y = 20$ meters, from $x = 51$ to 61 meters, $z = 5$ to 10 meters
- Hydraulic gradient = 0.005 m/m (flow is parallel to y-axis)
- $K_{aquifer} = 10^{-4}$ m/s; porosity = 0.33
- $K_{gate} = K_{aquifer}$
- Boundary conditions:
 - hydraulic head (h_1) = 10.25 meters on XZ plane at $y = 50$ meters, from $x = 0$ to 100 meters, $z = 0$ to 10 meters
 - hydraulic head (h_2) = 10.00 meters on XZ plane at $y = 0$ meters, from $x = 0$ to 100 meters, $z = 0$ to 10 meters

- all other domain boundaries are impermeable
- number of nodes is approximately 180,000

For Case 1, the flow rate through the gate was determined to be approximately 0.86 m³/day (NOTE: these flow calculations were determined by summing the specific discharge, q , of all 3D block elements at the front face of the gate, and multiplying this by the total flow-through area of the gate, A).

The resulting capture zone for Case 1 is shown in Figure 4 and is parabolic in shape, with decreasing width as depth increases. The parabolic shape is a result of the fact that the funnel-and-gate system is a hanging system and groundwater flow is permitted to pass under the funnel-and-gate. Table 1 lists the width of the capture zone at various depths below the top of the computational domain.

TABLE 1. CAPTURE ZONE WIDTH AT VARIOUS DEPTHS - CASE 1.

Depth (m)	Capture zone width (m)
0.0	11.5
1.0	9.5
2.0	7.3
3.0	5.1
4.0	2.6

Other results from Case 1 are presented in Appendix A, including 2D slices of velocity vectors and hydraulic head contours.

CASE 2: PARTIALLY SATURATED FLOW; CUTOFF WALLS PERPENDICULAR TO FLOW

For Case 2, the funnel-and-gate geometry has been set up to be identical to that in Case 1 as described in the previous section (i.e., partially penetrating funnel-and-gate, walls perpendicular to flow). However, Case 2 involves partially saturated groundwater flow, and as a result the boundary conditions are defined differently, as presented below:

- Boundary conditions
 - $h_1 = 8.25$ meters
 - $h_2 = 8.0$ meters
 - top boundary has recharge of 0.00055 m/day

Because this is a partially saturated simulation, we must define the relationship between pressure head and saturation, and relative permeability and saturation. These relationships are tabulated in Table 2.

TABLE 2. CONSTITUTIVE RELATIONSHIPS FOR UNSATURATED ZONE PARAMETERS.

Pressure head (m)	Saturation	Relative k	Saturation
-10.0	0.12	0.0001	0.20
-3.0	0.20	0.01	0.40
-1.0	0.35	0.1	0.63
0.0	1.0	1.0	1.0

For Case 2, the flow rate through the gate is approximately 0.78 m³/day. Figure 5 shows the capture zone for this case at various depths, and these capture zone results are listed in Table 3.

TABLE 3. CAPTURE ZONE WIDTH AT VARIOUS DEPTHS - CASE 2.

Depth (m)	Capture zone width (m)
0.0	8.0
1.0	7.8
2.0	7.0
3.0	5.5
4.0	2.6

Appendix B shows other figures from Case 2 (2D plots of hydraulic head contours and velocity vectors).

CASE 3: FULLY SATURATED FLOW; CUTOFF WALLS 45 DEGREES TO FLOW

Case 3 has been set up with identical boundary conditions to Case 2 with fully saturated groundwater flow. However, in this case, the two cutoff walls are oriented 45 degrees to the direction of groundwater flow. This was done by "stepping" in 0.5-meter increments using orthogonal cutoff walls (see Figure 6). As before, the funnel-and-gate system penetrates to a depth of 5 meters.

Figure 7 shows the resulting capture zone, and capture zone widths are listed in Table 4 for various depths below surface.

TABLE 4. CAPTURE ZONE WIDTH AT VARIOUS DEPTHS - CASE 3.

Depth (m)	Capture zone width (m)
0.0	13.5
1.0	11.1
2.0	7.5
3.0	2.2
4.0	0.0

The flow rate through the gate is approximately $0.75 \text{ m}^3/\text{day}$, and additional results for Case 3 are shown in Appendix C.

SECTION IV

SIMULATIONS FOR RUN MATRIX

COMPUTATIONAL DOMAIN AND BOUNDARY CONDITIONS

The computational domain for simulations for the run matrix has been set up to be 100 by 50 meters in the x and y directions, respectively. In the vertical (z) direction, the domain was varied between 10 and 18 meters to accommodate the desired funnel-and-gate geometry for each specific simulation.

For all simulations, the hydraulic conductivity and porosity of the aquifer were set as 10^{-4} m/s and 0.33, respectively. The hydraulic conductivity of the gate was varied from a low of 10^{-4} m/s to a high of 200^{-4} m/s. The number of nodes for each simulation varied such that an adequate spatial discretization was attained in the vicinity of the funnel-and-gate. In other words, small grid blocks were used near the funnel-and-gate, and larger grid blocks were used further away from the funnel-and-gate. The range in the number of nodes was between about 164,000 and 296,000.

All simulations presented in this section involve steady-state, fully saturated groundwater flow in a 3D flow domain with partially penetrating funnel-and-gate systems. Boundary conditions have been set up such that the ambient flow of groundwater is parallel to the y-axis (see Figure 8). This is done by setting constant head boundary conditions along the end XZ faces (i.e., at $y = 0$ and 50 meters). The values of these specified head faces were varied in order to obtain the desired hydraulic gradient for each simulation. All other boundary faces were assumed to be impermeable boundaries.

DIMENSIONLESS PARAMETERS

To define the geometry of a funnel-and-gate system as well as relevant aquifer parameters, several dimensionless parameters have been defined. The main reason for using dimensionless parameters is to reduce the number of variables in the system. The four dimensionless parameters are as follows: (a) the ratio of the hydraulic conductivity of the gate to

that of the aquifer, $\left(\frac{K_{gate}}{K_{aquifer}}\right)$, (2) the ratio of the width of a single cutoff wall to the depth of the funnel-and-gate, $\left(\frac{w_f}{d_f}\right)$, (3) the ratio of the total cutoff wall width to the gate width, $\left(\frac{2 * w_f}{w_g}\right)$, and (4) the hydraulic gradient, $\left(\frac{\Delta h}{\Delta l}\right)$. Figure 9 shows the definition of these parameters in the context of a typical funnel-and-gate system.

RESULTS FROM RUN MATRIX

Table 5 shows the 16 simulations as shown by ARA. These simulations were chosen on the basis of minimum, maximum, and mean values for each of the four dimensionless parameters, as described above. Also shown in Table 5 are the values of the depth of the funnel and gate (d_f), as well as the width of one cutoff wall (w_f) and the width of the gate (w_g) for each simulation.

TABLE 5. SUMMARY OF PARAMETERS USED IN THE RUN MATRIX.

Run	$\frac{K_{gate}}{K_{aquifer}}$	$\frac{w_f}{d_f}$	$\frac{2 * w_f}{w_g}$	grad h	d_f (m)	w_g (m)	w_f (m)
1	4	2.0	10	0.005	5	2	10
2	1	0.5	5	0.001	7	1.4	3.5
3	1	0.5	20	0.010	14	0.7	7
4	1	4.0	5	0.010	2.5	4	10
5	1	4.0	20	0.001	5	2	20
6	20	0.5	5	0.010	7	1.4	3.5
7	20	0.5	20	0.001	14	0.7	7
8	20	4.0	5	0.001	2.5	4	10
9	20	4.0	20	0.010	5	2	20
10	4	4.0	20	0.005	5	2	20
11	20	4.0	10	0.005	2.5	2	10
12	1	4.0	5	0.001	2.5	4	10
13	4	0.5	10	0.010	10	1	5
14	4	0.5	20	0.001	14	0.7	7
15	20	0.5	10	0.001	10	1	5
16	1	0.5	5	0.010	7	1.4	3.5

Figures 10 to 25 show the capture zones for these 16 simulations, and the relative capture zones are shown in Table 6.

Q_{rel} (or relative flow through the gate is defined as Q_{gate} divided by the total Q through an area equal to the funnel-and-gate area (in the absence of the funnel-and-gate). Relative depth is defined as the depth of measurement of the capture zone width divided by d_f , and the relative capture zone width is defined as the capture zone width (in meters) divided by the total width of the funnel-and-gate system (which is defined as $2 * w_f + w_g$).

The capture zone widths at relative depths of 0.0, 0.2, 0.4, 0.6 and 0.8 are shown on the figures. Because the measurement of the width of a capture zone is approximate, relative capture zone widths are accurate only to within about 0.02.

TABLE 6. RESULTS FROM THE RUN MATRIX.

Run	Q_{gate} ($\frac{m^3}{day}$)	Q_{rel}	Relative capture zone width at relative depth =				
			0.0	0.2	0.4	0.6	0.8
1	1.21	0.255	0.50	0.45	0.37	0.26	0.14
2	0.15	0.295	0.49	0.49	0.48	0.48	0.40
3	3.03	0.170	0.43	0.41	0.41	0.41	0.31
4	1.12	0.216	0.42	0.35	0.30	0.23	0.18
5	0.19	0.105	0.29	0.24	0.18	0.12	0.06
6	2.66	0.524	0.58	0.58	0.58	0.58	0.51
7	0.61	0.343	0.46	0.46	0.46	0.46	0.31
8	0.18	0.347	0.46	0.40	0.34	0.28	0.23
9	3.04	0.168	0.36	0.27	0.20	0.14	0.09
10	1.30	0.144	0.36	0.27	0.20	0.14	0.07
11	0.59	0.249	0.40	0.35	0.29	0.23	0.17
12	0.11	0.217	0.42	0.35	0.30	0.23	0.18
13	3.26	0.343	0.51	0.51	0.51	0.51	0.40
14	0.49	0.275	0.42	0.42	0.42	0.42	0.31
15	0.40	0.418	0.52	0.52	0.52	0.52	0.41
16	1.49	0.298	0.49	0.49	0.49	0.49	0.41

SECTION V

DISCUSSION

The effect of each of the four dimensionless parameters can be examined by comparing several of the above 16 cases. First, Runs 2 and 16 can be compared to examine the effect of hydraulic gradient. All three other dimensionless parameters are constant for simulations 2 and 16. It can be seen that for the case of a higher hydraulic gradient (Run 16), the absolute flow rate through the gate (Q_{gate}) increases. However, the relative flow through the gate, (Q_{rel}), and the relative size of the capture zone remain essentially unaffected by the increase in hydraulic gradient.

To examine the effect of variations in the $\frac{K_{gate}}{K_{aquifer}}$ ratio, several comparisons can be made. Comparison of Runs 6 and 16, 7 and 14, and 8 and 12 are three comparisons where all other dimensionless parameters are constant. All three comparisons show that for higher values of K_{gate} relative to $K_{aquifer}$, both Q_{gate} and Q_{rel} increase as well as the relative size of the capture zone. Higher hydraulic conductivities tend to draw more flow towards the gate, thereby increasing the flow rates through the gate (both absolute and relative). Moreover, the size of the capture zone is increased.

Comparison of Runs 2 and 12 and 4 and 16 allows an examination of the effect of the $\frac{w_f}{d_f}$ ratio (the ratio of the width of a single cutoff wall to the depth of the funnel-and-gate system). Higher values of this ratio result in lower Q_{rel} and Q_{gate} values and smaller relative capture zones. This is because larger values of this ratio result from higher w_f values, and lower d_f values, in which case, each cutoff wall is wider and shallower, thereby increasing the component of flow that is diverted under the cutoff walls rather than through the gate.

Finally, the ratio $\frac{2 * w_f}{w_g}$ (i.e., the ratio of the total cutoff wall width to the width of the gate) can be examined by comparing Runs 5 and 12 and 3 and 16. Higher values of this ratio result in higher Q_{gate} values, but lower Q_{rel} values and smaller relative capture zones. The reason for this is that larger values of this ratio result in more cutoff wall material per unit of gate

opening. This will lead to more flow directed through the gate, but the increase in flow through the gate is not proportional to the increase in cutoff wall material. This results in a lower Q_{rel} value.

REFERENCES

Christensen, B.A. and K. Hatfield, "In Situ Restoration of Contaminated Surficial Aquifers. Part I: The Flow Process," In Future Groundwater Resources at Risk, Proceedings of the Helsinki Conference, IAHS Publication 222, June 1994.

Shikaze, S.G., C.D. Austrins, D.J.A. Smyth, J.A. Cherry, J.F. Barker, and E.A. Sudicky, "The Hydraulics of a Funnel-and-Gate System: A Three-Dimensional Numerical Analysis," Abstract submitted to IAH Congress XXVI: Solutions '95, Edmonton, Alberta, June 1995.

Starr, R.C. and J.A. Cherry, "In Situ Remediation of Contaminated Groundwater: The Funnel-and-Gate System," Ground Water, vol. 32, no. 3, pp. 465-476, 1994.

Therrien, R., "Three-Dimensional Analysis of Variably-Saturated Flow and Solute Transport in Discretely-Fractured Porous Media," PhD Thesis, Department of Earth Science, University of Waterloo, 1992.

Therrien, R. and E.A. Sudicky, "Three-Dimensional Analysis of Variably-Saturated Flow and Solute Transport in Discretely-Fractured Porous Media," Accepted by Journal of Contaminant Hydrology, 1995.

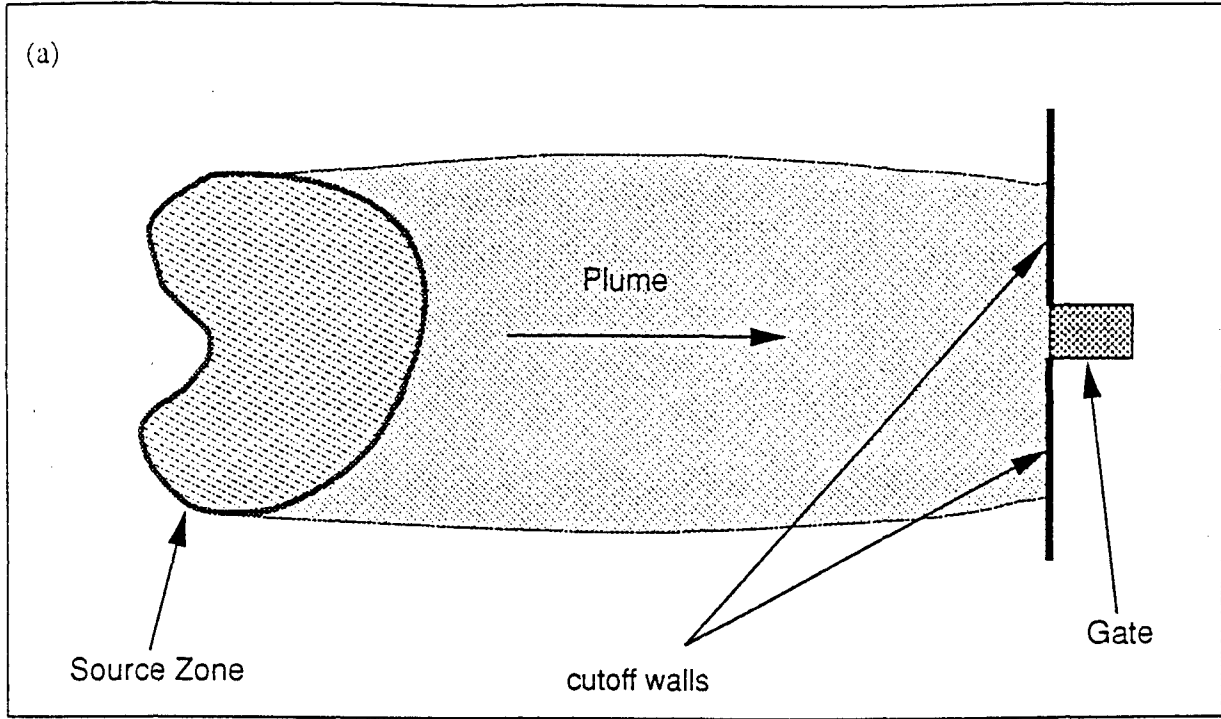

(a) plan view

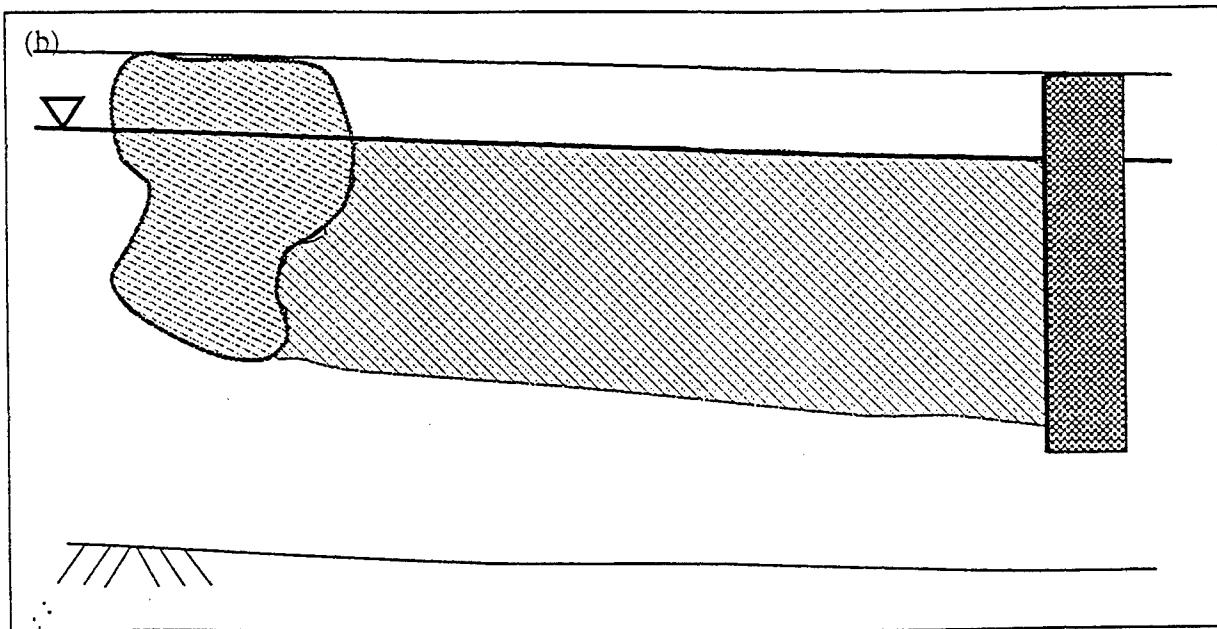

(b) cross section of a partially penetrating system

Figure 1. Schematic Diagram of a Typical Funnel-and-Gate System.

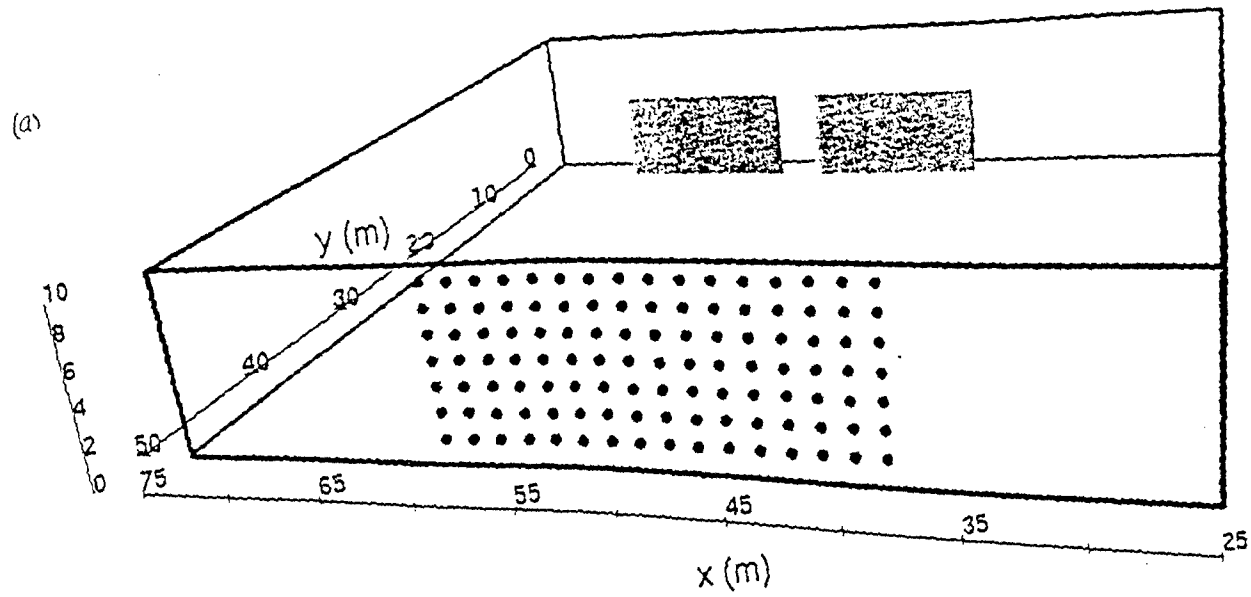

(a) particles at the beginning of particle tracking

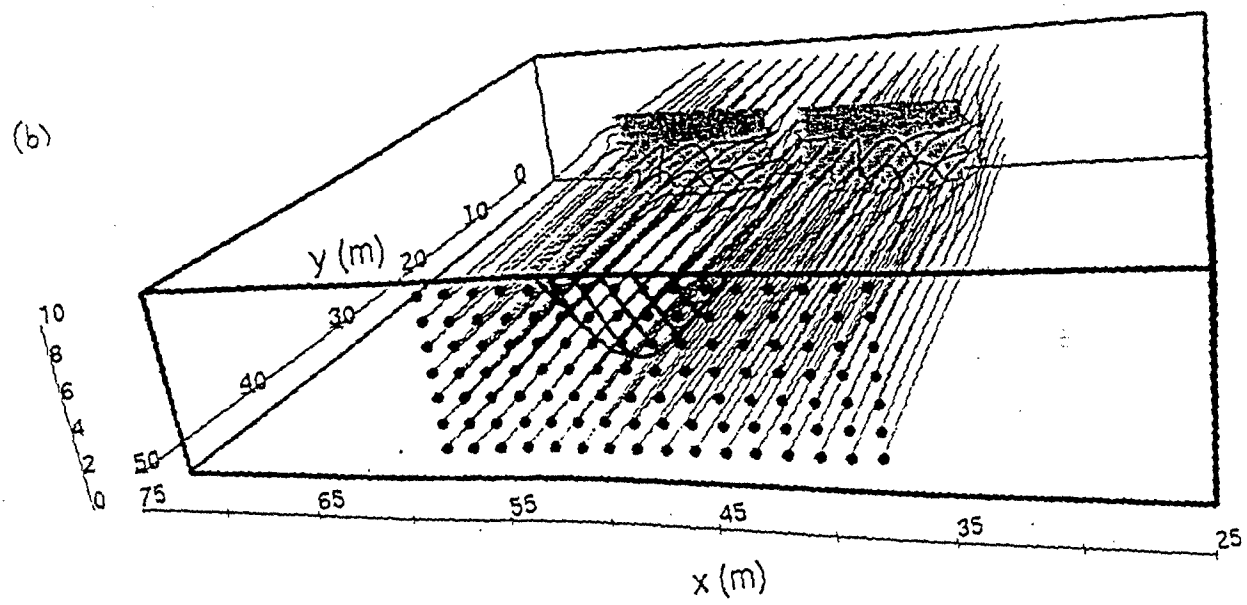

(b) streamlines

Figure 2. Perspective View of a Typical Funnel-and-Gate System.

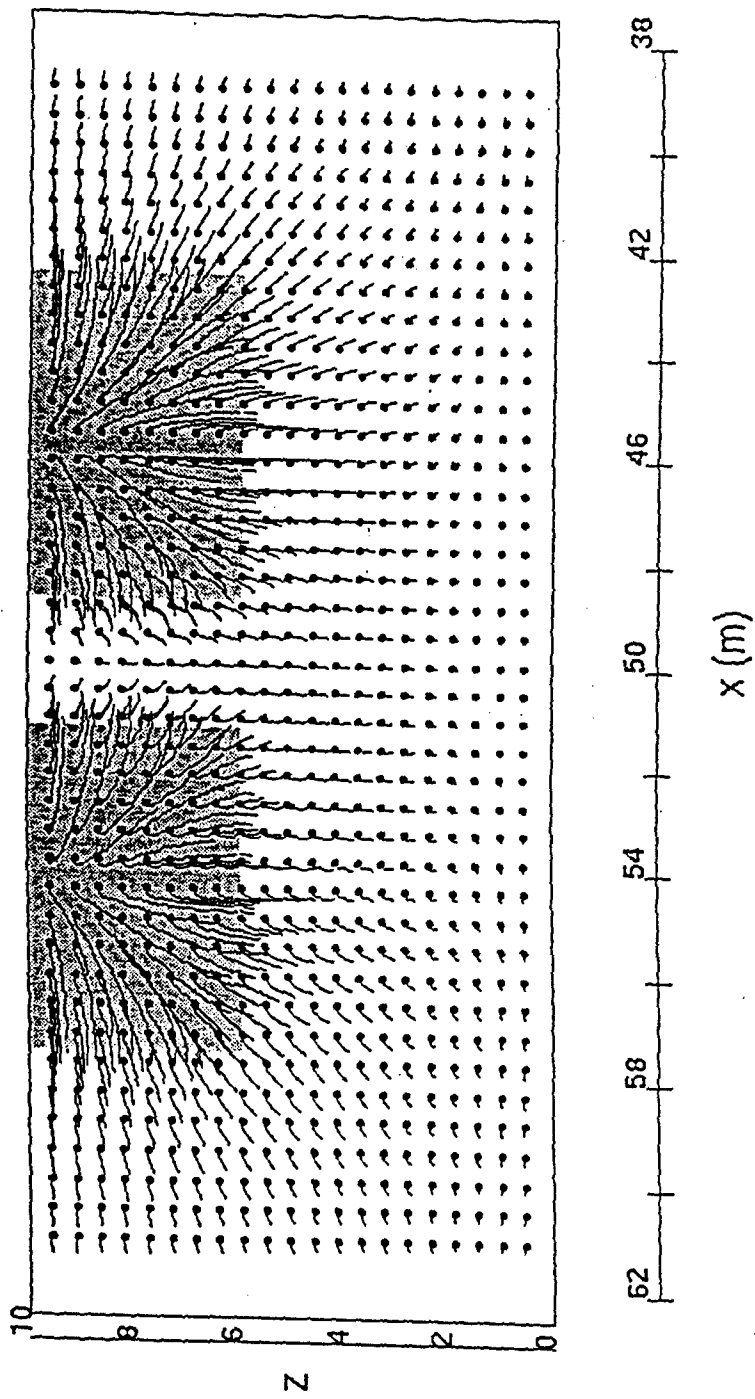

Figure 3. Streamlines in the Vicinity of Funnel-and-Gate System. The View is Looking in the Direction of the Flow, Towards the Funnel-and-Gate. The Dots Represent the Beginning of Each Streamline.

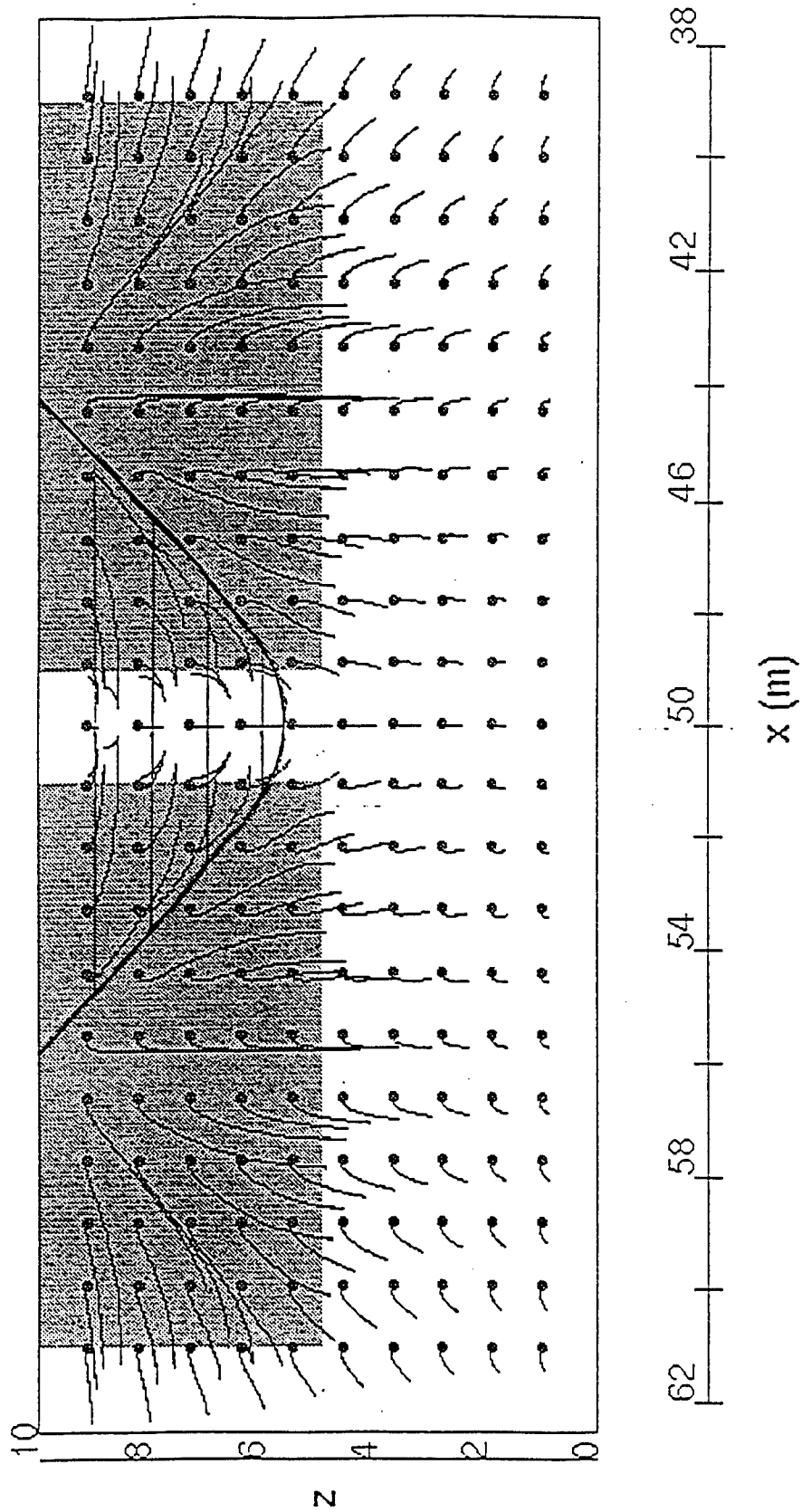

Figure 4. Streamlines and Capture Zone for Case 1 of Comparison Simulations.

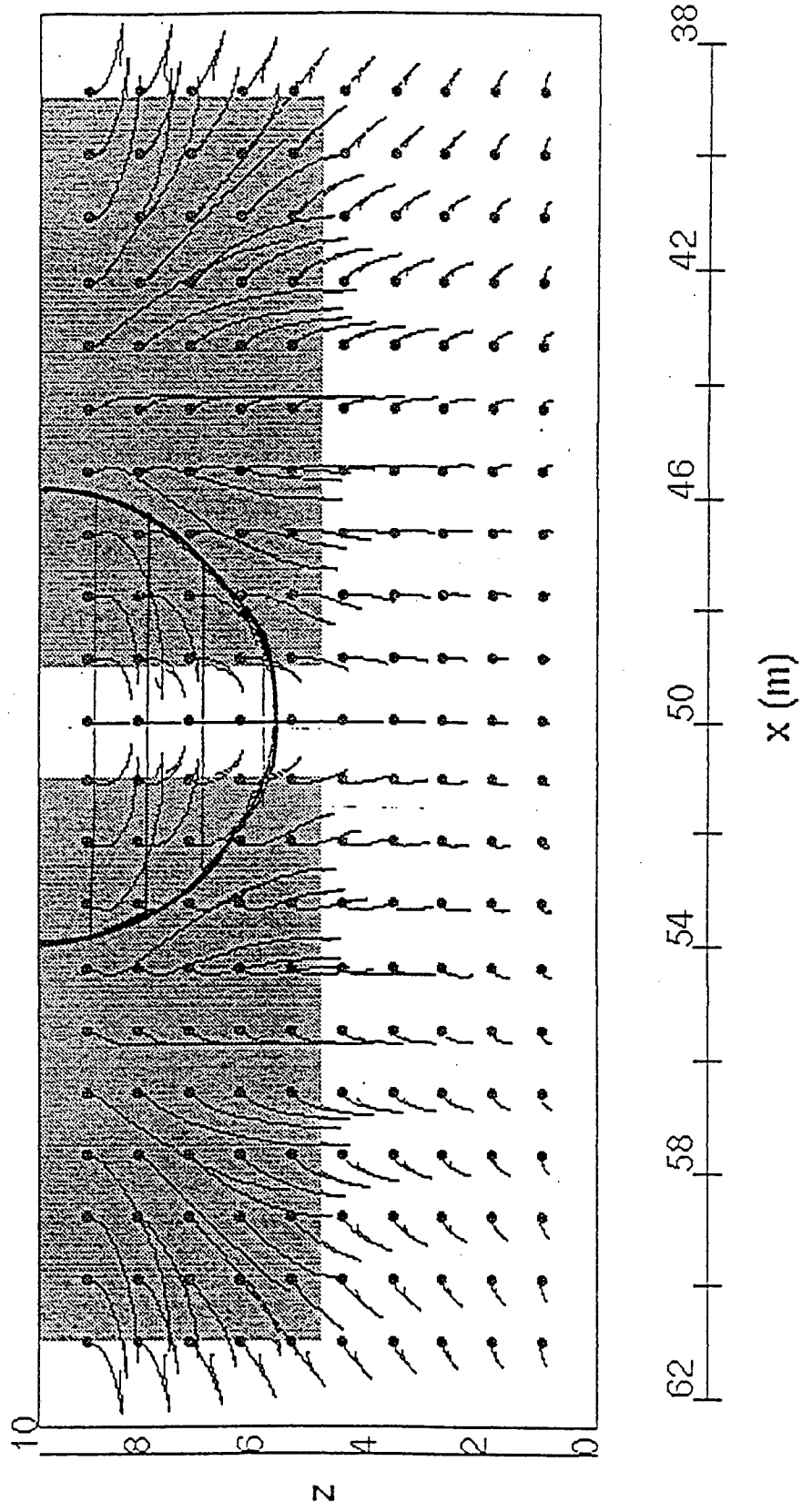
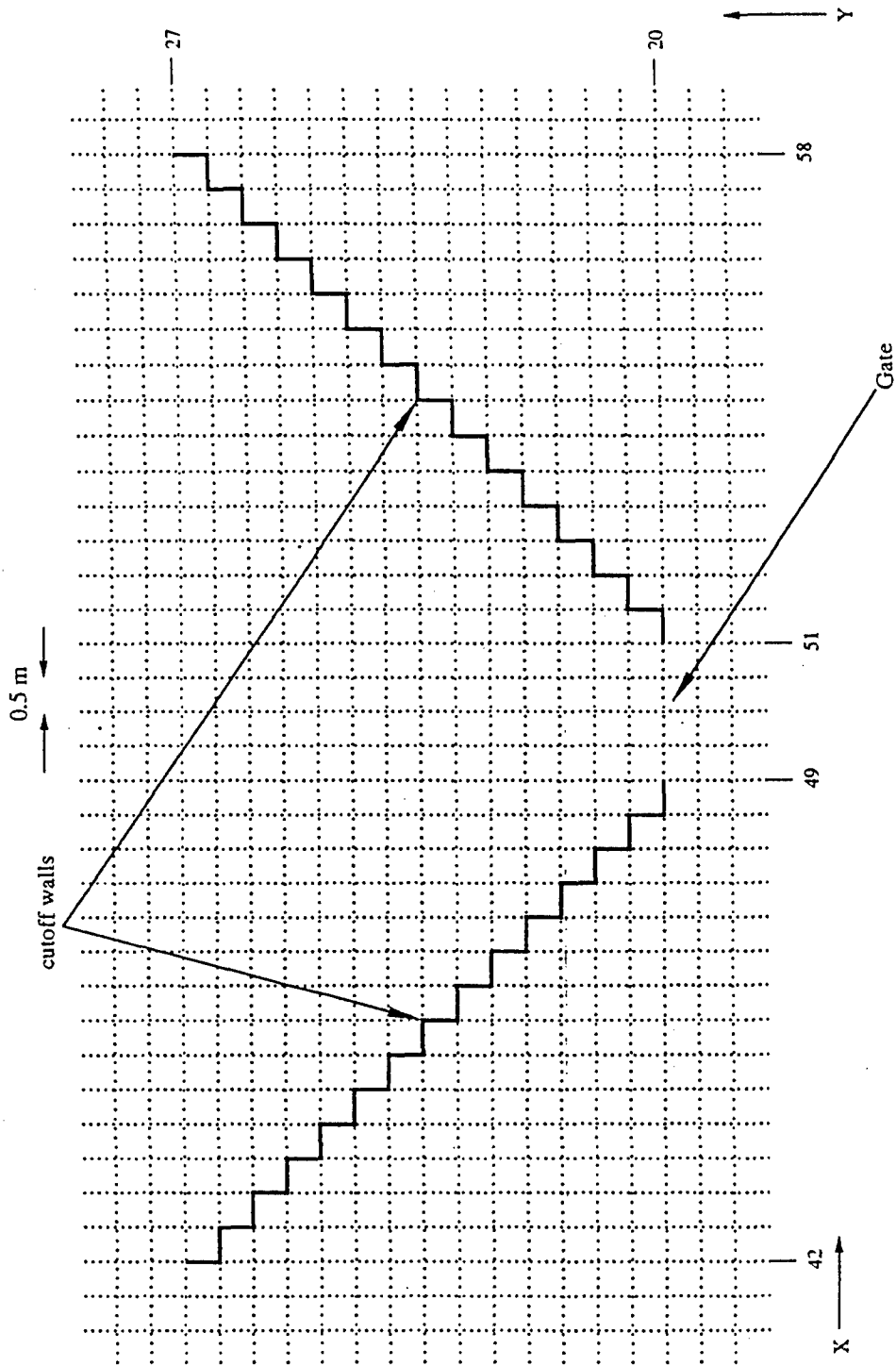

Figure 5. Streamlines and Capture Zone for Case 2 of Comparison Simulations.



Note: Actual grid spacing from $x = 42$ to 58 and $y = 20$ to 27 is 0.25 metres.

Figure 6. Funnel-and-Gate Configuration for Case 3: Representation of Angled Cutoff Walls.

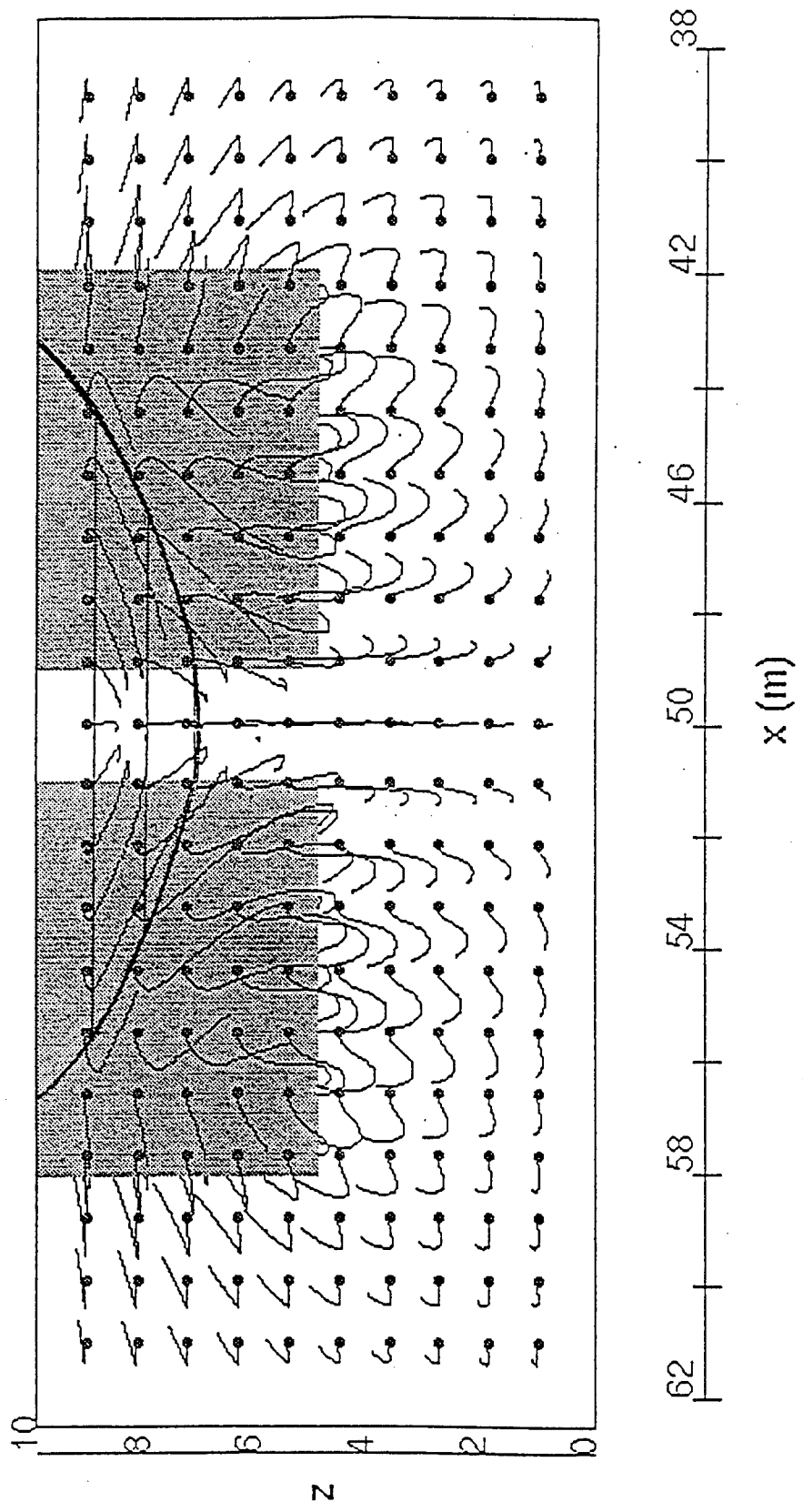

Figure 7. Streamlines and Capture Zone for Case 3 of Comparison Simulations.

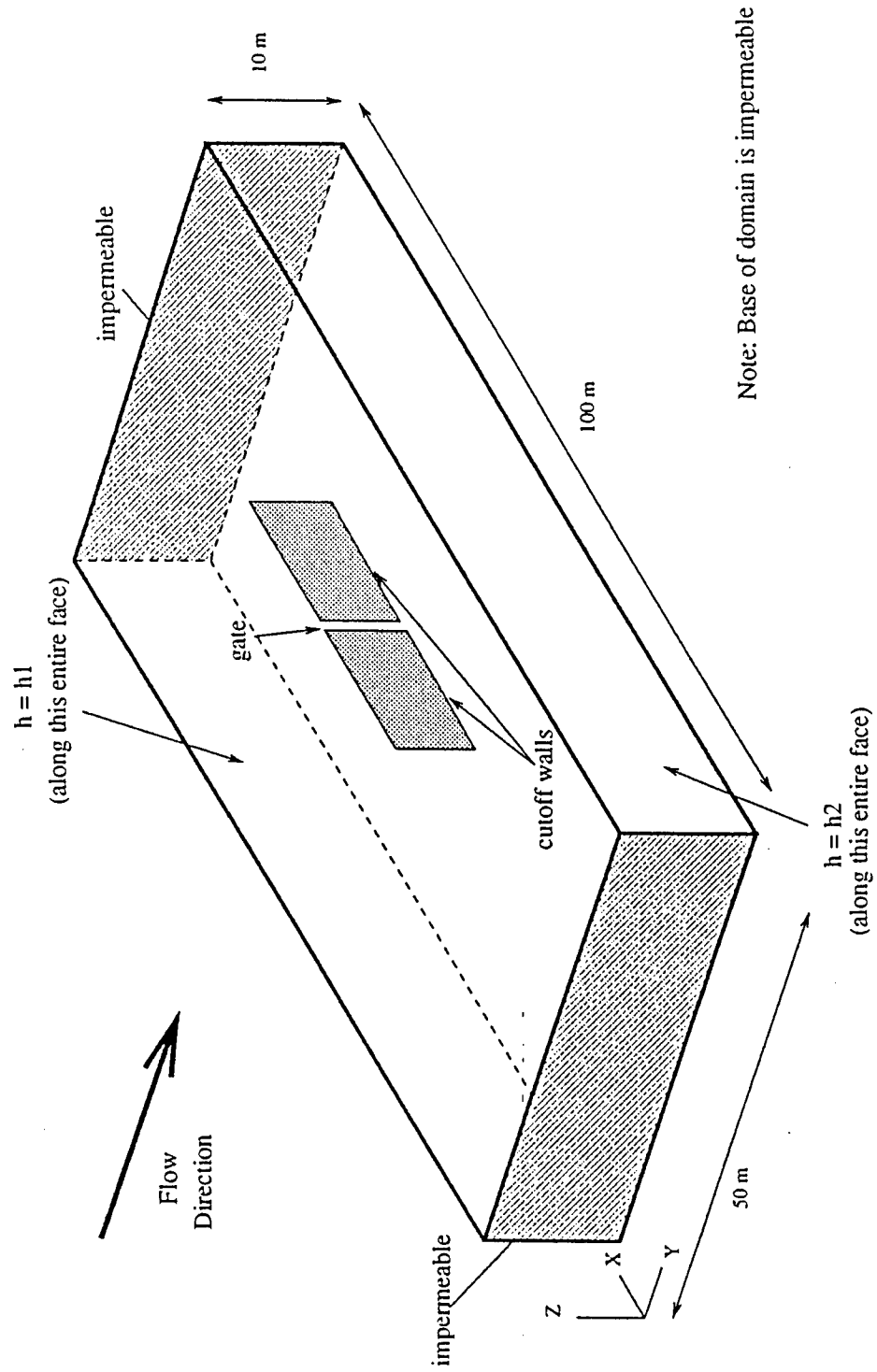
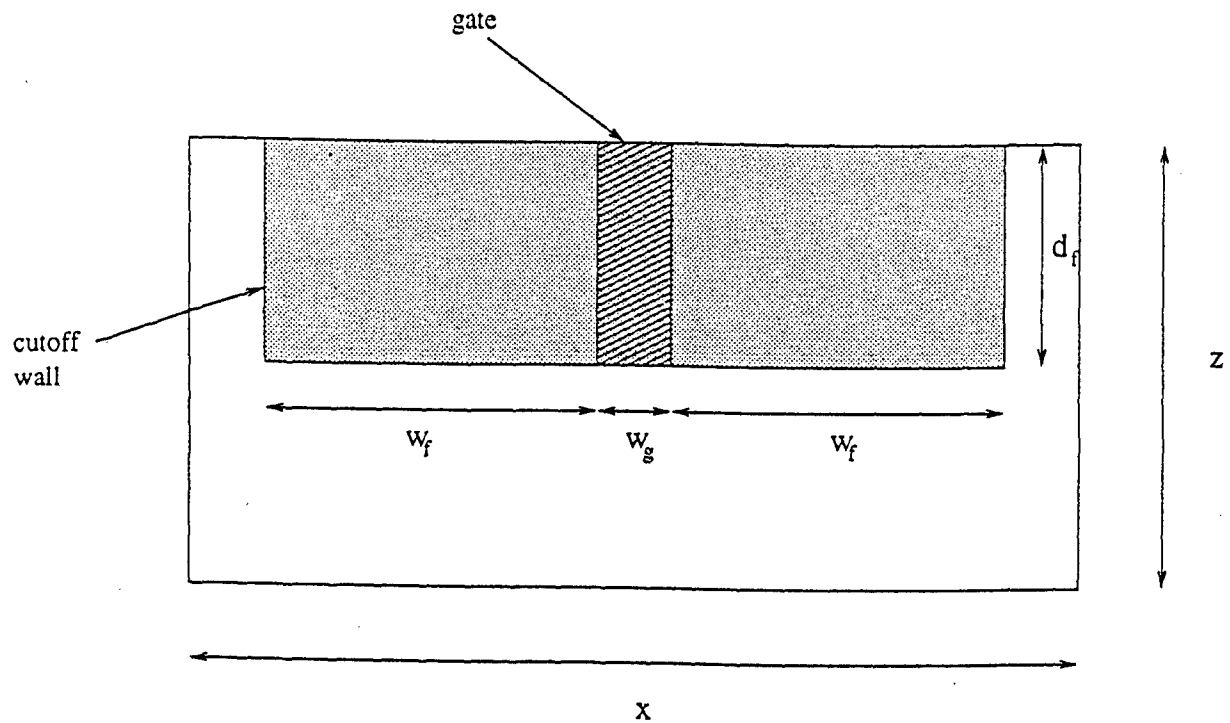

Figure 8. 3D View of the Computational Domain and Boundary Conditions.



w_f = width of one (of two) cutoff walls

w_g = width of the gate

d_f = depth of the funnel-and-gate system

Figure 9. Schematic of an Example of the Funnel-and-Gate Parameters (Looking in the Direction of Flow, Towards the Funnel-and-Gate).

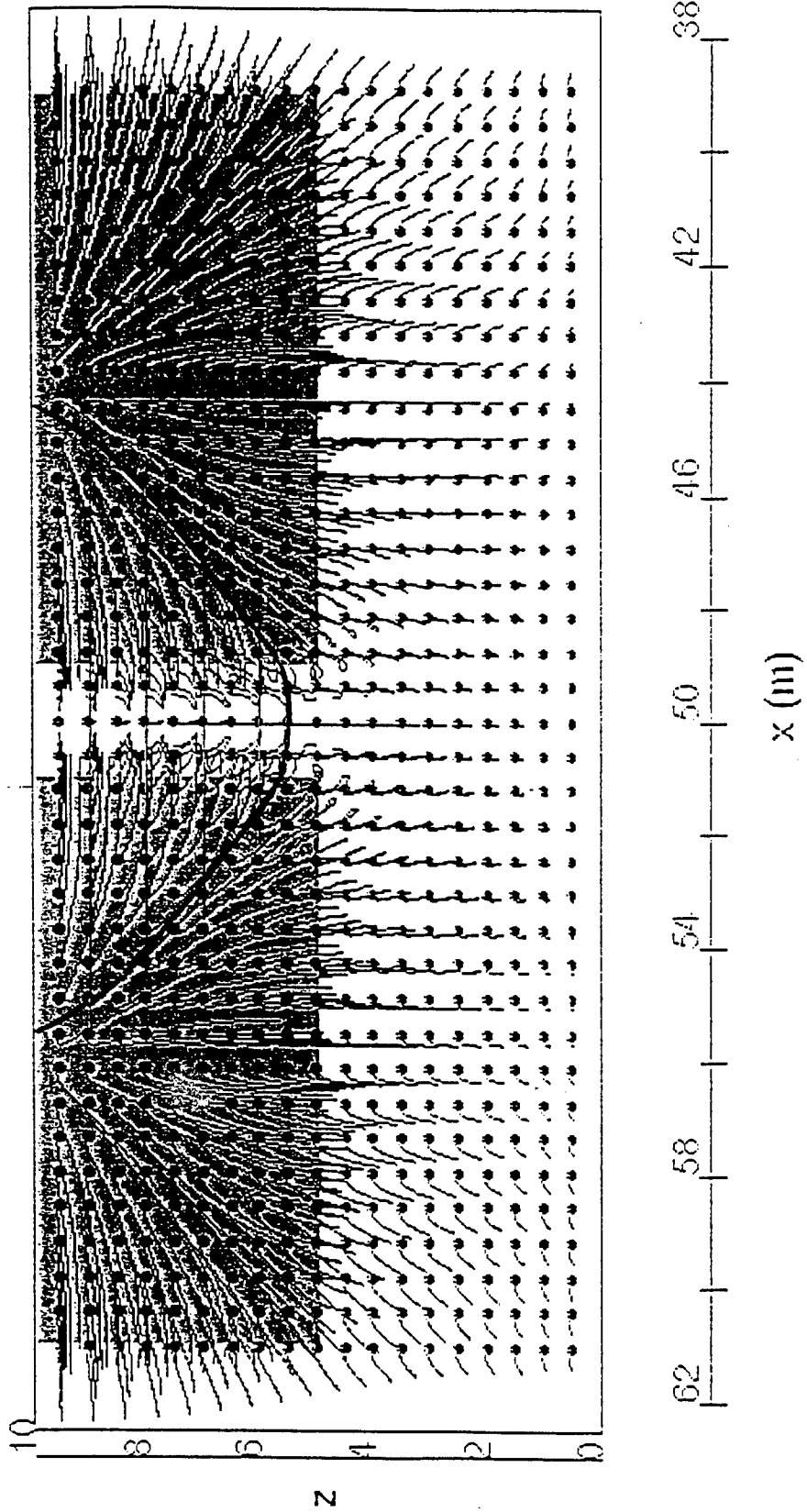

Figure 10. Streamlines and Capture Zone for Run #1 of Run Matrix.

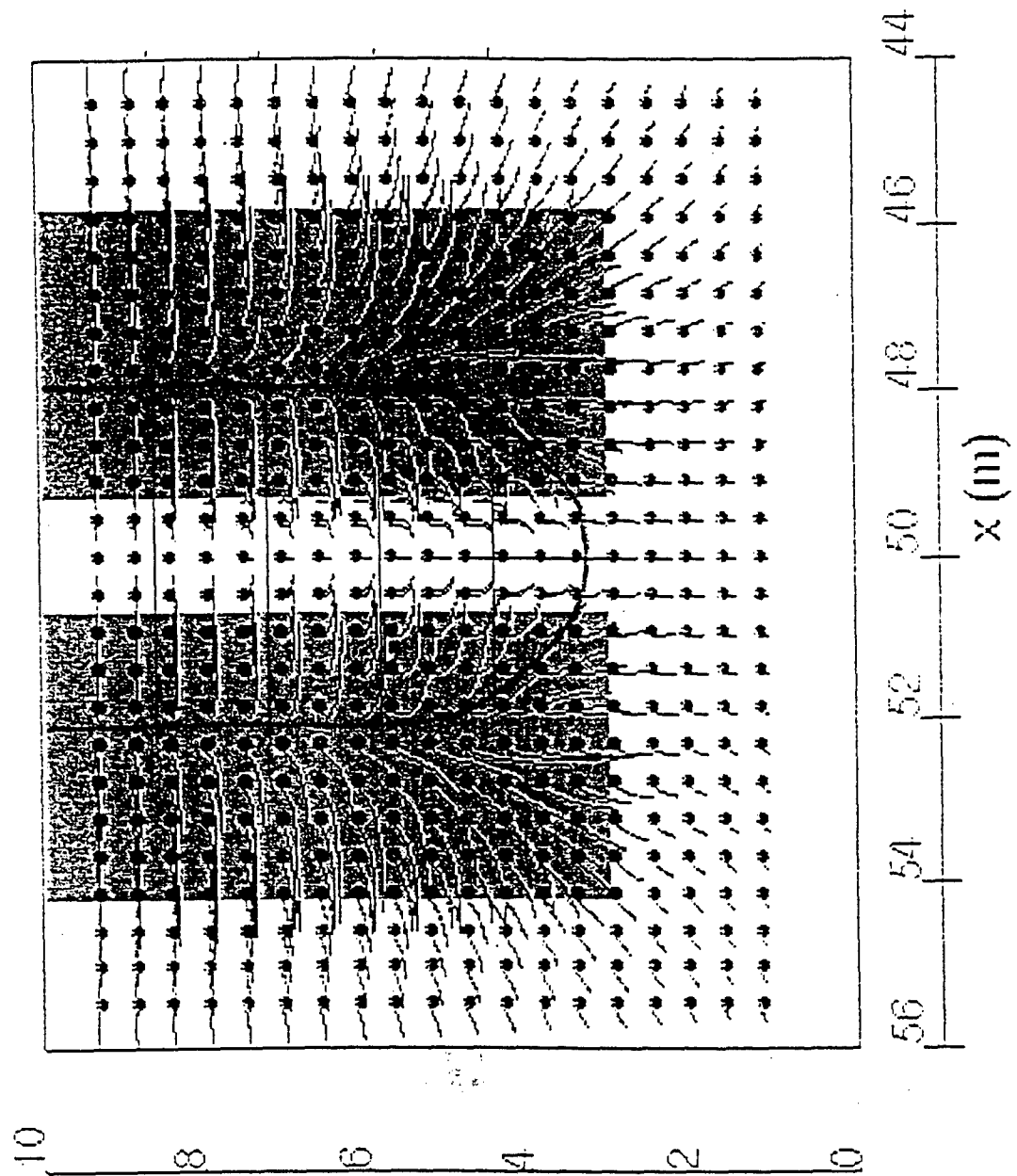

Figure 11. Streamlines and Capture Zone for Run #2 of Run Matrix.

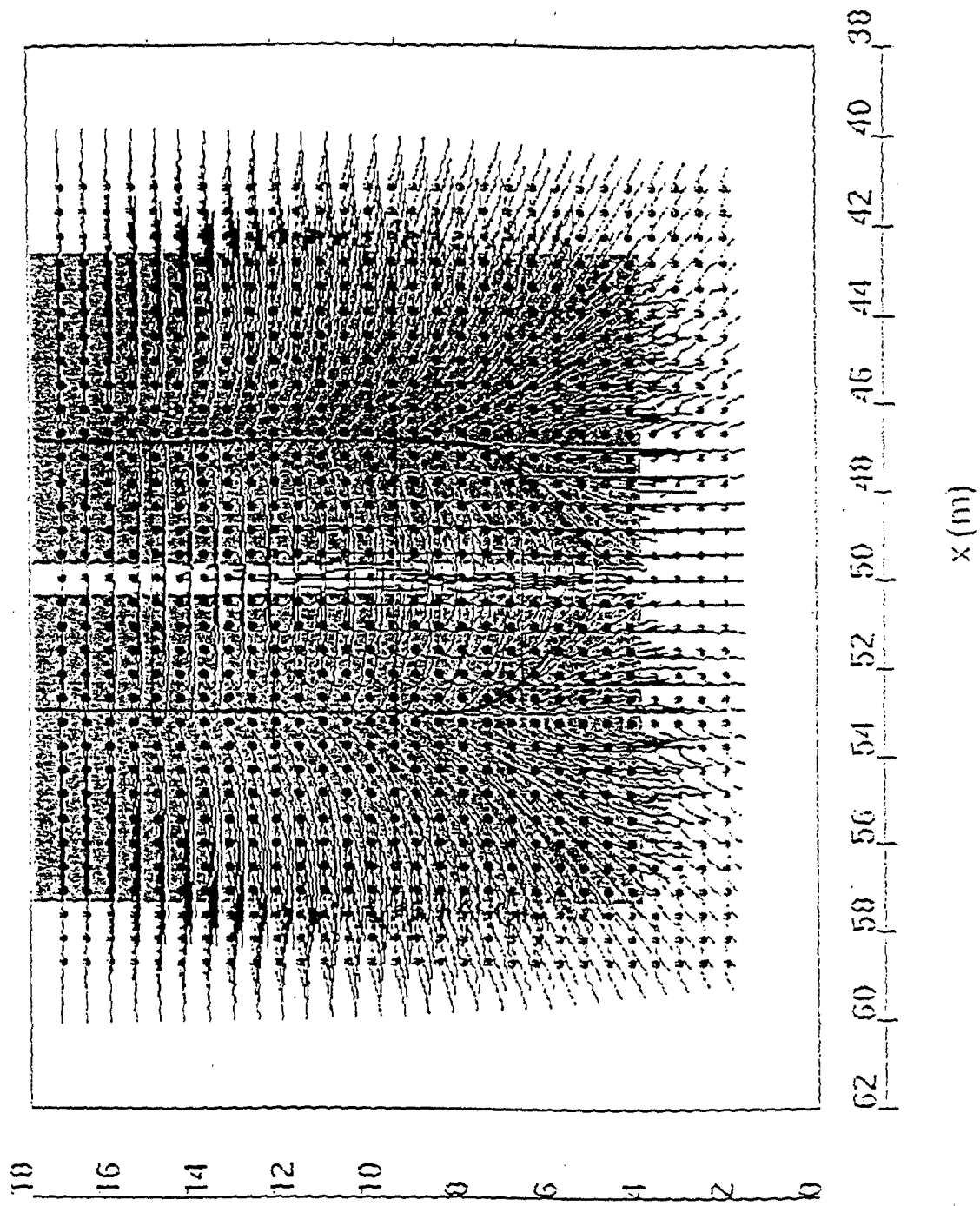

Figure 12. Streamlines and Capture Zone for Run #3 of Run Matrix.

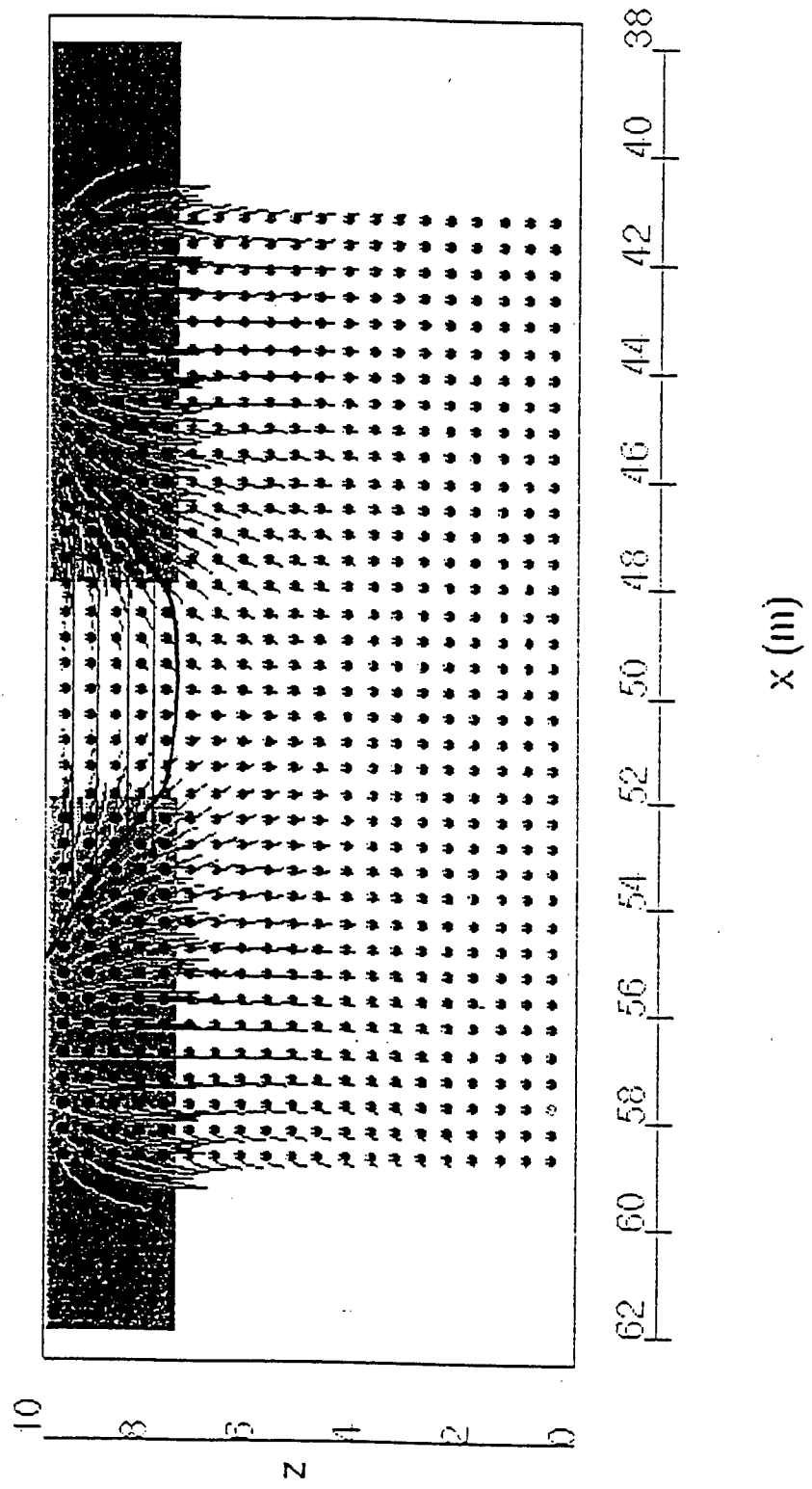
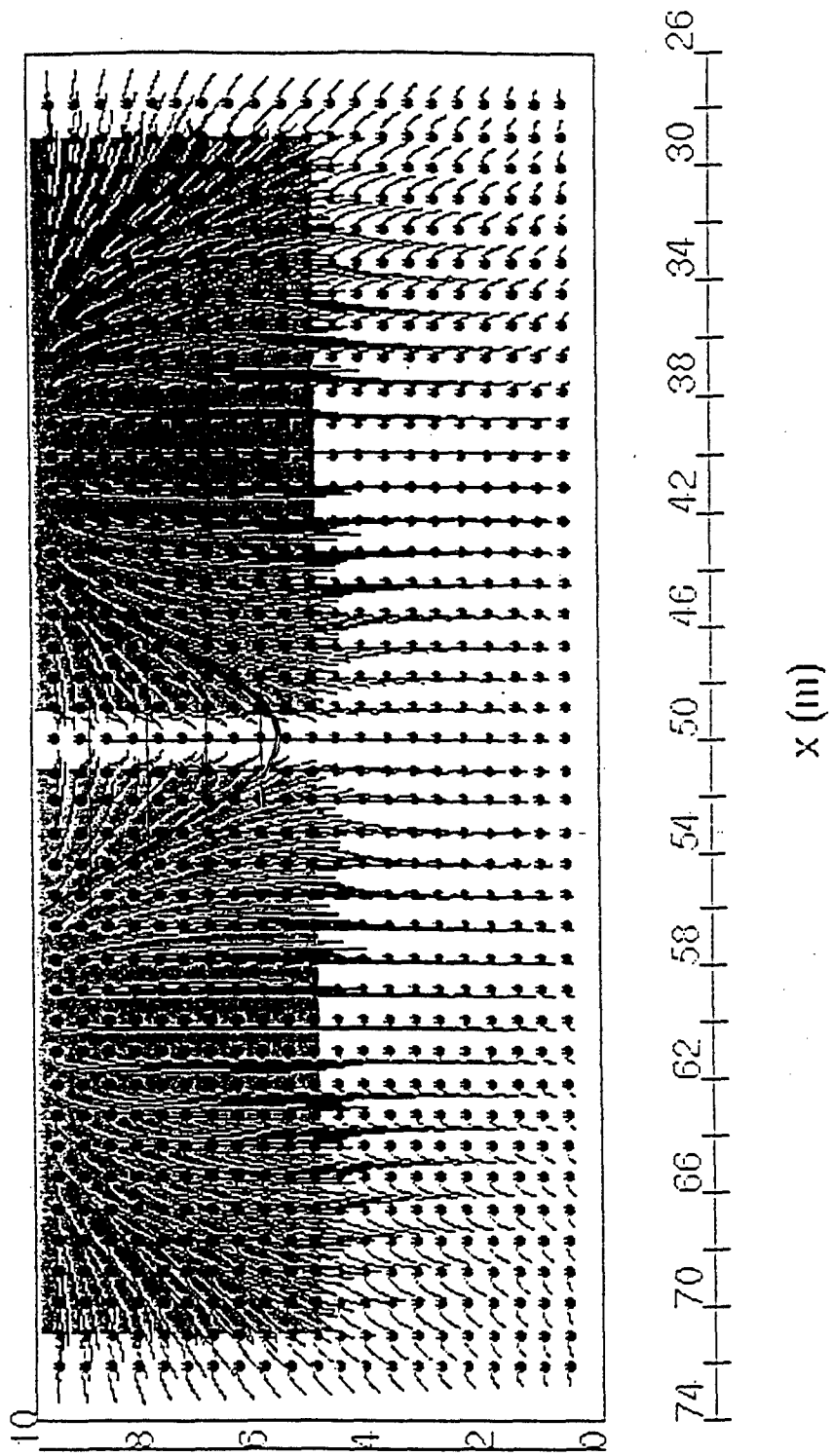

Figure 13. Streamlines and Capture Zone for Run #4 of Run Matrix.



Note: Vertical exaggeration = 2.0

Figure 14. Streamlines and Capture Zone for Run #5 of Run Matrix.

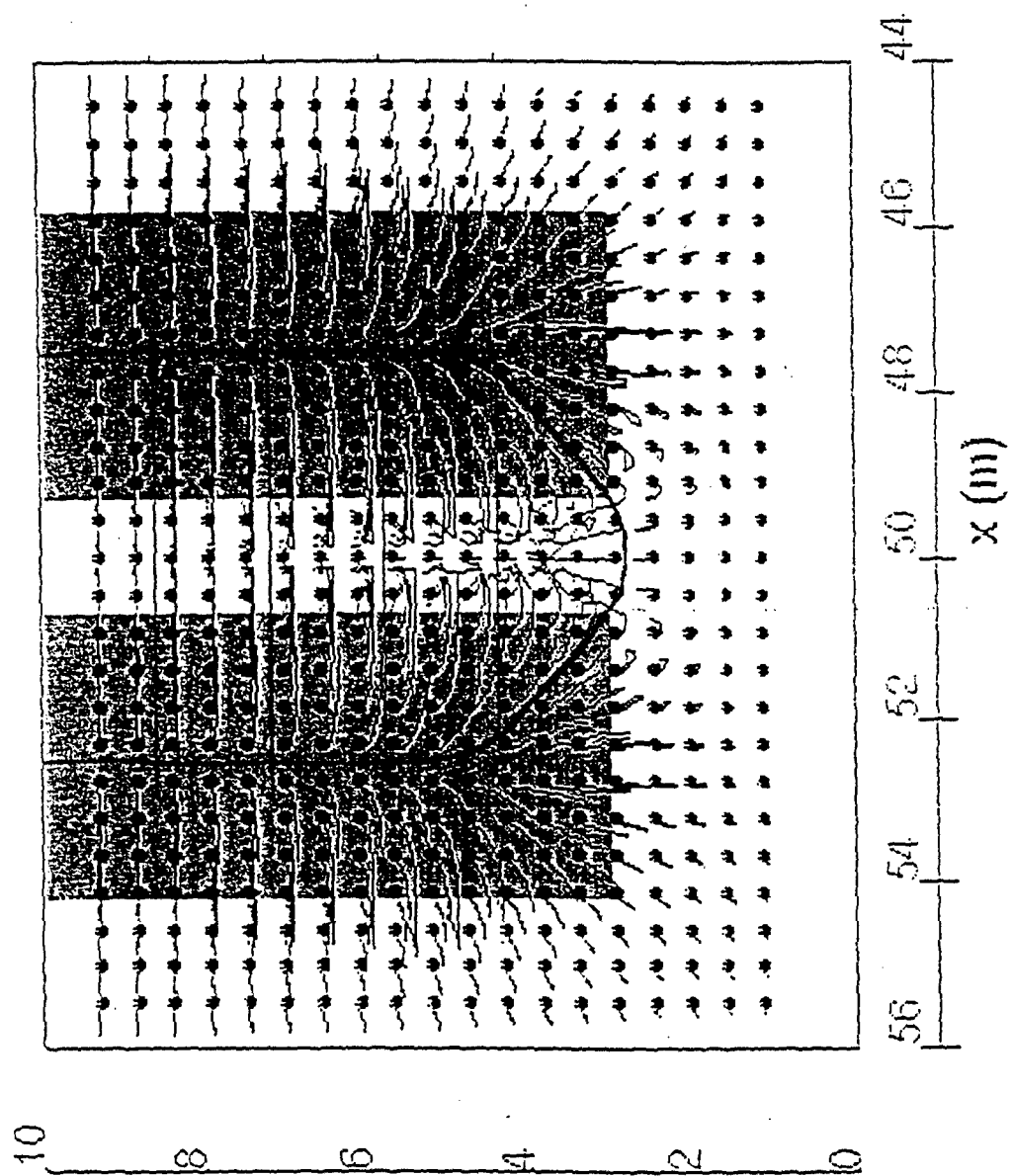

Figure 15. Streamlines and Capture Zone for Run #6 of Run Matrix.

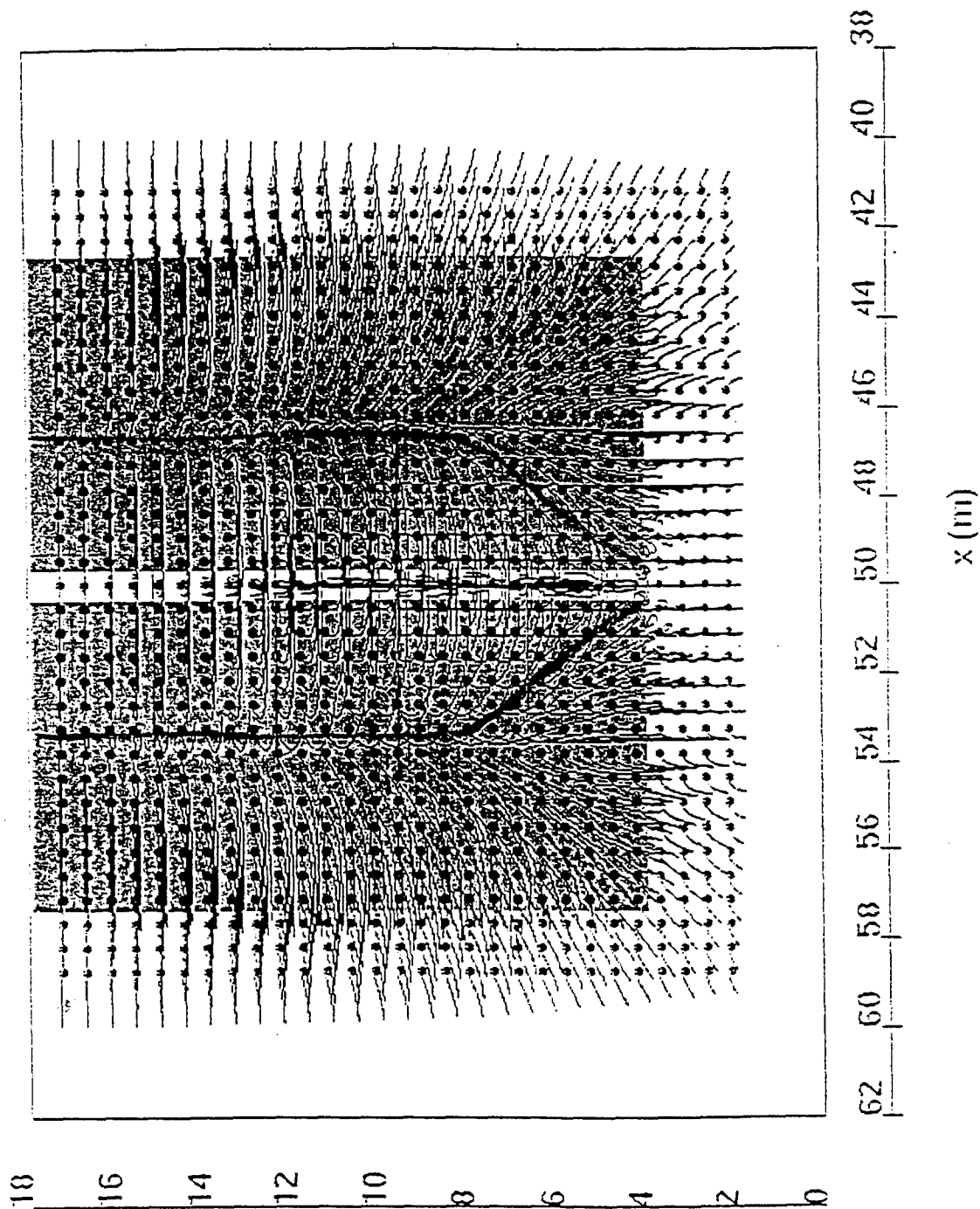

Figure 16. Streamlines and Capture Zone for Run #7 of Run Matrix.

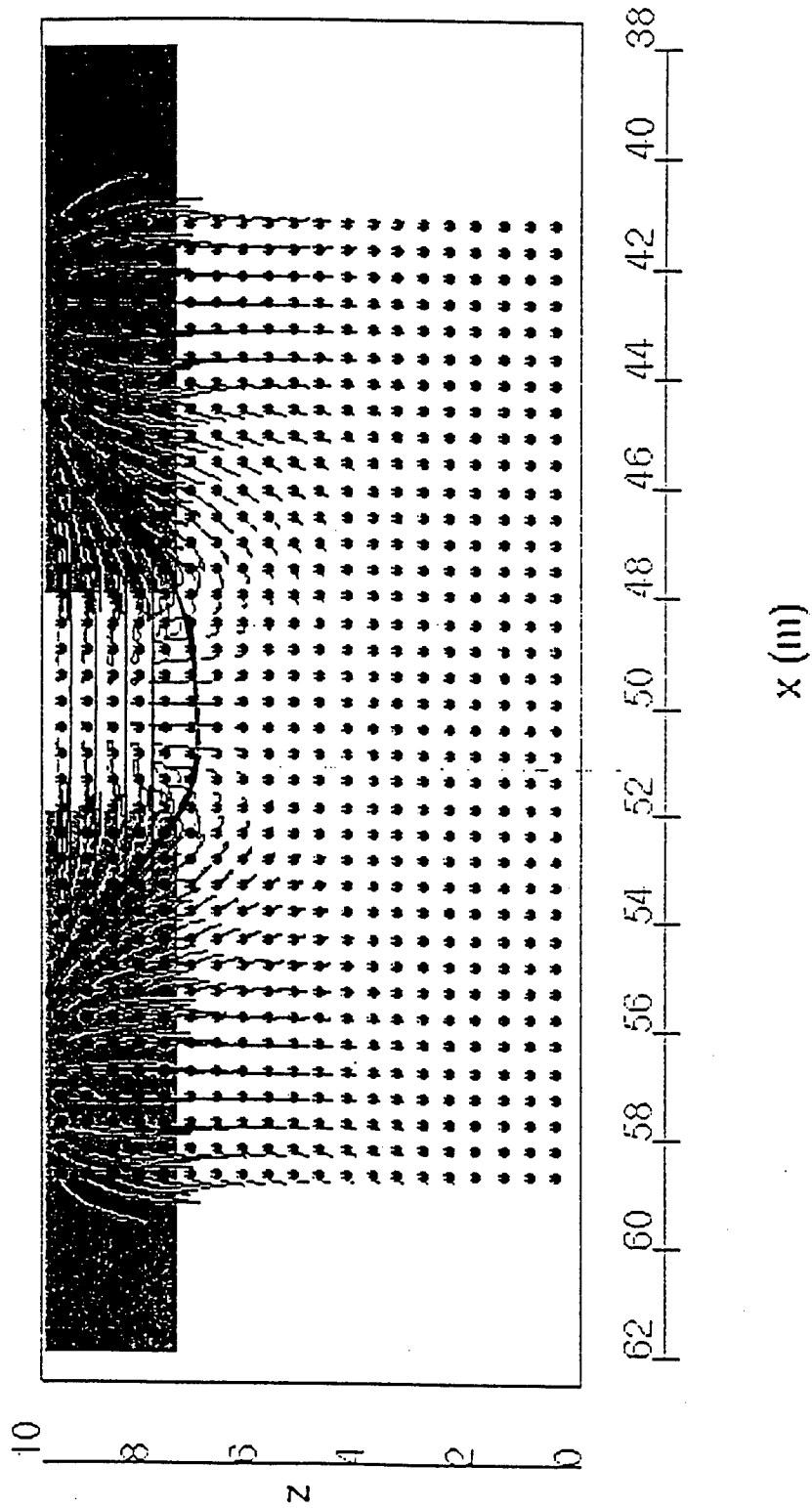
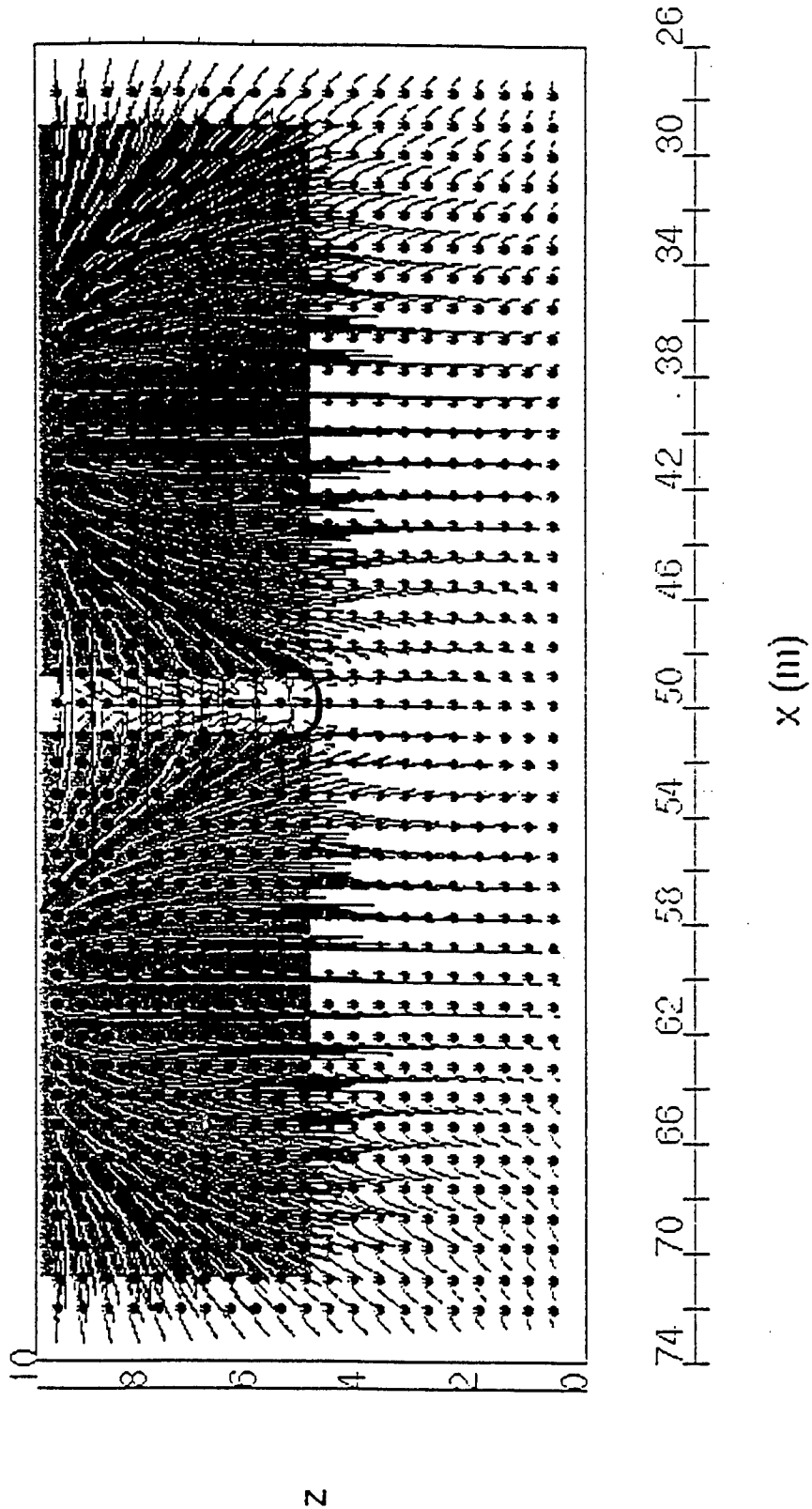
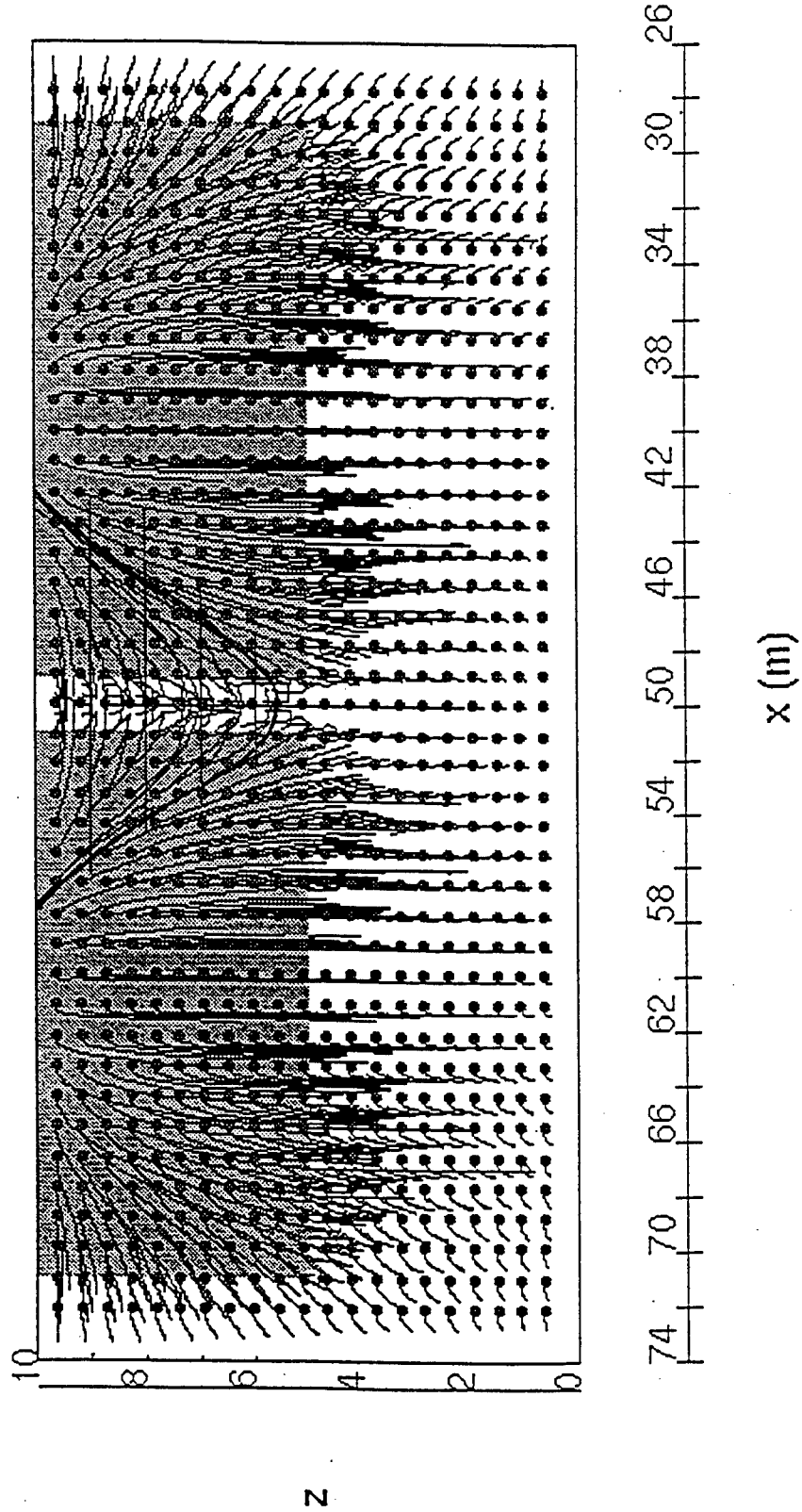

Figure 17. Streamlines and Capture Zone for Run #8 of Run Matrix.



Note: Vertical exaggeration = 2.0

Figure 18. Streamlines and Capture Zone for Run #9 of Run Matrix.



Note: Vertical exaggeration = 2.0

Figure 19. Streamlines and Capture Zone for Run #10 of Run Matrix.

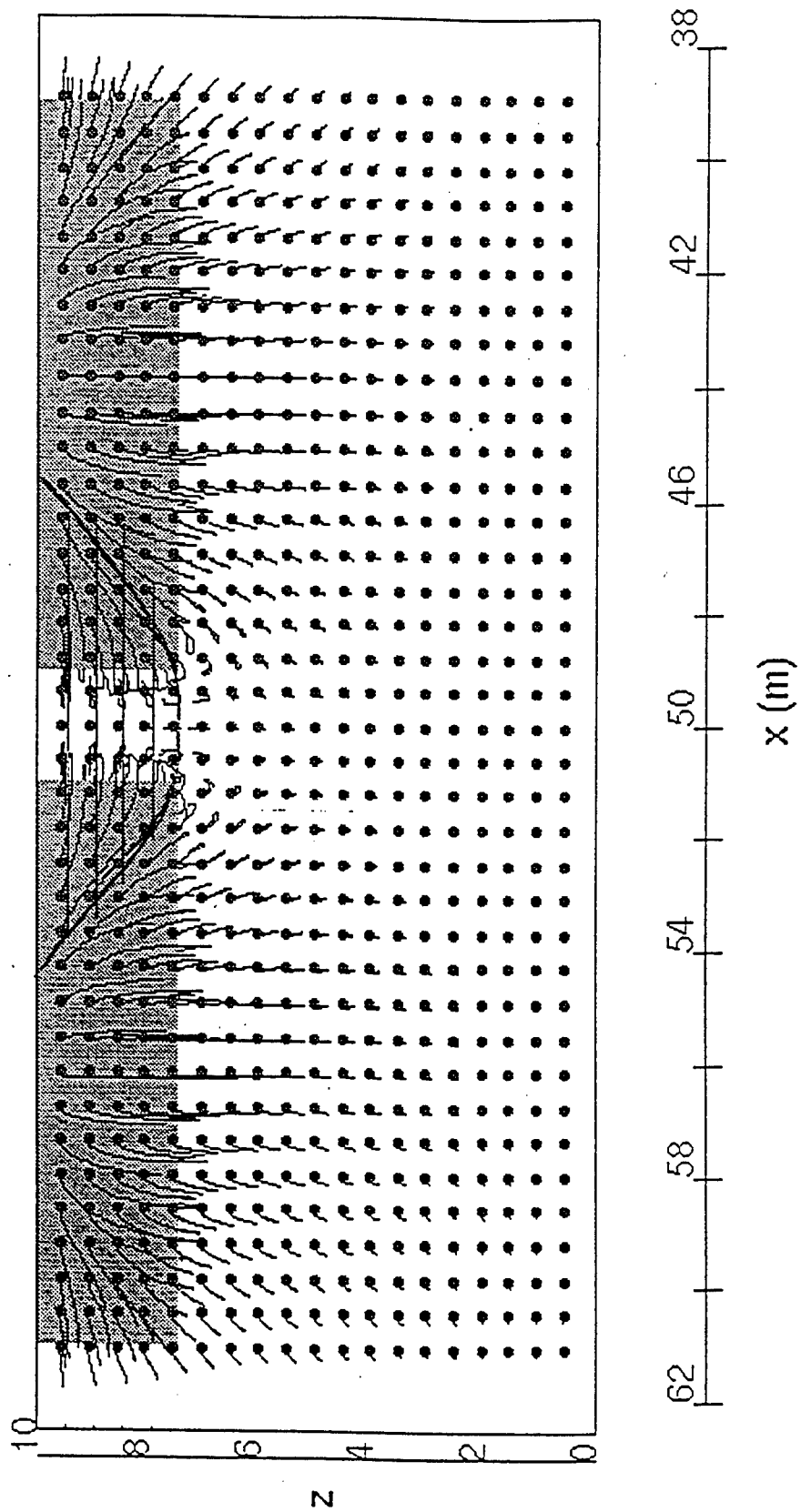

Figure 20. Streamlines and Capture Zone for Run #11 of Run Matrix.

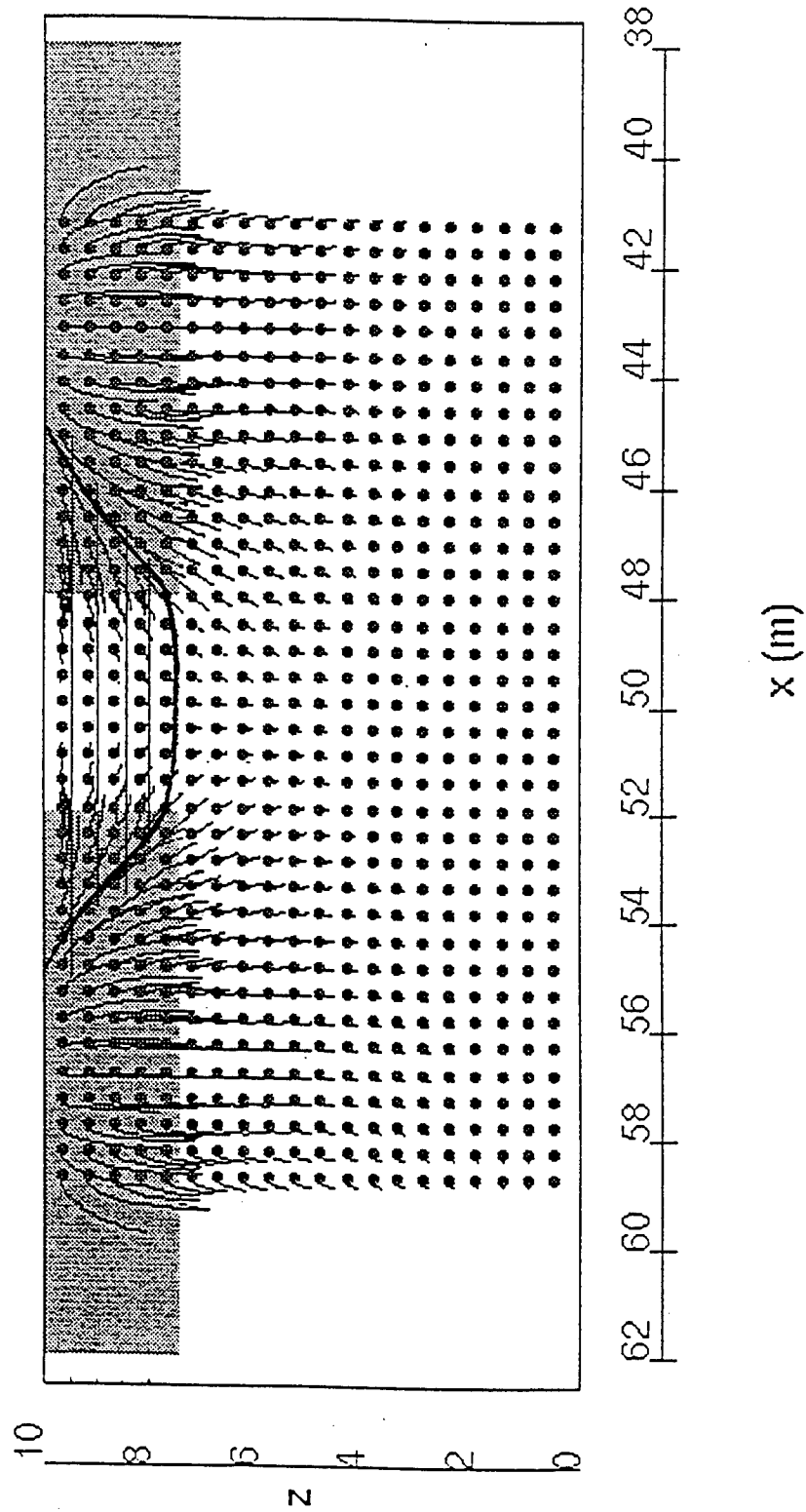

Figure 21. Streamlines and Capture Zone for Run #12 of Run Matrix.

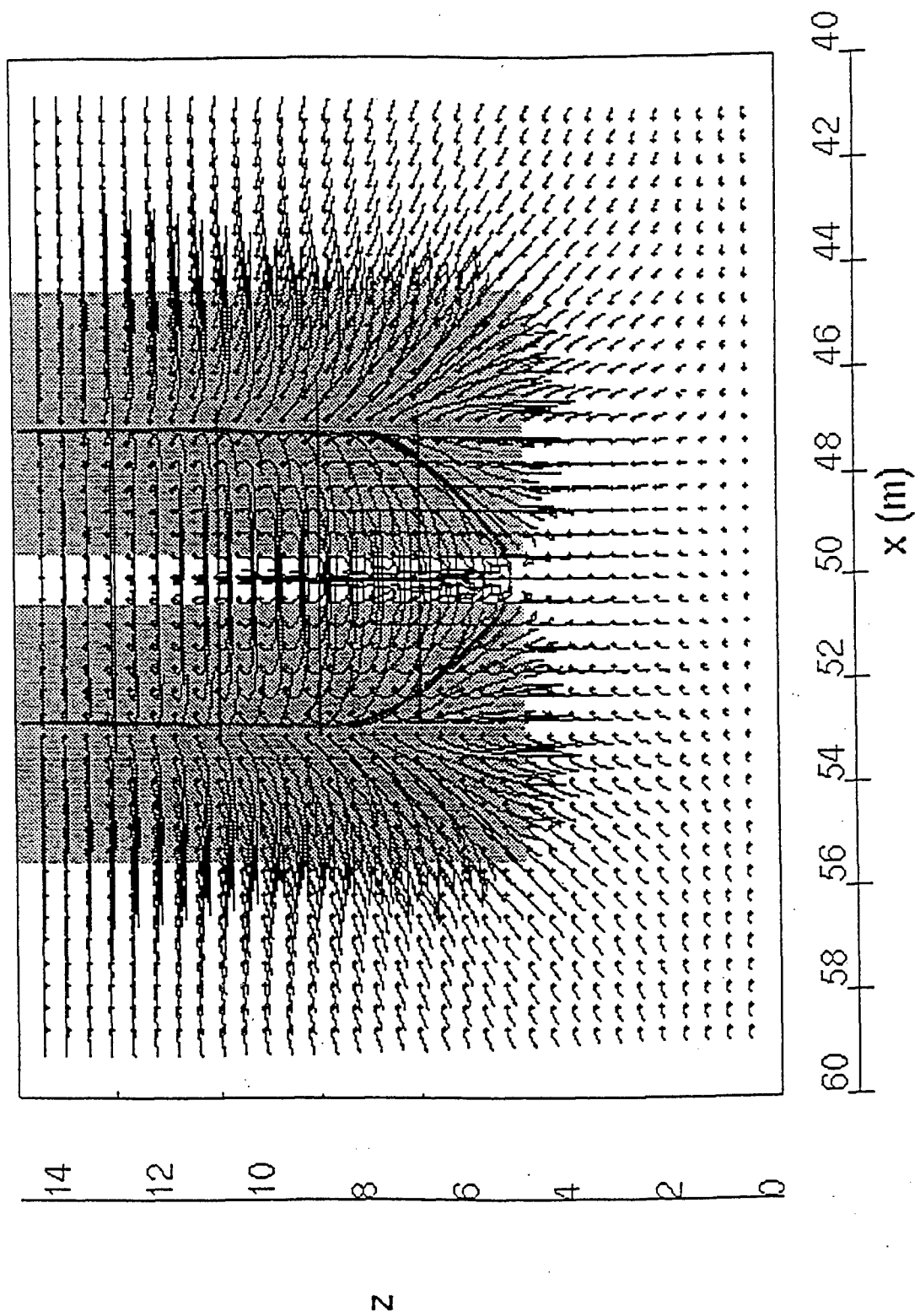

Figure 22. Streamlines and Capture Zone for Run #13 of Run Matrix.

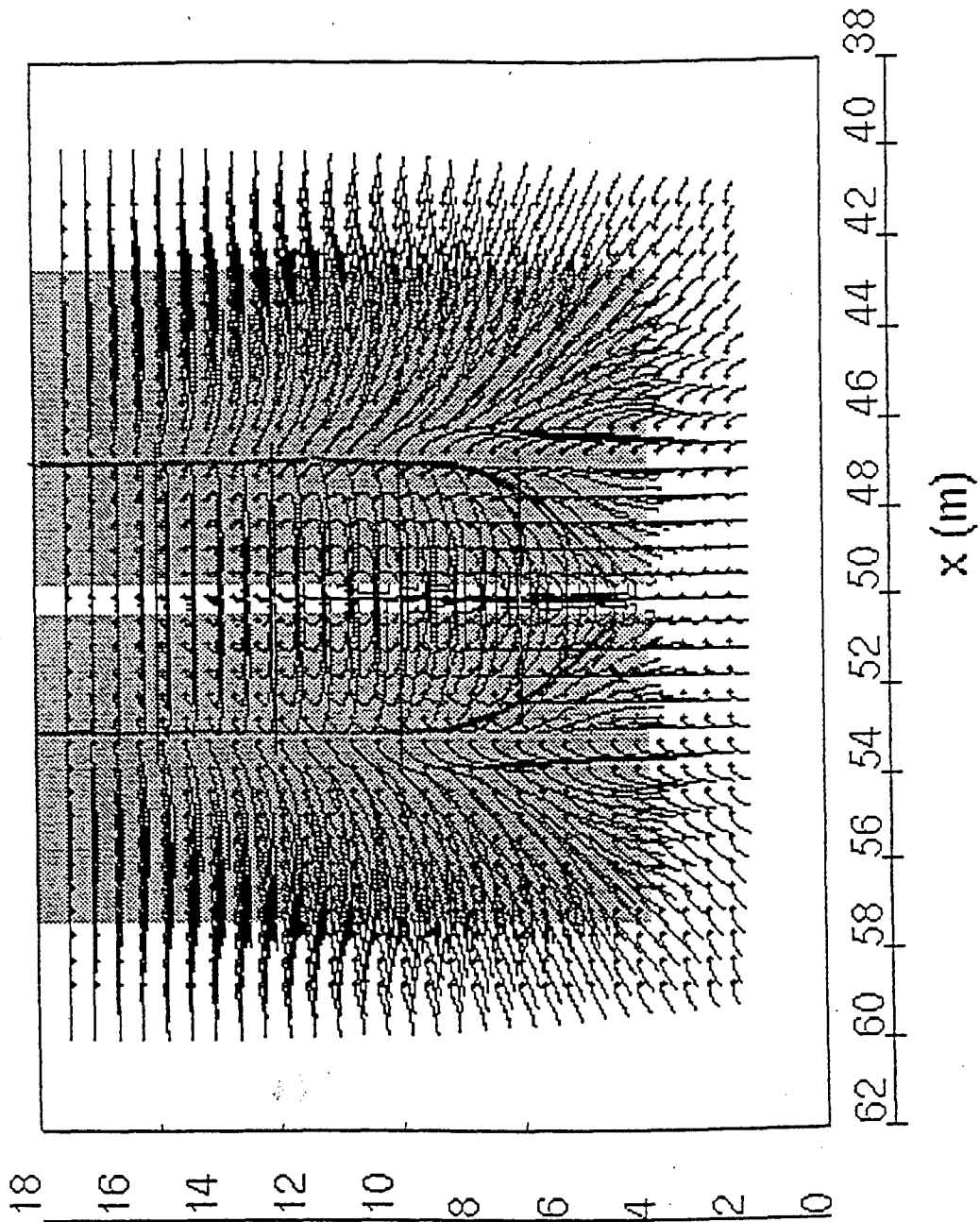

Figure 23. Streamlines and Capture Zone for Run #14 of Run Matrix.

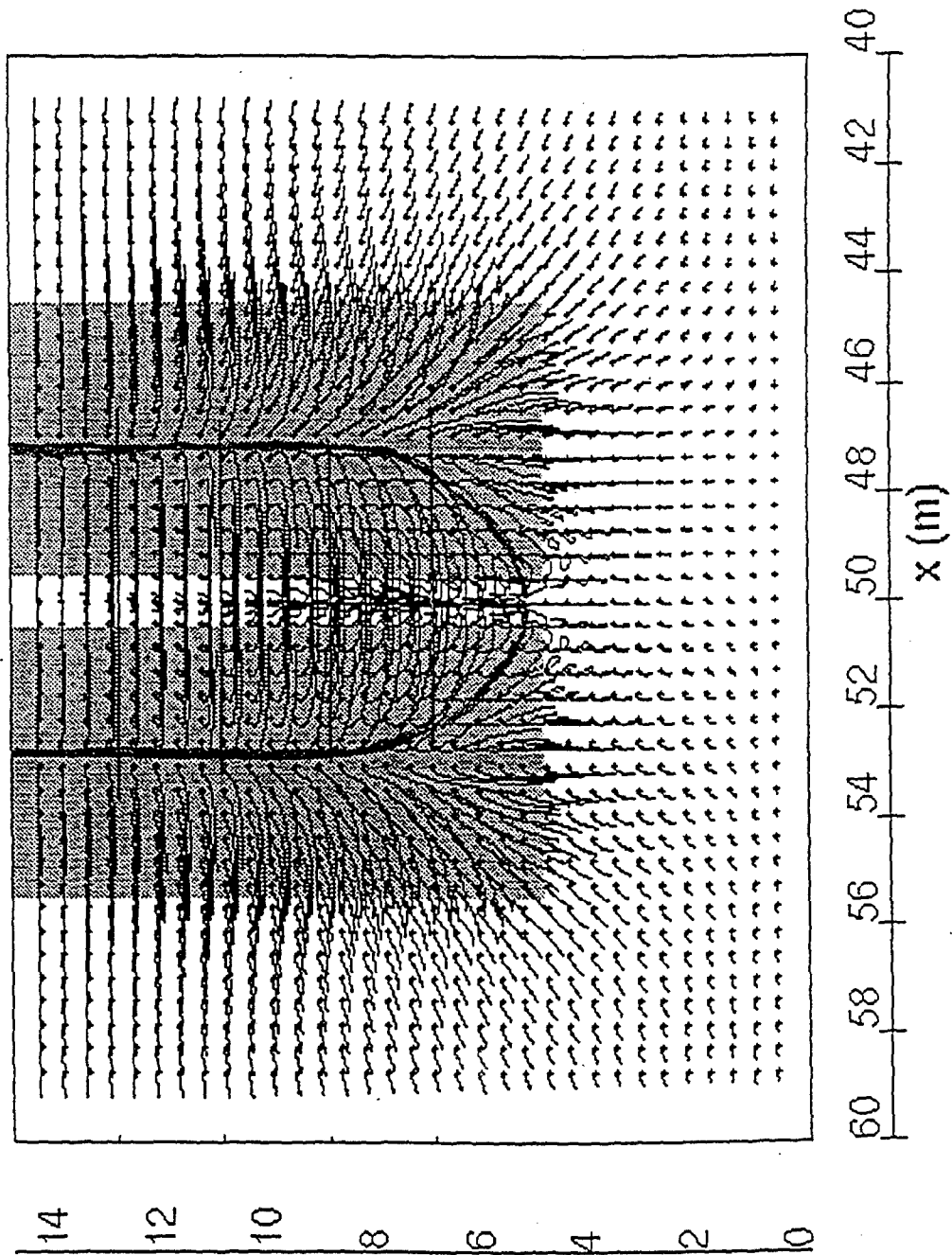

Figure 24. Streamlines and Capture Zone for Run #15 of Run Matrix.

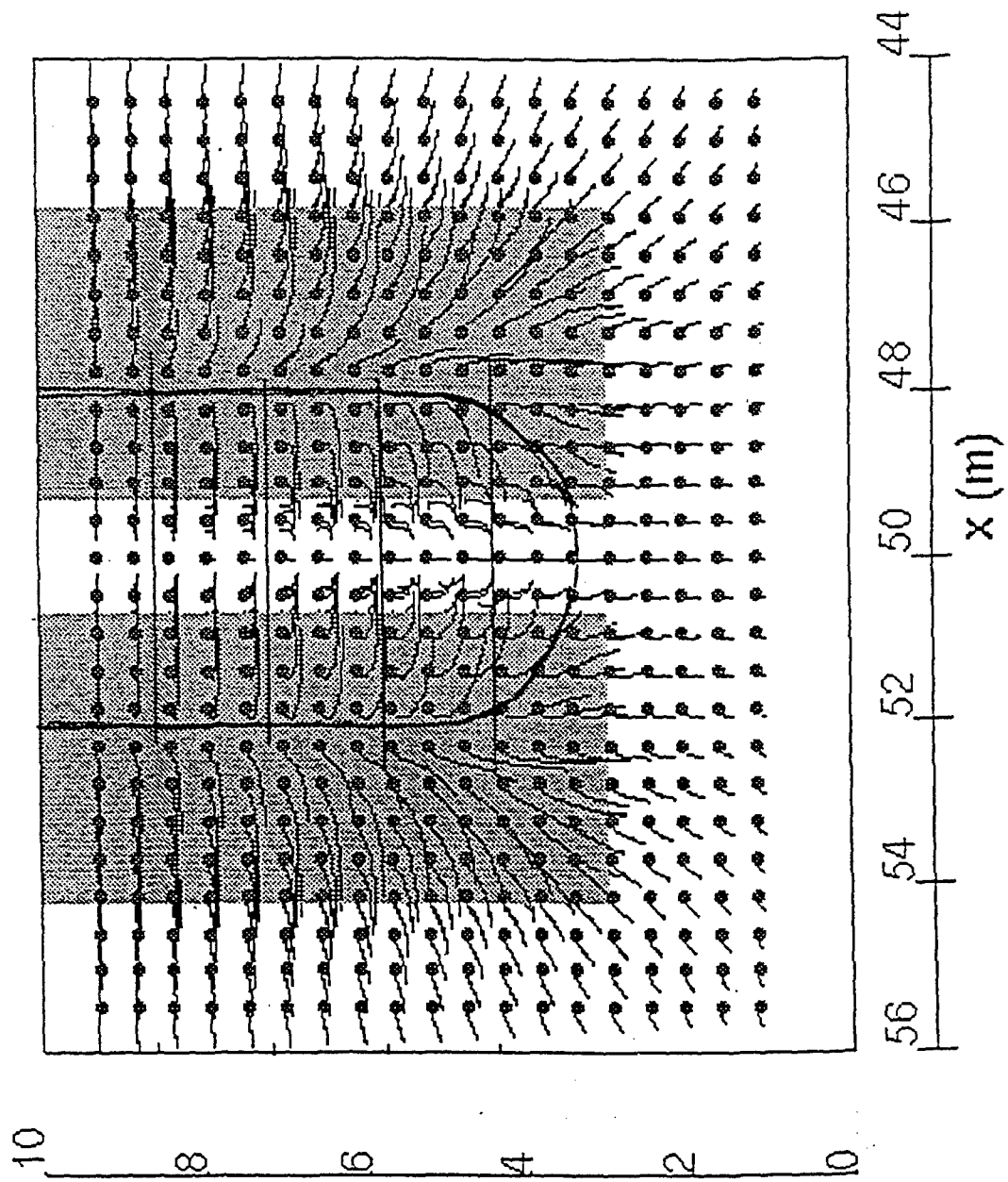

Figure 25. Streamlines and Capture Zone for Run #16 of Run Matrix.

APPENDIX A

SUPPLEMENTARY OUTPUT - CASE 1 (OF COMPARISON CASES)

Function: Hydraulic Head
Set: Contours 10.0 to 10.25 by 0.005 (flow Top to Bot)
Slice at: 9.5
Data set: ara-10

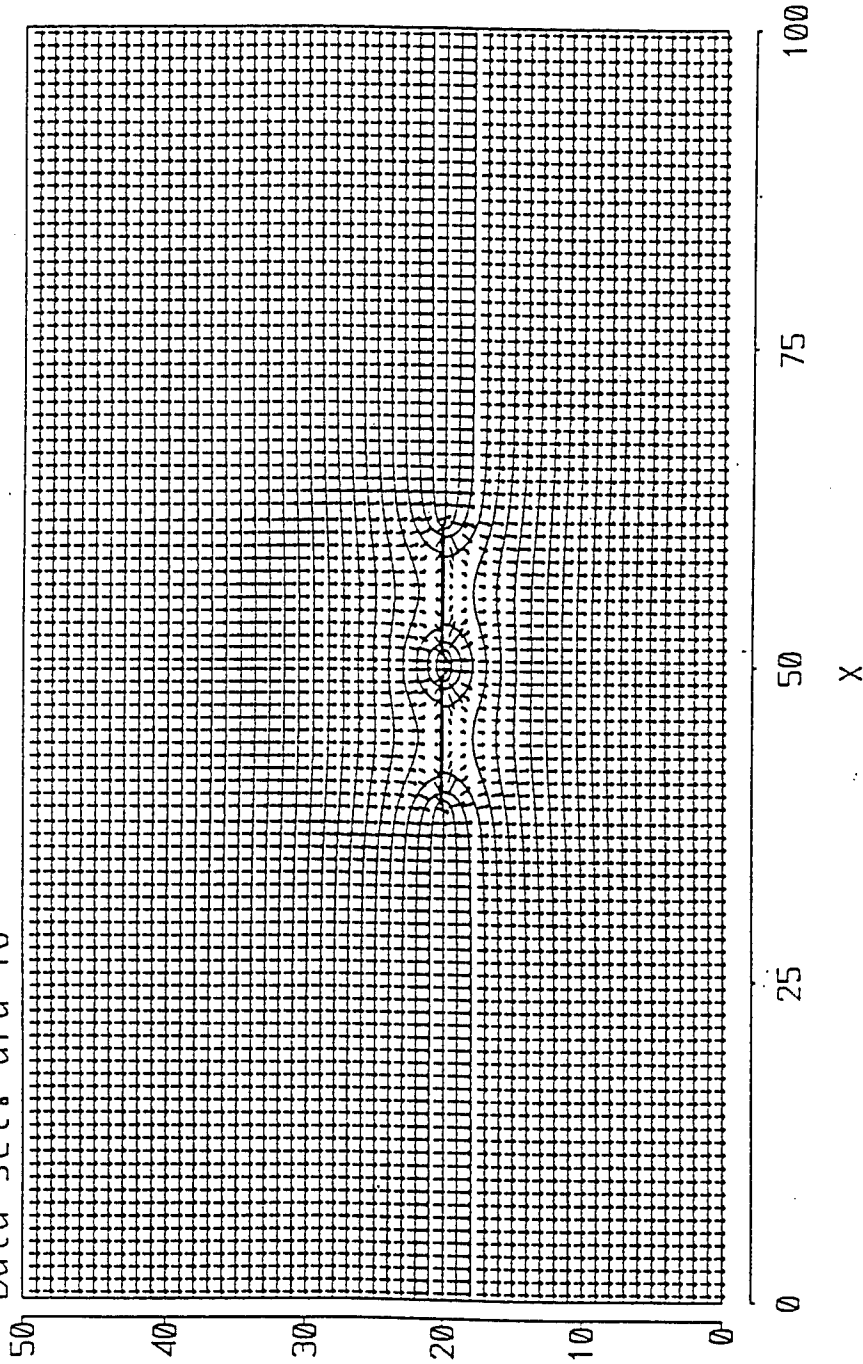

Figure A-1. XY Slice of Hydraulic Head and Velocities, Z = 9.5 Meters.

Function: Hydraulic Head
Set : Contours 10.0 to 10.25 by 0.005 (flow Top to Bot)
Slice at: 5.0
Data set: ara-10

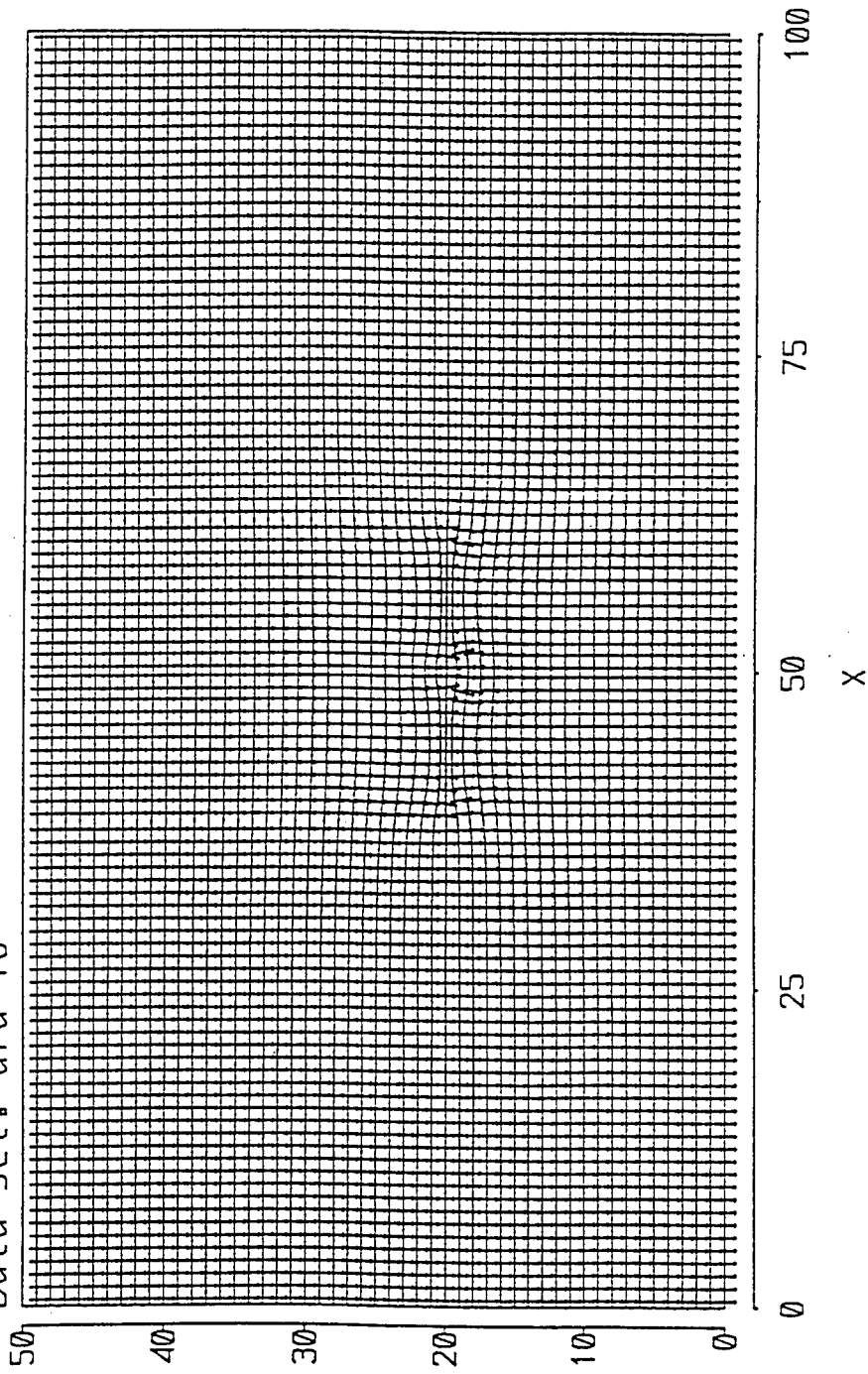

Figure A-2. XY Slice of Hydraulic Head and Velocities, Z = 5.0 Meters.

Function: Hydraulic Head
Set : Contours 10.0 to 10.25 by 0.005 (flow R to L)
Slice at: 50.0
Data set: ara-10

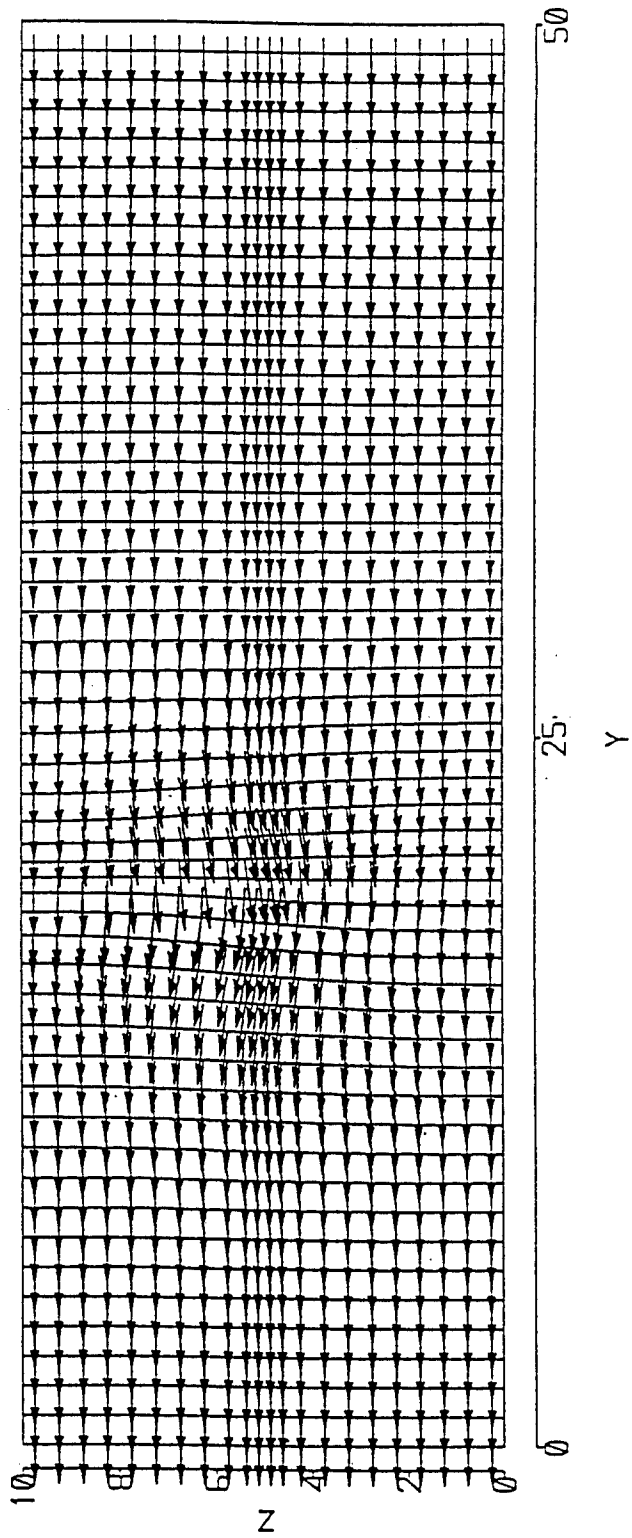

Figure A-3. YZ Slice of Hydraulic Head and Velocities, X = 50.0 Meters (Through Gate).

Function: Hydraulic Head
Set : Contours 10.0 to 10.25 by 0.005 (flow R to L)
Slice at: 44.0
Data set: ara-1a

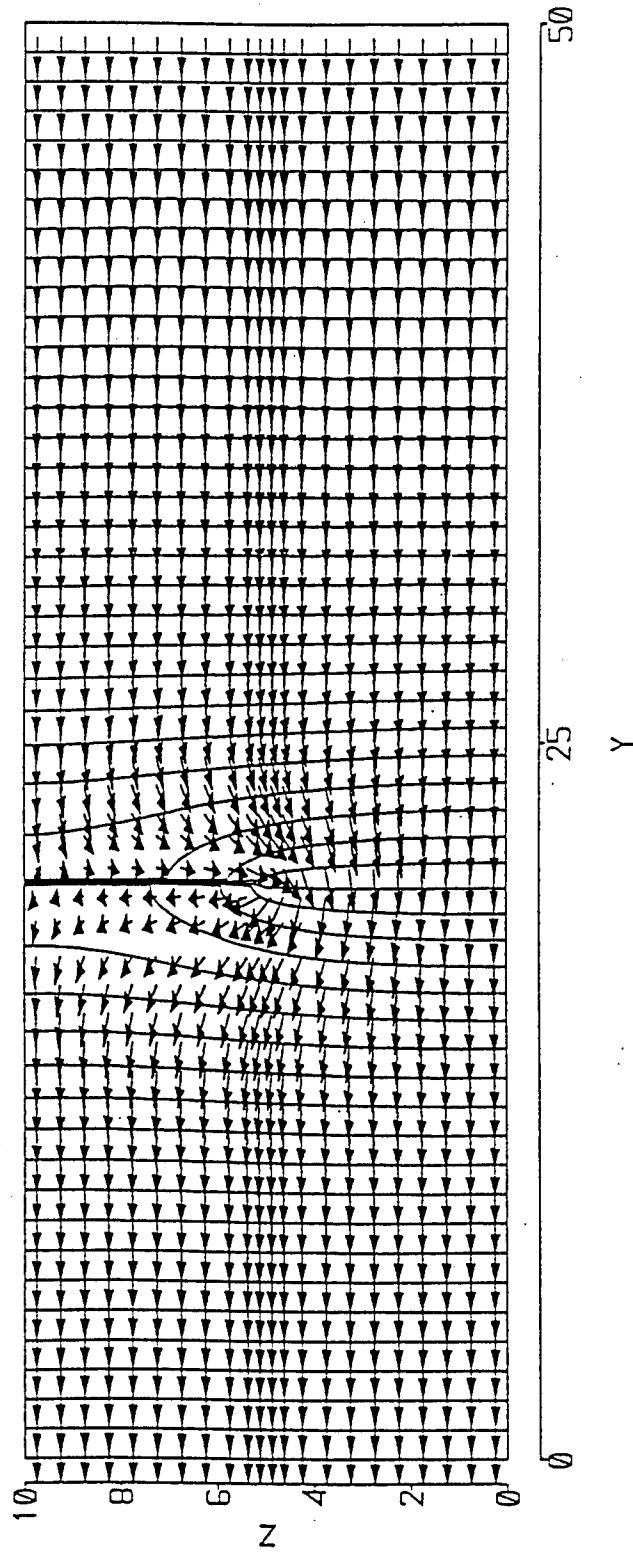

Figure A-4. YZ Slice of Hydraulic Head and Velocities, X = 44.0 Meters (Through Cutoff Wall).

Function: Hydraulic Head
Set : Contours 10.0 to 10.25 by 0.005 (flow R to L)
Slice at: 40.0
Data set: ara-10

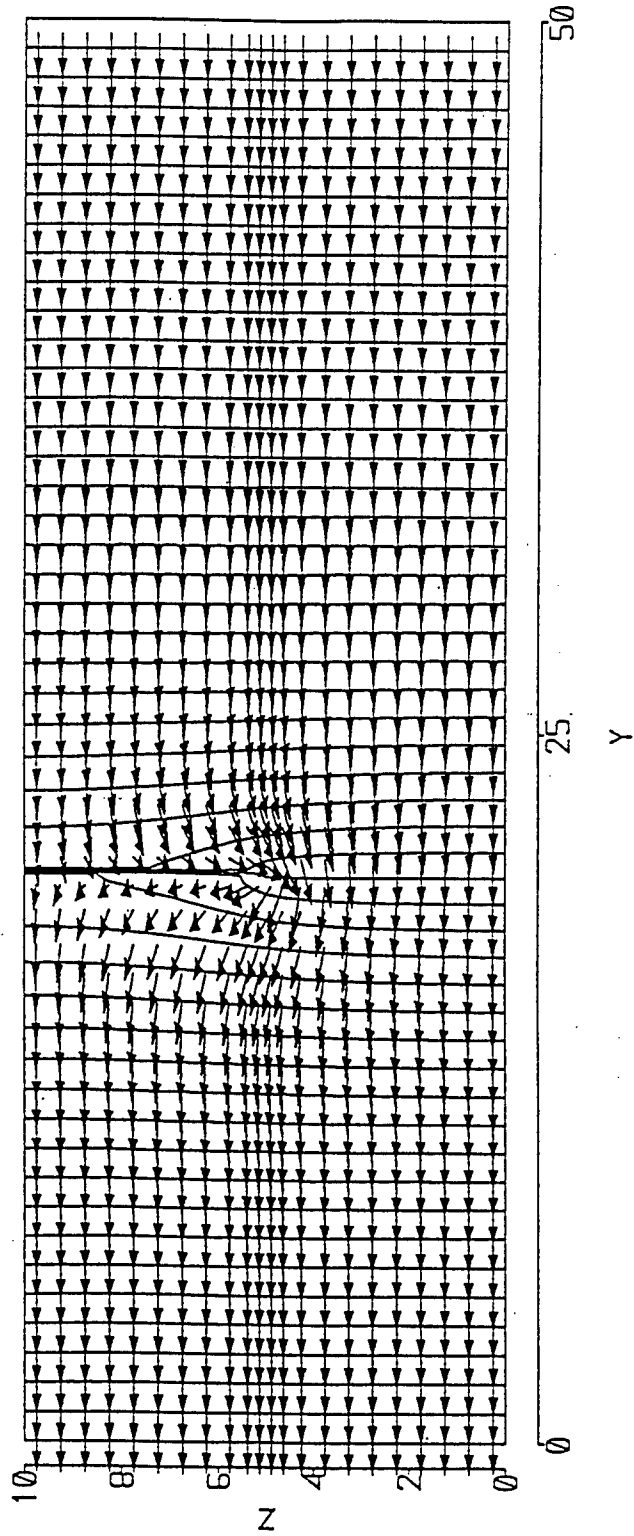

Figure A-5. YZ Slice of Hydraulic Head and Velocities, X = 40.0 Meters (Through Cutoff Wall).

APPENDIX B

SUPPLEMENTARY OUTPUT - CASE 2 (OF COMPARISON CASES)

Function: Pressure Head
Set : Water Table (Pressure head = 0.0)
Slice at: 44.0
Data set: ara-20

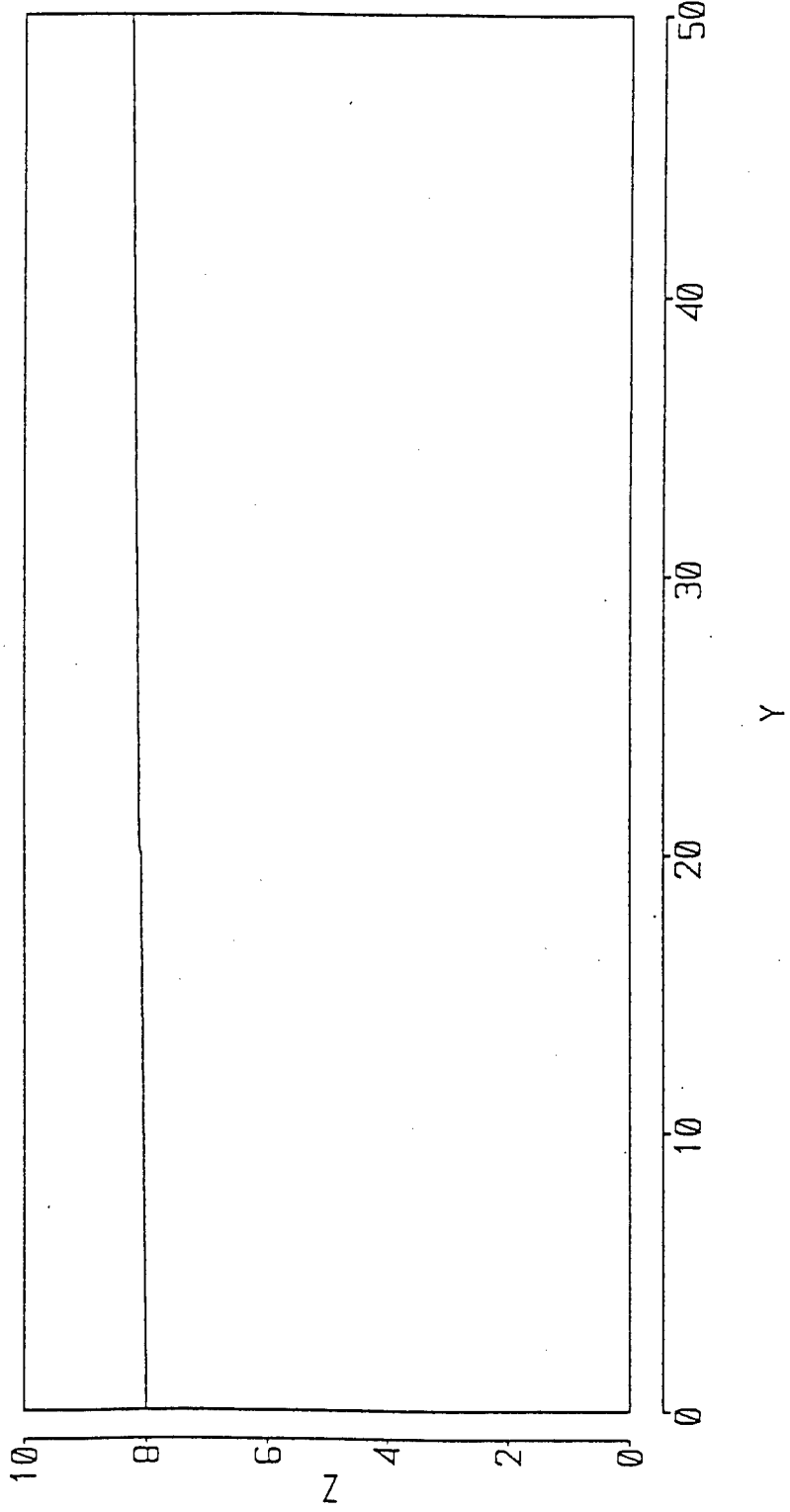

Figure B-1. YZ Slice of Pressure Head (Water Table), X = 44.0 Meters (Through Cutoff Wall).

Function: Pressure Head
Set : Water Table (Pressure head = 0.0)
Slice at: 50.0
Data set: ara-20

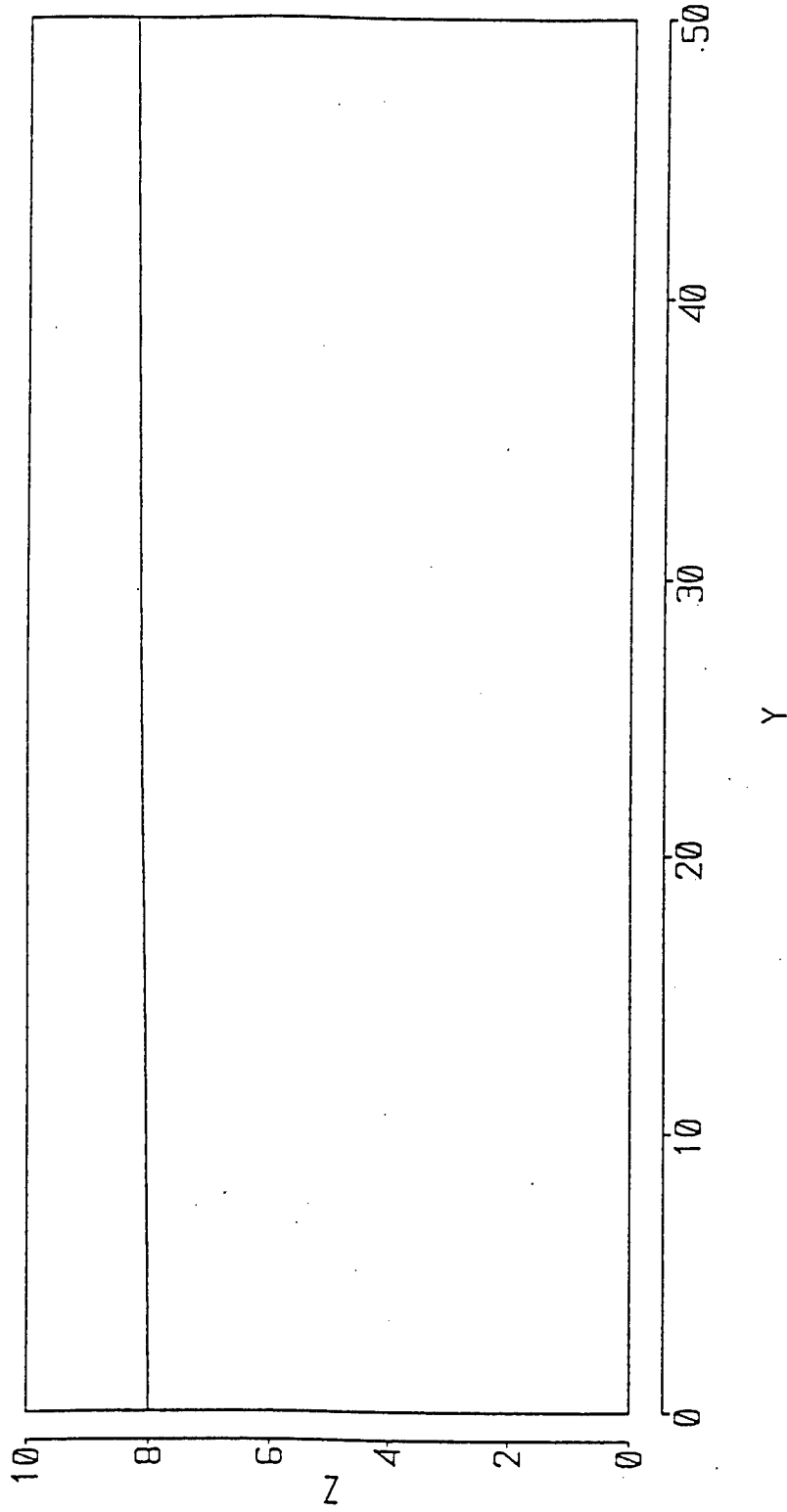

Figure B-2. YZ Slice of Pressure Head (Water Table), X = 50.0 Meters (Through Gate).

Function: Hydraulic Head
Set : Contours 8.0 to 8.25 by 0.005 (flow Top to Bot)
Slice at: 9.5
Data set: ara-20

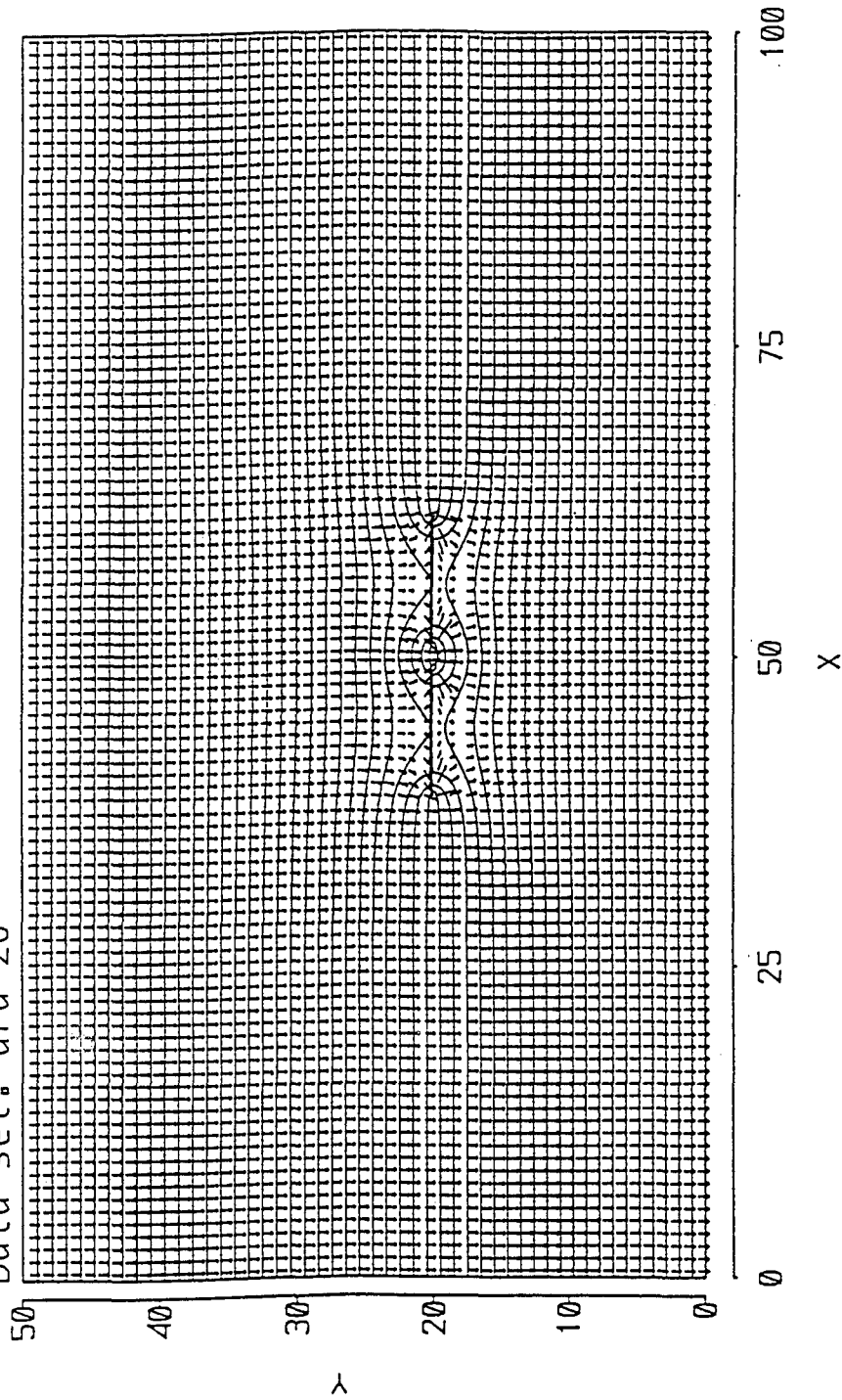

Figure B-3. XY Slice of Hydraulic Head and Velocities, Z = 9.5 Meters.

Function: Hydraulic Head
Set : Contours 8.0 to 8.25 by 0.005 (flow Top to Bot)
Slice at: 5.0
Data set: ara-20

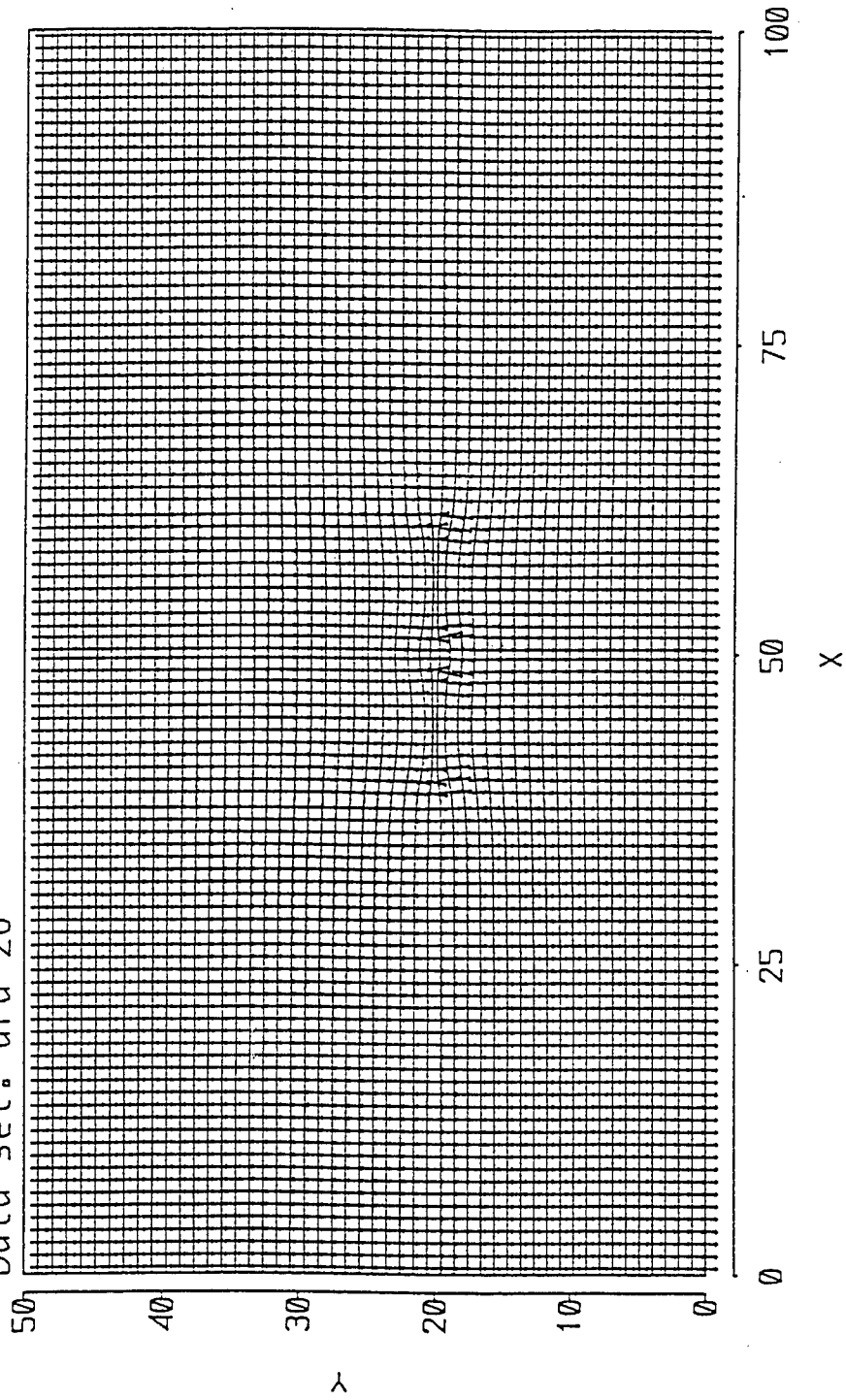

Figure B-4. XY Slice of Hydraulic Head and Velocities, Z = 5.0 Meters.

Function: Hydraulic Head
Set : Contours 8.0 to 8.25 by 0.005 (flow R to L)
Slice at: 50.0
Data set: ara-20

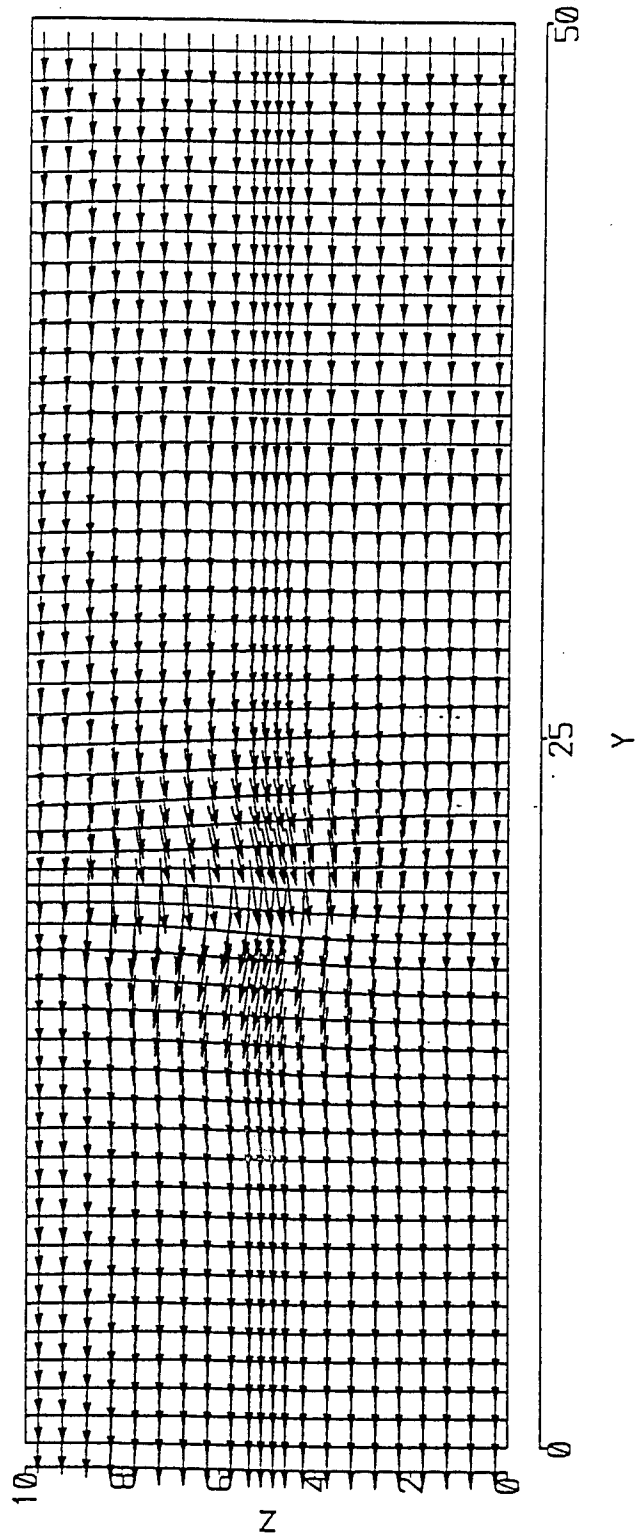

Figure B-5. YZ Slice of Hydraulic Head and Velocities, X = 50.0 Meters (Through Gate).

Function: Hydraulic Head
Set : Contours 8.0 to 8.25 by 0.005 (flow R to L)
Slice at: 44.0
Data set: ara-20

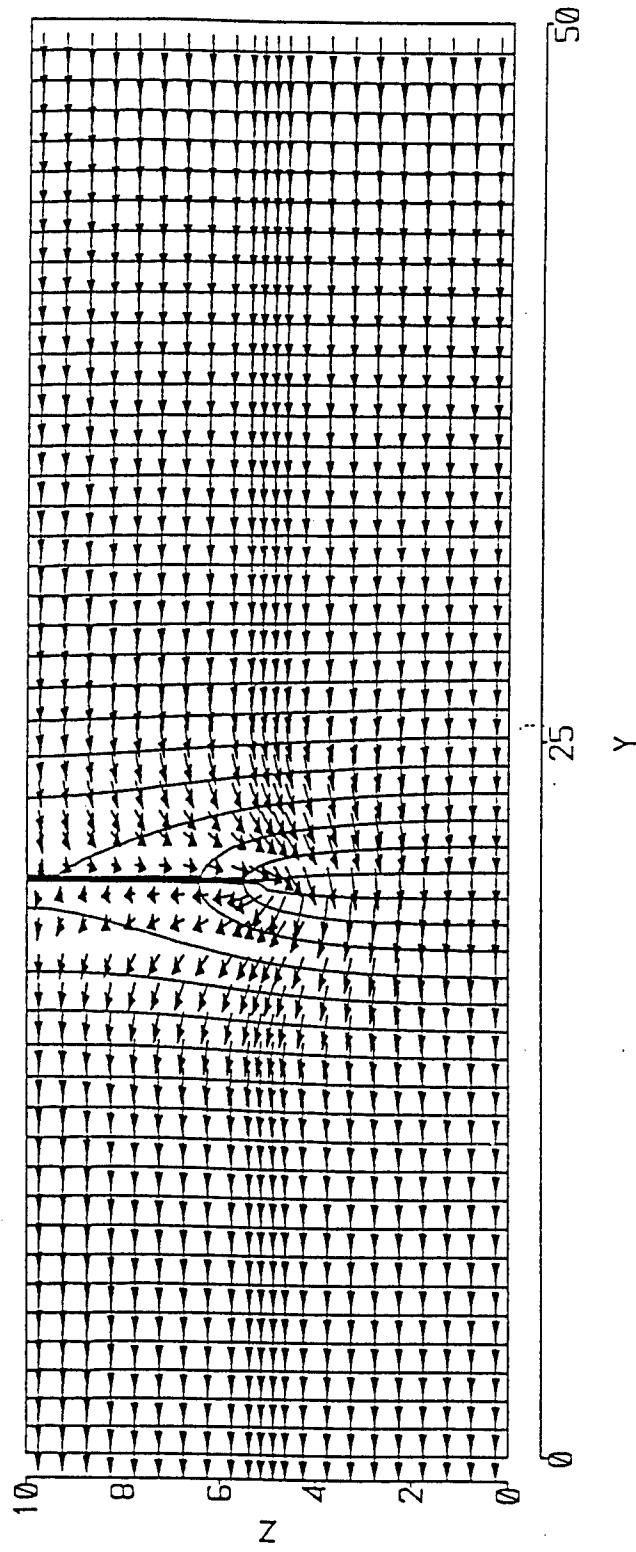

Figure B-6. YZ Slice of Hydraulic Head and Velocities, X = 44.0 Meters (Through Cutoff Wall).

Function: Hydraulic Head
Set : Contours 8.0 to 8.25 by 0.005 (flow R to L)
Slice at: 40.0
Data set: ara-20

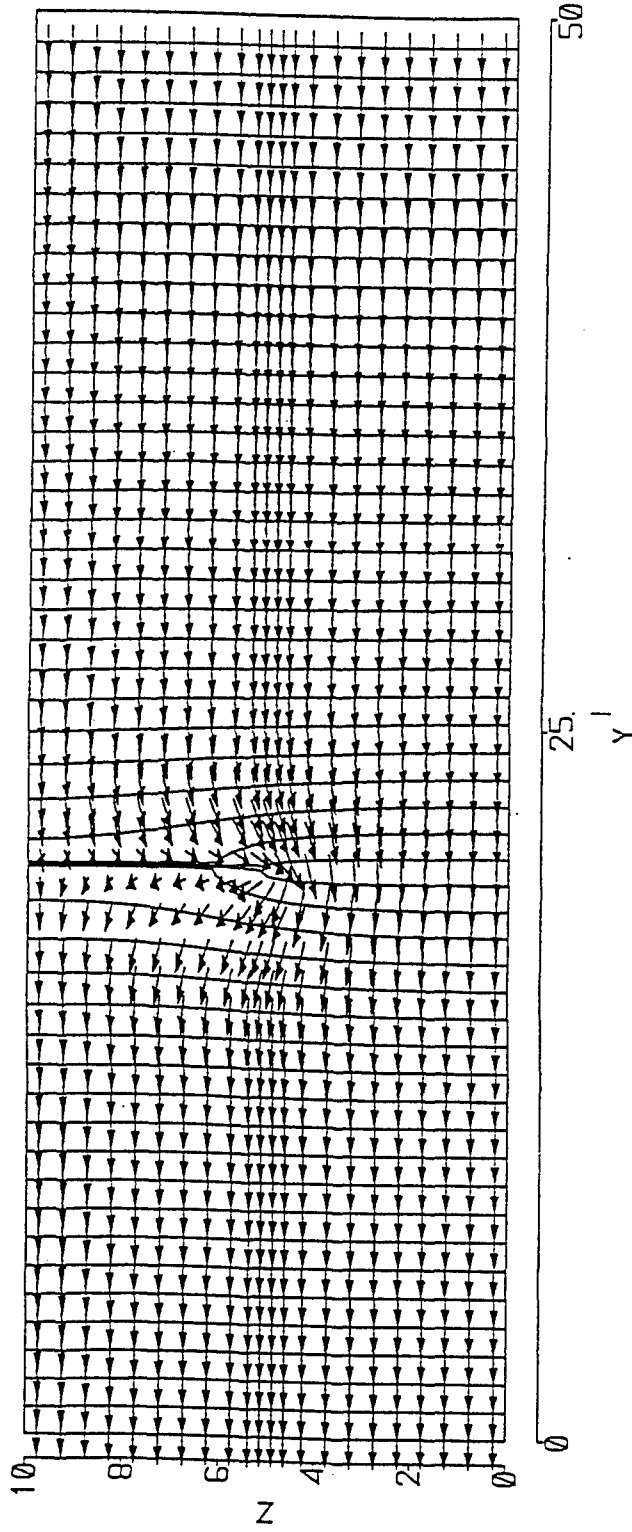

Figure B-7. YZ Slice of Hydraulic Head and Velocities, X = 40.0 Meters (Through Cutoff Wall).

APPENDIX C

SUPPLEMENTARY OUTPUT - CASE 3 (OF COMPARISON CASES)

Function: Hydraulic Head
Set : Contours 10.0 to 10.25 by 0.005 (flow Top to Bot)
Slice at: 9.5
Data set: ara-50

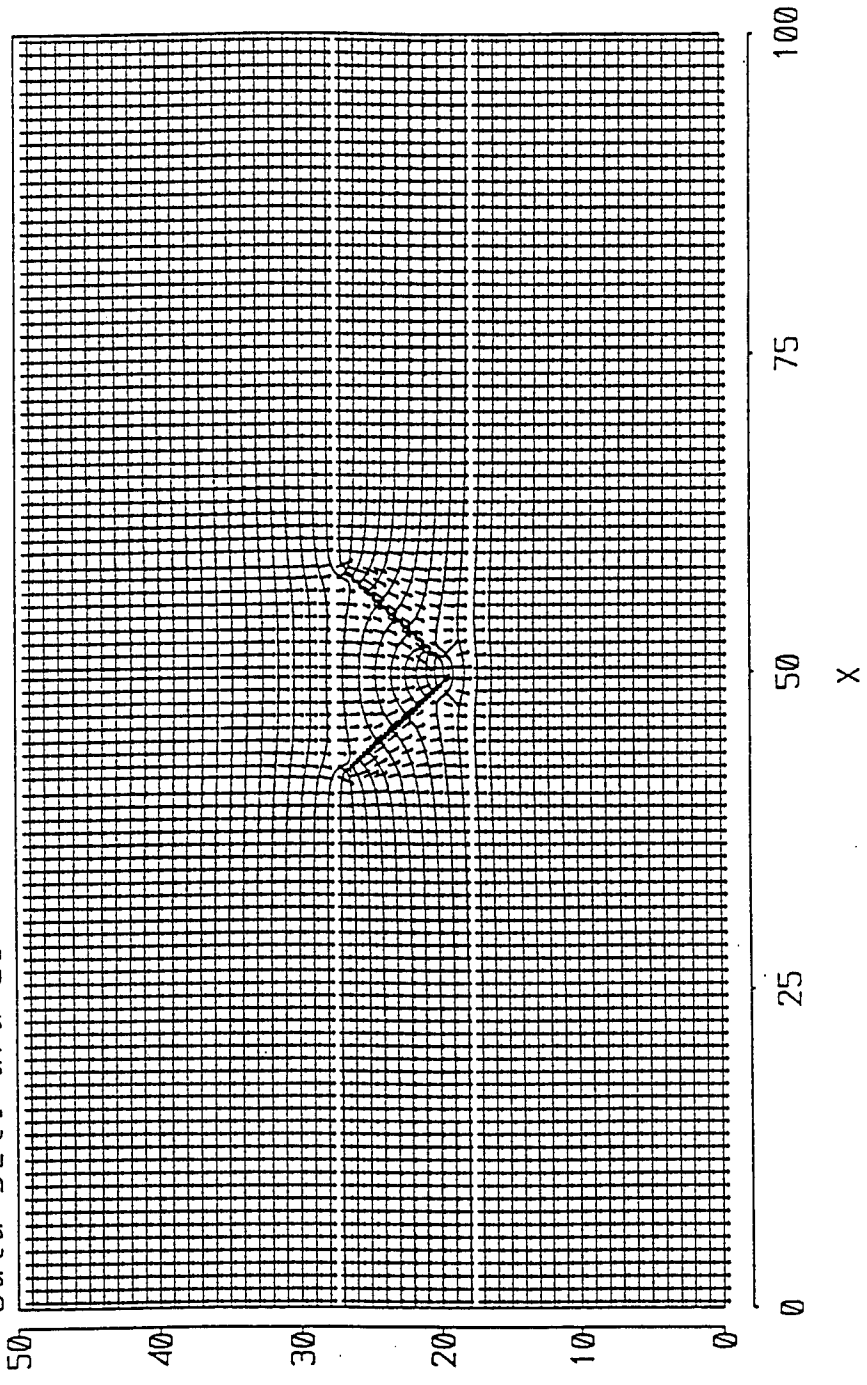

Figure C-1. XY Slice of Hydraulic Head and Velocities, Z = 9.5 Meters.

Function: Hydraulic Head
Set : Contours 10.0 to 10.25 by 0.005 (flow Top to Bot)
Slice at: 5.0
Data set: ara-50

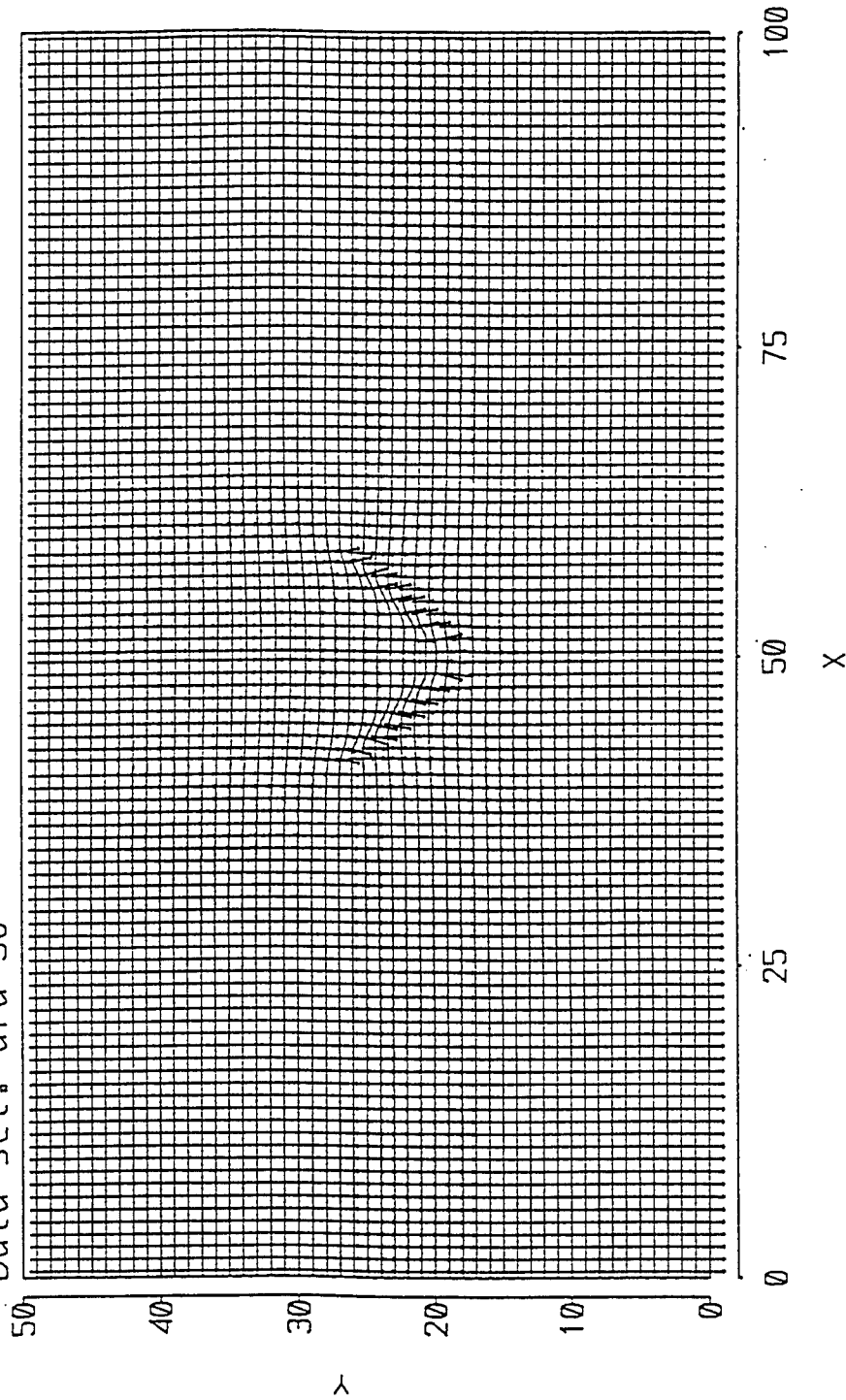

Figure C-2. XY Slice of Hydraulic Head and Velocities, Z = 5.0 Meters.

Function: Hydraulic Head
Set : Contours 10.0 10.25 by 0.005 (flow R to L)
Slice at: 50.0
Data set: ara-50

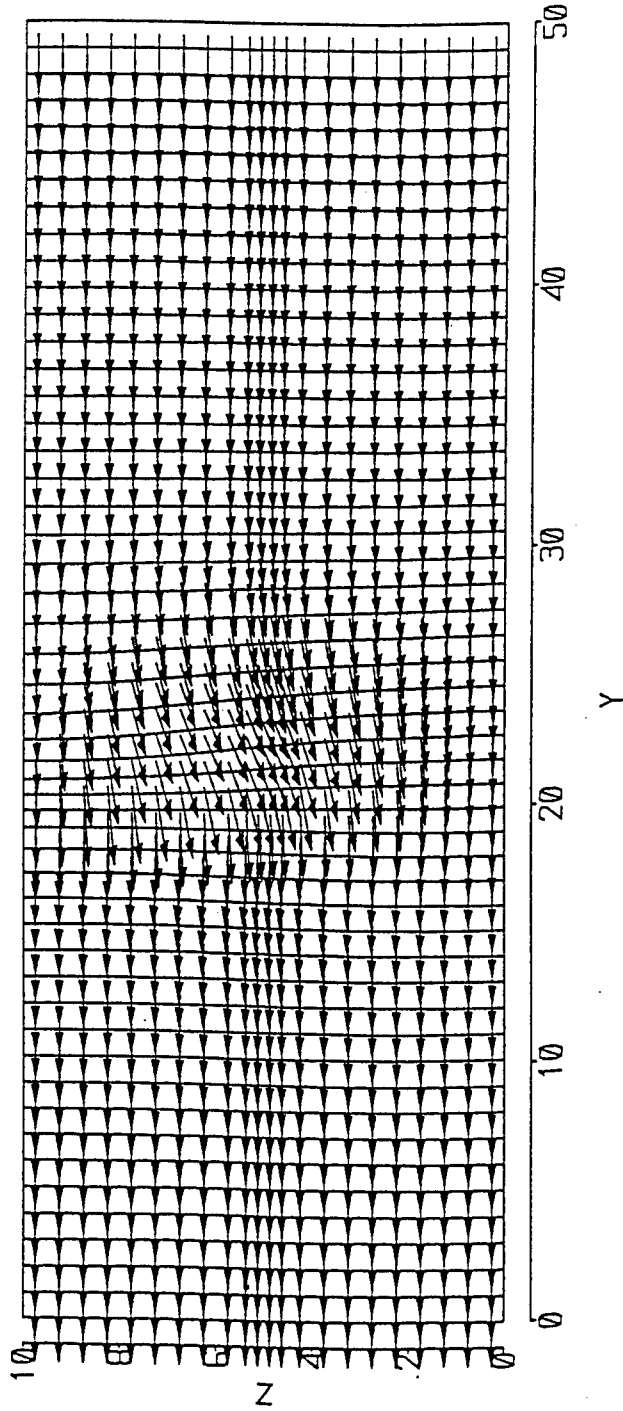

Figure C-3. YZ Slice of Hydraulic Head and Velocities, X = 50.0 Meters (Through Gate).

Function: Hydraulic Head
Set : Contours 10.0 to 10.25 by 0.005 (flow R to L)
Slice at: 47.0
Data set: ara-50

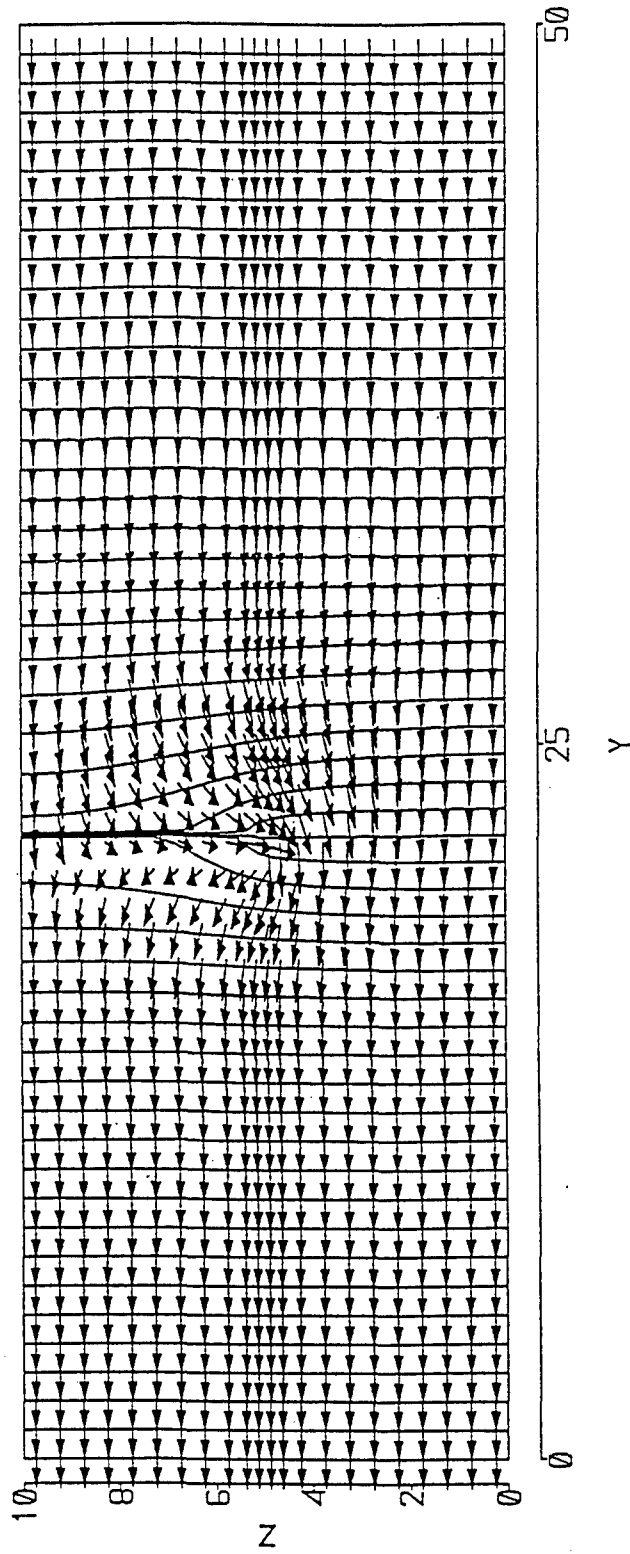

Figure C-4. YZ Slice of Hydraulic Head and Velocities, X = 47.0 Meters (Through Cutoff Wall).

Function: Hydraulic Head
Set : Contours 10.0 to 10.25 by 0.005 (flow R to L)
Slice at: 44.0
Data set: ara-50

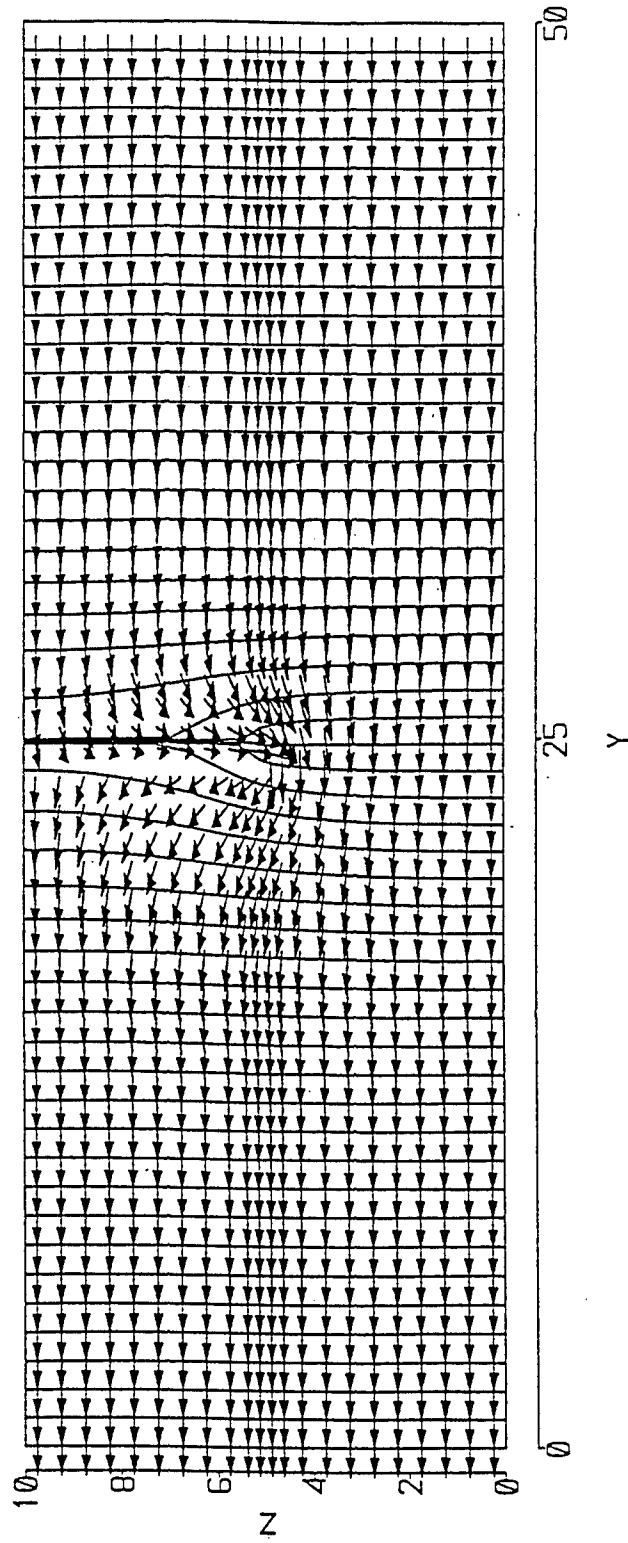

Figure C-5. YZ Slice of Hydraulic Head and Velocities, X = 44.0 Meters (Through Cutoff Wall).