



US Army Corps
of Engineers

Construction Engineering
Research Laboratories

USACERL Technical Report 97/87
June 1997

The Use of Direct Digital Controls in Utility Systems at Army Installations

A Review of Current Technologies

by
David M. Underwood and Alfonso C. Guativa

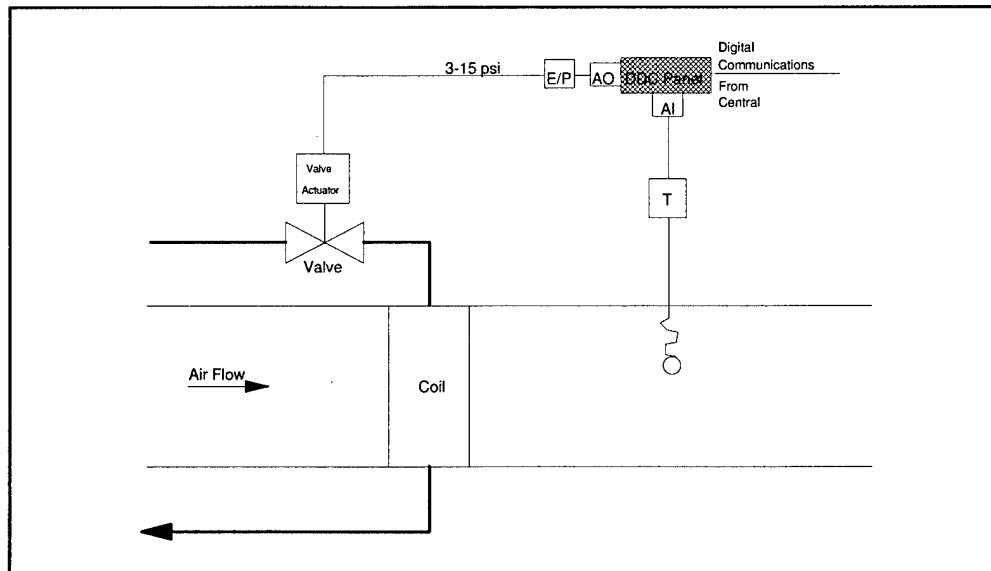

19970715 221

This study identified and investigated four major types of microprocessor-based control hardware to determine their possible application to Army utilities; (1) Programmable Logic Controllers (PLCs); (2) Single Loop Digital Controllers (SLDCs); (3) Commercial Direct Digital Controls; and (4) STD and VME bus-based controls. Variables such as cost, ease of use, programming

requirements, and maintenance requirements were evaluated.

Commercial DDC, SLDC, and PLC were found to have features most useful to Army utilities. The study recommended further research in the form of demonstration projects to develop implementation strategies for this technology.

The contents of this report are not to be used for advertising, publication or promotional purposes. Citation of trade names does not constitute an official endorsement or approval of the use of such commercial products. The findings of this report are not to be construed as an official Department of the Army position, unless so designated by other authorized documents.

DESTROY THIS REPORT WHEN IT IS NO LONGER NEEDED

DO NOT RETURN IT TO THE ORIGINATOR

USER EVALUATION OF REPORT

REFERENCE: USACERL Technical Report 97/87, *The Use of Direct Digital Controls in Utility Systems at Army Installations*

Please take a few minutes to answer the questions below, tear out this sheet, and return it to USACERL. As user of this report, your customer comments will provide USACERL with information essential for improving future reports.

1. Does this report satisfy a need? (Comment on purpose, related project, or other area of interest for which report will be used.)

2. How, specifically, is the report being used? (Information source, design data or procedure, management procedure, source of ideas, etc.)

3. Has the information in this report led to any quantitative savings as far as manhours/contract dollars saved, operating costs avoided, efficiencies achieved, etc.? If so, please elaborate.

4. What is your evaluation of this report in the following areas?

a. Presentation: _____

b. Completeness: _____

c. Easy to Understand: _____

d. Easy to Implement: _____

e. Adequate Reference Material: _____

f. Relates to Area of Interest: _____

g. Did the report meet your expectations? _____

h. Does the report raise unanswered questions? _____

i. General Comments. (Indicate what you think should be changed to make this report and future reports of this type more responsive to your needs, more usable, improve readability, etc.)

5. If you would like to be contacted by the personnel who prepared this report to raise specific questions or discuss the topic, please fill in the following information.

Name: _____

Telephone Number: _____

Organization Address: _____

6. Please mail the completed form to:

Department of the Army
CONSTRUCTION ENGINEERING RESEARCH LABORATORIES
ATTN: CECER-TR-I
P.O. Box 9005
Champaign, IL 61826-9005

REPORT DOCUMENTATION PAGE

Form Approved
OMB No. 0704-0188

Public reporting burden for this collection of information is estimated to average 1 hour per response, including the time for reviewing instructions, searching existing data sources, gathering and maintaining the data needed, and completing and reviewing the collection of information. Send comments regarding this burden estimate or any other aspect of this collection of information, including suggestions for reducing this burden, to Washington Headquarters Services, Directorate for Information Operations and Reports, 1215 Jefferson Davis Highway, Suite 1204, Arlington, VA 22202-4302, and to the Office of Management and Budget, Paperwork Reduction Project (0704-0188), Washington, DC 20503.

1. AGENCY USE ONLY (Leave Blank)

2. REPORT DATE
June 1997

3. REPORT TYPE AND DATES COVERED
Final

4. TITLE AND SUBTITLE
The Use of Direct Digital Controls in Utility Systems at Army Installations

5. FUNDING NUMBERS
4A162784
AT45
FE-X05

6. AUTHOR(S)
David D. Underwood and Alfonso C. Guativa

7. PERFORMING ORGANIZATION NAME(S) AND ADDRESS(ES)
U.S. Army Construction Engineering Research Laboratories (USACERL)
P.O. Box 9005
Champaign, IL 61826-9005

8. PERFORMING ORGANIZATION
REPORT NUMBER
TR 97/87

9. SPONSORING / MONITORING AGENCY NAME(S) AND ADDRESS(ES)
Headquarters, U.S. Army Corps of Engineers (HQUSACE)
ATTN: CEMP-ET
6208 Pulaski, 20 Massachusetts Ave, NW.
Washington, DC 20314-1000

10. SPONSORING / MONITORING
AGENCY REPORT NUMBER

11. SUPPLEMENTARY NOTES
Copies are available from the National Technical Information Service, 5285 Port Royal Road, Springfield, VA 22161.

12a. DISTRIBUTION / AVAILABILITY STATEMENT
Approved for public release; distribution is unlimited.

12b. DISTRIBUTION CODE

13. ABSTRACT (Maximum 200 words)
This study identified and investigated four major types of microprocessor-based control hardware to determine their possible application to Army utilities: (1) Programmable Logic Controllers (PLCs); (2) Single Loop Digital Controllers (SLDCs); (3) Commercial Direct Digital Controls; and (4) STD and VME bus-based controls. Variables such as cost, ease of use, programming requirements, and maintenance requirements were evaluated.
Commercial DDC, SLDC, and PLC were found to have features most useful to Army utilities. The study recommended further research in the form of demonstration projects to develop implementation strategies for this technology.

14. SUBJECT TERMS
Direct Digital Control (DDC)
Army facilities
energy consumption

15. NUMBER OF PAGES
56

16. PRICE CODE

17. SECURITY CLASSIFICATION
OF REPORT
Unclassified

18. SECURITY CLASSIFICATION
OF THIS PAGE
Unclassified

19. SECURITY CLASSIFICATION
OF ABSTRACT
Unclassified

20. LIMITATION OF
ABSTRACT
SAR

Foreword

This study was conducted for the Directorate of Military Programs, Headquarters, U.S. Army Corps of Engineers (HQUSACE) under Project 4A162784AT45, "Energy and Energy Conservation"; Work Unit FE-X05, "Advanced Digital Control Concepts for HVAC." The technical monitor was Joe McCarty, CEMP-ET.

The work was performed by the Engineering Division (FL-E) of the Facilities Technology Laboratory (FL), U.S. Army Construction Engineering Research Laboratories (USACERL). The USACERL principal investigator was David M. Underwood. Larry M. Windingland is Acting Chief, CECER-FL-E; and Donald F. Fournier is Acting Operations Chief, CECER-FL. The USACERL technical editor was William J. Wolfe, Technical Resources.

Dr. Michael J. O'Connor is Director of USACERL.

Contents

SF 298	1
Foreword	2
List of Figures and Tables	5
1 Introduction	7
Background	7
Objectives	8
Approach	8
Notice	8
Scope	9
Mode of Technology Transfer	9
2 Digital Control	10
Direct Digital Control and EMCS	10
Analog Input	11
Analog Output	12
Digital Input	13
Digital Output	14
New Challenges	14
Various Control Hardware Choices	14
3 Programmable Logic Controller	16
Background	16
Hardware	17
Software	21
Operation	27
Local HVAC Control and Energy Management Applications	28
Trends and the Future	28
4 Single-Loop Digital Controller	30
Background	30
Hardware	30
Software	32
Operation	32
Trends and the Future	33

5	Commercial DDC	34
	Background	34
	Hardware	35
	Software	35
	Operation	36
	Trends and the Future	37
6	STD and VME Bus Systems	41
	Background	41
	Hardware	42
	Software	42
	Operation	42
	Trends and the Future	43
7	LonWorks	44
	Background	44
	Trends and the Future	45
8	Summary and Recommendations	48
	Summary	48
	Recommendations	49
	References	51
	Distribution	

List of Figures and Tables

Figures

1	Direct digital control	10
2	Local pneumatic controls with ECMS setpoint	11
3	Digital input	13
4	Single-loop digital controller	15
5	Multiple-loop digital controller	15
6	PLC backplate	18
7	Module insertion	18
8	Detachable terminal block	18
9	Generic ladder logic program	23
10	Mode implementation ladder logic	24
11	USACERL PLC HVAC controls and energy management demonstration	28
12	Utility controls with LonTalk	46
13	LonTalk field panel	47

Tables

1	Typical analog input ratings	11
2	Resolutions for 0–100 °F sensor, transmitter	12
3	Typical digital input ratings	14

4	PLC I/O capacities per module	19
5	PLC MTBF	20
6	Point configuration for VAV AHU	21
7	BACnet functional groups	39
8	BACnet standard object types	40

1 Introduction

Background

Historically, controls for utility systems have undergone dramatic change. Heating, Ventilating, and Air-Conditioning (HVAC) systems, for example, were first controlled manually, then mechanically, then pneumatically, then with electronic analog devices, and finally by microprocessor control. While microprocessor control provides many benefits over previous methods, it also raises new questions and challenges for designers and users. While the means of control has changed, the companies that share the majority of the Army utility controls market have not yet changed. The use of more general purpose control—Direct Digital Control—hardware such as personal computers and data acquisition cards, industrial-based PC systems such as those based on the STD and VME bus,* programmable logic controllers (PLCs), and even single loop digital controllers (SLDCs) have greatly affected industrial controls and, to a lesser degree, utility controls such as those found in HVAC. SLDCs have become the standard controls requirement for Army HVAC control in new construction.

For example, the PLC, which was once used almost exclusively in the process and manufacturing industries, has recently become a much more versatile controller and consequently has acquired the interest of other control markets. Software for these alternative controls has improved dramatically in capabilities and ease of use. Many third-party software vendors have interfaced their products with these industrial control devices. Drivers that allow monitoring, programming, and supervisory control via a central PC can interface to several different vendors (one interfaces with over 150 different devices) make multiple-vendor control system a real possibility.

In the past, these industrial control hardware have offered little competition to commercial controls largely because of their relatively higher cost and more limited functionality. PLCs, for instance, began as relay replacements and had only digital input-output (I/O). The control industry has seen a great many changes in the last

* STD bus is defined by IEEE Standard 961, 1987 (R1994) (Institute of Electrical and Electronics Engineers, P.O. Box 1331, Piscataway, NJ 08855-1331); VME bus is defined by the VMEbus Trade Association, 10229 N. Scottsdale Road, Suite B, Scottsdale, AZ 85253-1437, tel. 602/951-8866.

5 years. PLCs are no longer large, expensive, strictly digital devices for use exclusively in manufacturing and batch control environments. They now come in a variety of packaging arrangements, have analog I/O, include advanced mathematical capabilities (e.g., proportional-integral-derivative [PID] function, square root calculation, multiplication, division), and have user-friendly graphical programming interfaces.

While some of the inherent problems of microprocessor control remain, their domination of the large manufacturing industry has resulted in refined capabilities so they now offer an attractive alternative in environments requiring both digital and analog I/O. Industrial and commercial controls are becoming increasingly similar. Industrial controls such as PLCs also appear to have a decided advantage in the area currently receiving a great deal of interest: multiple-vendor control systems. This review of control system hardware and software alternatives was undertaken to evaluate direct digital controls for their potential applicability to utility systems on U.S. Army installations.

Objectives

The objectives of this research were to identify and evaluate the various microprocessor-based control (direct digital control) hardware and software available for use as utility controls at U.S. Army installations.

Approach

1. Literature searches on various control systems was performed.
2. Manufacturers of various control systems were contacted via phone, trade shows, and mail for information on their system.
3. Various hardware and software was purchased and evaluated.
4. Results of the evaluation were compiled and conclusions were developed.

Notice

This study reviewed products manufactured and/or marketed by a number of firms. Mention of companies or products listed below does not constitute an endorsement of products or manufacturer, and use of information contained in this report for advertising without obtaining clearance according to existing contractual agreements is prohibited.

Allen Bradley: 1201 South Second Street Milwaukee, WI 53204 414/382-2000	American Automatrix: One Technology Drive Export, PA 15632 412/733-2000	Andover Controls: 300 Brickstone Square Andover, MA 01810 617/470-0555
Barber Coleman: Now owned by Siebe	Cornell University: Ithaca, NY 14853 607/255-4824	GESPAC: 50 W. Hoover Mesa, AZ 85210 602/962-5559
Honeywell: 621 R. 83 Bensenville, IL 60106 708/860-3869	ISA: 67 Alexander Drive PO Box 12277 Triangle Research Park, NC 27709 919/549-8288	Johnson Controls: 2188 Welsch Industrial Court St. Louis, MO 63146-4291 (314) 569-1570
Landis and Gyr Powers: 1000 Deerfield Parkway Buffalo Grove, IL 60089 708/215-1050	Modicon: AEG Schneider Automation, In. One High Street North Andover, MA 01845 508/794-0800	NIST: Gaithersburg, MD 20899 301/975-5873
Public Works Canada Sir Charles Tupper Building Riverside Drive Ottawa, Ontario K1A OM2 613/736-2257	Robertshaw Controls: Now owned by Siebe	Siemens 1600 Route 22 Union, NJ 07083 908/687-7672
Staefa Control Systems: 8515 Miralani Dr. San Diego, CA 92126 619/530-1000	Trane: 3600-T Pammel Creek Rd. LaCrosse, WI 546001 608/787-2000	Transys: 5010 East Shea Blvd. Suite C-226 Scottsdale, AZ 85254 602/483-7924
Universal Software: No longer in business		

Scope

Hardware price estimates quoted in this report reflect actual purchases or manufacturer estimates made during this study.

Mode of Technology Transfer

It is anticipated that the information gained in this study will be incorporated into future work to incorporate DDC controls into Army utility systems, as DDC technology becomes available in a nonproprietary, cost-effective manner.

2 Digital Control

Direct Digital Control and EMCS

A digital device is one that operates on binary (two) values. "Digital control" refers to either supervisory or direct control of one or more devices through a controller that is based on a digital device (such as a microprocessor) by an Analog to Digital (A/D) converter. While the resolution of A/D converters is not of great concern in HVAC applications, a discussion of it is pertinent for understanding specifications. Note that resolutions to hundredths or tenths of degrees are usually not meaningful in HVAC applications. Direct Digital Control (DDC) is the direct control of a device by a digital controller. In Figure 1, for example, the signal that modulates the valve comes directly from the digital controller. This differs from an Energy Monitoring and Control System (EMCS) (Figure 2), in which the digital controller monitors a temperature, but its single output varies the setpoint of the pneumatic controller. The signal modulating the valve comes from the pneumatic controller. Two major differences distinguish EMCS from DDC systems:

1. In an EMCS system, the local loop is controlled by a device that is separate and independent of the EMCS system. The most typical form of the local controls is pneumatic, but local controls could also be electronic or mechanical.

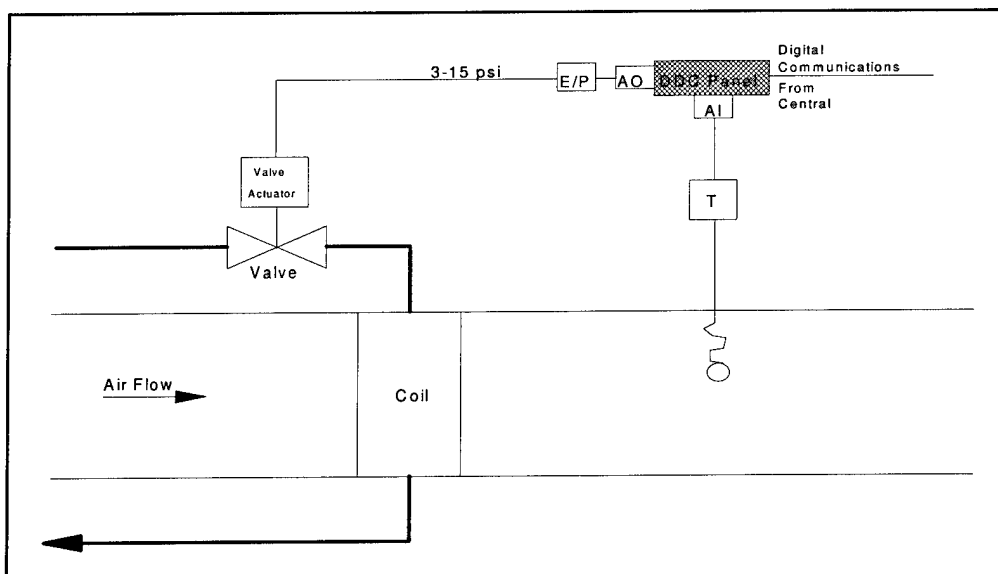

Figure 1. Direct digital control.

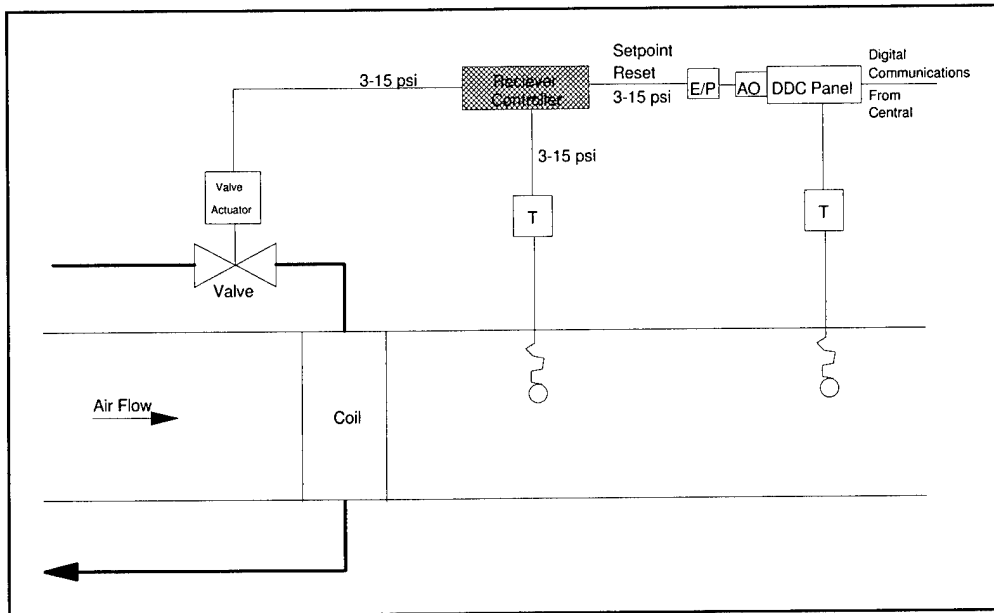

Figure 2. Local pneumatic controls with ECMS setpoint.

2. EMCS systems require duplicate sensors.

When EMCS systems were first installed, the price of computing hardware was much higher than it is today. An economical EMCS system was generally comprised of one large computer that performed all of the computing. For the sake of reliability, this computer performed only supervisory control. The local loop was always controlled directly by local controls. As hardware costs decreased, it became economically feasible to distribute computing hardware to the field, resulting in systems like the one shown in Figure 2. Digital controls have rapidly become "intelligent" tools. The typical distributed DDC system today consists of intelligent field panels with a personal computer acting as the central console user interface to monitor and collect data. Future technologies are likely to continue the trend by even further distributing "intelligent" hardware all the way down to the sensor level. This has already happened in many process industries.

Analog Input

Variables such as temperature, pressure, humidity, and flow are monitored by DDC controllers via an analog input (AI) module. An AI signal usually arrives at the DDC controller as a continuously variable voltage or current. Table 1 shows typical input ranges for AI modules.

Table 1. Typical analog input ratings.

4-20 mA
0 to +1 Volts DC
0 to +5 Volts DC
0 to +10 Volts DC
1 to +5 Volts DC
-5 to +5 Volts DC
-10 to +10 Volts DC

Temperatures, for instance, are typically measured by monitoring a voltage or current that varies with the resistive property change of the sensor. The voltage or current signal is then transduced by an Analog to Digital (A/D) converter. The A/D converts the voltage or current level into an input signal the computer can understand, normally a digital word that can be characterized by its size. Typical sizes are 8, 12, or 16 bits. The 8-bit digital word has 256 (2^8) discrete increments. This size, referred to as the resolution, affects the control system's accuracy. For example, a sensor rated from zero to 100 °F might have a transducer/transmitter that outputs 4 to 20ma, and that is read by a circuit with an A/D converter designed for this input range. Temperature measurements in this example are transduced into 256 discrete values, or 0.39 °F increments. This means that a microprocessor-based controller would have to interpret the temperature between the 0.39 °F increment to the nearest rounded off value. A temperature of 0.10 °F, for instance, is interpreted as 0 °F:

$$\text{Resolution} = 100 \text{ °F} / 256 = 0.39 \text{ °F}$$

[Eq 1]

Increasing the bit size of the A/D converter increases the number of discrete values that represent the measured temperature. A 12-bit converter, for example, has 4096 (2^{12}) discrete values. A 16-bit converter has a resolution of 65536 (2^{16}) incremental steps. Table 2 lists the various resolutions for a 0 to 100 °F sensor, transmitter.

Table 2. Resolutions for 0–100 °F sensor, transmitter.

D/A Bits	Resolution
8	0.391 °F
12	0.024 °F
16	0.001 °F

Analog Output

The AO signal is generated by reversing the process for an AI. It begins as a digital word, or value, computed by the microprocessor, which is sent to a Digital to Analog (D/A) converter. At the D/A converter, the digital value is converted to a voltage or current; this signal is eventually sent to an actuator device. Pneumatic actuators are by far the most common in HVAC, so in this case, the voltage or current signal is converted to a pneumatic signal via either an E/P (voltage to pneumatic) or I/P converter (current to pneumatic) transducer.

Digital Input

A digital input (DI) (i.e., Binary Input) signal usually originates at a switch or relay of some kind. This signal has only two defined states, either on or off, open or closed. Since a bit also has two values, the controller needs only one bit to detect the state of a DI. This means that a DI status can be evaluated by the microprocessor by evaluating single bits. Analog input, on the other hand, requires evaluation of several bits, the number of which depends on the resolution. Digital inputs are rated in terms of voltage ranges, current ranges, and type of current (alternating or direct current).

The two states are specified in terms of minimum and maximum values. Typically, one state is defined as off and the other as on. The off state is defined by some maximum voltage at which the input is no longer considered to be off. The on state is defined by a minimum voltage below which the input is no longer considered to be on. Voltages in between these minimum and maximum values have no defined state. In Figure 3, the off state is defined as an input value between zero and 0.4V and the on state is defined as 4.6 to 5.0V. Any other value is undefined. While the off state is usually defined as a value near zero volts as in our example, the on state varies according to the field device being monitored. Table 3 lists typical values for the on state (Bryan and Bryan 1988).

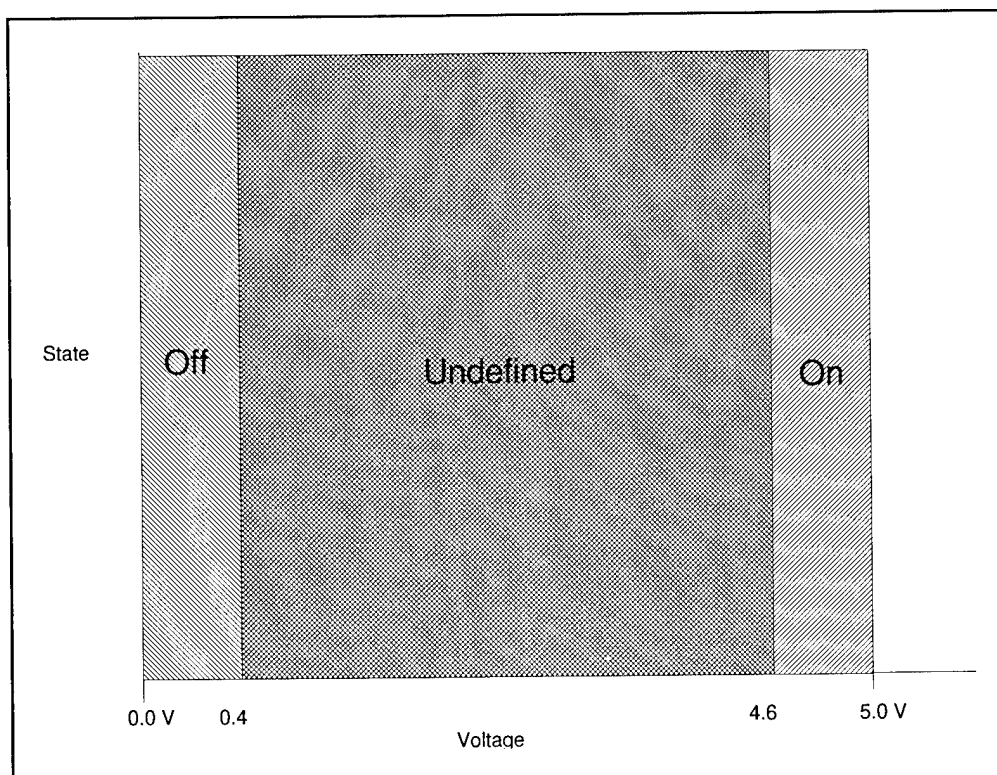

Figure 3. Digital input.

Most of these ranges are self explanatory, with the possible exception of "TTL" and "Non-Voltage." TTL (Transistor-Transistor Logic) Level inputs have input circuitry similar to the AC/DC inputs, but the input delay time caused by filtering is generally much shorter, making them suitable for applications requiring fast processing. The field device connected to the TTL DI module must of course be capable of generating a TTL (5VDC) signal. A non-voltage input is one in which the field device is not required to be powered by an external power source. Typical non-voltage field devices include dry contacts from standard relays, some proximity or photoelectric switches, and solid state relay or instrumentation devices that provide an open collector output.

Table 3. Typical digital input ratings.

24 Volts AC/DC
48 Volts AC/DC
120 Volts AC/DC
230 Volts AC/DC
TTL Level
Non-Voltage
Isolated Input
5-50 Volts DC

Digital Output

A digital output (DO) (i.e., a Binary Output), much like the DI, also has two possible states and is represented in the controller by a single bit. A DO is used to turn equipment on and off, such as motors, pilot lights, and alarms. Usually intermediate relays are required between the DO of the controller and the intended device due to voltage and current limitations of the digital controller DO. Output ratings for DO are similar to those for DI (Table 3).

New Challenges

In the past, the EMCS operated completely independent of the local controls with the exception of setpoint reset, so it was not a problem if the local controls in one building were made by a different manufacturer than those in another building. If, however, it is desired to interconnect direct digitally controlled loops into a distributed system to perform energy management functions, central monitoring, etc., then suddenly several problems arise. Proprietary communications performing global functions such as demand limiting will become difficult through the EMCS.

Various Control Hardware Choices

Several types of controls are available today, each with specialized features that make it unique. Controls can be broadly categorized into two types: commercial and industrial. Commercial systems tend to be more "general purpose" in nature,

and industrial controls tend to be more specialized. Industrial controls also tend to be designed to function in relatively harsh environments. Another useful distinction is between single- and multi-loop controllers. The difference between single- and multi-loop DDCs is the way that the hardware is packaged. Single-loop refers to hardware packaged so each loop is controlled by a separate piece of hardware (Figure 4). Multi-loop refers to hardware packaged so multiple loops are controlled by a single piece of hardware (Figure 5).

While this study attempted to review controls with a general application to all utilities, HVAC systems were emphasized because HVAC systems are common, and because HVAC systems have traditionally been controlled with digitally based hardware designed specifically for that segment of the control industry. In fact, the term DDC has been incorrectly used in the HVAC industry to refer exclusively to this hardware, which is referred to in this report as "commercial DDC."

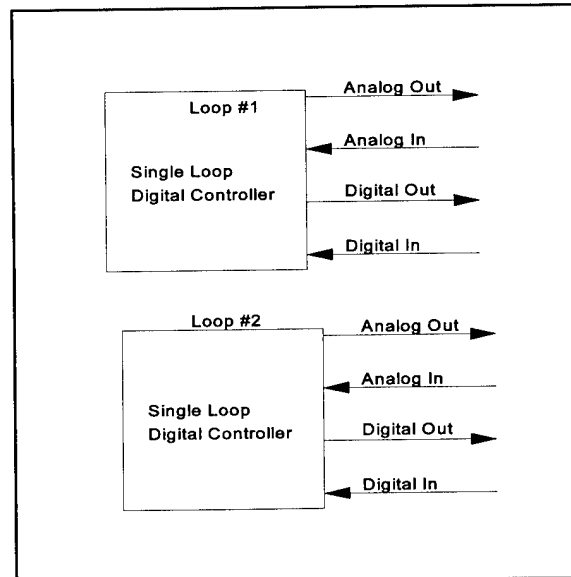

Figure 4. Single-loop digital controller.

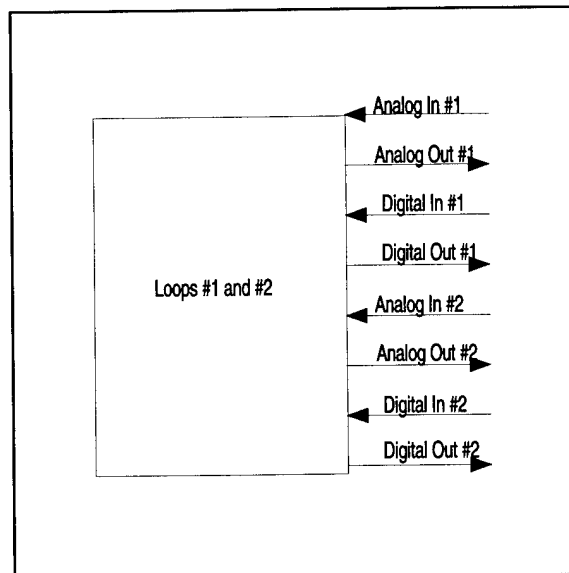

Figure 5. Multiple-loop digital controller.

3 Programmable Logic Controller

Background

Modicon introduced the first programmable logic controller (PLC) in 1969 as a replacement for the massive, hard-wired relay panels used in manufacturing plants to control machine tools and assembly lines. The novel feature of this new device was that it was programmable. The PLC not only saved factory floor space by replacing the relay-based systems, but it could also be reprogrammed for different applications. This was quite an improvement over hard-wired systems, which often had to be scrapped for even the slightest change to the manufacturing scheme because it was more expensive to redesign and rewire than to start from scratch. PLCs are famous for their ability to withstand severe environments and for their long-term reliability. The additional features of modularity, expendability, diagnostics, and reliability in an industrial environment also led to the PLCs success.

Since 1969, PLCs have evolved from strictly logic-oriented devices into extremely sophisticated microprocessor-based devices with increased capabilities. They have recently become available in a variety of packages with the necessary capabilities such as analog I/O to make them an economical alternative to "traditional DDC." PLCs continue to enjoy a reputation as a reliable source for manufacturing and process control, and their use can be expected to expand into other industries such as HVAC. PLCs are versatile devices that deserve consideration as the solution to many control requirements, not just relay replacements. One example of this is their use in many manufacturing facilities as the HVAC controls (Cole and Holness 1989). This seems to be the norm in facilities that use PLCs for processes such as manufacturing. There is at least one known case where a "commercial DDC" vendor subcontracted to an architectural-engineering firm to install PLCs for the HVAC controls in lieu of the controls manufactured by the contractor.*

Despite the versatility of today's PLCs, many controls professionals hesitate to apply PLCs to new applications such as HVAC controls. In the past, legitimate reasons prevented the use of PLC technology for facility control processes. Some of these included a lack of knowledge of these systems by people within the facility

* Phone conversation with James Frakes, Frakes Engineering, Indianapolis, IN 46250 (June 1992).

controls industry, the requirement for programming, a lack of capability of the technology, and the high purchase cost. Many of these characteristics have changed significantly in recent years. PLCs have been standardized. Originally, these systems were characterized as "relay replacers" because their initial function was to eliminate the need for hard-wired control relay panels. They proved very useful in industry for their ability to implement quick and easy changes in system control logic via software changes, thereby eliminating the need for making hard-wire changes in physical control panels. The maturing technology gained the ability to perform PID control, communicate from peer-to-peer, and communicate with host computers over common networks topologies. Many PLCs can now be programmed via a personal computer (PC) in common languages, e.g., BASIC, C, etc., in addition to graphical methods.

Hardware

A PLC control system is typically built from a backplane and several modules including a CPU, AI, AO, DI, DO, and, in some cases, a separate power supply and memory modules. Figure 6 shows a typical backplane that mounts on a standard DIN rail. Modules insert into this backplate (Figure 7), which contains the media (addressing and data busses) for communications between the various modules. Some vendors offer backplanes with the power supply and or CPU integrated into one assembly, but this is not extremely popular since it decreases serviceability. Once the modules are in place, wire terminations from I/O can be made at the detachable screw terminals (Figure 8). Their modular approach for assembling a control system to meet the requirements of the application at hand is one of their great assets. The availability of a wide range of I/O, CPU, and specialty modules contributes to the PLC's ease of maintenance, reusability, and expendability. Table 4 shows the wide variety of I/O modules available for several typical PLCs.

These product lines would fit well in HVAC applications because of their ability to provide low I/O counts at reasonable costs while maintaining functional requirements such as built-in PID algorithms. Most vendors also produce fixed I/O PLCs, which are similar to the commercial DDC hardware typically referred to as "Application Specific Controllers" (ASC). These usually provide low I/O point counts, and some contain no analog I/O (i.e., they contain digital I/O only). A typical AI module can usually be configured for either a voltage or current input. A large number of ranges are available; zero to 10V and 4 to 20mA are typical ranges. Modules with a wide range of the number of inputs are available, with two to eight inputs per module being typical of smaller PLCs that would likely be used for utility

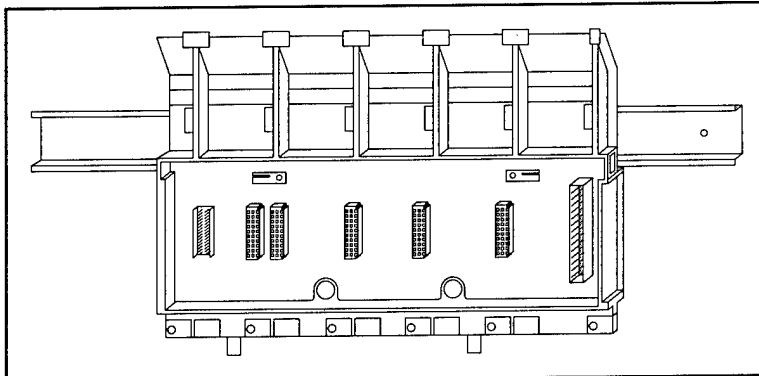

Figure 6. PLC backplate.

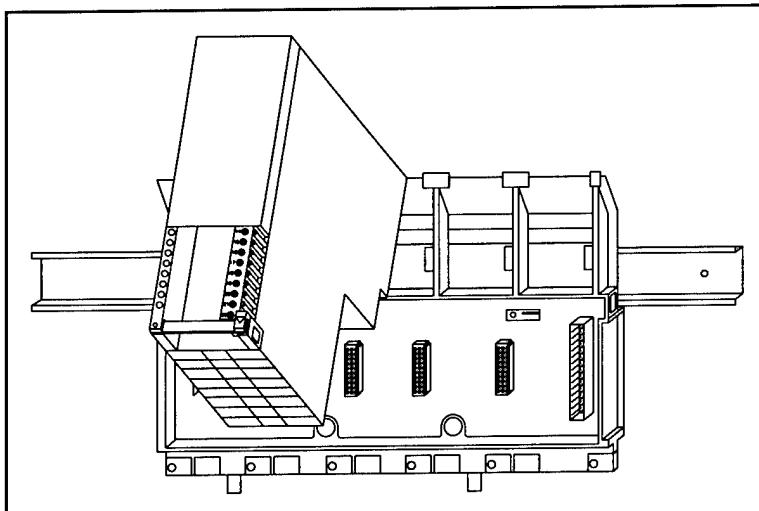

Figure 7. Module insertion.

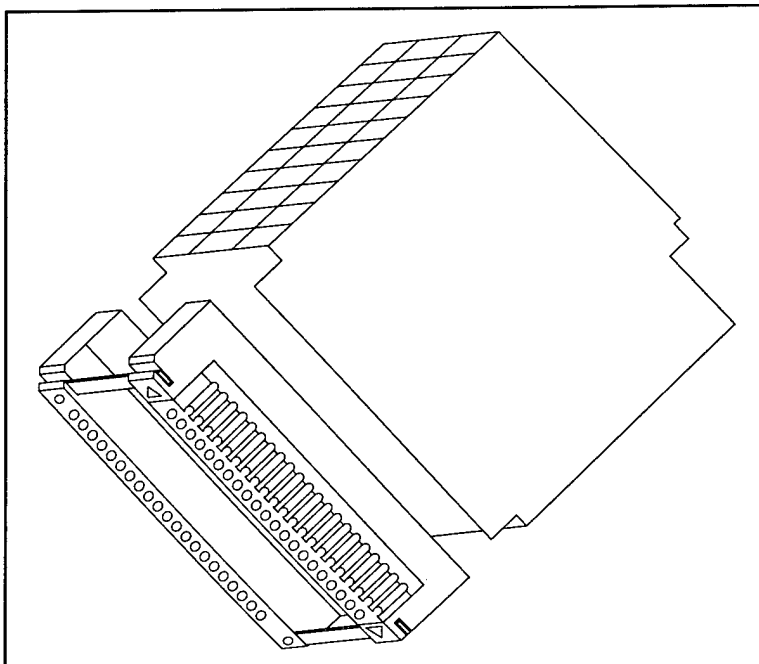

Figure 8. Detachable terminal block.

Table 4. PLC I/O capacities per module.

PLC Manufacturer	Digital Input	Digital Output	Analog Input	Analog Output
GE 90-30 Series	16	16, 12, 8, 5	4	2
GE 90-70 Series	32, 16, 12	32, 16, 12, 8	8, 4	4, 2
Allen Bradley SLC-500 Series	32, 16, 8, 4	32, 16, 12, 8, 4	4, 2	4, 2
Siemens/TI 405 Series	16, 8, 4	16, 12, 8, 4	8, 4	8, 4
Modicon 984-120 Compact PLC	16, 8	16, 8, 4	4	8, 2
B&R Industrial M264 Series	24, 16, 8	24, 16, 12, 8	16, 8, 4	8, 4

controls. If more inputs are required than available in a single card, multiple modules are added to the rack.

The analog signal originates at the sensing element, after which it comes into the module and is fed into an A/D converter. The corresponding digital word of this signal is used by the microprocessor in calculating the output control signals. As previously discussed, the description of the number of bits used and resolution also applies to the AI module of the PLC.

AO modules are very similar to AI modules, but typically are available with lower point counts because of the tendency to have more AI than AO. Combination modules with, for example, four AI and two AO are popular because of this. Again, for reasons previously discussed, AO signals for PLCs can typically be configured for either zero to 10V, 4 to 20mA, or zero to 20mA.

CPU modules differ mainly in processor speed, bus capability (number of data and address bits), and amount of memory. Both analog and digital I/O modules can then be added to meet the application requirements. Because the CPU module used determines the nonnetworked I/O capacity, a large variety of modules is typically available. For example, the minimal configuration of the PLC that was used to build a panel to control a VAV air handler with both analog and digital I/O would consist of one CPU module (Modicon 984-A120) and one each of the I/O types for a total of five modules resulting in eight digital inputs, four digital outputs, four analog inputs, and two analog outputs. This hardware lists at \$1,500.

I/O capacity in PLCs, which is a function of the CPU module, is usually specified in terms of bits. An area of memory accessible by the CPU called the Data Table determines I/O capacity. The Data Table is sometimes divided into two separate tables, one for inputs and the other for outputs, called the Input Table and Output Table respectively. Digital I/O takes one bit per point and analog I/O takes a number of bits equal to its resolution. An AI module with four channels and 12-bit

resolution would require 48 bits of Data Table memory. The Modicon 984-A120 CPU module, for example, has a 512-bit Data Table. The resolution of its analog I/O is 16 bits. This particular CPU module is also constrained to a maximum of 256 digital I/O. One possible configuration is therefore 24 analog I/O (taking up 384 bits) and 128 digital I/O (taking up 128 bits) for a total of 512 bits.

To further expand the total networked point count, 247 of these CPU modules can be networked together via the built-in master-slave communications port. If this does not meet the application requirements, other CPU modules are available in the same product line (18 total) which have different capacities and speeds, all of which are both hardware and software compatible. This is evidenced by the following statement: "The 984 instruction set (the functional capabilities of the controller, part of the system firmware stored in executive PROM) comprises logic functions common to other 984s. This means that user logic created on a mid-range or high-performance unit such as a 984-685 or a 984B can be relocated to a smaller controller such as a 984-145 (assuming sufficient memory in the smaller machine) and that logic created on a smaller controller is upwardly compatible to a larger unit. As your application requirements increase, it is relatively easy to upgrade your controller hardware without having to rewrite control logic" (Modicon 1991).

PLC hardware is extremely rugged and reliable, as evidenced by the data listed in Table 5, which shows the mean time between failure (MTBF) values of various PLC components for two PLC vendors. The MTBF was calculated for the components of the PLC hardware combined to function as a single unit. The VAV air handling unit as specified in the Army Corps of Engineers Technical Manual on HVAC controls (Technical Manual [TM] 5-815-3) was chosen as a typical control panel and the MTBF of a PLC panel for this configuration was calculated as specified in the Corps of Engineers "EMCS Overall Reliability Calculations" (U.S. Army Corps of Engineers Huntsville Division 1987). The I/O points required for this panel are given

Table 5. PLC MTBF.

Module	MTBF (Hours)	
	Modicon 984-A120	Siemens TI 405
CPU	400,000	1,812,000
Digital Input Module	1,029,866	568,000
Analog Input Module	811,688	2,699,000
Digital Output Module	522,008	8,512,000
Analog Output Module	237,192	979,000
Cumulative Reliability	92,296	261,651

in Table 6. The results are listed at the bottom of Table 5 as “Cumulative Reliability.” The formulas specified there are given here as Equations 2 and 3. This method considers failure of any single component to comprise failure of the entire unit.

$$R = e^{(-t/MTBF)} \tag{Eq 2}$$

where t = 1000 hr, and

$$\text{Cumulative MTBF} = - \frac{1000}{\text{Ln (Cumulative Reliability)}} \tag{Eq 3}$$

where Cumulative Reliability = R1 × R2 × R3 × R4 × R5.

Table 1 lists R1 through R5.

Software

The use of PLCs for HVAC control is fairly straightforward if one does not require energy management application software. PLCs can perform local loop control, can be networked, have available data acquisition and monitoring packages, and in general can duplicate the functions of a “commercial DDC.”

Various tools are available to program PLCs, but for the past 26 years, graphical relay ladder logic programming has been used the most. Graphical relay ladder logic programming evolved directly from the wiring diagrams used to hard-wire the relay panels that the PLC replaced. In the original relay ladder logic diagrams,

Table 6. Point configuration for VAV AHU.

Type	AI	AO	DI	DO
Total	5	3	7	1
Description	Return air temp.	Mixed air temp.	Fan filter switch	Fan on
	Outdoor air temp.	Fan speed	Fan proving switch	
	Mixed air temp.	Chilled water coil	Freeze stat	
	Supply air temp.		Supply air smoke alarm	
	Static pressure		Return air smoke alarm	
			Night stat	
			Auxiliary fan on relay	

symbols representing relay contacts and coils were drawn in horizontal lines arranged like the rungs of a ladder. If the states of the switches within a particular rung (which represented actual inputs) would allow power to flow through the rungs, the output coil (which represented an actual output) would be turned on. Programming of PLCs for logic purposes is commonly symbolized with a ladder diagram. Figures 9 and 10, for example, show a generic ladder logic diagram for a Single Building Dual Temperature Hydronic system as defined in the Army Corps of Engineers technical manual on HVAC Controls (U.S. Army Corps of Engineers Huntsville Division 1987). When this is compared to a hard-wired relay logic control system, the advantages of PLCs becomes quite apparent. Other functions, such as analog input scaling and comparison functions, are typically done in function blocks, as shown generically on lines 1 and 2. Lines 3 through 11 represent all the logic required to select the different modes of operation. Lines 12 through 14 determine the setpoint of the hot water supply. Lines 15 through 27 implement the modes of operation.

Over time, ladder programming has become more powerful. Timer and counter instructions were added. Arithmetic functions (addition, subtraction, multiplication, and division of values stored in referenced PLC memory locations) were also introduced. Data manipulation instructions, which allow data comparison (<, >, =), data conversions, and other multi-bit operations, have also become part of the ladder diagram instruction set. As the need for more and more sophisticated mathematical capabilities became apparent, "special function blocks" were added to the programming language. Function blocks are software objects representing specialized control functions. A user can apply the same control functionality repeatedly by encapsulating it in function block form, storing the function block in a library, and then installing copies of the function block as many times as necessary in control programs. These special function blocks allow the user to program the PLC for various advanced applications, such as the PID loop control.

Differences between software programs available from PLC vendors can vary from minimal menuing differences to completely different methods of programming and analysis. Consequently, the "learning curve" can also vary. For instance, a graduate student who had previously programmed using only one PLC interface was able to successfully program, using their software, a second vendor's PLC to perform as a VAV panel, in 20 hr. This procedure included installation of the software, learning the new interface, programming, and debugging.

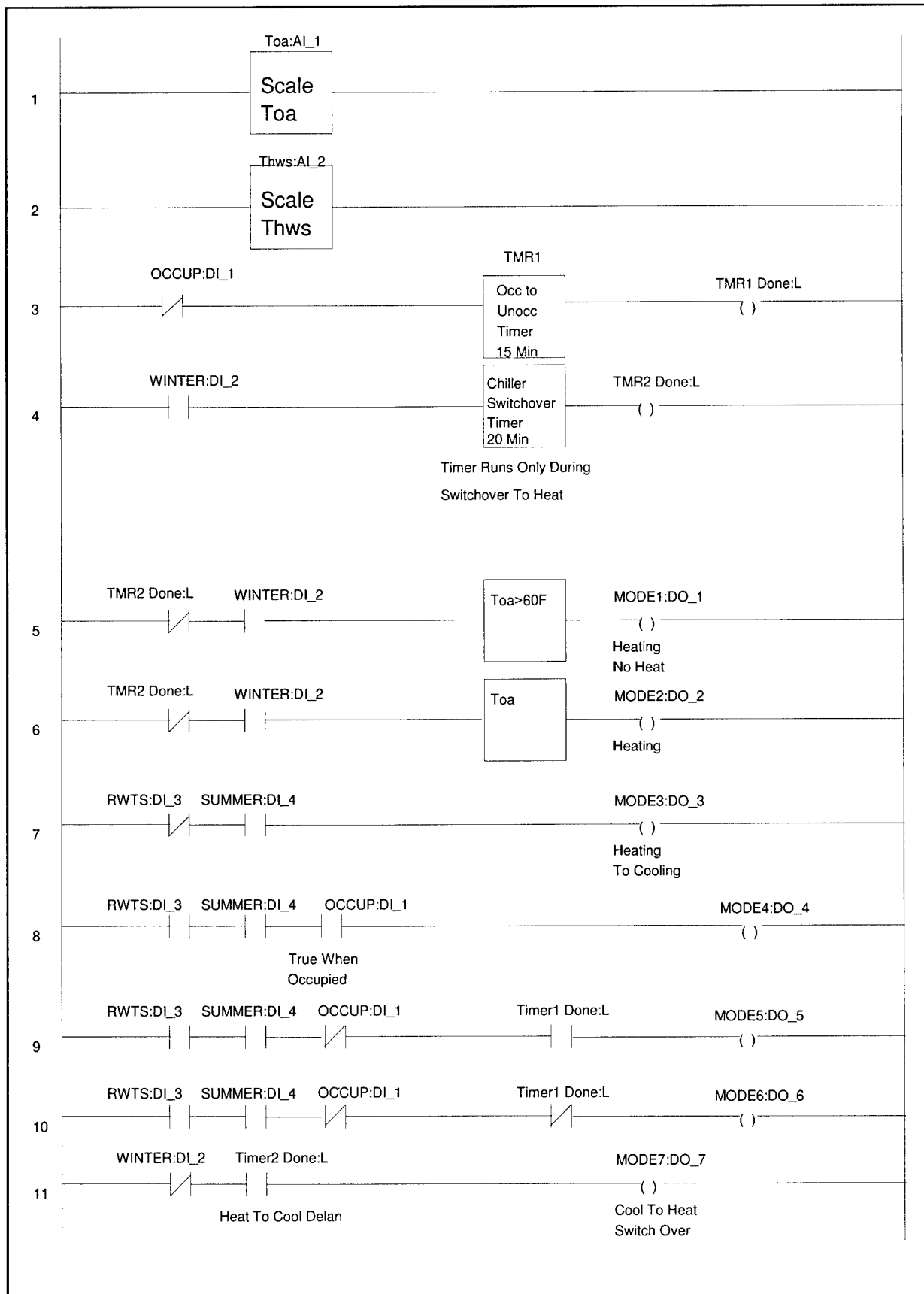

Figure 9. Generic ladder logic program.

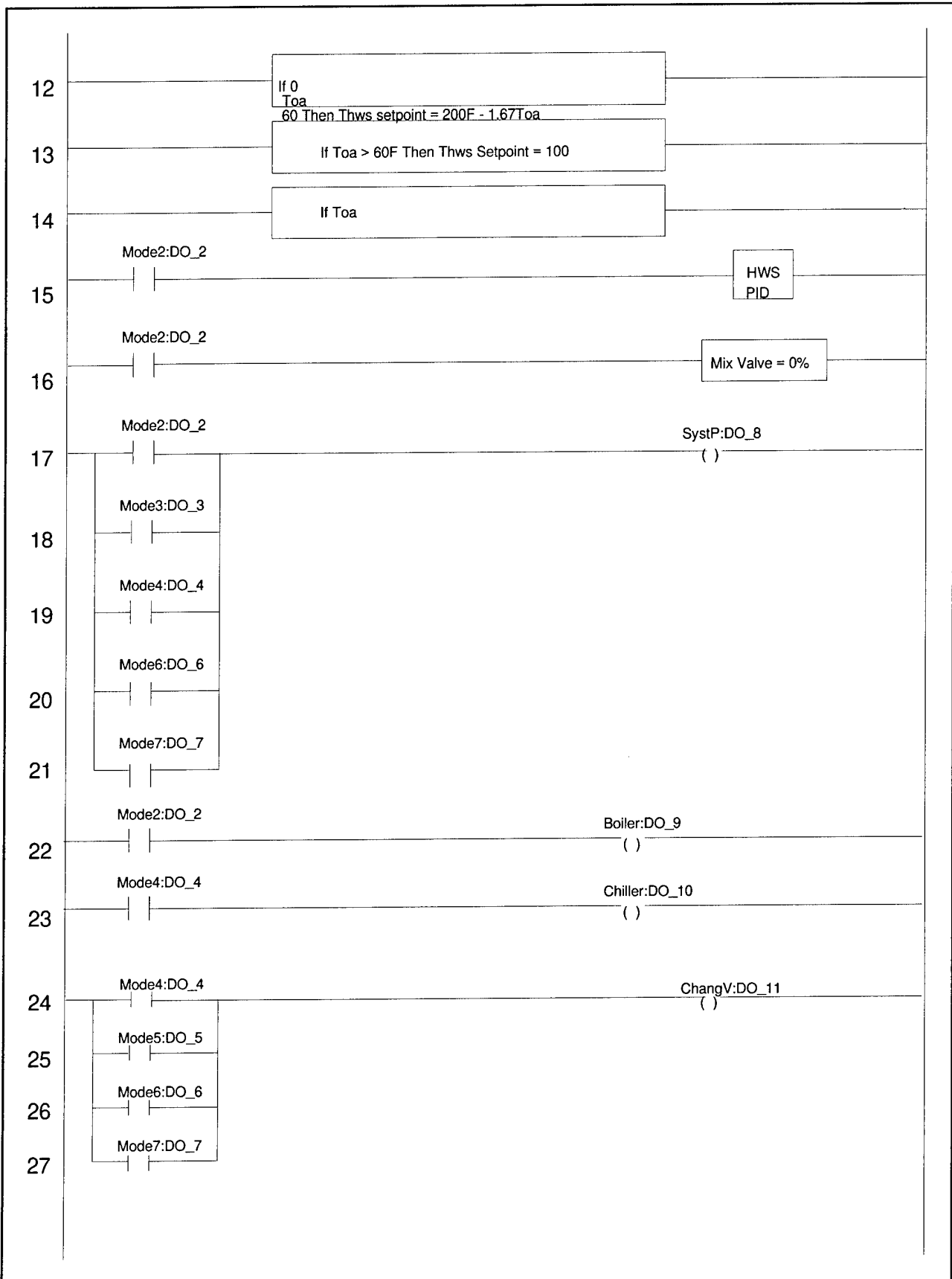

Figure 10. Mode implementation ladder logic.

This was possible because the concept of ladder logic programming is universal. Some interfaces from the vendors, however, require significant learning curves. The same student required twice the time to learn and program another PLC for the same purpose.

Although ladder logic presently remains the most widely used programming tool, other programming methods are rapidly gaining acceptance. The International Electromechanical Committee (IEC) began working on a standard PLC programming language in 1979. The current standard, IEC-1131-3, defines five standard languages for PLCs:

1. Ladder logic
2. Function block diagram
3. Sequential function chart
4. Instruction list
5. Structured text.

The first three programming languages are graphical, while the latter two are text-based. IEC-1131-3 has made programming of PLCs more uniform for programmers, system integrators, and users. The five different languages are linked into a single executable program, so that the differences of those five languages are transparent to the user. This standard has had a greater initial acceptance in Europe, but is now rapidly gaining acceptance in the United States, where the ladder logic and Sequential Function Chart (SFC) are still the primary methods used. SFC is a method for grouping ladder logic programs into blocks associated with steps within a process. Some higher level languages such as such as "C" are also gaining acceptance for tasks such as self tuning, which require sophisticated mathematical capabilities, but the primary programming tool remains in ladder logic format with a graphical interface allowing control programs to be easily configured. A group, PLCOpen, was formed to support the IEC standard. PLCOpen was founded in June 1992 and consists of researchers, PLC manufacturers, and users. This group performs the many functions required for orderly implementation of the standard such as overseeing conformance testing, accreditation, updating, etc.

While programming and limited monitoring and data acquisition software is typically included with the price of a CPU module purchase, the proliferation of third party software for PLC programming gives the user many choices that are often superior to those provided by the original manufacturer. If multiple vendor PLCs are expected to be involved, a programming package that adheres to the IEC 1131-3 PLC Programming Standard is recommended. This allows programming multiple vendor PLCs with no requirement to learn multiple programming

environments or techniques. Packages to program PLCs are available from at least 29 different sources (Hager 1991) and every day more of them are becoming compliant with IEC 1131-3.

While the majority of the third party PLC software vendors provide support for several PLC brands, some specialize in supporting single vendors, the most notable example being ICOM, which supports Allen Bradley PLCs. (Allen Bradley recently bought ICOM.) The most intriguing package to come to market recently is CADEPA from Famic. CADEPA allows the purchase of a driver for each brand of PLC to be used. Once a program is written, the driver is used to compile the program for the target PLC hardware. This allows programs to be created independently of the vendor hardware to be used. This particular package supports seven different vendors including Allen Bradley and Siemens, the leading PLC vendor in the world. Similar packages, such as Transys' ISaGRAF, adhere to IEC 1131-3. According to a survey by Control Engineering (Pollard 1995), of 11 vendors providing PLC programming software, all but one plan full support of the standard by 1996. Continued support of IEC 1131-3 is assured because the big three auto manufacturers desire it. They have created a white paper "Requirements of Open, Modular Architecture Controllers for Applications in the Automotive Industry (OMAC)," which, among other things, requires the ability to use the IEC programming standard.

Central monitoring functions such as report generation, data collection, etc. for PLCs is also most easily done with third party products. They provide operator interfaces with drivers for hundreds of devices with minimal configuration requirements for multiple vendors.

Off-the-shelf application programs to perform supervisory control with PLCs do not exist; however, most of the commonly used ones such as scheduled start/stop, demand limiting, economizer, day-night setback, and resets can be easily implemented in the ladder logic PLC program. In addition, third party tools with a graphical programming interface to create the remaining functions are plentiful. USACERL has completed a Small Business and Innovative Research (SBIR) project to develop supervisory energy management programs and expects to have a prototype system at its HVAC Test Facility. Additionally, Fort Sam Houston, San Antonio, Texas, is using PLCs for HVAC control based on the prototype at the Test Facility.

Some of the more sophisticated energy management functions such as optimum start/stop, which are infrequently used in the Army, would require capabilities more sophisticated than ladder logic and function blocks, capabilities that sequential

function charts can easily accommodate. Fortunately, many PLCs have the optional capability of programming in a high level language such as "C," which is supported in the instruction list and structured text options of IEC 1131-3.

Operation

To qualify for application to industrial processes a PLC must be able to monitor its I/O constantly when in the run condition. This process of sequentially reading the inputs, executing the program in memory, and updating the outputs is known as "scanning." The scan process generally has four phases, which are repeated continuously as individual cycles of operation when the PLC is in the run mode. While all PLCs do not scan exactly in this manner, they all perform these phases as the program is executed.

Phase 1—Input Status Scan

Each cycle begins with an input status scan. Here, sensor readings are gathered into a reserved portion of memory called the input status memory. This phase is carried out as a single step, uninterrupted by other operations, to provide a clear snapshot of the state of the process at a given instant.

Phase 2—Program Execution

The user program is executed by the microprocessor, all values in the input status memory are examined, required calculations and logic functions are performed, and the results are stored in a reserved portion of memory called the output status memory.

Phase 3—Output Status Scan

This scan sends the stored output values to actuators and field output devices.

Phase 4—Memory Word Zero

In this scan, the processor performs some housekeeping or overhead operations called memory word zero time. These overhead functions include diagnostic checks on the PLC as well as service of peripheral devices such as loader/terminals and communications interfaces. As soon as these tasks are completed, the entire cycle begins again with another input status scan.

Local HVAC Control and Energy Management Applications

Unlike Commercial DDC, PLC vendors do not typically have packaged HVAC controls or energy management applications. USACERL has worked for the past 2 years under the Small Business Innovative Research (SBIR) program to develop them. The results of this project are very encouraging. The systems integrator (Team Controls of Dallas, TX) has developed local controls for 12 of the 17 standard air handler and hydronic systems described in TM 5-815-3. Since they were developed using an IEC1131-3 compliant programming package, they are transportable to various PLC vendor platforms as previously described. They have also developed four energy management programs: Demand Limiting, Scheduled Start/Stop, Optimum Start/Stop, and Night Setback. These programs eliminate the largest obstacle to the use of PLCs in HVAC applications. As part of the SBIR project, the contractor has also set up a working demonstration of multiple vendor PLCs controlling HVAC systems. Figure 11 shows a diagram of the demonstration.

Trends and the Future

The development of an open architectures within the PLC industry is a trend that has the potential to change the industrial control industry the same way that the open architecture of the IBM personal computer changed that industry. It is presently possible, for instance, to purchase a "brand X" PLC and connect to it both

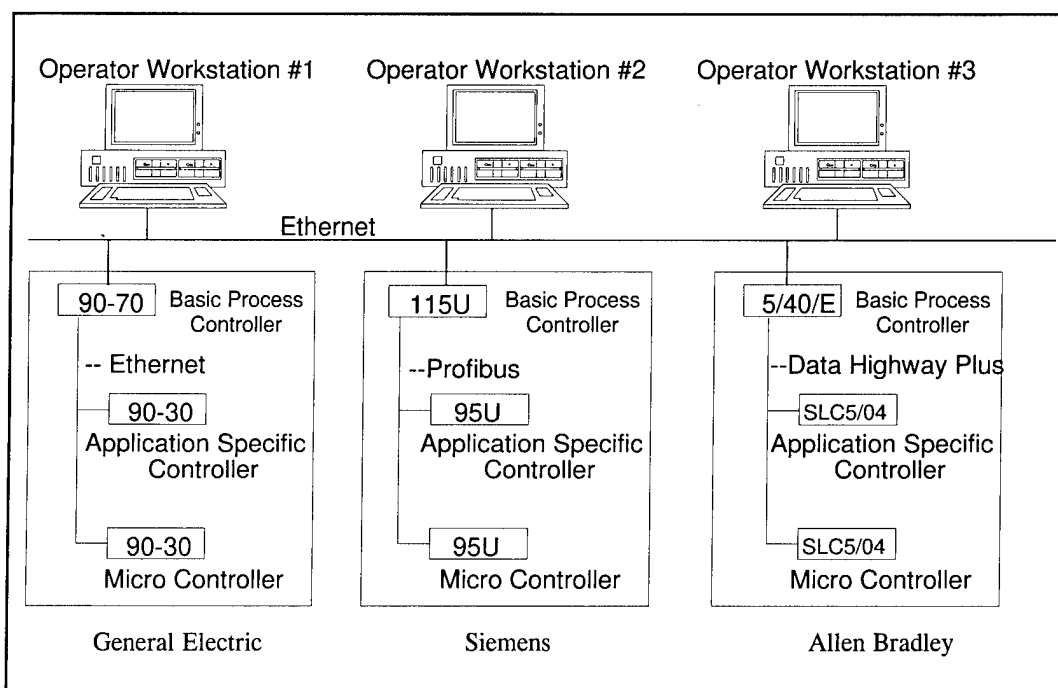

Figure 11. USACERL PLC HVAC controls and energy management demonstration

brand X and brand Y I/O. The most significant example of this is the ability that the new Modicon family of controllers has to directly access information from LonWorks devices. In the past, vendors realized the majority of profits from the sale of I/O modules. Because of that, they sold other units such as the CPU and backplane at very inexpensive rates and charged correspondingly higher rates for I/O. This gave them very strong incentives to keep the communications on the backplane proprietary so that only their brand of I/O could be used. This ability to open up PLC I/O communications is therefore seen as very significant. It focuses efforts on service and to some degree away from hardware. PLCs then are becoming a commodity to be bought from the source with the lowest cost.

Another interesting trend within the PLC industry (which parallels a similar trend within the controls industry in general) is the migration of intelligence closer to the field devices. As microprocessor technologies develop, it becomes feasible and cost effective to develop micro-PLCs that can be essentially dedicated to small applications. Other facets of this trend is the development of "smart I/O" that can communicate with PLCs over twisted pair cables, perform self-diagnostics, and protect against short circuits. One vendor (GESPEC) claims that its smart I/Os are even capable of continuing to collect data, provide supervisory control and maintain interaction between up to 8,000 I/O points, even if the twisted pair network back to a host PC fails. In addition, these modules' internal calendar clock enable them to perform daily or weekly time-based functions as well as time stamp alarm messages and generate interrupts on a host PC. The significance of this will depend on the development of a standard communications protocol.

One of the most important trends in any controls environment today is standardization of communications. The Instrument Society of America (ISA) Standards Project Committee (SP50) is currently developing a standard communications protocol for industrial controls. ISA's SP50 committee is the North American participant in a world-wide effort. Currently, the work of the InterOperable Systems Project (ISP), which merged with WorkdFIP and uses a majority of the SP50 work, is the most likely candidate to develop an accepted communications standard for industrial controls. ISP has several ongoing and planned demonstrations that use varying degrees of the proposed standard. Ambitious goals of having a finalized standard in 1996 could significantly affect the control market once they are realized.

If current trends continue, the standardization of programming PLCs using the IEC 1131-3 standard can be expected to accelerate. In the near future, programs developed to be fully portable between PLCs will decrease development costs and increase the efficiency with which problems with programs and processes can be diagnosed and resolved.

4 Single-Loop Digital Controller

Background

Single-loop digital controllers (SLDCs) are the digital counterparts of pneumatic and electronic analog controllers. The SLDC evolved out of a need by the Process Industry for better control equipment to run the process applications. At the time of its inception, the SLDC offered the process industry stable, reliable, local control in a device that was modular and virtually maintenance free. SLDCs have been used for more than a decade in manufacturing process controls in harsh industrial environments such as steel mills, refineries, paper mills, and chemical processes. The cost of SLDCs was previously too high for all but the most critical applications; when compared to multi-loop DDCs, they are still more expensive on a first cost basis. They do, however, offer benefits that multi-loop control does not. The single-loop controller itself is inherently more reliable than multi-loop and, combined with the reliability of the individual controllers, results in the most reliable control of the available choices.

Hardware

SLDCs are industrial-grade quality controllers designed for control of single loops. Typically packaged in a rectangular enclosure, SLDC usually indicates parameters on one or two digital displays that can be sequenced to view the desired parameter by a pushbutton. Options such as process variable sensor type, number of alarm outputs, control signal type, and communication capabilities can be selected at the time of purchase, allowing an interface to virtually any system. Because they were designed for single loops, they typically have only one or two of each I/O (AI, DI, AO, DO).

Perhaps the most appealing feature of SLDCs is the apparent acknowledgment by manufacturers that users desire interchangeable hardware. This is reflected in the similarities of SLDC packaging. A survey of 30 SLDC manufacturers concluded that: "The packaging of single-loop controllers, insofar as their external dimensions and panel cutouts, has become far more standardized (as compared to that of electronic analog controllers), with increased adherence to DIN and Namur standards

in particular, ensuring a basic level of compatibility, enabling replacement and enhancements to be carried out more readily" (Ingrey 1988). The DIN standard referred to is 1/4 DIN standard, which is 92mm by 92mm (3.62 in by 3.62 in). With standardized design SLDCs are interchangeable between manufacturer and application; if one of the SLDCs in an HVAC panel needs to be replaced, it can be removed and replaced with a generic component. Consequently, users can maintain equipment with a minimum of inventory.

SLDCs come with varying degrees of sophistication, and corresponding differences in cost. The more expensive models provide extensive math, logic and signal-conditioning functions, and multi-variable input. Typical prices are from \$300 to \$1,000.

To take full advantage of the interchangeable capability of SLDCs, it is necessary to specify certain features. The following are recommended as minimum requirements (Schwenk 1988):

- end-user selectable P only, PI, or PID control mode
- operator initiated-tune capability
- automatic (PID) or manual control mode
- single 4-1/2 digit display that provides display of:
 - setpoint
 - process variable
 - output
- 4 to 20mA field scalable process variable input
- 4 to 20mA output
- user-selectable maximum control signal output
- user-selectable local or remote setpoint
- two alarms, each with a mechanical relay contact output for:
 - low (or high) deviation alarm
 - absolute (process variable) alarm
- user-selectable alarm hysteresis (deadband)
- anti-reset windup (PID algorithm)
- +/- 0.3 percent accuracy
- 5-year retention of configured data.

A control panel that meets specifications of TM 5-815-3 for the VAV air handling unit described earlier can be obtained for approximately \$6,000. Control panels that meet specifications of TM 5-815-3 can be obtained for approximately \$5,800 for panels with a small number of controllers (two) to \$8,600 for panels with a larger

number of controllers (six) including drawings, data sheets, and commissioning instructions (based on pricing of panels built for Fort Hood by Johnson Controls).

Software

SLDCs typically have LCD front panel displays for viewing process conditions and configurable parameters such as PID constants. Parameters such as alarm levels, sensor range, and actuator range are typically firmware parameters selected. (A sequence of keystrokes on the front of the controller changes the parameters of a permanent, built-in program, typically stored in Electrically Erasable Programmable Read Only Memory [EEPROM].) Because of the built-in display (even though it is usually limited to between 15 and 20 characters) and the preprogrammed design, there is no requirement for a computer interface.

Self-tuning is a software feature of SLDCs that is very appealing to utility controls such as HVAC. This algorithm is built into the controller, which selects control parameters. This feature can be a great labor-saving device and routinely selects more appropriate control parameters in less time than the typical trial-and-error methods employed on systems without self-tuning. A previous USACERL study thoroughly investigated this feature (Underwood 1989). The operator need only get the process to be controlled in a steady state condition and push the self-tune button to instruct the controller to calculate new control parameters.

Operation

Ease of operation is one of the SLDCs strong selling points. Through the use of several pushbuttons (eight is typical) and LCD or LED displays, menus allow a large degree of configuration or tailoring of the controller to the process to be controlled. No programming is required; the operations are permanently stored in the controller. Although not an altogether simple procedure, configuration is fairly straightforward and can be performed quickly and easily if the user is familiar with the process and terminology used by the controller. Since all configuration is done through a menuing question-and-answer type of interface that pertains only to that loop, the user does not have to sort through large data base entries that networked systems typically have.

Trends and the Future

In the near future, SLDCs will likely begin to have features that are currently an option as a standard feature. Self tuning, adaptive control, and serial communications for the purpose of networking, for instance, will likely be a common denominator. The basic functionality of control of a single loop will remain a popular solution for a certain niche of controls. Because SLDCs are an industrial controls device, standard communications developed for PLCs will likely affect them in the same way.

5 Commercial DDC

Background

In the 1970s, control companies began producing microprocessor-based hardware for the monitoring and supervisory control of HVAC systems. Specialized software was also created to perform control functions such as setpoint reset and time scheduling. These systems were known as Energy Management and Control Systems (EMCS). The typical EMCS provided a large number of energy management and conservation programs to the operator:

- scheduled start/stop
- duty cycling
- day/night setback
- ventilation/recirculation
- reheat coil reset
- hot water boiler selection
- chiller selection
- condenser water reset
- lighting control
- optimum start/stop
- demand limiting
- economizer
- hot/cold deck reset
- steam boiler selection
- hw oa reset
- chilled water reset
- chiller demand limit
- remote boiler monitoring control.

While all of these are usually provided, only a fraction are used at a typical installation.

The high cost of computing hardware dictated that these early systems consist of a mainframe computer that performed all supervisory functions. The modulating control of devices such as water flow valves was usually done locally with pneumatic controls. The cost of computing hardware decreased slowly at first and has accelerated recently, resulting in a greater distribution of DDC hardware to the field. The more common topology these days is to have the local controls performed by DDC. The DDC standalone control panels communicate to a central point usually through a local area network.

Advances in technology and associated cost reductions in hardware have made the centralized computing configuration an outdated design. Although a few manufacturers still bid systems in the old configuration, largely due to the difficulty in

translating the software from the mainframe to centralized personal computer sized hardware. In the immediate future, nearly all control systems for HVAC will be directly controlled with standalone intelligent field panels. This does not necessarily mean that the hardware will be in the form of the typical suppliers of the past. Hardware originally intended for general purpose data acquisition or the process industries must also be considered.

Hardware

Commercial DDC, or that control hardware that is initially designed for commercial applications such as HVAC, is available with differing degrees of modularity. Application-specific or "unitary" controllers such as those used to control a chiller, heat pump, or packaged air conditioner, have a fixed limited number of I/O points, a fixed program, and few, if any user-definable database parameters. The characteristics of these devices are established at the time of manufacture, much like those of SLDCs. Another version of the application specific controller (ASC) is the "application selectable controller," which has a library of selectable programs for applications with similar numbers of I/O requirements.

In contrast to the ASC, general purpose controllers are typically more modular, are field programmable, and may have a sophisticated operator interface. These general purpose controllers are generically known as "Remote Control Units" or "RCUs," standalone smart panels that provide monitoring and control functions. RCUs maintain their own database but update a central station database either periodically or on request.

Field panels usually have battery backups to keep them operating for at least 8 hours in the event of a power loss. There are two types of panels, general purpose and the specialized. A general purpose panel can be used in almost any application if the correct number of input output channels are available. A specialized panel has been designed to control a specific piece of hardware, such as an air handler.

Software

The programming of field panels in the "Commercial DDC" hardware is very different from that of PLCs. In the past, it involved writing programs in a high level language, typically a specialized language developed specifically for that family of control hardware. This extremely inflexible aspect of traditional DDC still exists to some extent. Not only is each language very different between vendors,

but any specific language may be available from only one vendor. Some vendors now offer software that uses a graphical interface, greatly decreasing the programming expertise required to configure the field panel, but again, the software remains available from only that vendor. Other methods used include template programming and Question-and-Answer (Q&A) programming. The template method is often used to specify the functionality of simple fixed function controllers, such as SLDC. It is also used for some commercial DDC application specific controllers. The Q&A method is similar to a multiple choice exam; the user answers a series of questions with a limited number of responses.

While much work is being done on a standard communications protocol for "commercial DDC," none has begun on standardization of programming. Some application-specific DDC controllers have fixed control programs that cannot be altered, thereby completely eliminating the need for programming at that level. Such programs are limited to extremely common applications, however, because of the inflexible nature of a preprogrammed panel.

Operation

Most commercial DDC systems provide an Operator Machine Interface (OMI), which can display data in either a report or graphic format. The OMI provides remote monitoring functions across wide geographical areas. Data analysis is usually provided for at the OMI consisting of data archival, report generation, and use of adjunct third party software such as spreadsheets. The Microsoft Dynamic Data Exchange (DDE) standard is typically used to facilitate this data exchange.

Much like that of the PLC local interfaces, users have choices from a laptop personal computer, a small built-in LCD or LED display, or a specially designed handheld device.

Supervisory control programming for "traditional DDC" exists off-the-shelf. Sometimes this programming is provided as part of the control hardware, but the software typically requires modification to meet application-specific needs; such modification can be a significant expense. The package usually consists of an interface used to alter parameters that are part of a database that the packaged software accesses. For instance, the procedure for setting up start/stop times using the DDC system at USACERL was as follows. First the menu interface system is used to select the Tables function. The menu interface is then used to select Control Start/Stop. This displays a table of the points identified in the data base as start/stop points. Adding a point to this table identifies it as a start/stop point, but

does not specify the actual start/stop times. This is done by maneuvering back to the main menu and selecting the Energy Management function and then selecting the Schedules function. This accesses the start/stop times in the database, which are displayed in a table that can be edited using the arrow, =, and number keys.

Trends and the Future

The state-of-the-art Building Automation System (BAS), or DDC system, consists of personal computer-based operator consoles and standalone, intelligent field panels that provide local control and networking capabilities. As with the older EMCS systems, the point of centralized data collection commonly is known as the "Central Station." In contrast to past systems, the current and future Central Station, or OMI, serves primarily as a user interface to the system. The most typical Central Station is an IBM-compatible personal computer.

Field panels operating in a standalone mode will get smaller, more powerful, specialized, and further out into the field. They will communicate with the central operator workstation through, and to, other devices. Communication between panels and the central operator workstation will be both master-slave and peer-to-peer.

The trend of all controls, regardless of their nature, is to distribute intelligence further into the field. To facilitate this, a standard communications protocol is needed. For commercial DDC, this means BACnet™ (Building Automation Control network). BACnet is a standard communications protocol being developed by the American Society of Heating, Refrigeration, and Air Conditioning Engineers (ASHRAE), a large professional nonprofit organization of engineers, consultants, and other professionals. SPC-135 (Special Projects Committee) is the ASHRAE committee that has been developing a standard communications protocol for building automation systems since January 1987. The committee consists of members from several manufacturers, academia, and researchers. Some of the members are Andover Controls, American Auto-Matrix, Barber Coleman, Energyline, Honeywell, Landis & Gyr Powers, Robertshaw Controls, Staefa Control Systems, Trane Universal Software, Johnson Controls, NIST, Cornell University, and Public Works Canada.

The BACnet standard, an ASHRAE and ANSI standard (135-1995), states that its purpose is: "To define data communication services and protocols for computer equipment used for monitoring and control of HVAC&R and other building systems and to define, in addition, an abstract, object-oriented representation of information

communicated between such equipment, thereby facilitating the application and use of digital control technology in buildings.”

BACnet™ in its present form provides for five combinations of the first two layers (Physical and Data Link) of the ISO seven-layer communications protocol: “BACnet is based on a four-layer collapsed architecture, which corresponds to the physical, data link, network, and application layers of the OSI model. The application layer and a simple network layer are defined in the BACnet standard.

BACnet provides five options that correspond to the OSI data link and physical layers:

- Option 1 is a logical link control (LLC) protocol defined by ISO 8802-2 Type 1, combined with the ISO 8802-3 Medium Access Control (MAC) and physical layer protocol. ISO 8802-2 Type 1 provides unacknowledged connectionless service only. ISO 8802-3 is the international standard version of the well-known “Ethernet” protocol.
- Option 2 is the ISO 8802-2 Type 1 protocol combined with ARCNET (ATA/ANSI 878-1).
- Option 3 is a master-slave/token-passing (MS/TP) protocol designed specifically for building automation and control devices as part of the BACnet standard. The MS/TP protocol provides an interface to the network layer that looks like the ISO8802-2 Type 1 protocol and controls access to an IEA-485 physical layer.
- Option 4, the Point-To-Point protocol, provides mechanisms for hardwired or dial-up serial, asynchronous communication.
- Option 5 is the LonTalk protocol.

Collectively, these options provide a master-slave MAC, deterministic token-passing MAC, high speed contention MAC, dial-up access, star-and-bus topologies, and a choice of twisted pair, coax, or fiber optic media. The details of these options are described in clauses 7 through 10 (ASHRAE, p 9).

“To assist in the specification of BACnet devices, the standard includes as an annex for information purposes a “Protocol Implementation Conformance Statement.” This summarizes in a tabular format the 6 conformance classes, 13 functional groups, 18 standard object types, 35 application services, and data link layer options defined. A conformance class specifies a minimum set of services, objects, and properties, which the device must support to claim membership in a particular class. The conformance classes are numbered 1 to 6 and are hierarchial in nature. The requirements for each class include all of the requirements of all of the other

classes with a lower number. Conformance Class 1, for example, requires that the execution of the ReadProperty Application Service on a Device object type be supported. Class 2 requires that, in addition to supporting the Class 1 requirements, the device must also support the execution of the WriteProperty Application Service. Table 7 lists the 13 functional groups that define a combination of Application Services and Standard Object Types. Table 8 lists the 18 Standard Object Types that define information groups and their organization.

Devices can be expected to interoperate with respect to a given function if they are in the same conformance class and support the same functional groups. The extent to which such a system could actually be built depends on the devices that vendors choose to provide. A designer could theoretically use combinations of Standard Object Types, Application Services, and Conformance Classes to procure an interoperable system. The extent to which this will be possible depends on the actions of the controls vendors.

Initially BACnet™ will not result in “plug and play compatibility” (the capability to replace a device from one vendor with another with no loss of any functionality or reconfiguration of other devices). In fact, BACnet™ neither precludes nor ensures plug and play compatibility. Moreover, plug and play compatibility will probably *not* happen any time in the near future, if it happens at all. The first BACnet™ compatible products will very likely fall into two categories: (1) field panels, and (2) the components located “beneath” the panels in the control structure. Many companies that produce products with packaged controls such as chillers will produce equipment that communicates at some level using the BACnet™ standard. HVAC controls vendors will very likely produce field panels that communicate to the primary control network (the one connecting multiple operator workstations and primary field panels) using the BACnet™ standard. These primary field panels will very likely have a secondary communication network for other equipment such as unitary controllers, which will be proprietary. This would not necessarily mean that such devices will not be BACnet™ compatible. It depends on what parts of the standard a product must adhere to to be considered “BACnet™ compatible.” Efforts are under way to define conformance testing methods that should begin to answer such questions.

Table 7. BACnet functional groups.

Clock	Virtual Operator Interface
Hand-Held Workstation	Virtual Terminal
Personal Computer Workstation	COV Event Initiation
Event Initiation	COV Event Response
Event Response	Device Communications
Files	Time Master
Reinitialize	

Table 8. BACnet standard object types.

Analog Input	Device
Analog Output	Event Enrollment
Analog Value	File
Binary Input	Group
Binary Output	Loop
Binary Value	Multi-State Input
Calendar	Multi-State Output
Notification Class	Program
Command	Schedule

Vendors are already building prototypes and a few vendors are already marketing finished products based on the proposed standard. Products adhering to the final standard could conceivably become available within months or even weeks after the standard is approved. Designers, users, and others cannot expect, however, to begin designing, purchasing, installing, and using standard systems based on BACnet™ for some time after that. A vendor can easily claim that their products are 100 percent compatible with the standard. Without an independent evaluation of

this claim, however, one would be taking great risk to take these claims at face value. Even a product that is independently evaluated to be 100 percent BACnet™ compatible must be evaluated by the designer to determine that the functionality of the device in terms of conformance class, functional group, object types, application services, and data link option meets requirements.

6 STD and VME Bus Systems

Background

Industrial versions of the DOS-based personal computers designed specifically for control in critical applications are available in several configurations. Two standards have emerged as the leaders in this area, STD bus (ANSI/IEEE Std 961-1987) and VME bus. These standards describe various mechanical and electrical properties of the control hardware that meet the needs of the industrial environment. These standards are analogous to the various personal computer buses such as ISA and microchannel. The STD bus came into existence in 1978 via IEEE Standard 961 and is still widely used, with a market of \$90 million and over 500,000 installed systems in 1991 (Seibert 1991).

By implementing a DOS platform, this control hardware is able to take advantage of all the PC software and ease of software development environment available for the PC. STD bus has an active manufacturers group (STD MG) that monitors standards, specifications, and new technical developments to ensure orderly evolutionary growth. Rather than abandon the old standard once technology passes it up, STD bus continues to support a migration path to permit existing I/O cards to coexist on the same bus with future and past I/O cards. STD-16 bus, adopted by STD MG in September 1991, supports 32-bit 80386 and other CPUs. Memory transfer is 32-bit on card and 16-bit on the backplane. STD32, which became available in 1989 for applications that require a more powerful platform, is a proprietary bus. The original STD bus is based on an 8-bit data throughput and the new STD32 bus (introduced in 1989) allows for 8-, 16-, and 32-bit data throughput. STD32 then is backward compatible with the original STD bus. For example, a 20 MHz 80386sx CPU will work well with the same industrial card designed for the original 8085. The 16-bit STD bus architecture is quite similar in power and functionality to the PC-AT ISA bus, yet is designed specifically for the rigors of industrial applications. Another important aspect of the STD32 approach is the Inter-Processor Communications (IPC) specification. IPC allows single board computers to communicate with each other over the common bus. This is done through a bus ARBITER card, which must be in slot X of the backplane.

Hardware

The STD and VME bus standards specify the many mechanical and electrical items necessary to integrate CPU boards, I/O boards, and peripheral devices. Hardware built to these specifications are compatible with personal computer programs, but differ from personal computers in that they were intended for use in harsh environments, not the office. Besides the processor board, other boards such as memory and I/O can be plugged into the bus. These systems use the DOS operating system and can communicate over a variety of standard networks. Several versions exist of both types, most of which are backward compatible. Dozens of manufacturers produce hardware compatible with this standard. Use of systems based on this architecture would necessitate the development of application software for the Army's specific needs.

STD and VME bus systems are highly reliable. Versallogic, a STD bus manufacturer reports its average MTBF of individual boards to range between 15 and 45 years. Ziatech, a STD32 provider, provides boards with MTBF ranging from 10 to 50 years.

Software

STD and VME bus systems look exactly alike from the software perspective, because they have similar architectures and are both based on Intel microprocessors. In other words, they are compatible with software developed for the personal computer, so a wide variety of software ranging from card drivers, network operating systems, spreadsheets, and control software is available. A special Basic Input Output System (BIOS) is provided that tailors the DOS desktop oriented system to address the special requirements of embedded and control environments. This is in fact a main selling point of these systems. Distributed I/O such as Phoenix Contact's InterBus-S, GE FANuc Genius I/O, Echelon's LONWORKS, and Opto 22 are supported.

Operation

Control systems based on STD and VME standards range in application from embedded control on subway systems to controls on the Space Shuttle; a "typical" operation is difficult to describe. Such systems do not depend on "off the shelf" configurations, but are based on specifically tailored hardware/software setups that may involve higher setup and maintenance costs.

It was mentioned earlier that these systems are extremely rugged and reliable, with MTBF of 10 to 50 years. They are also very easily replaced when they do fail. Ziatech includes on the data sheet of each product a statistic called Mean Time To Replace (MTTR). For most boards this value is 5 minutes.

Trends and the Future

The STD bus has been around since 1978 and continues to enjoy widespread use, largely due to the efforts of industry groups to promote backward compatibility of new standards when taking advantage of new technology. The future will likely have a place for these controls as well. However, the first cost of these systems remains high, a circumstance that prevents them from being applied in commercial applications such as HVAC.

7 LonWorks

Background

A collection of protocols, publications, products, and agreements collectively known as LonWorks has over the last several years begun to have a significant impact on the controls industry. Because this affect is so widespread, it cannot be associated with any single type of control system. Applications of this technology include residences, commercial buildings, utilities, and manufacturing facilities to name only a few. There are currently many debates occurring over whether LonWorks-based technologies, BACnet-based technologies, or a combination of the two will prevail in the commercial DDC arena. It is not presently clear what the outcome will be. What is clear is that LonWorks technology will be a major player in several industries.

A lot of confusion exists in the controls industry about the relation of these two technologies. Since BACnet was previously described, this section concentrates on LonWorks and its relation to BACnet. Just as the key of a BACnet-based system is the BACnet protocol, the heart of a LonWorks system is the LonTalk protocol. While it is not the intent here to explain all details of either, enough of an explanation is attempted to understand the difference between the two and what part of LonTalk is allowed as part of a BACnet system. In very general terms, both protocols have in them descriptions of, among other things:

- a collection of services
- a collection of objects.

The services allow for such things reading, writing, creating, deleting, and interrogation of objects. The point to be made here is that the way this is done is different for the two different protocols. Because of this, they are not seamlessly compatible. This does not mean that a LonWorks system and a BACnet system cannot share information. It does mean that a significant amount of customization could be required. The key to these customization requirements is the organization of the objects. LonWorks devices communicate primarily with what are called

Standard Network Variable Types, or SNVTs (pronounced "snivits"). SNVTs are described in The SNVT Master List and Programmer's Guide (Echelon publication 005-0027-01). These are easily communicated among LonWorks devices by implicit messages, and require very little programming. However, since these are not the same as BACnet objects, communication of SNVTs to a BACnet device requires significant programming of the device via the use of explicit messages. The difference is significant. The following analogy should clarify the difference. An implicit message might be "Drive to the store and get me some bread." An explicit message would be much longer, such as: "Take my keys, go out the front door, close it behind you, walk to my car, open the door, get in, shut the door, put the ignition key in the ignition, start the car, put it in gear..." All of the things required in an explicit message are automatically taken care of in the implicit message. The bottom line is that while a LonWorks device could communicate with a BACnet device, it is by no means guaranteed to be an easy task.

A second way in which LonTalk and BACnet differ is the devices for which the protocol was initially targeted. LonTalk is best suited for devices at the sensor and actuator level. BACnet, on the other hand, is best suited for field panels and operator workstation types of equipment. As previously mentioned, the first public demonstration of BACnet consisted of field panels and operator workstations communicating together, not field devices. Conversely, conferences and exhibits that include LonTalk technology focus on the field devices such as sensors and actuators. This is a logical distinction that follows the architecture of most control networks that separates communications into multiple hierarchical levels. These levels include the Information Network, the Control Network, and the I/O Network. Figure 12 depicts how these three network levels are related. The function of the Information Network is to facilitate communications between operator workstations and network interface devices. The Control Network facilitates communications between network interface devices and field panels. Finally, the I/O Network makes communications between field panels and I/O devices possible. All levels are not always readily identifiable as a separate entity. The I/O network level for instance may not be a digital communications network at all, but a combination of 4 to 20ma and binary signals instead. In some cases, the Information Network and Control Network are combined.

Trends and the Future

LonWorks technology continues to evolve and enter new markets daily. The ongoing development of functional profiles, standard network variables, and Building Automation System Master Specifications should help to introduce the

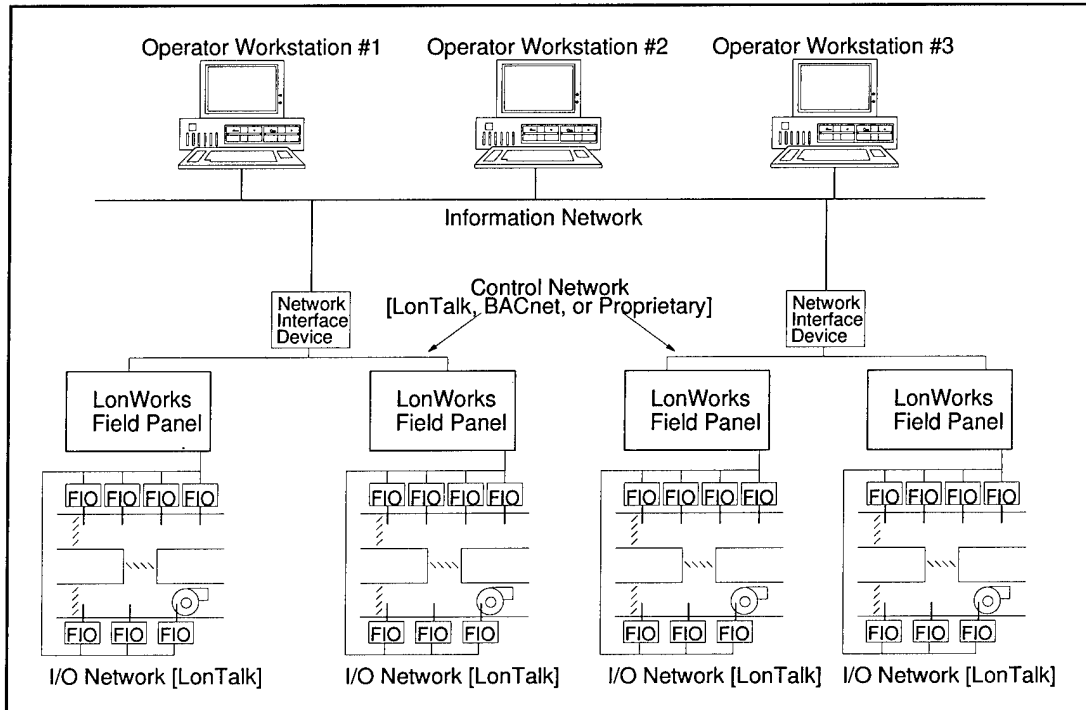

Figure 12. Utility controls with LonTalk.

technology to Utility Control System designers. The cost sensitive nature of the building controls industry and the potential cost savings of LonWorks based technology, especially the reduced wiring costs, give reason to expect LonWorks technology to be used extensively in the right markets. Figure 12 shows what the next generation HVAC control system will likely look like. BACnet, if involved, will likely function as the Information Network and possibly Control Network. Alternatively, any operator machine interface with communications drivers for the various Network Interface Device could be used, as was done with USACERL's demonstration of PLCs. LonTalk will function at the I/O network level and very likely as part of the Control Network as well. Control vendors and users with a substantial installed base have a very strong incentive to keep the Control Network proprietary, so that implementation is likely to be encountered where existing equipment is to be reused.

The field panels of the future will also look quite different due to the use of digital communications with sensors and actuators. Devices at the field level can be described in two classes. One class of device includes those that are physically close to or part of the field panel because it is desired that they be concentrated into one area. These include manual switches such as Hand Off Auto switches and pilot lights. Another class of device includes those that must be remotely located because of the physical design. These include zone temperature sensors, thermostats, actuators, and alarm devices such as smoke and low temperature levels. The result of this reality is that, despite the ability to remotely locate any sensor, actuator, or

of the physical design. These include zone temperature sensors, thermostats, actuators, and alarm devices such as smoke and low temperature levels. The result of this reality is that, despite the ability to remotely locate any sensor, actuator, or switch, the future control panel will still have hard-wired (nondigital communication) devices. The future control panel will therefore look something like that shown in Figure 13. Pneumatics will remain a desired form of actuation and will likely remain centralized at the field panel. This is certainly the case for retrofit of pneumatic controls where pneumatic lines to actuators from a central location currently exist. Pilot lights will likely be direct digital outputs of the field panel. Reset and other manually initiated field switches will also likely be located at the field panel. The most significant change will be the elimination of all home-run wiring of devices that must be remotely located. Instead, one set of wires (from two to five depending on the transceivers implemented) will be run from the field panel to one device then from that device to the next and so on. This is where the installed cost savings is achieved. Unfortunately, this increases the complexity of the system since digital communication is inherently more complex than 4 to 20ma signals. Because of this more technical nature, there are certain markets such as Army Installations in which implementation of the technology may lag.

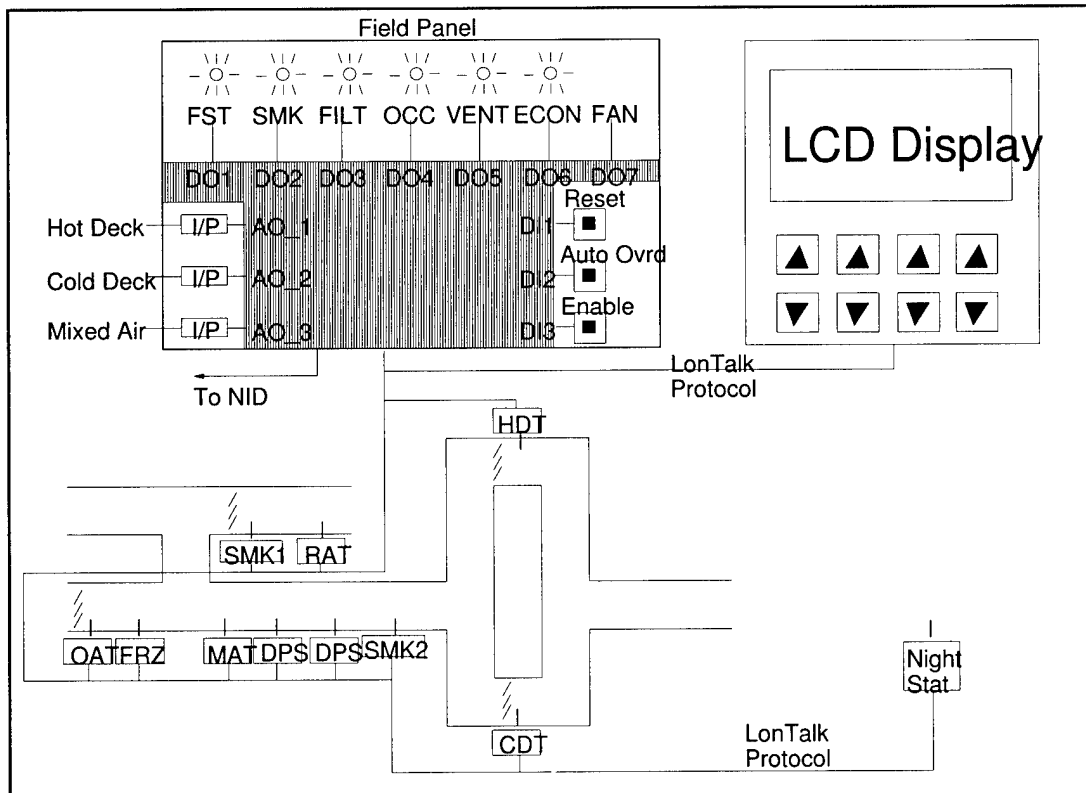

Figure 13. LonTalk field panel.

8 Summary and Recommendations

Summary

A wide variety hardware and software controls are available for use in Army utilities. However, some Army utilities, such as HVAC, have unique requirements that are not always met by "commercial DDC." Hardware such as Single Loop Digital Controllers (SLDCs), Programmable Logic Controllers (PLCs), and industrialized personal computers each have unique capabilities that may meet these requirements.

SLDC-based controls for utilities are best applied to standalone applications. Their reliability and ease of operation for maintenance personnel who may not have been to the process location for a long period of time gives them a distinct advantage in these applications. While a life-cycle cost of SLDC-based controls is competitive with alternatives, they are relatively expensive on a first cost analysis. They are also difficult and expensive to network. Implementation of energy management or other supervisory actions are also difficult to implement. While the Interoperable Systems Project is working to develop a standard communications protocol that may solve networking obstacles, factors such as the relatively high first cost will likely remain. Because of their very nature, global functions such as energy management are very difficult to perform without incurring extensive additional costs.

Like the SLDC, the reliability of PLCs is also much greater than that of commercially based controls. Their modular design and reliability provide the possibility for an economical and easily maintained control system. However, since no commercial organizations, large scale industrial support, or developed market for PLC control of HVAC systems yet exist, their use would require development of programs and training for design and operations persons. This is especially true in the Army environment where routine maintenance may fall behind schedule. Their capability to be networked not only within product families, but also with other vendors using third party integration software and de facto communication standards, is also a huge attribute. Standardization of PLC programming methods via IEC1131-3 is unique and many years ahead of any other control hardware. A Small Business and Innovative Research (SBIR) project to develop and commercialize Energy Management programs for PLCs using this standard has the

potential to standardize programs within control hardware. Software for report generation, alarm reporting, and other central operator workstation functions is readily available for industrial controls and in many aspects is far superior to that of commercial controls.

The industrial-based personal computer platforms of the STD and VME bus systems are arguably the most open systems of all. They are also one of the more expensive alternatives better suited for high performance requirements than for commercial controls. Off-the-shelf application software such as energy management does not yet exist.

Commercial DDC is currently the most widely used type of controls in utility systems at Army installations. The off-the-shelf application programs for energy management are an asset that other alternatives cannot yet offer, although this is expected to change soon. Because commercial DDC was developed specifically for utility controls (HVAC in particular), those vendors routinely have on staff personnel that understand the process to be controlled slightly better than other industries. BACnet has the potential to significantly affect the commercial controls industry. While it is expected that it will be many years before that potential impact is realized to its full potential, it is off to a good start. Eleven vendors demonstrated BACnet compliant interoperable products at the primary network interface and operator workstation levels (conformance classes 3 and 6) at the February 1996 ASHRAE winter meeting.

Recommendations

Because the controls industry is changing so rapidly, it is tempting to recommend a "wait and see" approach. Unfortunately one never knows how long the wait will be. Eight years ago it was easy to say that the Army should wait until the BACnet standard is developed and widely implemented by industry. Yet even today nobody knows how much longer this wait will be. The single-loop panels were adopted as an interim measure to fill in the gap between then and the still awaited adoption of BACnet or its equivalent. Of the other hardware investigated, PLCs are the most applicable for Army utilities. They are cost effective, reliable, easily maintained and operated, have an adopted programming standard, and are at least as close to a standard communications protocol as commercial DDC.

However PLCs, like all controls, have their drawbacks. It is anticipated that an industry will eventually adopt standard, non-proprietary communications protocol such as BACnet, which will result in an increase in the use of DDC. While a

corresponding decrease in the use of commercial SLDC is also anticipated, certain applications will continue to be uniquely suited to SLDC, and will likely continue to use those controls.

References

- ASHRAE, *BACnet™—A Data Communication Protocol for Building Automation and Control Networks*, Second Public Review Draft (American Society of Heating, Refrigeration, and Air Conditioning Engineers [ASHRAE], March 1994).
- Bryan, L.A., and E.A. Bryan, *Programmable Controllers Theory and Implementation* (Industrial Text, 1988).
- Cole, J.P., and G.V.R. Holness, *Use Of Programmable Controllers for HVAC Control and Facilities Monitoring Systems*, ASHRAE Transactions Part 1 (ASHRAE, 1989), pp 492-497.
- Hager, Robert, "The Next Step In PLC Support Software," *Control Engineering* (February 1991), pp 39-41.
- IEC1131-3, *Programmable Controllers—Part 3: Programming Languages* (International Electrical Commission, Geneva, Switzerland, 1993).
- Ingrey, A., "Single Loop Controllers," *IEEE Computers and Instrumentation* (January 1988), pp 29-32.
- Modicon, *Modicon 984 Programmable Controller Systems Manual*, ch. 1 (Modicon, 1991), p 3.
- Pollard, Jeremy, "The Future of PLC Programming," *Control Engineering* (February 1995), pp 83-88.
- Schwenk David, "Single-Loop Digital Controllers In HVAC," *ASHRAE Transactions*, vol 94, pt 2 (1988), pp 1985-1994.
- Seibert, Iris, "Longevity of STD Bus Continues," *Control Engineering* (December 1991), pp 91-93.
- Technical Manual [TM] 5-815-3, *Heating Ventilating And Air Conditioning (HVAC) Control Systems* (Headquarters, Department of the Army [HQDA], Washington, DC, July 1991).

- U.S. Army Corps of Engineers Huntsville Division and Kling-Lindquist Partnership Inc., *EMCS Overall Reliability Calculations*, HNDSP-87-204-ED-ME (U.S. Army Corps of Engineers, Huntsville Division, Huntsville, AL, June 1987).
- U.S. Army Corps of Engineers Huntsville Division and Kling-Lindquist Partnership Inc., *State Of The Art Report For Utility Control Systems (UCS)*, CEHND SP-91-250-ED-ME (U.S. Army Corps of Engineers, Huntsville Division, Huntsville, AL, October 1991).
- Underwood, David M., "Response of Self-Tuning Single-Loop Digital Controllers to a Computer-Simulated Heating Coil," *ASHRAE Transactions*, vol 95, pt 2 (1989).

USACERL DISTRIBUTION

Chief of Engineers ATTN: CEHEC-IM-LH (2) ATTN: CEHEC-IM-LP (2) ATTN: CECG ATTN: CECC-P ATTN: CECC-R ATTN: CECW ATTN: CECW-O ATTN: CECW-P ATTN: CECW-PR ATTN: CEMP ATTN: CEMP-E ATTN: CEMP-C ATTN: CEMP-M ATTN: CEMP-R ATTN: CERD-C ATTN: CERD-ZA ATTN: CERD-L ATTN: CERD-M ATTN: DAEN-ZC ATTN: DAIM-FDP	USA Natick RD&E Center 01760 ATTN: STRNC-DT ATTN: DRDNA-F	US Army HSC Fort Sam Houston 78234 ATTN: HSL0-F Fitzsimons Army Medical Ctr ATTN: HSHG-DPW 80045
CECPW 22310-3862 ATTN: CECPW-E ATTN: CECPW-FT ATTN: CECPW-ZC	US Army Materials Tech Lab ATTN: SLCMT-DPW 02172	Tyndall AFB 32403 ATTN: HQAFCEA Program Ofc ATTN: Engrg & Srvc Lab
US Army Engr District ATTN: Library (41) ATTN: CESASEC	USARPAC 96858 ATTN: DPW ATTN: APEN-A	Randolf AFB 78150-4321 ATTN: HQ AETC/GEOE
US Army Engr Division ATTN: Library (11) ATTN: CEHND-ED-ME-T	Area Engineer, AEDC-Area Office Arnold Air Force Station, TN 37389	USA TSARCOM 63120 ATTN: STSAS-F
INSCOM ATTN: IALOG-I 22060 ATTN: IAV-DPW 22186	HQ USEUCOM 09128 ATTN: ECJ4-LIE	American Public Works Assoc. 64104-1806
USA TACOM 48397-5000 ATTN: AMSTA-XE	AMMRC 02172 ATTN: DRXMR-AF ATTN: DRXMR-WE	US Army CHPPM ATTN: MCHB-DE 21010
Defense Distribution Region East ATTN: ASCE-WI 17070-5001	CEWES 39180 ATTN: Library	US Gov't Printing Office 20401 ATTN: Rec Sec/Deposit Sec (2)
Defense Distribution Region West ATTN: ASCW-WG 95296-0100	CECRL 03755 ATTN: Library	Nat'l Institute of Standards & Tech ATTN: Library 20899
HQ XVIII Airborne Corps 28307 ATTN: AFZA-DPW-EE	USA AMCOM ATTN: Facilities Engr 21719 ATTN: AMSMC-EH 61299 ATTN: Facilities Engr (3) 85613	Defense General Supply Center ATTN: DGSC-WI 23297-5000
4th Infantry Div (MECH) 80913-5000 ATTN: AFZC-FE	USAARMC 40121 ATTN: ATZIC-EHA	Defense Construction Supply Center ATTN: DCSC-WI 43216-5000
US Army Materiel Command (AMC) Alexandria, VA 22333-0001 ATTN: AMCEN-F Installations: (20)	Fort Leonard Wood 65473 ATTN: ATSE-DAC-LB (3) ATTN: ATZT ATTN: ATSE-CFLO ATTN: ATSE-DAC-FL ATTN: Australian Liaison Office	US Navy NCEL CODW L72 ATTN: NFESC Code 21
FORSCOM Forts Gillem & McPherson 30330 ATTN: FCEN Installations: (21)	Military Dist of WASH Fort McNair ATTN: ANEN 20319	Defense Tech Info Center 22060-6218 ATTN: DTIC-O (2)
6th Infantry Division (Light) ATTN: APVR-DE 99505 ATTN: APVR-WF-DE 99703	USA Engr Activity, Capital Area ATTN: Library 22211	
TRADOC Fort Monroe 23651 ATTN: ATBO-G Installations: (20)	US Army ARDEC 07806-5000 ATTN: AMSTA-AR-IMC	
Fort Belvoir 22060 ATTN: CETEC-IM-T ATTN: CETEC-ES 22315-3803 ATTN: Water Resources Support Ctr	Engr Societies Library ATTN: Acquisitions 10017	
	Defense Logistics Agency ATTN: MMDIS 22060-6221	
	Walter Reed Army Medical Ctr 20307	
	National Guard Bureau 20310 ATTN: NGB-ARI	
	US Military Academy 10996 ATTN: MAEN-A ATTN: Facilities Engineer ATTN: Geography & Envr Engrg	
	Naval Facilities Engr Command ATTN: Facilities Engr Command (8) ATTN: Division Offices (11) ATTN: Public Works Center (8) ATTN: Naval Constr Battalion Ctr 93043 ATTN: Naval Facilities Engr Service Center 93043-4328	
	416th Engineer Command 60623 ATTN: Gibson USAR Ctr	

233
6/97