

NAVAL POSTGRADUATE SCHOOL Monterey, California



THESIS

DTIC QUALITY INSPECTED 4

**DEVELOPMENT OF A
SURVIVABILITY AND LETHALITY
ASSESSMENT CENTER (SLAC)
AT NPS**

by

Gary G. Bishop

September 1996

Thesis Advisor:

Robert E. Ball

CO-Advisor:

Gordon E. Schacher

19970710 035

Approved for public release; distribution is unlimited.

REPORT DOCUMENTATION PAGE

Form Approved
OMB No. 0704-0188

Public reporting burden for this collection of information is estimated to average 1 hour per response, including the time for reviewing instructions, searching existing data sources, gathering and maintaining the data needed, and completing and reviewing the collection of information. Send comments regarding this burden estimate or any other aspect of this collection of information, including suggestions for reducing this burden, to Washington Headquarters Services, Directorate for Information Operations and Reports, 1215 Jefferson Davis Highway, Suite 1204, Arlington, VA 22202-4302, and to the Office of Management and Budget, Paperwork Reduction Project (0704-0188), Washington, DC 20503.

1. AGENCY USE ONLY (Leave blank)

2. REPORT DATE
September 1996

3. REPORT TYPE AND DATES COVERED
Master's Thesis

4. TITLE AND SUBTITLE

DEVELOPMENT OF A SURVIVABILITY AND LETHALITY ASSESSMENT CENTER (SLAC) AT NPS

5. FUNDING NUMBERS

6. AUTHOR(S)

Bishop, Gary G.

7. PERFORMING ORGANIZATION NAME(S) AND ADDRESS(ES)

Naval Postgraduate School
Monterey, CA 93943-5000

8. PERFORMING ORGANIZATION REPORT NUMBER

9. SPONSORING/MONITORING AGENCY NAME(S) AND ADDRESS(ES)

10. SPONSORING/MONITORING AGENCY REPORT NUMBER

11. SUPPLEMENTAL NOTES

The views expressed in this thesis are those of the author and do not reflect the official policy or position of the Department of Defense or the U.S. Government.

12a. DISTRIBUTION/AVAILABILITY STATEMENT

Approved for public release; distribution is unlimited.

12b. DISTRIBUTION CODE

13. ABSTRACT (Maximum 200 words)

The purpose of this thesis is to develop a Survivability and Lethality Assessment Center (SLAC) at the Naval Postgraduate School. Students, faculty, and staff from many different curricula can use the SLAC for thesis research, for validating their own computer codes, and for classroom instruction. The models for the SLAC were obtained from the Survivability/Vulnerability Information Analysis Center (SURVIAC), Teledyne Brown Engineering, Menton, Inc (for Grumman A/C Systems Advanced Programs), and from the Physics Department at the Naval Postgraduate School. Computer Systems in the SLAC include two SUN SPARC-10 Workstations, one Silicon Graphics Indigo, eight VAX6310 terminals with four graphics display consoles, eight IBM compatible computers, and two Macintosh computers. The SLAC now contains 24 models for running simulations. The SLAC is a comprehensive, user-friendly center for individuals or groups that need to use it. The security processing, computer account set-up, and documentation have all been streamlined to facilitate ease of use. Students, faculty, and staff should have no difficulty utilizing the SLAC.

14. SUBJECT TERMS

Survivability, Lethality, Assessment Center, Simulation, Air Defense

15. NUMBER OF PAGES

64

16. PRICE CODE

17. SECURITY CLASSIFICATION OF REPORT
Unclassified

17. SECURITY CLASSIFICATION OF THIS PAGE
Unclassified

17. SECURITY CLASSIFICATION OF ABSTRACT
Unclassified

20. LIMITATION OF ABSTRACT
UL

Approved for public release; distribution is unlimited.

DEVELOPMENT OF A
SURVIVABILITY AND LETHALITY
ASSESSMENT CENTER (SLAC)
AT NPS

Gary G. Bishop
Lieutenant, United States Navy
B.S. Rensselaer Polytechnic Institute, 1989

Submitted in partial fulfillment of the requirements for the degree of

MASTER OF SCIENCE IN APPLIED PHYSICS

from the

NAVAL POSTGRADUATE SCHOOL
September 1996

Author:

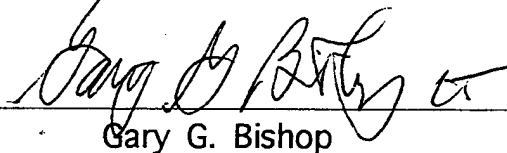

Gary G. Bishop

Approved by:

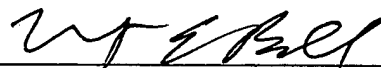

Robert E. Ball, Thesis Advisor



Gordon E. Schacher, Co-Advisor

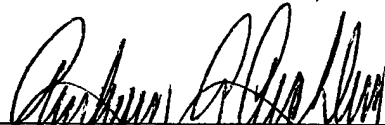

Anthony A. Atchley, Chairman
Department of Physics

ABSTRACT

The purpose of this thesis is to develop a Survivability and Lethality Assessment Center (SLAC) at the Naval Postgraduate School. Students, faculty, and staff from many different curricula can use the SLAC for thesis research, for validating their own computer codes, and for classroom instruction. The models for the SLAC were obtained from the Survivability/Vulnerability Information Analysis Center (SURVIAC), Teledyne Brown Engineering, Menton, Inc (for Grumman A/C Systems Advanced Programs), and from the Physics Department at the Naval Postgraduate School. Computer Systems in the SLAC include two SUN SPARC-10 Workstations, one Silicon Graphics Indigo, eight VAX6310 terminals with four graphics display consoles, eight IBM compatible computers, and two Macintosh computers. The SLAC now contains 24 models for running simulations. The SLAC is a comprehensive, user-friendly center for individuals or groups that need to use it. The security processing, computer account set-up, and documentation have all been streamlined to facilitate ease of use. Students, faculty, and staff should have no difficulty utilizing the SLAC.

TABLE OF CONTENTS

I. INTRODUCTION	1
A. MODELS AND SIMULATION	1
1. Definitions	1
2. DOD Acquisition Policy	3
3. The SMART VV&A Project	5
B. MODELS AND SIMULATION AT NPS	6
C. MODELS AND SIMULATION IN SURVIVABILITY AND LETHALITY	8
D. SURVIAC	10
E. THE SLAC AT NPS	10
II. DEVELOPMENT OF THE SLAC AT NPS	13
A. SECURE COMPUTING FACILITIES	13
B. THE MODELS	15
1. AASPEM: Air-to-Air System Performance Model	15
2. ALARM: Advanced Low Altitude Radar Model	16
3. BLUEMAX: Variable Airspeed Flight Path Generator ..	16
4. COVART: Computation of Vulnerable Area and Repair Time	17
5. ESAMS: Enhanced Surface-to-Air Missile Simulation .	17
6. FASTGEN: Fast Shotline Generator	18
7. HELIPAC: Helicopter Piloted Air Combat Model	18
8. IMARS: Integrated Missile and Radar Simulation	19

9.	McPTD: RCS Computation Based on Physical Theory of Diffraction	19
10.	RADGUNS: Radar-Directed Gun Simulation	20
11.	SCAN: Target Vulnerability Model	20
12.	TRAP:Trajectory Analysis Program	20
13.	DIME: Umbrella Model Program	21
14.	EADSIM: Extended Air Defense Simulation	21
15.	Other Models	22
C.	THE COMPUTERS	23
1.	Models on the VAX	23
2.	Models on the SGI	24
3.	Models on the SUN	25
4.	Models on the PCs/MACs	25
D.	ADVERTISING THE SLAC	25
III.	EADSIM	27
A.	INTRODUCTION	27
B.	INSTALLATION AND ACCESS FOR THE USERS	28
C.	MODELING THE DIFFERENT ASPECTS OF AIR DEFENSE	29
D.	BASELINE SCENARIOS FOR STUDENTS	32
IV.	FUTURE IMPROVEMENTS IN THE SLAC	33
A.	INTEGRATING DEPARTMENTAL LEARNING	33
B.	DEVELOPING CLASSES THAT UTILIZE THE SLAC	34
C.	ADDITIONAL MODELS/CAPABILITIES	35

APPENDIX A: SLAC SECURITY CLEARANCE FORM	37
APPENDIX B: PROCEDURES FOR USING THE SLAC	39
APPENDIX C: POINTS OF CONTACT FOR THE SLAC	41
LIST OF REFERENCES	43
INITIAL DISTRIBUTION LIST	45

LIST OF FIGURES

Figure 1. WarLab Annex Computer Layout	13
--	----

LIST OF TABLES

Table 1. EADSIM General Areas Modeled.	27
---	----

LIST OF ABBREVIATIONS, ACRONYMS, AND SYMBOLS

A/C	Aircraft
AAM	Air-to-Air Missile
AASPEM	Air-to-Air System Performance Model
AD	Air Defense
ALARM	Advanced Low Altitude Radar Model
AOR	Area of Responsibility
BLUEMAX	Variable Airspeed Flight Path Generator
C ²	Command and Control
C ⁴ I	Command, Control, Communication, Computers, Intelligence
COVART	Computation of Vulnerable Area and Repair Time
CW	Continuous Wave
DIME	Umbrella Program that Runs Multiple Models
EADSIM	Extended Air Defense Simulation
EMCON	Emissions Control
ESAMS	Enhanced Surface-to-Air Missile Simulation
FASTGEN	Fast Shotline Generator
FEZ	Fighter Engagement Zone
GB	Gigabyte
HELIPAC	Helicopter Piloted Air Combat Model
HUMINT	Human Intelligence
IMARS	Integrated Missile and Radar Simulation
IMINT	Imaging Intelligence
JTCG/AS	Joint Technical Coordinating Group — Aircraft Survivability
JTCG/ME	Joint Technical Coordinating Group — Munitions Effectiveness

IR	Infra-Red
M&S	Modeling and Simulation
MB	Megabyte
McPTD	RCS Computation Based on Physical Theory of Diffraction
MEZ	Missile Engagement Zone
MORS	Military Operations Research Society
MTI	Moving Target Indicator
NPS	Naval Postgraduate School
PACAM	Piloted Air Combat Analysis Model
P_H	Probability of Hit
P_K	Probability of Kill
PM	Program Manager
PRF	Pulse Repetition Frequency
P_S	Probability of Survival
RADGUNS	Radar-Directed Gun Simulation
RAM	Random Access Memory
RCS	Radar Cross Section
S/N	Signal-to-Noise
SAM	Surface-to-Air Missile
SCAN	Target Vulnerability Model
SIGINT	Signature Intelligence
SLAC	Survivability and Lethality Assessment Center
SMART	Susceptibility Model Assessment and Range Test
SURVIAC	Survivability/Vulnerability Information Analysis Center
TRAP	Trajectory Analysis Program
VV&A	Verification, Validation, and Accreditation

ACKNOWLEDGEMENTS

I would like to thank Distinguished Professor Robert E. Ball for his assistance, once again, with my thesis. His guidance, ideas, and financing were instrumental in the completion of this project.

I would also like to thank Professor Gordon E. Schacher for being a part of this thesis. His background in simulations and models helped start this project and guide it along the right path.

The staff of the WarLab, Patricia Franco, Ed Nath, and all the enlisted personnel in the Annex, also deserve special mention. They helped a great deal with the dirty work—working on the different computer systems and setting up the programs.

Finally, I would like to express my deep appreciation to my wife, Debbie, and my daughter, Megan, for their patience with me while I completed this second thesis. The time I spent away from home will pay for itself in the long run!

I. INTRODUCTION

A. MODELS AND SIMULATION

1. Definitions

The discipline of models and simulations is very dynamic. Computer programs are becoming more and more complex every day. In the 1980s, a program was considered enormous when it reached 100,000 lines of code. Today's larger simulations are run on models that contain over one million lines.

As the computer programs become larger, and many more fields of science and engineering become involved, the definitions of this discipline seem to become more vague. After reviewing several sources, this thesis will use the following as definitions, taken from the third chapter of an advance copy of CAPT Wayne Hughes', USN (ret) new book (yet to be titled) dealing with models and simulations:

model: a physical, mathematical, or otherwise logical representation of a system, entity, phenomenon, or process.

simulation: a method of implementing a model over time. Also, a technique for testing analysis, or training in which real-world and conceptual systems are reproduced by a model.

live simulation: a simulation in which real people operate real systems.

virtual simulation: simulation in which real people operate simulated systems. Virtual simulation injects the human-in-the-loop in a central role by exercising motor control skills, decision skills, or communication skills.

fidelity: the "trueness" of the model's representation of the physics compared to real life scenarios. Perfect fidelity means that the model predicts absolute truth.

analysis: exercises a set of assumptions and inputs in a model to give results and conclusions.

study: a comprehensive examination of a problem, including an analysis. A study should comment on the incommensurables the analysis did not treat. Typically a study contains recommendations.

client: the beneficiary of the analysis or study: the sponsor, the initiator, or any decision maker who draws from the effort. Sometimes, "the client" is a heirachry of decision makers or a committee.

The following three definitions are taken from the first issue of *SmarTalk*, Volume 1, Number 1 which referenced the Military Operations Research Society (MORS):

verification: the process of determining that a model implementation accurately represents the developer's conceptual description and specifications.

validation: the process of determining the extent to which a model is an accurate representation of the real-world from the perspective of the intended uses of the model.

accreditation: an official determination that a model is acceptable for a specific purpose.

2. DOD Acquisition Policy

According to Department of Defense's acquisition directive found in DoD 5000.1 (1996), modeling and simulation:

"...shall be used to reduce the time, resources, and risks of the acquisition process and to increase the quality of the systems being acquired. Representations of proposed systems (virtual prototypes) shall be embedded in realistic, synthetic environments to support the various phases of the acquisition process, from requirements determination and initial concept exploration to the manufacturing and testing of new systems, and related training."

The above quote from the Secretary of Defense's directive states that models and simulation will be utilized. The document goes on to state that models and simulation will be used throughout the life-cycle of the system. The Program Manager (PM) is responsible for ensuring that this takes place. He is also responsible for integrating modeling and simulation across the functional disciplines of the developed system.

The Secretary of Defense, by making the above statements, emphasizes that modeling and simulations (M&S) will be an integral part of defense acquisition, to reduce time and cost when performing tests and evaluations of weapon systems. This policy also extends into the war rooms and classrooms. With the complexity of models growing every day, it is easy for an operations officer or a student to plan out and simulate a battle scenario.

There will be few that will doubt that running a simulation is much less expensive than waging war. However, as the complexity of models increase, the fidelity of the model must keep pace. Developers of models, and those running simulations, must be aware that the results are only as good as the code. Verification, validation, and accreditation (VV&A) is a difficult process. The rule of thumb is: the more complex a model, the less fidelity; the simpler the model, more fidelity.

3. The SMART VV&A Project

The SMART Verification, Validation, and Accreditation (VV&A) Project was started at the China Lake Naval Air Warfare Center. Its purpose is to provide users of survivability models all the information that they need to accredit those models for their specific purposes. In other words, SMART provides all the necessary data for verification and validation, including range test data, to users to aid them in meeting their systems requirements.

Using the definitions from Section A-1 of this Chapter, verifying a model is finding out if it is performing the way that the user wants it to. Validating a model is determining how well the model does what the user wanted it to—comparing the model's predictions to reality. Accreditation is the decision by the users that the model is acceptable for them.

The SMART Project Office is responsible for the verification and validation (V&V) of the models used in survivability and vulnerability. The process of V&V is achieved by breaking each of the models primary functions into several functional elements (e.g. the model RADGUNS has a primary function of target characteristics which is broken down into the flight path, signature RCS static, signature RCS dynamic, signature fluctuations, ECM noise onboard, etc...). Each of these functional elements

are then analyzed separately. A verification and validation is performed for each functional element. Once that is done, the functional elements are re-combined into their original functions and the V&V process is applied again. Once this is done, the V&V process is performed with all the functions operating together.

The SMART Project Office issues reports to the users of the models upon completion. The reports issued contain all the information that a user needs for deciding on whether or not accreditation can be given for a particular model. Currently, the SMART Project Office is performing the V&V process on the following models: ALARM, ESAMS, and RADGUNS.

B. MODELS AND SIMULATION AT NPS

Models and simulation are used throughout the educational and research programs at NPS. Some of the technical areas include weather forecasting, wargaming, weapon effects, and ship, aircraft, and weapon analysis and design. Of interest to the author is the models and simulations for the survivability of United States military platforms and the lethality of U.S. weapons. Of particular interest is the survivability of aircraft and the lethality of air defense weapons.

NPS currently has no single organization for information exchange and coordination of models and simulation capabilities on campus. In the fall of 1992, Distinguished Professor Robert E. Ball and Professor Jim Taylor were formally asked by Dean Gordon Schacher to organize the different disciplines at NPS by starting an "NPS Modeling and Simulation Group." Faculty and staff from the Operations Research, Mechanical Engineering, Mathematics, Aeronautical Engineering, National Security Affairs, Physics, Electrical Engineering, Computer Science, and the Joint C⁴I Department initially participated in the new NPS M&S Group. After a few meetings, the group quit meeting due to the many different interests of the disciplines. Finding a common theme of interest to everyone proved to be too difficult.

As a consequence of the difficulties in creating a common thread for the total models and simulations at NPS, the models reside at many locations throughout the campus. However, there are two centers for M&S, the Visualization Lab (VisLab) and the WarLab. The VisLab is a non-secure visualization facility that serves the high-performance computing and visualization needs of NPS. The WarLab is a secure computing facility that contains four SUN Workstations, three IBM compatibles, and 30 VAX6300 terminals. The WarLab is used by the Operations Research Department for

simulations and classified theses. The WarLab's Annex is an extension of the WarLab on the fourth floor of Ingersoll Hall. It contains a greater variety of operating systems than does the WarLab.

C. MODELS AND SIMULATION IN SURVIVABILITY AND LETHALITY

The following definitions are based on the rough draft edition of *The Fundamentals of Aircraft Combat Survivability Analysis and Design*, by Distinguished Professor Robert E. Ball:

survivability: the capability of a weapon system platform to avoid and/or withstand a man-made hostile environment.

lethality: the capability of a weapon system to encounter, engage, and kill an enemy target.

Both terms can also be defined by probabilities since both involve stochastic processes. Survivability is the probability that a platform will survive a man-made hostile environment, denoted as P_S . To do this, the platform must keep from being hit by the enemy weapon system, P_H , and if hit, it must not die (must not be killed), $P_{K/H}$.

The opposite (the complement) to survivability is lethality. It is the probability that a weapon system will kill the enemy target. This probability is denoted as P_K .

For a given encounter between a platform and a weapon system, the platform will either survive or it will be killed. Therefore, the two probabilities are related by the following equation:

$$P_S + P_K = 1 \quad (1.1)$$

Since probabilities represent stochastic behavior by definition, the use of computers has become vital to survivability/lethality analysis. A computer model can be written to analyze one or many aspects of warfare between a weapon and a platform—the target.

This thesis presents the process the author used to gather the latest versions of the models use by DOD and the U.S. aircraft industry and install them in the Survivability and Lethality Assessment Center (SLAC) at NPS. Chapter II of this thesis will describe several of the models that are currently being utilized in the United States to conduct simulations involving aircraft and air defense weapons. Chapter III will feature the model EADSIM—Extended Air Defense Simulation—and its capabilities.

EADSIM is currently used extensively at the U.S. Strategic Command at Offutt AFB in Omaha, Nebraska. Chapter IV will discuss possibilities for further development of the SLAC at NPS.

D. SURVIAC

SURVIAC is the Survivability/Vulnerability Information Analysis Center. It is sponsored by the Joint Technical Coordinating Groups on Aircraft Survivability and Munitions Effectiveness (JTTCG/AS and JTTCG/ME). It is a centralized resource for all information pertaining to non-nuclear survivability, vulnerability, lethality, and mission effectiveness. The Center disseminates its information to Department of Defense activities as requested.

The information disseminated is in the form of computer models, libraries, methodologies, and databases. Both government sources and their contractors can request this information from SURVIAC. This thesis selected SURVIAC's computer models for inclusion into the SLAC.

E. THE SLAC AT NPS

The SLAC was initially established in 1992. The Director of the SLAC is Distinguished Professor Robert E. Ball. It became an official NPS

Research Center in 1993. This thesis describes a major updating of the models in the SLAC and their organization into one location—the Annex.

The choice to use the NPS WarLab's Annex as the site for the SLAC was made out of convenience. There had to be a spot on campus that had computing facilities that were cleared up through the SECRET level. There are currently three places that would have fit this bill—the SCIF in Root Hall, the WarLab's main facility on the first floor in Ingersoll Hall, and the WarLab Annex on the fourth floor of Ingersoll Hall. The Annex's current under-utilization made it the best choice. Also, its secluded nature and the fact that it is staffed during normal working hours make it more attractive for use by students working on thesis projects.

The development of the SLAC at NPS is the attempt to help the different departments coordinate their computer models and simulations activities on campus. With the WarLab Annex as the home to the SLAC, there is a central location for all computer models to be installed. This thesis has dealt mainly with installing models that pertain to survivability and lethality. However, there is room for the expansion of other models into the SLAC. With one central location, the different curricula throughout the school can share resources (computers, printers, advisors) and more easily perform interdisciplinary work.

II. DEVELOPMENT OF THE SLAC AT NPS

A. SECURE COMPUTING FACILITIES

The WarLab Annex is located on the fourth floor of Ingersoll Hall and can only be accessed by the elevator with a secure key lock. The Annex computing facilities are contained inside one room. Figure 1 below is a sketch of the contents of the Annex.

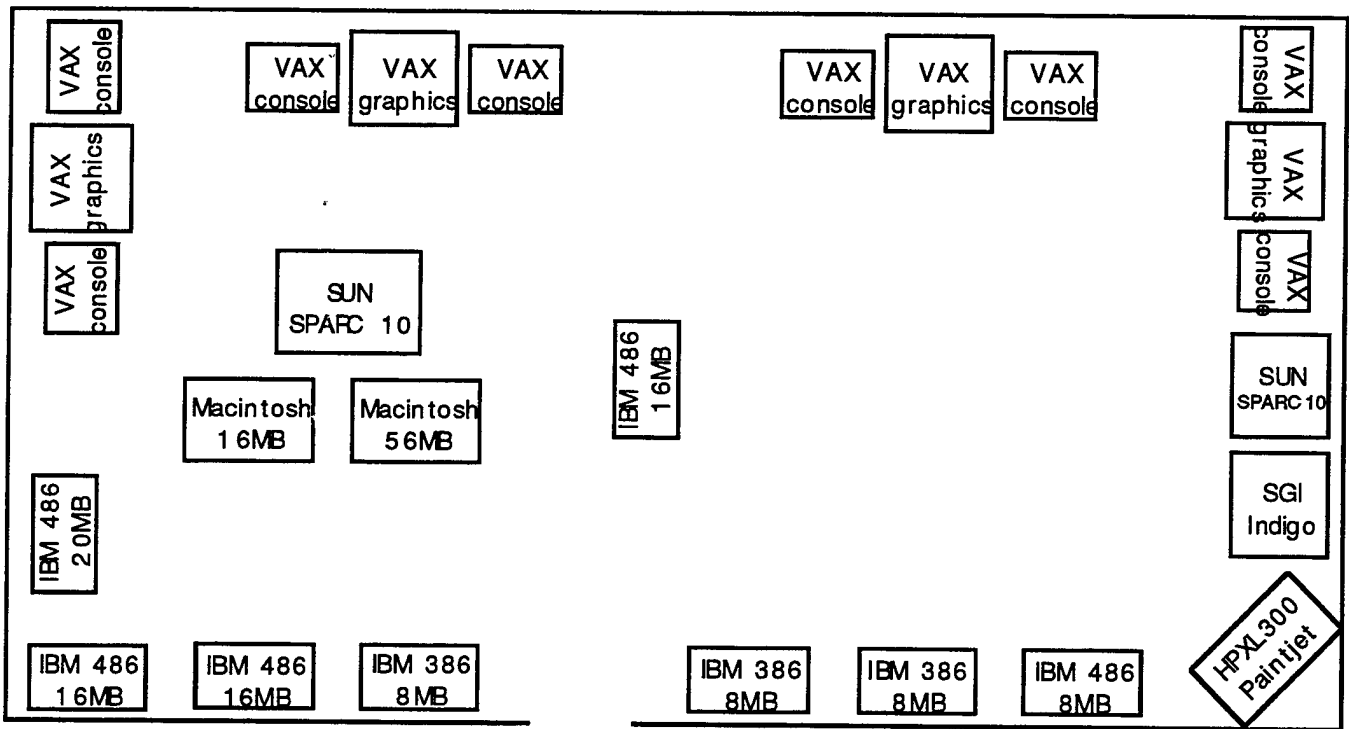

Figure 1. WarLab Annex Computer Layout

The WarLab Annex contains one Silicon Graphics Indigo which runs system 5.3. It has been upgraded to 64 MB of RAM. There are two SUN SPARC 10 Workstations running Open Windows operating system.

The mainframe computer, a VAX 6310, has eight consoles for use in input/output. For each pair of consoles, there is an associated graphics display console which enhances the output of the simulations. The Annex also contains eight IBM compatible computers, five 486DXs and three 386SXs. Four of the five 486s contain at least 16 MB of RAM, the rest 8 MB. The two Macintosh computers (based on the Motorola 68040 processor) have 56 MB and 16 MB of RAM.

All the computers are hooked up via ethernet to the Hewlett-Packard XL300 Paintjet printer. The workstations (both SGI and SUNs) are also connected to a laser printer.

The entire room of the Annex is located on a raised platform (eight inches off the floor) to allow for easy installation of wiring. The room is also air conditioned. There is one emergency access to the roof of Ingersoll Hall.

B. THE MODELS

The latest versions of the following models were obtained from SURVIAC. A more descriptive brochure of the models can be found in the Reference Manual Cabinet inside the SLAC.

1. AASPEM: Air-to-Air System Performance Model

This model enables a user to preform air combat analysis in a realistic few-on-few scenario. Utilizing Air Force specified missile guidance laws and propulsion characteristics, missiles and aircraft can be simulated. The math model is a five degree of freedom (DOF) and can handle up to 75 different air vehicles during a simulation trial.

AASPEM is a conglomeration of four integrated sub-models: 1) Advanced Missile Flyout Model, 2) Aircraft, Missile, Avionics Performance Simulation, 3) Interactive Tactical Air Combat Simulation, and 4) Automatic Decision Logic Tactical Air Combat Simulation.

Limitations: Since each of the weapons/aircraft are created in a separate file, care must be taken when creating the scenario to ensure that their interdependency has been accounted for.

2. ALARM: Advanced Low Altitude Radar Model

ALARM is a model that simulates the capabilities of a ground-based radar system against air targets. The model is capable of simulating the following radar types: pulsed (low PRF), pulsed with moving target indication (MTI), pulse-doppler (high PRF), and continuous wave (CW). ALARM use detailed forms of the radar range equation to determine the ability of the system to detect the target in the presence of terrain, clutter, and multipath.

Limitations: This is not a waveform level model.

3. BLUEMAX: Variable Airspeed Flight Path Generator

This model generates trajectory data for use as input data into other model programs such as ESAMS, EADSIM, or RADGUNS. Aircraft status is defined by the following variables: time, three space coordinates, three components of velocity, roll angle, g-factor, throttle setting, fuel remaining, speed-brake setting, and the number of external stores modules carried.

Limitations: The pilot is assumed to have absolute control over the time derivatives of roll rate, g-factor rate, throttle setting, and speed braking. These are the only inputs for aircraft maneuvering.

4. COVART: Computation of Vulnerable Area and Repair Time

The vulnerable areas and repair times caused by a single penetrator can be calculated using COVART. The model can analyze fixed-wing, rotary-wing, or ground targets. Inputs for the penetrators size, speed, and direction can be input using FASTGEN or manually done with a data file. P_K for critical components are also input through a data file.

Limitations: Exploding penetrators are not modeled; shotlines are all parallel; blast effects, ricochet, and spall are not modeled.

5. ESAMS: Enhanced Surface-to-Air Missile Simulation

ESAMS simulates a single air target vs a single SAM site. Detailed data and intelligence has provided very detailed representation of Soviet SA-2 through SA-15 and the naval SAMs SA-N-1, SA-N-3, SA-N-4, SA-N-6, SA-N-7, and SA-N-9 missile systems.

The model takes into account the target's flight path, observables, countermeasures, vulnerable areas, and blast contours. The model simulates the SAM's detection, launch, target tracking, and ECCM capabilities. The missile's flyout, aerodynamics, guidance/control, fuzing, blast, and fragmentation are developed for the weapon.

Limitations: It is a one-on-one simulation (however, this enables the fidelity of the program to be much greater than if it simulate many-on-many).

6. FASTGEN: Fast Shotline Generator

Generates shotline data for vulnerable area calculations such as used by COVART. This method of simulation assumes parallel rays through the target from the point of detonation. The input file requires a geometric description of the target using adjacent triangles, spheres, cones, ellipsoids, and rods.

Limitations: The input file description of the target aircraft is difficult to model.

7. HELIPAC: Helicopter Piloted Air Combat Model

Simulates performance, flight dynamics (3-D), and body rates and trims for helicopters. Simulations can be run for a helicopter vs another helicopter or a fixed-wing aircraft.

Limitations: The model has limited sensor capabilities and does not account for all clutter and background effects in low altitude flight.

8. IMARS: Integrated Missile and Radar Simulation

This model consists of three components: 1) a missile flyout module, 2) a monopulse radar module, and 3) a multi-path module. The three components together simulate realistic multi-path and clutter effects. The model also simulates the detection and tracking of the target and the launch of the interceptor.

The model simulates the following SAM sites: SA-5, SA-6, SA-8, SA-10, SA-11, SA-12, SA-14, and SA-15.

Limitations: The model can run only one input set at a time and it does not model countermeasures.

9. McPTD: RCS Computation Based on Physical Theory of Diffraction

McPTD performs far-field, single-bounce RCS modeling for high frequency radars based on the physical theory of diffraction. McPTD contains sixteen codes which allow the user to construct different geometric shapes, including cavities and shadowing. McPTD does allow the user to define up to 20 layers of coatings (uniform or non-uniform).

Limitations: Computes only single-bounce RCSs—there is no computation for component interaction.

10. RADGUNS: Radar-Directed Gun Simulation

RADGUNS contains a collection of programs that simulate target detection tracking, and shooting performances of several anti-aircraft artillery weapon systems against a passive aerial target. These models can be run with a Monte Carlo simulation option, randomizing clutter, multipath, and glint. P_H and P_K are calculated using distribution theory.

Limitations: This model simulates only one-on-one scenarios with no reactive maneuvering capabilities for the aircraft.

11. SCAN: Target Vulnerability Model

This program predicts the probability that an aircraft will survive an attack by a missile armed with a fragmentation warhead. The program simulates the encounter between an aircraft and a missile and computes the expected target damage.

Limitations: SCAN does not model blast effects.

12. TRAP: Trajectory Analysis Program

TRAP is a general purpose model that simulates the flight of SAMs, Air-to-Air Missiles (AAMs), and Unmanned Aerial Vehicles (UAVs). The model allows the user to choose between three, five, or six degrees of

freedom. The TRAP output is often used as input information for larger programs such as AASPEM.

Limitations: TRAP does not model endgame effects.

13. DIME: Umbrella Model Program

This is a shell program that combines several of the SURVIAC models with some new programs into a common program with standardized input and output formats. The programs include AASPEM, ALARM, BLUEMAX, CMG, ESAMS, GRACE, RADGUNS, and TRAP.

The following model is not in the SURVIAC library yet. It was obtained from Teledyne-Brown Engineering in Huntsville, Alabama.

14. EADSIM: Extended Air Defense Simulation

Simulates theater missile defense, and air defense architectures, as well as weapon systems in the full context of an environment of sensors, C² centers, communications systems, platform dynamics, and weapons performance. It models both Red and Blue forces and is graphics-based, user-oriented, and highly versatile. (A more detailed description is provided in Chapter III).

15. Other Models

The models listed below are from various sources and do not have the accreditation that the other SURVIAC models have.

GRACE: Ground and Atmospheric Clutter Evaluation.

Provides clutter mapping for various radars based on terrain and atmospheric effects.

PACAM: Piloted Air Combat Analysis Model

Simulates many aspects of air-to-air warfare. The fixed-wing version of HELIPAC.

JSEM: Target Vulnerability Model

Simulates the effects of a proximity-fuzed detonation of a high explosive warhead on an air target.

PC TRAP: Trajectory Analysis Program for the IBM Compatible

This is a PC version of TRAP that is installed on the VAX mainframe. The FORTRAN code was translated for a PC compiler.

CIWS Scattering Model

This program was developed by the Physics Department to simulate the scatter pattern of the Vulcan Phalanx CIWS. The model also simulates the trajectory and paths of the major fragments after missile break-up.

Laser Propagation Model

This program was developed by the Physics Department to simulate the propagation of a free-electron laser beam as it passes through the atmosphere. It allows the user to place optical surfaces in the propagation path to change the effects of weather, particles in the air, and thermal blooming.

CWM: Composite Warfare Module

Theater Ballistic Missile Simulation program developed by Menton, Inc. for Grumman Aircraft.

C. THE COMPUTERS

1. Models on the VAX

The following models are located on the VAX:

AASPEM: Air-to-Air System Performance Model

COVART: Computation of Vulnerable Area and Repair Time

FASTGEN: Fast Shotline Generator

HELIPAC: Helicopter Piloted Air Combat Model

IMARS: Integrated Missile and Radar Simulation

McPTD: RCS Computation Based on Physical Theory of

Diffraction

PACAM: Piloted Air Combat Analysis Model

JSEM: Target Vulnerability Model

TRAP: Trajectory Analysis Program

2. Models on the SGI

The following models are located on the SGI:

EADSIM: Extended Air Defense Simulation

DIME: Umbrella Model Program

AASPEM: Air-to-Air System Performance Model

ALARM: Advanced Low Altitude Radar Model

BLUEMAX: Variable Airspeed Flight Path Generator

CSG: Composite Signature Generator

ESAMS: Enhanced Surface-to-Air Missile Simulation

GRACE: Ground and Atmospheric Clutter Evaluation

RADGUNS: Radar-Directed Gun Simulation

SCAN: Target Vulnerability Model

TRAP: Trajectory Analysis Program

3. Models on the SUN

The following models are located on the SUN workstation:

CIWS Scattering Model

Laser Propagation Model

4. Models on the PCs/MACs

The following models are located on the IBM compatibles:

PC TRAP: Trajectory Analysis Program (for IBM PCs)

JSEM: Target Vulnerability Model

COVART: Computation of Vulnerable Area and Repair Time

The following model is located on the Macintosh:

CWM: Composite Warfare Module

D. ADVERTISING THE SLAC

Another goal of the author was to publicize the SLAC. The following text appeared on 26 September, 1996 in the *Campus News*, the weekly newspaper of the Naval Postgraduate School:

On the 1st of October, the NPS/NAVAIR Survivability and Lethality Assessment Center (SLAC) will be available for use by students/faculty/staff. The SLAC is a secure computing facility located on the fourth floor of Ingersoll Hall (yes, there is a fourth floor). The purpose of the SLAC is to provide users with computer simulation software for modeling different aspects of survivability and lethality in battle. Students can use the SLAC's computer models to aid them in completing their theses by generating data for analysis or validating their own computer programs.

The SLAC has multiple computer platforms available for use by the users: VAX mainframe with multiple terminals, a Silicon Graphics IRIS Indigo, two SUN

Workstations, several PCs, and two Macintosh computers. These computers store the 15 software programs now available in the SLAC. These programs, of which most are sponsored by the Joint Technical Coordinating Group on Aircraft Survivability (JTTCG/AS), include:

Air-to-Air System Performance Model (AASPEM): simulates many aspects of air-to-air warfare

Advanced Low Altitude Radar Model (ALARM): determines the detection performance of a ground based radar

Variable Airspeed Flight Path Generator (BLUEMAX III): simulates an aircraft flight path based upon user inputs and aircraft performance data

Computation of Vulnerable Area and Repair Time (COVART): calculates vulnerable areas and repair times for a single penetrator, such as a fragment or projectile

Enhanced Surface-to-Air Missile Simulation (ESAMS): simulates a one-on-one engagement between an aircraft and a Soviet SAM

Fast Shotline Generator (FASTGEN): generates the shotline data required by COVART for a given target

Helicopter Piloted Air Combat Model (HELIPAC): simulates helicopter performance limits, flight dynamics, and body rates and trim

Integrated Missile and Radar Simulation (IMARS): simulates a one-on-one engagement between an aircraft and a Soviet SAM

RCS Computation Based on Physical Theory of Diffraction (McPTD): computes the high frequency radar cross section of a target

Piloted Air Combat Analysis Model (PACAM): simulates many aspects of air-to-air warfare

Radar-Directed Gun Simulation (RADGUNS): simulates a one-on-one engagement between an aircraft and numerous AAA systems

Target Vulnerability Model (JSEM): simulates the effects of a proximity-fuzed detonation of a high explosive warhead on an air target

Trajectory Analysis Program (TRAP): simulates the flyout of a missile toward a maneuvering air target

Extended Air Defense Simulation (EADSIM): simulates one-on-one to many-on-many from the blue or red forces perspective (over 1 million lines of code)

For those interested in utilizing the SLAC (you must have at least a Secret security clearance), go to room 135 (War Lab) in Ingersoll Hall to fill out a security access sheet and get a retinal scan. This will allow access to the fourth floor War Lab Annex and the SLAC. All documentation for the software programs is located in a clearly marked cabinet in the Annex. Additionally, the Annex is staffed with personnel to answer questions you may have. For more information, please contact the SLAC Director, Distinguished Professor Robert E. Ball of the Aeronautical & Astronautical Engineering Department.

III. EADSIM

A. INTRODUCTION

EADSIM is an analytic model of air and missile warfare developed by Teledyne-Brown Engineering and is used for scenarios ranging from one-on-one to many-on-many. It is unique with respect to the other models identified in Chapter II in that each platform (e.g. missile, fighter aircraft) is modeled individually. The interactions between platforms are also modeled independently. EADSIM also models the command and control (C²) decision processes and the communications among the platforms on a message-by-message basis. Intelligence gathering is explicitly modeled and the intelligence information used in both offensive and defensive operations. In Table 1, a list of the general areas that have been modeled. Part C of this Chapter describes in more detail the different levels.

Air Defense	Early Warning
Offensive Air Operations	Generic Non-combatants
Attack Operations	Communications
Multi-Stage Ballistic Missiles	Electronic Warfare
Air Breathers	Terrain
Sensors	Weaponry
Jammers	Areas of Interest
Satellites	

Table 1. EADSIM General Areas Modeled.

One of the features of EADSIM which supports a wide variety of scenarios is the ability to play any feature for either side. Simultaneous offensive and defensive operations by both sides are supported in any combination. This allows a full range of realistic scenarios to be investigated and is one of the primary reasons for the wide application of EADSIM. That is why the actual definition of a scenario is a very tedious process.

The amount of data that is generated is very large for even a minor scenario. This is another strength of EADSIM. It not only allows for the generation of the scenarios, but it also allows for the post-processing and analysis of the resulting data.

B. INSTALLATION AND ACCESS FOR THE USERS

EADSIM was installed on the Silicon Graphic Indigo in the SLAC. Several problems occurred during the initial installation. Teledyne Brown has a toll-free help line (800.C4I.USER) for registered users which was invaluable during this debugging phase.

EADSIM was installed as a separate computing account. It therefore has its own login id and its own password. This was done so that new users did not have to have separate SGI accounts set up. The login id is

"EADSIM" and the password can be obtained from the administrator during the initial familiarization tour.

C. MODELING THE DIFFERENT ASPECTS OF AIR DEFENSE

The general areas that have been modeled by EADSIM, discussed in section A of this chapter, can be broken down further. Table 2 below is the list of different models and the different sub-categories that can be defined explicitly by a user.

- Air Defense
 - Surface-to-Air Missiles
 - Anti-Air
 - Anti-Missile
 - Upper and Lower Tiers
 - Anti-Air Artillery
 - Command and Control
 - Air Picture Production and Dissemination

- Offensive Air Operations (including a/c acceleration, dynamics, and terrain following)
 - Defensive Counter Air Fighters
 - Offensive Counter Air
 - Close Air Support
 - Suppression of Enemy Air Defenses (including Wild Weasels)
 - Offensive and Defensive Command and Control
 - TBM Engagements by a/c (boost phase, pre- and post-apogee)
 - Aerial Refueling
 - Airbase Operations

- Attack Operations
 - Surveillance
 - Command and Control

Surface-to-Surface
Air-to-Surface
Intelligence Gathering and Processing
Movement, concealment, and protection/hardening

- Multi-stage Ballistic Missiles (including methodologies, launch schemes, scheduling, and atmospheric parameters)
- Air Breathers
 - Aircraft (to include waypoints, aerial refueling, low-level transits, and wingman modes)
 - Cruise Missiles
 - Helicopters
- Sensors (including search modes, post detection modes, resource management, and additional capability/calculations for compound sensors. This also includes detection gate criteria, RCS determination, S/N ratio, ground clutter, track qualities, and tracking errors)
 - Radar
 - Infrared
 - SIGINT, IMINT, HUMINT
 - Launch Detection
 - Radar Warning Receiver
- Jammers (including methodology and interfaces to detection and propagation)
 - Sensors
 - Communications
- Satellites (including definitions, methodologies, and coordinate systems)
- Early Warning
- Generic Non-combatants

- Communications (including message generation, message transmission and reception, and network descriptions)
 - Networks
 - Devices
 - Individual Messages
- Electronic Warfare (to include EMCON procedures and responses)
 - Jamming of Sensors and Communications
 - SIGINT Detection supporting attack ops and active defense
 - Passive detection of radars
 - Adaptive radars, sidelobe suppression
 - Chaff, flares, decoys
- Terrain
 - Sensor Masking
 - Communication Propagation
 - Flight/Movement
- Weaponry (conventional and nuclear)
 - Air-to-air
 - Air-to-surface
 - Surface-to-air (including weapon definition and propagation rules)
 - Surface-to-surface
- Areas of Interest
 - Missile Engagement Zone (MEZ)
 - Fighter Engagement Zone (FEZ)
 - Area of Responsibility (AOR)
 - Tactical Area of Interest (TAI)
 - Tactical Action Line
 - Theater Missile Defense Area (TMDA)
 - Friendly Origin (FOR)
 - Defense Alert Zone

It is easy to see that the user has a great deal of input to how the simulation will run.

D. BASELINE SCENARIOS FOR STUDENTS

In June 1993, Neil R. Bourassa, a student at the Naval Postgraduate School, finished a thesis titled, *Modeling and Simulation of Fleet Air Defense Systems Using EADSIM*. This thesis developed two scenarios to be used with the AA3705 (Air Defense Lethality) and AA3251 (Combat Aircraft Survivability) classes. The scenarios could be run and displayed as animated playback files for analysis. Students in the classes would be able to modify the original scenarios and rerun the battles. The AD Lethality students would try to improve on the P_K of its weapons systems while the Survivability students would try to improve on their aircraft's capability to keep from being hit and killed.

The scenarios developed by Bourassa are located in the NPS Simulation Laboratory on the first floor of Ingersoll Hall. However, there has been difficulty in the past trying to get these models to run on the older machines. There is a possibility that a student would be able to gain access to the scenarios, copy them to disk, and then install them in the SLAC. A student could then modify the original programs to take advantage of the major improvements that have occurred in EADSIM over the last four years.

IV. FUTURE IMPROVEMENTS IN THE SLAC

A. INTEGRATING DEPARTMENTAL LEARNING

The SLAC has enough computer models to simulate all aspects of air defense. For the Physics Department, it has models to simulate the effectiveness of radars, IR imaging systems, weapon effects of surface-to-air missiles, and weather propagation characteristics. For the Aeronautical Engineering Department, the models can be used to simulate the trajectory of a missile or aircraft, the vulnerable area of an attacking aircraft, the radar cross section of an aircraft, and the performance/dynamics capabilities of helicopters. For the Operations Research/Analysis Department, the SLAC can be utilized to simulate one-on-one battles between an aircraft and a SAM site, many-on-many aircraft battles, and major campaign analysis for a theater level war.

It is easy to see that the SLAC is of great use to many different disciplines at NPS. If the students and/or professors wanted to combine the study of some project, it would be easy to undertake. An example would be the improvement in an air defense set-up for a high value U.S. asset. A Physics student could design a different type of high powered radar system that was able to pick up attacking aircraft at a greater

range. The Aeronautical Engineering student that was designing missile systems would then work on a control system with tracking information being passed from the new radar. The Physics student that was working on the warhead design of the missile would then use the models to optimize the fragment spray pattern. The Operations Research student would analyze the system as a whole to see if it is an improvement to current operating units.

In this example, this one project (which could be a multi-student thesis project) is an interdisciplinary one. Many departments would be able to improve a system instead of just one. As the acquisition process of major defense programs turns towards integrated product teams, thesis projects here at NPS can also.

B. DEVELOPING CLASSES THAT UTILIZE THE SLAC

With the opening of the new and improved SLAC in October, the faculty of NPS will have an additional tool to aid them in teaching their classes. Currently, only the Operations Research Department uses the WarLab on a regular basis. The Physics Department will have the ability to incorporate the use of models/simulations in the PH2911/PH4911 sequence. The two classes are being taught to teach students how to

program (in C code) physical weapon systems. If PH4911 were changed so that the last three weeks of the class utilized the SLAC, the professor could show the class how different models consolidate the techniques learned in lectures.

Military students at NPS will rarely have to generate code for simulations. However, they will definitely be required to know how to use them. They will also be required to know how to best simulate an aspect of war. Using the models in the SLAC will enable them to see how changing different parameters change the outcomes of the simulations. The professor can then discuss the modeling methods utilized by the programmers, and suggest better methods if applicable.

C. ADDITIONAL MODELS/CAPABILITIES

The WarLab Annex has many computers that contain many models for simulating all aspects of survivability and lethality. However, more codes are being generated every day along with improvements to the current versions. The SLAC is a central point for collecting all these capabilities.

The other aspect of improvement recommended for the SLAC is in the computing facilities. As the models become more and more complex, they take more powerful machines on which to run. For example, EADSIM is

being run on the Silicon Graphics Indigo which has 64 MB of RAM. The developers at Teledyne Brown use machines with 512 MB of RAM.

USSTRATCOM located at Offutt AFB in Omaha, Nebraska run EADSIM on machines with up to 2.0 GB of RAM. For NPS to operate effectively, a budget should be developed to keep the systems upgraded.

APPENDIX A

SLAC SECURITY CLEARANCE FORM

SECURE COMPUTING AND SIMULATIONS LABORATORY (SCSL), IN-157
SCSL ANNEX A, IN-P3/P4

REQUEST FOR UNESCORTED ENTRY/ACCESS

INSTRUCTIONS: Requester should FILL OUT PART 1 ONLY and return to the SCSL Security Manager, IN-157, phone 3011/3012.

1. REQUEST.

Reason for access _____
Last Name _____ First Name _____ MI _____
Rank/Title (e.g., LT, MR, PROF) _____ Departure Date (MM/DD/YY) _____
SSN _____ SMC/Code _____ Service (e.g., USN, USA, CIV, FAC) _____
Curric #/Dept (e.g., 361, 530, OR, PH) _____ Curric/Dept Phone _____
Sponsor Code _____
(Printed Name & Signature of Sponsor)

2. CLEARANCE CERTIFICATION. (TO BE COMPLETED BY THE SCSL SECURITY MANGER.) It is hereby certified that the above named individual has the following level of security clearance on file at the Naval Postgraduate School.

(Clearance) (Signature/Title) (Date)

3. AUTHORITY. The above named applicant has a need-to-know, and is hereby granted access to the Operations Research SCSL and/or the SCSL Annex A.

(Signature/Title) (Date)

4. DISPOSITION. I have read the NPS Secure Computing and Simulations Laboratory Security Manual, and have been briefed on the security procedures appropriate to the category of access granted me. I agree not to circumvent access controls, to protect my User ID/Password, and to report any accidental or intentional unauthorized entry to the proper authority. I further understand that any Laboratory property which is issued to me must be returned when access is no longer required, or prior to my departure from the Naval Postgraduate School.

(Signature of Applicant) (Date) (Witness) (Date)

ACCESS INFO:	
SCSL (IN-157)	Annex A (IN-P3/P4)
EyeDent #: _____	_____
Type Access: _____	_____

LOCKER INFO:
Locker #: _____
Lock #: _____

DEFINITION OF USER CATEGORIES

MASTER USER - An individual authorized to open, assume custody of, and secure the NPS SCSL and/or the SCSL Annex A.

LIMITED USER - An individual authorized unescorted access to the NPS SCSL and/or the SCSL Annex A during normal working hours, or when otherwise occupied by a Master User.

APPENDIX B PROCEDURES FOR USING THE SLAC

If a student, faculty, or staff member of NPS (referred to as a user) desires to use the SLAC, the user should go to Room I35 in Ingersoll Hall—the NPS WarLab. There is a phone outside in the passageway with instructions for calling the supervisor inside the WarLab. The supervisor will come out and let the user inside.

Once inside, the supervisor will ask to see the user's identification card and will check it against the school's master security listing from the security office. If the user is on the list and has at least a SECRET clearance, he/she will be asked to fill out a "REQUEST FOR UNESCORTED ENTRY/ACCESS" form. A copy of this form is included in Appendix A.

After the form has been filled out, the supervisor will take the user to the fourth floor using the elevator on the East side of Ingersoll Hall. The user will be given the security code to operate the elevator (there is no button for the fourth floor—the elevator will automatically proceed to the fourth floor when the correct security code is entered). When the elevator comes to a stop, the rear doors open to a small passageway.

In the passageway, the supervisor will scan the retina of the new user using the EyeDent security system outside the Annex's door. Once the scan is complete, the user will have limited access to the Annex— he/she may use the Annex when there are staff personnel present. This is indicated by a green light above the door and an "OPEN" sign hanging on the door.

The supervisor will then escort the user inside and give a brief tour of the facilities. The supervisor will add the user to the VAX system and to the UNIX workstation. The models contained on the SGI, MACs, and PCs are accessed by entering the correct id and password for the particular model on the log in screen. Once the supervisor has given the tour and created the new accounts, the user is ready for running simulations.

All of the information for running the simulations is contained in one cabinet by the Macintosh computers. In this cabinet, a user will find user's manuals, reference books, addendums, and tutorials. The user should find the information applicable to the models that will be utilized and review them thoroughly.

During normal working hours (0730-1630), the WarLab Annex is staffed with personnel to assist the users. Any questions about the computers or models should be directed to them. If the staff cannot answer the questions directly, they will assist the user in finding the person that will.

APPENDIX C

POINTS OF CONTACT FOR THE SLAC

Distinguished Professor Robert E. Ball, Director, SLAC
Code AA/Bp
Department of Aeronautics and Astronautics
Naval Postgraduate School
Monterey, CA 93943-5100
(408) 656-2556
ball@aa.nps.navy.mil

Professor Gordon E. Schacher, Physics Department Simulations
Code PH/Sq
Department of Physics
Naval Postgraduate School
Monterey, CA 93943-5100
(408) 656-3776

Mr. Ed Nath, Computer Programmer/Analysist
Naval Postgraduate School
Monterey, CA 93943-5100
(408) 656-3014

Ms. Patricia Franco, Computer Programmer/Analysist
Naval Postgraduate School
Monterey, CA 93943-5100
(408) 656-3011

LIST OF REFERENCES

1. Ball, R.E., *The Fundamentals of Aircraft Combat Survivability Analysis and Design*, AIAA, 1985.
2. Ball, R.E., *Air Defense Lethality*, Class Notes, September 1995.
3. Ball, R.E., *Combat Aircraft Survivability*, Class Notes, March 1996.
4. Bourassa, N.R., *Modeling and Simulation of Fleet Air Defense Systems Using EADSIM*, M.S. Thesis, Naval Postgraduate School, Monterey, California, June 1993.
5. Teledyne Brown Engineering, *Extended Air Defense Simulation (EADSIM) User's Manual*, June 1996.
6. Booz/Allen & Hamilton, *Survivability/Vulnerability Information Analysis Center SURVIAC Model Guide*, 1991.
7. Perry, William, *Department of Defense 5000 Series*, March 15, 1996.
8. Hughes, Wayne P., *Advanced Copy of New Book—Chapter Three*, August, 1996.
9. Chaney, Richard, *Defense Modeling and Simulation Initiative*, May 1, 1992.
10. Naval Air Warfare Center Weapons Division, *SmartTalk*, Vol. III, Number 1, 1st quarter FY95.
11. Naval Air Warfare Center Weapons Division, *SmartTalk*, Vol 1, Number 1, 3rd quarter FY93.

INITIAL DISTRIBUTION LIST

	No. copies
1. Defense Technical Information Center 8725 John J. Kingman Rd., STE 0944, Ft. Belvoir, VA 22060-6218.	2
2. Dudley Knox Library Naval Postgraduate School 411 Dyer Rd. Monterey, CA 93943-5101	2
3. Professor Robert E. Ball Code AA/Bp Department of Aeronautics and Astronautics Naval Postgraduate School Monterey, CA 93943-5100	1
4. Professor Gordon E. Schacher Code PH/Sq Department of Physics Naval Postgraduate School Monterey, CA 93943-5100	1
5. CDR Michael Witt Code 33 Naval Postgraduate School Monterey, CA 93943-5100	2
6. LT Gary G. Bishop 315 Bogey Dr Abingdon, VA 24210	2