

**UNITED STATES AIR FORCE  
ARMSTRONG LABORATORY**

---

**STUDIES AND ANALYSES OF AUTOMATED  
SYSTEMS FOR EVIDENCE ACCRUAL**

**Pamela McCauley-Bell  
Rhonda Freeman**

**BELL ENGINEERING CONSULTING  
315 SUNCREST COURT  
OVIEDO, FL 32765**

**MARCH 1997**

**INTERIM REPORT FOR THE PERIOD APRIL 1996 TO MARCH 1997**

19970728 077

**DIC QUALITY INSPECTED 4**

*Approved for public release; distribution is unlimited.*

**Crew Systems Directorate  
Human Engineering Division  
2255 H Street  
Wright-Patterson AFB OH 45433-7022**

## NOTICES

When US Government drawings, specifications, or other data are used for any purpose other than a definitely related Government procurement operation, the Government thereby incurs no responsibility nor any obligation whatsoever, and the fact that the Government may have formulated, furnished, or in any way supplied the said drawings, specifications, or other data, is not to be regarded by implication or otherwise, as in any manner licensing the holder or any other person or corporation, or conveying any rights or permission to manufacture, use, or sell any patented invention that may in any way be related thereto.

Please do not request copies of this report from the Armstrong Laboratory. Additional copies may be purchased from:

National Technical Information Service  
5285 Port Royal Road  
Springfield, Virginia 22161

Federal Government agencies and their contractors registered with the Defense Technical Information Center should direct requests for copies of this report to:

Defense Technical Information Center  
8725 John J. Kingman Road, Suite 0944  
Ft. Belvoir, Virginia 22060-6218

### TECHNICAL REVIEW AND APPROVAL

AL/CF-TR-1997-0060

This report has been reviewed by the Office of Public Affairs (PA) and is releasable to the National Technical Information Service (NTIS). At NTIS, it will be available to the general public, including foreign nations.

This technical report has been reviewed and is approved for publication.

**FOR THE COMMANDER**

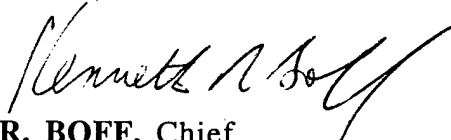

**KENNETH R. BOFF**, Chief  
Human Engineering Division  
Armstrong Laboratory

# REPORT DOCUMENTATION PAGE

Form Approved  
OMB No. 0704-0188

Public reporting burden for this collection of information is estimated to average 1 hour per response, including the time for reviewing instructions, searching existing data sources, gathering and maintaining the data needed, and completing and reviewing the collection of information. Send comments regarding this burden estimate or any other aspect of this collection of information, including suggestions for reducing this burden, to Washington Headquarters Services, Directorate for Information Operations and Reports, 1215 Jefferson Davis Highway, Suite 1204, Arlington, VA 22202-4302, and to the Office of Management and Budget, Paperwork Reduction Project (0704-0188), Washington, DC 20503.

1. AGENCY USE ONLY (Leave blank)	2. REPORT DATE March 1997	3. REPORT TYPE AND DATES COVERED Interim, April 1996-March 1997	
4. TITLE AND SUBTITLE  Studies and Analyses of Automated Systems for Evidence Accrual		5. FUNDING NUMBERS  C: F41624-94-D-6000 PE: 62202F PR: 7184 TA: 10 WU: 46	
6. AUTHOR(S)  Pamela McCauley-Bell, Rhonda Freeman		8. PERFORMING ORGANIZATION	
7. PERFORMING ORGANIZATION NAME(S) AND ADDRESS(ES)  Bell Engineering Consulting 315 Suncrest Court Oviedo, FL 32765		10. SPONSORING/MONITORING  AL/CF-TR-1997-0060	
9. SPONSORING/MONITORING AGENCY NAME(S) AND ADDRESS(ES)  Armstrong Laboratory, Crew Systems Directorate Human Engineering Division Human Systems Center Air Force Materiel Command Wright-Patterson AFB OH 45433-7022		11. SUPPLEMENTARY NOTES	
12a. DISTRIBUTION/AVAILABILITY STATEMENT  Approved for public release; distribution is unlimited.		12b. DISTRIBUTION CODE	
13. ABSTRACT (Maximum 200 words)  Information warfare presents new challenges to the warfighter. Critical decisions must be made under conditions of severe time stress based on information which may be incomplete, inaccurate, and of uncertain latency. The study explores the possible application of Fuzzy Set Theory to the possible improvement of decision maker performance under these conditions.			
14. SUBJECT TERMS  Information Warfare, Decision Making, Fuzzy Set Theory		15. NUMBER OF PAGES 41	
17. SECURITY CLASSIFICATION OF REPORT  UNCLASSIFIED		16. PRICE CODE	
18. SECURITY CLASSIFICATION OF THIS PAGE  UNCLASSIFIED	19. SECURITY CLASSIFICATION OF ABSTRACT  UNCLASSIFIED	20. LIMITATION OF ABSTRACT  UNLIMITED	

This page intentionally left blank.

## PREFACE

This project was completed for Armstrong Laboratory, Crew System Integration Branch, under contract F41624-94-0-6000 for Logicon Technical Services, Inc. The researchers would like to acknowledge Mr. Gil Kuperman for his initial interest, support, and direction in the application of this nontraditional approach to the very important issue of uncertainty management. We also wish to thank Mr. John Smith for thorough and patient project management and technical guidance. Finally, but certainly not least, extensive appreciation is extended to Dr. Randall D. Whitaker, Dr. Tipton N. Patton, and Mr. Robert L. Stewart for the exceptional technical guidance and input they continually offered.

## ABSTRACT

The information age is transforming military operations by providing soldiers, marines, sailors, and airmen with unprecedented quantities of information whose quality may vary from low to high. The plethora of information has increased the demands on the humans in the system, and this in turn has emphasized the need to understand how the user accrues the information in an attempt to ameliorate the effects of the elevated level of demand. This problem is enhanced when the information or evidence that must be accrued is susceptible to uncertainty (G. G. Kuperman, personal communication, 1996). The current project involved the characterization and analysis of uncertainty in evidence accrual, which may result from incomplete information, insufficient alternatives, or intentionally deceptive actions. The project utilized fuzzy set theory to manage and measure the uncertainty associated with evidence accrual. The Observe-Orient-Decide-Act (OODA) Loop was the cognitive model used to represent the stages through which an individual progresses during evidence accrual. The first two phases of the loop, which entail the initial sensing and management of information, were the primary focus.

## TABLE OF CONTENTS

	<u>PAGE#</u>
LIST OF FIGURES	vi
LIST OF TABLES	vii
INFORMATION WARFARE	1
WHAT IS INFORMATION?	1
INFORMATION WARFARE	2
INDIRECT VS. DIRECT IW	2
OODA LOOPS	3
UNCERTAINTY IN INFORMATION WARFARE	6
THREE TYPES OF UNCERTAINTY	6
CURRENT METHODS OF DEALING WITH UNCERTAINTY IN DECISION SUPPORT	7
TOP LEVEL MODEL OF EVIDENCE ACCRUAL USING FUZZY LOGIC	9
Stage 1	10
Stage 2	12
Stage 3	15
DISCUSSION	16
INTELLIGENCE ANALYST EXAMPLE	17
CONCLUSION	20
REFERENCES	21
APPENDIX	23
NUMERIC BASIS OF FST	23
FUZZINESS VS. PROBABILITY	27
MAPPING FUNCTIONS	29
S (sigmoid/logistic) mapping functions	30
$\pi$ mapping functions	30
Linear membership functions	31
GLOSSARY	33

## LIST OF FIGURES

<u>FIGURE#</u>	<u>TITLE</u>	<u>PAGE#</u>
1	The four phases of the OODA Loop.	4
2	Bayesian Combination Model of sensory uncertainty management (adapted from Waltz & Beude, 1986).	7
3	Dempster-Shafer Model of sensory uncertainty management.	8
4	Top level model of evidence accrual representing three types of uncertainty.	12
5	Three stages of the uncertainty model.	15
6	Detailed decomposition of Fuzzy Uncertainty Measurement Model.	16

## LIST OF TABLES

<u>TABLE#</u>	<u>TITLE</u>	<u>PAGE#</u>
1	Types of Fuzzy Uncertainty Classified in Evidence Accrual	6
2	Level of Deceptibility (LOD) Matrix Vulnerability of Information	11
3	Example Analysis	18
4	Stages of the Example Problem	19
5	Categorization of Crisp Outputs	20

This page intentionally left blank.

## INFORMATION WARFARE

Technological innovations begun in the 1970's have facilitated extraordinary improvements in methods for collecting, storing, analyzing, and transmitting information. Nations, corporations, and individuals all seek to increase and protect their own store of information while trying to limit and penetrate the adversary's. One way to characterize this area in a broad sense is to say that information warfare (IW) includes *"any action to deny, exploit, corrupt, or destroy the enemy's information and functions; protecting ourselves against those actions; and exploiting our own military information functions"* (Widnall & Fogleman, 1995). Although the topic of IW seems to be of great interest, it does yet have a standard definition within the military community (Szafranski, 1995). IW, a tool for promoting and maintaining national security, can be described in the broadest sense as the use of information to achieve our national objectives (Stein, 1995). Although technology has facilitated the explosion of this technique, it is important to note that *"...IW is fundamentally not about satellites, wires, and computers, but rather about influencing human beings and the decisions they make through the manipulation of pertinent information"* (Stein, 1995).

### What Is Information?

IW is intertwined with its root concept: information itself is derived from phenomena, which include observable facts, events, and actions. Before they can be elevated to information status, phenomena must be perceived and interpreted. Thus, the phenomena become information through observation and analysis. Because the shift from phenomena to information is the result of subjective perceptions and interpretations, the information that is received may vary widely from one individual to another. Thus, the next important aspect of appropriate information dissemination is the inclusion of useful instructions for interpretation. Information, then, is the result of perceived phenomena (data) and the instructions required to interpret that data and establish meaning. In the evidence accrual environment, the powers of observation are surveillance and reconnaissance; the bases for the orientation of those observations are intelligence and weather analysis. In the Air Force, the observations inform the decision makers who must plan the Air Tasking Order (ATO) for subsequent command and control operations.

## Information Warfare

War places special demands on the information functions of military operations. From the individual soldier to the theater level of war, IW is the discovery and exploitation of information. The goal is to seek, acquire, and protect information for personal benefit while simultaneously withholding or altering the information the adversary can access during decision making. IW consists of targeting the enemy's information and information functions, while protecting one's own, with the intent of degrading the enemy's capability or will to fight.

### Indirect vs. Direct IW

In the past, IW strategies typically relied on measures such as feints and deception to influence decisions by affecting the decision maker's perceptions. That is, these strategies influenced information through the perception process by attacking the enemy's information indirectly. For the deception to be effective, the enemy must:

- observe the deception,
- analyze the deception as reality, and
- act upon the deception according to the deceiver's goals.

This process is referred to as *indirect information warfare*. Using military deception, one could construct images of friendly forces, landscape differentials, and supporting evidence to present a realistic and convincing image. Although many technological manipulations are necessary for the success of this approach, it is important to remember that it ultimately relies on the adversary's observing the pseudo combat operation and interpreting it as real. Only then is it successful IW. The following methods may be used to accomplish the goal of deceiving the enemy with inaccurate sensory information:

- psychological operations that use information to affect the enemy's reasoning
- electronic countermeasures (ECM) that deny accurate information to the enemy

- military deception that misleads the enemy about our capabilities, resources, or intentions
- physical destruction of information system elements
- security measures that seek to prevent the adversary from learning about our military capabilities and intentions.

In contrast to indirect IW, *direct information warfare* enables one to change or create information without relying on observation and interpretation. For example, through information attack, a pseudo combat wing may be created directly in the adversary's store of information without the manipulation of sources that rely on effective transmission of the altered information. Theoretically, the result – deception – is precisely the same. This makes direct IW an attractive alternative to indirect IW because comparable, and potentially more reliable, results may be achieved with the additional advantage of reductions in the resources, time, and uncertainty associated with the process. The direct approach to IW is a targeted approach that can be considered “information attack.” Direct IW specifically targets the information with the intent of producing deception. Specifically,

- Information attack consists of directly corrupting information *without* visibly changing the physical entity in which it resides. Thus, information attack is the direct alteration of data or instructions.

### OODA LOOPS

The most frequently cited theoretical construct in the IW literature is the OODA Loop (Figure 1), a cyclical model unifying the perceptual, cognitive, and active factors involved in decision making (Boyd, 1987).

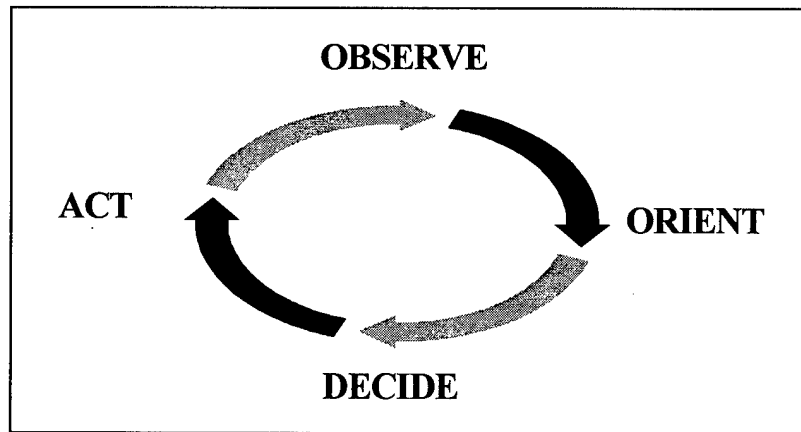

*Figure 1.* The four phases of the OODA Loop.

The OODA Loop illustrates the practical payoff of information dominance: the ability to act and react in an informed, knowledgeable manner more rapidly than the adversary. Achieving this advantage is considered operating within the enemy's decision cycle or OODA Loop. The following paragraphs describe the four individual phases comprising a unit OODA Loop with respect to an individual subject.

In the **Observe** (O) phase of an OODA Loop, the subject, operating within his/her role, engages phenomena in the environment within which he/she pursues the process. Observation consists of the subject's transformation of phenomena into a set of data. The Observe phase concludes when the subject begins integrating this data into his/her knowledge base.

In the **Orient** (O) phase of an OODA Loop, the subject, operating within his/her role, engages data deriving from observation. Orientation consists of distilling information from the data stream and integrating that information along with prior facts into a coherent state of situational knowledge. The Orient phase concludes at the point that the subject achieves this coherent state. Note that the criterion for completion of the Orient phase is a "coherence" of situational knowledge, not a "completeness" or "accuracy" of situational knowledge.

In the **Decide** (D) phase of an OODA Loop, the subject, operating within his/her role, engages situational knowledge deriving from orientation. Decision consists of evaluating this situational knowledge, projecting its ramifications for the process, focusing on a set of chosen

ramifications, and selecting actions appropriate to that focus. The Decide phase concludes when the subject moves from reflection on to enactment of the selected plan.

In the Act (A) phase of the OODA Loop, the subject, operating within his/her role, engages the environment with respect to the plan derived from the Decision phase. Action consists of transforming the abstract plan into instrumental behavior. The Act phase concludes when the subject completes or interrupts realization of the plan and begins observing the newly-changed state of the environment.

Several key features of the OODA Loop enhance its utility in human factors IW research. First, it explicitly identifies the decision cycle as a continuous process from perception (Observe) through cognition (Orient / Decide) to response (Act). The following points are introduced to qualify the abstract OODA model in preparation for its application to actual systems:

- 1) There is no presumption that an OODA Loop, once begun, will necessarily be completed.
- 2) Precise delineation of transitions from one phase to the next may appear context- or situation-dependent. As such, there may be variations among mappings of specific event behavior sequences onto the O-O-D-A phase sequence.
- 3) The boundaries between the four phases are not necessarily crisp. In other words, activities may take place in the Observe phase and continue into the early stages of the Orient phase.

The OODA model concentrates on the pattern and course of activities in an operational domain. This focus fits the scope and form of the issues in IW. Generally, applying an OODA approach is justified by the following: The OODA model prioritizes action over artifacts. The OODA model is a tool for addressing decision processes such as C4ISR, defined as "...the planning, tasking, and control of the execution of missions through an architecture of sensors, communications, automation, and intelligence support" (Widnall & Fogleman, 1995). The OODA model prioritizes practical theory over theories of practice.

## UNCERTAINTY IN INFORMATION WARFARE

### Three Types of Uncertainty

Uncertainty in problem solving situations may result from information deficiency, poor instruction, or an inability to discriminate among alternatives. This is particularly likely if the information is incomplete, fragmented, contradictory, unreliable, or vague. All of these concepts are most appropriately measured qualitatively; however, the most accepted techniques to manage uncertainty are quantitative (i.e., probability). Nonetheless, if reliable qualitative or quantitative measures of uncertainty are available, the amount of uncertainty in a problem solving situation may be reduced.

In the theater of operations, uncertainty can arise from limitations in sensor measurements and coverage. Uncertainty also results from conflicting reports produced by a variety of intelligence sources. The commander may also have problems with the “fog of war” and be unable to make certain decisions in the time needed due to numerous permissible courses of action. These types of uncertainty and others have made fuzzy modeling a useful tool for representing military decision making (Cisneros et al., 1995).

Three major types of uncertainty include *nonspecificity* (or imprecision), which is connected with sizes (cardinalities) of relevant sets of alternatives; *fuzziness* (or vagueness), which results from imprecise boundaries of fuzzy sets; and *strife* (or discord/strife), which involves conflicts among alternatives. Both nonspecificity and strife are subsets of a higher category of uncertainty, ambiguity. Ambiguity is associated with any situation in which there are numerous alternatives with no clear “best choice.” Table 1 details the uncertainty measures based on fuzzy logic used in this study and the type of uncertainty each measure represents.

Table 1

*Types of Fuzzy Uncertainty Classified in Evidence Accrual*

<b>Uncertainty Measure</b>	<b>Uncertainty Type</b>
<i>Hartley Function</i>	Nonspecificity
Fuzzy Union	Discord/Strife
<i>Hamming Distance</i>	Fuzziness

## Current Methods of Dealing with Uncertainty in Decision Support

Probabilities, fuzzy variables, and probability intervals are all used to represent the uncertainty associated with information used in decision making. The theoretical basis for crisp approaches to managing uncertainty is supported by a rich history of mathematical foundations. This, however, does not mean that more progressive approaches with less theoretical support are not capable of producing comparable results. The willingness to utilize these approaches has been primarily built on a basis of empirical and experiential activities. One drawback in theory acceptance in some decision making environments has been the lack of rigorous theory in non-traditional methods such as fuzzy set theory.

Currently, the Bayesian Combination Model and the Dempster-Shafer Model are among the most widely used approaches to the management of uncertainty in human decision making. As depicted in Figures 2 and 3, both models consist of numerical combination algorithms that merge multiple hypothesis data vectors from  $N$  sensors. The sensors include statistical classifiers that classify measured features into a vector of parameters. These parameters quantify the certainty (likelihood, degree of fit, etc.) that the measurements represent each hypothesis. For the Bayesian Combination Model, portrayed in Figure 2, the parameters are forward-conditional probabilities. Bayes' rule is used to derive a composite *a posteriori* probability. A decision rule, such as the maximum *a posteriori* (MAP), is then applied to select the most likely hypothesis.

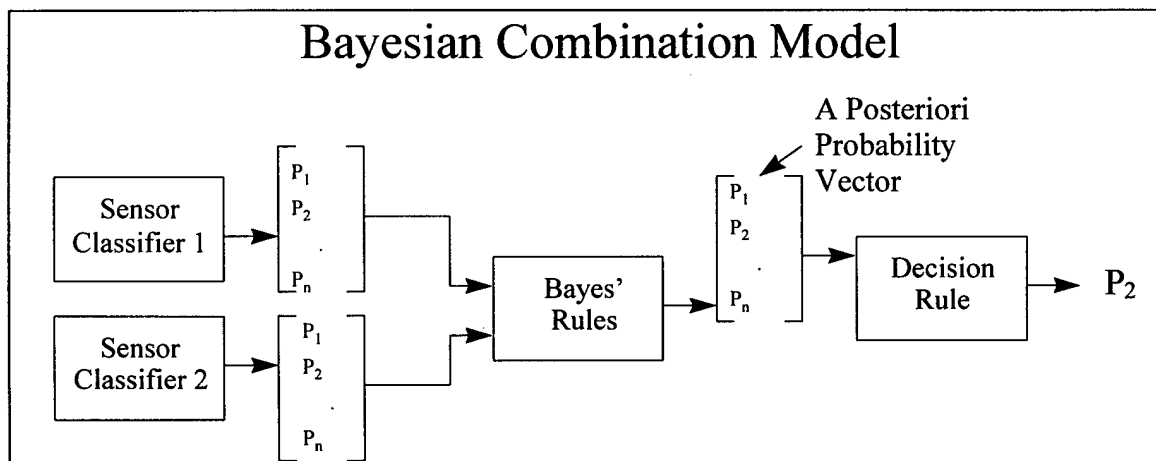

Figure 2. Bayesian Combination Model of sensory uncertainty management (adapted from Waltz & Buede, 1986).

The alternative Dempster-Shafer Model, represented in Figure 3, uses probability intervals to describe sensor data. The Dempster-Shafer Model of uncertainty, proposed by Dempster and modified by Shafer (1976), attempts to distinguish between ignorance and uncertainty. This model permits:

$$P(A) + P(B) \leq 1 \quad [1]$$

where  $P(A)$  and  $P(B)$  represent the strength of evidence or confidence

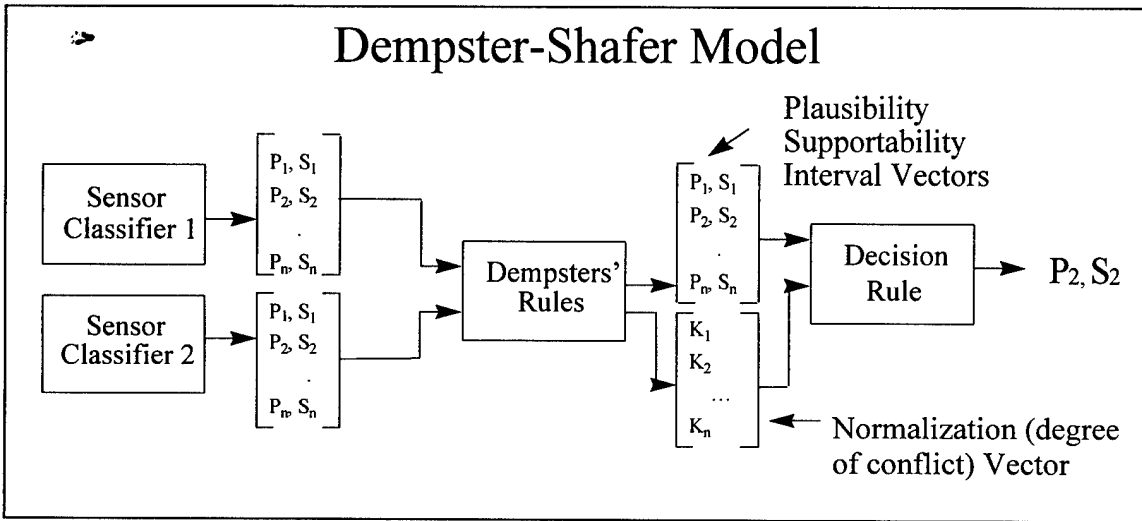

Figure 3. Dempster-Shafer Model of sensory uncertainty management.

Based on identifying the believability of a function or proposition, the function  $f$  represents the measure of belief committed to a given proposition or piece of sensory information.

Each hypothesis is represented by two parameters:

- 1) supportability ( $0 \leq S(X) \leq 1$ ) [2]

which describes the degree to which measurements support the hypothesis and

- 2) plausibility ( $0 \leq P(X) \leq 1$ ) [3]

which represents the degree to which the evidence fails to refute the hypothesis.

The difference between plausibility and supportability is measure of ignorance about the hypothesis:  $D(I) = P(x) - S(x)$ . [4]

When  $P(x) = S(x)$ , the probability interval collapses to a single probability equivalent to a forward conditional probability.

Dempster's rule of combination, analogous to Bayes' rule, provides a means of computing composite supportability/plausibility intervals (credibility intervals) for each hypothesis, reducing the uncertainty in the measured data. An appropriate decision rule is then applied on the basis of both supportability and plausibility.

#### Top Level Model of Evidence Accrual Using Fuzzy Logic

Fuzzy set theory is a viable alternative to the management of uncertainty in military decision-making environments that may produce a more realistic approach because linguistic values can be directly incorporated into this technique. A variety of approaches to data fusion and uncertainty management were explored (Llinas, 1996, Waltz & Buede, 1986). The developed methodology utilized for fuzzy management of uncertainty in this evidence accrual approach modifies data fusion frameworks established by Waltz and Buede (1986) to model the information processing flow. The methodology divides the processing of information received from the sensor into three stages, where each stage has a mechanism for representing the components' uncertainty.

**Stage 1** begins in the Observe Phase of the OODA Loop upon receipt of the sensor information from various classifiers. In **Stage 2**, the three measures of uncertainty are determined from the fuzzy rule base and aggregated to produce three categorical measures of uncertainty. This is related to the Orient Phase where the operator is attempting to attach significance to the information in order to make a decision. The uncertainty at this phase will again be evaluated. **Stage 3** is the development of the overall measure of uncertainty and is an aggregation of the three individual measures of uncertainty. The aggregation technique involves two stages of fuzzy rules.

Stage 1.

It is assumed that this model operates in discrete time increments and that the sensor classifiers will provide an output,  $S_n$ , whose value represents the measure of significance, or *value*, of the associated sensory information in making the required decision. This value is obtained for each individual piece of information. Each individual piece of information,  $S_n$ , will then be assigned a membership value,  $\mu_n$  ( $0 \leq \mu_n \leq 1$ ) that is used to represent the uncertainty associated with the information. This membership value will be a function of the Likelihood of Deceptibility (LOD). The LOD is a matrix which considers the likelihood that a piece of information is contaminated or its vulnerability to adversaries. The determination of LOD is based on the vulnerability of an information source as well as the medium through which it is transmitted. The basis of these linguistic assignments is extensive literature analysis and knowledge acquisition with military experts. An abbreviated example of the LOD is illustrated in Table 2. The vulnerability is measured qualitatively and takes the following factors into consideration:

- amount of information received
- type of information received: voice, record, data
- source of information: intelligence, acoustic, radar
- frequency of information
- situational awareness, which will be a sub-category for each combination of types of information and sources, is a function of environmental characteristics: high intensity environment, moderate intensity, and low intensity.

The linguistic category's values used to represent the likelihood that the information is deceptive include the following:

- Not likely to be deceptive (NL)
- Somewhat likely to be deceptive (SWL)
- Likely to be deceptive (L)
- Very Likely to be deceptive (VL)
- Extremely Likely to be deceptive (EL)

Subjective assignments have been made to each combination based on interaction with experts and literature analyses.

Table 2.

*Level of Deceptibility (LOD) Matrix Vulnerability of Information*

<b>Type of Information Received</b>				
	<b>Voice/ Interactive</b>	<b>Recorded</b>	<b>Alphanumeric Text</b>	<b>Dynamic Database or Knowledge Base</b>
<b>Intelligence</b>				
High Intensity	SWL	VL	VL	EL
Moderate Intensity	L	VL	VL	VL
Low Intensity	NL	L	VL	VL
<b>Electronic Intelligence</b>				
High Intensity	SWL	EL	EL	EL
Moderate Intensity	L	VL	VL	EL
Low Intensity	L	VL	VL	EL
<b>Acoustic</b>				
High Intensity	SWL	VL	N/A	VL
Moderate Intensity	NL	VL	N/A	L
Low Intensity	NL	L	N/A	L
<b>Radar</b>				
High Intensity	N/A	EL	VL	EL
Moderate Intensity	N/A	EL	VL	VL
Low Intensity	N/A	VL	L	VL

In Stage 1 of the model, these linguistic values are aggregated in order to produce a measure of uncertainty associated with each measure. The aggregation technique takes the form of a weighted sum where the products are the weights and the measures of uncertainty. Specifically, the weights are the respective “values” of the piece of information, as determined

from a pre-defined set of rules, times the uncertainty measure, which is a function of previously mentioned factors.

Stage 2.

The membership values will then be utilized by a fuzzy rule engine and persistent knowledge base to analyze, evaluate, and aggregate the membership values of the individual pieces of information with respect to the uncertainty associated with each. There will be two high level sets of fuzzy rules. One will determine via an  $\alpha$ -cutoff if the information has a value that will be useful to the situation assessment function. The second level will then be used to determine the values of the three types of uncertainty associated with each piece of information.

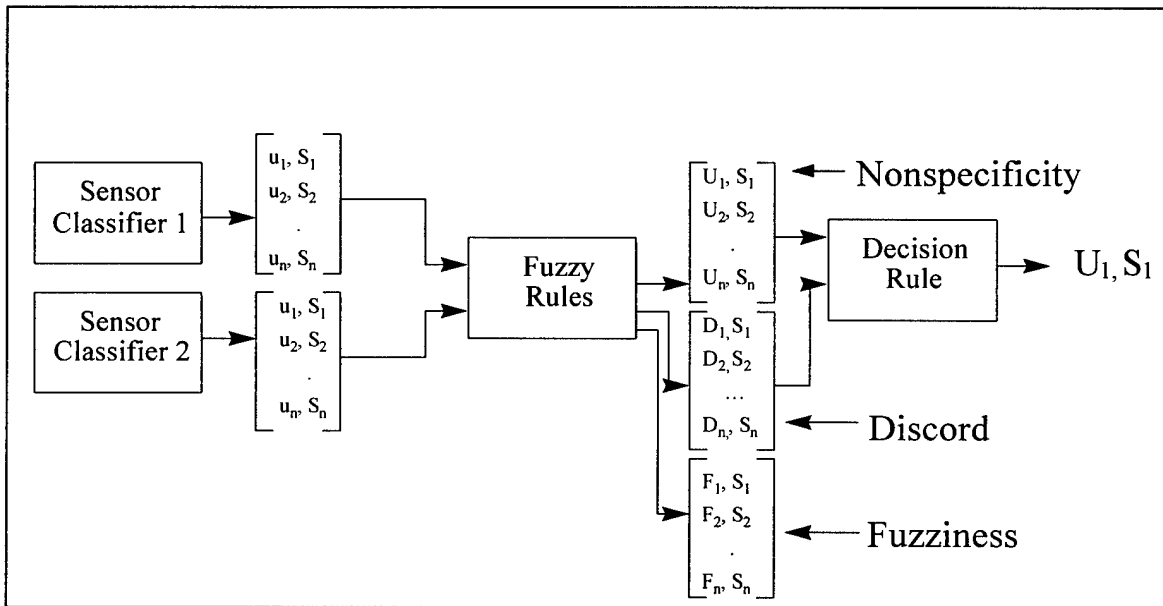

Figure 4. Top level model of evidence accrual representing three types of uncertainty.

The output from this stage will be vectors for nonspecificity, discord/strife, and fuzziness. Mathematically this will be represented by:

*Nonspecificity* =  $V_i = [U_1, U_2, \dots, U_n]$ . This uncertainty, which is characterized by two or more unspecified alternatives, results from variety, generality, diversity, equivocation, and imprecision. This component of the model is a necessary aspect of the uncertainty measure because it provides an assessment of the set with respect to the total information received. In this

case the function  $U$  defined as the *Hartley function* provides a unique approach to measure uncertainty associated with sets of alternatives (Klir & Yuan, 1995). For any non-empty fuzzy set  $A$  defined on a finite universal set  $X$ , the generalized Hartley function has the form

$$U(A) = \frac{1}{h(A)} \int_0^{h(A)} \log_2 |{}^\alpha A| \delta\alpha \quad [5]$$

Where  $|{}^\alpha A|$  denotes the cardinality of the  $\alpha$ -cut of  $A$  and  $h(A)$  is the height of  $A$ . Observe that  $U(A)$ , which measures nonspecificity of  $A$ , is a weighted average of values of the Hartley function for all distinct  $\alpha$ -cut of the normalized counterpart of  $A$ , defined by  $A(x)/h(A)$  for all  $x \in X$ . Each weight is a difference between the values of  $\alpha$  if a given  $\alpha$ -cut and the immediately preceding  $\alpha$ -cut.

$$\begin{aligned} &\text{For any } A, B \in \mathfrak{F}(X) - \{\emptyset\}, & [6] \\ &\text{if } A(x)/h(A) = B(x)/h(B) \\ &\text{for all } x \in X, \\ &\text{then } U(A) = U(B). \end{aligned}$$

That is, fuzzy sets that are equal when normalized have the same nonspecificity measured by function  $U$ . This operation will produce a fuzzy measure representing nonspecificity in this stage of the model.

*Discord/strife* =  $W_i = [D_1, D_2, \dots, D_n]$ . This type of uncertainty is characterized by disagreement in choosing among alternatives and results from dissonance, incongruity, discrepancy, and conflict. Although numerous approaches exist to obtain fuzzy unions (Yager, 1980), this value will be obtained by taking the general form of the union that takes the largest membership value contained within the set to represent the union. This yields the resulting maximal value of uncertainty from all the membership values, thus allowing this value to represent the level of discord/strife or uncertainty for the given set of sensor characteristics.

*Fuzziness* =  $X_i = [F_1, F_2, \dots, F_n]$ . This type of uncertainty is characterized by the absence of definite or sharp distinctions among alternatives. It can result from vagueness, cloudiness, or haziness as well as a lack of clarity, distinctness, or sharpness. Fuzziness will be obtained by using the *Hamming Distance*. The selected method for measuring fuzziness is to view the fuzziness of a set in terms of the lack of distinction between the set and its complement. This lack of distinction between the sets and their complements is the very factor that distinguishes fuzzy sets from crisp sets. The less a set differs from its complement, the fuzzier it is. In general, a measure of fuzziness is a function:

$$f: \mathfrak{F}(X) \rightarrow \mathfrak{R}^+ \quad [7]$$

where  $\mathfrak{F}(X)$  denotes the set of all fuzzy subsets of  $X$  (fuzzy power set).

For each fuzzy set  $A$ , this function assigns a nonnegative real number  $f(A)$  that expresses the degree to which the boundary of  $A$  is not sharp. To qualify as a sensible measure of fuzziness, function  $f$  must satisfy some requirements that adequately capture our intuitive comprehension of the degree of fuzziness (in this case, degree of belief). The following three requirements are essential:

1.  $f(A) = 0$  iff  $A$  is a crisp set;
2.  $f(A)$  attains its maximum iff  $A(x) = 0.5$  for  $x \in X$ , which is intuitively conceived as the highest fuzziness;
3.  $f(A) \leq f(B)$  when set  $A$  is undoubtedly sharper than set  $B$ , which according to our intuition, means that  $A(x) \leq B(x)$  when  $B(x) \leq 0.5$ , and  $A(x) \geq B(x)$  when  $B(x) \geq 0.5$ , for all  $x \in X$ .

The Hamming distance is defined by the sum of absolute values of differences. Choosing the Hamming distance, the local distinction (one for each  $x \in X$ ) of a given set  $A$  and its complement is measured by

$$|A(x) - (1 - A(x))| = |2A(x) - 1|, \quad [8]$$

and the lack of local distinction is measured by

$$1 - |2A(x) - 1| \tag{9}$$

The measure of fuzziness  $f(A)$  is then obtained by adding all local measurements:

$$f(A) = \sum_{x \in X} (1 - |2A(x) - 1|) \tag{10}$$

Stage 3.

In this stage an overall measure of uncertainty for the information received will be provided again based on the current state of information, as reflected in the persistent knowledge base and the uncertainty values. The entire model is illustrated in Figure 5. Mathematically this is represented as:

$$\text{Overall measure of uncertainty} = Q_i(T) = [(V_i) \circ (W_i) \circ (X_i)] \tag{11}$$

where  $\circ$  represents the enactment of an operation selected from a variety of operations for obtaining the measure of uncertainty. At this stage of the project the  $\circ$  has been used to represent the union (U), or max, of these fuzzy values.

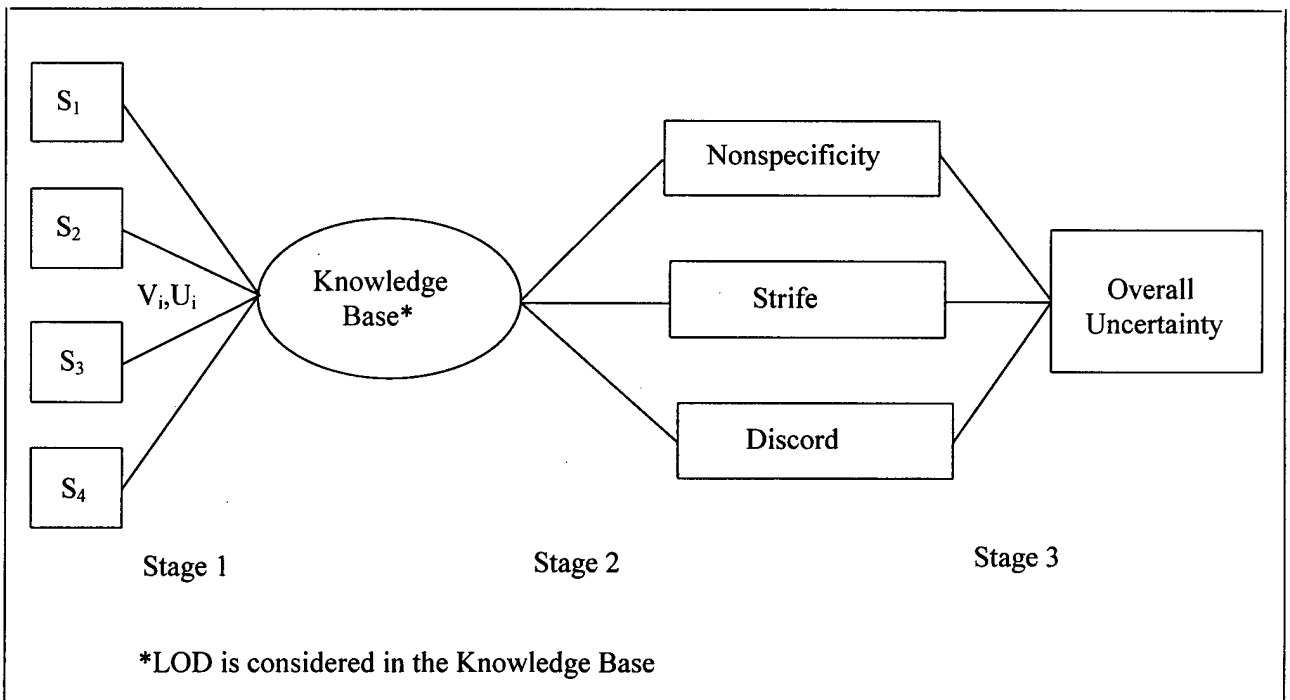

Figure 5. Three stages of the uncertainty model.

This overall measure of uncertainty will be a crisp output for use by the situation assessment modules in the detailed decomposition model in Figure 6. Figure 6 illustrates the developed model in conjunction with existing intelligent techniques used in modeling the combat environment. It should be noted that the situation assessment component of the model, though considered briefly in this case, is a highly complex environment and a variety of techniques are available to model situational awareness (Egan, 1990). This model does not attempt to fully represent the situational awareness aspects but rather will be complementary to an existing methodology for modeling situational awareness in the combat environment.

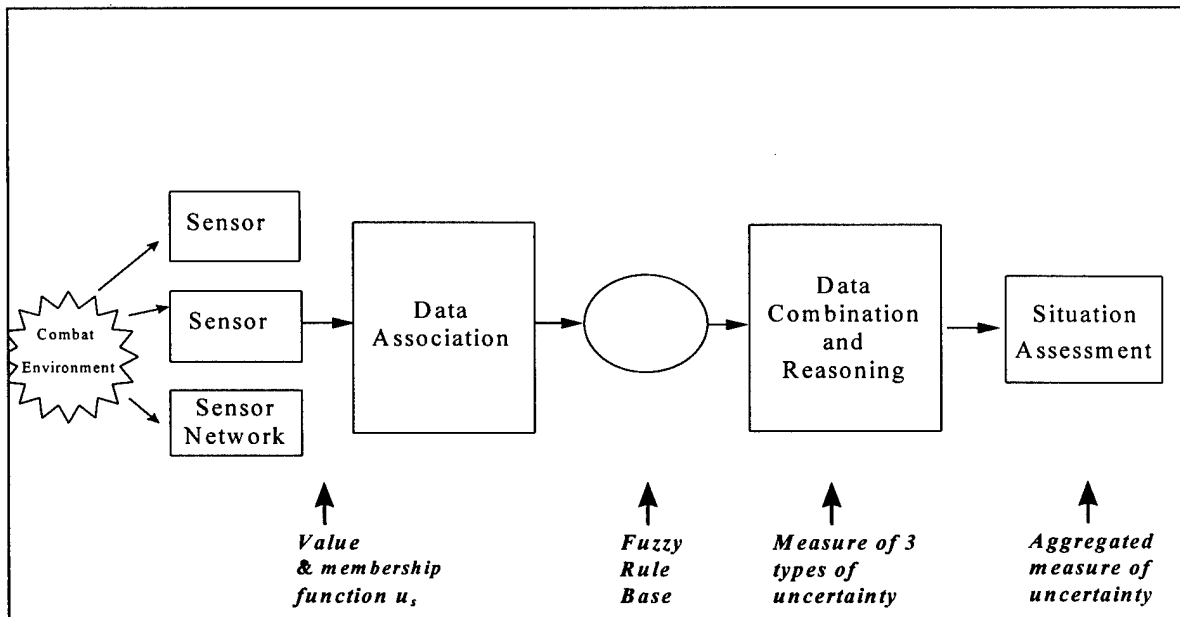

Figure 6. Detailed decomposition of Fuzzy Uncertainty Measurement Model.

#### Discussion

It is envisioned that the fuzzy uncertainty measure model will run in parallel with existing IW models and modules as shown in Figure 6. The fuzzy system will utilize the same data as the existing model. It will be processed off-line and then returned to the situation assessment and decision making models in a crisp output for their use. This type of model will

lend itself to reuse as it is not an embedded model and therefore can be used in other models as required.

The situational database, or persistent knowledge base, is envisioned as a theoretically omnipotent, holistic representation of the mission space. The aggregated values of information will be maintained here for comparison with new incoming pieces of information. The fuzzy rule base will be used to determine if the information piece content value meets the  $\alpha$ -cut off requirements of existing knowledge and whether it adds to the value of the overall information picture. The uncertainty of the information will be obtained by mathematically determining the value of the piece of information with respect to the overall information picture.

### INTELLIGENCE ANALYST EXAMPLE

One example of the application of the Fuzzy Logic Evidence Accrual Model can be seen in the activities of an Air Force intelligence analyst during a Joint Theater level campaign. The intelligence analyst monitors streams of data as they emerge from the theater of war in the naval, air, and ground arenas to assess the offensive and defensive picture for the Air Force's Tactical Air Warfare operations. Sources of information include intelligence, national sources, pre-flight intelligence, and tactical data links. Many types of sensors are employed. Targets of importance to the analyst are aircraft and missiles. Events in which these targets are involved include aircraft maneuvers, missile engagements, and electronic countermeasures (jamming).

An expert at the opposing force's tactical doctrine, the analyst has assembled a bird's eye view of the Theater of War complete with positioning of the forces and the battle plan for friendly forces. In response to each incoming new piece of information, the analyst must decide whether it requires reporting to the Joint Force Air Component Commander (JFACC), who controls the Air Warfare assets. Table 3 demonstrates the arrival and processing for each piece of information, as processed by the fuzzy logic model.

Table 3

*Example Analysis*

<b>Information Received</b>	<b>Processing</b>	<b>Uncertainty Measure</b>
Missile Engagement	Current report, from known target area, successfully destroyed opposing target of air-defense position	This information appears to have no uncertainty associated with it and does not appear to be in conflict with existing information
Troop Movement	Days old report, unknown source, small number of opposing force movement in area not previously targeted, north of current air operations area	Nonspecificity: moderate Discord/strife: moderate Fuzziness: moderate
IFF Report	Current report, small number of additional friendly force aircraft in current air operations area, no air operations order for such activity	Nonspecificity: moderate Discord/strife: high Fuzziness: moderate
Radar Report	Reliable source indicating small numbers of opposing force aircraft moving south of current air operations area	Nonspecificity: high Discord/strife: high Fuzziness: high
Visual Sighting	Civilian report sighting of large numbers of aircraft to the south of current air operations area	Nonspecificity: moderate Discord/strife: moderate Fuzziness: moderate
Airborne Surveillance Report	Timely and reliable report from AWACS plane indicating opposing force aircraft carrier task force moving south	Nonspecificity: low Discord/strife: low Fuzziness: moderate

The linguistic values are obtained by categorizing the ranges of the membership function. These linguistic values are obtained for the purpose of conveying the state of the system in layman's terms as well as being useful in the persistent knowledge base. To understand the numeric implications of this problem, Table 4 hypothetically assigns values for the uncertainty and significance of each input.

Table 4

*Stages of the Example Problem*

Information Received	Stage 1 (Value and Uncertainty of Information)	Stage 2 Three Fuzzy Measures Obtained	Stage 3 Overall Determination of Uncertainty Level
Missile Engagement	$(Y_1, \mu_1)$ where $Y_i$ - represents the <i>value</i> of the information conveyed by this sensor $\mu_1$ - represents the uncertainty associated with this sensor's information	$(V_1)$ - nonspecificity $(W_1)$ -discord/strife $(X_1)$ - fuzziness  Mathematical operations are performed as outlined in previous sections to obtain numeric value for each of these types of uncertainty	$Q_1(T) = [(V_1) \circ (W_1) \circ (X_1)]$  The operation is performed on the three measures of uncertainty to obtain an overall measure of uncertainty for the given sensor.
Troop Movement	$(Y_2, \mu_2)$	$(V_2)$ - nonspecificity $(W_2)$ -discord/strife $(X_2)$ - fuzziness	$Q_2(T) = [(V_2) \circ (W_2) \circ (X_2)]$
IFF Report	$(Y_3, \mu_3)$	$(V_3)$ - nonspecificity $(W_3)$ -discord/strife $(X_3)$ - fuzziness	$Q_3(T) = [(V_3) \circ (W_3) \circ (X_3)]$
Radar Report	$(Y_4, \mu_4)$	$(V_4)$ - nonspecificity $(W_4)$ -discord/strife $(X_4)$ - fuzziness	$Q_4(T) = [(V_4) \circ (W_4) \circ (X_4)]$
Visual Sighting	$(Y_5, \mu_5)$	$(V_5)$ - nonspecificity $(W_5)$ -discord/strife $(X_5)$ - fuzziness	$Q_5(T) = [(V_5) \circ (W_5) \circ (X_5)]$
Airborne Surveillance Report	$(Y_6, \mu_6)$	$(V_6)$ - nonspecificity $(W_6)$ -discord/strife $(X_6)$ - fuzziness	$Q_6(T) = [(V_6) \circ (W_6) \circ (X_6)]$

However, in order to categorize the results obtained in the mathematical equations detailed for the three levels of uncertainty, a quantitative to qualitative approach is needed. Thus, the quantitative values in Table 5 are used to assign a linguistic value to the numeric outputs. In order to aggregate the overall uncertainty of the system, a weighted sum of the individual sensors values,  $Y_i$ , times the overall uncertainty,  $Q_i(T)$ , is proposed.

Table 5

*Categorization of Crisp Outputs*

Range of Final Crisp Output	Linguistic Category
0.0 - .10	minimal
.11 - .30	low
.31 - .50	moderate
.51 - .70	high
> .71	very high

## CONCLUSION

This study demonstrates a first attempt at the incorporation of fuzzy set theory in evidence accrual. This model should be extended to a variety of environments and interwoven with existing techniques for management of uncertainty in this arena. The project was successful in analyzing and characterizing the factors which take place in evidence accrual through an evaluation of the first two phases of the OODA loop. While the model is theoretically sound, the absence of data for the purpose of fully evaluating the model minimized the ability to evaluate the methodology. Upon the availability of this data, the aggregation techniques and alternative aggregation approaches may be evaluated.

## REFERENCES

- Badiru, A.B. (1992). *Expert systems applications in engineering and manufacturing*. Englewood Cliffs, NJ: Prentice-Hall.
- Boyd, J. R. (1987). *A Discourse on Winning and Losing*.
- Cisneros, J. E., Karr, C. R., & McCauley-Bell, P. (1995). *Intelligent targeting in ModSAF* (Contract report IST-CR-95-36). Orlando: University of Central Florida, Institute for Simulation and Training.
- Cox, E. (1994). *The fuzzy systems handbook: A practitioner's guide to building, using, and maintaining fuzzy systems*. New York: Academic Press.
- Egan, S. T. (1990). *Non-sequential considerations in attaining situation awareness*. Baltimore, MD: Johns Hopkins University.
- Gupta, M., Knopf, G., & Nikiforuk, P. (1988). Sinusoidal-based cognitive mapping functions. In M. Gupta & T. Yamakawa (Eds.), *Fuzzy logic in knowledge-based systems, Decision and control* (pp. 69-92). Amsterdam: Elsevier Science Publishers.
- King, H. (1988). *An adaptive fuzzy logic control system*. Unpublished doctoral dissertation, Louisiana Tech University, Ruston.
- Klir, G., & Yuan, B. (1995). *Fuzzy sets and fuzzy logic: Theory and applications*. Upper Saddle River, NJ: Prentice-Hall.
- Llinas, J. (1996, February). *Fusion, Situational Awareness, and Information Warfare*. Paper presented at Armstrong Laboratory, Wright Patterson AFB, OH.
- Shafer, G. A. (1976). *A mathematical theory of evidence*. Princeton, NJ: Princeton University Press.
- Stein, G. J. (1995). Information warfare. *Airpower Journal*, IX (1), 31-39.
- Szafranski, R. (1995). A theory of information warfare. *Airpower Journal*, IX (1), 56-65.
- Waltz E. L., & Buede, D. M. (1986, November/December). Data fusion and decision support for command and control. *IEEE Transactions on Systems, Man, and Cybernetics*, Vol. SMC-16 (6), 865-879.
- Widnall, S. E., & Fogleman, R. R. (1995, October). Cornerstones of information warfare. Washington D.C.: Dept. of the Air Force.

Yager, R. R. (1980). On modeling interpersonal communication. In P. P Wang & K. S. Chang (Eds.), *Fuzzy sets: Theory and applications to policy analysis and information systems* (pp. 309-320). New York: Plenum Press.

APPENDIX  
OVERVIEW OF FUZZY SET THEORY

Numeric Basis of FST

A fuzzy set is a class of objects with a continuum of grades of membership defined for a given interval. Such a set is characterized by a membership function that assigns a degree of membership ranging between zero and one to each object. To understand the mathematical definition of fuzzy sets, consider a finite set of objects  $X$ .

- 1) Define the finite set as

$$X = x_1, x_2, \dots, x_n \quad [12]$$

where  $x_i$  are elements in the set  $X$ . Each element,  $x_i$ , has a particular membership value,  $\mu_i$ , which represents its grade of membership in a fuzzy set (Badiru, 1992). The set of membership values associated with the fuzzy set occur along the continuum  $[0,1]$ . A fuzzy set  $A$  can thus be represented as a linear combination of the following form:

$$A = \mu_1(x_1), \mu_2(x_2), \dots, \mu_n(x_n). \quad [13]$$

A fuzzy set could also be expressed as a vector, a table, or a standard function whose parameters can be adjusted to fit a given system. The interval over which a fuzzy set applies, known as a universe of discourse  $U$ , is thus characterized by a membership function which associates each element  $x_i$  of  $X$  with a degree of membership  $\mu_i$ .

- 2) The membership values,  $\mu_i$ , of each element in the fuzzy set  $A$  may be normalized such that they all are represented by values over a desired range. In fuzzy sets this typically means representing the potential outcomes of the elements over the interval  $[0,1]$ . A fuzzy set is considered 'normal' if the maximum value of the elements,  $\mu_i$ , is 1 and the minimum value  $\mu_i$  is 0.

### 3) Concentration

$$\mu_{con}(u) = (\mu_A(u))^2$$

### 4) Dilation

$$\mu_{dil}(u) = (\mu_A(u))^{1/2}$$

Based on the previous numerical basis for a fuzzy set, a graphical representation is created to further illustrate the progression of the set from one state to another.

To understand the mathematical definition of fuzzy sets, consider a set of objects A defined over a sample space X.

#### 1) Consider a finite set defined as

$$X = x_1, x_2, \dots, x_n \quad [14]$$

where the grade of membership of  $x_i$  in A is defined over the interval [0,1]. Each element will have a particular membership value  $\mu_i$  (Badiru, 1992). A membership function may be expressed as a vector, a table, or a standard function whose parameters can be adjusted to fit a given system. Given the membership values,  $\mu_i$ , the set A can be represented as a fuzzy set with the linear combination of the following:

$$A = \mu_1(x_1), \mu_2(x_2), \dots, \mu_n(x_n) \quad [15]$$

Thus, a fuzzy set A of a universe of discourse U, is characterized by a membership function which associates each element  $x_i$  of X with a degree of membership ( $\mu_i$ ). A fuzzy set A is considered as the union of its constituent singletons (King, 1988).

2) Normalization of a set simply means normalizing the values of the outcomes such that they are all represented over a desired range. In fuzzy sets this typically means representing the potential outcomes on the interval [0,1]. Thus, all potential

values of the set occur over the interval [0,1]. A fuzzy set A is normal if the maximum value of the membership function,  $\mu(x) = 1$ .

3) Two fuzzy sets are said to be equal if, and only if, for any x in U,

$$\mu_A(x) = \mu_B(x) \quad [16]$$

Fuzzy sets share many of the properties of conventional sets. Some of these properties that apply to fuzzy sets include the following (Badiru, 1992):

*Equality:*

$$A = B \text{ iff } \mu_A(x) = \mu_B(x), \forall x \in X \quad [17]$$

*Containment:*

$$A \subseteq B \text{ iff } \mu_A(x) \leq \mu_B(x), \forall x \in X \quad [18]$$

*Intersection:*

$$\mu_{A \cap B}(x) = \min_x [\mu_A(x), \mu_B(x)] \quad [19]$$

*Union:*

$$\mu_{A \cup B}(x) = \max_x [\mu_A(x), \mu_B(x)] \quad [20]$$

*Complement:*

$$\mu_{A^c}(x) = 1 - \mu_A(x) \quad [21]$$

These operations on fuzzy sets are very similar to standard sets. Other operation properties which hold for fuzzy sets include the commutative, distributive, associative, and idempotence properties, as well as De Morgan's Law.

*Commutative Property:*

$$A \cup B = B \cup A \quad [22]$$

$$A \cap B = B \cap A \quad [23]$$

*Distributive Property:*

$$A \cup (B \cap C) = (A \cup B) \cap (A \cup C) \quad [24]$$

$$A \cap (B \cup C) = (A \cap B) \cup (A \cap C) \quad [25]$$

*Associative Property:*

$$(A \cup B) \cup C = A \cup (B \cup C) \quad [26]$$

$$(A \cap B) \cap C = A \cap (B \cap C) \quad [27]$$

*Idempotence Property:*

$$A \cap A = A \quad [28]$$

$$A \cup A = A \quad [29]$$

*De Morgan's Law:*

$$\mu_{(A \cap B)^c}(x) = \mu_{(A^c \cup B^c)}(x) \quad [30]$$

$$\mu_{(A \cup B)^c}(x) = \mu_{(A^c \cap B^c)}(x). \quad [31]$$

These operations become very important when attempting to manipulate fuzzy sets, particularly when two or more sets are involved.

### Fuzziness vs. Probability

The proponents of fuzzy set theory must deal with a fundamental issue: with probability theory available to characterize uncertainty, what is the added utility of fuzzy set theory? Although randomness and fuzziness share many similarities, they have fundamental differences which set them apart. Both systems describe uncertainty with numbers in the unit interval [0,1]. Thus, both systems numerically represent uncertainty. Both systems also combine sets and propositions associatively, commutatively, and distributively.

A key distinction, however, is how the systems jointly treat a set A and its complement. Classical set theory states that the intersection of a set A and its complement  $A^C$  is the null set. This is represented as:

$$A \cap A^c = \emptyset \quad [32]$$

and by probability theory:

$$P(A \cap A^c) = P(\emptyset) = 0. \quad [33]$$

Fuzzy set theory, however, states that the intersection of a set A and its complement  $A^C$  can have events in common. This is represented as:

$$A \cap A^c \neq \emptyset. \quad [34]$$

For example, consider a fuzzy set  $A = \{1,2,3,4,5\}$ , which contains a set of numbers which are close to the number 5.

$$A: \{3/0.5, 4/0.8, 5/1\}.$$

Each element has a particular membership value which represents its grade of membership in the fuzzy set  $A$  (i.e., the membership grade of the number 3 is 0.5, of 4 is 0.8, and of 5 is 1). The

$$A^C: \{3/0.3, 2/0.5, 1/0.7\}.$$

complement of  $A$ ,  $A^C$ , contains a set of numbers which are not close to 5.

In traditional set theory the numbers 3, 4, and 5 could not be a member of the set  $A^C$  since they are in the set  $A$ . Note, however, that in the above example both sets  $A$  and  $A^C$  contain the number 3. The number 3 belongs to the set  $A$  with a membership grade of 0.5 and to the set  $A^C$  with a membership grade of 0.3. Thus, there is a distinct difference in what the numeric values for fuzzy sets and probabilistic sets are capable of representing.

In order to understand fuzziness as an alternative to randomness for describing uncertainty, consider the following. Fuzziness describes *event ambiguity*. It measures the degree to which an event occurs, *not* whether it occurs. Randomness, on the other hand, describes the uncertainty of *event occurrence*. Thus, whether or not an event occurs is “randomness” and the degree to which it occurs is “fuzziness.” For example, the uncertainty associated with the outcome for a roll of a die has a certain probability associated with it. This event does not represent ambiguity but rather uncertainty of event occurrence. Once the die is rolled the need for the probability due to the lack of knowledge concerning the future outcome dissipates. Now consider the term *tall* when used to describe the height of a man. The ambiguity associated with this event lies in differentiating where tall begins and ends - -or *the degree to which the person is tall*. This type of ambiguity is characteristic of fuzziness because there does not exist a specific height at which we consider a person to be tall or not tall. Instead there is a progression which is more appropriately represented by linguistic terms (i.e. tall, somewhat tall, not tall). Thus, in contrast to the probabilistic representation of uncertainty, no addition of information is useful in

removing the ambiguity associated with the boundaries for describing the variables tall and not tall. It is in such situations that the concept of fuzziness becomes useful.

### Mapping Functions

Not all phenomenon can be represented by fuzzy sets. In ordinary (i.e., crisp) subsets, a phenomenon is represented by a characteristic function. The characteristic function is associated with a set, S, which is represented as a binary mapping function

$$\mu_s : X \rightarrow [0,1]$$

such that for any element x in the universe,  $\mu_s(x) = 1$  if x is a member of S and  $\mu_s(x) = 0$  if x is not a member of S.

In order to be 'fuzzified', the real world characteristics of a phenomenon must be able to be mapped to a fuzzy mapping function. The goal of this function is to map a subjective and ambiguous real world phenomenon, X, into a membership domain, for example, [0,1]. This mapping function is a graphical representation of an element as it passes throughout a continuous (i.e., non-binary) set of potential membership values. In other words, the mapping function provides a means to view the progression of the changes in the state of a given variable. Thus, this representation is referred to as a *membership function* for the fuzzy set. The term "membership function" emphasizes the previously stated premise of fuzzy sets: for a fuzzy set A, each x value within the set has an associated  $\mu(x)$  value that indicates the degree to which x is a member of the set A.

Membership functions are a characteristic of the data set under analysis and can take on many forms. Several geometric mapping functions have been developed, including S,  $\pi$ , trapezoidal, and triangular shaped functions. All of these functions have utility in characterizing the environments of particular systems and could fill the remaining chapters in this book (Cox, 1994). Sinusoidal mapping functions, which include the S and  $\pi$  shapes (Gupta et al, 1988), are the most frequently implemented. They are thus the functions focused on in this review. These two particular classes of sinusoidal functions are discussed below.

For all S and  $\pi$  mapping functions discussed below, consider the fuzzy phenomenon X, defined over a real (i.e., non-negative) interval  $[x_m, x_M]$ , where  $x_m$  and  $x_M$  correspond to the lower and upper bounds of the set X, respectively.

*S (sigmoid/logistic) mapping functions.*

These mapping functions are termed “S” because they are shaped much like the letter S. The curves that comprise the S Mapping functions may be referred to as **growth** and **decline** curves (Cox, 1994). The growth S-curve set moves from no membership at its extreme left-hand side, to complete membership at its extreme right hand side. The decline S-Curve behaves in just the opposite manner, beginning with complete membership at its extreme left-hand side, and progressing to zero membership at it’s extreme right hand side.

There are three types of S mapping functions:  $S_1$ ,  $S_2$ , and  $S_3$ . Each of these functions has utility in the representation of fuzzy elements.

$S_1$  Mapping Functions. The mapping function  $S_1$  maps  $x_i$  ( $x_m \leq x_i \leq x_M$ ) into a non-symmetric sinusoidal membership function.

$S_2$  Mapping Functions. For the  $S_2$  sinusoidal mapping function a symmetrical crossover point  $x_c$  is defined as follows:

$$x_c = 1/(x_m + x_M) \quad [35]$$

The mapping function  $S_2$  assigns low fuzzy set membership values to points below the crossover point [ $x_i \leq x_c$ ; i.e.,  $0.0 \leq x_i \leq 0.5$ ] and higher membership values to points above the crossover point [ $x_i \geq x_c$ ; i.e.,  $0.5 \leq x_i \leq 1.0$ ].

*$\pi$  mapping functions.*

The  $\pi$  mapping functions are so named because they approximately simulate the shape of the Greek letter  $\pi$ . For this mapping function, the symmetrical point  $x_S$  is defined as the mid-point of the interval  $[x_m, x_M]$ ,

$$x_s = 1/(x_m + x_M) \quad [36]$$

and the lower and upper crossover points are both defined as:

$$x_{c1} = 1/(x_m + x_s) \quad [37]$$

The  $\pi$  mapping function is a convex function which increases monotonically from 0 to 1 over the interval  $[x_m, x_s]$  and decreases monotonically from 1 to 0 over the interval  $[x_s, x_M]$ . At the crossover points,  $x_{c1}$  and  $x_{c2}$ , the value of the function is 0.5.

The  $\pi$  shaped mapping function is the preferred and generally the default method of representing a fuzzy variable (Cox, 1994). This is because this method of representation allows a gradual descent from complete membership for a number in both directions, thus representing the concept of approximation. The symmetric  $\pi$  curve is centered on a single value and as the curve moves away from the ideal value (value with complete membership), the degrees of membership begin to taper off until the curve reaches a point of no membership, where  $\mu_s = 0$ .

#### *Linear membership functions.*

In cases where the universe of discourse  $X$  is a real line, the fuzzy set can be expressed as a line or as some functional form. Two primary types of linear membership functions include the triangular and trapezoidal membership functions. The linear membership function is perhaps the simplest membership function and is often used as a starting point when initially constructing membership functions. The construction of this curve often leads to more sophisticated linear membership functions and even to non-linear membership functions. Triangular shaped membership functions are used to represent relationships that are expected to be linear with a suspected optimal point or value and symmetry about this optimal point. This membership function is constructed under the same premise as the  $\pi$  shaped membership function: as the value moves bilaterally away from the suspected optimal point, the degrees of membership begin to decrease until the value of no membership ( $\mu_s = 0$ ) is reached at each end of the function.

As with the triangular shaped membership functions, the trapezoidal membership function is used to represent a set that is expected to exhibit a linear relationship. In this instance, there is not an optimal point or value which has complete membership. Rather, there is a range of values which have complete membership in the set. Fuzzy sets may also take on a combination of triangular and trapezoidal membership functions. For instance, in process control systems variables are decomposed into overlapping arrays of triangular shaped membership functions. The endpoints of these variables represent regions that begin and end in complete membership for a given set. These outer membership functions are often expressed as “shouldered” sets (Cox, 1994) and they appear as bisected trapezoids.

The development of an appropriate membership function is critical for effective representation and modeling of a fuzzy set. It is generally possible to represent virtually any domain through a membership function because such functions may take on a variety of different shapes and forms to accommodate a given data set. Irregular and unique shaped membership functions can also be developed to represent a fuzzy set in unusual cases. The previously mentioned membership functions, however, will be useful at graphically representing most fuzzy sets.

## GLOSSARY

ATO	Air Tasking Order
ECM	Electronic Countermeasures
IW	Information Warfare
JFACC	Joint Force Air Component Commander
LOD	Likelihood of Deceptibility
MAP	Maximum A Posteriori
OODA	Observe-Orient-Decide-Act