

# Behavioral Responses and Temporary Shift in Masked Hearing Threshold of Bottlenose Dolphins, *Tursiops truncatus*, to 1-second Tones of 141 to 201 dB re 1 $\mu$ Pa



Sam H. Ridgway  
Donald A. Carder  
Robert R. Smith  
Tricia Kamolnick  
Carolyn E. Schlundt  
Wesley R. Elsberry

19970728 181

DTIC QUALITY INSPECTED 4



NCCOSC • RDT&F Division D3503 • 49620 Beluga Road • San Diego, CA 92152-6266

**DISTRIBUTION STATEMENT A**

Approved for public release;  
Distribution Unlimited

Technical Report 1751

July 1997

**Behavioral Responses and  
Temporary Shift in Masked  
Hearing Threshold of Bottlenose  
Dolphins, *Tursiops truncatus*, to  
1-second Tones of 141 to 201 dB  
re 1  $\mu$ Pa**

Sam H. Ridgway, Donald A. Carder, Robert R. Smith, Tricia Kamolnick,  
Carolyn E. Schlundt, and Wesley R. Elsberry

**NAVAL COMMAND, CONTROL AND  
OCEAN SURVEILLANCE CENTER  
RDT&E DIVISION  
San Diego, California 92152-5001**

---

H. A. WILLIAMS, CAPT, USN  
Commanding Officer

R. C. KOLB  
Executive Director

**ADMINISTRATIVE INFORMATION**

*“Porpoises are peculiarly sensitive to the waves that are transmitted by the sonic depth finder and will disappear in great haste and apparent discomfort from the vicinity of a vessel when one of these contrivances is put in operation.”\**

The Navy is concerned that acoustic energy emissions from various products may interfere with marine mammals. Proposed federal regulations under the Marine Mammal Protection Act discuss temporary threshold shift (TTS) as a means of evaluating impacts of those emissions. Existing Navy methods published in the *Journal of the Acoustical Society of America* were applied to investigate TTS in the hearing sensitivity of bottlenose dolphins (*Tursiops truncatus*). Changes in the dolphins' behavior were observed at sound levels equal to or greater than 178 dB for 1-second tones at 3, 20, and 75 kHz. TTS was observed at sound levels equal to or greater than 192 dB for the three frequencies. These data provide a scientific basis for decisions concerning acoustic effects on marine mammals for use in preparation of environmental plans and mitigation strategies.

Funding was provided by the Office of Naval Research and the Program Executive Office Undersea Warfare.

Released by  
S. H. Ridgway, D.V.M., Ph.D.  
Senior Scientist for Animal Care and  
Research

Under authority of  
J. E. Haun, Head  
Bioscience Division

---

\*Howell, A. B. 1930. *Aquatic Mammals*. Charles Thomas, Springfield, IL.

## EXECUTIVE SUMMARY

The Navy is concerned with stewardship of natural resources while continuing to advance mission requirements. In undersea warfare activities, acoustic energy emissions from various products may interfere with marine mammals. Proposed federal regulations discuss temporary threshold shift (TTS) of hearing sensitivity as a means of evaluating impacts to marine mammals. These proposed regulations are not quantified, however, because prior to this project, essentially no supporting data were available on TTS in marine mammals.\*† Recognizing the growing concern for marine mammal protection relative to generated sound in the ocean, the Naval Command, Control and Ocean Surveillance Center RDT&E Division (NRaD) proposed to apply existing Navy expertise, technology, and methods published in the *Journal of the Acoustical Society of America* to investigate the potential for TTS for three frequencies: 3, 20, and 75 kHz. The project was initiated under the sponsorship of Program Executive Officer for Undersea Warfare (PEO(USW)) and Naval Air Systems Command (NAVAIR) with the expectation that knowledge gained in the TTS project would provide solid science on which to base environmental assessments required under the National Environmental Policy Act.

Dolphins depend upon sound to assess their environment, find food, and communicate among themselves. The hearing systems and frequencies used by bottlenose dolphins, *Tursiops truncatus*, are representative of several species of toothed whales. Computer-controlled methods developed at NRaD were applied to behavioral testing of hearing in the dolphins for TTS at the NRaD facility. Testing procedures were established in compliance with federal regulations concerning animal care and research. Changes in behavior were observed at the following minimum levels for 1-second tones: 186 dB @ 3 kHz, 181 dB @ 20 kHz, and 178 dB @ 75 kHz. TTS levels were 194 to 201 dB @ 3 kHz, 193 to 196 dB @ 20 kHz, and 192 to 194 dB @ 75 kHz. With these test results, there are now scientific data for decisions concerning acoustic effects on marine mammals for use in preparation of environmental plans and mitigation strategies.

---

\*Green, D. M., H. A. DeFerrari, D. McFadden, I. S. Pearse, A. N. Popper, W. J. Richardson, S. H. Ridgway and P. L. Tyack. 1994. *Low Frequency Sound and Marine Mammals: Current Knowledge and Research Needs*. 75 pp. National Academy Press, Washington, D.C.

†Richardson, W. J., C. R. Greene Jr., C. E. Malme and D. H. Thomson. 1995. *Marine Mammals and Noise*. Academic Press, Inc., San Diego, CA.

# CONTENTS

<b>EXECUTIVE SUMMARY</b> .....	<b>i</b>
<b>INTRODUCTION</b> .....	<b>1</b>
PURPOSE .....	1
BACKGROUND .....	1
<b>OBJECTIVES AND PROCEDURES</b> .....	<b>4</b>
STATEMENT OF OBJECTIVES .....	4
ANIMALS, TEST PROCEDURES, AND EQUIPMENT.....	4
Animals .....	4
Test Procedures.....	4
Equipment .....	9
<b>STUDY RESULTS</b> .....	<b>11</b>
BEHAVIORAL OBSERVATIONS.....	12
<b>IMPACTS ON MARINE MAMMALS</b> .....	<b>13</b>
<b>CONCLUSIONS</b> .....	<b>16</b>
<b>FUTURE STUDIES</b> .....	<b>16</b>
<b>ACKNOWLEDGMENTS</b> .....	<b>16</b>

## Tables

1. Pareto display of PEO(USW)/NAVAIR/MRTFB system data. ....	3
2. Animal, gender, measurements, and age. ....	4
3. S1 frequency, masking noise band, masking noise amplitude, and S2 hearing test frequencies. ....	6
4. Thresholds for observed altered behavior after louder S1s without TTS. ....	12
5. Thresholds, behavioral observations, and statistics for TTS to louder S1s. ....	14
6. Hypothetical calculation of safe distances in meters for a starting point for behavioral alteration and for TTS at 3 kHz only using five different source levels and three different propagation loss models. ....	15

## Figures

1.	Representative underwater audiograms for an odontocete (beluga), phocid (harbor seal), and otariid (northern fur seal). .....	2
2.	Human and dolphin auditory thresholds. ....	2
3.	Diagram of the TTS testing enclosure. ....	5
4.	Image of the computer screen during hearing threshold testing. ....	7
5.	Image of the computer screen during response editing. ....	7
6.	Image of computer screen during threshold determination analysis. ....	8
7.	Louder S1 signal of 192 dB presented to dolphin NEM that produced TTS. ....	8
8.	Diagram of computer program (BREAC) used for data collection and analysis. ....	9
9.	Schematic chart showing equipment setup for the hearing tests. ....	10
10a.	Dolphin horizontal received beam pattern. ....	13
10b.	Dolphin vertical received beam pattern. ....	13

## Appendices

A:	Equipment Used in the TTS Study and Calibration Graphs). ....	A-1
	A-1: AN/SSQ-62B Projector voltage source level response. ....	A-2
	A-2: ITC-1001 Projector voltage source level response. ....	A-2
	A-3: ITC-1042 Projector voltage source level response. ....	A-2
	A-4: X-Y Directivity pattern vs. frequency ITC-1042. ....	A-2
	A-5: Edo-Western 6166 Projector voltage source level response. ....	A-3
	A-6: J-9 Projector voltage source level response. ....	A-3
	A-7: Bruel & Kjaer 8103 Hydrophone receive sensitivity response. ....	A-4
	A-8: Bruel & Kjaer 2635 Charge amplifier frequency response. ....	A-4
	A-9: Crown Macro-Tech 2400 power amplifier frequency response curve. ....	A-5
B:	Raw Data for TTS to Louder S1s. ....	B-1

# INTRODUCTION

## PURPOSE

Temporary threshold shift (TTS) is a method of determining when the level of sound input temporarily reduces the ear's ability to respond fully. TTS is defined as a reversible decrease in hearing sensitivity as a result, for example, of exposure to loud noise.<sup>1</sup> The purpose of this study was to determine if TTS occurs in marine mammals as a result of acoustic energy emitted by tonal sources similar to those employed by Program Executive Officer for Undersea Warfare (PEO(USW)), Naval Air Systems Command (NAVAIR), and NAVAIR-oriented Major Range Test Facility Base (MRTFB) products and, if so, to specify the amplitude levels at which TTS occurs.

## BACKGROUND

The National Environmental Policy Act (NEPA) of 1969 requires all government actions to be evaluated for potential environmental impacts. The Department of the Navy, in response to this requirement as well as other environmental concerns, is taking the first steps to determine the impact of acoustic energy on marine mammals.

NEPA requires use of actual data when assessing environmental effects of an action. Previously, the lack of hard data on the impact of acoustic energy emissions on marine mammals was replaced by somewhat subjective evaluations by reputable scientists of the potential impact of a test on the marine environment. For those areas where there are insufficient data, the Navy decided to either develop and accumulate the data or demonstrate that it is of a prohibitive cost.

Additionally, the National Marine Fisheries Service (NMFS) is currently in the process of developing regulations on the harassment of marine mammals under the Marine Mammal Protection Act (MMPA) to address acoustic effects. The formal Navy response to the NMFS Notice of Proposed Rulemaking concerning marine mammal harassment proposed the use of TTS as the metric for determining harassment.

Given the absence of TTS data for marine mammals prior to this study, PEO(USW) coordinated Navy-wide meetings to determine the best course of action for collecting TTS information. Participants were representatives of: PEO(USW), Chief of Naval Operations, Office of Naval Research (ONR), NAVAIR, Space and Naval Warfare Systems Command (SPAWAR), Naval Command, Control and Ocean Surveillance Center Research, Development, Test and Evaluation Division (NRaD), and numerous test ranges (i.e., Atlantic Undersea Test and Evaluation Center, Atlantic Fleet Weapons Test Facility, Naval Undersea Warfare Center Keyport and Newport). In the Navy meetings, three primary issues associated with gathering data/information in a TTS study were: (a) locations and frequencies of acoustic energy activity, (b) animals affected, and (c) availability of assets for accomplishing the TTS study.

a. With respect to locations and frequencies of acoustic energy activity, program environmental documents discuss in detail the physical circumstances at the sites and the frequencies of acoustic emissions.

b. With respect to animals affected, the NRaD scientists compiled data in figures 1 and 2 which describe the auditory capabilities of various prevalent marine mammals. The marine

---

1. Green, D. M. 1976. *An Introduction to Hearing*. Lawrence Erlbaum Associates, Hillsdale, NJ.

mammal species potentially usable in a study of TTS is limited by the availability of marine mammal species under human care at research facilities and oceanaria. Figures 1 and 2 show that bottlenose dolphins, *Tursiops truncatus*, are good representatives of the marine mammals that have the potential of being affected by the selected frequencies because hearing range and sensitivity are equivalent to or broader than many marine mammals. At the frequencies tested in this study, especially the higher two frequencies, this dolphin species is rivaled in hearing

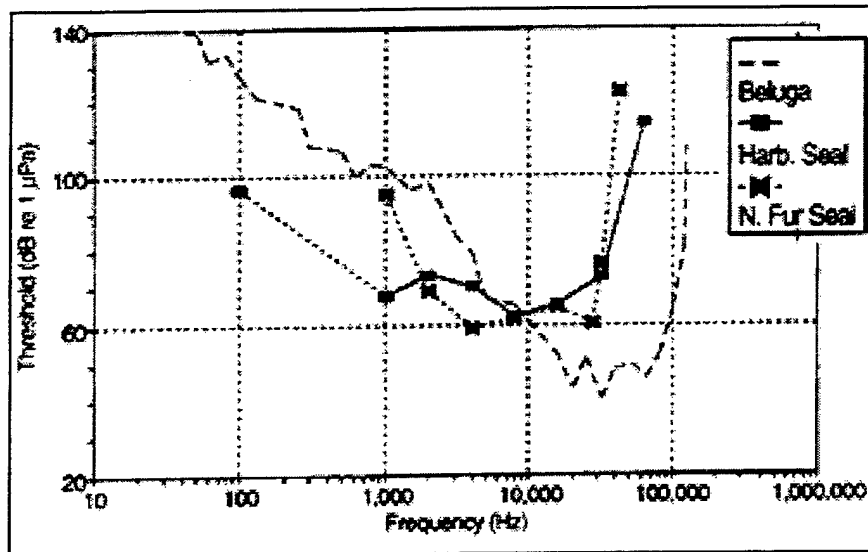

Figure 1: Representative underwater audiograms for an odontocete (beluga), phocid (harbor seal), and otariid (northern fur seal). (Adapted from: Richardson, W. J., C. I. Malme. 1995. "Zones of Noise Influence." In: *Marine Mammals and Noise* (W. J. Richardson, C. R. Greene Jr., C. I. Malme, and D. H. Thompson, Eds.), Academic Press, San Diego, CA.)

sensitivity only by its close relatives in the family Delphinidae. In addition, bottlenose dolphins have an around the world distribution in temperate and tropical waters. Their distribution extends as far south as the southernmost island of New Zealand and as far north as northernmost Norway, overlapping a very high percentage of Navy worldwide operating area. Because not all dolphin species are available to test, data can be extrapolated for non-tested species.

c. With respect to the availability of assets capable of accomplishing the TTS study, the NRaD facility has bottlenose dolphins that have been and are currently involved in RDT&E in accordance with applicable federal regulations.

NRaD also has the expertise in underwater hearing assessment and underwater acoustics hardware. Additionally, NRaD scientists have

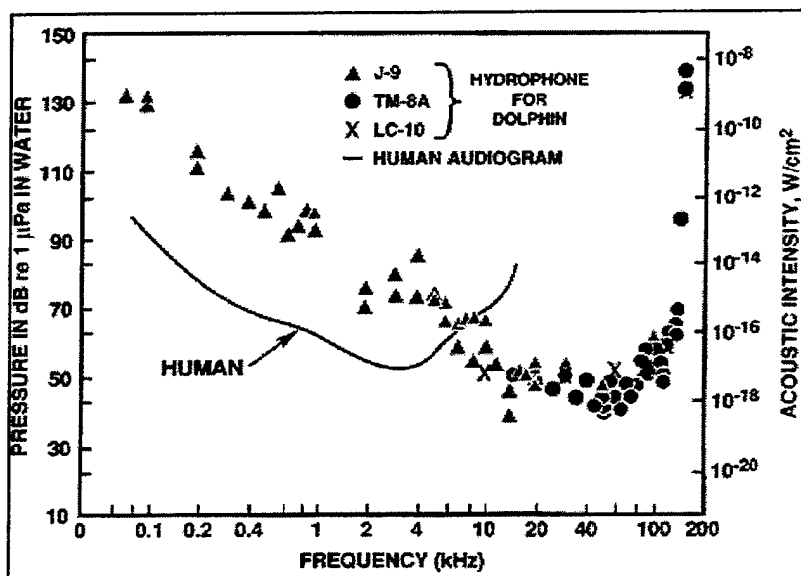

Figure 2: Human and dolphin auditory thresholds. (From: Johnson, C. S. 1966. "Auditory Thresholds of the Bottlenosed Porpoise (*Tursiops truncatus*)," NOTS TP 4178. U.S. Naval Ordnance Test Station, China Lake.)

developed testing procedures applicable for this study that are well known and accepted by the professional acoustics research community.<sup>2,3,4</sup> NRaD became the test site of choice by acclamation of all organizations represented at the TTS meetings.

Representatives of PEO(USW), NAVAIR, and MRTFB facilities provided data characterizing the acoustic signals of their systems. This information included frequencies, duration and duty cycle, amplitude, and bandwidths. Given the details of the systems and restricted funding, NRaD recommended testing for TTS at the three most common frequencies: 3, 20, and 75 kHz (table 1) and assessing associated frequencies within the octaves (i.e., 3 (4.5, 6); 20 (30, 40); and 75 (85, 100)). These frequencies provided a representative sample and covered frequency ranges for most systems, based on existing knowledge of dolphin hearing range.<sup>2</sup>

To manage the study effort, PEO(USW) established a TTS steering group comprised of representatives from PEO(USW), NAVAIR, ONR, and MRTFB. This initial TTS study addressed the three frequencies that NRaD recommended and was scheduled to take 6 to 7 months to complete. Normal progress was assessed by the Steering Group via monthly video teleconferences with principal investigators at NRaD.

The development of TTS data will not only help the Navy to assess the potential for environmental impact of acoustic energy, it will also provide a more systematic approach to acoustic studies across the Navy. The results and data of this study will be published in peer-reviewed journals, such as the *Journal of the Acoustical Society of America (JASA)*. TTS data will likely become widely accepted within the professional acoustics community as a quantitative basis for assessing the potential impact of acoustic energy on marine mammals.

Table 1. Pareto display of PEO(USW)/NAVAIR/MRTFB system data.

Number of Systems	Frequency (kHz)
3	90
8	*75
3	60
4	40
10	*20
6	10
7	* 3
7	1.25/1.5

\*Frequencies chosen for the current tests

2. Au, W. W. L. 1993. *The Sonar of Dolphins*. Springer-Verlag, New York, NY.  
 3. Ridgway, S. H. and D. A. Carder. 1997. "Hearing Deficits Measured in Some *Tursiops truncatus*, and Discovery of a Deaf/Mute Dolphin." *Journal of the Acoustical Society of America* 101:590-593.  
 4. Schusterman, R. 1980. "Behavioral Methodology in Echolocation by Marine Mammals." In *Animal Sonar Systems*. R. G. Busnel and J. Fish, Eds. Plenum Press, New York, NY.

## OBJECTIVES AND PROCEDURES

### STATEMENT OF OBJECTIVES

The objective of the study was to formulate criteria based on TTS for safe levels of underwater sound for dolphins at the three selected frequencies.

Deliverables included:

- 1) a frequency-by-frequency and source level-by-source level evaluation of the likelihood of TTS production in the three selected frequency ranges;
- 2) a listing of any behavioral observations that presage or occur along with TTS; and,
- 3) an assessment of other signals that may or may not require future TTS evaluation.

To allow the broadest distribution of scientific and technical results from this study, classified information on the performance of specific acoustic devices is not included in this report.

### ANIMALS, TEST PROCEDURES, AND EQUIPMENT

#### Animals

At NRaD, scientists developed computer-controlled methods for behavioral testing of hearing in marine mammals. The animals employed in these tests and their gender, measurements, and age are listed in table 2.

Table 2. Animal, gender, measurements, and age.

Animal	Gender	Weight (kg)	Length (cm)	Age (yrs)
NEM	M	227	271	32
APR	F	150	240	13
MUU	F	176	244	20
TOD	F	250	271	39

#### Test Procedures

The test design used existing Navy animals, equipment, methods, expertise, and technology. The diagram of the TTS testing enclosure is shown in figure 3. Methods for TTS determination involved training animals to listen for a 1-second (s) "start" signal (S1) at one listening station (S1 station) that cued them to proceed to a second listening station (S2 station) for hearing testing. The S1 signal for baseline hearing testing was set at 141 dB re 1 $\mu$ Pa because the range of amplitudes for dolphin whistles recorded previously was 103 to 179 dB. The chosen amplitude was the median of this range. The S1 signal was chosen to be 1 s because that is a typical duration of the signals of interest. Next, the animals were trained to respond by whistling when they heard "hearing" test tones (S2 tones). Intensity level was varied in a staircase procedure until a threshold was determined. Threshold was identified as the sound pressure level average of the five lowest responses in response-no response reversals. The duration of the S2 test tones was set at 0.25 s or 250 milliseconds (ms) because previous studies on bottlenose dolphins<sup>5</sup> had revealed that this duration is sufficient to obtain stable hearing thresholds.

5. Johnson, C. S. 1968. "Relation Between Absolute Threshold and Duration-of-Tone Pulses in the Bottlenosed Porpoise." *Journal of the Acoustical Society of America* 43: 757-763.

The **FIRST PHASE** of testing consisted of determining a pre-test baseline noise-limited hearing threshold (BNHT). Random masking noise just above the average ambient peaks in the San Diego Bay noise levels was used (table 3) because a noise-free test environment was not possible. When the noise level in the bay, as monitored through hydrophone E (see figure 3), exceeded the masking noise, testing was stopped until ambient noise levels again fell below the controlled masking noise. At 3 kHz, repeated measurements of background noise recorded at the S2 station demonstrated that 90 dB of masking noise (table 3) was sufficient most of the time. However, when certain vessels such as tug boats approached the area, background noise levels exceeded the masking and testing stopped. For testing in the 20 to 100-kHz range, masking noise had to be increased to 100 dB to compensate for high-frequency sounds, especially from other dolphins in adjacent enclosures.

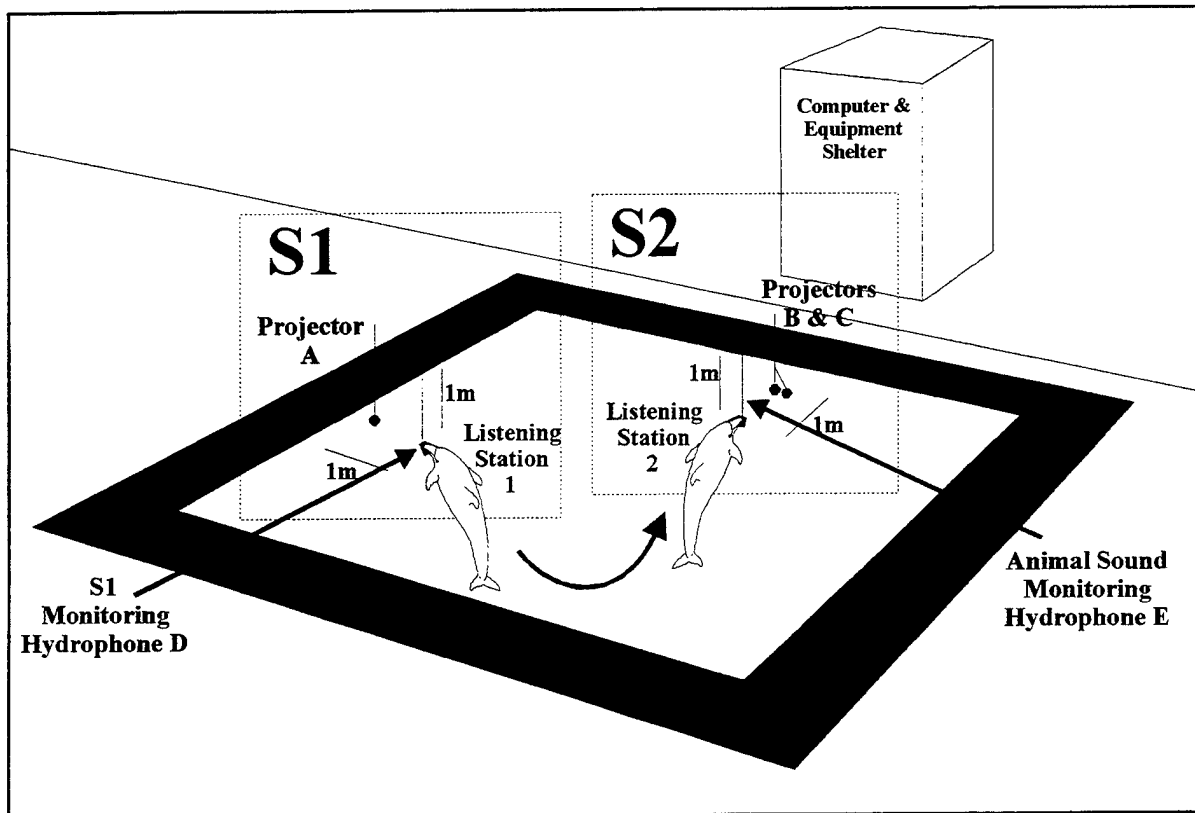

Figure 3. Diagram of the TTS testing enclosure. At listening station 1, the dolphin got an S1 signal from projector A, then proceeded to listening station 2 for hearing threshold testing. Projector B delivered the S2 tones and projector C emitted the white noise that served as level background. Monitoring hydrophone D was used to record louder S1 signals for precise determination of acoustic amplitude at the dolphin's lower jaw. Monitoring hydrophone E recorded the dolphin whistles that were emitted by the animal when it heard an S2 tone.

BNHTs were determined at the three base frequencies (3 kHz, 20 kHz, and 75 kHz) used as the S1 signal (table 1) as well as two higher frequencies within the octave above the S1 signal (see table 3). The use of multiple frequencies for hearing tests was based on human research showing that TTS often occurs at frequencies above the S1 frequency.<sup>1,6</sup>

Table 3. S1 frequency, masking noise band, masking noise amplitude, and S2 hearing test frequencies.

Base and S1 Frequency (kHz)	Masking Noise Band (kHz)/ Amplitude (dB)	S2 Hearing Frequencies (kHz)
3	1-11/90	3, 4.5, 6
20	10-50/100	20, 30, 40
75	60-110/100	75, 85, 100

A **TRIAL BLOCK** began with the dolphin in front of the trainer. At the trainer's hand signal, the dolphin swam to the S1 station where it received the S1 signal. The S1 signals were tones of 1-s duration and constant amplitude of 141 dB re 1  $\mu$ Pa at 1 m during the first phase of testing. When the S1 signal ended, the dolphin swam to the S2 station for hearing test tones delivered at randomized intervals over a 1 to 3 minute period. The dolphin remained on the S2 station for 20 to 30 hearing test tones. The dolphin was trained to whistle whenever it heard an S2 tone. If the dolphin whistled after a test tone (S2), the loudness of the next S2 tone was progressively reduced by 2- to 4-dB steps until the dolphin failed to make a whistle response. When the dolphin did not respond, the next test tone (S2) was made 2 dB louder than the previous tone (S2) until a response was received. This procedure is sometimes referred to as a "staircase" method for determining psychophysical thresholds such as hearing thresholds.<sup>2</sup>

The S1 and S2 tones were generated and recorded by specially designed software (see figures 4, 5, 6, and 9). Dolphin response whistles were recorded by the same program, and analyzed later to determine thresholds (figures 5 & 6). Because response latency has been correlated with perceived loudness in previous experiments,<sup>7,8</sup> these data were recorded for possible analysis of a "subjective loudness scale" to be correlated with TTS or other behavioral and physiological indications of response to loud sound. However, that analysis is beyond the scope of the original test plan and is not included in this report.

It took approximately 1 month to obtain stable pre-test noise-limited baseline hearing thresholds at each of the three S2 frequencies, using a low-level S1 start signal at a 1-s duration and constant amplitude of 141 dB re 1  $\mu$ Pa at 1 m.

The **SECOND PHASE** began during the second month of testing. In this phase, a louder S1 signal (figure 7) of the same duration was inserted in one of the 10 trial blocks on a semi-random schedule that caused the louder S1 signal to occur most often in the fourth through seventh trial block (providing a "warm-up and "cool-down" of baseline conditions before and after the louder S1 test condition, each day). For the first test series of 20 kHz, the louder S1 was raised each day by an increment of 6 dB over the preceding day until the S2 threshold was ele-

6. Dancer, A. L., D. Henderson, R. J. Salvi, and R. P. Hamernik, Eds. 1992. *Noise-Induced Hearing Loss*. Mosby Year Book, St. Louis, MD.
7. Ridgway, S. H., D. A. Carder, P. L. Kamolnick, D. J. Skaar and W. A. Root. 1991. "Acoustic Response Times (RTs) for *Tursiops truncatus*." *Journal of the Acoustical Society of America* 89:1967-1968.
8. Stebbins, W. C. 1970. *Animal Psychophysics: The Design and Conduct of Sensory Experiments*. Appleton-Century-Crofts, New York, NY.

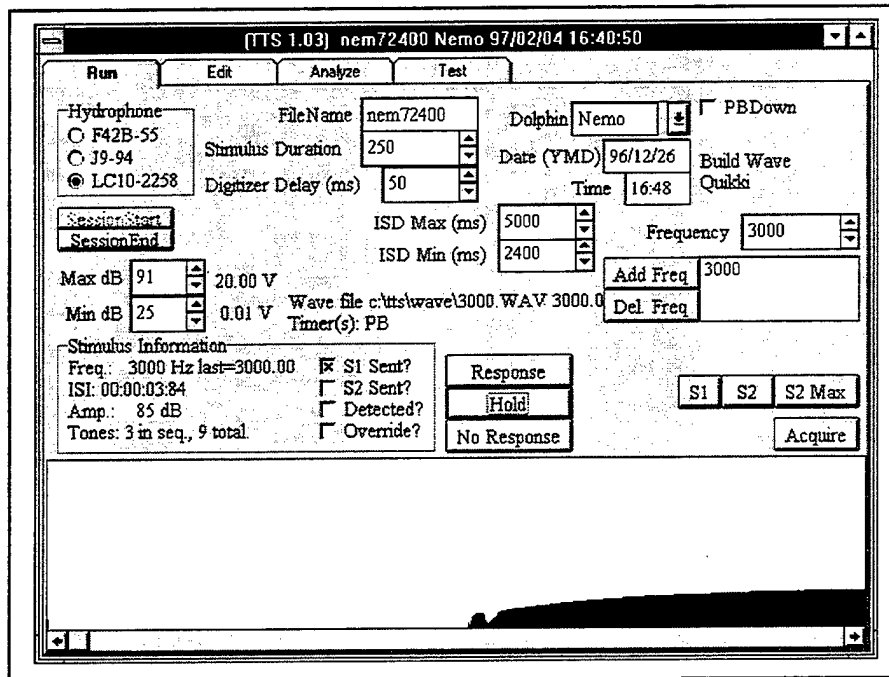

Figure 4. Image of the computer screen during hearing threshold testing. Also, see figure 8 for a diagram showing relationships within the BREAC program from which figures 4, 5, and 6 are pictured.

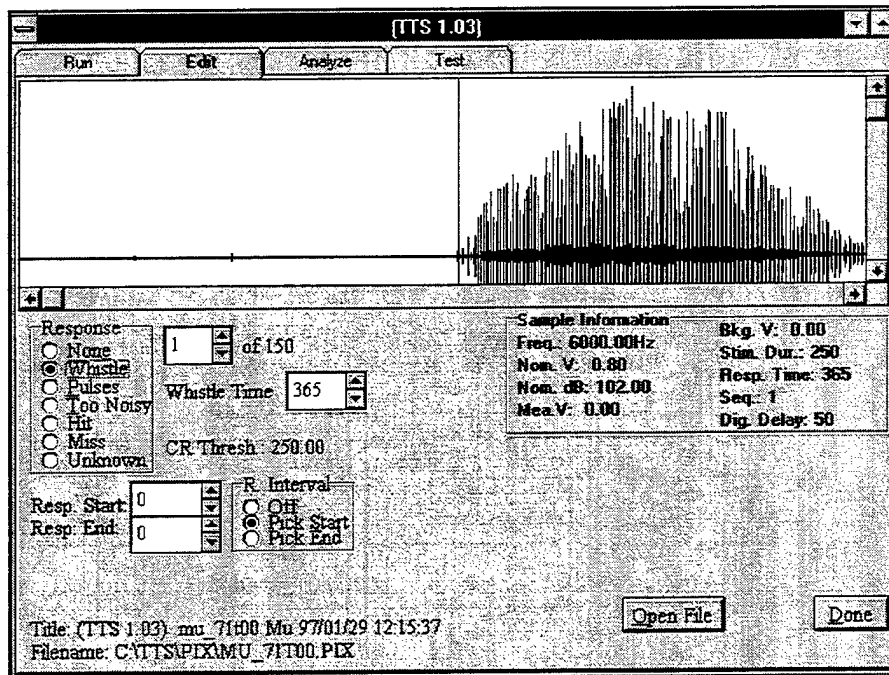

Figure 5. Image of computer screen during response editing.

vated by 6 dB for a minimum of 2 minutes following the louder S1. For the second and third test series, the 141 dB S1 was raised in approximately 10-dB steps, i.e., 151, 161, and 171 dB. Thereafter, the louder S1s were raised in approximately 6-dB steps until a 6-dB elevation in S2 threshold was observed.

A difference of 6 dB was used as the criterion for TTS because it was the minimum difference that would produce a statistical difference from the normal variation in baseline threshold. The normal baseline variation in hearing threshold was determined to be approximately 3 dB during the initial baseline testing period, or first phase, for each frequency. Selecting the minimum statistically significant threshold change to demonstrate a TTS effect also ensured that the test procedure would not result in permanent threshold shift (PTS). In fact, all animals had the same BNHT after testing was concluded as they did before TTS was induced.

After the first TTS values were obtained for the 20-kHz S1 signal, TTS for the 75-kHz S1 signal was obtained in the same way, and finally TTS was obtained for the 3-kHz S1 signal. There was an 8-week interruption in the testing schedule when the animals were kept away from the test enclosure while repairs were made to the piers and enclosure. No differences in performance were observed between the tests made before the interruption and those made after the interruption.

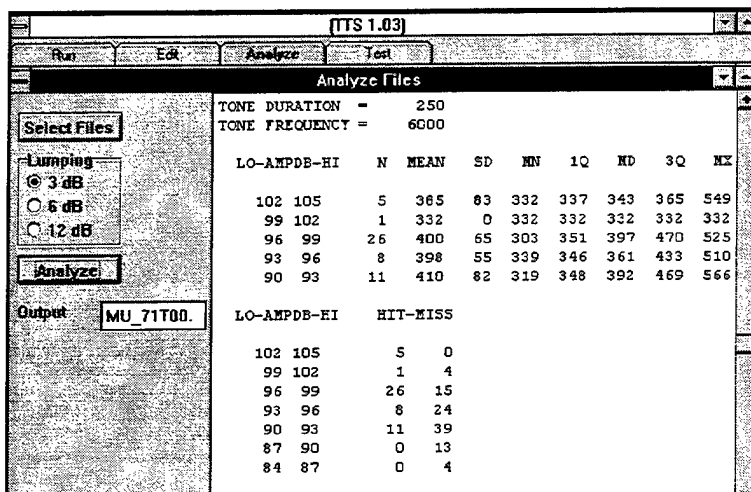

Figure 6. Image of computer screen during threshold determination analysis. The display identifies the file being analyzed, the S2 frequency tested, the number of hits (correct responses) and misses (no response) to S2 tones within a particular 3-dB bin, and descriptive information about hits (e.g., how many responses, mean latency of responses, standard deviation, range and quartiles of responses).

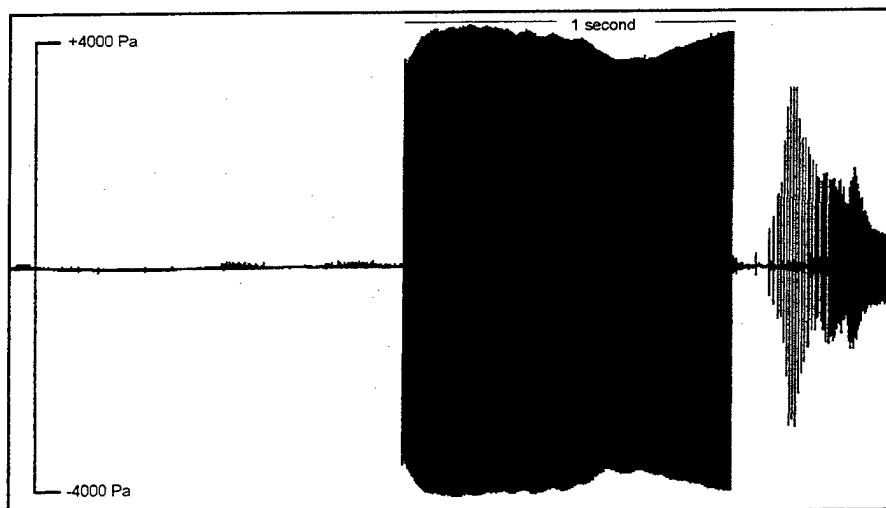

Figure 7. Louder S1 signal of 192 dB presented to dolphin NEM that produced TTS. Note the pulsatile response that follows the tone. This type of dolphin pulsatile sonic response was labelled a "mad" sound.

Equipment (Also, see appendix A.)

The tones for S1 were generated by the computer (figure 9) through a digital-to-analog (D/A) card, amplified with a Hafler Pro 5000 power amplifier or Crown Macro-Tech 2400, and delivered through a hydrophone projector suitable for the frequency and power level required (appendix A.). The power amplifier has a total harmonic distortion of less than 0.035% and a slew rate of 40 volts per ms and, therefore, did not limit the ramp-up rate of the tones.

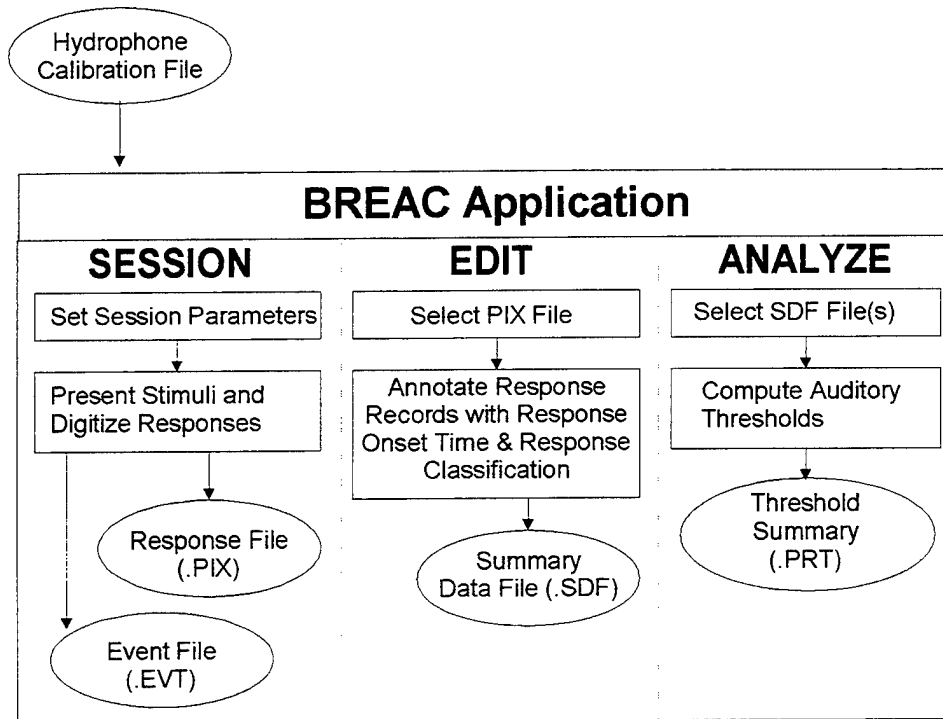

Figure 8. Diagram of computer program (BREAC) used for data collection and analysis.

The projectors used for 3-kHz, 20-kHz, and 75-kHz S1 tones were piezoelectric ceramic transducers. An AN/SSQ-62B projector served to emit the 3-kHz S1 tones. An International Transducer Corporation (ITC) Model ITC-1001 spherical projector provided the 20-kHz tone and an ITC-1042 provided the 75-kHz tone. At the highest levels of S1 presentation, the amplifier was near capacity and signals tended to vary about  $\pm 3$  dB from the nominal setting. Therefore, some S1s were lower or higher than the nominal incremental increase scheduled. The recorded level from hydrophone D (figure 3), rather than the nominal level, was used to determine the levels that produced TTS.

The S1 signals were monitored with a B&K 8103 hydrophone attached to the S1 station between the projector and the animal, adjacent to the animal's lower jaw so that this hydrophone (D in figure 3) received the same sound level as the dolphin. B&K 8103 hydrophones were selected for measurement transducers for their consistent calibration response across a broad range of frequencies (figure A-7). Calibration standards were traceable to the National Institute of Standards and Technology.

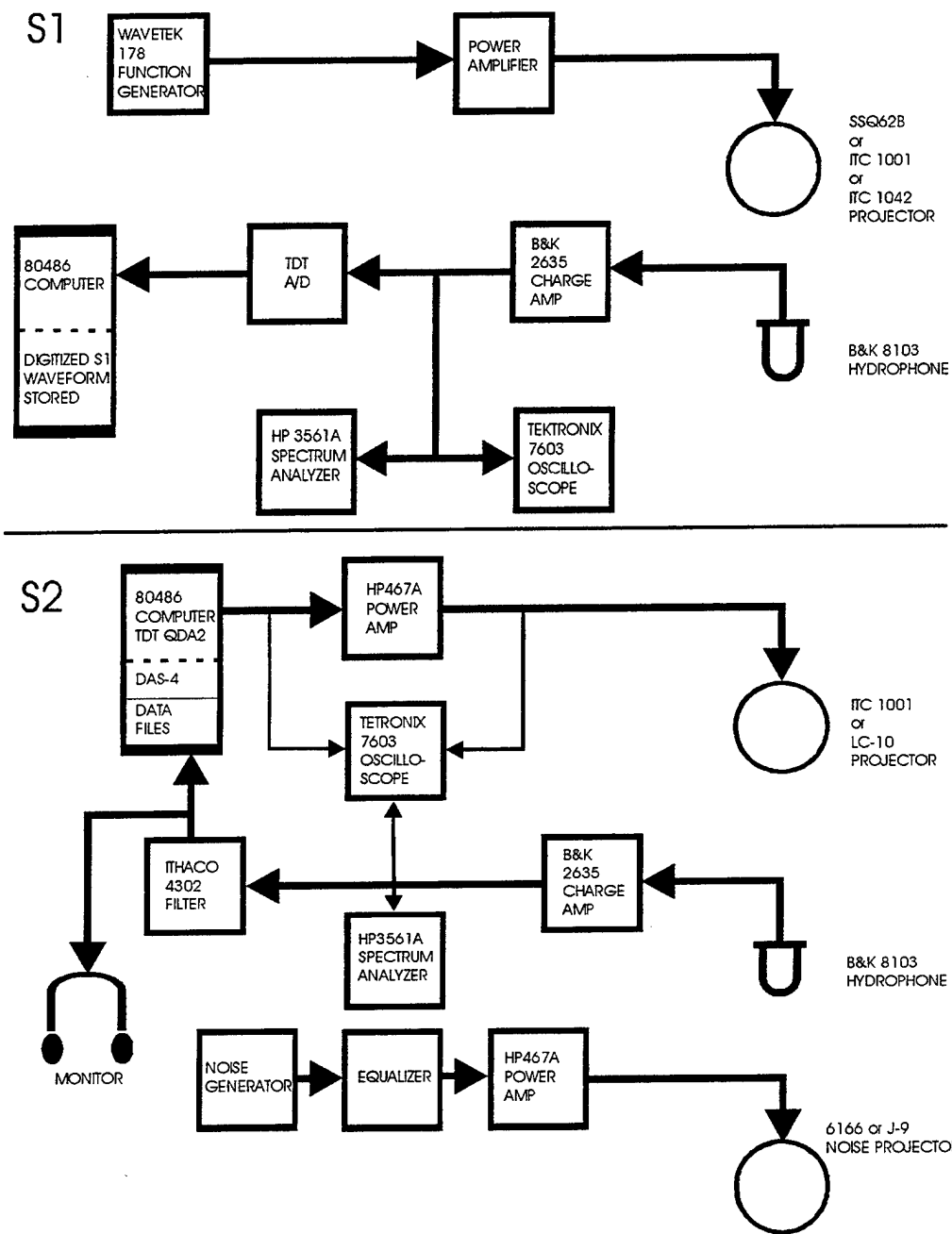

Figure 9. Schematic chart showing equipment setup for the hearing tests.

The received signal from the B&K 8103 was amplified by a B&K 2635 charge amplifier set to the charge sensitivity of the hydrophone, with the output digitized and measured on a system with Tucker-Davis Technologies data conversion system connected to a 80486 computer system. Sound level measurements for all louder S1 signals recorded from the B&K 8103 hydrophone adjacent to the dolphin's jaw were made with an HP 3561A analyzer, Tektronix 7603 oscilloscope and DSP software in the digitization and analysis computer.

All measurement hydrophones were individually calibrated. The B&K 4223 calibrator was accurate to  $\pm 0.3$  dB. All measurements included the response of the hydrophone plus charge amplifier. The measurements made with the HP 3561A spectrum analyzer were accurate to  $\pm 0.25$  dB.

Each louder S1 signal was recorded at a 500-kHz sample rate to ensure very precise determination of amplitude, frequency, and duration at the dolphin station. Each of the higher level S1s were digitized and analyzed individually (figure 7). The analog-to-digital (A/D) conversion system for capturing the S1s digitized the signals at 500 kHz with a conversion resolution of 16 bits. Even though S1s above 185 dB could be controlled to only  $\pm 3$  dB (a variation of about 1.5%), recording and digitizing each of these S1s allowed us to make an exact measurement of tone amplitude delivered at the animal within 1 dB after each test was completed. All measurements were rounded off to the nearest 1 dB.

The waveforms for S2 presentation were generated from a table containing relative hydrophone parameters stored on the computer hard disk (see figure 9). The table provided for a 5 ms rise time of the tone to full amplitude with the digital-to-analog (D/A) conversion through a Kiethley-Metrabyte DAS-4 card. The output of the DAS-4 D/A card was amplified with a Hewlett-Packard HP 467A power amplifier and delivered via a Celesco LC-10 projector.

The initial 90-dB masking noise level covering 3 kHz was generated with a Wavetek 132 white-noise generator amplified with the HP 467A and delivered through a Chesapeake J-9 projector. The 20-kHz and 75-kHz, 100-dB masking noise was generated with a custom-built noise generator amplified with the HP 467A and delivered through an Edo-Western 6166 projector (figure 9).

Calibrations were regularly checked with a B&K 4223 calibrator on the S1 and S2 monitor hydrophones. These calibrations kept system accuracy within  $\pm 1$  dB for all transmissions.

## STUDY RESULTS

Monthly progress reports were made to program sponsors by video teleconference. All project milestones were completed. In addition to the promised deliverables, four narrated video reports were provided, including a final 7-minute narrated video illustrating project accomplishments.

Four dolphins were employed in the project with two tested at each frequency. The identification and biological data for each animal are listed in table 2. Some typical raw data are provided in appendix B. Table 4 shows levels at which altered behavioral responses were observed after louder S1s at each frequency during the second phase of testing. Table 5 shows levels at which TTS was observed for each dolphin at each S1 frequency and statistics comparing TTS thresholds to BNHTs. One TTS value (APR at 3 kHz, 201 dB) met the criteria for TTS, based on the pattern of hits and misses on S2 tones following the 201 dB S1, but did not reach the *a priori* required level of statistical significance due to the limited number of repetitions and the presence of one response to a very-low-level S2 stimulus (an apparent outlier). The starting point for behavioral alterations for 3-kHz S1s was 186 dB while the lowest TTS value was at 194 dB. Table 6 provides an illustrative example of how the 3-kHz data might be used to establish monitoring/mitigation zones for a sound source, based on potential for inducing a marked

behavioral reaction or TTS at five different source levels and for three different propagation loss models. For interpolation between the two higher S1 frequencies (20 and 75 kHz) used in this study, levels above 178 dB for a signal of 1-s duration or less should be considered likely to induce a marked behavioral reaction, and levels above 192 dB should be considered likely to induce TTS, with a greater likelihood of TTS if exposed to levels above 192 dB at the higher frequencies (table 5). For bottlenose dolphins, products having source levels below 180 dB in the 3- to 100-kHz range and 1 s in duration should not require future TTS evaluation.

Table 4. Thresholds for observed altered behavior after louder S1s without TTS.

S1 Freq (kHz)	3		20		75	
Animal	NEM	APR	MUU	TOD	TOD	NEM
Date Tested	123196	109997	82796	82596	110496	110696
S1 Level (dB rms)	186	200	187	181	178	180
Behavioral Observations	Attacked biteplate	Porpoised away from louder S1, swam in circles, broke station 5X	Reluctant station on S1, very skittish	Turned in direction opposite S2	Very reluctant to go or return to S1	Stopped responding

### BEHAVIORAL OBSERVATIONS

At the trainers signal, animals were trained to swim directly to and station on the S1 biteplate (figure 3). Upon hearing the S1 signal from the S1 projector, animals were trained to leave the S1 biteplate, swim directly to and station on the S2 biteplate where they would be tested for hearing thresholds. During baseline testing, the S1 level was set at 141 dB, and the time required for animals to go from trainer to S1 biteplate, and from S1 biteplate to S2 biteplate, averaged about 8 s.

As the S1 level gradually increased, but before TTS was reached, animals began to exhibit alterations in their trained behavior (table 4). Altered behavior included swimming away from the S1 biteplate in the direction opposite the S2 station, porpoising away from the S1 biteplate, swimming quickly around the test pen several times, and breaking station at the S2 biteplate before stationing for threshold testing. On several occasions, animals attacked the S1 biteplate upon hearing the louder S1 signal. This included backing away from the biteplate initially, then rushing toward it, biting it, thrashing around, and shaking the entire underwater platform before going to the S2 station. In some instances, animals appeared reluctant to station on the S1 biteplate. Reluctance could be exhibited in several ways:

- 1) an animal might ignore the trainer's signal and swim around the test enclosure several times before going to the S1 station;
- 2) an animal might not station on the S1 biteplate properly, biting only the outermost edge of the biteplate (farthest away from the S1 projector) or at an angle to the S1 projector (as if preparing to leave quickly); and
- 3) an animal might leave the S1 biteplate early, before hearing the S1.

When the S1 reached levels that produced TTS, all of the above alterations in behavior continued to be observed. Additionally, animals often had to be given a second signal to go to the S2 station after hearing the louder S1 signal. Trainers needed to slap the water above the S2

biteplate continuously before the animal would swim to the underwater S2 station. Only on rare occasions after receiving the highest S1 levels (table 5 and figure 7) did an animal immediately swim directly to the S2 biteplate. Whether or not TTS occurred, instances of altered behavior at times had a pronounced effect on the interval between going from the trainer to the S1 biteplate (up to 10 min), and from the S1 biteplate to the S2 biteplate (up to 1 min 40 s).

## IMPACTS ON MARINE MAMMALS

Observations after presentation of the louder S1 signals (table 4 ) indicated that behavioral changes would be incurred at levels between the starting point level for change in behavior (178 dB) and the TTS level. There should be no biologically significant behavioral or physiological impact from 1-s tonal signals below this level. It is interesting that this level is similar in amplitude to the loudest whistles produced by these dolphins when received at a distance of 1 m.

At the two higher frequencies, 20 kHz and 75 kHz, the animal's received beam pattern is probably very significant in considering the potential impact of these high-frequency sources.<sup>9,10</sup> Because the actual orientation of a dolphin relative to the source is unknown, the most conservative interpretation would be to assume that the animal is oriented for optimal or maximal reception. In this study, both the S1 projector and the S2 projector were located directly in front of the animal along the most sensitive path of the received beam pattern<sup>9</sup> in both horizontal and vertical aspects (see figures 10a & b). Many sources are also directional. It is therefore important to consider the transmitting beam pattern of the source and the receiving beam pattern of the dolphin. Although data are not available on the received beam pattern at 3 kHz, this lower-frequency received beam will not likely be nearly so narrow and, thus, in effect, receipt of the 3-kHz source would have to be considered as somewhat omnidirectional, that is, the 3 kHz signal would likely produce a similar threshold if the sound source were directly to the side or below the dolphin. In contrast, the likelihood of a 75-kHz sound producing TTS would probably be considerably less if the source were to the side or below the dolphin (figures 10a & b).

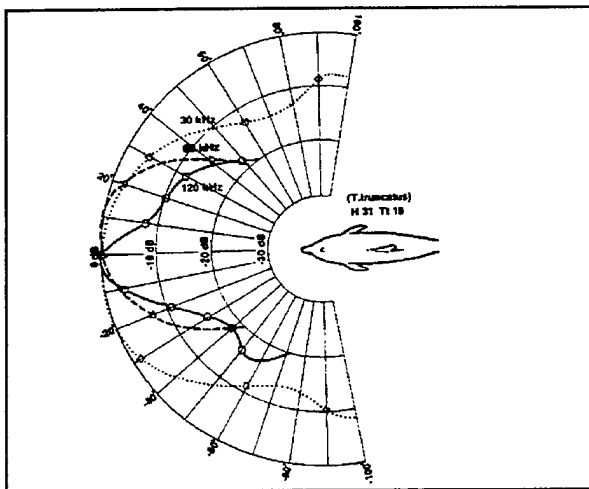

Figure 10a. Dolphin horizontal received beam pattern.<sup>9</sup>

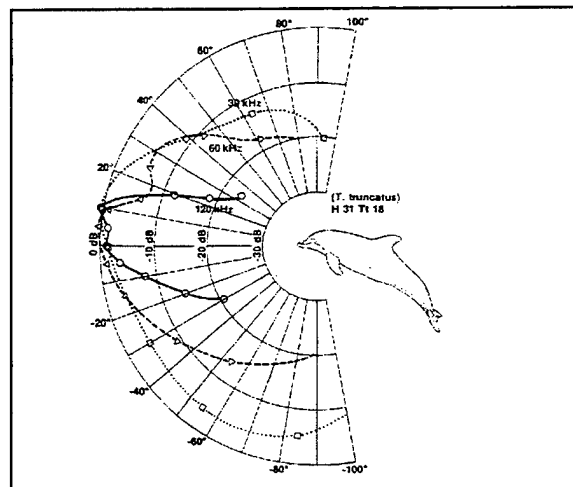

Figure 10b. Dolphin vertical received beam pattern.<sup>9</sup>

9. Au, W. L. and P. W. Moore. 1984. "Receiving Beam Patterns and Directivity Indices of the Atlantic Bottlenose Dolphin *Tursiops truncatus*." *Journal of the Acoustical Society of America* 75(1):255-262.

10. Popov, V. V., A. Y. Supin, and V. O. Klshin. 1992. "Electrophysiological Study of Sound Conduction in Dolphins." In *Marine Mammal Sensory Systems*, pp. 269-276. J. A. Thomas, R. A. Kastelein, and A. Y. Supin, Eds. Plenum Press, New York, NY.

Table 5. Thresholds, behavioral observations, and statistics for TTS to loudest S1s.

S1 Frequency	3 kHz		20 kHz		75 kHz	
	NEM	APR	MUU	TOD	TOD	NEM
Animal						
Masking Noise (dB rms)	90	90	100	100	100	100
BNHT (S1 @ 141 dB rms): Threshold (dB rms) / S2 Freq. (kHz)	96-99 / 3 no data/4.5 no data/6.0	102-105 / 3 no data/4.5 no data/6.0	96-99 / 20 no data/30 no data/40	93-96 / 20 no data/30 no data/40	96-99 / 75 no data/85 no data/100	no data/75 no data/85 84-87 / 100
Loudest S1 Level (dB rms)	194	201	193	196	194	192
Immed. Following Loudest S1, 0-3 min.: (TTS) $\Delta$ from Baseline (dB rms) / S2 Freq. (kHz)	+9 / 3	+6 / 3	+6 / 20	+6 / 20	+6 / 75	+21 / 100
After Loudest S1, 3-6 min.: $\Delta$ from Baseline (dB rms) / S2 Freq. (kHz)	+3 / 3	0 / 3	0 / 20	0 / 20	-6 / 75	+18 / 100
Later Same Session, 6-40 min.: $\Delta$ from Baseline (dB rms) / S2 Freq. (kHz)	no data/3 -3 / 4.5 -3 / 6	no data/3 -3 / 4.5 -12 / 6	-9 / 20 0 / 30 -3 / 40	no data/20 +6 / 30 -3 / 40	no data/75 -3 / 85 -3 / 100	no data/75 +18 / 85 no data/100
Behavioral Observations @ loudest S1	Nothing unusual, quick to go to S2	Broke station 1x, very reluctant to go to S1 thereafter	Reluctant to station on S1	Swam in circles, had to be cued to S2, reluctant to go on S1 biteplate thereafter	Reluctant to return to S1	Had to be cued to go to S2
BNHT ( $\bar{x} \pm s.d.$ ; N = 5)	95.6 $\pm$ 0.9	103.2 $\pm$ 1.1	93.5 $\pm$ 2.9	93.3 $\pm$ 0.8	96.8 $\pm$ 1.8	83.4 $\pm$ 1.8
Post-Loudest S1 Threshold ( $\bar{x} \pm s.d.$ ; N = 5)	104.1 $\pm$ 2.5	104.0 $\pm$ 3.7	100.5 $\pm$ 2.6	98.7 $\pm$ 2.1	98.6 $\pm$ 2.4	102.4 $\pm$ 3.0
Pre/Post $\Delta$ ( $\bar{x} \pm s.d.$ ; N = 5)	8.5 $\pm$ 1.9	0.8 $\pm$ 3.0	7.0 $\pm$ 1.4	5.4 $\pm$ 1.3	1.8 $\pm$ 1.5	19.0 $\pm$ 1.6
95% C.I.	6.18 - 10.82	-2.97 - 4.57	5.27 - 8.73	3.79 - 7.02	-0.04 - 3.64	17.04 - 20.9
One-Tailed T = (Post > Pre)	10.16	0.59	11.25	9.28	2.71	26.87
p value =	<0.001	NS	<0.001	<0.001	<0.05	<0.001

( $\bar{x}$  = mean, s.d. = standard deviation, N = sample size, p = probability/level of significance, NS = not significant)

Table 6. Hypothetical calculation of safe distances in meters (m) for a starting point for behavioral alteration and for TTS at 3 kHz only using five different source levels and three different propagation loss models: (A.) cylindrical spreading, 10 log R; (B.) a hybrid propagation model of 15 log R; and (C.) spherical spreading, 20 log R. Distances are figured both for behavioral change (186 dB) and for avoidance potential for TTS (194 dB) employing our most conservative results. These hypothetical distances are only examples. Detailed propagation loss models that take into account seasonal differences in propagation characteristics of the water column, local bathymetry, etc. (e.g., parabolic equation models such as FEPE) should be used whenever possible because they provide a more accurate prediction of actual propagation loss than spherical or cylindrical spreading loss models. Propagation losses are increased for higher frequencies. For example, absorption in the Atlantic Ocean is around 7 to 8 dB per mile for 20 kHz and around 50 dB per mile at 75 kHz.\* This acoustic absorption would have to be subtracted from the distances presented below. Therefore, the distances listed below would be shorter for 20- and 75-kHz sources.

**3-kHz source of 1 s duration or equivalent:**

**(A.) Cylindrical Spreading 10 log R**

(dB re 1 $\mu$ Pa) @ 1 meter (m)	Behavioral Change Distance (m)	TTS Distance (m)
230	25000	4000
220	2500	400
210	250	40
200	25	4.0
190	3	--

**(B.) Hybrid Spreading Model 15 log R**

(dB re 1 $\mu$ Pa) @ 1 m	Behavioral Change Distance (m)	TTS Distance (m)
230	858	254
220	181	56
210	41	12
200	9	3.5
190	3	--

**(C.) Spherical Spreading 20 log R**

(dB re 1 $\mu$ Pa) @ 1 m	Behavioral Change Distance (m)	TTS Distance (m)
230	160	64
220	50	20
210	16	6.3
200	6	2.0
190	1.6	--

\* Urick, R. J. 1983. *Principles of Underwater Sound for Engineers*, 3rd ed. McGraw-Hill, New York, NY.

## CONCLUSIONS

Studies to determine the presence or absence of TTS in response to 1-s tones of 141 to 201 dB were completed at 3 frequencies (3 kHz, 20 kHz, and 75 kHz) with four bottlenose dolphins. The studies were completed without any harm to animal health or significant change in day-to-day behavior. Short-term changes in behavior were observed above the following levels for 1-s S1 signals: 186 dB @ 3 kHz, 181 dB @ 20 kHz, and 178 dB @ 75 kHz. TTS levels were 194 to 201 dB @ 3 kHz, 193 to 196 dB @ 20 kHz, and 192 to 194 dB @ 75 kHz.

## FUTURE STUDIES

Follow-up studies are underway under the sponsorship of ONR to extend the frequency range, determine the effect of signal duration, and obtain taxonomic differences by testing other marine mammal species. These results are the first in a planned 3-year study. Other sources listed in table 1 will be considered, specifically 1.5 and 10 kHz. It is important to assess TTS levels at different signal durations.<sup>11, 12, 13</sup> For example, S1s of 500 ms, 250 ms, 100 ms, and 10 ms, should be assessed because such exposure durations are likely to occur in real-world test and operational situations. A curve or regression line could be built to relate time of exposure and level to probability for TTS. In addition, it will be important to study multiple exposures to tones of the above durations to get some idea of duty-cycle relationships with respect to TTS.

It will also be important to consider rise time of the S1 signal. When does the S1 tone become equivalent to an impulse? Is there a marked difference in behavioral response or in TTS between rapidly rising tones or impulses and those that rise slowly over several cycles or several milliseconds?

The current studies have also revealed effects outside the scope of the current studies that should be investigated (e.g., explosion effects and the Tullio phenomenon). In humans and other mammals, very loud sounds can produce vestibular effects—vertigo and nystagmus (rhythmic oscillation of the eyeballs). This may have happened in some of the dolphins at the higher amplitude levels of S1. This vestibular effect may be more easily measured than TTS at the lowest frequencies from 100 to 1000 Hz where dolphins have less hearing sensitivity.

## ACKNOWLEDGMENTS

We thank Michelle Reddy for the design, layout, production, and editing of this report. Mark Todd, Jennifer Carr, Monica Chaplin and Jack Gonzales helped with animal training and other technical aspects of the project. Tim McBride and Cy Frazier of PEO(USW) and Robert Gisiner of ONR gave us frequent encouragement during the work and provided helpful technical review of the manuscript at various stages. Stacie Andersen and Kim De Paul were also helpful in facilitating this work.

11. Ahroon, W. A., R. P. Hamernik, and S. Lei. 1996. "The Effects of Reverberant Blast Waves on the Auditory System." *Journal of the Acoustical Society of America* 100(4):2247—2257.

12. Jerger, J. F. 1955. "Influence of Stimulus Duration on the Pure-Tone Threshold During Recovery from Auditory Fatigue." *Journal of the Acoustical Society of America* 27(1):121—124.

13. Hirsh, T. J. and R. C. Bilger. 1955. "Auditory-Threshold Recovery after Exposures to Pure Tones." *Journal of the Acoustical Society of America* 27(6):1186—1194.

## **APPENDIX A: Equipment Used in the TTS Study and Calibration Graphs**

### **S1 Signal Projectors**

3 kHz            AN/SSQ-62B (Figure A-1)  
20 kHz          International Transducer Corporation -1001 (Figure A-2)  
75 kHz          International Transducer Corporation -1042 (Figure A-3, Figure A-4)

### **S2 Tone Projector**

Celesco LC-10

### **Masking Noise Source**

Wavetek 132

### **Masking Noise Projectors**

20 and 75 kHz      Edo-Western 6166 (Figure A-5)  
3 kHz                Chesapeake J-9 (Figure A-6)

### **Calibration and Monitoring S1 and S2 Sounds**

Bruel & Kjaer 8103 hydrophones (Figure A-7)  
Bruel & Kjaer 2635 charge amplifiers (Figure A-8)

### **Sound Measurement**

Bruel & Kjaer 4223 Calibrator  
Hewlett Packard (HP) 3561A Spectrum Analyzer  
Tektronix 7603 Oscilloscope  
Tucker-Davis Technologies analog-to-digital conversion system on 80486 computer

### **Analysis Software**

DSP Development Corporation

### **Sound Projector Amplifiers**

S2 and Masking Noise: HP 467A  
S1: Hafler Pro 5000 or  
Crown Macro-Tech 2400 (Figure A-9)

### **Filter**

Ithaco 4302 (4 pole Butterworth high and low pass 24 dB per octave)

### **Equalizers**

Kenwood Stereo Graphic Equalizer KE-294 for 1-11 kHz noise.  
Custom Noise Source/Equalizer produced in this laboratory by W. L. Au for higher frequencies.

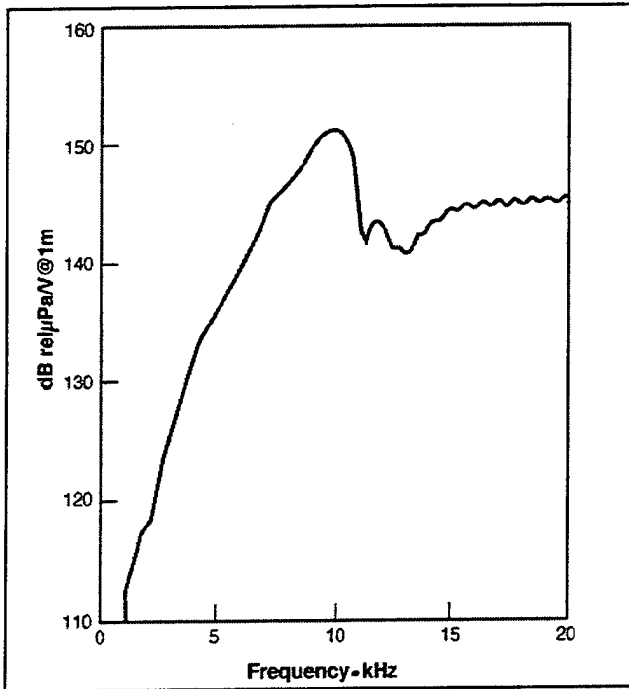

Figure A-1. AN/SSQ-62B Projector voltage source level response.

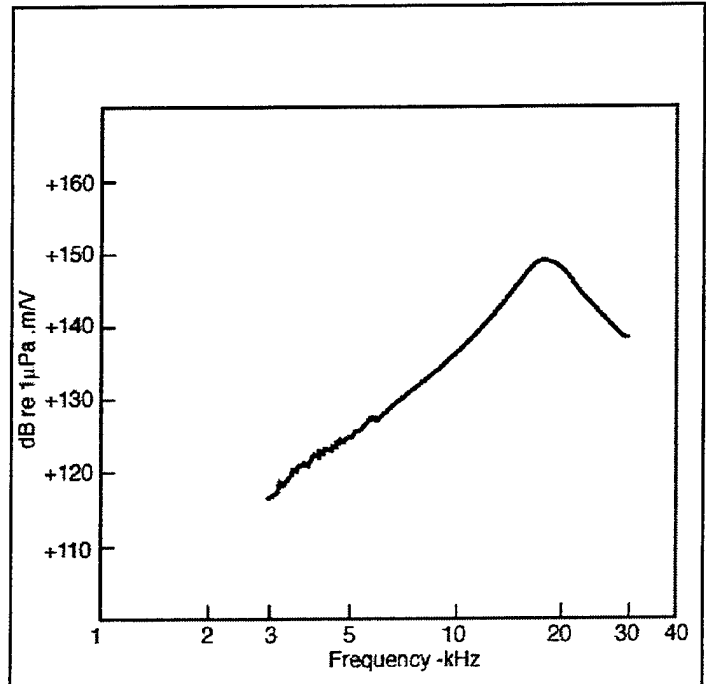

Figure A-2. ITC-1001 Projector voltage source level response.

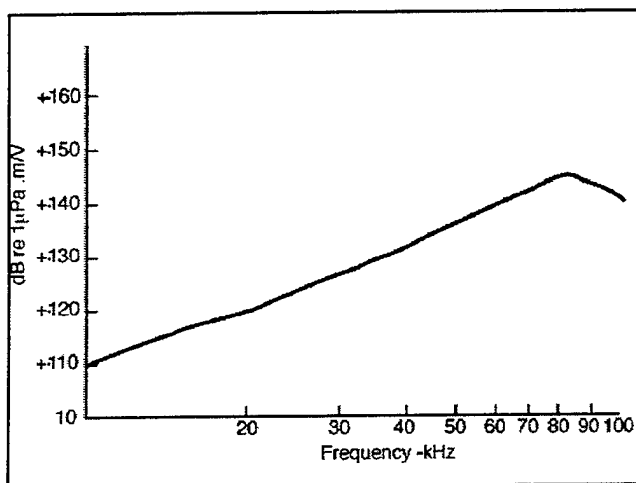

Figure A-3. ITC-1042 Projector voltage source level response.

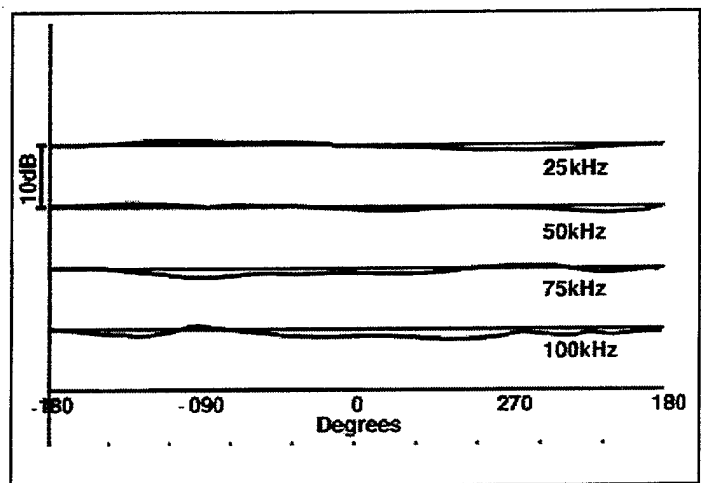

Figure A-4. X-Y Directivity pattern vs. frequency ITC-1042.

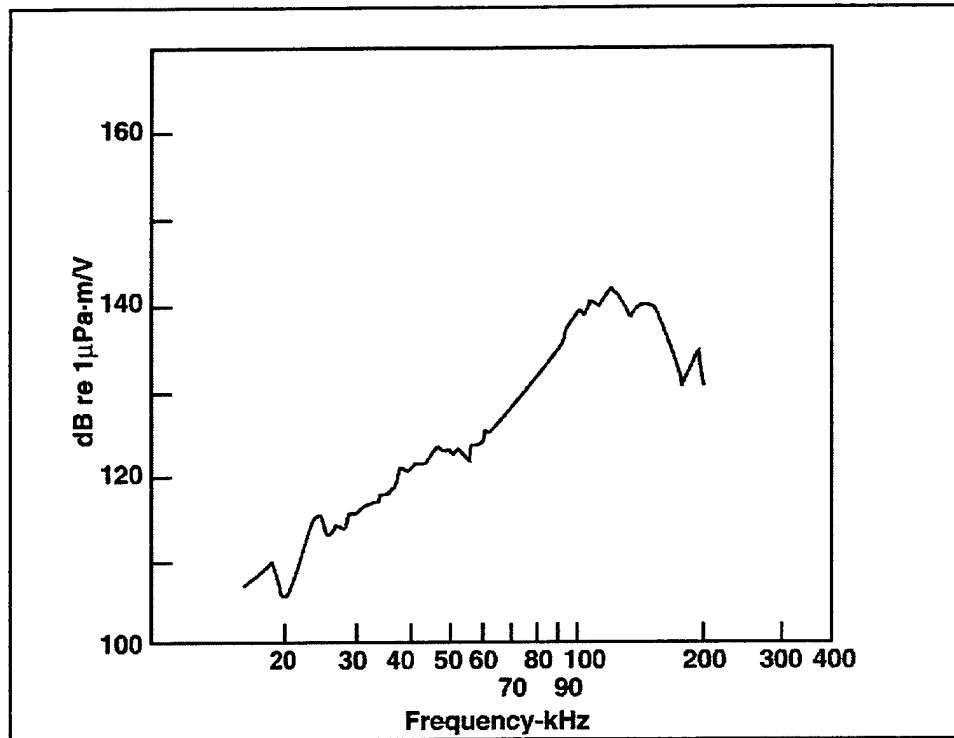

Figure A-5. Edo-Western 6166 Projector voltage source level response.

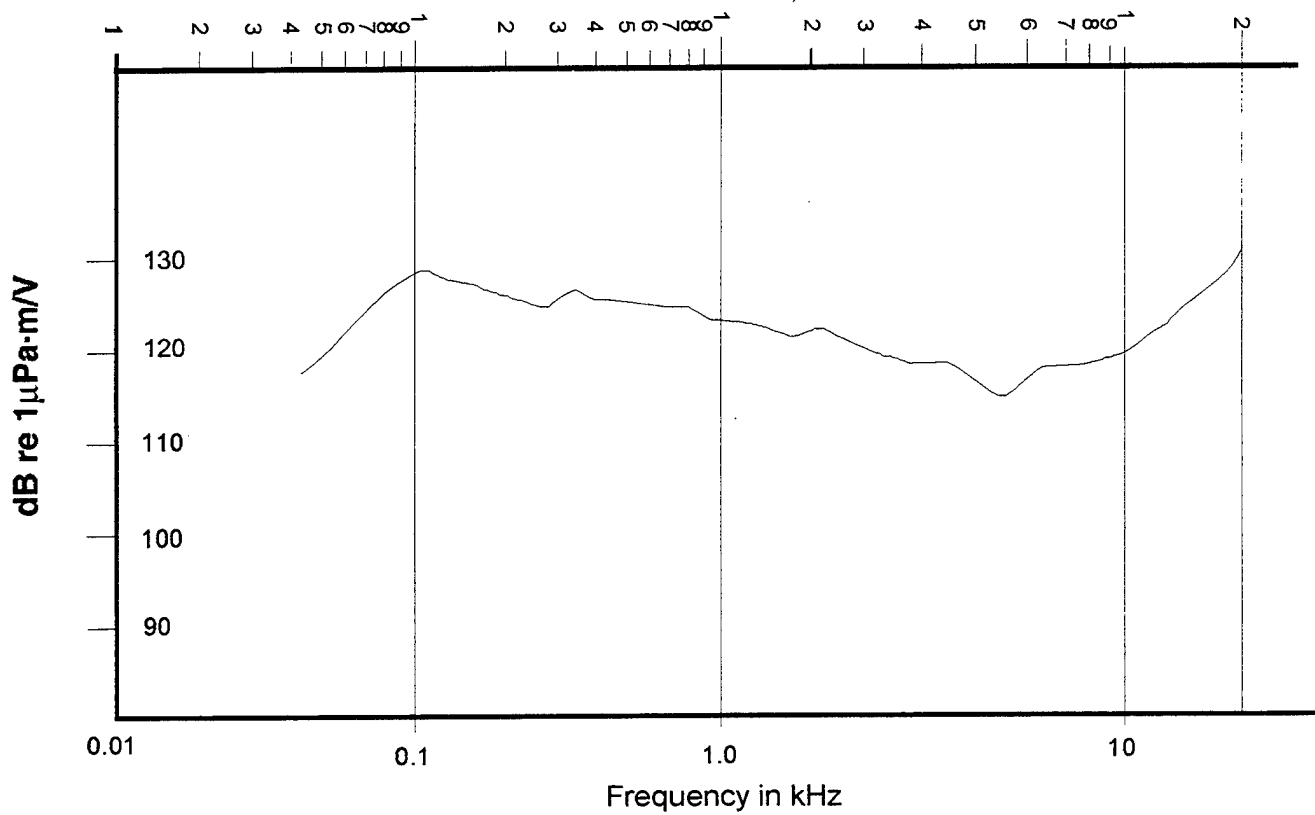

Figure A-6. J-9 Projector voltage source level response.

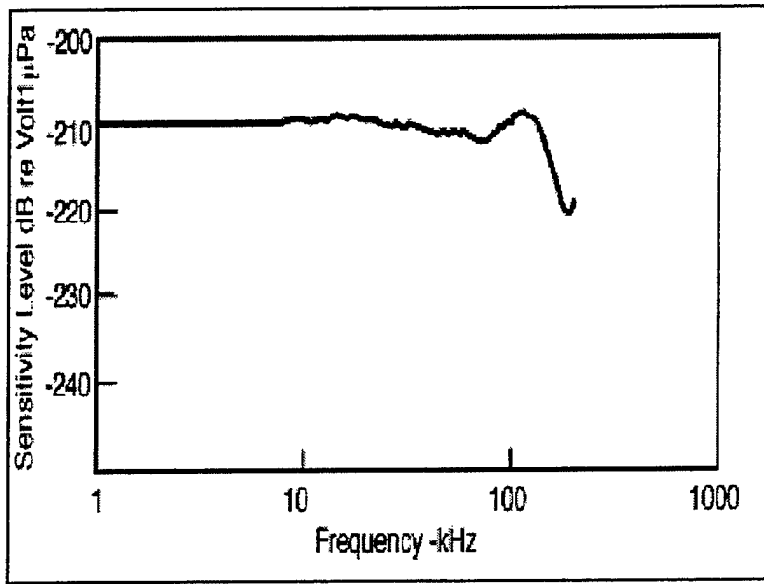

Figure A-7. Bruel & Kjaer 8103 Hydrophone receive sensitivity response.

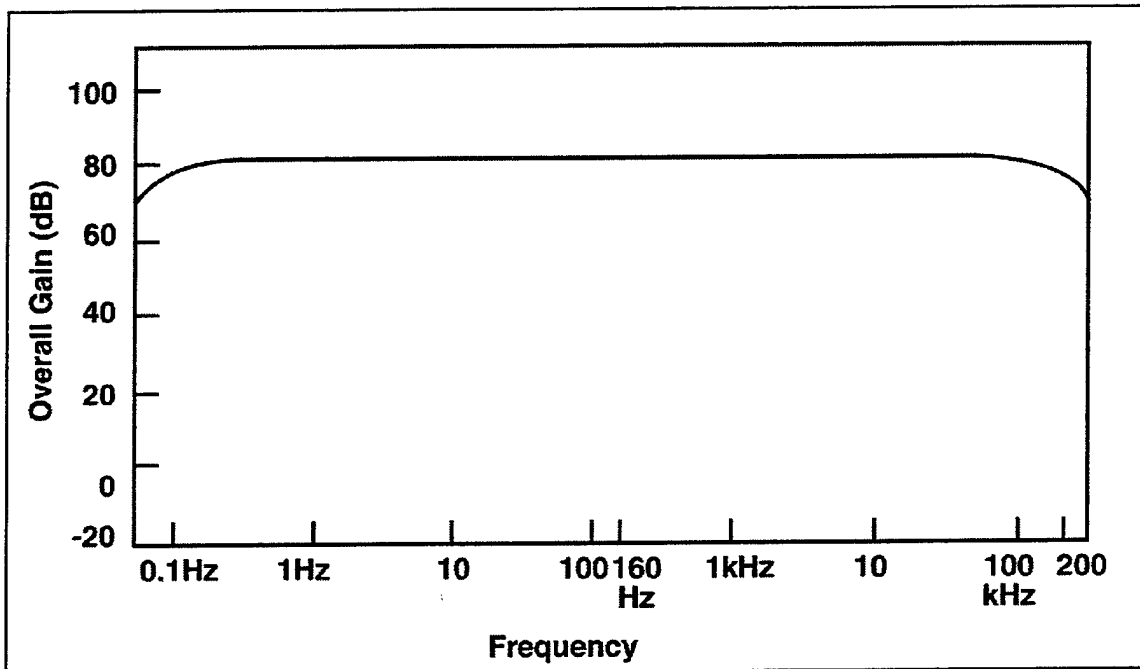

Figure A-8. Bruel & Kjaer 2635 Charge Amplifier frequency response.

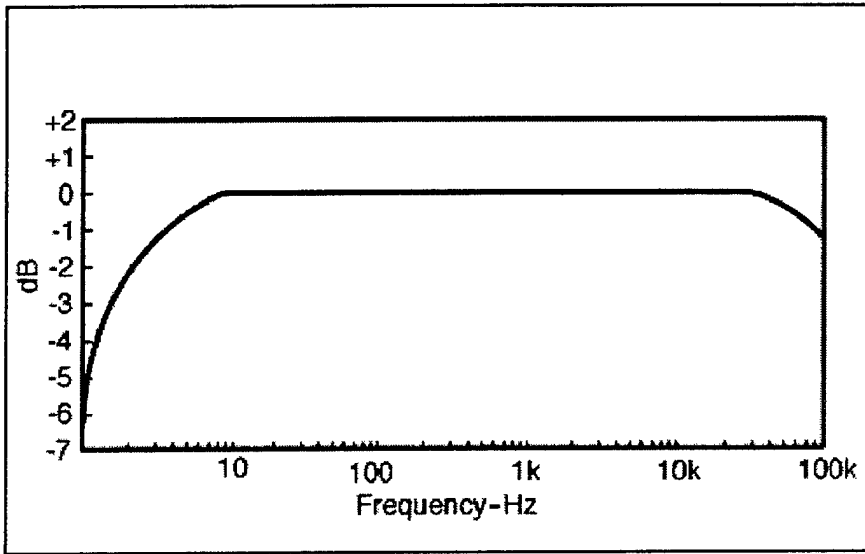

Figure A-9. Crown Macro-Tech 2400 Power Amplifier frequency response curve.

## APPENDIX B: Raw Data for TTS to Louder S1 Signals

### Key

Field 0 is the number of S2 tones in the session overall

Field 1 is the stimulus type, pure tone

Field 2 is the number of tones in that trial

Field 4 is the dB

Field 5 and 6 were inactive and should be disregarded

Field 7 is the S2 frequency

Field 8 is the duration of the S2 tone

Field 9 is the response latency

Field 10 is the observed response type (0=no response, 1=whistle, 2=pulse, 3=disregard trial)

Field 11 was inactive and should be disregarded

Field 12 is the response result code (N=no response, blank=whistle, W=pulse, T=disregard trial)

(TTS 1.02) nem71a00 Nemo 97/01/10 11:34:10

FIELD 00 POINT NUMBER	I 03
FIELD 01 STIMULUS TYPE	I 01
FIELD 02 STIMULUS SEQ NUMBER	I 03
FIELD 03 STIMULUS NOMINAL AMP (V)	R 10
FIELD 04 STIMULUS NOMINAL AMP (dB)	R 10
FIELD 05 STIMULUS MEAS AMP (V)	R 10
FIELD 06 BACKGROUND AMP (V)	R 10
FIELD 07 STIMULUS FREQUENCY(HZ)	R 10
FIELD 08 STIMULUS DURATION (MSEC)	I 03
FIELD 09 RESPONSE TIME (MSEC)	I 03
FIELD 10 OBSERVED RESPONSE TYPE	I 01
FIELD 11 CORRECT RESPONSE TYPE	I 01
FIELD 12 RESPONSE RESULT CODE	C 01

POINT 1 1 1	6.92	106.00	0.00	0.00	3000.00	250 434 0 1 N
POINT 2 1 2	6.92	106.00	0.00	0.00	3000.00	250 290 0 1 N
POINT 3 1 3	8.71	108.00	0.00	0.00	3000.00	250 470 1 1
POINT 4 1 4	5.50	104.00	0.00	0.00	3000.00	250 675 0 1 N
POINT 5 1 5	6.92	106.00	0.00	0.00	3000.00	250 700 0 1 N
POINT 6 1 6	8.71	108.00	0.00	0.00	3000.00	250 437 1 1
POINT 7 1 7	5.50	104.00	0.00	0.00	3000.00	250 490 1 1
POINT 8 1 8	3.47	100.00	0.00	0.00	3000.00	250 129 0 1 N
POINT 9 1 9	4.37	102.00	0.00	0.00	3000.00	250 168 0 1 N
POINT 10 1 10	5.50	104.00	0.00	0.00	3000.00	250 343 1 1
POINT 11 1 11	3.47	100.00	0.00	0.00	3000.00	250 503 0 1 N
POINT 12 1 12	4.37	102.00	0.00	0.00	3000.00	250 149 0 1 N
POINT 13 1 13	5.50	104.00	0.00	0.00	3000.00	250 465 1 1
POINT 14 1 1	2.19	96.00	0.00	0.00	3000.00	250 556 1 1
POINT 15 1 2	2.19	96.00	0.00	0.00	3000.00	250 505 0 1 N
POINT 16 1 3	2.75	98.00	0.00	0.00	3000.00	250 493 0 1 N
POINT 17 1 4	3.47	100.00	0.00	0.00	3000.00	250 441 1 1
POINT 18 1 5	2.19	96.00	0.00	0.00	3000.00	250 336 1 1
POINT 19 1 6	1.38	92.00	0.00	0.00	3000.00	250 89 2 1 W
POINT 20 1 7	1.74	94.00	0.00	0.00	3000.00	250 682 0 1 N
POINT 21 1 8	2.19	96.00	0.00	0.00	3000.00	250 592 0 1 N
POINT 22 1 9	2.75	98.00	0.00	0.00	3000.00	250 363 1 1
POINT 23 1 10	1.74	94.00	0.00	0.00	3000.00	250 89 2 1 W
POINT 24 1 11	2.19	96.00	0.00	0.00	3000.00	250 346 0 1 N
POINT 25 1 12	2.75	98.00	0.00	0.00	3000.00	250 152 2 1 W
POINT 26 1 13	3.47	100.00	0.00	0.00	3000.00	250 312 1 1
POINT 27 1 14	2.19	96.00	0.00	0.00	3000.00	250 451 1 1
POINT 28 1 15	1.38	92.00	0.00	0.00	3000.00	250 206 2 1 W
POINT 29 1 16	1.74	94.00	0.00	0.00	3000.00	250 410 1 1
POINT 30 1 17	1.38	92.00	0.00	0.00	3000.00	250 424 0 1 N
POINT 31 1 18	1.74	94.00	0.00	0.00	3000.00	250 700 0 1 N
POINT 32 1 19	2.19	96.00	0.00	0.00	3000.00	250 351 0 1 N
POINT 33 1 20	2.75	98.00	0.00	0.00	3000.00	250 335 1 1
POINT 34 1 21	1.74	94.00	0.00	0.00	3000.00	250 302 0 1 N
POINT 35 1 22	2.19	96.00	0.00	0.00	3000.00	250 336 1 1
POINT 36 1 23	1.38	92.00	0.00	0.00	3000.00	250 133 0 1 N
POINT 37 1 24	1.74	94.00	0.00	0.00	3000.00	250 700 0 1 N
POINT 38 1 25	2.19	96.00	0.00	0.00	3000.00	250 403 1 1



(TTS 1.02) nem71a02 Nemo 97/01/10 11:43:46

FIELD 00 POINT NUMBER	I 03
FIELD 01 STIMULUS TYPE	I 01
FIELD 02 STIMULUS SEQ NUMBER	I 03
FIELD 03 STIMULUS NOMINAL AMP (V)	R 10
FIELD 04 STIMULUS NOMINAL AMP (dB)	R 10
FIELD 05 STIMULUS MEAS AMP (V)	R 10
FIELD 06 BACKGROUND AMP (V)	R 10
FIELD 07 STIMULUS FREQUENCY(HZ)	R 10
FIELD 08 STIMULUS DURATION (MSEC)	I 03
FIELD 09 RESPONSE TIME (MSEC)	I 03
FIELD 10 OBSERVED RESPONSE TYPE	I 01
FIELD 11 CORRECT RESPONSE TYPE	I 01
FIELD 12 RESPONSE RESULT CODE	C 01

POINT 1 1 1	1.58	102.00	0.00	0.00	4500.00	250 346 2 1 W
POINT 2 1 2	1.58	102.00	0.00	0.00	4500.00	250 506 2 1 W
POINT 3 1 3	2.00	104.00	0.00	0.00	4500.00	250 320 1 1
POINT 4 1 4	1.26	100.00	0.00	0.00	4500.00	250 356 1 1
POINT 5 1 5	0.79	96.00	0.00	0.00	4500.00	250 89 2 1 W
POINT 6 1 6	1.00	98.00	0.00	0.00	4500.00	250 89 2 1 W
POINT 7 1 7	1.26	100.00	0.00	0.00	4500.00	250 438 2 1 W
POINT 8 1 8	1.58	102.00	0.00	0.00	4500.00	250 261 1 1
POINT 9 1 9	1.00	98.00	0.00	0.00	4500.00	250 89 2 1 W
POINT 10 1 10	1.26	100.00	0.00	0.00	4500.00	250 89 2 1 W
POINT 11 1 11	1.58	102.00	0.00	0.00	4500.00	250 268 1 1
POINT 12 1 12	1.00	98.00	0.00	0.00	4500.00	250 531 2 1 W
POINT 13 1 13	1.26	100.00	0.00	0.00	4500.00	250 326 1 1
POINT 14 1 14	0.79	96.00	0.00	0.00	4500.00	250 286 1 1
POINT 15 1 15	0.50	92.00	0.00	0.00	4500.00	250 89 2 1 W
POINT 16 1 16	0.63	94.00	0.00	0.00	4500.00	250 322 1 1
POINT 17 1 17	0.40	90.00	0.00	0.00	4500.00	250 531 0 1 N
POINT 18 1 18	0.50	92.00	0.00	0.00	4500.00	250 447 1 1
POINT 19 1 19	0.32	88.00	0.00	0.00	4500.00	250 622 0 1 N
POINT 20 1 20	0.40	90.00	0.00	0.00	4500.00	250 490 1 1
POINT 21 1 21	0.25	86.00	0.00	0.00	4500.00	250 89 0 1 N
POINT 22 1 22	0.32	88.00	0.00	0.00	4500.00	250 700 0 1 N
POINT 23 1 23	0.40	90.00	0.00	0.00	4500.00	250 225 0 1 N
POINT 24 1 24	0.50	92.00	0.00	0.00	4500.00	250 498 1 1
POINT 25 1 25	0.32	88.00	0.00	0.00	4500.00	250 293 0 1 N
POINT 26 1 26	0.40	90.00	0.00	0.00	4500.00	250 563 0 1 N
POINT 27 1 27	0.50	92.00	0.00	0.00	4500.00	250 406 1 1
POINT 28 1 28	0.32	88.00	0.00	0.00	4500.00	250 510 0 1 N
POINT 29 1 29	0.40	90.00	0.00	0.00	4500.00	250 602 0 1 N
POINT 30 1 30	0.50	92.00	0.00	0.00	4500.00	250 541 0 1 N
POINT 31 1 31	0.63	94.00	0.00	0.00	4500.00	250 434 1 1
POINT 32 1 1	0.32	94.00	0.00	0.00	6000.00	250 89 0 1 N
POINT 33 1 2	0.40	96.00	0.00	0.00	6000.00	250 89 0 1 N
POINT 34 1 3	0.51	98.00	0.00	0.00	6000.00	250 632 0 1 N
POINT 35 1 4	0.64	100.00	0.00	0.00	6000.00	250 342 0 1 N
POINT 36 1 5	0.80	102.00	0.00	0.00	6000.00	250 485 0 1 N
POINT 37 1 6	1.01	104.00	0.00	0.00	6000.00	250 700 0 1 N
POINT 38 1 7	1.27	106.00	0.00	0.00	6000.00	250 184 0 1 N
POINT 39 1 8	1.60	108.00	0.00	0.00	6000.00	250 314 1 1
POINT 40 1 9	1.01	104.00	0.00	0.00	6000.00	250 316 1 1

POINT 41	1	10	0.64	100.00	0.00	0.00	6000.00	250	310	1	1
POINT 42	1	11	0.40	96.00	0.00	0.00	6000.00	250	369	1	1
POINT 43	1	12	0.25	92.00	0.00	0.00	6000.00	250	619	2	1 W
POINT 44	1	13	0.32	94.00	0.00	0.00	6000.00	250	89	2	1 W
POINT 45	1	14	0.40	96.00	0.00	0.00	6000.00	250	668	2	1 W
POINT 46	1	15	0.51	98.00	0.00	0.00	6000.00	250	371	1	1
POINT 47	1	16	0.32	94.00	0.00	0.00	6000.00	250	374	1	1
POINT 48	1	17	0.40	96.00	0.00	0.00	6000.00	250	166	2	1 W
POINT 49	1	18	0.51	98.00	0.00	0.00	6000.00	250	346	1	1
POINT 50	1	19	0.32	94.00	0.00	0.00	6000.00	250	382	1	1
POINT 51	1	20	0.20	90.00	0.00	0.00	6000.00	250	271	2	1 W
POINT 52	1	21	0.25	92.00	0.00	0.00	6000.00	250	332	2	1 W
POINT 53	1	22	0.32	94.00	0.00	0.00	6000.00	250	412	1	1
POINT 54	1	23	0.20	90.00	0.00	0.00	6000.00	250	89	2	1 W
POINT 55	1	24	0.25	92.00	0.00	0.00	6000.00	250	306	1	1
POINT 56	1	1	0.16	88.00	0.00	0.00	6000.00	250	321	0	1 N
POINT 57	1	2	0.20	90.00	0.00	0.00	6000.00	250	700	0	1 N
POINT 58	1	3	0.25	92.00	0.00	0.00	6000.00	250	89	0	1 N
POINT 59	1	4	0.32	94.00	0.00	0.00	6000.00	250	197	0	1 N
POINT 60	1	5	0.40	96.00	0.00	0.00	6000.00	250	483	0	1 N
POINT 61	1	6	0.51	98.00	0.00	0.00	6000.00	250	700	0	1 N
POINT 62	1	7	0.64	100.00	0.00	0.00	6000.00	250	299	0	1 N
POINT 63	1	8	0.80	102.00	0.00	0.00	6000.00	250	338	1	1
POINT 64	1	9	0.51	98.00	0.00	0.00	6000.00	250	565	0	1 N
POINT 65	1	10	0.64	100.00	0.00	0.00	6000.00	250	89	0	1 N
POINT 66	1	11	0.80	102.00	0.00	0.00	6000.00	250	456	0	1 N
POINT 67	1	12	1.01	104.00	0.00	0.00	6000.00	250	259	1	1
POINT 68	1	13	0.64	100.00	0.00	0.00	6000.00	250	655	0	1 N
POINT 69	1	14	0.80	102.00	0.00	0.00	6000.00	250	367	1	1
POINT 70	1	15	0.51	98.00	0.00	0.00	6000.00	250	317	0	1 N
POINT 71	1	16	0.64	100.00	0.00	0.00	6000.00	250	403	0	1 N
POINT 72	1	17	0.80	102.00	0.00	0.00	6000.00	250	298	1	1
POINT 73	1	18	0.51	98.00	0.00	0.00	6000.00	250	380	1	1
POINT 74	1	19	0.32	94.00	0.00	0.00	6000.00	250	500	0	1 N
POINT 75	1	20	0.40	96.00	0.00	0.00	6000.00	250	389	1	1
POINT 76	1	21	0.25	92.00	0.00	0.00	6000.00	250	310	0	1 N
POINT 77	1	22	0.32	94.00	0.00	0.00	6000.00	250	154	2	1 W
POINT 78	1	23	0.40	96.00	0.00	0.00	6000.00	250	453	1	1
POINT 79	1	24	0.25	92.00	0.00	0.00	6000.00	250	481	1	1
POINT 80	1	1	2.75	98.00	0.00	0.00	3000.00	250	89	0	1 N
POINT 81	1	2	3.47	100.00	0.00	0.00	3000.00	250	362	0	1 N
POINT 82	1	3	4.37	102.00	0.00	0.00	3000.00	250	213	0	1 N
POINT 83	1	4	5.50	104.00	0.00	0.00	3000.00	250	354	1	1
POINT 84	1	5	3.47	100.00	0.00	0.00	3000.00	250	342	1	1
POINT 85	1	6	2.19	96.00	0.00	0.00	3000.00	250	350	0	1 N
POINT 86	1	7	2.75	98.00	0.00	0.00	3000.00	250	89	0	1 N
POINT 87	1	8	3.47	100.00	0.00	0.00	3000.00	250	277	0	1 N
POINT 88	1	9	4.37	102.00	0.00	0.00	3000.00	250	399	1	1
POINT 89	1	10	2.75	98.00	0.00	0.00	3000.00	250	498	1	1
POINT 90	1	11	1.74	94.00	0.00	0.00	3000.00	250	690	0	1 N
POINT 91	1	12	2.19	96.00	0.00	0.00	3000.00	250	502	1	1
POINT 92	1	13	1.38	92.00	0.00	0.00	3000.00	250	225	0	1 N
POINT 93	1	14	1.74	94.00	0.00	0.00	3000.00	250	89	0	1 N
POINT 94	1	15	2.19	96.00	0.00	0.00	3000.00	250	89	0	1 N

POINT 95	1	16	2.75	98.00	0.00	0.00	3000.00	250	302	0	1	N
POINT 96	1	17	3.47	100.00	0.00	0.00	3000.00	250	280	1	1	
POINT 97	1	18	2.19	96.00	0.00	0.00	3000.00	250	531	0	1	N
POINT 98	1	19	2.75	98.00	0.00	0.00	3000.00	250	338	0	1	N
POINT 99	1	20	3.47	100.00	0.00	0.00	3000.00	250	89	0	1	N
POINT 100	1	21	4.37	102.00	0.00	0.00	3000.00	250	349	1	1	
POINT 101	1	22	2.75	98.00	0.00	0.00	3000.00	250	89	0	1	N
POINT 102	1	23	3.47	100.00	0.00	0.00	3000.00	250	433	1	1	
POINT 103	1	24	2.19	96.00	0.00	0.00	3000.00	250	89	0	1	N
POINT 104	1	25	2.75	98.00	0.00	0.00	3000.00	250	181	0	1	N
POINT 105	1	26	3.47	100.00	0.00	0.00	3000.00	250	545	1	1	
POINT 106	1	27	2.19	96.00	0.00	0.00	3000.00	250	150	0	1	N
POINT 107	1	28	1.38	92.00	0.00	0.00	3000.00	250	575	0	1	N
POINT 108	1	29	1.74	94.00	0.00	0.00	3000.00	250	398	0	1	N
POINT 109	1	30	2.19	96.00	0.00	0.00	3000.00	250	226	0	1	N
POINT 110	1	31	2.75	98.00	0.00	0.00	3000.00	250	312	1	1	
POINT 111	1	1	1.74	94.00	0.00	0.00	3000.00	250	473	0	1	N
POINT 112	1	2	2.19	96.00	0.00	0.00	3000.00	250	411	0	1	N
POINT 113	1	3	2.75	98.00	0.00	0.00	3000.00	250	700	0	1	N
POINT 114	1	4	3.47	100.00	0.00	0.00	3000.00	250	702	0	1	N
POINT 115	1	5	4.37	102.00	0.00	0.00	3000.00	250	89	0	1	N
POINT 116	1	6	5.50	104.00	0.00	0.00	3000.00	250	498	0	1	N
POINT 117	1	7	6.92	106.00	0.00	0.00	3000.00	250	89	0	1	N
POINT 118	1	8	8.71	108.00	0.00	0.00	3000.00	250	308	1	1	
POINT 119	1	9	5.50	104.00	0.00	0.00	3000.00	250	89	2	1	W
POINT 120	1	10	6.92	106.00	0.00	0.00	3000.00	250	368	2	1	W
POINT 121	1	11	8.71	108.00	0.00	0.00	3000.00	250	257	1	1	
POINT 122	1	12	5.50	104.00	0.00	0.00	3000.00	250	89	2	1	W
POINT 123	1	13	6.92	106.00	0.00	0.00	3000.00	250	384	1	1	
POINT 124	1	14	4.37	102.00	0.00	0.00	3000.00	250	460	2	1	W
POINT 125	1	15	5.50	104.00	0.00	0.00	3000.00	250	367	1	1	



21a. NAME OF RESPONSIBLE INDIVIDUAL

Sam H. Ridgway

21b. TELEPHONE (include Area Code)

(619) 553-1374

e-mail: ridgway@nosc.mil

21c. OFFICE SYMBOL

Code D3503

## INITIAL DISTRIBUTION

Code D0012	Patent Counsel	(1)
Code D0271	Archive/Stock	(6)
Code D0274	Library	(2)
Code D0271	D. Richter	(1)
Code D35	J. Haun	(1)
Code D3503	S. Ridgway	(42)
Code D351	P. Moore	(1)
Code D351	D. Carder	(5)
Code D351	R. Brill	(1)
Code D351	P. Nachtigall	(1)
Code D351	W. L. Au	(1)
Code D352	R. Kataoka	(1)

Defense Technical Information Center  
Fort Belvoir, VA 22060-6218 (4)

NCCOSC Washington Liaison Office  
Washington, DC 20363-5100

Center for Naval Analyses  
Alexandria, VA 22302-0268

Navy Acquisition, Research and Development  
Information Center (NARDIC)  
Arlington, VA 22244-5114

GIDEP Operations Center  
Corona, CA 91718-8000

Program Executive Officer (USW) L  
Arlington, VA 22242-5169 (40)

Office of Naval Research  
Arlington, VA 22217-5660 (10)

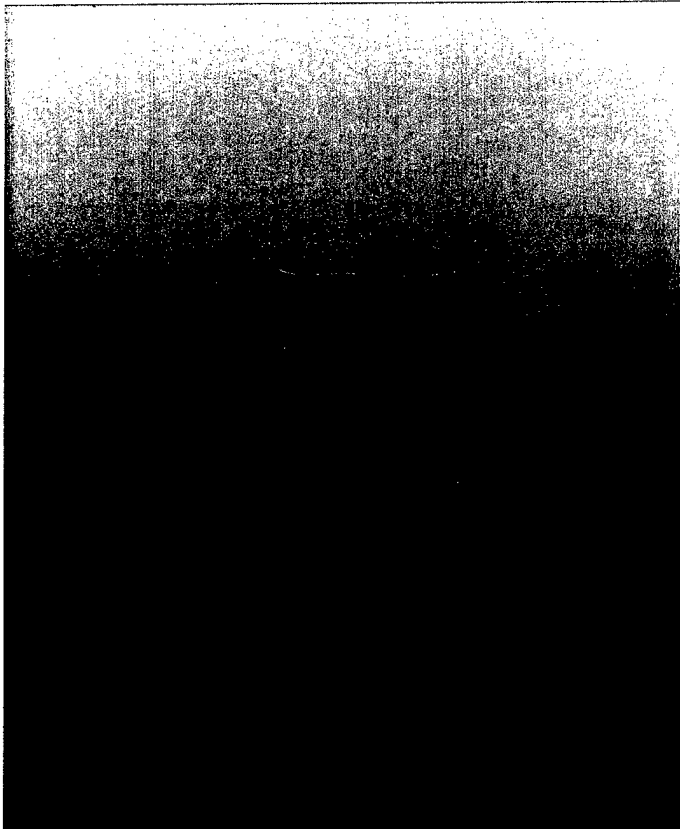

TR 1751  
July 1997

Approved for public  
release; distribution  
is unlimited.