

REPORT DOCUMENTATION PAGE

Form Approved
OMB No. 0704-0188

Public reporting burden for this collection of information is estimated to average 1 hour per response, including the time for reviewing instructions, searching existing data sources, gathering and maintaining the data needed, and completing and reviewing the collection of information. Send comments regarding this burden estimate or any other aspect of this collection of information, including suggestions for reducing this burden to Washington Headquarters Service, Directorate for Information Operations and Reports, 1215 Jefferson Davis Highway, Suite 1204, Arlington, VA 22202-4302, and to the Office of Management and Budget, Paperwork Reduction Project (0704-0188), Washington, DC 20503

1. AGENCY USE ONLY (Leave Blank)	2. REPORT DATE 7/31/97	3. REPORT TYPE AND DATES COVERED Annual Tech. 8/1/96 - 7/31/97	
4. TITLE AND SUBTITLE Annual Technical Report: Control of Sludge Destruction in Shipboard Incineration		5. FUNDING NUMBERS G-N00014-96-1-1196	
6. AUTHOR(S) Ben T. Zinn and Lawrence M. Matta		8. PERFORMING ORGANIZATION REPORT NUMBER	
7. PERFORMING ORGANIZATION NAME(S) AND ADDRESS(ES) Georgia Institute of Technology School of Aerospace Engineering Atlanta, GA 30332-0150		9. SPONSORING/MONITORING AGENCY NAME(S) AND ADDRESS(ES) Office of Naval Research Ballston Center Tower One 800 North Quincy Street Arlington, VA 22217-5660	
11. SUPPLEMENTARY NOTES COR:			
12a. DISTRIBUTION/AVAILABILITY STATEMENT Approved for Public Release		12b. DISTRIBUTION CODE	
13. ABSTRACT (Maximum 200 words) <p>The goal of this project is the development of a novel, actively controlled, shipboard sludge incinerator using state of the art pulsating combustion technology. This study is aimed at determining the feasibility of such an incinerator, developing the technology to construct a suitable pulse combustor for exciting high amplitude velocity oscillations in the incinerator, and examining the benefits obtained from this technology. Two approaches have been taken towards the development of a suitable pulse combustor. First is the development of a tunable pulse combustor that can force resonant oscillations in the incinerator chamber. The second approach is to develop a high amplitude, low frequency pulse combustor that can generate bulk mode type pulsating flow in the incinerator chamber. Two tunable pulse combustors have been developed for testing; one is mechanically tuned, the other is a novel, electronically tuned pulse combustor designed to be used in conjunction with a previously developed fuel modulation system. While both systems show some promise for use in the sludge incinerator, they currently have shortcomings, such as their inability to operate on liquid fuels. A single frequency, aerodynamically valved, oil burning pulse combustor was also constructed. While this burner burns liquid fuel and produces high amplitude pulsations, it is not tunable, and therefore, oscillations forced in the incinerator are not resonant. Improvement and testing of these systems will be continued under this project. Also, tests have been performed to show that the two-phase atomizer currently used to spray sludge into the incinerator chamber may be replaced by injecting a stream of sludge into the exhaust of the pulse combustor for atomization.</p>			
14. SUBJECT TERMS Incineration, pulse combustion acoustic driving		15. NUMBER OF PAGES 28	
17. SECURITY CLASSIFICATION OF REPORT Unclassified		16. PRICE CODE	
18. SECURITY CLASSIFICATION OF THIS PAGE		19. SECURITY CLASSIFICATION OF ABSTRACT	
20. LIMITATION OF ABSTRACT		21. LIMITATION OF ABSTRACT	

Annual Technical Report:
Control of Sludge Destruction in Shipboard Incinerators
ONR Grant No. N00014-96-1-1196
July 31, 1997

Prepared For:

Office of Naval Research

Contract Monitor:

Dr. Klaus Shadow

Prepared By:

Ben T. Zinn and Lawrence M. Matta

DTIC QUALITY INSPECTED 3

**School of Aerospace Engineering
Georgia Institute of Technology
Atlanta, GA 30332**

19970804 072

Abstract

The goal of this project is the development of a novel, actively controlled, shipboard sludge incinerator using state of the art pulsating combustion technology. This study is aimed at determining the feasibility of such an incinerator, developing the technology to construct a suitable pulse combustor for exciting high amplitude velocity oscillations in the incinerator, and examining the benefits obtained from this technology. Two approaches have been taken towards the development of a suitable pulse combustor. First is the development of a tunable pulse combustor that can force resonant oscillations in the incinerator chamber. The second approach is to develop a high amplitude, low frequency pulse combustor that can generate bulk mode type pulsating flow in the incinerator chamber. Two tunable pulse combustors have been developed for testing; one is mechanically tuned, the other is a novel, electronically tuned pulse combustor designed be used in conjunction with a previously developed fuel modulation system. While both systems show some promise for use in the sludge incinerator, they currently have shortcomings, such as their inability to operate on liquid fuels. A single frequency, aerodynamically valved, oil burning pulse combustor was also constructed. While this burner burns liquid fuel and produces high amplitude pulsations, it is not tunable, and therefore, oscillations forced in the incinerator are not resonant. Improvement and testing of these systems will be continued under this project. Also, tests have been performed to show that the two-phase atomizer currently used to spray sludge into the incinerator chamber may be replaced by injecting a stream of sludge into the exhaust of the pulse combustor for atomization.

Introduction

The objective of this program is to investigate the feasibility and benefits of a novel shipboard sludge incinerator using pulsating combustion technology. Shipboard sludge incinerators are currently being used by the Navy to incinerate black water consisting of five percent organic matter and ninety five percent water. In the future, the percentage of water in the sludge will be reduced by use of membranes, and oils will be added to the remaining sludge prior to its incineration. The Navy plans to incinerate this sludge in a modified version of its current shipboard sludge incinerator, see Fig. 1, and is seeking technologies that will increase the throughput of its sludge incinerators while minimizing emissions of hazardous pollutants. Recent studies have indicated that this could be accomplished by actively controlling the incineration process with acoustic excitation^{1,2}. This study will investigate the feasibility and performance of a actively controlled, pulsating sludge incinerator that aims to simplify current shipboard incinerator design, increase its maximum sludge throughput, reduce emissions and lower fuel consumption.

It has been demonstrated that the presence of acoustic oscillations and flow pulsations can increase the rates of transport processes. Patera et. al.,^{3,4} for example, have shown that mixing and heat transfer rates of laminar flow in a channel can be considerably increased by destabilizing the shear layer using flow oscillations at properly chosen frequencies. There has been considerable evidence that mass⁵ and heat^{6,7,8} transfer rates are increased by acoustic oscillations. While the mechanisms responsible for these increases are not entirely understood, evidence^{6,9} suggests that the increased transport rates are due to the excitation of turbulence and vortical structures by the acoustic oscillations. Vermeulen et al.¹⁰ showed that flow oscillations reduce flow stratification and improve mixing, which can result in the elimination of localized pockets of high temperature gas, or "hot spots", in a combustor. Rapid mixing is critical in liquid waste incinerators because evaporating droplets of waste generate fuel rich regions in the incinerator, which can result in the emission of soot, CO, and unburned hydrocarbons if proper mixing and combustion do not occur rapidly. Also, "hot spots" may be the cause of increased thermal nitrogen oxide production by the Zeldovich mechanism.

Several investigations of pulse combustors suggest that when combustion occurs in an oscillatory flow field, the combustion time is reduced and combustion efficiencies are increased with respect to combustion in a steady flow field. Lyman¹¹ for example, showed that pulsations increased the burning rates of individual coal particles, and Zinn et al.¹² found that unpulverized coal nuggets can be burned in a Rijke type pulse combustor with high combustion efficiency while utilizing little excess air. Bai¹³ showed that heavy fuel oils, which are generally difficult to burn, can be burned with high combustion efficiencies in a pulse combustor specifically designed for this purpose.

The interaction between a stream of sludge and the large amplitude velocity oscillations in the exhaust flow of a pulse combustor will be used to atomize the sludge and produce a spray that will readily evaporate and burn. Since the sludge will be atomized by the pulsating stream of hot combustion products, evaporation of the generated droplets and combustion of their organic constituents will start simultaneously with their atomization. The exhaust flow of the pulse combustor will entrain the generated droplets and set them into a swirling motion within the incinerator volume, thus increasing their dispersion and residence time within the incinerator. The

use of the pulse combustor to atomize the sludge will eliminate the need for a separate two-fluid atomizer that is currently used to atomize the sludge. A similar approach has been successfully used by Bepex¹⁴ to spray dry various foods and pharmaceuticals. In the Bepex pulse dryer, the sludge is injected directly into the exhaust flow of a pulse combustor where it is atomized, heated and partially vaporized. The resulting mixture of gases, droplets and partially dried particles is transported into a large dryer volume, where the drying process is completed in a pulsating environment. The dried material is separated from the flow and collected in the exhaust system. A sludge incinerator is similar to a spray dryer, except that enough energy must be added to the sludge to not only dry it, but to ignite and burn its combustible content.

Progress

Efforts in the first year of this project have been primarily directed toward developing a pulse combustor capable of exciting large amplitude velocity oscillations in the shipboard sludge incinerator under typical operating conditions. In order to excite the first transverse resonant acoustic mode in the incinerator, calculations predict that the combustor must be able to pulse at approximately 650Hz. Higher frequencies are required to excite higher acoustic modes and combined longitudinal and transverse modes. Currently existing pulse combustors typically operate below 500Hz. One technique, then, for exciting high amplitude velocity oscillations in the incinerator is to develop a tunable pulse combustor that can be tuned to one of these high frequencies while providing the heating rates necessary for sludge incineration. Another technique is to drive large amplitude velocity oscillations below the fundamental frequency with enough force to generate a bulk mode pulsating type flow. In this reporting period, both of these approaches have been investigated, and the results are discussed below. Also, some research has been performed to determine whether the oscillatory flow at the exit of a pulse combustor can be used as an atomizer for the waste in a liquid incinerator. The results of these tests are also discussed below.

Development of a Tunable Pulse Combustor

Three operational approaches were considered in the development of the pulse combustor: mechanically tunable, electronically controlled, and a combination of electronic and mechanical tuning. To ensure that a usable combustor would be developed, both mechanically tuned and electronically controlled approaches were simultaneously followed. Currently, natural gas fired combustors are being tested.

Testing with a previously constructed, mechanically tuned pulse combustor with a power rating of 0.6 MMBtu/hr indicated that the maximum pulsing frequency of this combustor was approximately 430Hz. Sivasigaram and Whitelaw¹⁵ have suggested that the maximum pulsing frequency of a flame holder-type combustor is dependent on the diameter of the combustor. Using Sivasigaram and Whitelaw's empirical relations, a mechanically tunable pulse combustor was developed with a smaller diameter, and a corresponding reduction in capacity. Schematics of the small, mechanically tunable pulse combustor and the model incinerator with the combustor attached are presented in Fig. 2. This newly developed pulse combustor has been shown to

operate at up to 950Hz, which is well above the minimum frequency required to drive resonant acoustic oscillations in the chamber of the shipboard sludge incinerator. Unfortunately, the power capacity was reduced to 170 MBTU/hr, which is much lower than the 1MMBtu/hr power of the steady oil burner used with the current generation sludge incineration system. In order to make use of such a combustor, it would either have to be used in conjunction with a steady state burner that provided the balance of the necessary heat input to the incinerator, or multiple pulse combustors would need to be used. A graph of the pressure oscillation amplitude excited in the incinerator chamber for various flame holder positions in the combustor is shown in Fig. 3. The figure shows that even operating at a low heat output, the burner can excite resonant oscillations on the order of 155dB in the chamber. Figure 4 shows how the pressure amplitude of the second longitudinal/first tangential combined resonant mode varies with the heat output of the combustor. As expected, the acoustic amplitude increases with combustor power, but the functional relationship is not currently understood.

A novel pulse combustor that can be used in conjunction with a previously developed fuel actuator system was designed and constructed. This burner is referred to as the Pulsed Flame Tube Driver (PFTD). The concept of the PFTD is that a compact combustor mounted to the wall of the incinerator chamber would, in the absence of forced fuel modulation, couple acoustically to pressure oscillations in the chamber, and the resulting feedback loop would cause the system to resonate. A schematic of the PFTD configured without the actuator is shown in Fig. 5. The fuel injector actuator, together with appropriate control software, provides a secondary stream of modulated fuel to the combustor at frequencies and phases determined in real-time from sensor measurements so that the mode and amplitude of the oscillations can be selected by the operator. The configuration of the PFTD with the secondary fuel injector and the actuator present is shown in Fig. 6.

The performance of the PFTD without secondary fuel modulation was tested in two configurations. In the first configuration, shown in Fig. 7A, the PTFD was mounted on the side of the incinerator chamber in a position similar to the mounting of the current steady burner used on the shipboard incinerator. It was expected that in this position, coupling would be achieved with either a transverse mode of the chamber or with a three-dimensional combination of a longitudinal mode with a transverse mode. The natural gas supply rate was varied from 50 to 350 MBtu/hr, the flame-holder location varied over its full range, and the equivalence ratio was varied from 1 to lean blow-off. Under no conditions was the burner spontaneously unstable, which means that the expected feedback loop did not occur.

In the second configuration tested, shown in Fig. 7B, the PFTD was mounted on the upstream end of the incinerator chamber, coaxially. In this configuration, if coupling were to occur, it was expected to be with a longitudinal mode of the chamber, since the frequencies of the radial modes are quite high, and the radially symmetric geometry does not favor the excitation of transverse modes. If the PFTD coupled with a longitudinal mode, this would lead us to suspect that there was some geometrical difficulty coupling with the tangential modes. The same range of parameters from the previous configuration was tested. In this configuration, when the heat input was greater than 300 MBtu/hr, the equivalence ratio less than 0.8, and the flame-holder was pulled back to give very high velocities, the system pulsed at 1270Hz at low amplitude (135dB). This frequency corresponds to a quarter wave oscillation in the PFTD itself, and is approximately the same as the seventh longitudinal mode of the chamber. While this oscillation does show

coupling in the system, it is not behaving as designed, but instead as a single frequency device. It is believed that the reason this mode was not seen in the previous configuration is that the frequency did not correspond to any mode that could be driven in the tank from where the burner was located.

The actuator was added to the PFTD to provide fuel modulation without the necessity of natural feedback. In order to separate the effects of the modulated fuel flow supplied by the actuator from the effects of pressure feedback on the air and primary fuel lines, the air and primary fuel inlets were choked for tests involving the actuated PFTD. When the actuated PFTD was mounted to the side of the incinerator chamber, configuration A, the fundamental longitudinal mode could be excited at low amplitude. No higher frequencies or transverse modes could be excited.

Possible explanations for the inability of the PFTD to provide significant acoustic driving in the above described test are:

- 1) the oscillatory flame does not couple with the pressure oscillations in the model incinerator
- 2) inability to produce an oscillating flame due to:
 - a) the fuel injector actuator not providing an oscillatory fuel flow rate, or
 - b) fuel flow rate oscillations are being fluid mechanically dissipated, or smeared out, before entering the combustion zone

In order to address item 1, analytical as well as experimental studies are being performed in an attempt to determine whether there is any acoustic reason that a compact oscillatory flame would not be able to drive a relatively large volume cavity. In order to determine whether the PFTD is capable of coupling with a resonator more typical of common pulse combustors, the burner was mounted to several 4 in. IPS pipes, 65 in., 51 in., and 18 in. long. When attached to these pipe sections, oscillations occurred over a large range of fuel flow rates, equivalence ratios, and flame holder positions. These oscillations were at approximately 82Hz, 100Hz., and 250Hz, respectively, which corresponds to quarter wave, organ pipe oscillations in the PTFD/pipe combinations. In each case, the amplitude of oscillation was approximately 170dB in the PFTD. A graph showing the autospectra of the pressure measured inside the PFTD when it was attached to the 51 in. pipe for several tests is presented in Fig. 8. The PFTD concept has been proven by these tests to work in relatively small diameter pipes. It has been demonstrated that if the PFTD is located at the end of a resonating tube, it can drive high amplitude oscillations within the resonator. The driver and the resonating tube (essentially a pulse combustor) can then be coupled to a larger chamber, and oscillations are driven in the chamber at a lower amplitude than that in the PFTD resonator. The intention of the PFTD was, however, to do away with the resonating pipe and use the chamber itself as the resonator. Tests using speakers mounted on resonating tubes and directly to the wall of the model incinerator have shown that using a resonator allows higher amplitudes to be driven using the same input power to the speaker. It is hoped that the analytical and numerical investigations will provide some insights into the physics of this problem.

To investigate the second item above, tests were performed with the actuated PFTD mounted on an 18 in. long, 4 in. IPS pipe section. The PFTD primary fuel and air inlets were choked to prevent a natural instability. In the original design configuration of the fuel injector, when 80% of the fuel was supplied through the primary fuel inlet and 20% of the fuel flow was modulated through the secondary fuel inlet, and the average equivalence ratio varied from 1 to lean blow-off, no significant oscillations were measured at any frequency. The conditions were then modified so that all the fuel was injected through the secondary injector, and the amplitude of modulation was 60% of the total fuel flow rate. The average equivalence ratio was set to 0.75, so that the instantaneous equivalence ratio varied from 0.3 to 1.2. With this extremely large fuel modulation, an oscillation could be driven a 250 Hz., the quarter wave mode, with a measured amplitude of 150 dB. in the PFTD. This is an order of magnitude less than could be achieved without the actuator (by a spontaneous instability) when the air and primary fuel lines were not choked.

Because the unchoked PFTD can be spontaneously unstable in this configuration, the lack of pulsations was apparently not due to an inability of the combustion process to couple with the acoustic oscillations. The results of these tests did not show, however, whether the inability to drive oscillations was due to mixing of the secondary fuel oscillations before reacting or the inability of the actuator to provide a modulated fuel flow rate. To resolve this question, hot-wire anemometry was used to measure the flow rate of air modulated by the fuel injector actuator. This test showed that fuel injector actuator was performing as expected, and that the modulation amplitude was practically independent of frequency from 20 Hz. to over 1000 Hz. Therefore, the inability to drive oscillations in this configuration must be due to the smearing out of the secondary fuel oscillations before reaching the flame zone.

To test this conclusion, the secondary fuel injector was extended 1.5 in. downstream, so that the modulated fuel flow rate was injected closer to the flame zone. In addition, a detection system was added to measure the CH chemiluminescence of the flame, so that the reaction rate could be correlated with the displacement of the fuel actuator. The phase between the actuator displacement and the radiation gives an indication of the time delay between the fuel injection and the consumption of the injected fuel by the flame. Using the modified fuel injector and closed-loop active control, an oscillation with an amplitude of 164 dB. at 265 Hz. could be excited in the PFTD. The acoustic pressure spectrum measured using closed loop control is shown in Fig. 9. In this study, 25% of the fuel was introduced through the secondary fuel injector actuator, but only a 40% modulation amplitude was used (in other words, the modulation amplitude was approximately 10% of the total fuel flow rate). While this represents a factor of 5 increase over the pressure amplitude achieved with the previous fuel injector, it is still rather low. The flame would not stay ignited at higher modulation amplitudes.

It has been demonstrated that the use of secondary fuel injection at off-resonant frequencies can drive low amplitude oscillations at the injection frequency. Figure 10 shows the frequency spectrum of the acoustic pressure in the PFTD, attached to an 18" long pipe, with secondary fuel addition occurring at 220 Hz. The frequency corresponding to a quarter wave mode is approximately 300 Hz. in this case. The pressure amplitude excited by the fuel modulation in this example is 150dB. The radiation measurements show that oscillatory combustion is occurring at the fuel modulation frequency. This suggests that the sound is not simply being generated by the flow through the secondary fuel injector, as if it were a siren, but is

actually being driven by the oscillatory combustion process. Phase measurements between the actuator displacement and the radiation show that, even with the increased injector length, the time delay between when the fuel is injected and when it is reacted is relatively large, indicating that item 2b above is at least partially to blame for the weak driving. Therefore, the injector will again be extended, so that the secondary fuel can be delivered as close as possible to the reaction zone. It has also been observed that the relationship between the phase delay and the frequency is not linear. This means that the phase between the secondary fuel injection and the reaction of the secondary fuel is not purely based on a convection time delay. This phenomenon is being investigated further.

In summary, modification of the secondary fuel injector actuator used with the PFTD and the secondary fuel actuator has resulted in a 5X increase in the acoustic pressure amplitude that can be excited in a resonating tube, and testing has provided insight as to why this increase occurred. An attempt to increase the current amplitude of 164 dB through further modifications is underway. If the modifications result in a further increase in performance, the primary fuel and air lines will be unchoked, and the closed-loop control system will be used to enhance the natural instability of the PFTD, and to attach the system to the model incinerator to determine whether the modified PFTD is capable of driving high amplitude oscillations in the incinerator chamber without the use of a secondary resonating tube.

Development of a Low Frequency Pulse Combustor

The second approach taken to providing large amplitude velocity oscillations in the shipboard incinerator was the use of a low frequency pulse combustor to force bulk type pulsations in the chamber. To provide this driving, research has been directed toward developing an oil burning pulse combustor suitable for application on a shipboard incinerator that is independent of the fuel actuator and the PFTD.

A single frequency, aerodynamically valved, oil burning pulse combustor has been constructed. An illustration of the burner section is shown in Fig. 11. A resonating tailpipe must be attached to the exhaust port to support the pulsations. The prototype is capable of burning 750 MBtu/hr of kerosene type fuel oils, such as JP5. With minor design changes, a burner that can operate at over 1 MMBtu/hr can be readily constructed. As presently configured, the combustor operates at 80 Hz, and when burning 650 MBtu/hr, has an acoustic pressure amplitude of 1.5 PSI RMS, or 174 dB. Testing to determine the operating characteristic of this combustor are currently underway so that flame safety systems, startup and shutdown control systems, and an air-cooling/secondary air preheating system can be developed.

The main question to be addressed with this type of combustor is how it will affect the processes occurring in the incinerator. Since this combustor operates at a fixed frequency, a resonance condition will not be established in the incinerator chamber, because the frequency of the pulse combustor is low compared to the resonance frequencies of the incinerator. It is expected, however, that the incinerator will experience a bulk mode type of pulsations. Testing during the next reporting period will determine the amplitudes of the pressure and velocity fluctuations that can be established in the model incinerator. An investigation will also be initiated to determine the effect such pulsations upon incineration processes.

Atomization Using A Pulse Combustor

It is believed that injection of the sludge into the hot, oscillating flow of the pulse combustor exhaust will provide high quality atomization of the sludge, so that the currently used, two-fluid atomizer will no longer be necessary. The second advantage of using the pulse combustor to atomize the sludge is that, since the sludge is delivered directly into the hot, oscillating exhaust gas, extremely rapid heat transfer will take place between the gas and liquid phase.

To test the ability of pulse combustor exhaust to atomize a stream of liquid, the small mechanically tunable pulse combustor developed earlier in this program was fitted with two removable liquid injectors near the end of the tailpipe, one radial and one coaxial with the exhaust gas flow. This combustor was chosen for these tests because it can easily be operated at the same fuel and air input rates with and without pulsations, simply by varying the flame holder and nozzle locations. A schematic of the atomization setup is shown in Fig. 12. In order to determine the effect of the pulsations on atomization, tests were performed with the combustor operating at 150 MBtu/hr with and without pulsations for various flow rates of water through the injectors. When pulsations were present, the pulse combustor was operated at about 600Hz and at an acoustic amplitude of 170dB at the flame holder. The tests were photographed digitally, and downloaded to a computer for processing. An average image was generated from 8 instantaneous images for each flow condition, and then the spreading angles of the generated sprays were measured from the images to give an indication of atomization efficiency. Figure 13 shows example images of the radially directed injection with and without pulsations, and Fig. 14 shows examples of the coaxially injected spray, with measurements used in the spreading angle calculations shown. It is clear from these pictures that the spreading rate of the spray is greatly increased by the presence of pulsations in the exhaust flow. The measured spreading angles for different water injection rates with and without pulsations present are shown in Fig. 15. The percentage change in spreading angle is also shown. While an increase in spreading angle does not directly correlate to faster heat exchange between the spray and the hot exhaust gas, it is logical that in order to disperse in a shorter distance the spray must be entraining more of the hot gases. Much more detailed work can be performed on this subject, such as droplet size comparisons, in the future, if interest exists.

Summary and Conclusions

The objective of this program is to investigate the feasibility and benefits of a novel shipboard sludge incinerator using pulsating combustion technology. The Navy is seeking technologies that will increase the throughput of its sludge incinerators while minimizing emissions of hazardous pollutants. This project is part of a Navy sponsored program with the goal of developing a actively controlled, pulsating sludge incinerator that aims to simplify current shipboard incinerator design, increase its maximum sludge throughput, reduce emissions and lower fuel consumption.

The first year of this project has been primarily directed toward developing a pulse combustor capable of exciting large amplitude velocity oscillations in the shipboard sludge incinerator. Two approaches have been taken toward this goal. First is the development of a tunable pulse combustor that can be tuned to excite resonant oscillations in the incinerator chamber. The second approach is to develop a high amplitude, low frequency pulse combustor that can be used to generate a non-acoustic, bulk mode type pulsating flow in the incinerator chamber.

Two separate techniques have been used in the development of a tunable pulse combustor. In order to show that technology exists to create a mechanically tuned pulse combustor for this application, a natural gas fired, mechanically tuned pulse combustor was constructed. The combustor provides a strong sound source and is capable of operating in the frequency range of the incinerator chamber; however, a number of problems are associated with this design. First, it does not operate on liquid fuels. For a number of reasons, no simple solution to this problem exists. Second, in order to achieve the high frequencies necessary to excite resonant acoustic oscillations in the incinerator chamber, the mechanically tunable pulse combustor is limited to 200MBtu/hr power. Third, the mechanical tuning makes control somewhat difficult in this type of combustors.

A novel pulse combustor that can be used in conjunction with a previously developed fuel actuator system was designed and constructed. It's concept is that a compact combustor mounted to the wall of the incinerator chamber would, in the absence of forced fuel modulation, couple acoustically to pressure oscillations in the chamber, and the resulting feedback loop would cause the system to resonate. The fuel injector actuator, together with appropriate control software, provides a secondary stream of modulated fuel to the combustor at frequencies and phases determined in real-time from sensor measurements so that the mode and amplitude of the oscillations can be selected by the operator. While some of the basic mechanisms of this combustor have been demonstrated, the overall performance of this combustor is currently inadequate, and much effort has been expended to understand its operation. Research into improving this combustor is underway. Also, this combustor must be modified to operate on liquid fuels.

The second approach taken to providing large amplitude velocity oscillations in the shipboard incinerator was the use of a low frequency pulse combustor to force bulk type pulsations in the chamber. During the period of this report, a single frequency, aerodynamically valved, oil burning pulse combustor has been constructed. The prototype is capable of burning 750 MBtu/hr of kerosene type fuel oils, such as JP5. With minor design changes, a burner that can operate at over 1 MMBtu/hr can be readily constructed. As presently configured, the combustor operates at 80 Hz, and when burning 650 MBtu/hr, has an acoustic pressure amplitude of 1.5 PSI RMS, or 174 dB. Testing to determine the operating characteristic of this combustor are currently underway. Still to be determined with this type of combustor is how it will affect the processes occurring in the incinerator.

The exhaust of a pulse combustor has been demonstrated to atomize a stream of water with a flow rate equal to that of the current sludge atomizer. The spreading angle of the generated spray was shown to be greater when pulsations were present than when the flow was steady.

References

- 1) Gutmark, E., Wilson, K. J., Parr, T. P., Smith and Schadow, "Actively Controlled Incinerator With Vortex Combustion", AIAA-96-0670, 34th Aerospace Sciences Meeting, Reno, Nevada, January, 1996.
- 2) Stewart, C. R., Lemieux, P. M. and Zinn, B. T., "Application of Pulse Combustion to Solid and Hazardous Waste Incineration", Proc. Int. Symp. on Pulse Combustion, Aug. 6-8, 1991, Monterey, California.
- 3) Patera, A. T. and Mikic, B. B., "Exploiting Hydrodynamic Instabilities: Resonant Heat Transfer Enhancement", Int. J. Heat Mass Transfer, Vol. 29, No. 8, pp. 1127-1138, 1986.
- 4) Ghaddar, N. K., Magen, M., Mikic, B. B., and Patera, A. T., "Numerical Investigations of Incompressible Flow in Grooved Channels, Part 2: Resonance and Oscillatory Heat-Transfer Enhancement", J. Fluid Mech., Vol. 168, pp. 541-567, 1986.
- 5) Hodgins, J. W., Hoffman, T. W., and Pei, D. C., "The Effect of Sonic Energy on Mass Transfer in Solid-Gas Contacting Operations", Canadian J. of Chem. Eng., pp. 18-24, June 1957.
- 6) Deck, J. E., Arpaci, V. S., and Keller, J. O., "Heat Transfer in the Oscillating Turbulent Flow of Pulse Combustor Tail Pipes", Final Report, Sandia Combustion Laboratories, GRI Contract No. 5084-260-1092, July 1989.
- 7) Hanby, V. I., "Convective Heat Transfer in a Gas-Fired Pulsating Combustor", Trans. ASME J. of Eng. for Power, No. 1, pp. 48-51, January 1969.
- 8) Arpaci, V. S., Dec, J. E., and Keller, J. O., "Heat Transfer in Pulse Combustor Tailpipes", Proceed. of Int. Symposium on Pulsating Combustion, Sponsored by Sandia National Laboratories and the Gas Research Institute, Monterey, CA, August 1991.
- 9) Merkli, P. and Thomann, H., "Transition to Turbulence in Oscillating Pipe Flow", J. Fluid Mech., Vol. 68, Part 3, pp. 567-575, 1975.
- 10) Vermeulen, P. J., Odgers, J., and Ramesh, V., "Acoustic Control of Dilution-Air Mixing in a Gas Turbine Combustor", ASME J. of Eng. for Power, Vol. 104, No. 4, pp. 844-852, October 1982.
- 11) Lyman, F. A., and Sabnis, J. S., "Combustion of Captive Coal Particles in Pulsating Flow", Proceed. Symposium on Pulse Combustion Tech. for Heating Applications, ANL/EES-TM-87, pp. 95-104, Argonne National Laboratory, Argonne, IL, 1979.
- 12) Zinn, B. T., et al, "Development of a Coal Burning Pulsating Combustor for Industrial Power", DOE/ER/10068-T2, Pittsburgh Energy Tech. Center, Pittsburgh, PA, 1983.

- 13) Bai, T., "Combustion of Liquid Fuels in a Rijke Type Pulse Combustor", Ph.D. Thesis, Georgia Institute of Technology, Atlanta, GA 1992.
- 14) Ozer, R. W., "Pulse Combustion Drying", Proceedings of the Workshop on Pulsating Combustion and its Applications, Lund University, Lund, Sweden, 1993.
- 15) Sivasigaram, S. and Whitelaw, J. H., "Oscillations in Axisymmetric Dump Combustors", Comb. Sci. Tech., Vol. 52, pp. 413-426, 1987.

Tasks for Fiscal Year 1998

By 9/31/97-

Equip oil burning pulse combustor with automatic start-up/shut-down controls and flame safety system.

Determine sludge addition location that provides optimal atomization using the oil burning p/c.

By 11/31/97-

Implement combustor cooling and secondary air preheating system on the oil burning p/c.

By 12/31/97-

Optimize the controllable pulse combustor, which uses electronically modulated secondary fuel to generate pulsations, and determine whether this approach is practical for use in the shipboard sludge incinerator.

By 1/31/98-

Investigate how the incinerator chamber and the sludge injection affect the performance of the oil burning p/c, and modify the design and operation to improve performance if necessary.

By 4/31/98-

Determine the performance (maximum incineration rate, and efficiency) by varying sludge, fuel, and secondary air flow rates in the model incinerator using the oil burning p/c.

If the performance of the gas-fired, optimized, controllable pulse combustor is satisfactory:

Determine the effect of selected frequencies and amplitudes of excited oscillations upon the sludge incineration rate and incinerator emissions, and

Begin development and testing of a liquid fueled controllable pulse combustor.

By 7/31/98-

Analyze collected data and demonstrate the incinerator's performance using one or a combination of the investigated control approaches.

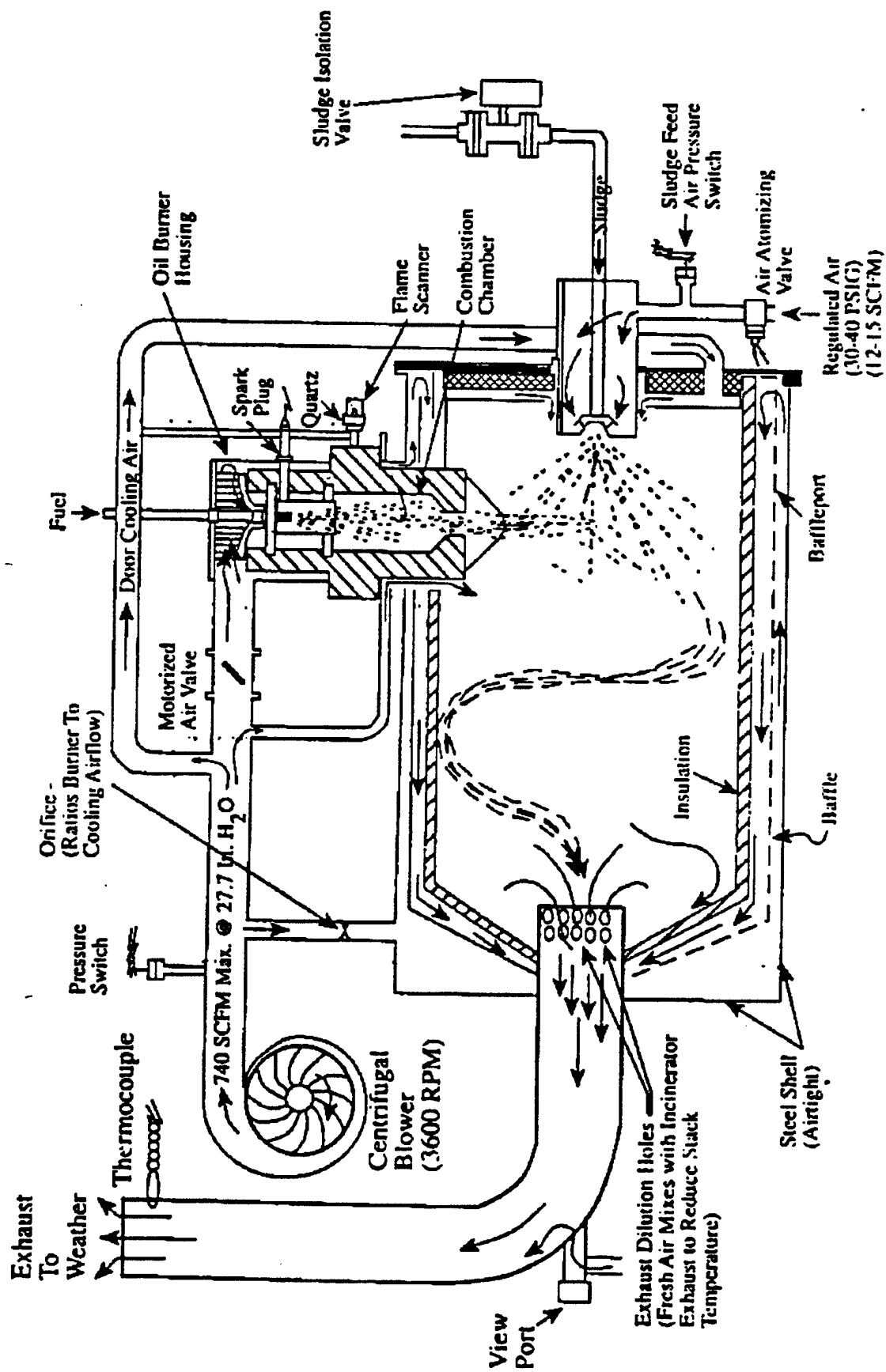
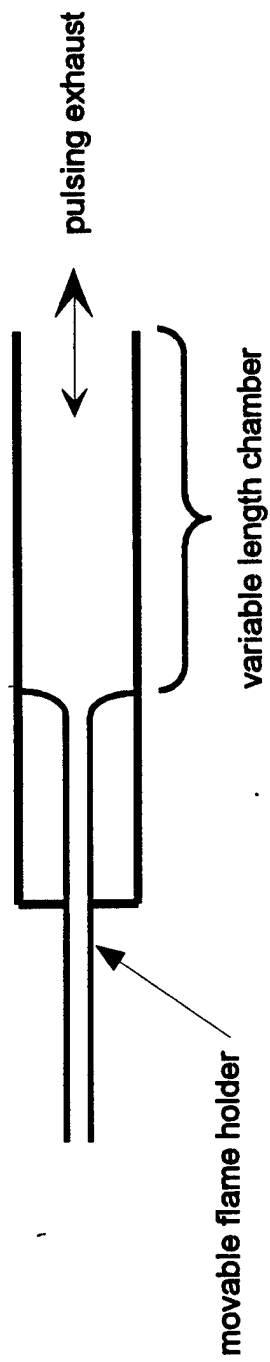
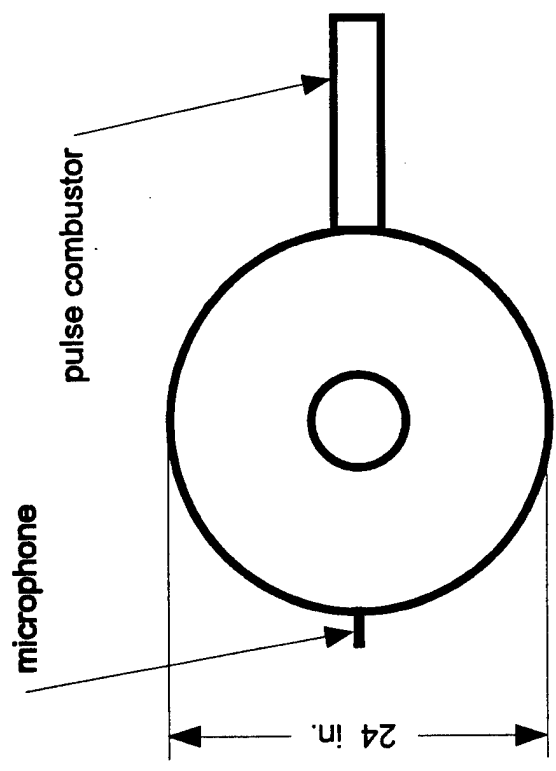

Figure 1. Schematic of the current shipboard sludge incinerator



a) Schematic of the Mechanically Tunable Pulse Combustor



b) Front view of the incinerator model with the mechanically tunable pulse combustor

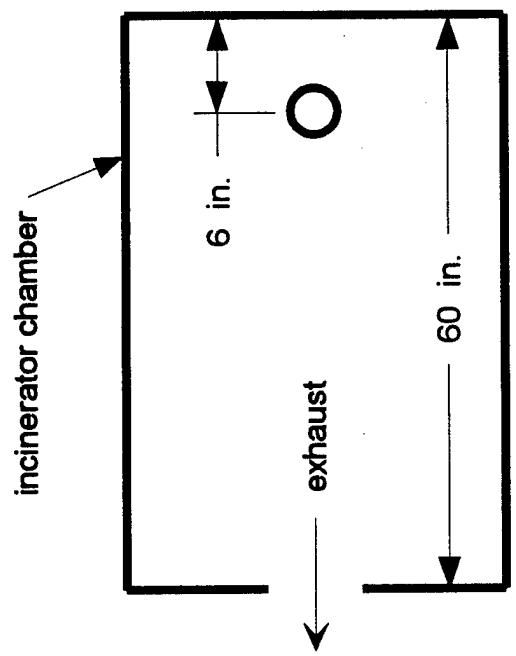

c) Front view of the incinerator model with the mechanically tunable pulse combustor

Figure 2. The mechanically tunable pulse combustor and the model incinerator

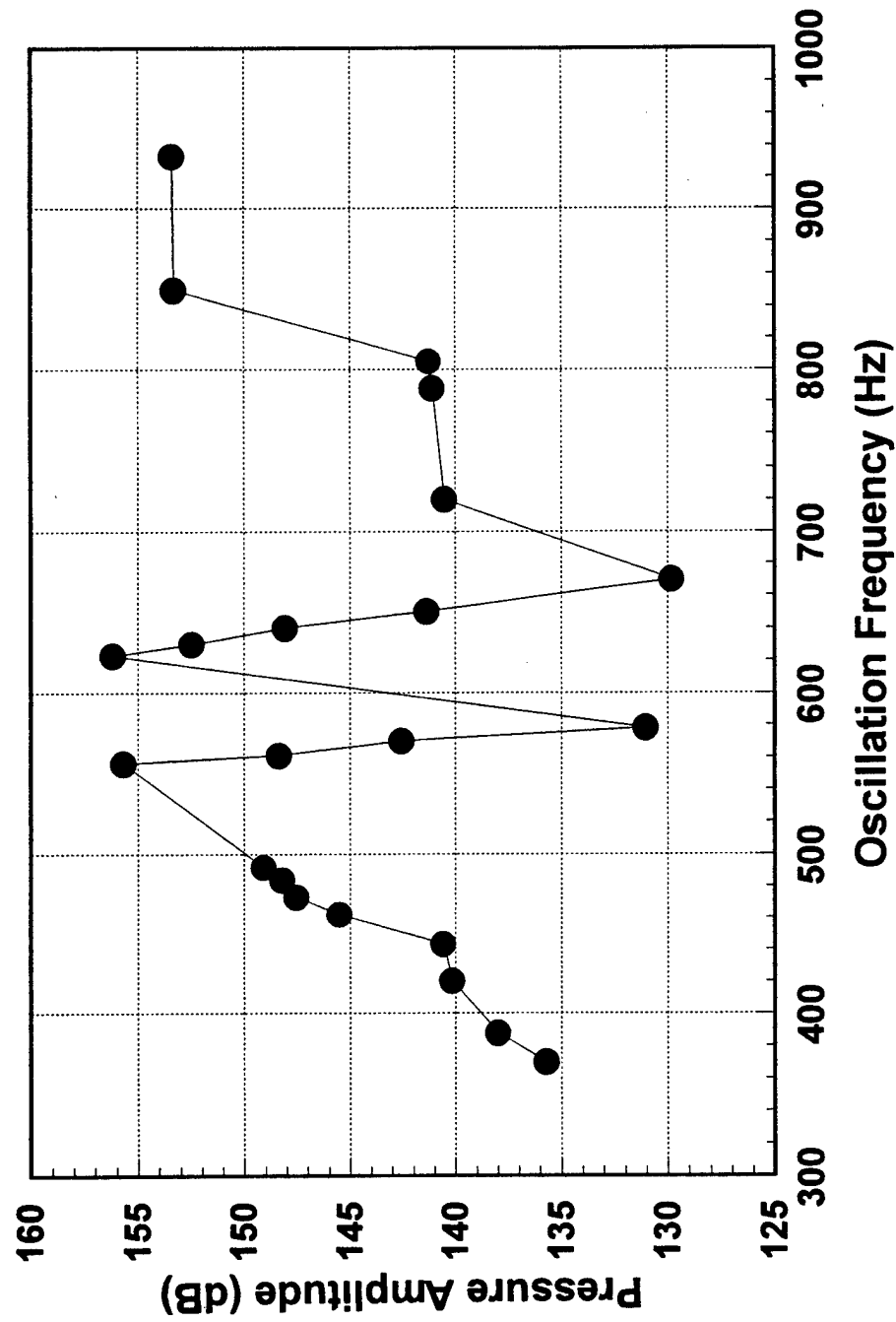

Figure 3. Pressure amplitudes excited in the model incinerator using the mechanically tunable pulse combustor

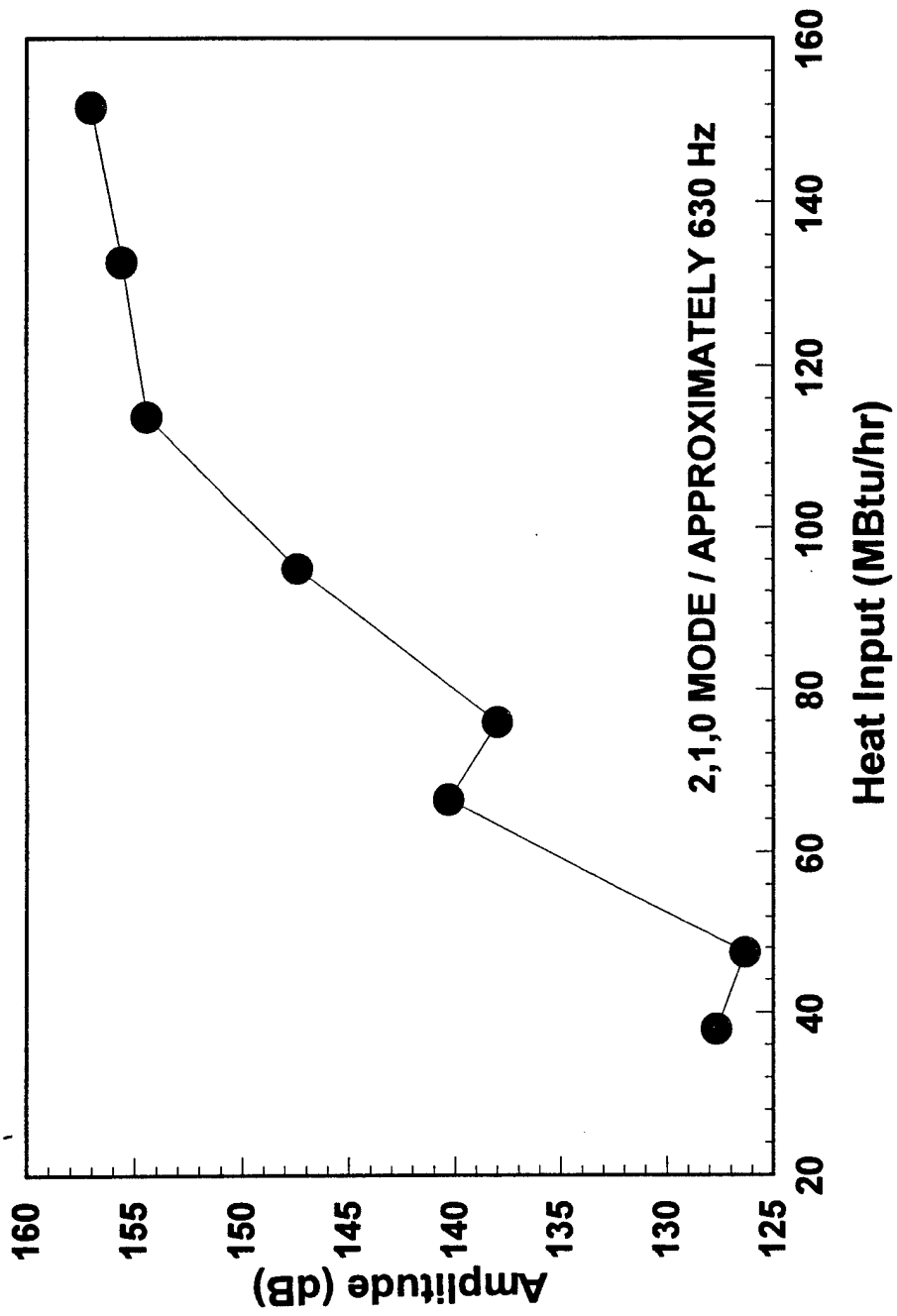

Figure 4. Correlation of amplitude in the incineration chamber to the fuel input of the mechanically tunable pulse combustor

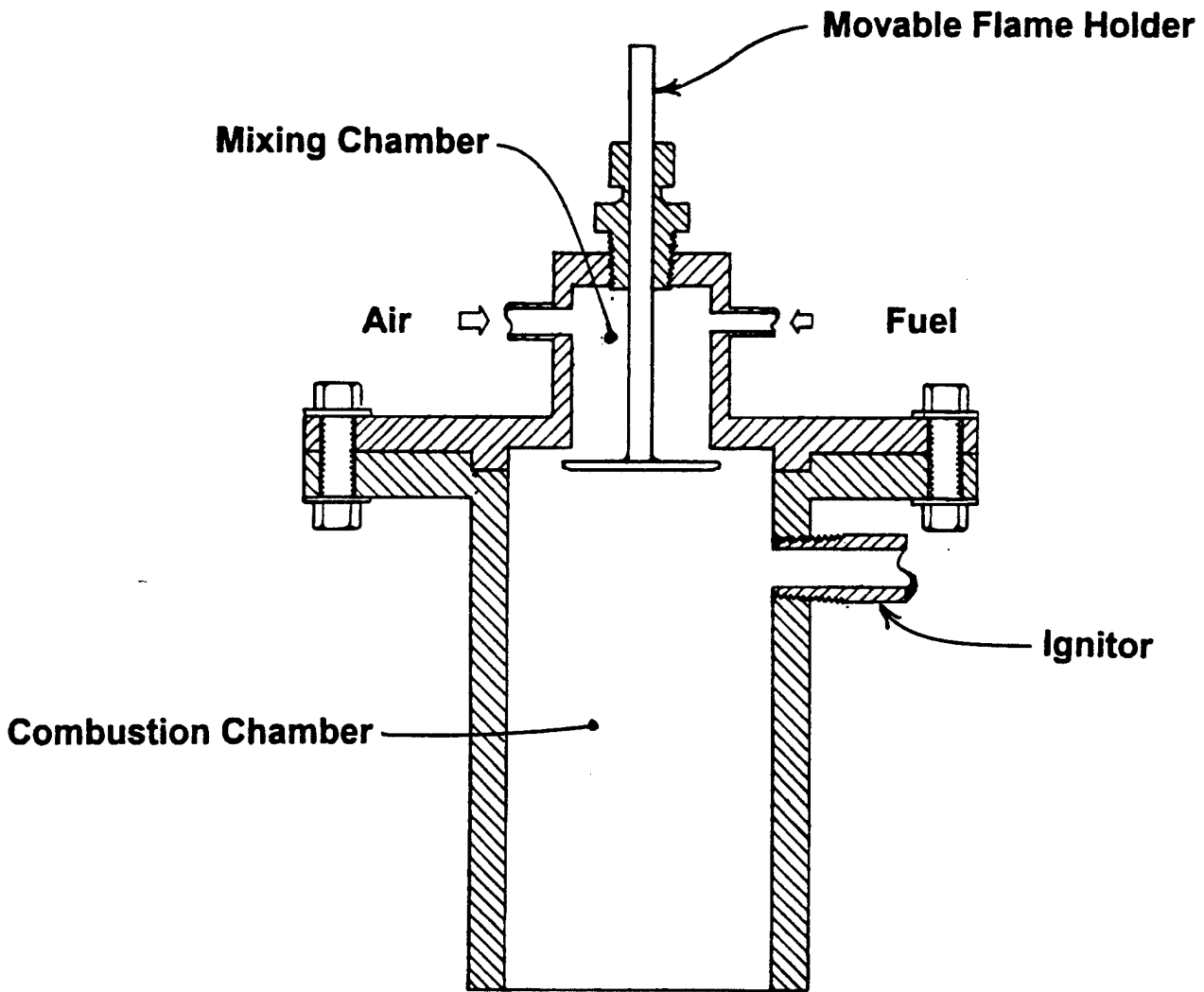

Figure 5. A schematic of the PFTD configured without the secondary fuel injector and actuator

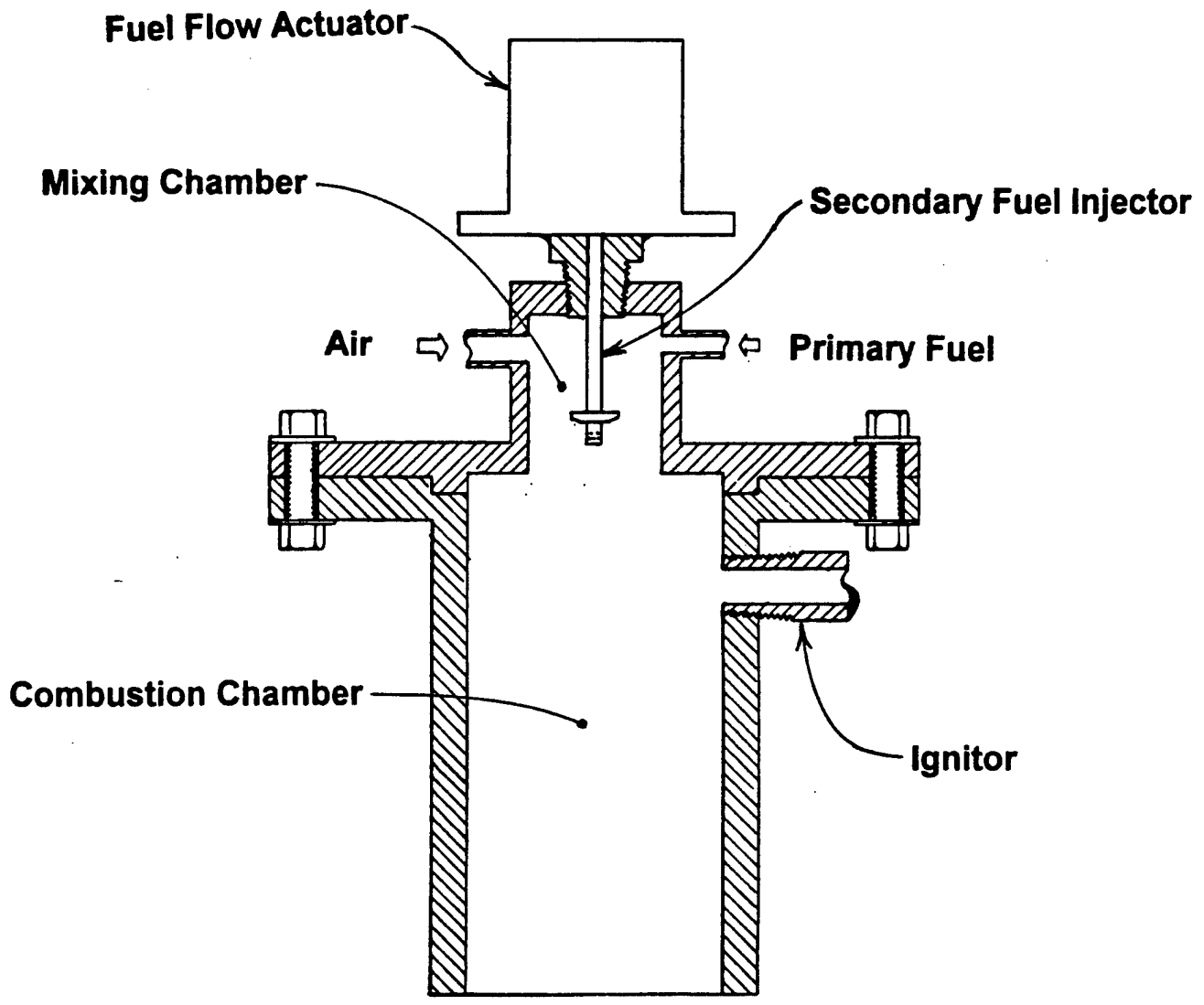

Figure 6. A schematic of the PFTD configured with the secondary fuel injector and actuator installed

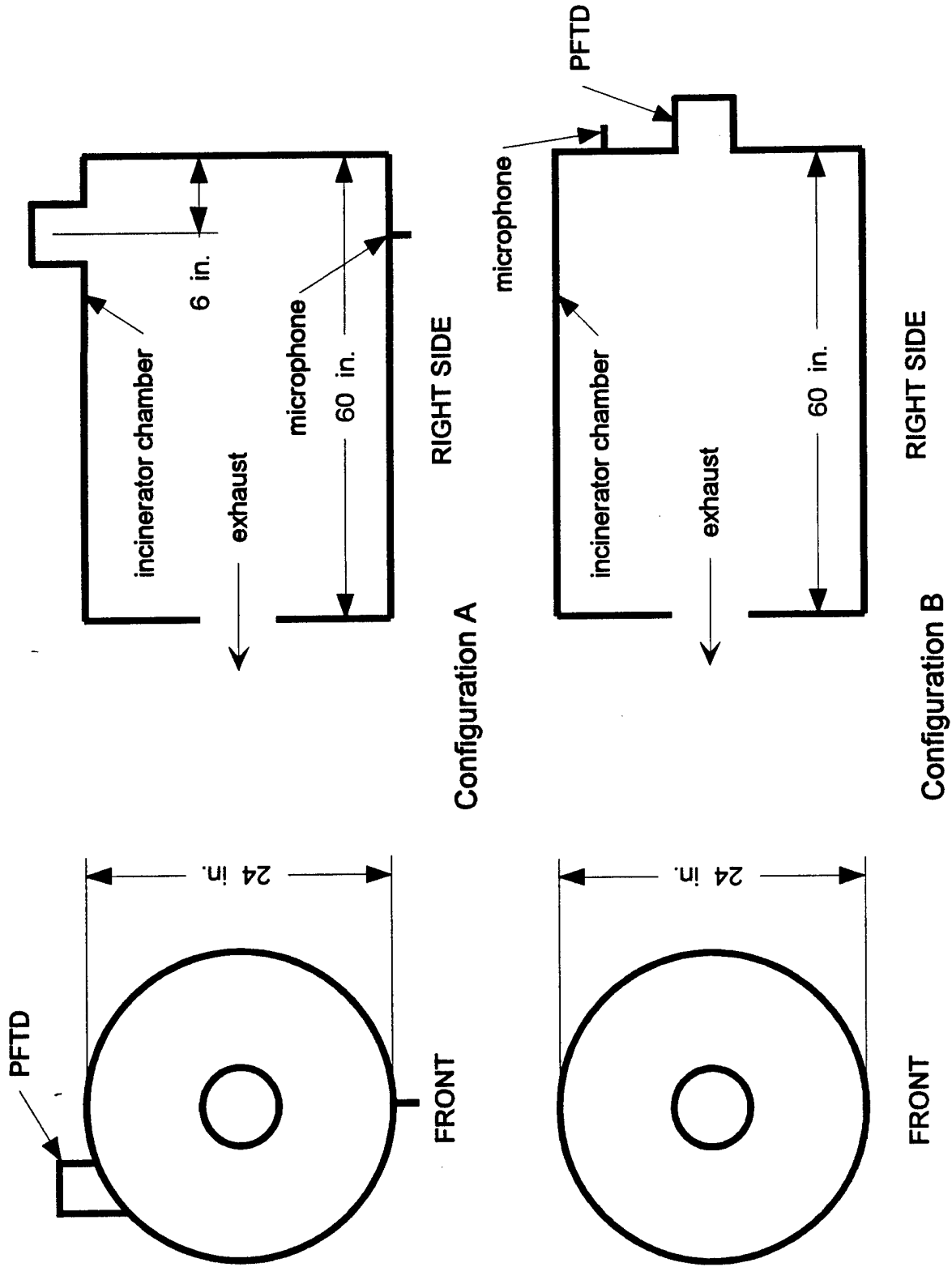

Figure 7. Configurations of pulsed flame tube driver on the incinerator chamber

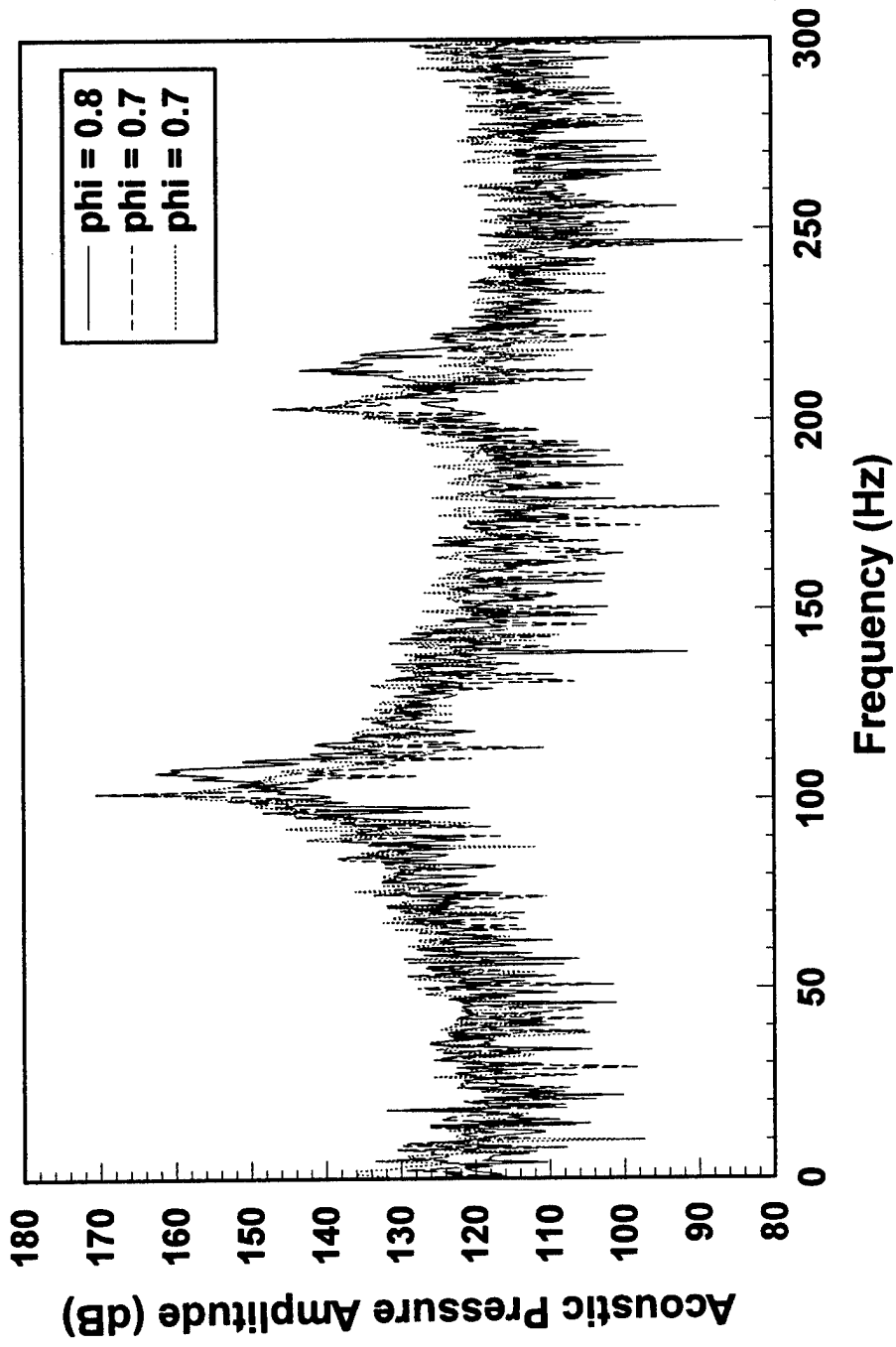

Figure 8. Self-excited oscillations driven by the PFTD in a 51" long pipe

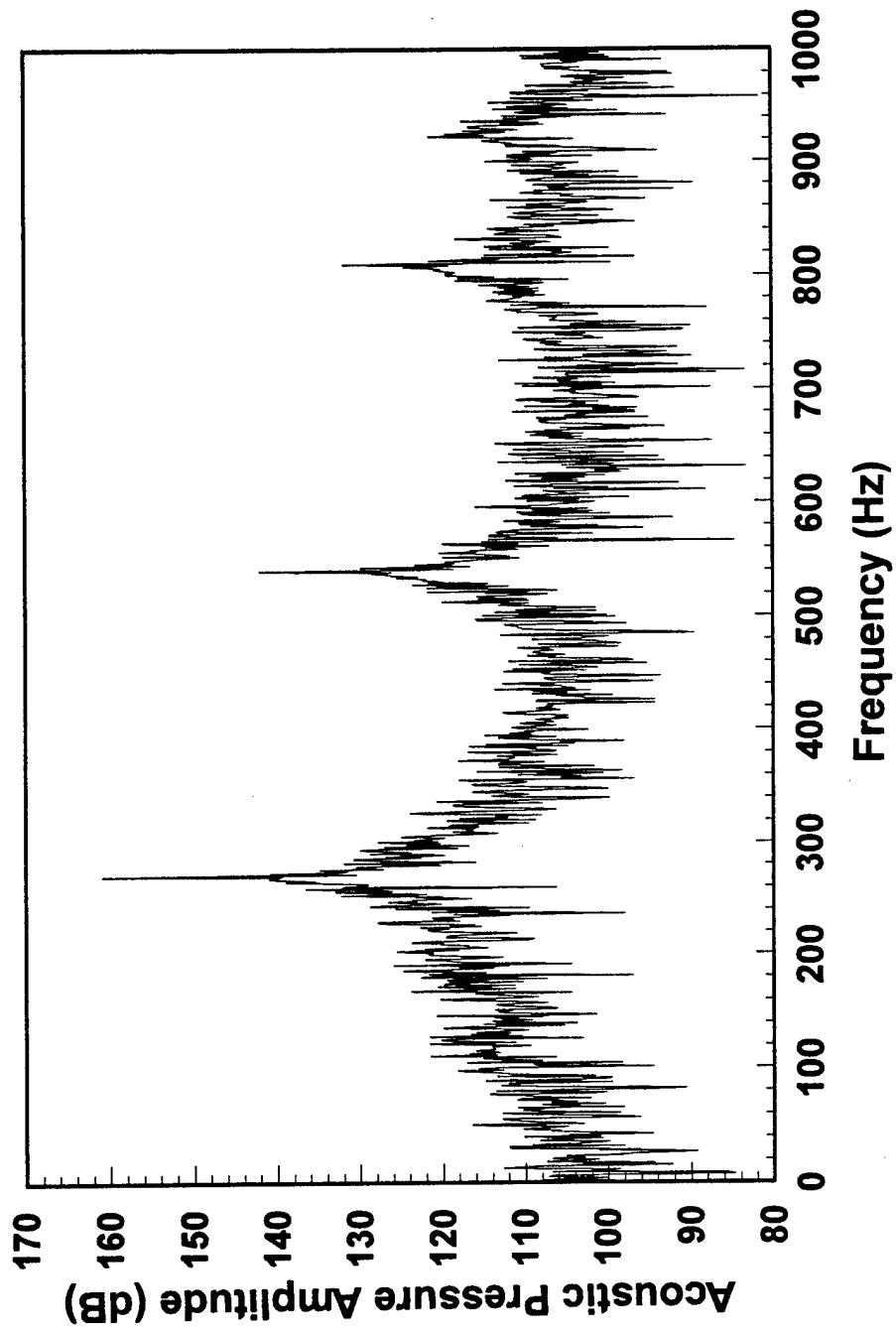

Figure 9. Acoustic pressure forced in an 18 in. long resonator pipe using the PFTD and closed loop active control.

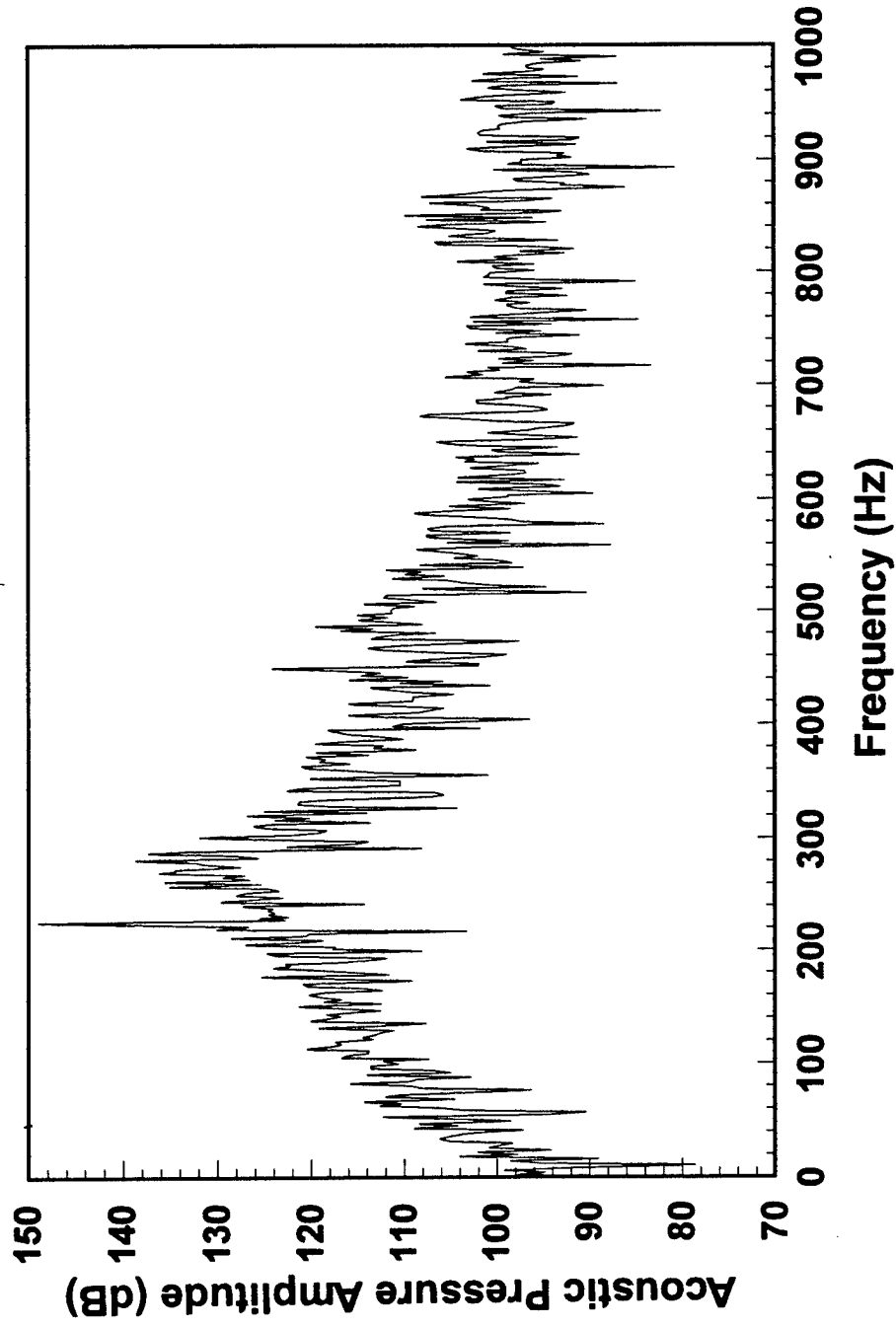

Figure 10. Example of secondary fuel injection at an off-resonant frequency in which the injection occurred at 220 Hz, while the quarter wave resonance frequency is approximately 300 Hz.

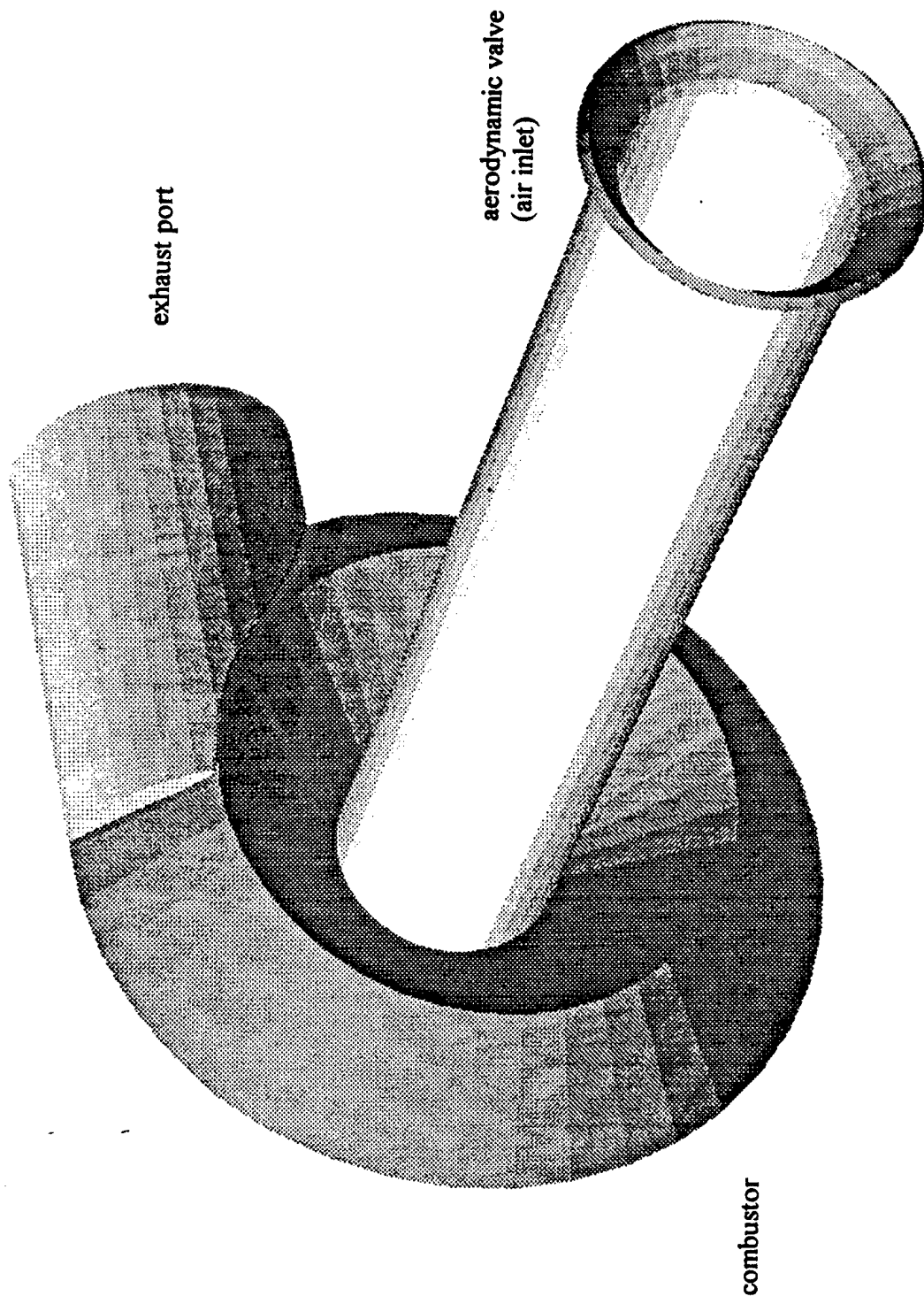

Figure 11. Schematic of the single frequency, oil burning pulse combustor

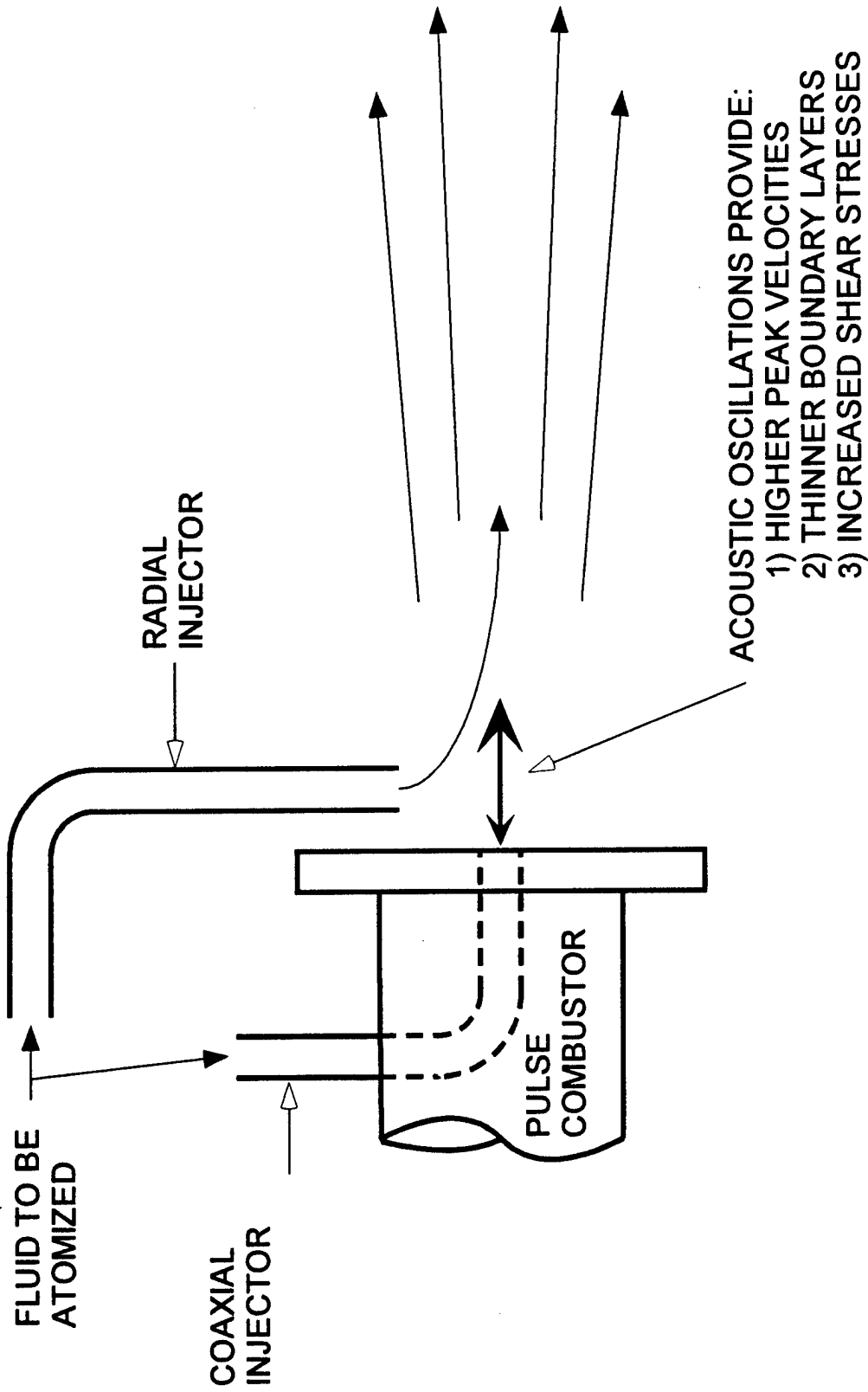
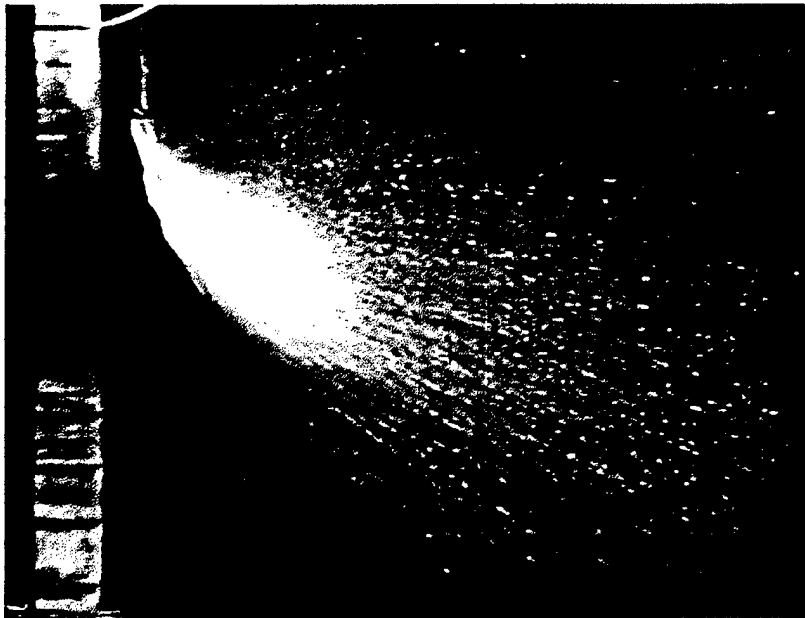
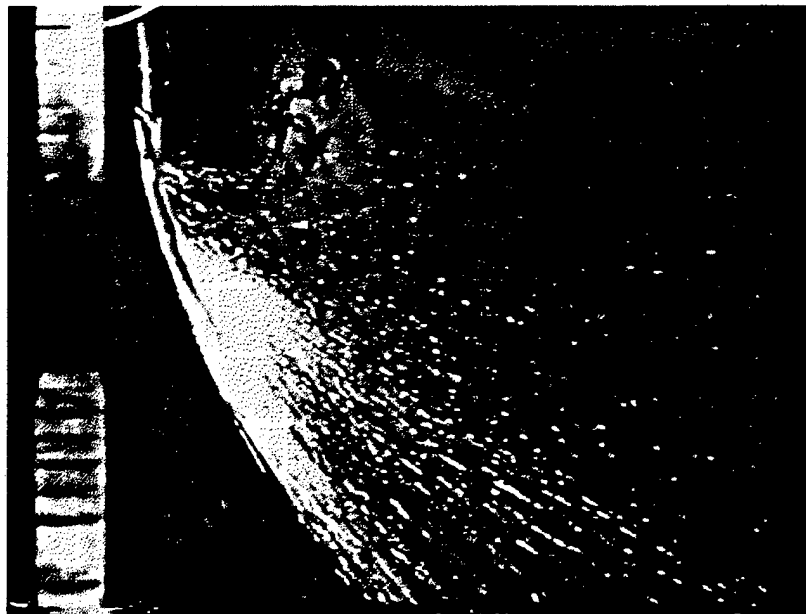

Figure 12. Atomization of liquid waste using pulse combustor exhaust



A) PULSATIONS PRESENT



B) NO PULSATIONS

Figure 13. Combustor atomization of a radially injected 0.5 GPM water stream with and without pulsations

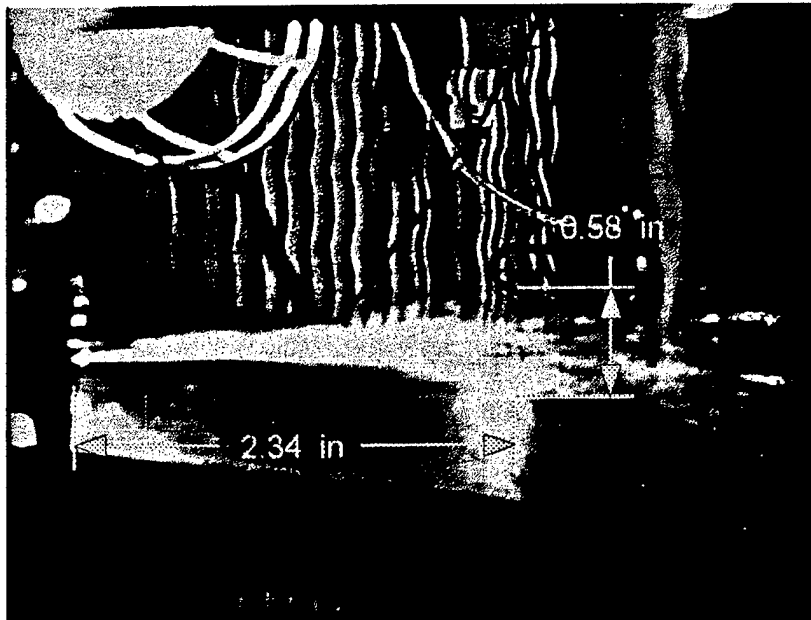

A) PULSATIONS PRESENT

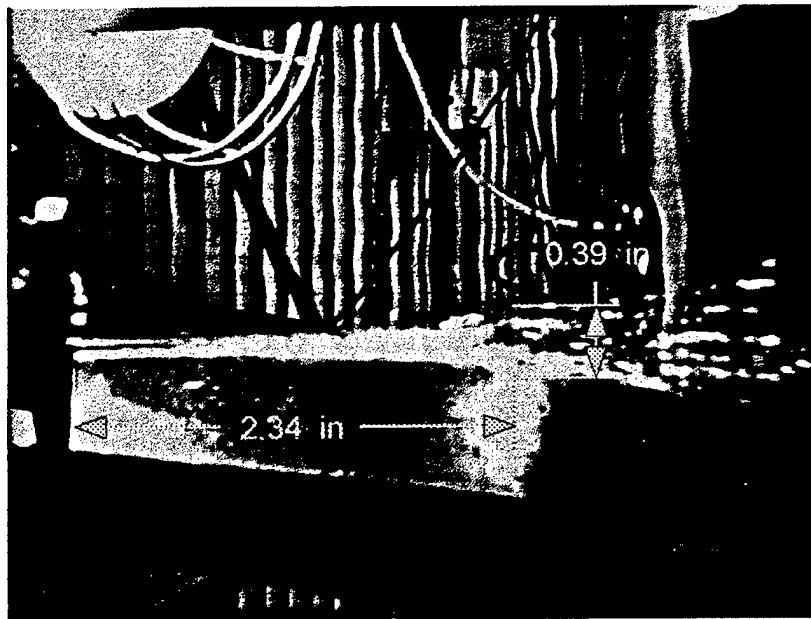

B) NO PULSATIONS

Figure 14. Combustor atomization of a coaxially injected 0.25 GPM water stream with and without pulsations.

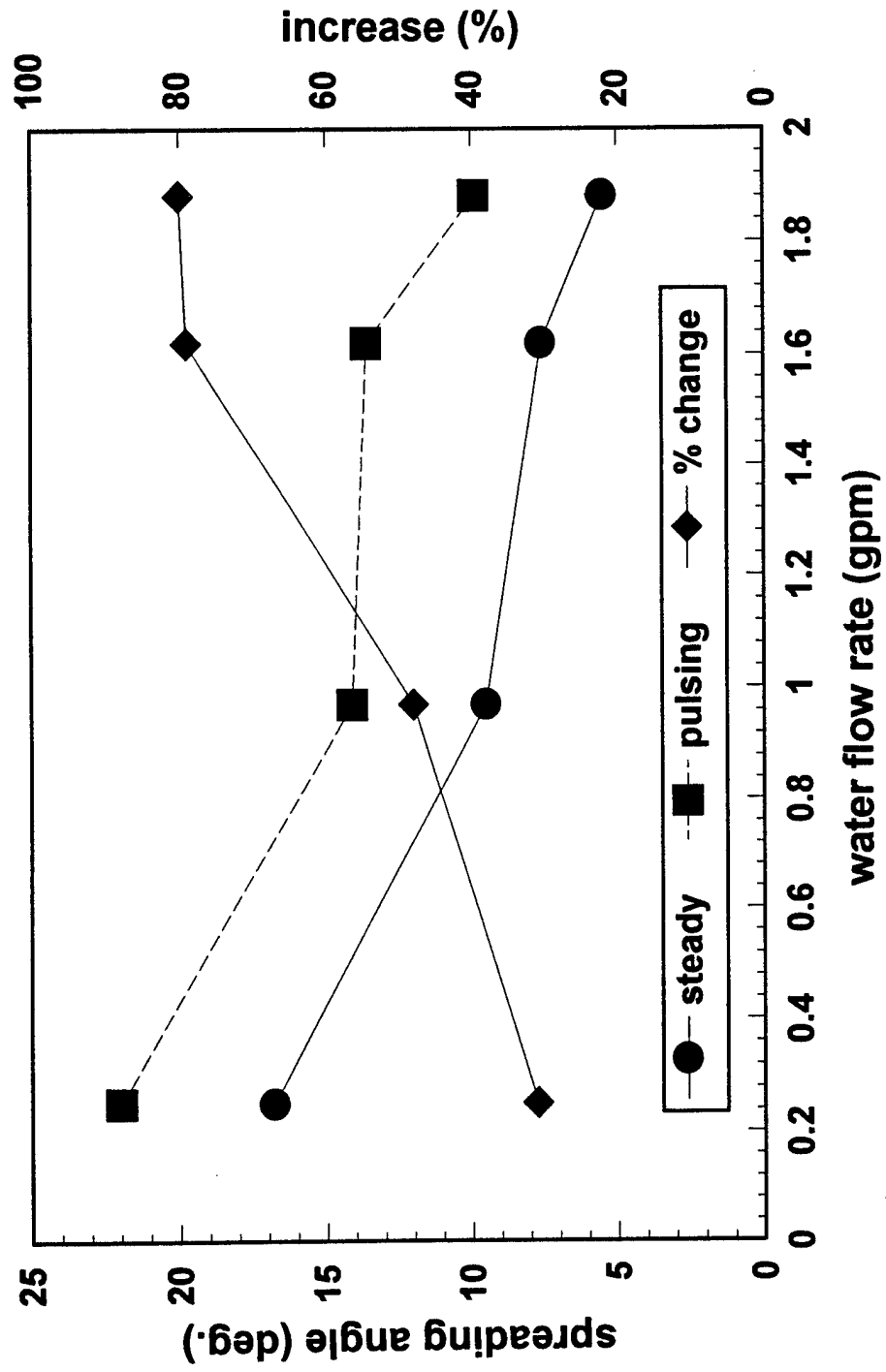

Figure 15. Effect of pulsations on coaxial atomization using a 150MBtu/hr pulse combustor