



DEPARTMENT OF THE ARMY Mr. McKeon/ls/870-2237  
ABERDEEN PROVING GROUND  
ABERDEEN PROVING GROUND, MARYLAND 21005

STEAP-MT-U

19 JUN 1973

SUBJECT: Final Letter Report of Product Improvement Test LANCE  
GSE/XM234 Warhead Cradle, TECOM Project No. 2-MI-093-LAN-003,  
Report No. APG-MT-4318

Commander  
US Army Missile Command  
ATTN: AMCPM-LCC  
Redstone Arsenal, AL 35809

1. REFERENCE:

Letter, AMSTE-FA, TECOM, 11 Jan 73, subject: Customer Test Directive: TECOM Project No. 2-MI-093-LAN-003, LANCE GSE Warhead Cradle.

2. BACKGROUND:

a. The Honeycomb Aerodynamic Structure (SKIN) of the LANCE XM234 Warhead was damaged during the engineer test/expanded service test (ET/EST) program at White Sands Missile Range (WSMR), New Mexico. This damage made it necessary to modify the warhead support cradles on the LANCE system tracked vehicles. The first modification consisted of changing the station 71.5 saddle to provide a larger bearing area (65 sq in.) and better control of hold down strap tension. The second modification consisted of moving the forward saddle from station 71.5 to station 61.54 in order to support the warhead section where structural joint rings exist. In addition to cradle modifications, shock absorbers were installed on the two rear roadwheels of the LANCE tracked vehicle to help reduce the road shock and vibration environment for the missiles.

b. All shock and vibration tests were conducted on the LANCE Loader Transporter Vehicle (Full-Tracked, M688), USA Reg. No. 12A88667, which contained the modified cradles, 65 sq in. on curb-side and the station 61.5 cradle on the roadside missile positions. The vehicle was equipped with rear wheel shock absorbers and bump stops. Two missile main assemblages XM6, Serial Nos. 5406 and 5410, and two XM234 warheads, RT1 and RT2, were used in these tests.

USATECOM Technical Information Center

19970718 005

"DTIC USERS ONLY"

DTIC QUALITY INSPECTED 1

STEAP-MT-U

SUBJECT: Final Letter Report of Product Improvement Test LANCE  
GSE/XM234 Warhead Cradle, TECOM Project No. 2-MI-093-LAN-003,  
Report No. APG-MT-4318

A follow-on 1000-mile endurance test of the Picatinny Arsenal warhead RT1 and RT2 on the 65 sq in. and station 61.5 cradle was conducted utilizing the IPT Loader Transporter Vehicle (Full-Tracked, M688), Serial No. 12A31272 and Loader Transporter Vehicle (Full-Tracked, M688), Serial No. 12A88667.

c. The Loader Transporter was operated over the various shock and vibration courses with the newly modified hardware from 29 January 1973 to 29 March 1973. The purpose of the test was to provide data needed by Picatinny Arsenal, LTV and White Sands Missile Range for evaluation of the newly designed modifications for comparison with data obtained with the original cradles during previous tests.

### 3. OBJECTIVE:

The objective of the test was to provide necessary support as follows:

a. Provide displacement transducers (bend bars) for measurement of lateral and vertical motion of missile relative to cradles.

b. Apply strain gauges on both cradles for measurement of vertical and lateral strain in the cradles.

c. Provide and install all external accelerometers on missiles and cradles.

d. Record all shock, vibration, displacement and strain data on magnetic tape.

e. Provide MICOM, Picatinny Arsenal, Sandia Corporation, WSMR and the LANCE contractor (LTV) with oscillograph records and or magnetic tape dubs of the recorded data.

f. Conduct a 1000-mile endurance test of the Picatinny Arsenal warheads RT1 and RT2 on the 65 sq in. and station 61.5 cradle.

g. Materiel Testing Directorate was not required to reduce or analyze any shock and vibration data.

Assessing the effects of these road vibration tests on structural adequacy of missiles and cradles and evaluation of modifications to the cradles is the responsibility of the contractor agencies participating in this test.

STEAP-MT-U

SUBJECT: Final Letter Report of Product Improvement Test LANCE  
GSE/XM234 Warhead Cradle, TECOM Project No. 2-MI-093-LAN-003,  
Report No. APG-MT-4318

4. SUMMARY OF RESULTS:

a. The various agencies participating in this test were responsible for reporting what effect these road tests had on the vehicle, missiles, warheads and cradles and also for evaluating cradle modifications.

b. The LANCE Loader Transporter, with missiles, was subjected to tests on the Munson, six inch washboard, two inch washboard, three inch spaced bump and radial washboard courses, six inch ramp course and on the three-mile straightaway (paved) courses. Data were recorded on all courses during two of the six instrumented test setups as requested by the Sandia Corporation. Road tests were confined to the six inch ramp course for the other four instrumented test runs.

c. A summary of the number of test runs that the LANCE Transporter and missile were subjected to on each test course during this test is shown in Table I.

Table I. Test Run Distances/Test Courses

<u>Test Course</u>	<u>Runs</u>	<u>Test Course Length</u>
Six inch ramps	34	154 ft
Six inch washboard	8	800
Two inch washboard	6	300
Three inch spaced bump	6	831
Radial washboard	5	128
Three-mile straightaway (paved)	4	3 miles

d. The 1000-mile endurance test of the Picatinny warheads was conducted as shown in Table II below:

Table II. Mileage Breakdown for Picatinny Warhead Endurance Test  
RT1 with 65 sq. in. Cradle on Right  
RT2 with Station 61.5 Cradle on Left

	<u>Vehicle, Loader Transporter, miles</u>		
	<u>12A88667</u>	<u>12A31272</u>	<u>Totals</u>
Paved	100	150	250
Gravel	100	150	250
Perryman Level Cross Country Nos 2, 3 and 4	150	100	250
Churchville Hilly Cross Country - B Course	250		<u>250</u>
			1000 miles

STEAP-MT-U

SUBJECT: Final Letter Report of Product Improvement Test LANCE  
GSE/XM234 Warhead Cradle, TECOM Project No. 2-MI-093-LAN-003,  
Report No. APG-MT-4318

5. CONCLUSIONS:

Not applicable.

6. RECOMMENDATIONS:

Not applicable.

FOR THE COMMANDER:



C. D. MONTGOMERY  
Chief, Automotive and Armor  
Division  
Materiel Testing Directorate

3 Incls

1. Details of Test
2. Test Data
3. Photographs

CF:

PM LANCE, ATTN: AMCPM-LCT, Mr. Rossi  
Redstone Ars, AL 35809 - 6 cys  
LTV Aerospace Corp - MD, ATTN:  
Mr. Brabant, Warren, MI 48090 - 2 cys  
Aerospace Structures Division  
Attn: Mr. Harold J. Black, VP of  
Engr & Design, P.O. Box 210  
Nashville, TN 37202 - 2 cys  
Sandia Laboratories (AEC) ATTN: Mr. J.  
Jones, Code 8164, Livermore, CA 94550 - 2 cys  
Cdr, USAMC, ATTN: AMCRD-WN, ATTN: Mr. Bacot,  
5001 Eisenhower Ave, Alex. VA 22304 - 1 cy  
Cdr, USATRADOC (PROV) (DCS-CD) ATCD-MR-I - COL Rider  
Ft Belvoir, VA 22060 - 1 cy  
Cdr, Picatinny Ars, ATTN: SMUPA-ND-D  
B-200, Dover, NJ 07801 - 2 cys  
Cdr, USATACOM, ATTN: AMSTA-RET.5,  
Mr. Grover, Mr. Terry, Warren, MI 48090, 2 cys  
Cdr, WSMR, ATTN: STEWS-TE-LD,  
WSMR, NM - 2 cys  
Pres, USAFABD, ATTN: STEBA-TD,  
Ft Sill, OK 73503 - 1 cy  
Cdr, USATECOM, ATTN: AMSTE-FA, APG, Md. - 1 cy  
AMSTE-NB - 1 cy  
AMSTE-SG-H - 1 cy

## DETAILS OF TEST

### Road Shock and Vibration Tests

#### Objective

Record shock, vibration, displacement and strain data on the LANCE missiles, warheads and modified cradles during transport tests on the Loader Transporter Vehicle over Munson, six inch ramps and three-mile straightaway (paved) test courses.

#### Method

The XM234 warheads were instrumented internally to measure strain in the skin and also with crystal type accelerometers to measure the shocks and vibrations at the station 61.5 support ring. This instrumentation was installed by Picatinny Arsenal.

Lateral and vertical movement of warheads relative to their support saddles, front and rear, were measured with bend bar displacement transducers made by Material Testing Directorate. These transducers were made of steel bars that were strain gauged and calibrated. They were system calibrated in increments of  $\pm .05$  in. and were installed on the cradles as shown in the photographs of Incl 3, pgs 2 thru 4.

The 65 sq. in. and the station 61.5 cradles were strain gauged with bonded foil type, 350 ohm gauges to measure vertical and lateral strain in the longitudinal beams of the cradles. Gauges were located on the tops, bottoms and sides of the beams, six inches forward and six inches aft of the cradle pivot axis. Photographs of the gauges installed on the 61.5 cradle are included in Incl 3, pg 1.

Statham Model A514TC, strain gauge type, Endevco Model 2217E, Piezo-electric type and Endevco Model 2262C, Piezo Resistive (PR) type accelerometers were used to record shock and vibration data on the missile and warheads at stations 3 (nose), 32, 85, 101, 115, 162 and 220. Accelerometers were also mounted on the cradle beams above the pivot axis. Photographs of these accelerometer locations are included in Incl 3, pgs 5 thru 9. Type, ranges, frequency response and location of the various transducers used for each instrumentation setup are included on data sheets in Incl 2, pgs 5 thru 10.

All shock, vibration, strain and displacement data were recorded on magnetic tape with the umbilical cable (data van) recording system. The data van was operated on roads alongside each test course and it also served to pace the test vehicle. The van was set up to record 36 channels of data simultaneously on three tape recorders. In addition

Inclosure 1

to data, voice annotation and IRIG time code B reference information were recorded on each tape. A block diagram of recording instrumentation is included in Incl 2, pg 1.

### Results

Six instrumented test runs (36 data channels each run) were required to record data at all the transducer locations and warhead-cradle configurations requested by the various agencies. Data sheets identifying warhead-cradle configuration and transducer locations for each of the six instrument group tests are included in Incl 2, pgs 5 thru 10. Included on these data sheets are the vehicle speeds at which data were recorded on each course.

Oscillograph transcriptions and/or tape dubs of the data were supplied during or after the tests to Sandia Corporation, Ling Temco Vaught, White Sands Missile Range and Picatinny Arsenal as required by each of these agencies. The original data tapes will be retained at Aberdeen Proving Ground for such future use as may be required.

## APPENDIX TO TEST DATA AND PHOTOGRAPHS

### Inclosure 2 - Test Data

- Page 1                      Block Diagrams of Magnetic Tape Recording and  
                                 Playback Instrumentation
- Page 2 thru 4              Diagrams and Descriptions of Test Courses
- Page 5 thru 10            Data Sheets of Transducer Locations, Warhead-Cradle  
                                 Configuration and Test Courses

### Inclosure 3 - Photographs

- Page 1                      Cradle Strain Gauge Locations
- Page 2 thru 4              General Views of Cradles and Bend Bar Installations
- Page 5 thru 9              Accelerometer Locations

BLOCK DIAGRAM OF RECORDING INSTRUMENTATION

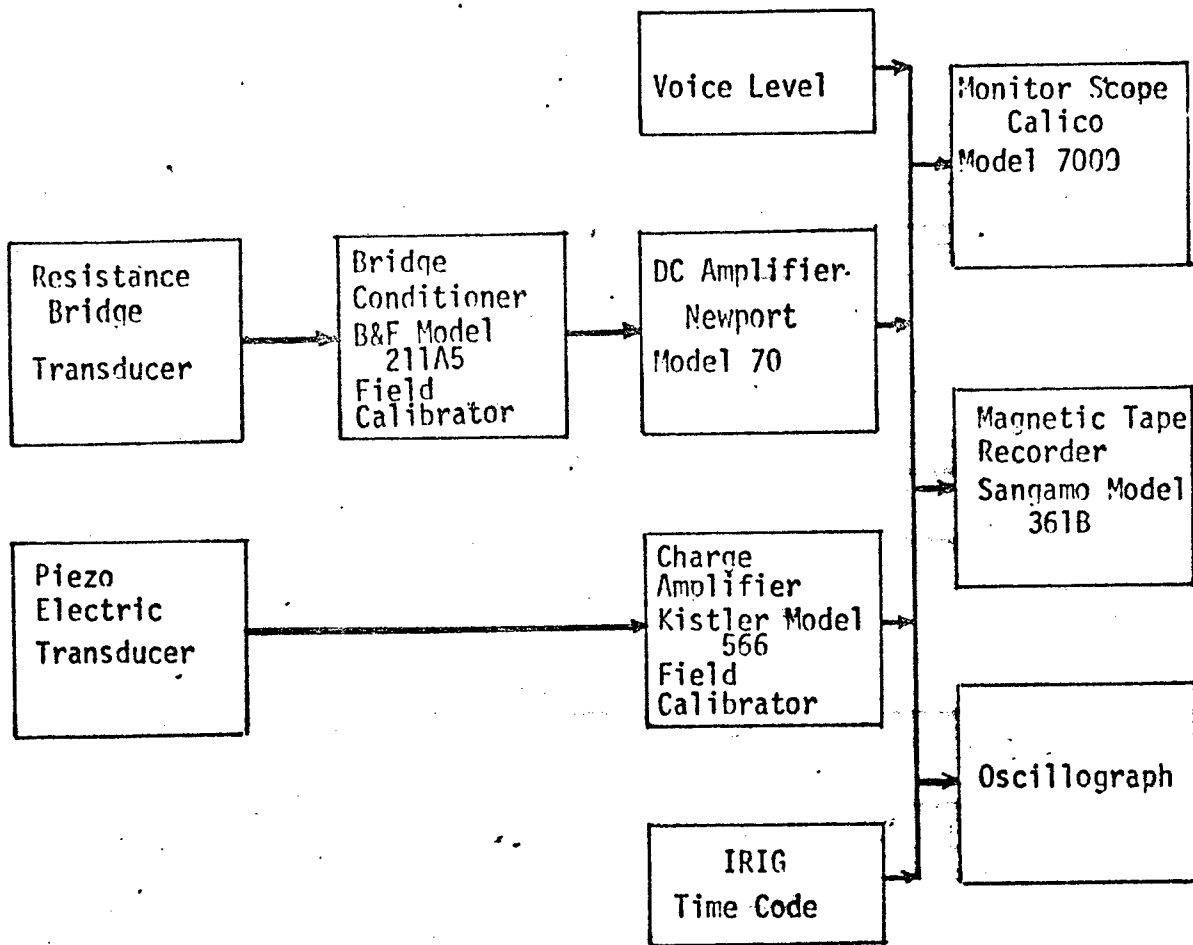

BLOCK DIAGRAM OF INSTRUMENTATION USED TO TRANSFER DATA FROM MAGNETIC TAPE TO OSCILLOGRAPH

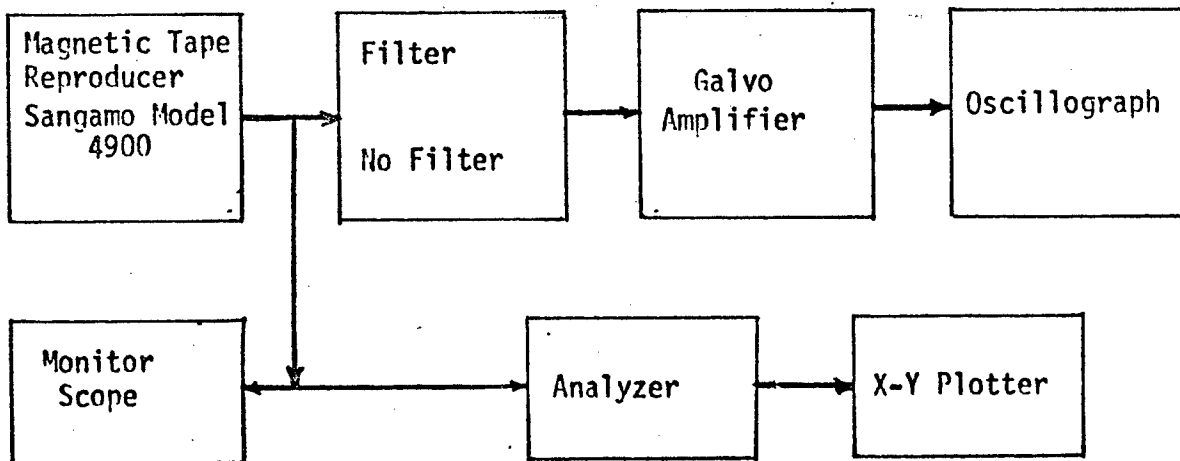

### SIX-INCH WASHBOARD COURSE

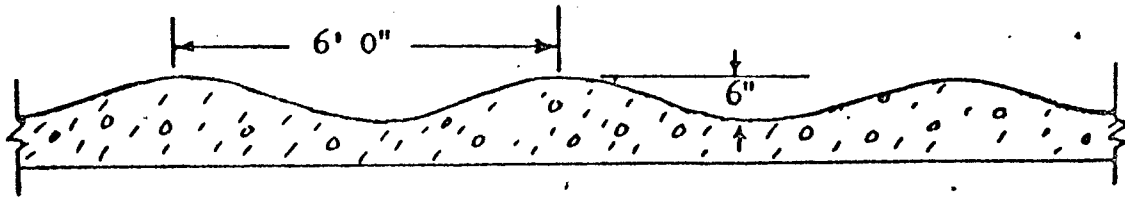

The profile approaches a sine wave with a double amplitude of six inches and a complete cycle occurring every six feet for a distance of 800 feet. The course surface is concrete.

### TWO-INCH WASHBOARD COURSE

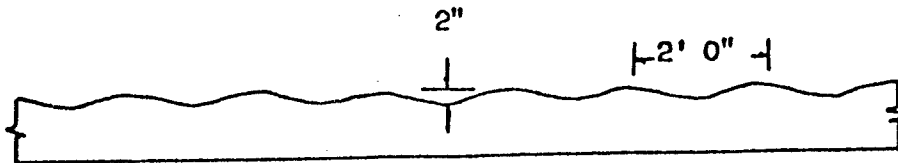

The profile approaches a sine wave with a double amplitude of two inches and a complete cycle occurring every two feet to a distance of approximately 300 feet. The course surface is concrete.

### PERRYMAN STRAIGHTAWAY

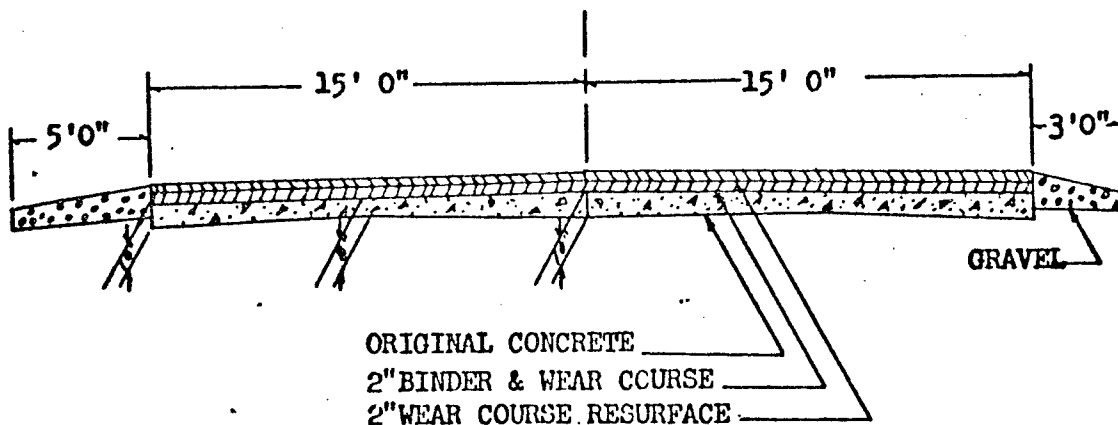

The paved straightaway is essentially a level road, three miles in length, with banked turn-around loops at each end. This course is used where high speed as well as tests requiring long periods of uninterrupted operation are desired.

### RADIAL WASHBOARD COURSE

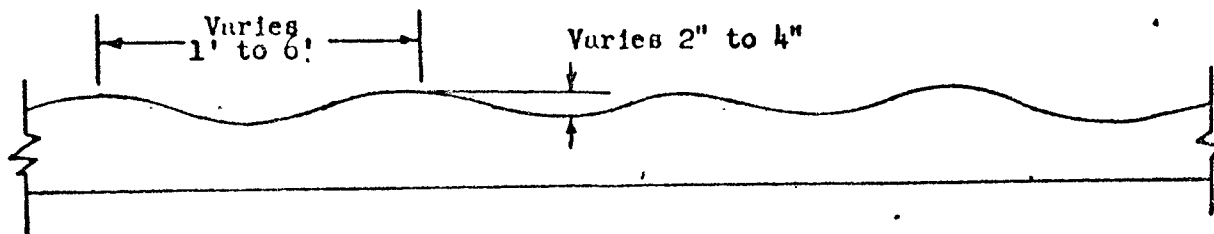

Two 90 degrees radial turns make up the Radial Washboard Course along with asymmetrical bumps which vary from two to four inches in height and from one to six feet from crest to crest. The course is 128 feet long and 20 feet wide.

### SPACED BUMP COURSE

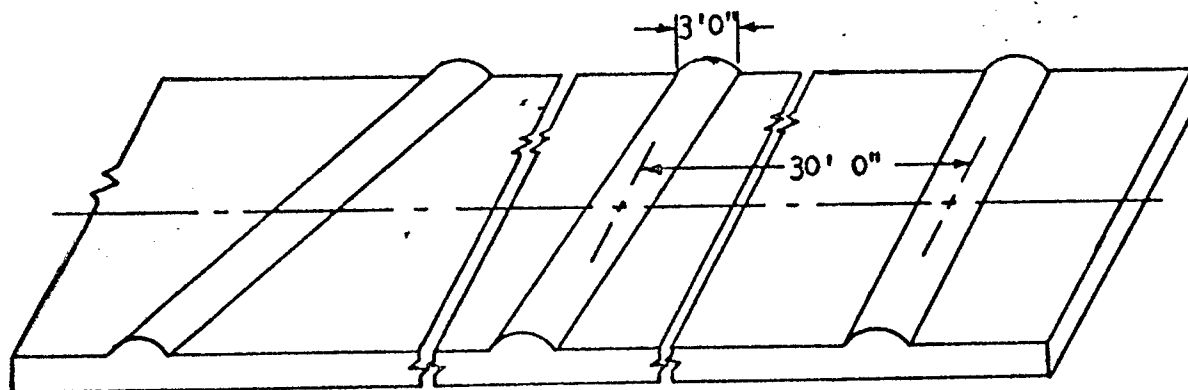

ISOMETRIC VIEW

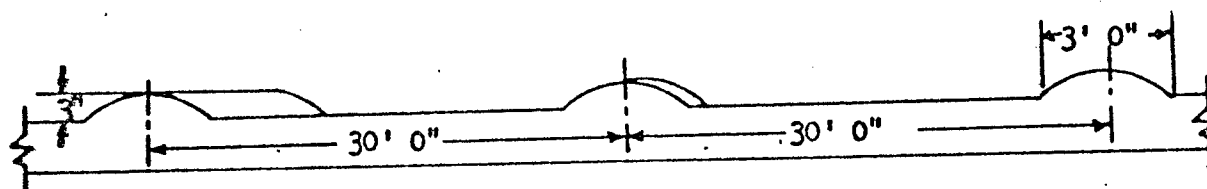

LONGITUDINAL SECTION

This course consists of a series of rounded bumps three inches high by three feet wide spaced at intervals of 30 feet along the centerline of the course. The bumps make the following angles with respect to the centerline of the course: 90°, 90°, 67°, 52°, 90°, 90°, 113°, 128°, 90°, 90°, this sequence continues for a total of twenty six bumps or three cycles for a total of 831 feet.

DIAGRAM OF SPACING FOR RAMP COURSE  
 (Ramps Placed on Bituminous Concrete Surface)

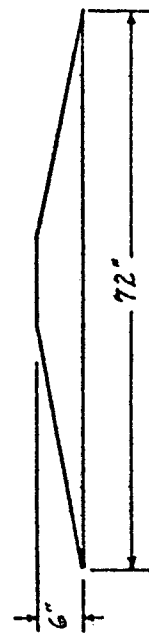
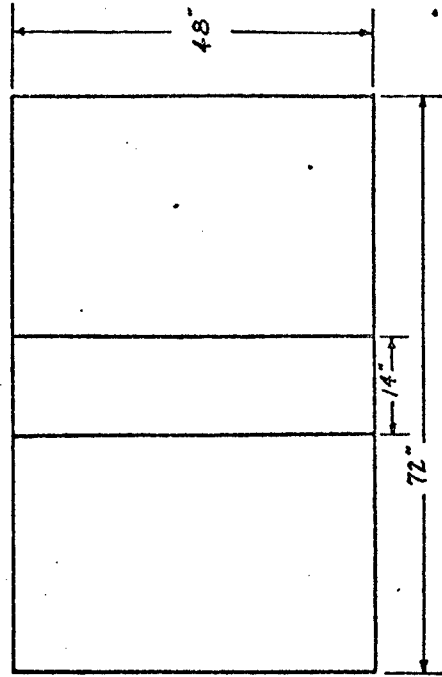
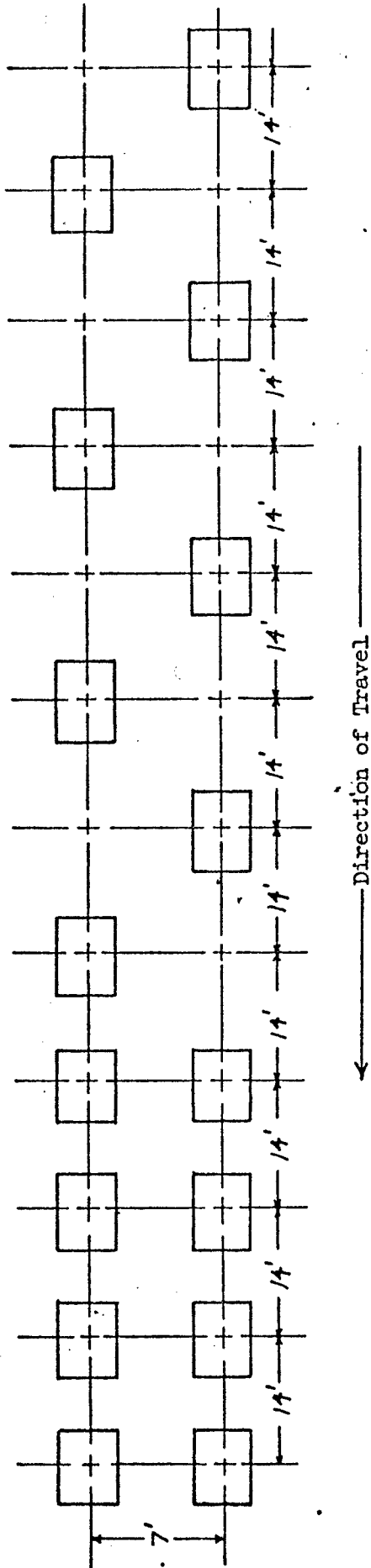

Ramp Dimensions

LANCE MISSILE SYSTEM CRADLE TEST ON THE LT VEHICLE  
Phase 1, Picatinny Arsenal Warheads  
Instrument Group No. 1

RT1 WH on 65 sq in. Cradle Curbside(CS) - RT2 WH on Sta. 61.5 Cradle Roadside(RS)

<u>Accelerometer Locations</u>	<u>Plane</u>	<u>Type of Accel.</u>	<u>Freq Range</u>
RT Ms1 Sta. 220	V,T,L	PR End. 2262C	750 Hz
RT1 Ms1 Sta. 115	V,T	PR End. 2262C	750 Hz
RT2 Ms1 Sta. 220	V,T,L	PR End. 2262C	750 Hz
RT2 Ms1 Sta. 115	V,T	PR End. 2262C	750 Hz
RT1 WH Sta. 61 (internal)	V,T,L	Crys. End 2221D	2-7000 Hz
RT2 WH Sta. 61 (internal)	V,T,L	Crys. End 2221D	2-7000 Hz
RT1 WH Cradle CS Beam above pivot	V,T,L	Crys. End 2217E	4-6000 Hz
RT2 WH Cradle RS Beam above pivot	V,T,L	Crys. End 2217E	4-6000 Hz

Picatinny Arsenal Warhead Strain Gauge Locations

RT1 WH Sta. 71.5 - 60° Left, Circular  
 99 - 90° Right, 21.5 Radius Circular  
 99 - 90° Right, 20.5 Radius Circular  
 RT2 WH Sta. 61 - 60° Right, Circular  
 99 - 90° Right, 21.5 Radius Circular  
 99 - 90° Right, 20.5 Radius Circular

Bend Bars - Relative Motion Between Warheads and Saddles

RT1 WH Cradle Aft Saddle CS - Transverse Motion  
 RT1 WH Cradle Fwd Saddle RS - Transverse Motion  
 RT2 WH Cradle Aft Saddle RS - Transverse Motion  
 RT2 WH Cradle Fwd Saddle CS - Transverse Motion

Cradle Strain Gauges on Longitudinal Beams

RT1 WH Cradle, CS Beam, Aft of Pivot - Vertical Loading  
 RT1 WH Cradle, CS Beam, Fwd of Pivot - Vertical Loading  
 RT2 WH Cradle, RS Beam, Aft of Pivot - Vertical Loading  
 RT2 WH Cradle, RS Beam, Fwd of Pivot - Vertical Loading

Data Records - Test Course and Vehicle Speeds

Six inch Ramps; 6, 7, 8, 8.5, 8.5 & 8.5 mph - Three inch Spaced Bump; 15 & 20 mph  
 Radial Washboard; 10 & 15 mph - Two inch Washboard; 2 to 8, 10, 12 mph  
 Paved Road, 10 to 34 in 2 mph increments - Six inch Washboard; 3.5, 8, 12, 16 mph

LANCE MISSILE SYSTEM CRADLE TEST ON THE LT VEHICLE  
Phase 1, Picatinny Arsenal Warheads  
Instrument Group No. 2

RT1 WH on 65 sq in. Cradle, Curbside(CS) - RT2 WH on Sta. 61.5 Cradle, Roadside(RS)

<u>Accelerometer Locations</u>	<u>Plane</u>	<u>Type of Accel.</u>	<u>Freq Range</u>
RT1 Ms1 Sta. 220	V,T,L	PR, End 2262C	750 Hz
RT1 Ms1 Sta. 115	V,T	PR, End 2262C	750 Hz
RT1 WH Sta. 85	V,T	PR, End 2262C	750 Hz
RT1 WH Sta. 32	V,T	PR, End 2262C	750 Hz
RT1 WH Sta. Nose	V,T	PR, End 2262C	750 Hz
RT1 Ms1 Sta. 100	V,T,L	Crys. End 2217E	4-6000 Hz
RT1 Ms1 Sta. 162	V,T	Crys. End 2217E	4-6000 Hz
RT1 WH Cradle CS Beam above pivot	V,T,L	Crys. End 2217E	4-6000 Hz
RT1 WH Sta. 61 (internal)	V,T,L	Crys. End 2221D	2-7000 Hz
RT2 WH Sta. 61 (internal)	V	Crys. End 2221D	2-7000 Hz

Picatinny Arsenal Warhead Strain Gauge Locations

RT1 WH Sta. 71 - 60° Right, Longitudinal  
 RT1 WH Sta. 71 - 60° Right, Circular  
 RT1 WH Sta. 99 - 90° Right, 20.5 Radius Circular  
 RT2 WH Sta. 61 - 60° Right, Circular  
 RT2 WH Sta. 99 - 90° Right, 20.5 Radius Circular

Bend Bars - Relative Motion Between Warheads and Saddles

RT1 WH Cradle, Aft Saddle CS - Transverse Motion  
 RT1 WH Cradle, Aft Saddle CS - Vertical Motion  
 RT1 WH Cradle, Fwd Saddle RS - Transverse Motion  
 RT1 WH Cradle Fwd Saddle RS - Vertical Motion

Cradle Strain Gauges on Longitudinal Beams

RT1 WH Cradle, CS Beam Aft of Pivot - Vertical Loading  
 RT1 WH Cradle, CS Beam Fwd of Pivot - Vertical Loading  
 RT1 WH Cradle, RS Beam Aft of Pivot - Vertical Loading  
 RT1 WH Cradle, RS Beam Fwd of Pivot - Vertical Loading

Data Records - Test Courses and Vehicle Speeds

Six inch Ramp Course - 6, 7, 8, 8.5, 8.5, 8.5 mph

LANCE MISSILE SYSTEM CRADLE TEST ON THE LT VEHICLE  
Phase 1, Picatinny Arsenal Warheads  
Instrument Group No. 3

RT1 WH on 65 sq in. Cradle, Curbside(CS) - RT2 WH on Sta. 61.5 Cradle, Roadside(RS)

<u>Accelerometer Locations</u>	<u>Plane</u>	<u>Type of Accel.</u>	<u>Freq Range</u>
RT2 Ms1 Sta. 220	V,T,L	PR, End. 2262C	750 Hz
RT2 Ms1 Sta. 115	V,T	PR, End. 2262C	750 Hz
RT2 WH Sta. 85	V,T	PR, End. 2262C	750 Hz
RT2 WH Sta. 32	V,T	PR, End. 2262C	750 Hz
RT2 WH Sta. Nose	V,T	PR, End. 2262C	750 Hz
RT2 Ms1 Sta. 100	V,T	Crys. End. 2217E	4-6000 Hz
RT2 Ms1 Sta. 162	V,T	Crys. End. 2217E	4-6000 Hz
RT2 WH Cradle RS Beam above pivot	V,T,L	Crys. End. 2217E	4-6000 Hz
RT2 WH Sta. 61 (internal)	V,T,L	Crys. End. 2221D	2-7000 Hz
RT1 WH Sta. 61 (internal)	V	Crys. End. 2221D	2-7000 Hz

Picatinny Arsenal Warhead Strain Gauge Locations

RT2 WH Sta. 60 - 60<sup>0</sup> Right, Circular  
 RT2 WH Sta. 61 - 60<sup>0</sup> Right, Circular  
 RT2 WH Sta. 99 - 90<sup>0</sup> Right, 20.5 Radius Circular  
 RT1 WH Sta. 71 - 60<sup>0</sup> Right, Circular  
 RT1 WH Sta. 99 - 90<sup>0</sup> Right, 20.5 Radius Circular

Bend Bars - Relative Motion Between Warheads and Saddles

RT2 WH Cradle, Aft Saddle, RS - Transverse Motion  
 RT2 WH Cradle, Aft Saddle, RS - Vertical Motion  
 RT2 WH Cradle, Fwd Saddle, CS - Transverse Motion  
 RT2 WH Cradle, Fwd Saddle, CS - Vertical Motion

Cradle Strain Gauges on Longitudinal Beams

RT2 WH Cradle CS Beam Aft of Pivot - Vertical Loading  
 RT2 WH Cradle CS Beam Fwd of Pivot - Vertical Loading  
 RT2 WH Cradle RS Beam Aft of Pivot - Vertical Loading  
 RT2 WH Cradle RS Beam Fwd of Pivot - Vertical Loading

Data Records - Test Course and Vehicle Speeds

Six inch Ramp Course - 6, 7, 8, 8.5, 8.5, 8.5 mph

LANCE MISSILE SYSTEM CRADLE TEST ON THE LT VEHICLE  
Phase 1, Picatinny Arsenal Warheads  
Instrument Group No. 4

RT1 WH on 65 sq in. Cradle, Curbside(CS) - RT2 WH on Sta. 61.5 Cradle, Roadside(RS)

<u>Accelerometer Locations</u>	<u>Plane</u>	<u>Type of Accel.</u>	<u>Freq Range</u>
RT1 Ms1 Sta. 220	V,T	Crys. End 2217E.	4-6000 Hz
RT2 Ms1 Sta. 220	V,T	Crys. End 2217E	4-6000 Hz
RT2 Ms1 Sta. 115	V,T	Crys. End 2217E	4-6000 Hz
RT1 WH Sta. 61 (internal)	V,T,L	Crys. End 2221D	2-7000 Hz
RT2 WH Sta. 61 (internal)	V,T,L	Crys. End 2221D	2-7000 Hz
RT1 Ms1 Sta. 115	V,T	Str Ga.Stat.A514TC	500 Hz
Vehicle Hull Rear, Curbside	V	Str Ga.Stat.A514TC	500 Hz
Vehicle Hull Rear, Roadside	V	Str Ga.Stat.A514TC	500 Hz

Picatinny Arsenal Warhead Strain Locations

RT1 WH Sta. 68.5 - 60° Right, Longitudinal  
 RT1 WH Sta. 68.5 - 60° Right, Circular  
 RT1 WH Sta. 68.5 - 30° Right, Longitudinal  
 RT1 WH Sta. 68.5 - 30° Right, Circular  
 RT1 WH Sta. 68.5 - 180° Longitudinal  
 RT1 WH Sta. 71.5 - 60° Right, Longitudinal  
 RT1 WH Sta. 71.5 - 60° Right, Circular  
 RT1 WH Sta. 74.5 - 60° Right, Longitudinal  
 RT1 WH Sta. 74.5 - 60° Right, Circular  
 RT1 WH Sta. 71.5 - 60° Left, Longitudinal  
 RT1 WH Sta. 99 - 90° Right, 21.5 Radius Circular  
 RT1 WH Sta. 99 - 90° Right, 20.5 Radius Circular  
 RT1 WH Sta. 99 - 0° , 21.5 Radius Circular  
 RT1 WH Sta. - 0° , 20.5 Radius Circular  
 RT1 WH Sta. 74.5 - 30° Right, Longitudinal  
 RT1 WH Sta. 74.5 - 30° Right, Circular  
 RT2 WH Sta. 61 - 60° Right, Circular  
 RT2 WH Sta. 99 - 90° Right, 20.5 Radius Circular

Cradle Strain Gauges on Longitudinal Beams

RT1 WH Cradle CS Beam Aft of Pivot - Vertical Loading  
 RT1 WH Cradle CS Beam Fwd of Pivot - Vertical Loading

Data Records - Test Courses and Vehicle Speeds

6" Ramps, 7,8,8.5,8.5,8.5 mph - 6" WB, 3.5, 8, 12, 16 mph  
 2" WB, 3-7, 9, 11 mph - Sp Bump, 14, 16, 18, 20 mph - Rad WB, 14, 16, 18 mph  
 Paved Road, 10 to 38 mph in 2 mph increments

LANCE MISSILE SYSTEM CRADLE TEST ON THE LT VEHICLE  
Phase 1, Picatinny Arsenal Warheads  
Instrument Group No. 5

RT1 WH on 65 sq in. Cradle, Curbside(CS) - RT2 WH on Sta. 61.5 Cradle, Roadside(RS)

<u>Accelerometer Locations</u>	<u>Plane</u>	<u>Type of Accel.</u>	<u>Freq Range</u>
RT1 Ms1 Sta. 220	V,T	Crys. End 2217E	4-6000 Hz
RT1 Ms1 Sta. 115	V,T	Crys. End 2217E	4-6000 Hz
RT2 Ms1 Sta. 220	V,T	Crys. End 2217E	4-6000 Hz
RT2 Ms1 Sta. 115	V,T	Crys. End 2217E	4-6000 Hz
RT1 WH Sta. 61 (internal)	V,T	Crys. End 2221D	2-7000 Hz
RT2 WH Sta. 61 (internal)	V,T	Crys. End 2221D	2-7000 Hz

Picatinny Arsenal Warhead Strain Gauge Locations

<u>RT1 WH</u>	<u>RT1 WH</u>
Sta. 68.5 - 60 <sup>0</sup> L, Long	Sta. 74.5 - 0 <sup>0</sup> Long
Sta. 68.5 - 60 <sup>0</sup> L, Circ	Sta. 74.5 - 0 <sup>0</sup> Circ
Sta. 68.5 - 30 <sup>0</sup> L, Long	Sta. 99 - 95 <sup>0</sup> L, 21.5 Rad Circ
Sta. 68.5 - 30 <sup>0</sup> L, Circ	Sta. 99 - 95 <sup>0</sup> L, 20.5 Rad Circ
Sta. 68.5 - 0 <sup>0</sup> , Long	Sta. 99 - 0 <sup>0</sup> , 21.5 Rad Circ
Sta. 68.5 - 0 <sup>0</sup> , Circ	Sta. 99 - 0 <sup>0</sup> , 20.5 Rad Circ
Sta. 71.5 - 60 <sup>0</sup> L, Long	Sta. 71.5 - 60 <sup>0</sup> R, Circ
Sta. 71.5 - 60 <sup>0</sup> L, Circ	Sta. 99 - 90 <sup>0</sup> R, 20.5 Rad Circ
Sta. 74.5 - 60 <sup>0</sup> L, Long	<u>RT 2 WH</u>
Sta. 74.5 - 60 <sup>0</sup> L, Circ	Sta. 61 - 60 <sup>0</sup> R, Circ
Sta. 74.5 - 30 <sup>0</sup> L, Long	Sta. 99 - 90 <sup>0</sup> R, Circ
Sta. 74.5 - 30 <sup>0</sup> L, Circ	

Cradle Strain Gauges on Longitudinal Beams

RT1 WH Cradle RS Beam Aft of Pivot - Vertical Loading  
RT1 WH Cradle RS Beam Fwd of Pivot - Vertical Loading

Data Records - Test Courses and Vehicle Speeds

Six inch Ramps - 6, 7, 8, 8.5 and 8.5 mph

LANCE MISSILE SYSTEM CRADLE TEST ON THE LT VEHICLE  
Phase 1, Picatinny Arsenal Warheads  
Instrument Group No. 6

RT1 WH on 65 sq in. Cradle, Curbside(CS) - RT2 WH on Sta. 61.5 Cradle, Roadside(RS)

<u>Accelerometer Locations</u>	<u>Plane</u>	<u>Type of Accel.</u>	<u>Freq Response</u>
RT1 Ms1 Sta. 220	V,T	Crys. End 2217E	4-6000 Hz
RT1 Ms1 Sta. 115	V,T	Crys. End 2217E	4-6000 Hz
RT1 WH Sta. 61 (external)	V,T	Crys. End 2217E	4-6000 Hz
RT2 Ms1 Sta. 220	V,T	Crys. End 2217E	4-6000 Hz
RT2 Ms1 Sta. 115	V,T	Crys. End 2217E	4-6000 Hz
RT2 WH Sta. 61 (internal)	V,T	Crys. End 2221D	2-7000 Hz

Picatinny Arsenal Warhead Strain Gauge Locations

<u>RT2 Warhead</u>	<u>RT2 Warhead</u>
Sta. 57 - 0° Long	Sta. 61 - 0° Circ
Sta. 57 - 180° Long	Sta. 61 - 30°L, Circ
Sta. 60 - 60°R, Circ	Sta. 61 - 60°L, Circ
Sta. 60 - 30°R, Circ	Sta. 65 - 0° , Long
Sta. 60 - 0° Circ	Sta. 65 - 180° Long
Sta. 60 - 30°L, Circ	Sta. 99 - 90°R, 21.5 Rad Circ
Sta. 60 - 60°L, Circ	Sta. 99 - 90°R, 20.5 Rad Circ
Sta. 61 - 60°R, Circ	Sta. 99 - 0° , 21.5 Rad Circ
Sta. 61 - 30°R, Circ	Sta. 99 - 0° , 20.5 Rad Circ

Bend Bars - Relative Motion Between Warhead and Saddles

RT2 WH Cradle Fwd Saddle CS - Transverse Motion  
RT2 WH Cradle Fwd Saddle CS - Vertical Motion

Cradle Strain Gauges on Longitudinal Beams

RT2 WH Cradle, RS Beam Aft of Pivot - Transverse Loading  
RT2 WH Cradle, RS Beam Fwd of Pivot - Transverse Loading  
RT2 WH Cradle, RS Beam Aft of Pivot - Vertical Loading  
RT2 WH Cradle, RS Beam Fwd of Pivot - Vertical Loading

Data Records - Test Courses and Vehicle Speeds

Six inch Ramp Course - 6, 7, 8, 8.5, 8.5, 8.5 mph

LANCE Missile System Cradle Test on the LT Vehicle  
Phase 1 - Picatinny Arsenal Warheads

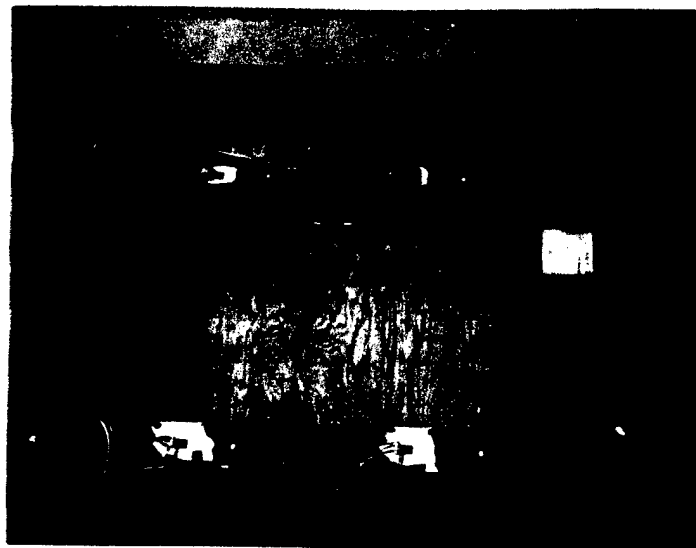
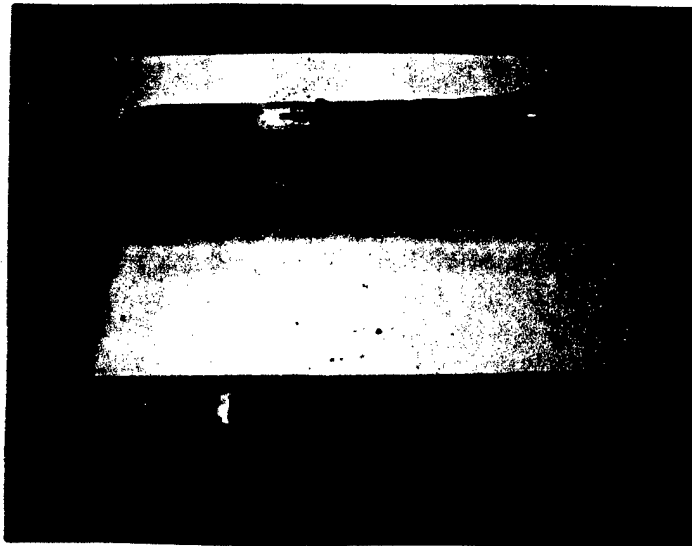

General View of Strain Gauge Locations on the Station 61.5 LANCE  
Warhead Cradle

LANCE MISSILE SYSTEM CRADLE TEST ON THE LT VEHICLE  
Phase 1 - Picatinny Arsenal Warheads

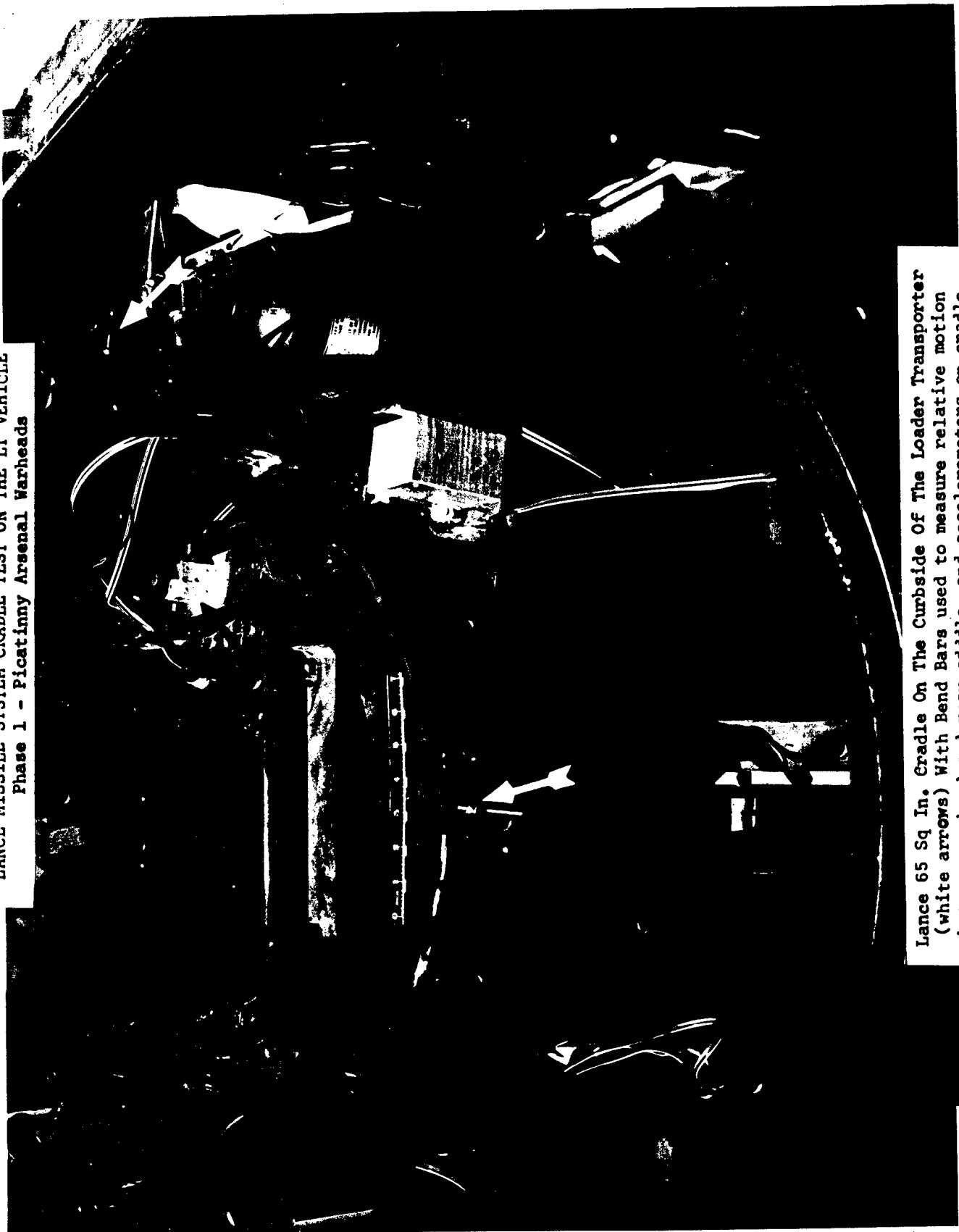

Lance 65 Sq In. Cradle On The Curbside Of The Loader Transporter  
(white arrows) With Bend Bars used to measure relative motion  
between warhead and rear saddle, and accelerometers on cradle  
beam above pivot (black arrows)

LANCE MISSILE SYSTEM CRADLE TEST ON THE LT VEHICLE  
Phase 1 - Picatinny Arsenal Warheads



Lance 65 Sq In. Cradle On The Curbside Of The Loader Transporter With  
(1) Bend Bars used to measure relative motion between warhead and  
rear saddle, and accelerometers on cradle above pivot.

BEND BAR POSITIONED TO MEASURE TRANSVERSE MOTION  
OF WARHEAD RELATIVE TO SADDLE



LANCE MISSILE SYSTEM CRADLE TEST ON THE LT VEHICLE  
Phase 1 - Picatinny Arsenal Warheads

Incl 3, pg 4

1

**LANCE MISSILE SYSTEM, XM234 WARHEAD CRADLE TEST**  
**Phase II, Picatinny Arsenal and Sandia Warheads**

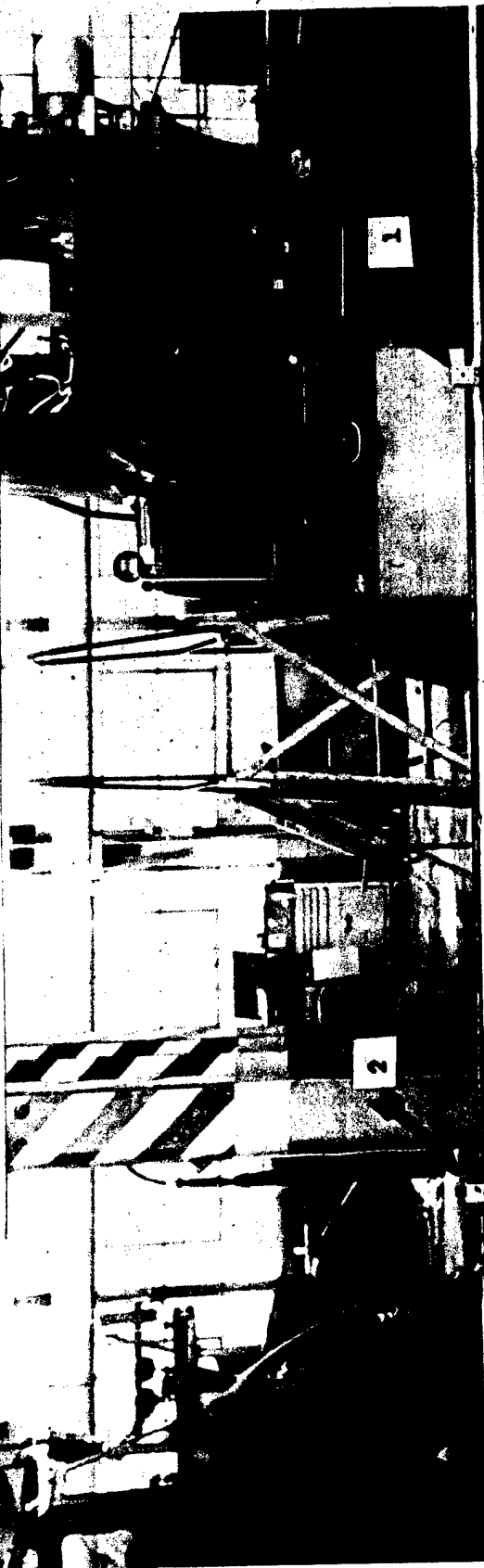

FW/TWHS

FW/TWHS

FW/TWHS

GUIDED MISSILE MAIN ASSEMBLY TNG. ANG  
 LOT NO. SERIAL AND DATE LOADED  
 GROSS WT. DATE LOADED  
 STORAGE TEMP. LIMITS -65 F TO +155 F.  
 FIRING TEMP. LIMITS -40 F TO +140 F.

U

LIFT  
HERE ↓

LIFT  
HERE ↓

**Accelerometer Mounting Locations On Missile at (1) Station 162 and (2) Station 220**

LANCE MISSILE SYSTEM CRADLE TEST ON THE LT VEHICLE  
Phase 1 - Picatinny Arsenal Warheads



LOCATION OF ACCELEROMETERS ON XM234 WARHEAD AT STATION 1  
(white arrow) (NOSE) AND AT STATION 32 (black arrow)

Incl 3, pg 6

LANCE MISSILE SYSTEM CRADLE TEST ON THE LT VEHICLE  
Phase 1 - Picatinny Arsenal Warheads



ACCELEROMETER LOCATIONS: (1) STATION 85,  
(2) STATION 101, AND (3) STATION 115

Incl 3, pg 7

LANCE MISSILE SYSTEM CRADLE TEST ON THE LT VEHICLE  
Phase 1 - Picatinny Arsenal Harheads

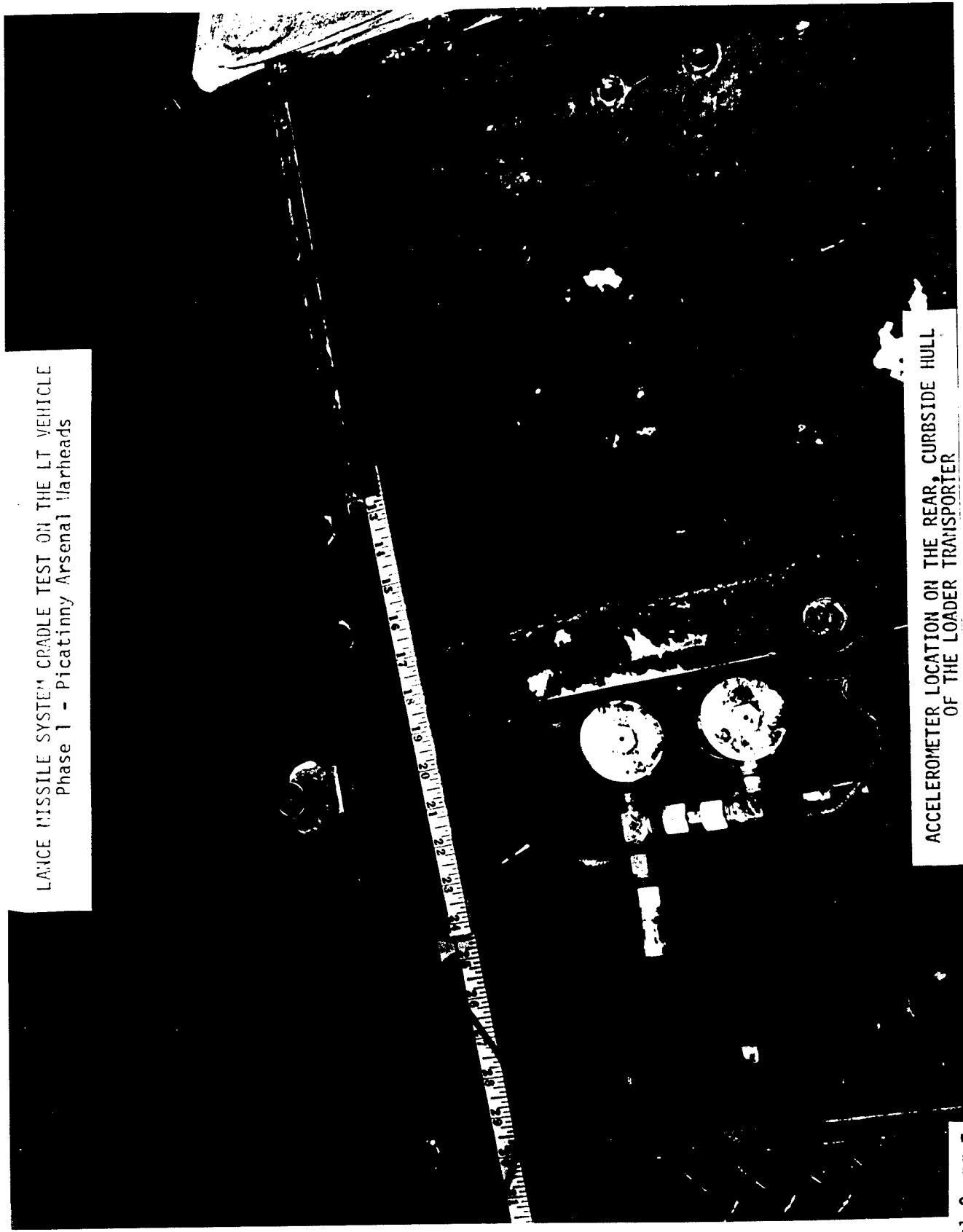

ACCELEROMETER LOCATION ON THE REAR, CURBSIDE HULL  
OF THE LOADER TRANSPORTER

LANCE MISSILE SYSTEM CRADLE TEST ON THE LT VEHICLE  
Phase 1 - Picatinny Arsenal Warheads

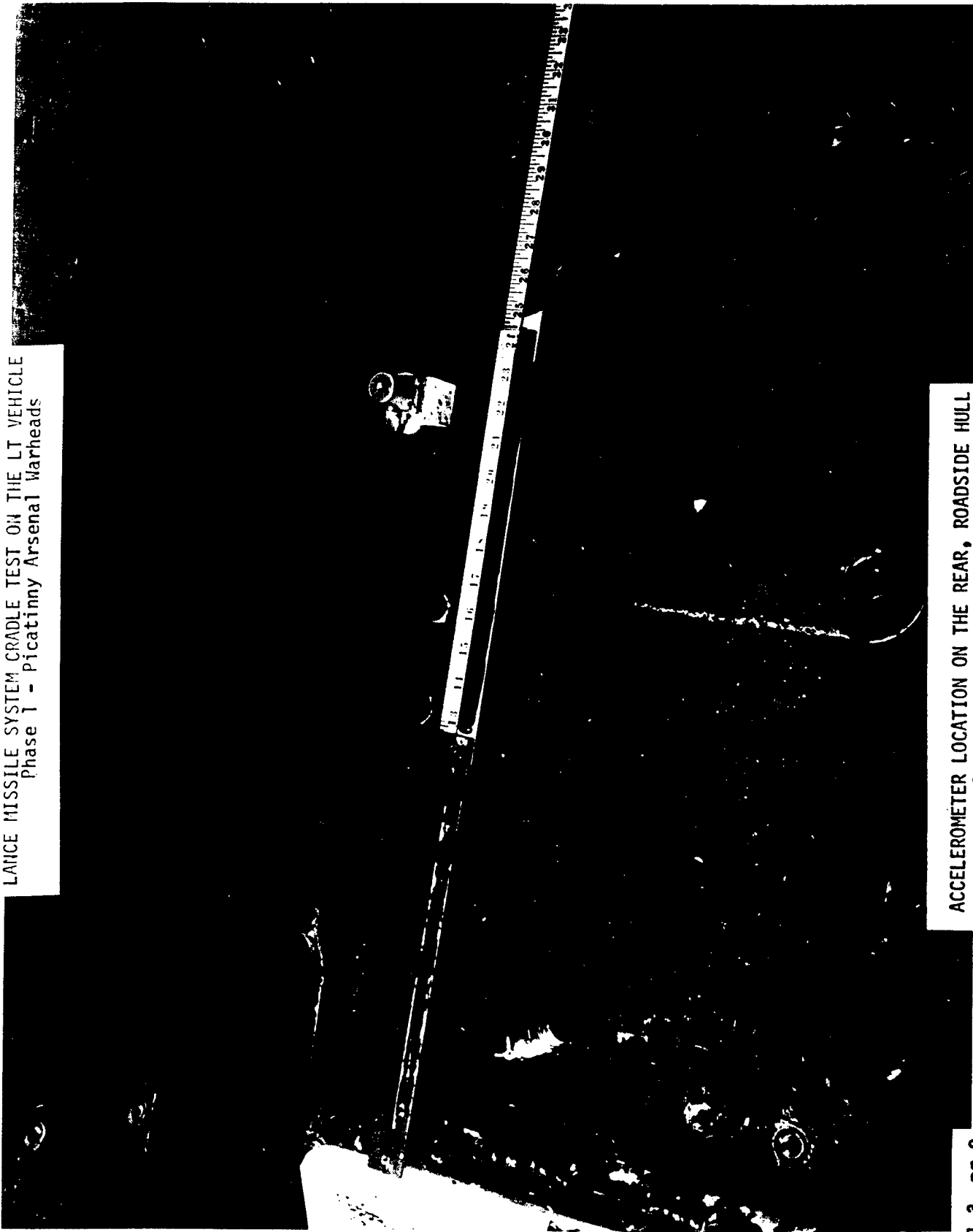

ACCELEROMETER LOCATION ON THE REAR, ROADSIDE HULL  
OF THE LOADER TRANSPORTER

Incl 3, pg 9