

NAVAL POSTGRADUATE SCHOOL
Monterey, California



THESIS

**COMPARISON OF THE STEP FREQUENCY
RADAR WITH THE CONVENTIONAL
CONSTANT FREQUENCY RADARS**

by

Dimitrios N. Geladakis

December, 1996

Thesis Advisor:

Gurnam S. Gill

Approved for public release; distribution is unlimited.

19970801 046

DISCONTINUED

REPORT DOCUMENTATION PAGE

Form Approved OMB No. 0704-0188

Public reporting burden for this collection of information is estimated to average 1 hour per response, including the time for reviewing instruction, searching existing data sources, gathering and maintaining the data needed, and completing and reviewing the collection of information. Send comments regarding this burden estimate or any other aspect of this collection of information, including suggestions for reducing this burden, to Washington Headquarters Services, Directorate for Information Operations and Reports, 1215 Jefferson Davis Highway, Suite 1204, Arlington, VA 22202-4302, and to the Office of Management and Budget, Paperwork Reduction Project (0704-0188) Washington DC 20503.

1. AGENCY USE ONLY (Leave blank)	2. REPORT DATE December 1996	3. REPORT TYPE AND DATES COVERED Master's Thesis	
4. TITLE AND SUBTITLE COMPARISON OF THE STEP FREQUENCY RADAR WITH THE CONVENTIONAL CONSTANT FREQUENCY RADARS		5. FUNDING NUMBERS	
6. AUTHOR Dimitrios N. Geladakis			
7. PERFORMING ORGANIZATION NAME(S) AND ADDRESS(ES) Naval Postgraduate School Monterey CA 93943-5000		8. PERFORMING ORGANIZATION REPORT NUMBER	
9. SPONSORING/MONITORING AGENCY NAME(S) AND ADDRESS(ES)		10. SPONSORING/MONITORING AGENCY REPORT NUMBER	
11. SUPPLEMENTARY NOTES The views expressed in this thesis are those of the author and do not reflect the official policy or position of the Department of Defense or the U.S. Government.			
12a. DISTRIBUTION/AVAILABILITY STATEMENT Approved for public release; distribution is unlimited.		12b. DISTRIBUTION CODE	
13. ABSTRACT (maximum 200 words) In this thesis, the Step Frequency radar system is compared with the conventional Constant Frequency radar system. The two radar systems are separately analyzed and their analyses are followed by a comparison which is mainly based upon their effectiveness to detect moving targets in clutter. The step frequency waveform consists of a series of pulses whose pulse width is constant and whose carrier frequency is linearly increased from pulse to pulse in steps. As compared to the conventional constant frequency radar waveforms, the step frequency waveform can achieve high range resolution while still retaining the advantages of lower instantaneous receiver bandwidth and lower analog-to-digital sampling rate at the expense, however, of more complex signal processing.			
14. SUBJECT TERMS Step Frequency Radar, Step Frequency Waveform, Constant Frequency Radar, Constant Frequency Waveform, High Range Resolution.		15. NUMBER OF PAGES 62	16. PRICE CODE
17. SECURITY CLASSIFICATION OF REPORT Unclassified	18. SECURITY CLASSIFICATION OF THIS PAGE Unclassified	19. SECURITY CLASSIFICATION OF ABSTRACT Unclassified	20. LIMITATION OF ABSTRACT UL

NSN 7540-01-280-5500

Standard Form 298 (Rev. 2-89)
Prescribed by ANSI Std. Z39-18 298-102

Approved for public release; distribution is unlimited

**COMPARISON OF THE STEP FREQUENCY RADAR
WITH THE CONVENTIONAL CONSTANT FREQUENCY RADARS**

Dimitrios N. Geladakis
Major, Hellenic Army
B.S., Hellenic Military Academy, 1980
B.S.E.E., National Polytechnic University of Athens "Metsovion", 1986

Submitted in partial fulfillment of the
requirements for the degree of

MASTER OF SCIENCE IN ELECTRICAL ENGINEERING

from the

**NAVAL POSTGRADUATE SCHOOL
December 1996**

Author: _____

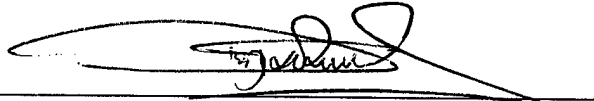

Dimitrios N. Geladakis

Approved by: _____

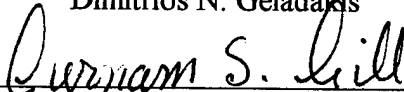

Gurnam S. Gill, Thesis Advisor



Phillip E. Pace, Second Reader

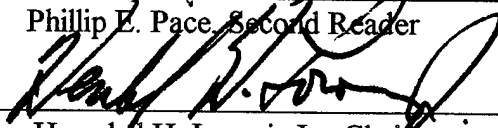

Herschel H. Loomis Jr., Chair

Department of Electrical and Computer Engineering

ABSTRACT

In this thesis, the Step Frequency radar system is compared with the conventional Constant Frequency radar system. The two radar systems are separately analyzed and their analysis is followed by a comparison which is mainly based upon their effectiveness to detect moving targets in clutter. The step frequency waveform consists of a series of pulses whose pulse width is constant and whose carrier frequency is linearly increased from pulse to pulse in steps. Compared to the conventional constant frequency radar waveforms, the step frequency waveform can achieve high range resolution while still retaining the advantages of lower instantaneous receiver bandwidth and lower analog-to-digital sampling rate at the expense, however, of more complex signal processing.

TABLE OF CONTENTS

I.	INTRODUCTION.....	1
II.	THE CONVENTIONAL CONSTANT FREQUENCY RADARS.....	3
	A. BLOCK DIAGRAM.....	3
	B. WAVEFORM MODEL.....	5
	C. IMPORTANT PARAMETERS.....	9
	1. Instantaneous Bandwidth.....	9
	2. Effective Bandwidth.....	9
	3. Range Resolution.....	9
	4. Maximum Unambiguous Range.....	10
	D. SIGNAL PROCESSING.....	11
III.	THE STEP FREQUENCY RADAR.....	17
	A. BLOCK DIAGRAM.....	17
	B. WAVEFORM MODEL.....	19
	C. IMPORTANT PARAMETERS.....	24
	1. Instantaneous Bandwidth.....	24
	2. Effective Bandwidth.....	24
	3. Range Resolution.....	25
	4. Maximum Unambiguous Range.....	28
	D. SIGNAL PROCESSING.....	30
IV.	SYSTEM COMPARISON.....	37
	A. SYSTEM IMPLEMENTATION.....	37
	B. SIGNAL PROCESSING.....	39
	C. CONCLUSION.....	43
	LIST OF REFERENCES.....	45

INITIAL DISTRIBUTION LIST.....47

LIST OF FIGURES

Figure 2.1.	Block Diagram of a Conventional Constant Frequency Radar.....	4
Figure 2.2.	Waveform of the Conventional Constant Frequency Radars.....	6
Figure 2.3.	Frequency Spectrum of the Constant Frequency Waveform.....	6
Figure 2.4.	Coherent Phase Detector.....	7
Figure 2.5.	Signal Processor of a Conventional Constant Frequency Radar.....	12
Figure 2.6.	Organization of N Collected Samples from a Target.....	13
Figure 2.7.	Doppler Filter Bank for N Pulses.....	14
Figure 3.1.	Block Diagram of the Step Frequency Radar.....	18
Figure 3.2.	Waveform of the Step Frequency Radar.....	21
Figure 3.3.	Frequency Spectrum of the Step Frequency Waveform.....	21
Figure 3.4.	Range Resolution with the Step Frequency Radar.....	26
Figure 3.5.	Signal Processor of the Step Frequency Radar.....	31
Figure 3.6.	Original Synthetic Range Profile with the Step Frequency Radar.....	36
Figure 3.7.	Final Synthetic Range Profile with the Step Frequency Radar.....	36

LIST OF TABLES

Table 4.1. Comparison of the Step Frequency Radar with the Conventional Constant Frequency Radars.....	42
---	----

ACKNOWLEDGEMENT

The author wishes to express his sincere gratitude toward Professor Gill for his invaluable advice and guidance in the preparation of this thesis. The author also extends his sincere thanks to Professor Pace for being kind enough to be the second reader.

I. INTRODUCTION

Pulse radar systems extract the Doppler frequency shift imparted on the reflected signal by moving targets to discriminate them from clutter. This Doppler shift appears as a change in the phase of the received signals between consecutive radar pulses which are transmitted in a sequence of N pulses. A coherent pulse radar system utilizes free-running highly-stable reference local oscillators for coherent transmission and reception, as well as coherent signal processing in order to reject the main-beam clutter, enhance the target detection, and aid in the target discrimination and classification.

If the radio frequency (RF) of each pulse is constant, then it is a conventional Constant Frequency radar, which can be either a Moving Target Indication (MTI) radar or a Pulse Doppler radar. However, if the radio frequency changes linearly from pulse to pulse in steps, then the system is a Step Frequency radar. Both radars use the Doppler principle for the detection of moving targets. The Step Frequency radar has some advantages over the conventional Constant Frequency radars, particularly when high range resolution (HRR) is desired. [Ref. 1]

High range resolution is sought in radars for reasons such as accurate range measurement, enhancement of the target-to-clutter ratio, resolution of multiple targets, target range profile and size, and target classification and recognition. High range resolution is achieved by using a large bandwidth. With conventional pulse compression, which is employed in Constant Frequency radars for high range resolution, the large bandwidth is obtained instantaneously through the modulation inside the pulse. The large

instantaneous bandwidth, though, requires a high analog-to-digital (A/D) sampling rate which may be difficult to obtain for a very high range resolution system. However, this technology bottleneck can be sidestepped by the step frequency waveform in which the large bandwidth is obtained sequentially by stepping the frequency of each pulse. By keeping the instantaneous bandwidth low, the requirements for the analog-to-digital sampling rates are considerably lower. Thus, the implementation of the step frequency waveform can achieve high range resolution with the distinct advantages of lower instantaneous receiver bandwidth and lower analog-to-digital sampling rate (both being the major limiting factors for achieving high range resolution with conventional Constant Frequency radars). However, these advantages are obtained at the expense of more complex signal processing. The step frequency waveform can be implemented on existing radar equipment with the addition of a step frequency synthesizer and suitable signal processing.

The purpose of this thesis is the comparison of the Step Frequency radar with the conventional Constant Frequency radars. The former is introduced in Chapter II and the latter is introduced in Chapter III. The comparison between the Step Frequency radar and the conventional Constant Frequency radars is based upon their effectiveness to detect moving targets in clutter and is described in Chapter IV.

II. THE CONVENTIONAL CONSTANT FREQUENCY RADARS

This chapter covers the important aspects of the conventional Constant Frequency radars, such as the block diagram, the model of the constant frequency waveform, the important parameters, and the signal processing, which will be used later in Chapter IV to compare the conventional Constant Frequency radars with the Step Frequency radar. The conventional Constant Frequency radars can be either Moving Target Indication or Pulse Doppler. The former employs low pulse repetition frequency (PRF), and is unambiguous in range and ambiguous in Doppler frequency. The latter, in general, employs high pulse repetition frequency, and is unambiguous in Doppler frequency and ambiguous in range. They are used in various applications including surveillance, interception, fire control, missile seeking, weapon control, and missile warning. [Ref. 2]

A. BLOCK DIAGRAM

A typical configuration for the Constant Frequency radar system is shown in Figure 2.1. It is the block diagram of a coherent Moving Target Indication radar with a power-amplifier transmitter. [Ref. 3]

In this configuration the coherent reference is supplied by the coherent oscillator (COHO). The frequency of this stable oscillator is the same as the intermediate frequency (IF) used in the receiver side of the radar system. The output of the coherent oscillator provides the reference signal and is mixed with the output of the stable local oscillator (STALO) to generate the transmitted frequency.

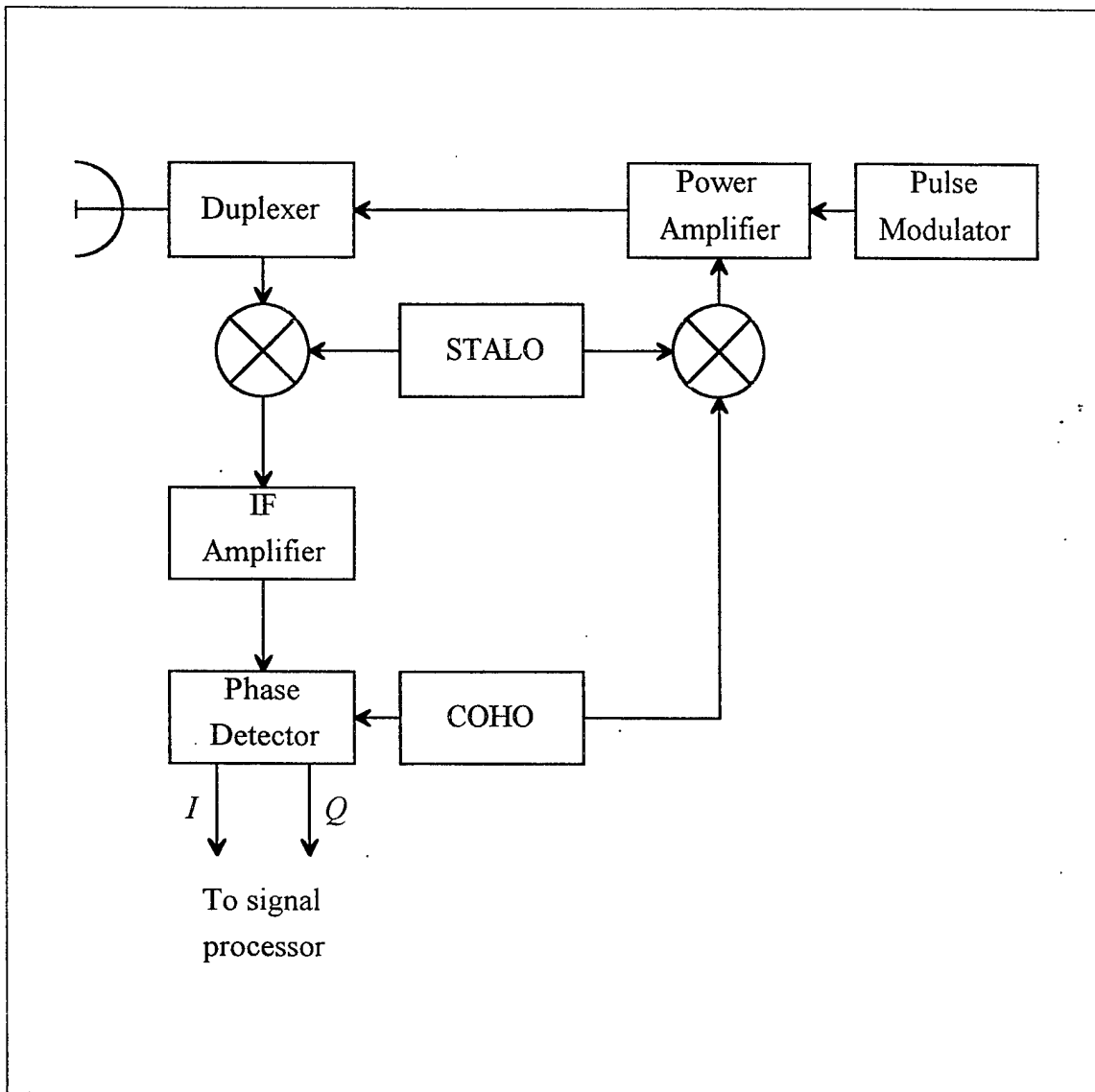

Figure 2.1. Block Diagram of a Conventional Constant Frequency Radar.

The received signal is heterodyned with the output of the stable local oscillator to produce the intermediate-frequency signal which is fed into an intermediate-frequency amplifier with bandwidth approximately equal to the inverse of the pulse width, centered on the frequency of the coherent oscillator.

In the transmitter, the stable local oscillator provides the necessary frequency translation from the frequency of the coherent oscillator to the final transmitted radio-frequency. The phase of the transmitted signal is influenced by the phase of the stable local oscillator and the phase of the coherent oscillator. However, any phase shift in these oscillators is canceled on reception since they also act as the local oscillators in the receiver.

The reference signal from the coherent oscillator and the amplified intermediate-frequency received signal are both fed into the coherent phase detector whose output is proportional to the phase difference between these two input signals.

B. WAVEFORM MODEL

Constant Frequency radars transmit sequences of N pulses at fixed pulse repetition frequency and at fixed carrier frequency. Each set of N pulses is called coherent processing interval (CPI) as the returns from these pulses will be coherently processed. Each pulse in the sequence has the same pulse width and the same carrier frequency. Figures 2.2 and 2.3 show a simplified pictorial representation of the constant frequency waveform and its frequency spectrum.

If the transmitted pulsed signal is:

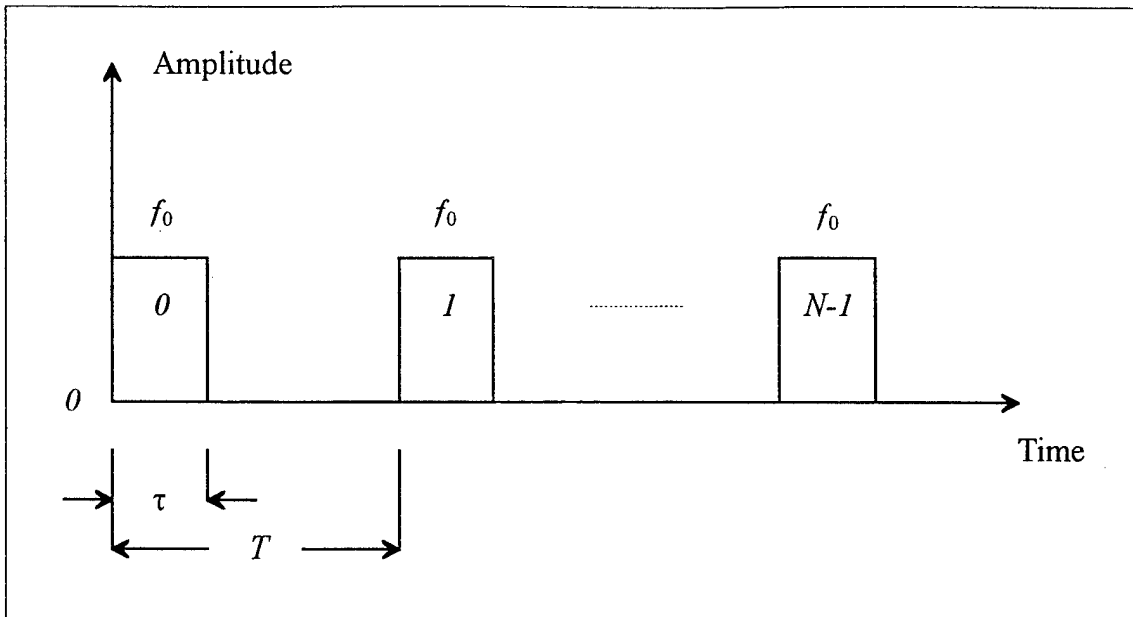

Figure 2.2. Waveform of the Conventional Constant Frequency Radars.

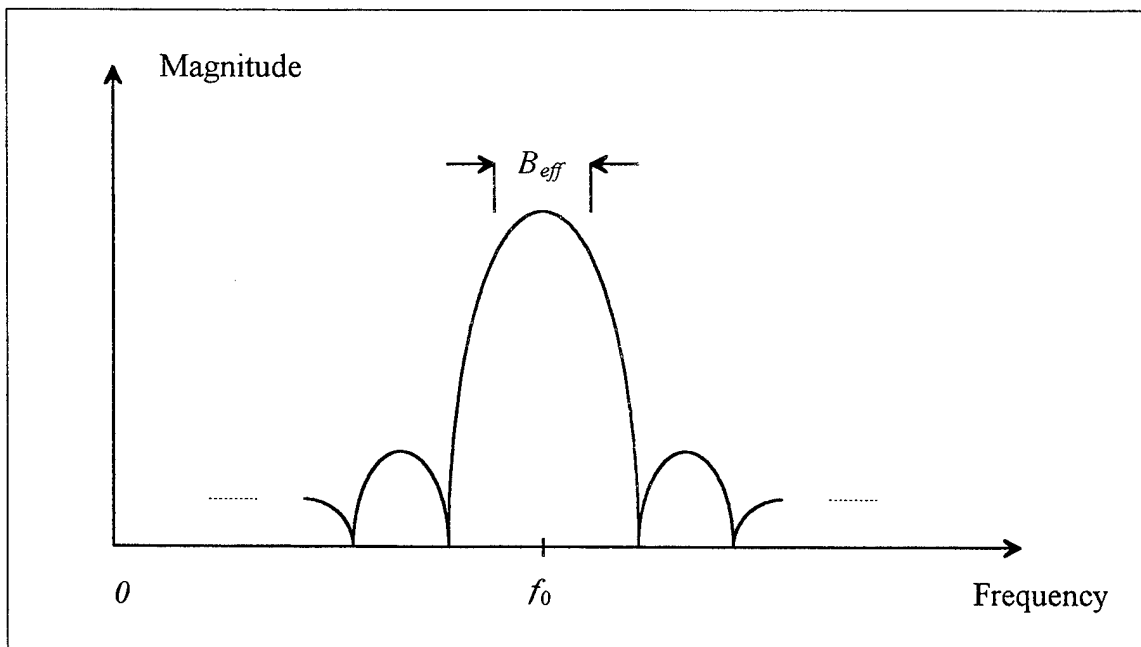

Figure 2.3. Frequency Spectrum of the Constant Frequency Waveform.

$$s_1(t) = A_1 \cos(2\pi f_0 t) \quad (2.1)$$

then the target signal received after a time delay of $2R/c$ is given by:

$$s_2(t) = A_2 \cos[2\pi f_0 (t - \frac{2R}{c})] \quad (2.2)$$

where R is the range to the target, which in general varies with time, and c is the velocity of light.

The output of the coherent phase detector is modeled as the product between the received signal and the reference signal followed by a lowpass filter, as shown in Figure 2.4 below.

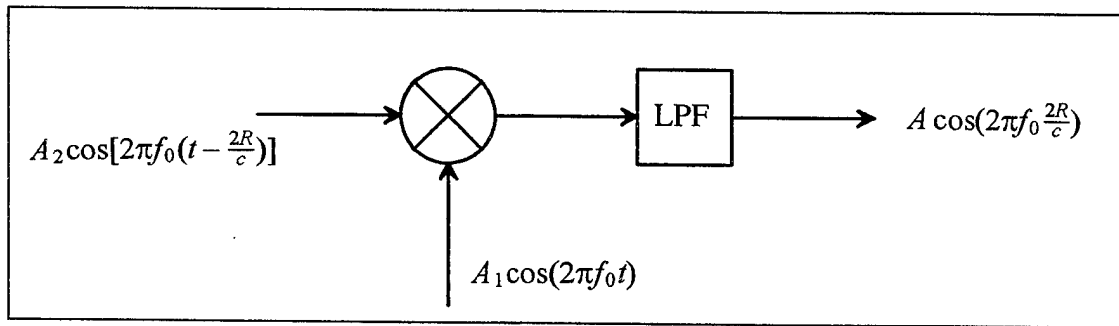

Figure 2.4. Coherent Phase Detector.

Then, the output of the mixer stage of the coherent phase detector is:

$$\begin{aligned} s_1(t)s_2(t) &= A_1 A_2 \cos(2\pi f_0 t) \cos[2\pi f_0 (t - \frac{2R}{c})] \\ &= \frac{A_1 A_2}{2} \{ \cos[2\pi(2f_0)t - 2\pi f_0 \frac{2R}{c}] + \cos(2\pi f_0 \frac{2R}{c}) \} \end{aligned} \quad (2.3)$$

The high-frequency component, the first term in the above equation, is filtered out by the lowpass filter stage. The output of the coherent phase detector is:

$$s(t) = \frac{A_1 A_2}{2} \cos(2\pi f_0 \frac{2R}{c}) \quad (2.4)$$

which may be written as:

$$s(t) = A \cos(2\pi f_0 \frac{2R}{c}) \quad (2.5)$$

For I - Q phase detector, the output can be represented as:

$$s(t) = A e^{-j\phi} \quad (2.6)$$

where:

$$\phi = 2\pi f_0 \frac{2R}{c} \quad (2.7)$$

If the target is moving at a constant velocity, v , the range changes with each pulse as:

$$R_n = R_0 + v n T \quad (2.8)$$

where T is the pulse repetition interval (PRI) in the sequence of pulses and $n=0,1,2,\dots,N-1$.

From the Equations 2.7 and 2.8, the phase of the target is obtained as:

$$\phi_n = 2\pi f_0 \frac{2}{c} (R_0 + v n T) \quad (2.9)$$

The above equation can be rewritten as:

$$\begin{aligned} \phi_n &= \frac{4\pi f_0 R_0}{c} + 2\pi \frac{2v}{c} f_0 n T \\ &= \phi_0 + 2\pi \frac{2v}{\lambda} n T \end{aligned} \quad (2.10)$$

where λ is the wavelength of the carrier signal.

The first component in the last equation represents a constant phase shift which is not of any practical significance. The second component represents the traditional Doppler frequency shift due to target motion.

C. IMPORTANT PARAMETERS

Some of the parameters which are important in both the design and performance of a conventional Constant Frequency radar, are discussed in this section.

1. Instantaneous Bandwidth

The instantaneous bandwidth of the waveform is approximately equal to the inverse of the pulse width:

$$B_{ins} = \frac{1}{\tau} \quad (2.11)$$

2. Effective Bandwidth

Effective bandwidth is the square root of the normalized second moment of the magnitude of the spectrum of the pulse, to the power of two, about the mean which is taken to be at zero frequency. The effective bandwidth is not simply related to either the half-power bandwidth or the noise bandwidth. The larger the value of the effective bandwidth, the more accurate the range measurement is. The effective bandwidth for the constant frequency waveform, is the same as the instantaneous bandwidth:

$$B_{eff} = B_{ins} = \frac{1}{\tau} \quad (2.12)$$

3. Range Resolution

The range resolution depends upon the instantaneous bandwidth as given by:

$$\Delta r = \frac{c}{2B_{ins}} \quad (2.13)$$

Since the effective bandwidth equals the instantaneous bandwidth, the range resolution achieved with the constant frequency waveform consisting of unmodulated pulses, is the conventional range resolution given by:

$$\Delta r = \frac{c\tau}{2} \quad (2.14)$$

4. Maximum Unambiguous Range

Once a transmitted pulse is emitted by a radar, sufficient length of time must elapse to allow any echo signals to return and be detected before the next pulse may be transmitted. Therefore the rate at which the pulses may be transmitted is determined by the longest range at which targets are expected. If the pulse repetition frequency is too high, echo signals from some targets might arrive after the transmission of the next pulse, and ambiguities in measuring the range might result. The echoes which arrive after the transmission of the next pulse are called second-time-around echoes or, for the more general case, multiple-time-around echoes. Such an echo would appear to be at a much shorter range than the actual and could be misleading if it were not known to be a second-time-around echo. The range beyond which the targets appear as second-time-around echoes is the maximum unambiguous range. The maximum unambiguous range achieved with the constant frequency waveform is:

$$R_u = \frac{cT}{2} \quad (2.15)$$

D. SIGNAL PROCESSING

The signal processor for the conventional Constant Frequency radars is shown in Figure 2.5. The received doppler-shifted echo signal from a moving target is down-converted to an intermediate frequency, amplified, and fed into the coherent phase detector. For the purpose of eliminating the effects of blind phases, at the input of the phase detector the signal is split into two channels, the in-phase (I) channel and the quadrature (Q) channel. For the in-phase channel the signal is mixed directly with the output of the coherent oscillator, whereas for the quadrature channel the signal is mixed with the output of the coherent oscillator after a 90-degree phase shift has been introduced into the latter. This causes the two outputs from the coherent phase detector to be 90 degrees out of phase; thus, their combination results in a uniform signal with no loss.

The bipolar video output from the coherent phase detector is fed into the analog-to-digital converter. The converter samples and quantizes the incoming signal. Each voltage sample is a complex number of the form $I+jQ$.

The digital words are stored in the memory until all the pulses from one coherent processing interval have been received and can be processed. The received data are sorted by range bins. Each range bin is processed separately. The organization of the N collected samples is shown in Figure 2.6.

Prior to forming a Doppler-filter bank, weighting of the returns from the target is performed by multiplying the target signal with a weighted function. This procedure is repeated for every range bin. The weighting is applied because the Doppler-filter bank is

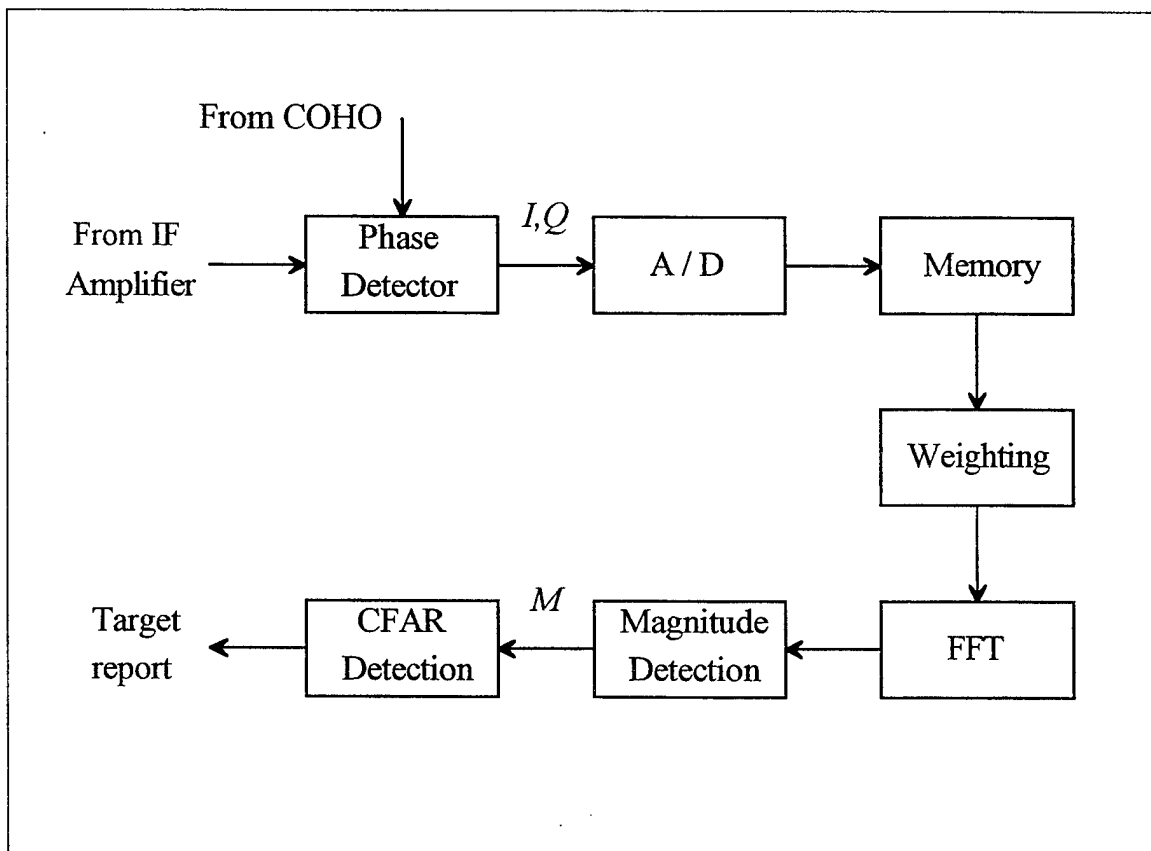

Figure 2.5. Signal Processor of a Conventional Constant Frequency Radar.

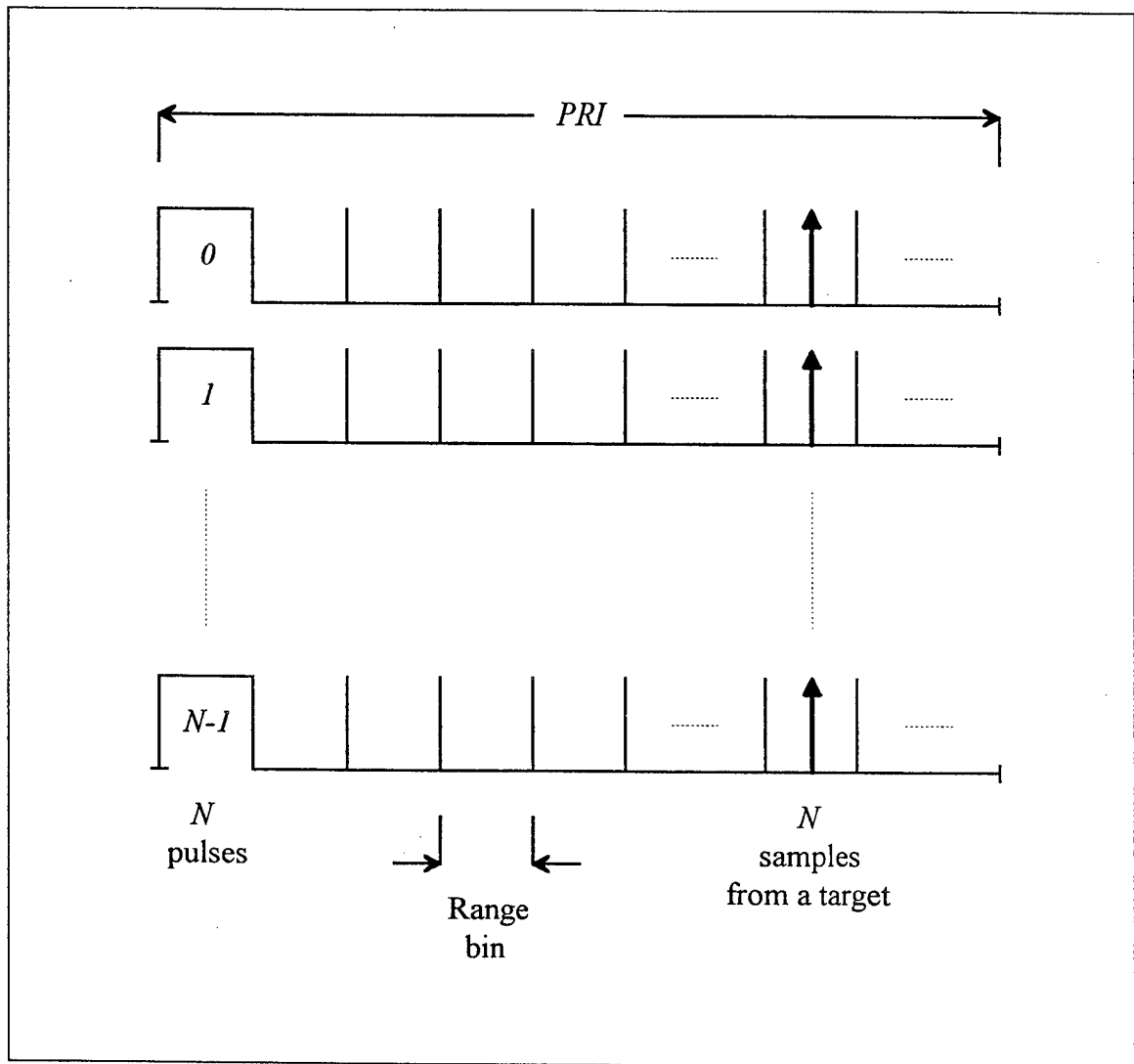

Figure 2.6. Organization of N Collected Samples from a Target.

composed of non-ideal bandpass filters (BPF) whose sidelobe gains need to be kept as low as possible.

The N pulses are coherently processed by forming N overlapping Doppler filters covering the Doppler interval equal to one pulse repetition frequency. The fast Fourier transform (FFT) algorithm is used to implement the Doppler-filter bank. A simplified pictorial representation of the filters, which does not include their sidelobes, is shown in Figure 2.7. Each filter in the bank has a bandwidth of $2/NT$ as measured between the first nulls. The filters are spaced at intervals of $1/NT$ or PRF/N . The dividing of the frequency band into N independent parts by the N filters allows a measurement of the Doppler frequency.

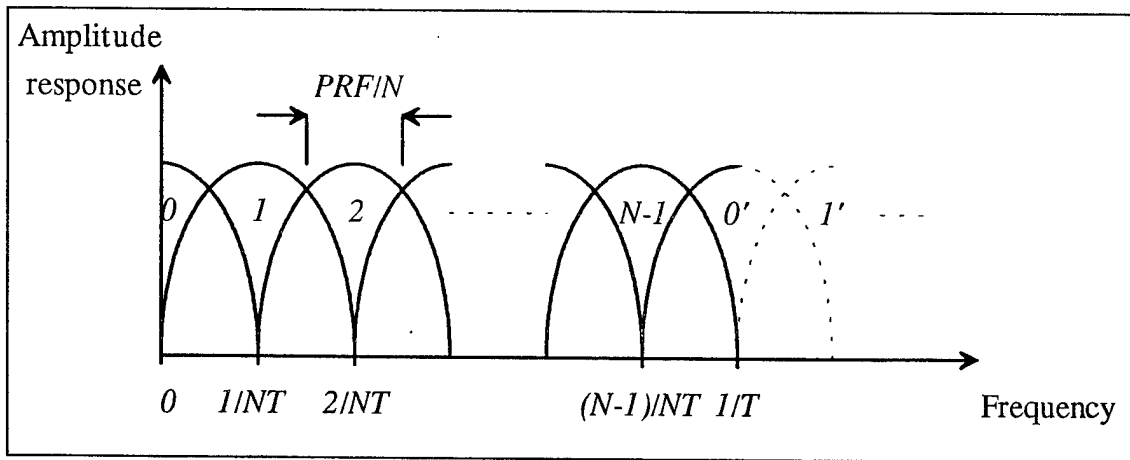

Figure 2.7. Doppler Filter Bank for N Pulses.

A magnitude operation follows, for the calculation of the magnitude M of each voltage sample, $I+jQ$, which is given by:

$$M = \sqrt{I^2 + Q^2} \quad (2.16)$$

Each one of the range-Doppler cells has its own adaptive threshold. These separate thresholds are applied to each filter in the Doppler-filter bank and they are individually adjusted so as to adapt to the clutter which is contained within each filter. The thresholds are established by summing the detected outputs of the signals in the same Doppler filter in a number of range bins centered around the range bin of interest. Thus, each filter output is averaged in range to establish the statistical mean level of clutter. The thresholds of the filters are determined by multiplying the mean levels by an appropriate constant to obtain the desired false-alarm probability. This application of an adaptive threshold to each Doppler filter at each range bin provides a constant false alarm rate (CFAR). The constant false alarm rate is necessary because, in general, the environment in which the target is detected, changes. There are changes in the radio-frequency environment, such as external noise, clutter, and jamming, as well as changes in the conditions of the equipment, such as the receiver gain and the receiver noise. In a changing radar environment, the output of the detector changes as well. A fixed threshold will result in an increase of the false alarm rate or loss of the target detectability. An increase in clutter and/or noise, generally increases the false alarm rate exponentially. Thus, to avoid an excessive false alarm rate or loss of targets, an adaptive threshold is established, so that the false alarm rate stays constant.

The output of the signal processor is a target report containing the azimuth, range, and amplitude of the target return as well as the filter number and pulse repetition frequency.

III. THE STEP FREQUENCY RADAR

The Step Frequency radar [Ref. 4] is described in this chapter, which includes the block diagram, the model of the step frequency waveform, the important parameters, and the signal processing of the system. The material of this chapter will be used for the comparison of the Step Frequency radar with the conventional Constant Frequency radars, in Chapter IV. The Step Frequency radar has been used for detailed radar cross section (RCS) measurements in anechoic chambers and open ranges. However, in the following discussion the Step Frequency radar is used for detection of moving targets in clutter.

A. BLOCK DIAGRAM

The implementation of the Step Frequency radar is as shown in Figure 3.1. The coherent step frequency synthesizer generates an output which is stepped in frequency from pulse to pulse by a fixed step size.

In the transmitter side, the output of the coherent oscillator is mixed with the output of the step frequency synthesizer (up-conversion). The sum of these two frequencies is converted to the final transmitted frequency by mixing it with the frequency of the stable local oscillator. The sum frequency of this second mixer is then pulse-modulated and amplified before the transmission occurs.

Each transmitted pulse has a carrier frequency comprised of three different components: the fixed intermediate frequency of the coherent oscillator, the fixed radio

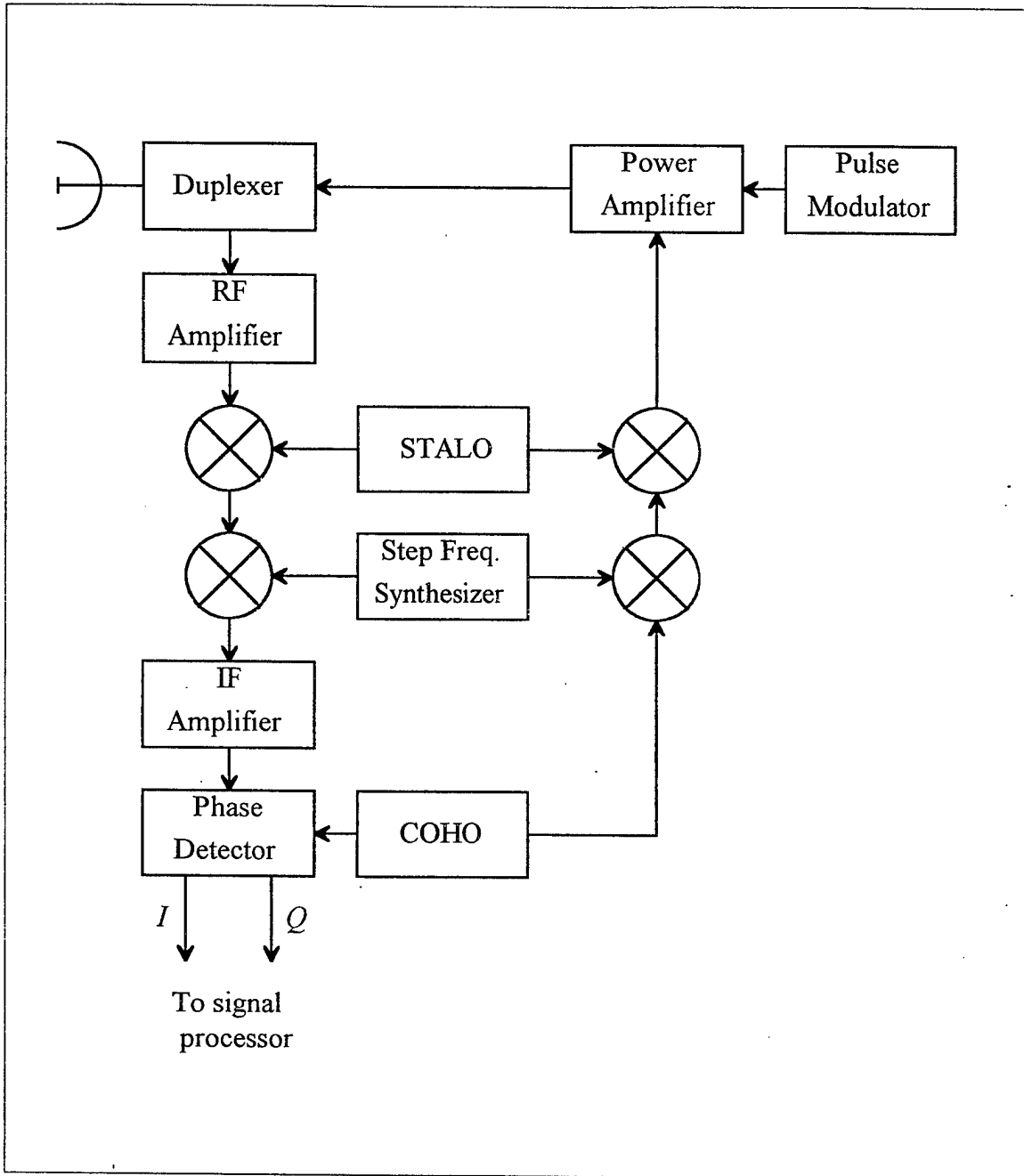

Figure 3.1. Block Diagram of the Step Frequency Radar.

frequency of the stable local oscillator, and the variable frequency of the step frequency synthesizer.

In the receiver side, the return radio-frequency target signal is amplified and down-converted by first mixing it with the output of the stable local oscillator. The resulting signal is further down-converted to intermediate frequency by mixing it with the output of the step frequency synthesizer.

The step frequency synthesizer is synchronized with the transmitter to allow the transmitted carrier frequency and the output of the step frequency synthesizer to use the same step frequency in the same pulse repetition interval. This allows the multiple-time-around clutter to be filtered out, as it will lie outside the passband of the intermediate-frequency amplifier.

The output signal obtained after the second mixer is the intermediate-frequency signal which is fed into the coherent phase detector through an intermediate-frequency amplifier with bandwidth approximately equal to the inverse of the pulse width, centered on the frequency of the coherent oscillator.

B. WAVEFORM MODEL

The step frequency waveform is an interpulse version of pulse compression techniques employed in conventional high resolution radars. The Step Frequency radar transmits sequences of N pulses at a fixed pulse repetition frequency but not at a fixed radar frequency. Each set of N pulses is called a coherent processing interval.

A simplified pictorial representation of the step frequency waveform is shown in Figure 3.2, and a representation of its frequency spectrum is shown in Figure 3.3. Each pulse in the sequence has the same pulse width but different carrier frequency. The carrier frequency of the pulses is linearly increased from pulse to pulse by a fixed increment. The frequency of the first pulse is the nominal carrier frequency, the frequency of the second pulse equals the nominal carrier frequency increased by the frequency step size, the frequency of the third pulse equals the nominal carrier frequency increased by twice the frequency step size, and so on. Thus, for the n -th transmitted pulse in the sequence, with $n=0, 1, 2, \dots, N-1$, the carrier frequency is given by:

$$f_n = f_0 + n\Delta f \quad (3.1)$$

If the transmitted pulsed signal for the n -th pulse is:

$$s_1(t) = A_1 \cos[2\pi(f_0 + n\Delta f)t] \quad (3.2)$$

then the target signal received after a time delay of $2R/c$ is given by:

$$s_2(t) = A_2 \cos[2\pi(f_0 + n\Delta f)(t - \frac{2R}{c})] \quad (3.3)$$

where R is the range to the target, which in general varies with time, and c is the velocity of light.

The output from the coherent phase detector is modeled as the product of the received signal with the reference signal followed by a lowpass filter, as was the case for the conventional Constant Frequency radar system. The output of the mixer stage of the coherent phase detector is:

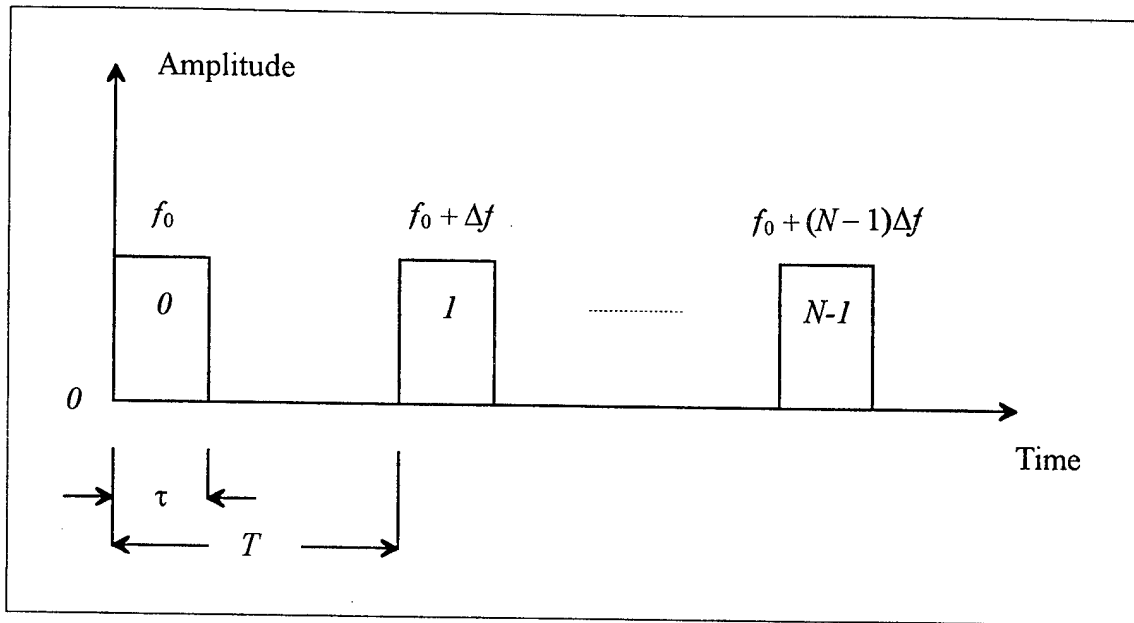

Figure 3.2. Waveform of the Step Frequency Radar.

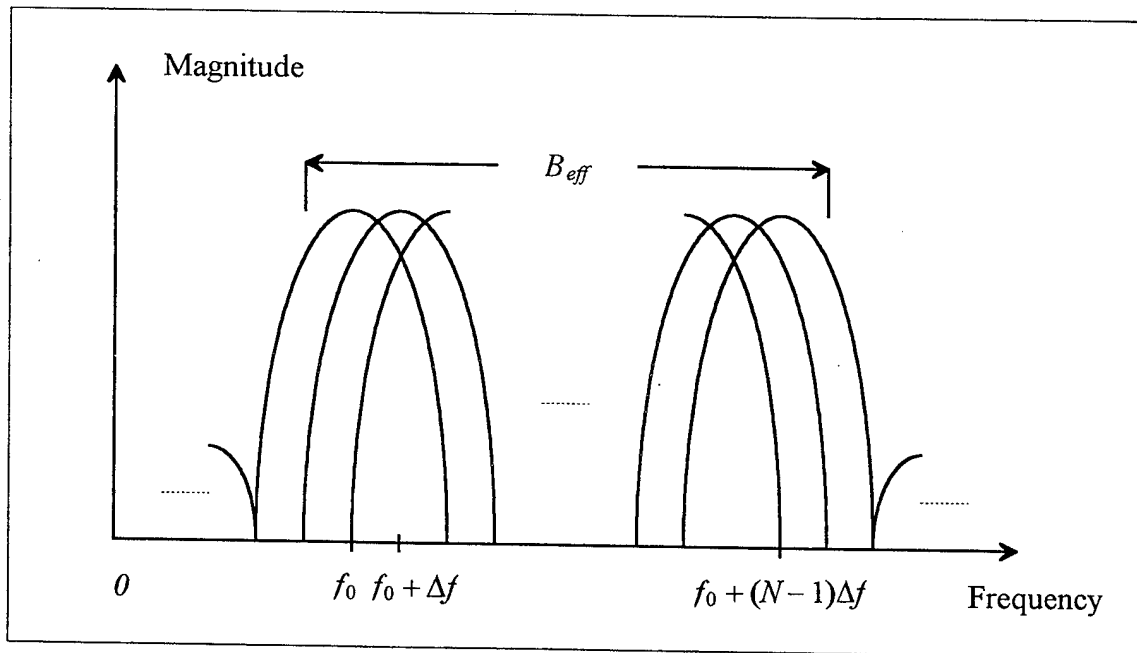

Figure 3.3. Frequency Spectrum of the Step Frequency Waveform.

$$\begin{aligned}
s_1(t)s_2(t) &= A_1A_2\cos[2\pi(f_0 + n\Delta f)t]\cos[2\pi(f_0 + n\Delta f)(t - \frac{2R}{c})] \\
&= \frac{A_1A_2}{2}\{\cos[2\pi 2(f_0 + n\Delta f)t - 2\pi(f_0 + n\Delta f)\frac{2R}{c}] + \cos[2\pi(f_0 + n\Delta f)\frac{2R}{c}]\} \quad (3.4)
\end{aligned}$$

The high-frequency component, the first term in the above equation, is filtered out by the lowpass filter stage. The output of the coherent phase detector is:

$$s(t) = \frac{A_1A_2}{2} \cos[2\pi(f_0 + n\Delta f)\frac{2R}{c}] \quad (3.5)$$

which may be written as:

$$s(t) = A \cos[2\pi(f_0 + n\Delta f)\frac{2R}{c}] \quad (3.6)$$

For I - Q phase detector, the output can be represented as:

$$s(t) = Ae^{-j\phi_n} \quad (3.7)$$

where:

$$\phi_n = 2\pi(f_0 + n\Delta f)\frac{2R}{c} \quad (3.8)$$

If the target is moving at a constant velocity, v , the range changes with each pulse as:

$$R_n = R_0 + vnT \quad (3.9)$$

where T is the pulse repetition interval in the sequence of pulses.

From the Equations 3.8 and 3.9, the phase of the target is obtained as:

$$\phi_n = 2\pi(f_0 + n\Delta f)\frac{2}{c}(R_0 + vnT) \quad (3.10)$$

The above equation can be rewritten as:

$$\phi_n = \frac{4\pi f_0 R_0}{c} + 2\pi \frac{\Delta f 2R_0}{T c} nT + 2\pi \frac{2v}{c} f_0 nT + 2\pi \frac{\Delta f 2vnT}{T c} nT \quad (3.11)$$

The first component in the last equation represents a constant phase shift which is not of any practical significance. The second component represents the frequency shift due to the frequency rate of change:

$$\dot{f} = \frac{\Delta f}{T} \quad (3.12)$$

multiplied by the round-trip delay time:

$$t_0 = \frac{2R_0}{c} \quad (3.13)$$

It is this component of the phase of the output of the coherent phase detector which gives finer range resolution in systems using the step frequency waveform.

The third component in Equation 3.11 represents the traditional Doppler frequency shift due to the motion of the target. The Doppler shift adds to the range frequency shift in the second component. The pulse compression, or range resolution, process interprets the Doppler frequency shift as due to range and thus the range of the moving target is shifted in the processing for achieving the synthetic range profile. The target position in terms of the number of processed range bins, is shifted by L synthetic range bins, where L is:

$$L = \frac{2vTf_0}{cN} \quad (3.14)$$

The fourth component in Equation 3.11 is the frequency shift where it changes from pulse to pulse and results in dispersion of the range profile and loss of target signal strength due to this spreading in range. The amount of dispersion of the range profile is determined as:

$$P = \frac{vNT}{\Delta r} \quad (3.15)$$

where P represents the number of the synthetic range bins that the target signal spreads in the range profile during the coherent processing interval. The spreading of the target signal results in loss of synthetic range resolution since the target signal is broadened from one synthetic range cell up to several synthetic range cells.

C. IMPORTANT PARAMETERS

Following is the discussion about the parameters which are important in the design as well as the analysis of the Step Frequency radar, as was the case for the conventional Constant Frequency radars. [Ref. 5]

1. Instantaneous Bandwidth

The instantaneous bandwidth of the waveform is the same as for the single pulse. It approximately equals the inverse of the pulse width:

$$B_{ins} = \frac{1}{\tau} \quad (3.16)$$

2. Effective Bandwidth

The effective bandwidth of this system, as it can be also verified by Figure 3.3, is given by:

$$B_{eff} = N\Delta f \quad (3.17)$$

3. Range Resolution

Due to the linear modulation of the pulses in the step frequency waveform the range is resolved by resolving the frequency shift. The range resolution achieved by coherently processing the series of N returns from a target depends upon the effective bandwidth and is given by:

$$\Delta r = \frac{c}{2B_{eff}} = \frac{c}{2N\Delta f} \quad (3.18)$$

The above result shows that the range resolution can be improved by increasing either the number of pulses in the sequence or the frequency step size.

The step frequency waveform decreases the range resolution cell since it subdivides the original (conventional) range bin into smaller parts. This is done by taking the fast Fourier transform of the N samples, from N pulses, from a range bin. The resulting output is the high resolution range profile of the range bin. The fast Fourier transform divides the maximum unambiguous range into N equal parts. The range resolution of the resulting profile can then be written as:

$$\Delta r = \frac{R_u}{N} = \frac{c}{2N\Delta f} = \frac{c\tau/2}{N\tau\Delta f} \quad (3.19)$$

The final step in the last equation shows the number of parts which the original range bin is divided into, as a result of the fast Fourier transform. A simplified pictorial representation of the division of both the original range bin and the maximum unambiguous range, which is discussed in the following sub-subsection, into a different number of range bins, is shown in Figure 3.4 below. Thus, the size of the resulting processing range cell, or range resolution, depends upon the product of the pulse width

and the frequency step size. This is the reason for the pulse width and the frequency step size to be the primary parameters in the design of the Step Frequency radar system.

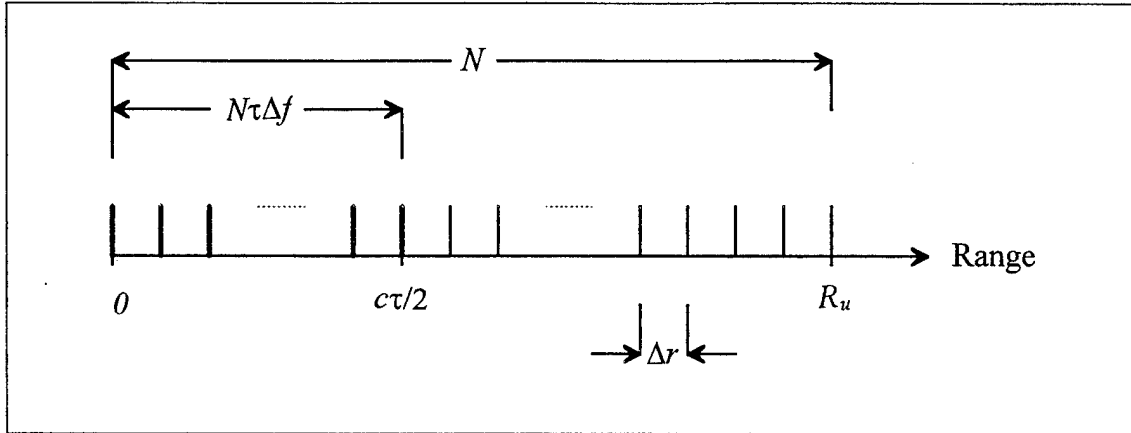

Figure 3.4. Range Resolution with the Step Frequency Radar.

Depending upon the original range bin width as compared to the maximum unambiguous range, there are three cases for the possible values of the product between the pulse width and the frequency step size:

- (1) The original range bin equals the maximum unambiguous range.

This also translates to:

$$\tau\Delta f = 1 \quad (3.20)$$

In this case the original range bin is also divided into N equal parts. The clutter and the target coexist in the range cell and there is no clutter-free space available for the moving target to move out to. Target wraparound caused by slight changes in the target range is difficult to notice. Furthermore, aliasing may occur if there is interference from adjacent

range bins. If the original range bin encompasses the target and the clutter, the target is camouflaged by the clutter. This situation may be acceptable for a stationary target but is undesirable for detection of moving targets, and is only effective for target detection in a non-clutter environment.

(2) The original range bin is greater than the maximum unambiguous range. This also translates to:

$$\tau\Delta f > 1 \quad (3.21)$$

In this case the number L of the synthetic range bins which determines the shifted position of the target, is greater than the number of the fast Fourier transform bins, N , and the target signal in the range profile is circularly shifted resulting in a wraparound and distortion of itself in the process. Thus, the primary step frequency waveform parameters must be properly chosen for the above product not to be greater than unity.

(3) The original range bin is shorter than the maximum unambiguous range. This also translates to:

$$\tau\Delta f < 1 \quad (3.22)$$

In this case the original range bin comprises only a small fraction of the maximum unambiguous range window. The maximum unambiguous range is subdivided into N equal parts and the original range bin is divided into a smaller number of parts, which is:

$$N\tau\Delta f < N \quad (3.23)$$

This means that the processed range resolution is poorer. However, the advantage is that beyond the range equal to the original range bin, on the high resolution range profile, there is space available for targets to move out of the clutter since this portion of the profile is unused and free of clutter, and can be used for the detection of the shifted target signal.

The above discussion demonstrates how critical the selection of the pulse width and frequency step size is for the Step Frequency radar system performance. The selection of the former depends upon the maximum target extent, E , whereas the selection of the latter depends upon the requirement for avoidance of target wraparound. Good target detectability requires that the pulse width must encompass the maximum target extent. This means that the pulse width must be greater than the round trip time for length E :

$$\tau > \frac{2E}{c} \quad (3.24)$$

If the pulse width cannot encompass the target extent in range, different scatterers on a target will not be located within the same original range bin, resulting in a loss of the signal-to-noise ratio (SNR) and an incomplete high resolution range profile. For choosing the frequency step size, the requirement is that the maximum unambiguous range window must encompass the maximum target extent E . That is:

$$R_u = \frac{c}{2\Delta f} > E, \quad \text{or} \quad \Delta f < \frac{c}{2E} \quad (3.25)$$

4. Maximum Unambiguous Range

With the step frequency waveform, high range resolution is achieved by generating a phase shift by means of linear changes in the carrier frequencies of the pulses.

The induced phase shift due to the frequency change from pulse to pulse is given by the second term in the expression derived for the phase of the signal at the output of the coherent phase detector (Equation 3.11):

$$\phi_{ind} = 2\pi \frac{\Delta f 2R_0}{T c} nT \quad (3.26)$$

The induced frequency shift is obtained from this equation by determining the rate of the phase change as:

$$f_{ind} = \frac{\Delta f 2R_0}{T c} \quad (3.27)$$

The maximum unambiguous range is obtained by substituting the maximum induced frequency shift in the above equation, equal to the pulse repetition frequency:

$$\frac{\Delta f 2R_u}{T c} = PRF = \frac{1}{T} \quad (3.28)$$

From the last equation, the maximum unambiguous range in the high resolution range profile is:

$$R_u = \frac{c}{2\Delta f} \quad (3.29)$$

Therefore, the fraction of the window corresponding to the maximum unambiguous range, which is occupied by an original range cell, is (Figure 3.4):

$$\frac{\Delta r}{R_u} = \frac{c\tau/2}{c/2\Delta f} = \tau\Delta f \quad (3.30)$$

D. SIGNAL PROCESSING

Figure 3.5 shows a signal processor for the Step Frequency radar. The first stages of it are the same as the first stages of the signal processor of the conventional Constant Frequency radars.

The received Doppler-shifted echo signal from a moving target is down-converted to intermediate frequency, amplified, and fed into the coherent phase detector. For the purpose of eliminating the effects of blind phases, at the coherent phase detector the signal is split into two channels, the in-phase channel and the quadrature channel, by mixing with the reference signal from the coherent oscillator. For the in-phase channel the signal is mixed directly with the output of the coherent oscillator, whereas for the quadrature channel the signal is mixed with the output of the coherent oscillator after a 90-degree phase shift has been introduced into the latter. This causes the two outputs from the coherent phase detector to be 90 degrees out of phase; thus, their combination results in a uniform signal with no loss.

The bipolar video output from the coherent phase detector is fed into the analog-to-digital converter. In the converter, the signal is sampled to obtain one sample within each range bin, quantized, and converted into a series of digital words. Each voltage sample is a complex number of the form $I+jQ$.

The digital words are stored in the memory until all the pulses from one coherent processing interval have been received and can be processed. The received data are sorted by range bins. Each range bin is processed separately. The organization of the storage of samples in the memory is the same as for the Constant Frequency radars (Figure 2.6).

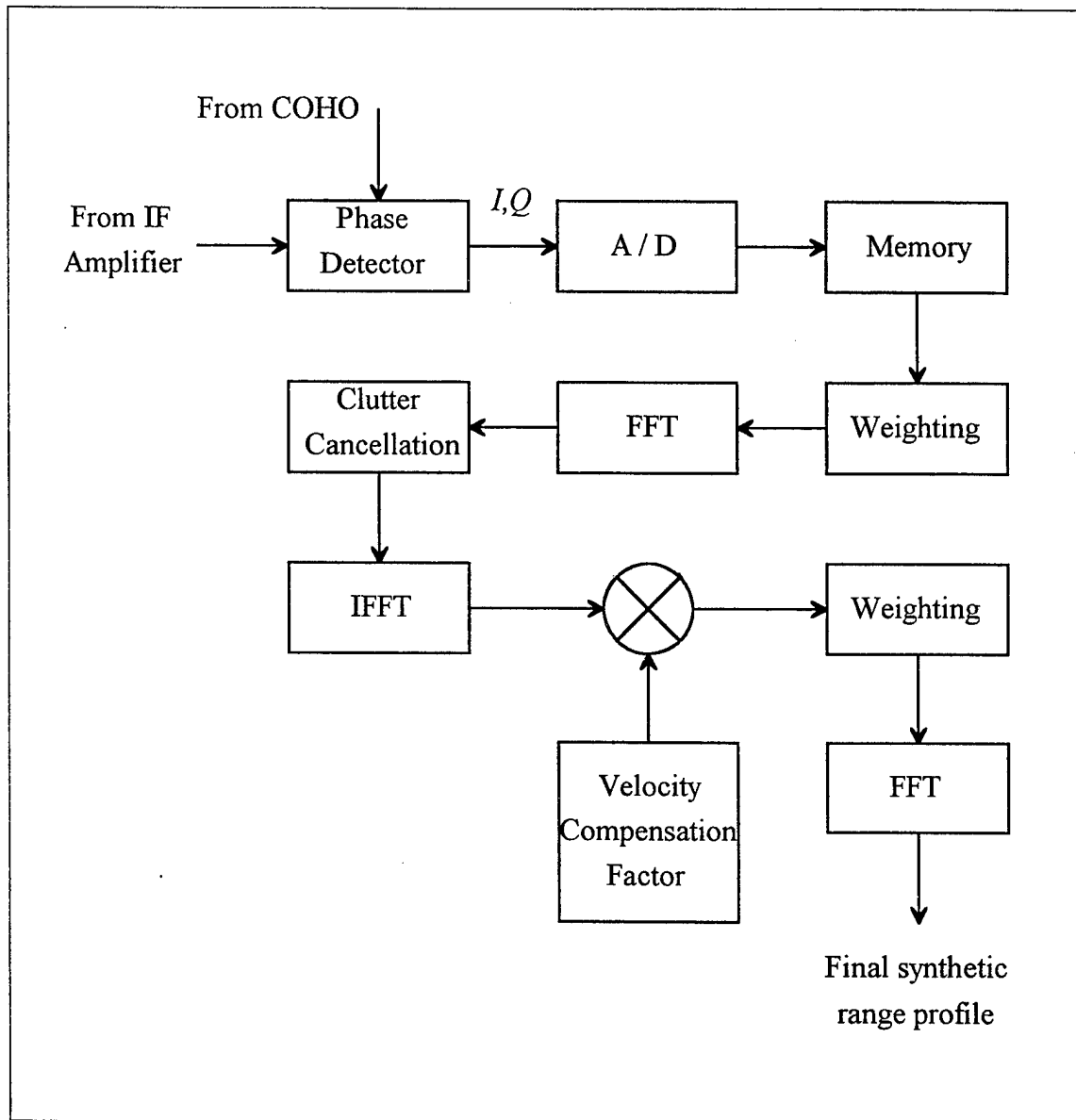

Figure 3.5. Signal Processor of the Step Frequency Radar.

Prior to forming a Doppler-filter bank, weighting is performed by multiplying the target signal with a weighted function to reduce the filter sidelobes. The weighting suppresses the range sidelobes of the profile, but also causes degradation of the resolution.

The N pulses are coherently processed by forming N overlapping Doppler filters with a total response covering the Doppler interval equal to one pulse repetition frequency. The fast Fourier transform algorithm is used to implement the Doppler-filter bank. Each filter in the bank has a bandwidth of $2/NT$ as measured between the first nulls. Because of the sampled nature of the signals, the remainder of the frequency band is also covered with overlapping filters as shown in Figure 2.7. The dividing of the frequency band into N independent parts by the N filters allows a measure of the Doppler frequency to be made.

Initial high resolution range profile is obtained at the output of the Doppler-filter bank. The high range resolution processing may be used for a target range bin or for the entire radar range. However, in this writing, range profiling of one coarse range bin is assumed. The absolute range of the target is not shown; only the relative ranges within the range bin are indicated. The fast Fourier transform coefficients can be interpreted as the relative synthetic range cells which finely resolve the coarse range cell. The same procedure for obtaining the high resolution range profile can be applied to all other range bins.

The fast Fourier transform acts as a matched filter when there is no relative radial motion between the radar and the target. Relative radial motion during the coherent processing interval results in nonlinear phase shifts in the received signal. As a result, the

fast Fourier transform processing is not matched to the received Doppler-shifted target returns, and leads to a distorted range profile. The distortion includes target spreading, shifting, and attenuation in the range profile. The target spreading and attenuation affect the radar performance adversely by degrading the range resolution and decreasing the signal-to-noise ratio. The target spreading factor, P , determines the number of the synthetic range bins occupied by the moving target in the range profile. Instead of the theoretical resolution, the effective synthetic resolution for a moving target is:

$$\Delta r_{eff} = P\Delta r \quad (3.31)$$

In addition to the loss of range resolution, excessive target shift due to the relative radial velocity may result in target wraparound. The number of the synthetic range bins that the moving target shifts in the range profile is equal to the target shifting factor, L .

With the fast Fourier transform processing, the moving target shifts from the clutter-filled region to the clutter-free region in the high resolution range profile, if the parameters of the step frequency waveform are appropriately chosen (Equation 3.22). Figure 3.6 shows how the original synthetic range profile looks like after the application of the fast Fourier transform algorithm. The position of the target in the processed range profile is found by measuring the number L of the synthetic range bins up to the center value of the target profile. The velocity of the target is then calculated from Equation 3.14:

$$v = \frac{LcN}{2Tf_0} \quad (3.32)$$

The clutter always occupies data points within the range bin. Since the clutter and the target are differentiated by the fast Fourier transform, the former is easily eliminated by applying clutter cancellation to the original range profile.

The inverse fast Fourier transform (IFFT) algorithm is applied to the range profile at the output of the clutter cancellation stage in order to convert the modified range profile into frequency domain data which are then mixed with a velocity compensation factor.

Application of velocity compensation [Ref. 6] to the received signal, based on the target velocity, restores the range resolution. Straightforward application, though, of velocity compensation to the received signal, simply compensates the target signal but the clutter spreads in the range profile due to unnecessary compensation velocity. Thus, the received signal is compensated in phase. This procedure eliminates the effects of the relative radial velocity. The phase compensation depends upon the calculated target velocity (Equation 3.32) and is normally termed as velocity compensation factor. Since the shifting and dispersion problems of the stepped-frequency returns can be resolved by eliminating the frequency shift caused by the target motion, that is the third and fourth components in the expression derived for the phase of the output of the phase detector (Equation 3.11), then the velocity compensation factor consists of these components with a 180-degree phase rotation as given by:

$$comp(n) = \exp[-j\frac{4\pi}{c}v(f_0 + n\Delta f)nT] \quad (3.33)$$

With the application of the velocity compensation factor to the received radar signal, the compensated signal is:

$$c(n) = A \exp(j\phi_n)\exp[-j\frac{4\pi}{c}v(f_0 + n\Delta f)nT] \quad (3.34)$$

Weighting is applied to the compensated signal. The resulting signal is transformed into the final range profile by using the fast Fourier transform algorithm. A pictorial representation of the final synthetic range profile is shown in Figure 3.7.

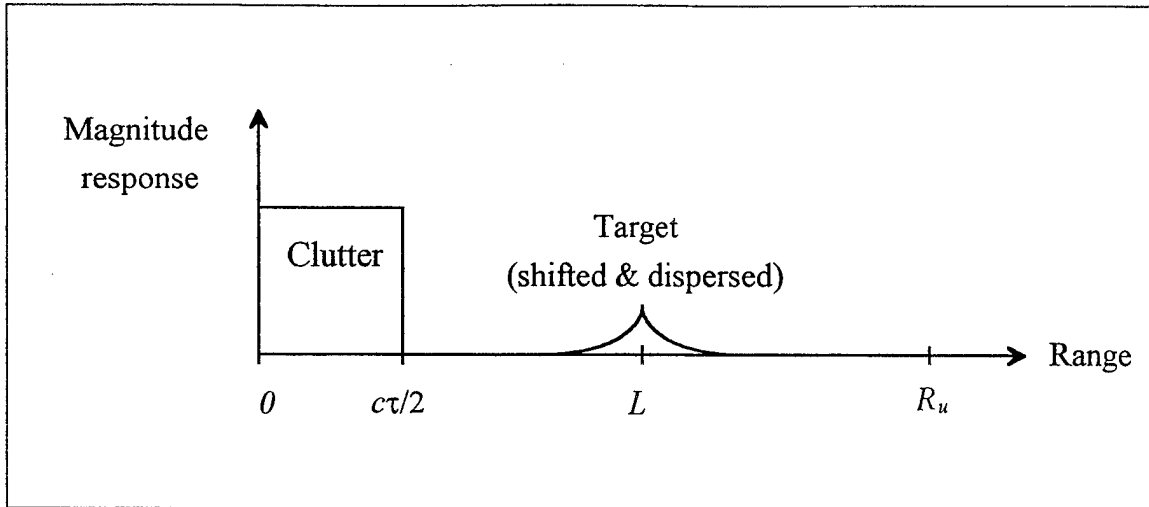

Figure 3.6. Original Synthetic Range Profile with the Step Frequency Radar.

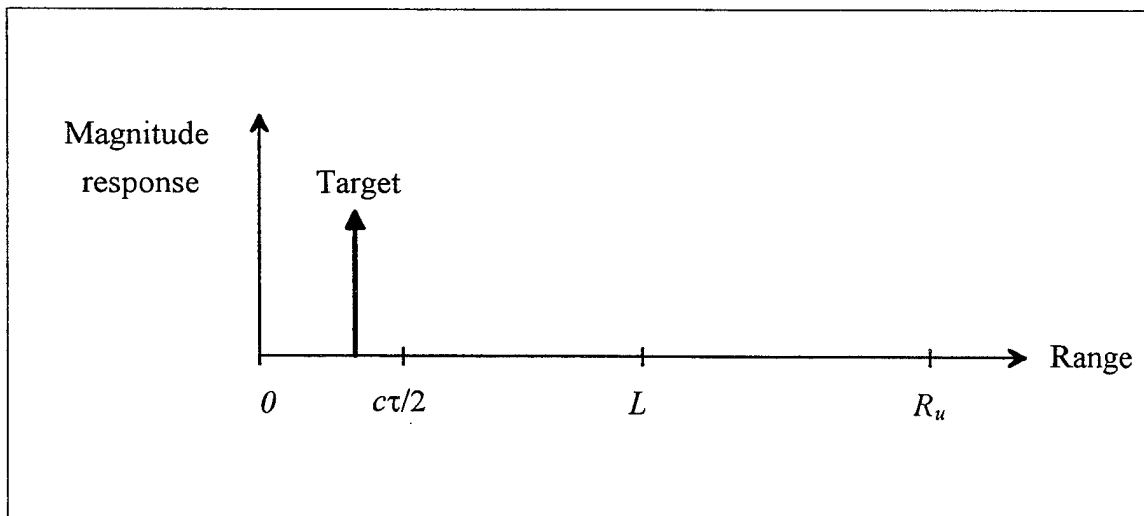

Figure 3.7. Final Synthetic Range Profile with the Step Frequency Radar.

IV. SYSTEM COMPARISON

In this chapter, the comparison of the Step Frequency radar with the conventional Constant Frequency radars is performed. The comparison is focused on the effectiveness of the systems in detecting moving targets in clutter.

A. SYSTEM IMPLEMENTATION

The implementation of the two radar systems is similar (Figures 2.1 and 3.1). Their difference is that the Step Frequency radar system requires a number of stages in addition to the stages which are required for the Constant Frequency radar system. These additional stages are the fast coherent step frequency synthesizer for the generation of the stepped frequency, and a mixer for the up-conversion of the product between the signal of the coherent oscillator and the signal of the step frequency synthesizer in the transmitter, as well as a radio-frequency amplifier for the received echo signal, and a mixer for the down-conversion of the product between the signal of the stable local oscillator and the amplified radio-frequency signal in the receiver.

Both systems detect the Doppler-frequency shift due to the motion of the target and use it to separate moving targets from clutter. The carrier frequency of the transmitted pulses is fixed for the Constant Frequency radar system, but changes linearly with each pulse for the Step Frequency radar system.

The information concerning the Doppler-frequency shift is contained in the outputs of the I - Q phase detectors of the two radar systems. Because of the change in the radar

frequency from pulse to pulse in the Step Frequency radar system, the detection of the Doppler-frequency shift is more complicated than the detection of the Doppler-frequency shift in the conventional Constant Frequency radar system (Equations 2.10 and 3.11).

The two radar systems have the same instantaneous bandwidth for the same pulse width (Equations 2.11 and 3.16). However, due to the nature of the step frequency waveform, the effective bandwidth of the Step Frequency radar system is significantly larger than that of the Constant Frequency radar system, whose effective bandwidth equals its instantaneous bandwidth, (Equations 2.12 and 3.17). The step frequency waveform does not improve the frequency resolution any more than the conventional constant frequency waveform.

Due to the fact that the achieved range resolution is analogous to the inverse of the effective bandwidth, the theoretical high range resolution achieved by the Step Frequency radar system is much better than the typical range resolution achieved by the conventional Constant Frequency radar system (Equations 2.14 and 3.19, Figure 3.4).

The generation of the waveform is a critical aspect for the high range resolution radar systems. In addition, the efficient performance of the Step Frequency radar system highly depends upon the selection of its primary parameters, namely the pulse width and the frequency step size. However, the selection of the primary parameters, in turn, depends upon the maximum target extent (Equations 3.24 and 3.25).

The multiple-time-around clutter (MTAC) is accepted by the Constant Frequency radar system, but it is rejected by the Step Frequency radar system. The signal-to-clutter

(SCR) ratio at the output of the intermediate-frequency filter is large for the Step Frequency radar, as compared to the conventional Constant Frequency radars.

B. SIGNAL PROCESSING

The first stages of the signal processors, before the magnitude detection for the Constant Frequency radar system and the clutter cancellation for the Step Frequency radar system, are the same, but their following portions are very different.

For reporting a target, the signal processor of the Constant Frequency radar system needs basically two more stages, the magnitude detection stage and the constant false alarm rate detection stage, whereas the signal processor of the Step Frequency radar system, in order to provide the final synthetic range profile, needs a clutter cancellation stage, a mixer, a stage for the calculation and employment of the velocity compensation factor, extra weighting, and additional employment of the fast Fourier transform algorithm (Figures 2.6 and 3.5).

Both radar systems require a minimum sampling rate for their analog-to-digital converters which equals the inverse of their pulse width. For the same range resolution, the number of samples which need to be collected and processed is large for the Constant Frequency radar system and small for the Step Frequency radar system.

In general, a pulse of short duration is required for minimization of the clutter. The short pulse, though, results in low average power which, in turn, reduces the target detectability due to low signal-to-noise ratio. For solving this problem, the Constant Frequency radar systems use pulse compression waveforms which provide large average

power, thus ensuring high signal-to-noise ratio, while still maintaining a narrow effective pulse width after the compression for lower clutter. However, the conventional pulse compression requires a wide instantaneous bandwidth receiver and higher analog-to-digital sampling rates since the compressed pulse width is achieved within a single pulse. Thus, hardware and bandwidth requirements increase significantly for the conventional pulse compression for high range resolution with Constant Frequency radar systems. On the other hand, the Step Frequency radar system achieves a high range resolution, with a lower instantaneous receiver bandwidth and lower analog-to-digital sampling rates, because large bandwidth is obtained sequentially with the step frequency waveform by changing the carrier frequency in steps over several pulses instead of within a single pulse. Each individual pulse can be of relatively longer duration resulting in a lower instantaneous bandwidth component which allows the usage of a narrowband receiver as well as a lower analog-to-digital sampling rate.

The step frequency waveform allows for simultaneous pulse compression and Doppler signal processing. The pulse compression ratio equals one for the unmodulated Constant Frequency radar system, while for the Step Frequency radar system it equals the product among the number of pulses, the pulse width, and the frequency step size (Equation 3.23 and Figure 3.4). This means that if the pulse compression is the only reason for using the step frequency waveform, then the time which is needed in order to collect the signals, is longer for the Step Frequency radar system, comparing with the Constant Frequency radar system. If Doppler processing is also required for the

conventional Constant Frequency radar system, then the time to collect the signals is the same for both waveforms.

The required dynamic range of the analog-to-digital converter is large for the Constant Frequency radar system and small for the Step Frequency radar system. For the latter, the dynamic range of the incoming signal which mainly consists of clutter, is reduced by limiting the multiple-time-around clutter. However, this also reduces the coverage in range. This limitation can be removed by using several parallel receiving channels.

Concerning the echo signals from moving targets, the two characteristics of the stepped frequency returns, that is the shifting and the dispersion of the range profile, which are found in Step Frequency radar systems with typical Doppler signal processing, are not found in conventional Constant Frequency radar systems. Since the shift of the target peak for several range bins from its original position, due to range-Doppler coupling, depends upon the velocity of the target, the exact amount of it is not known beforehand. In addition, the dispersion spreads out the target signal into several range bins during the course of integration of the pulse returns, resulting in loss of range resolution and decrease in the magnitude of the signal. The described complications are a disadvantage for the step frequency waveform, which, however, is resolved at the expense of the more complex signal processing. The important points in the above discussion are summarized in Table 4.1.

	Constant Frequency Radar System	Step Frequency Radar System
Instantaneous Bandwidth	<i>Large</i>	<i>Small</i>
Effective Bandwidth	$1/\tau$	$N\Delta f$
Range Resolution	$c\tau/2$	$c/2N\Delta f$
Pulse Compression Ratio	1	$N\tau\Delta f$
Minimum Required Sampling Rate of A/D Converter	<i>Large</i>	<i>Small</i>
Required Dynamic Range of A/D Converter	<i>Large</i>	<i>Small</i>
Number of Samples to be Collected and Processed	<i>Large</i>	<i>Small</i>
Effect of Target Motion	<i>Doppler Shift</i>	<i>Doppler Shift with Target Magnitude Attenuation and Spreading in the Frequency Domain</i>
Multiple-Time-Around Clutter	<i>Accepted</i>	<i>Rejected</i>
Signal-to-Clutter Ratio at the Output of the IF Filter	<i>Small</i>	<i>Large</i>

Table 4.1. Comparison of the Step Frequency Radar with the Conventional Constant Frequency Radars.

C. CONCLUSION

In this thesis, the Step Frequency radar is compared with the conventional Constant Frequency radars. The two radar systems were analyzed in Chapters II and III. The comparison is summarized in Table 4.1. The outcome of this investigation is that, when high range resolution is required, the Step Frequency radar has distinct advantages over the conventional Constant Frequency radars. It was found that, for the same range resolution, the Step Frequency radar has smaller instantaneous receiver bandwidth. Thus, the required sampling rate of its analog-to-digital converter is smaller, and the number of samples which need to be collected and processed is also smaller, as compared to the conventional Constant Frequency radars. The required dynamic range of its analog-to-digital converter is also smaller than for the conventional Constant Frequency radars. The multiple-time-around clutter is rejected by it, whereas it is accepted by the conventional Constant Frequency radars. The Step Frequency radar achieves larger signal-to-clutter ratio at the output of its intermediate-frequency filter, than the conventional Constant Frequency radars. These differences lead to lower bandwidth and hardware requirements for the Step Frequency radar, which, in contrast, are the major limiting factors for achieving high range resolution with the conventional Constant Frequency radars.

Thus, the distinct advantage of the Step Frequency radar, over the conventional Constant Frequency radars, is that it can reduce the clutter footprint without increasing the instantaneous radar bandwidth. However, in the Step Frequency radar the range

coverage is limited and, also, more complex signal processing is required to override the effects of the target motion.

The step frequency waveform can be implemented on existing radar equipment by using a step frequency synthesizer. Thus, the Step Frequency radar provides a good tradeoff as compared to the conventional Constant Frequency radars which, for achieving high range resolution, are often limited by the instantaneous receiver bandwidth and the analog-to-digital converter technology.

LIST OF REFERENCES

1. Wehner, D. R., *High-Resolution Radar*, Second Edition, Artech House, Inc., 1995.
2. Skolnik, M. I., *Radar Handbook*, Second Edition, McGraw-Hill, Inc., 1990.
3. Skolnik, M. I., *Introduction to Radar Systems*, Second Edition, McGraw-Hill, Inc., 1980.
4. Gill, G. S., *Detection of Targets Embedded in Clutter Using Frequency Step Waveform*, Proceedings of the 1994 International Symposium on Noise and Clutter Rejection in Radars and Imaging Sensors, pp. 115-120, Kawasaki, Japan, Nov. 15-17, 1994.
5. Soares, P. A., *Step Frequency Waveform Design and Analysis Using the Ambiguity Function*, Master's Thesis, Naval Postgraduate School, Monterey, California, June, 1996.
6. Ma, Y. B., *Velocity Compensation in Stepped Frequency Radar*, Master's Thesis, Naval Postgraduate School, Monterey, California, December, 1995.

INITIAL DISTRIBUTION LIST

1. Defence Technical Information Center 2
8725 John J. Kingman Rd., STE 0944
Ft. Belvoir, Virginia 22060-6218
2. Dudley Knox Library 2
Naval Postgraduate School
411 Dyer Rd.
Monterey, California 93943-5101
3. Chairman, Code EC 1
Department of Electrical and Computer Engineering
Naval Postgraduate School
Monterey, California 93943-5121
4. Professor Gurnam S. Gill, Code EC/GI 4
Department of Electrical and Computer Engineering
Naval Postgraduate School
Monterey, California 93943-5121
5. Professor Phillip E. Pace, Code EC/Pc..... 1
Department of Electrical and Computer Engineering
Naval Postgraduate School
Monterey, California 93943-5121
6. Hellenic Ministry of Defense 1
Army General Staff
Technical Corps Division
APO 1020
Hellas
7. Major Dimitrios N. Geladakis 1
Hellenic Ministry of Defense
Army General Staff
Technical Corps Division
APO 1020
Hellas