

# SINGLE MODE TWENTY ATMOSPHERE CO<sub>2</sub> LASER

FINAL REPORT

JERALD R. IZATT

JUNE 5, 1997

U. S. ARMY RESEARCH OFFICE

GRANT NO. DAAH04-93-G-0480

UNIVERSITY OF ALABAMA

DTIC QUALITY INSPECTED 4

APPROVED FOR PUBLIC RELEASE;  
DISTRIBUTION UNLIMITED.

The views, opinions, and/or findings contained in this report are those of the author and should not be construed as an official Department of the Army position, policy, or decision, unless so designated by other documentation.

19970819 100

# REPORT DOCUMENTATION PAGE

*Form Approved*  
OMB NO. 0704-0188

Public reporting burden for this collection of information is estimated to average 1 hour per response, including the time for reviewing instructions, searching existing data sources, gathering and maintaining the data needed, and completing and reviewing the collection of information. Send comment regarding this burden estimate or any other aspect of this collection of information, including suggestions for reducing this burden, to Washington Headquarters Services, Directorate for Information Operations and Reports, 1215 Jefferson Davis Highway, Suite 1204, Arlington, VA 22202-4302, and to the Office of Management and Budget, Paperwork Reduction Project (0704-0188), Washington, DC 20503.

1. AGENCY USE ONLY (Leave blank)	2. REPORT DATE 5 Jun 97	3. REPORT TYPE AND DATES COVERED Final Report: 1 Sept 93 - 31 March 97	
4. TITLE AND SUBTITLE Single Mode Twenty Atmosphere CO <sub>2</sub> Laser		5. FUNDING NUMBERS DAAH04-93-G-0480	
6. AUTHOR(S) Jerald R. Izatt		8. PERFORMING ORGANIZATION REPORT NUMBER	
7. PERFORMING ORGANIZATION NAME(S) AND ADDRESS(ES) University of Alabama Box 870324 Tuscaloosa, AL 35487-0324			
9. SPONSORING / MONITORING AGENCY NAME(S) AND ADDRESS(ES) U.S. Army Research Office P.O. Box 12211 Research Triangle Park, NC 27709-2211		10. SPONSORING / MONITORING AGENCY REPORT NUMBER  AR0 32401.1-PH-DPS	
11. SUPPLEMENTARY NOTES The views, opinions and/or findings contained in this report are those of the author(s) and should not be construed as an official Department of the Army position, policy or decision, unless so designated by other documentation.			
12a. DISTRIBUTION / AVAILABILITY STATEMENT  Approved for public release; distribution unlimited.		12 b. DISTRIBUTION CODE	
13. ABSTRACT (Maximum 200 words) A high power, UV preionised, twenty-atmosphere CO <sub>2</sub> laser has been designed and constructed. Its primary line preionised, and tuning configuration comprises a two-grating/retromirror assembly in which both gratings are worked near grazing incidence and double passed. It is used in a three-mirror resonator cavity. In preliminary tests the new laser has produced 130 nsec, 200 mJ pulses with a linewidth less than 200 MHz, which can be tuned continuously in the P and R branches of both the 00 <sup>0</sup> <sub>1</sub> - 10 <sup>0</sup> <sub>0</sub> and 00 <sup>0</sup> <sub>1</sub> - 02 <sup>0</sup> <sub>0</sub> bands. This performance exceeds by a wide margin any results reported in the open literature. Wave-length tuning, pulse initiation, and data acquisition are computer controlled. One planned use of the new laser is to investigate the double Raman effect and other nonlinear processes in far infrared lasers. An international team of scientists participated in the design of the laser. During their stay at Alabama they also conducted, as part of this project, research on four-wave mixing, two-photon absorption and lasing without inversion, all in far-infrared laser gases. Brief reports of these studies are included in this report.			
14. SUBJECT TERMS high power multiatmosphere CO <sub>2</sub> lasers, tunable SLM lasers, double Raman far-infrared lasers, nonlinear effects in gases		15. NUMBER IF PAGES 27	16. PRICE CODE
17. SECURITY CLASSIFICATION OR REPORT UNCLASSIFIED	18. SECURITY CLASSIFICATION OF THIS PAGE UNCLASSIFIED	19. SECURITY CLASSIFICATION OF ABSTRACT UNCLASSIFIED	20. LIMITATION OF ABSTRACT UL

# SINGLE MODE TWENTY ATMOSPHERE CO<sub>2</sub> LASER

FINAL REPORT

JERALD R. IZATT

JUNE 5, 1997

U. S. ARMY RESEARCH OFFICE

GRANT NO. DAAH04-93-G-0480

UNIVERSITY OF ALABAMA

APPROVED FOR PUBLIC RELEASE;  
DISTRIBUTION UNLIMITED.

The views, opinions, and/or findings contained in this report are those of the author and should not be construed as an official Department of the Army position, policy, or decision, unless so designated by other documentation.

## FOREWORD

One aspect of the work reported here is unusual and requires a brief explanation. The primary goal of this project was the construction of a continuously-tunable, single-longitudinal-mode, high-pressure, high-power CO<sub>2</sub> laser. This instrument would represent an advance in the state of the art, and its design and construction were to be accomplished at the University of Alabama by a small team of Russian, German and American scientists who shared long experience with similar lasers and a mutual interest in their application to molecular spectroscopy and the study of nonlinear optical phenomena in gaseous media. The project was conceived originally as a formal collaboration between laboratories in the three countries, but subsequent circumstances have led to dissolution of the Russian laboratory in question and the anticipated formal ties were never realized. In spite of these circumstances, scientists from each of the other laboratories did come to the University of Alabama to participate in this project. They, and their affiliations at the time the project was initiated are as follows: Dr. Wolfgang Schatz, Institut für Angewandte Physik, Universität Regensburg; and Drs. Vladimir B. Fleurov and Andrey O. Radkevich, Institute of Physics and Technology, Russian Academy of Sciences, Moscow. During the later stages of the project Dr. Schatz was affiliated with the Max-Born Institut für Nichtlineare Optik und Kurzzeitspektroskopie, Berlin. The cooperation of their respective laboratories in making these visits possible was essential to the success of the project. In addition, several pieces of equipment were loaned back and forth between the laboratories during the project, and some small but essential components of the SLM laser were fabricated at the Universität Regensburg.

The participation of these guest scientists was not confined to their direct involvement with the new laser. Their access to our equipment and their direct interaction with each other and with University of Alabama researchers and technicians also made it possible for them to carry out other

closely related projects. As a result research on four wave mixing, two photon absorption, and lasing without inversion was completed and published and/or presented at international conferences. Abstracts of these papers are included in section IV of this report. This research constitutes an integral part of the project reported here.

Having been stimulated by ARO support of this project, the participants plan to continue this collaboration as circumstances permit, not only to effect the minor changes in laser design described in this report, but also to use the laser for a variety of research problems.

## TABLE OF CONTENTS

	page
List of tables and figures	1
I. Objectives and results	2
I.A. Background	2
I.B. Specific goals	3
I.C. Summary of results	3
I.D. Assessment of results and description of work currently in progress	9
II. Detailed description of SLM laser	13
II.A Twenty-atmosphere gain section and power supply	13
II.B. Line-narrowing and tuning modules	17
III. References	21
IV. Publications	22
V. Scientific personnel	24

LIST OF TABLES AND FIGURES

	page
Table 1. Summary of laser characteristics.	5
Fig. 1. Grating configurations for performance measurements.	6
Fig. 2. Wavelength tuning scans with configuration A.	7
Fig. 3. Voltage applied to Marx bank for diverse operating conditions.	8
Fig. 4. Sample wedged-etalon fringes for linewidth measurements using configuration B.	8
Fig. 5. 10R branch wavelength scan with configuration D.	9
Fig. 6. Third mirror interference fringes.	11
Fig. 7. Measured grating efficiency curves.	12
Fig. 8. Laser gain section, gas-handling system and high voltage power supply.	14
Fig. 9. Diagram of preionization electrodes on one side of the discharge volume.	15
Fig. 10. Parallel electrical connection scheme for UV preionization spark gaps.	15
Fig. 11. Marx bank schematic.	16
Fig. 12. Two-grating configurations.	19
Fig. 13. Angular dispersion produced by grating configurations a, b, and c.	19
Fig. 14. Mechanical layout of two-grating tuning module.	20

## I. OBJECTIVES AND RESULTS

### I.A. Background

The revolutionary impact of the CO<sub>2</sub> laser on conventional high resolution molecular spectroscopy is well known, as is its perhaps even more dramatic effect on the study of nonlinear and multiphoton effects in gases. Great progress in these areas has been realized even though the spectrum of conventional CO<sub>2</sub> lasers, while spanning an interesting region of the infrared, is almost completely empty. The emission lines of a typical cw laser occupy less than 1% of the full spectrum spanned by the 00<sup>0</sup>1 → 10<sup>0</sup>0 and 00<sup>0</sup>1 → 02<sup>0</sup>0 bands. Production of tunable narrow-linewidth laser emission throughout the interline gaps would provide significant additional advantages in many applications including pollution monitoring [1], double resonance molecular spectroscopy [2], and optical pumping of far infrared (FIR) lasers [3-5]. We are particularly interested in the latter application, both as a source of continuously-tunable, narrow-linewidth FIR radiation and for the production of ultrashort FIR laser pulses[6]. The participants in this project are responsible for much of the progress, both theoretical and experimental, that has been realized on FIR double Raman lasing and other nonlinear processes in CH<sub>3</sub>F and other methyl halides.

Optically pumped FIR lasers are themselves useful for a wide variety of fundamental scientific studies and practical applications. In terms of their spectral characteristics these lasers range from narrow-linewidth frequency-stabilized cw lasers, operating at thousands of discrete wavelengths, to pulsed double-Raman lasers which presently have broad linewidths but can be tuned continuously over FIR bands hundreds of microns in width. In some cases both narrow linewidth and continuous tunability are required. One approach is to try to achieve transform-limited linewidth in a pulsed double-Raman laser by pumping it with a tunable multi-atmosphere laser that oscillates on a single longitudinal mode at each wavelength setting. At present CH<sub>3</sub>F double Raman FIR lasers can be tuned throughout most of the 150 - 650 μm region. However, to date they have only been pumped with broadband CO<sub>2</sub> lasers oscillating on dozens of longitudinal modes, and neither their potential spectral purity nor their potential efficiency has been reached. Under the pumping conditions we seek to achieve, many interesting nonlinear molecular effects in addition to the

double Raman process can also be studied. They include the following phenomena, which we have already studied experimentally at lower resolution and/or for which we are in the process of developing theoretical models: four-wave mixing [7], two-photon absorption [8], and lasing without inversion [9].

### I.B. Specific Goals

Conventionally, broad tunability of a multi-atmosphere CO<sub>2</sub> laser is achieved by using an intracavity grating, and the resulting linewidth is in the 3 to 9 GHz range. In applications where greater spectral purity is required intracavity etalons or injection techniques have been used to achieve oscillation on a single longitudinal mode with a resulting linewidth of the order of 100 MHz or less, but the tuning range is then restricted to, at most, a few gigahertz. The goal of the work reported here is to produce SLM pulses of approximately 100 MHz linewidth which can be tuned in mode-to-mode steps (~100 MHz) between all of the strongest lines in the 00<sup>0</sup>1 → 10<sup>0</sup>0 and 00<sup>0</sup>1 → 02<sup>0</sup>0 gain bands by using a pair of grazing-incidence intracavity gratings. For some special applications in which SLM operation without broad tunability suffices, a temperature controlled intracavity etalon is also to be provided. Other important goals of the present work are to minimize arc formation in the high voltage laser discharge and reduce rf contamination of the neighborhood in which the laser operates.

### I.C. Summary of results

We have designed, constructed and carried out preliminary testing of a single-stage 20-atmosphere laser. The discharge section, which is optimized for SLM operation employs uv preionisation, uniform-field electrodes, and sealed-off operation. High voltage is provided by a two-stage Marx bank. The two-grating tuning section comprises the following components: 1) a 2.5 cm x 10 cm, 150 l/mm grating blazed at 56°, 2) a 2.5 cm x 25 cm, 150 l/mm grating blazed at 52°, 3) a 2 cm x 25 cm plane retromirror, 4) a stepping-motor-driven rotary table for the retromirror, and 5) computer controls for wavelength scanning, laser pulse initiation, and various data collection functions. Both diffraction gratings are worked near grazing incidence and double passed. More detailed descriptions are given in section II.

The laser performance achieved to date is summarized in Table 1, where it is also compared to the performance of three other high pressure lasers that have been described in the literature. The lasers chosen for comparison include devices that played an important role in the evolution of the current design and also the most recently published results, an 11-atmosphere laser reported in September 1996 [1]. For the tests of the new laser that are summarized in Table 1, four different grating configurations were used. They are labeled A - D. These configurations are shown schematically in Fig. 1. In each case the other end of the resonant cavity was closed by a Ge output coupler  $M_2$  with a radius of curvature of 10 m, which was coated for 60% reflectivity on the curved surface and anti-reflection coated on the flat surface.

Initial optical alignment of the laser was carried out in a series of steps corresponding to successively higher spectral resolutions, which were designed to test the adequacy of the electrical, optical and mechanical elements of the system. Configuration C was the culmination of this process. Along the way the measurements that are described below were carried out.

Initially, the tuning range in each of the four CO<sub>2</sub> laser bands was measured using configuration A. Typical scans are shown in Fig. 2. Here the output pulse energy was held to a maximum of 200 mJ to avoid damage to the grating. This required that the voltage supplied to the Marx bank be limited to 56 kV during the R-branch scans. Voltages corresponding to several other operating conditions are shown in Fig. 3 and compared to the overall laser operating range of 50 - 70 kV. No linewidth measurements were made for configuration A, but we know from previous experience that it must have been greater than 3.5 GHz.

Next, linewidth measurements were made with the three-mirror cavity labeled configuration B. The third mirror (interposed between the gain section and the grating) was an 8-mm thick ZnSe window, uncoated on both surfaces, so that its reflectivity was  $\sim 17\%$  at each surface. The incidence angle on the grating was varied from  $82^\circ$  to  $86^\circ$ . At each angle, a wedged etalon and an 128-element pyroelectric detector array were used to form and record interference fringes from which the linewidth measurements were made [12]. Some typical fringe patterns are shown in Fig. 4. At an incidence

Table 1. Summary of laser characteristics.

	Mathieu & Izatt [3]	Danly et al [10]	Werling et al [11]	Repond & Sigrist [1]	Present Work
Gas Pressure (atm)	10	10	20	11	20
Gas Mix (CO <sub>2</sub> :N <sub>2</sub> :He)	10:10:80	10:10:80	3:1:60	5:5:90	2:1:60
Flow Rate (l · min <sup>-1</sup> )	1-2	10-15	sealed off	1.7	sealed off
Active Volume (cm <sup>3</sup> )	0.8x0.8x27	0.7x0.64x35	1x1x80	.75x2x 32	1x1x40
Power Supply	2-stage Marx bank 3nF/stage 70kV	5-stage Marx bank; ~16nF/stage 20 kV	2-stage Marx bank 10nF/stage 60kV	2-stage LC inversion 56-70kV	2-stage Marx bank 10 nF/stage 70 kV
Electrodes	Chang	Rogowski	Chang	modified Ernst	Chang
Injected Energy (J · l <sup>-1</sup> · atm <sup>-1</sup> )	100	100	22	27	30
Pulse Length (nsec)	50	100	130	150	100
Repetition Rate (Hz)	0.5	0.3 - 2.0	0.5	0.2	0.5
Output Coupler	Ge R=0.50	Ge R=0.65	Ge R=0.70	zeroth order grating	Ge R=0.60
Grating Configuration	Littrow	Littrow	Littrow	grating at 77° plus retro mirror	A B C D
Linewidth (GHz)	3.6	4	4.8	0.54	~4 0.20 0.16 0.42
Tuning Range	9R10 - 32 9P10 - 32 10R8 - 32 10P8 - 32	unspecified range in 9R & 10R branches - no P tuning	9R6 - 28 9P8 - 28 10R6 - 30 10P10 -26	9R10 - 26 9P12 - 22 10R10-24 10P12-22	10R10-22
Pulse Energy @ 10R16 (mJ)	150	120	300	70	100 100 60

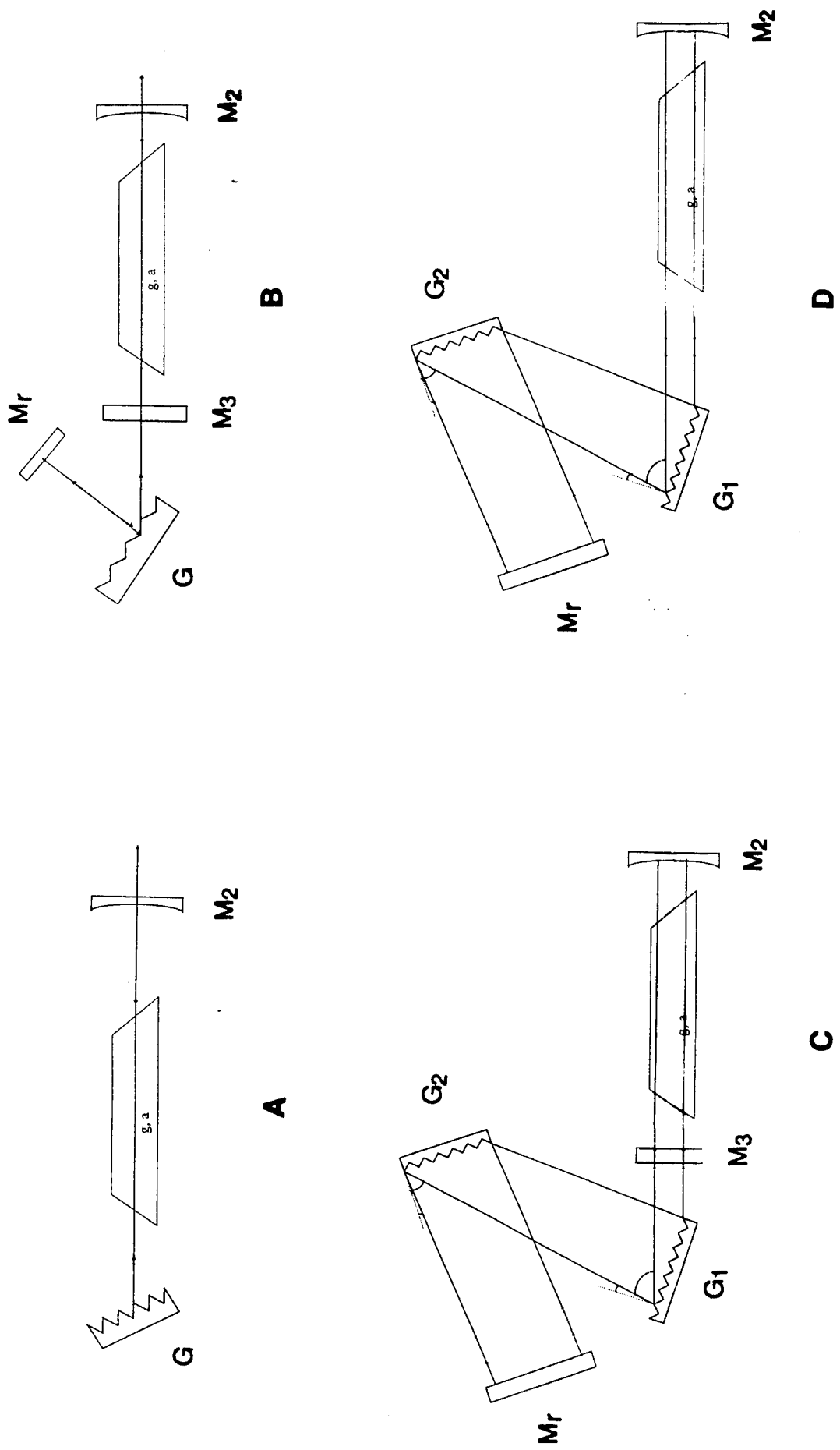

Fig. 1. Grating configurations for performance measurements. A- 150 l/mm Littrow grating; B- near-grazing-incidence, 2cm x 10 cm, 150 l/mm grating G, with a retro-mirror Mr and an uncoated ZnSe 3rd mirror M3; C- near-grazing-incidence, 150 l/mm gratings at G1 (2cm x 10 cm) and G2 (2cm x 25 cm), with a retro-mirror Mr and an uncoated ZnSe 3rd mirror M3; D- same as C but 3rd mirror removed.

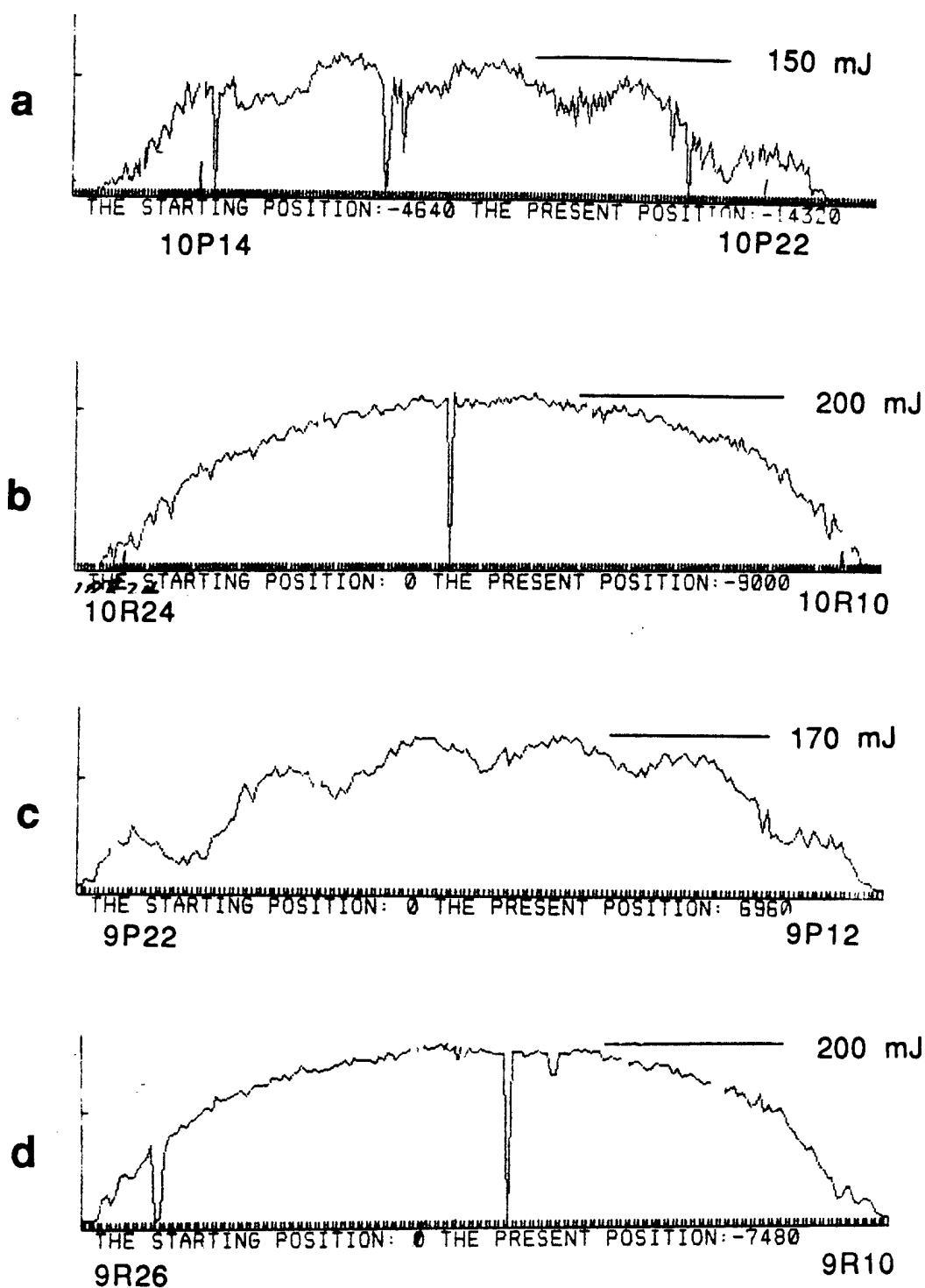

Fig. 2. Wavelength scans with configuration A (single Littrow-mounted grating). a) 10P branch; b) 10Rbranch; c) 9p branch; d) 9R branch.

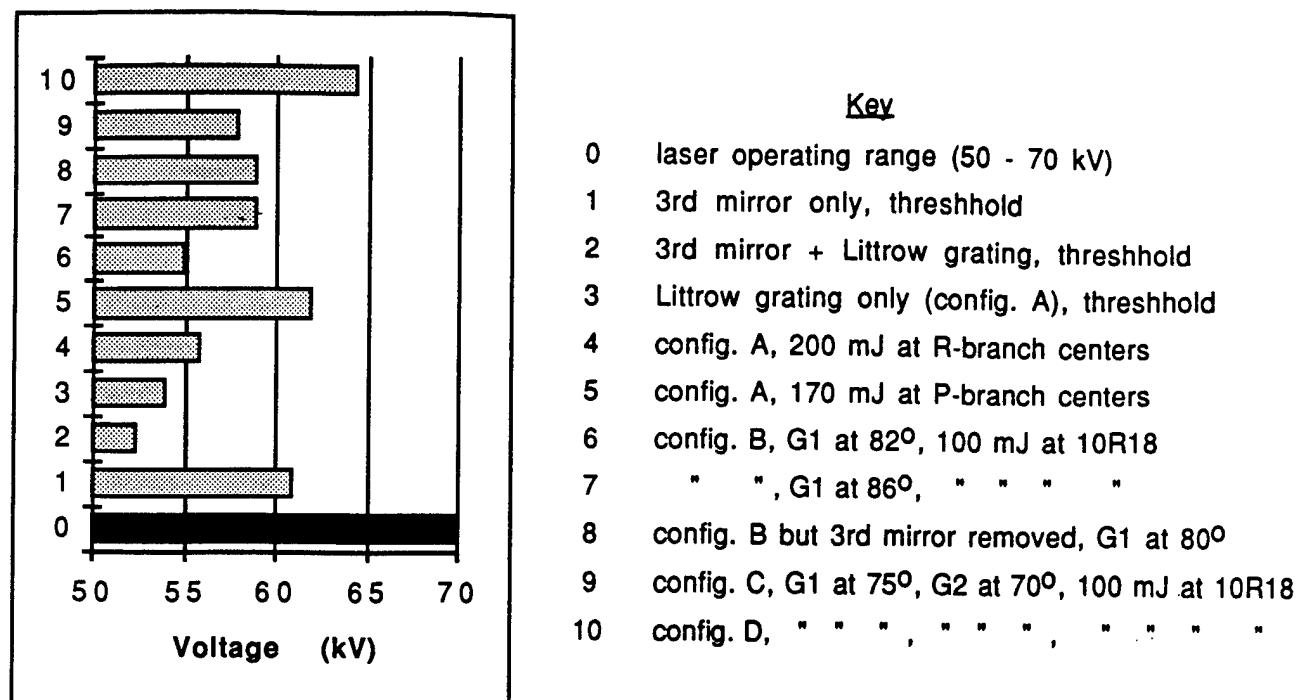

Fig. 3. Voltage applied to Marx bank for diverse operating conditions.

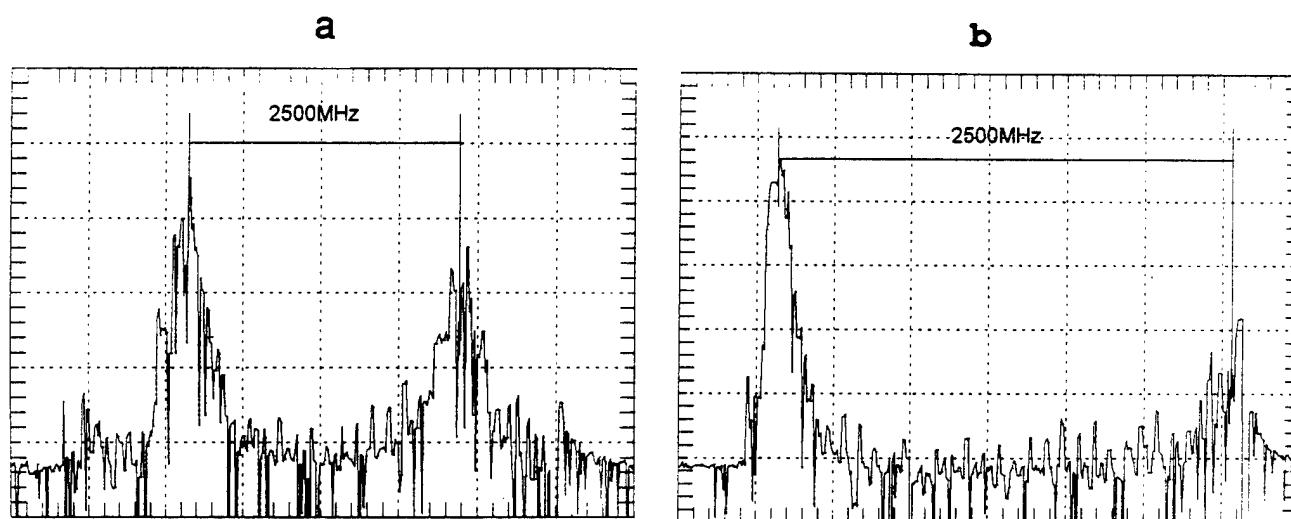

Fig. 4. Sample wedged-etalon fringes for linewidth measurements using configuration B. a) incidence angle of 82°; b) 86°.

angle of  $86^\circ$  the linewidth was  $\sim 200$  Mhz, as indicated in Table 1. No wavelength scanning was done with this configuration.

With configuration C, the wedged etalon and pyroelectric detector array were again used to measure the linewidth. 100-mJ pulses were obtained near 10R18 at a voltage of 58 kV. With  $G_1$  set at an incidence angle of  $75^\circ$  and  $G_2$  at  $70^\circ$ , the linewidth was  $\sim 160$  MHz. This is smaller by a factor of 4 than any result heretofore published. A wavelength scan of the 10R branch was attempted, but it proved to be impractical due to the formation of interference fringes between the faces of the ZnSe 3<sup>rd</sup> mirror. With a linewidth of only 160 MHz the fringes were very sharp and deeply modulated, and this resulted in spectrally periodic gaps in the laser output.

To circumvent this difficulty the 3<sup>rd</sup> mirror was removed from the resonant cavity, resulting in configuration D. It was then necessary to increase the operating voltage to 64.5 kV in order to obtain 100 mJ pulses at 10R18. Linewidth measurements yielded  $\sim 420$  MHz. A 10R-branch wavelength scan, shown in Fig. 5, produced results very similar to those obtained with configuration A; i.e., with a simple Littrow grating.

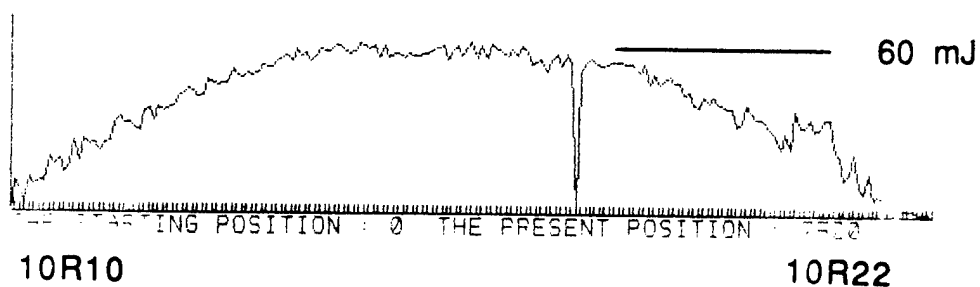

Fig. 5. 10R branch wavelength scan with configuration D.

#### I.D. Assessment of results and description of work currently in progress

We have operated the new laser for an estimated total of  $\sim 60$  hours or  $\sim 10^5$  pulses. The laser discharge has been consistent and quiet. The number of arcs resulting in pulse dropouts can be estimated from Figs. 2 and 5. The wavelength scans shown there comprise, collectively, 1050 laser pulses and there are a total of 9 arcs, yielding an average arc rate less than 1%. This constitutes a major improvement over earlier multiatmosphere lasers that

we have operated. Measurement and control problems arising from rf noise have also occurred much less frequently than during our previous experience. We have had one system breakdown, which resulted from a short in one of the high voltage cables connecting the Marx bank to the discharge section.

Perusal of Fig. 3 indicates that the discharge section would impose no limit for operation well above the 200 mJ/pulse level with any of the three-mirror test configurations. It is rather optical damage to the dispersing elements, and particularly to  $G_1$  in the two-grating configurations, that sets the pulse energy limit.

The tuning range observed with two-grating configuration D is comparable to that obtained with a simple Littrow grating even though the linewidth has been reduced by an order of magnitude. Operating the two-grating system with a third mirror; i.e., in configuration C rather than D, reduces the cavity losses. Some improvement in tuning range can therefore be expected to accompany the further linewidth reduction this configuration provides, once the third-mirror fringes are eliminated. To this end the following steps are in progress. We have recently ordered a 2-mm thick ZnSe partial reflector with stock coatings for the 10.6  $\mu\text{m}$  region. It has a 50% reflection coating on one face and a 0.1 % anti-reflection coating on the other face. A theoretical fringe pattern calculated for this partial reflector is shown in Fig. 6, where it is compared with the theoretical fringe pattern produced by the third mirror used in configuration C. Also shown is a wavelength scan made with the original 3<sup>rd</sup> mirror used with a simple Littrow grating. It appears that the improvement will be adequate for tuning in the 10R and 10 P branches, but purchase of a similar ZnSe partial reflector with special order coatings designed for the region of the 9R and 9P branches would be prohibitively expensive at present. We are therefore investigating the possible use of a coated polypropylene pellicle as a third mirror.

During these tests the round-trip cavity length was 340 cm, which corresponds to a longitudinal mode spacing of 88 MHz. To test whether the ~160 MHz linewidth produced by configuration C was adequate for single-mode operation we used a photon drag detector to observe the temporal profile of the pulses. They display a modulation of a few percent, corresponding to a small admixture of a second mode. In principle, the cavity can be shortened enough to bring the mode spacing to 100MHz. Also, further line narrowing can be achieved with configuration C by increasing

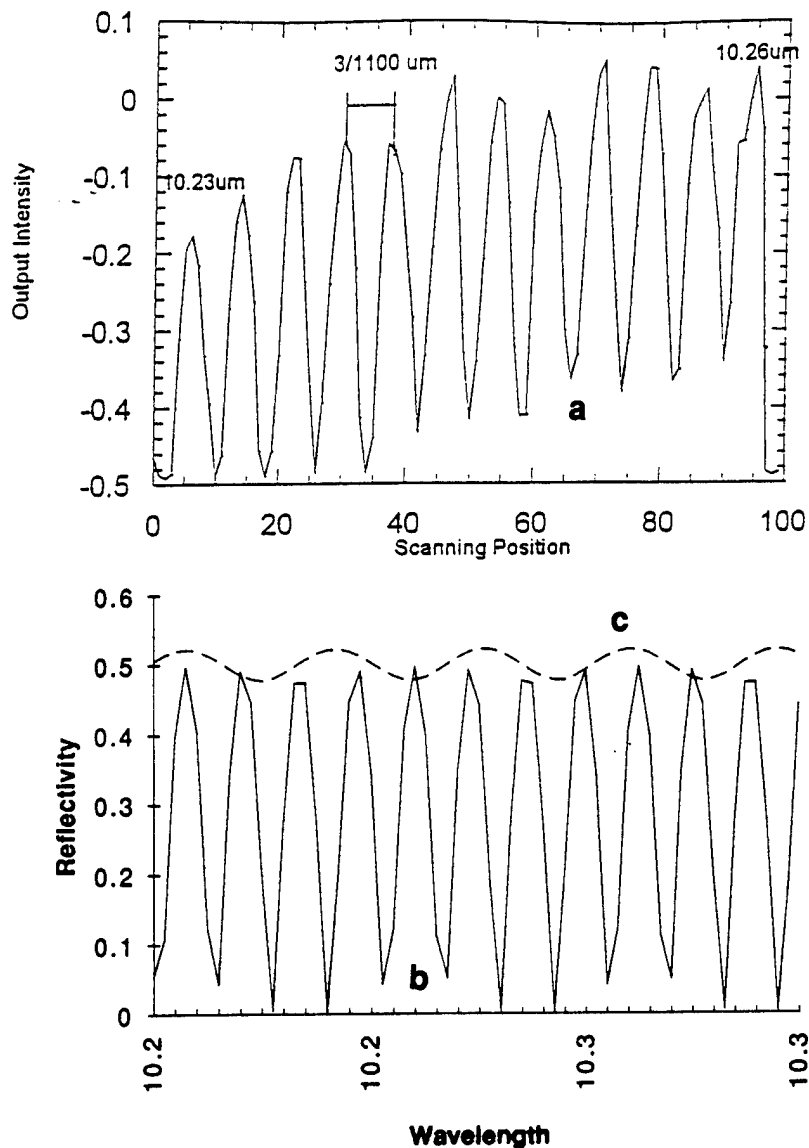

Fig. 6. Third-mirror interference fringes. a) measured in laser output; b) calculated for uncoated ZnSe third mirror used in measurement of a ; c) calculated for ZnSe third mirror with a 50% reflective coating on one face and antireflection coated to 0.1% on the other.

the angle of incidence on  $G_1$  and/or  $G_2$ . As this is done the grating efficiency decreases and at, some point, the beam exceeds the width of the grating and still more energy is lost. (See Ref. 15.) We will continue to explore this tradeoff and also experiment with the cavity length. As we do so we will undertake quantitative correlation of the temporal and frequency structure of the pulses.

The very large gratings required for the two-grating configuration were fabricated in China at a considerable savings in cost. Doing so made it possible to expand the role of the foreign scientists who participated in the project. Before commissioning the ruling of these gratings we had small sample gratings ruled, and we examined their quality both optically and with electron microscopy. The test gratings compared favorably with standard 150 l/mm gratings ruled in the US. There were, however, considerable delays in the final delivery of the large gratings, due largely to communications and money transfer problems rather than technical considerations, and when they were delivered their performance was substandard in two ways. As illustrated in Fig. 7, their overall efficiency was very low. They also had much lower damage thresholds than standard gratings ruled in this country. Early in the testing the 10 cm grating used as G<sub>1</sub> began to exhibit visible damage and drastically reduced performance, and it became necessary to replace it with a domestic 10 cm grating that we had on hand. Although the latter grating also had significant visible surface damage when we installed it, it did not deteriorate further during the tests, and its performance remained adequate. Thus, while we believe that we can achieve fully tunable SLM operation with the present setup, once the third mirror problem is solved, grating damage considerations limit the pulse energy to ~100 mJ. Full realization of the potential of this instrument, both in terms of resolution and pulse energy, would require replacement of the two large gratings.

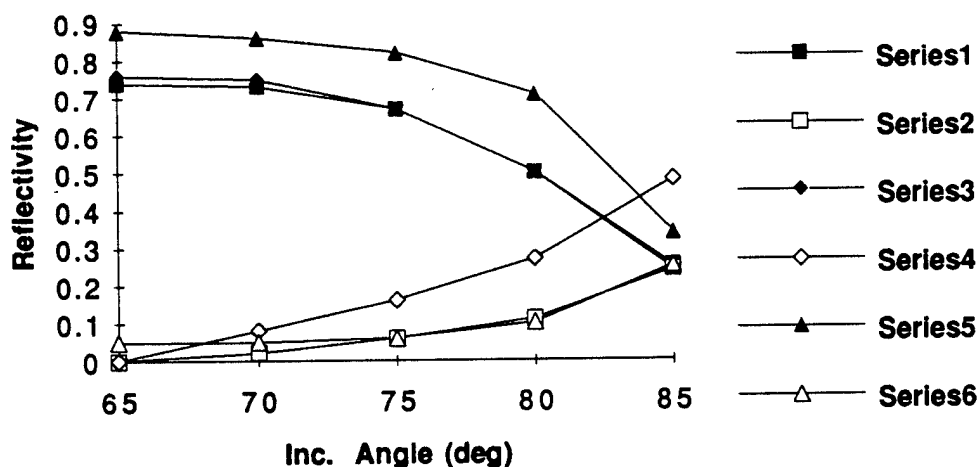

Fig. 7. Measured grating efficiency curves. 10-cm Chinese grating: 1<sup>st</sup> order Series 1, 0<sup>th</sup> order S2. 25-cm Chinese grating: 1<sup>st</sup> order S3, 0<sup>th</sup> order S4. 10-cm domestic grating: 1<sup>st</sup> order S5, 0<sup>th</sup> order S6.

## II. DETAILED DESCRIPTION OF LASER DESIGN

### II.A. Twenty-atmosphere gain section

A schematic diagram of the laser gain section, the gas handling system and the high-voltage power supply is shown in Fig. 8. To maximize the longitudinal mode spacing and thus facilitate single mode selection the shortest gain section consistent with our pulse energy and reliability requirements was employed. We adopted and modified a well-tested, compact design which had previously evolved through three generations of refinement at the Universität Regensburg, culminating in the construction of a 1-J, three-stage, 20-atmosphere laser by Schatz [13]. The active volume of our single-stage discharge section measures 1 cm x 1 cm x 40 cm. It is housed in a massive stainless steel drum, 40 cm in diameter and ~70 cm in length, which is filled to 20 atmospheres with a CO<sub>2</sub>: N<sub>2</sub>: He mixture of 2:1:60. The optical ports are sealed with Brewster angle ZnSe windows, 10.8 mm thick and 50.8 mm in diameter. The gas-filled discharge head is sealed off and can be operated for several hundred hours. When necessary, the gas charge can be circulated through a ceramic platinum catalyst by a high pressure circulating pump to remove the CO and O<sub>2</sub> produced by the high voltage discharge.

A portion of the electrode assembly is shown schematically in Fig. 9. The main discharge electrodes are made of aluminum and have a Chang profile. UV preionisation is provided by a chain of tungsten-needle spark gaps on each side of the discharge volume. Seventeen pairs of tungsten needles are spaced along one side of the Chang electrodes as shown, and 16 pairs are positioned along the opposite side. The latter are displaced longitudinally by half a gap spacing from those shown in order to enhance the uniformity of UV penetration into the discharge volume. The UV spark gaps are connected in parallel and coupled by capacitors to the main discharge electrodes. See Fig. 10. The main purpose of the capacitors is to prevent shorting of the stored high voltage energy through the spark gaps. Each spark gap circuit contains 4 ceramic capacitors rated at 40 kV and connected in series. Main discharge voltages up to 160 kV (i.e., 80 kV into the Marx bank) can therefore be accommodated. However, experience has shown that the failure rate increases significantly when voltages in excess of 140 kV are used. Note that adjacent needles belonging to different spark gaps are at the

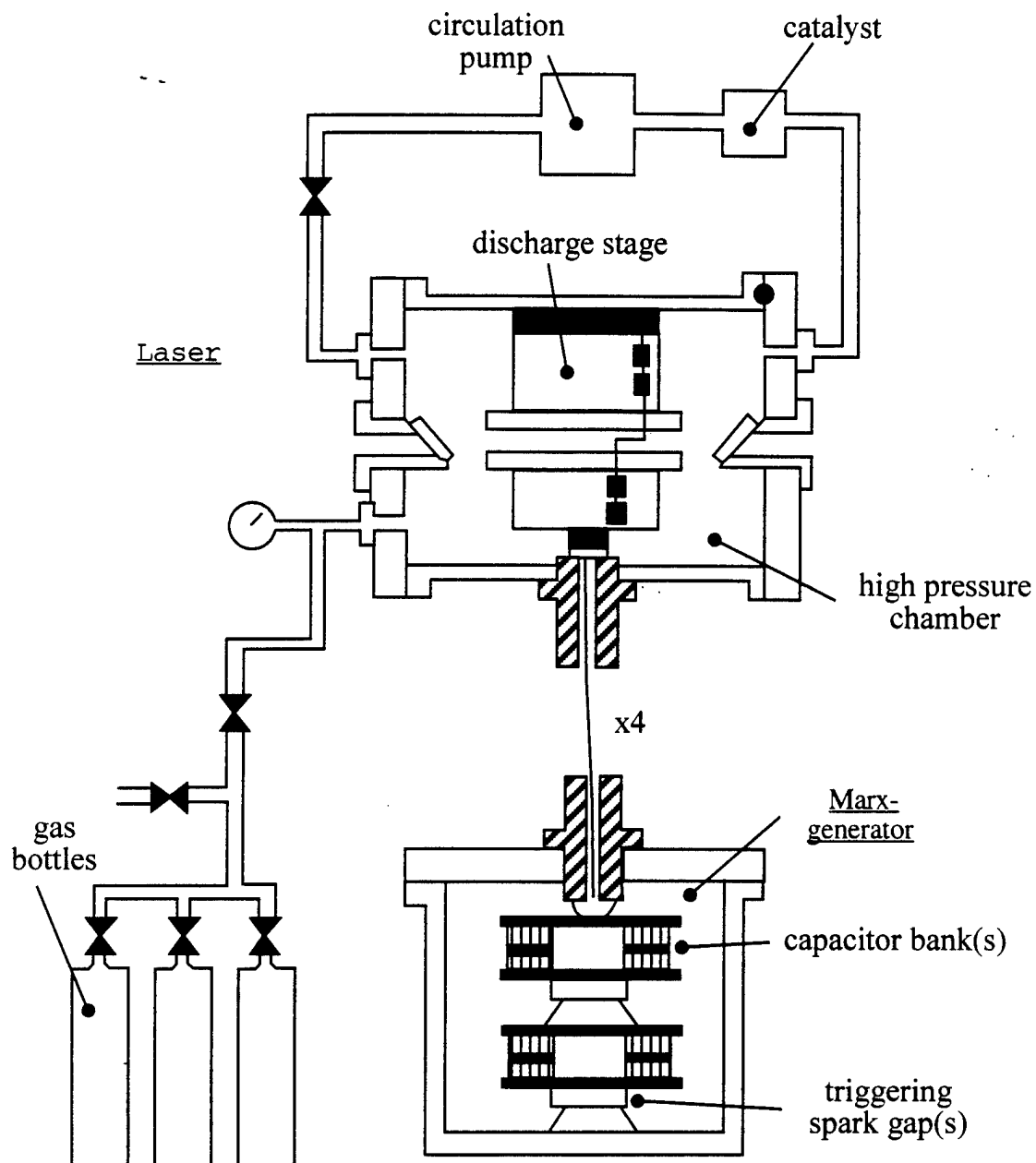

Fig. 8. Laser gain section, gas handling system and high voltage power supply.

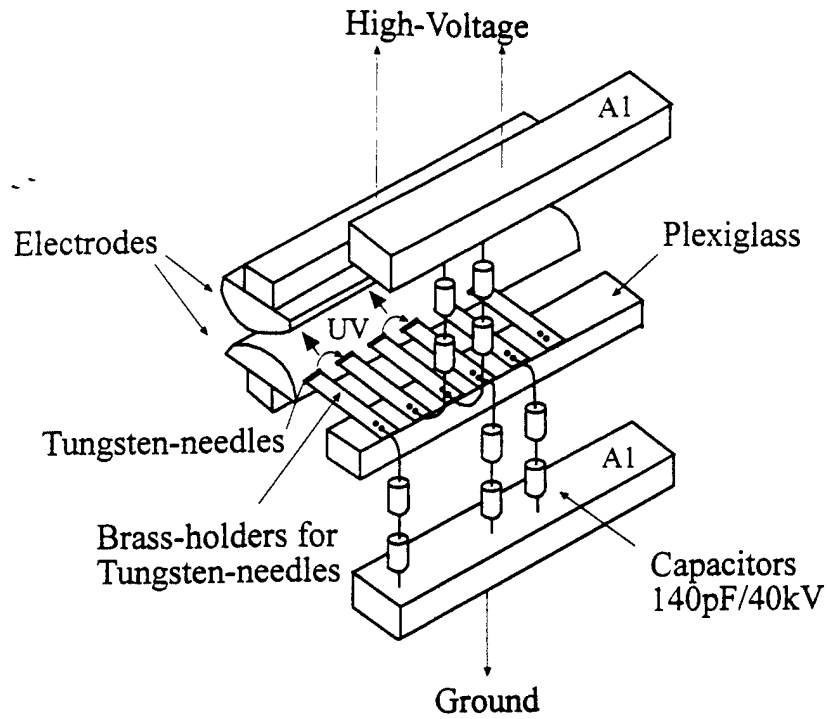

Fig. 9. Diagram of preionization electrodes on one side of the discharge volume.

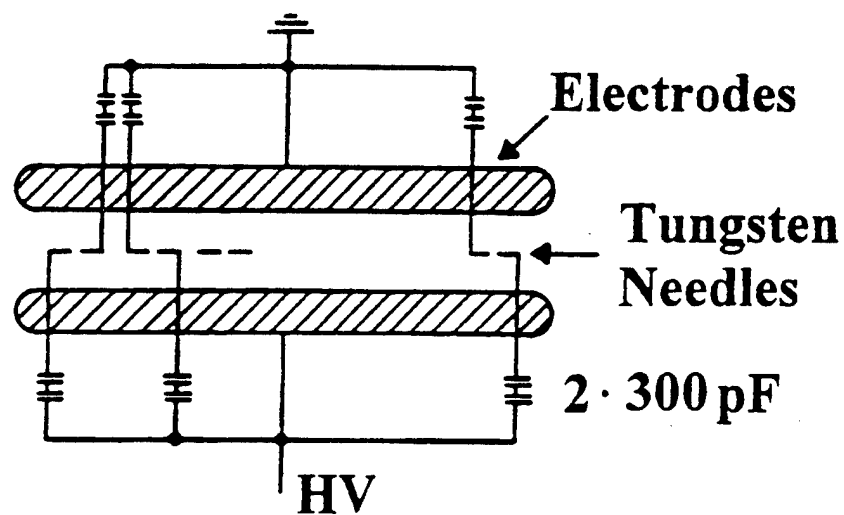

Fig. 10. Parallel electrical connection scheme for UV preionization spark gaps.

same potential so that breakdown between successive gaps is avoided. Parallel connection of the spark gaps has two principal advantages over the more usual series connection: 1) the inductance of the spark gap circuits is reduced, leading to shorter and stronger current pulses and hence to more intense UV pulses; 2) the resulting preionisation occurs almost simultaneously throughout the discharge volume.

With this configuration only one high voltage power supply is required. High voltage for both the preionization and main discharges is provided by a two-stage Marx generator, for which a circuit diagram is shown in Fig. 11. It is mounted in a separate stainless steel vessel 50 cm in diameter and 65 cm long, which is filled with 5-7 atmospheres of  $N_2$  for electrical insulation.  $N_2$  pressure in the Marx-bank spark gaps can be controlled separately, and it is adjusted empirically in the 60-80 psi range during laser operation to maintain consistent firing. Firing pulses are provided by a trigger generator. They can be initiated automatically at a preselected constant rate or by computer control at a rate determined by the motion of the wavelength tuning optics. In order to maintain a uniform voltage distribution along the electrodes the Marx bank is coupled to the discharge section by four low-inductance coaxial cables, connected in parallel. The discharge section is mounted on an optical table and surrounded by an Invar cage that supports the resonator optics. The Marx bank is located on the floor beside the table. A small crane is provided to facilitate handling of the large pressure vessels when power supply or discharge section components require servicing.

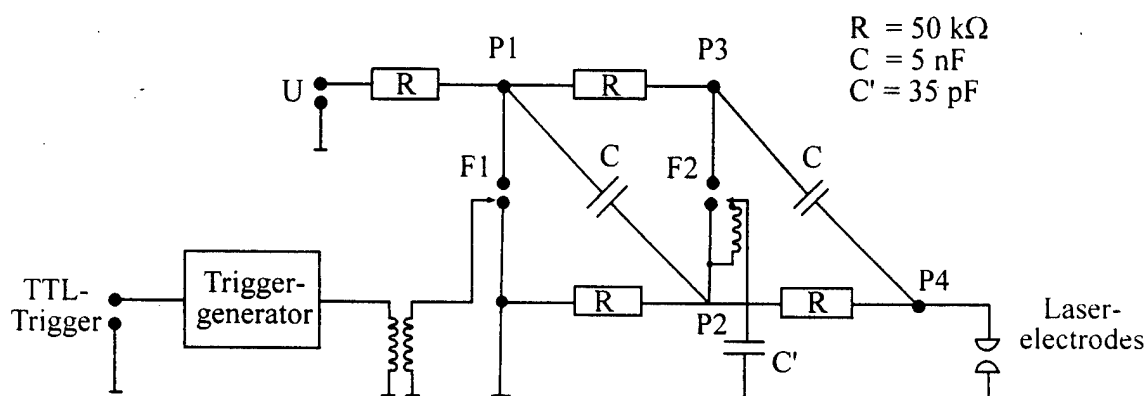

Fig. 11. Marx bank schematic.

This laser has provided satisfactory operation over a convenient range of operating parameters for periods up to eight weeks on a single gas charge. During this period the pressure in the gain section typically drops from an initial 288 psi to ~ 260 psi. Marx-bank charging voltages ranging from 50-70 kV are used, and at a Marx-bank pressure of 90 psi consistent firing is observed with spark gap pressures ranging from 55 to 80 psi. To date, arcs have been observed on less than 1% of the laser shots.

## II.B. Line-narrowing and tuning modules

SLM tuning imposes a stringent tradeoff between resonator length, overall tuning range, and pulse energy. Optimization of this tradeoff depends critically on appropriately designed tuning optics. Many techniques for achieving narrow linewidth and/or broad tunability in both TEA CO<sub>2</sub> and multi-atmosphere lasers have been described in the literature. They include devices which produce SLM operation but whose tunability is restricted to the immediate vicinity of one or more spectral line centers; eg., injection lasers, hybrid lasers, intracavity absorption cells, placing the gain section in one arm of a Michelson interferometer, etc. Other techniques, including several different intracavity Fabry-Perot etalon configurations, can produce SLM operation combined with simple tunability over a somewhat larger range; eg., the free spectral range of the etalon. However, still broader tunability is difficult or impossible to achieve in these devices. Finally, different combinations of diffraction gratings with intracavity beam expanders and/or three-mirror cavities have yielded simple broad-range tunability combined with relatively narrow linewidths. After reviewing the literature and having experimented ourselves with several of these techniques, we had, before the present project began, chosen five of them for a detailed study of their suitability for producing tunable SLM pulses with a multi-atmosphere laser [14]. They were evaluated with respect to five fundamental criteria: 1) reproducibility of SLM pulse generation, 2) total pulse energy, 3) pulse-to-pulse energy variation, 4) optics damage risk, and 5) tuning range and ease. A two-grating cavity produced the best fit to all of these criteria, taken together, while an intracavity Fabry-Perot etalon was judged best in circumstances where criterion 5 could be relaxed. In both cases optimum performance called for use in a three-mirror cavity.

An etalon module constructed for the comparative study cited above has been made available for use with the new SLM laser. Any one of several Ge and ZnSe etalons can be mounted in a water cooled housing and the etalon temperature controlled to within  $\pm 0.01^{\circ}\text{C}$ . The corresponding frequency jitter due to the combination of etalon expansion and the thermal variation of its index of refraction is  $\leq 10$  MHz. The tuning range is restricted to the free spectral range of the etalon and can be accomplished with a temperature change of a few degrees. The free spectral range of the etalons that are available range from 2.54 GHz to 4.9 GHz with corresponding values of finesse between 2.95 and 16.8 (i.e.; theoretical linewidths between 860 MHz and 290 MHz). This tuning module has not yet been used with the new high-pressure laser.

Because of their potential for narrow line selection combined with very broad and relatively easy tunability we focused most of our attention on two-grating tuning modules. Prior to the beginning of the present project we had carried out a theoretical study of various possible two-grating configurations, and pertinent predictions of the theory had been tested experimentally [15]. The two-grating configurations we considered are shown in Fig. 12. This study demonstrated that configuration b provides the highest angular dispersion and consequently the best line narrowing capability. See Fig. 13. Also the tuning curve (wavelength vs. rotation angle) for b has a smaller slope than that for a simple Littrow mounted grating, thus reducing the mechanical control requirements for mode-to-mode tuning. Another practical consideration is the extent of beam expansion and lateral beam motion along the gratings as a wavelength scan proceeds. These effects must be taken into account for all three configurations and do not impose significantly more difficult requirements on the implementation of b than either of the other configurations. For more details see Ref. 15.

These considerations led to the design and construction of the tuning module shown schematically in Fig. 14. The gratings, G<sub>1</sub> and G<sub>2</sub>, are mounted on precision rotation tables so that the angle of incidence on each can be varied independently. When the laser is in operation G<sub>1</sub> and G<sub>2</sub> are fixed in position, and wavelength scanning is accomplished by rotating the retro-mirror M. The fixed angular positions of G<sub>1</sub> and G<sub>2</sub> determine the dispersion of the system, as illustrated in Fig. 13. The optimum tradeoff

between angular dispersion and beam spillover at each of the optical elements is determined empirically.

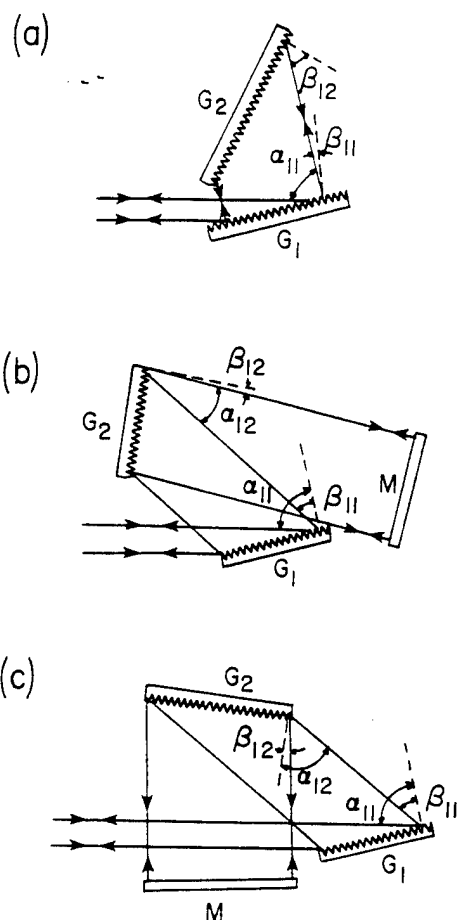
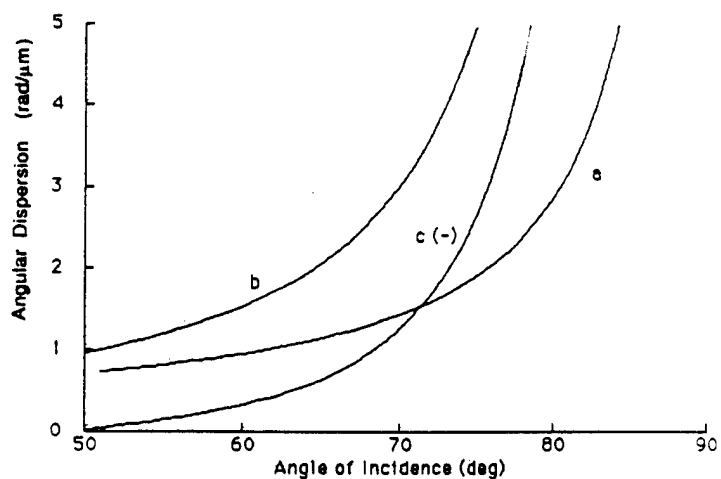

Fig. 12. Two-grating configurations.

Fig. 13. Angular dispersion produced by grating configurations a, b, and c in Fig. 12 as a function of the incidence angle, which is taken to be the same for both  $G_1$  and  $G_2$ . The grating spacing is  $6.67 \mu\text{m}$ , and  $\lambda=10\mu\text{m}$ .



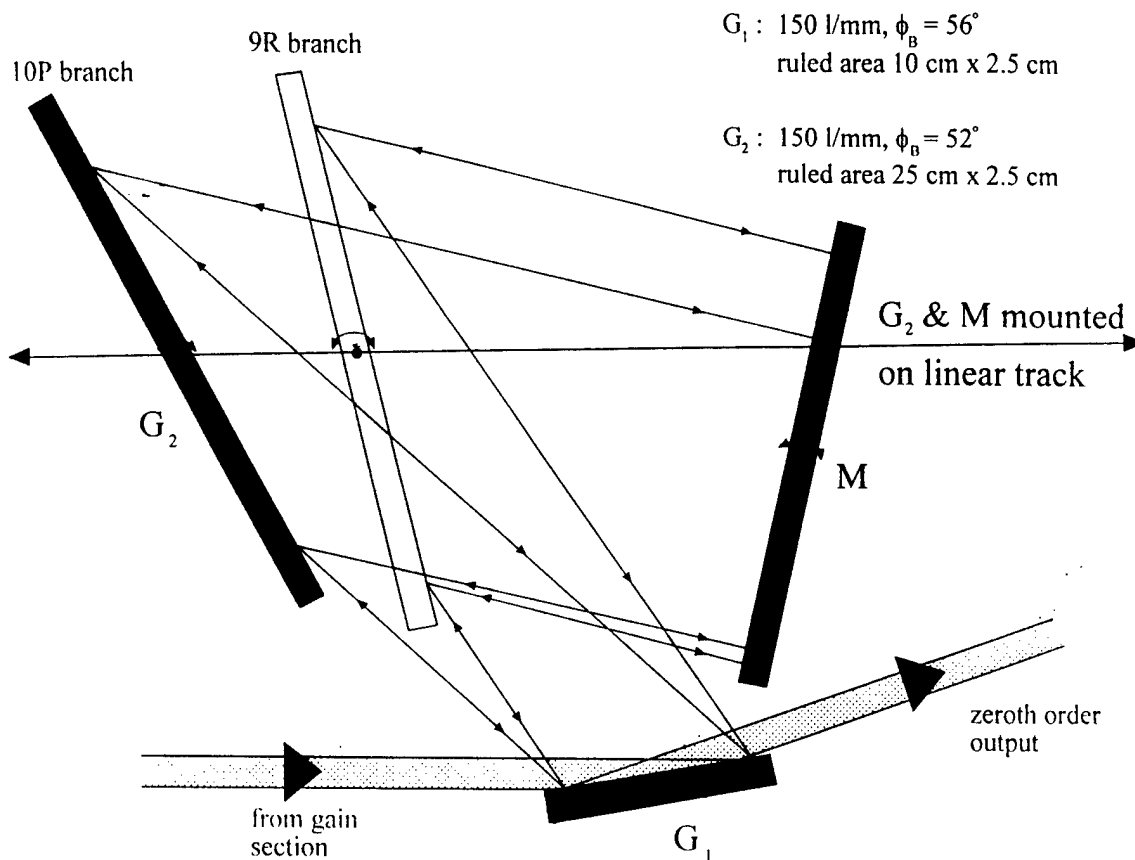

Fig. 14. Mechanical layout of two-grating tuning module.

The retromirror M is mounted on a precision rotation table that is driven by a 25,000 step/rev stepping motor. This combination provides a nominal minimum step of  $1.4 \times 10^{-6}$  rad. With configuration b and both gratings at  $70^\circ$  this corresponds to a frequency step of  $\sim 15$  MHz. Our tests show that jumps corresponding to 10 stepping-motor steps are consistent and reproducible. The rotation tables for both  $G_2$  and M are mounted on a precision translation stage so that the separation between them can be controlled. Tuning in any one branch is accomplished solely by rotation of M, but in order to tune to another branch both rotation and translation of  $G_2$  is also required. The extent of the motion required in order to move between the most widely separated bands, 10P and 9R, is illustrated in Fig. 14.

In order to accommodate the large angles of incidence required for single mode selection the gratings  $G_1$  and  $G_2$  must be very wide. These gratings are ruled on massive copper blocks with dimensions of 12.9 cm x 6.3 cm x 4.9 cm for  $G_1$  and 28.7 cm x 6.2 cm x 7.0 cm. The copper blanks were prepared by

Colorado Precision Products and polished to a flatness of  $\lambda/10$  at  $10 \mu\text{m}$ . The large thickness of the blanks was required to maintain this flatness specification. The gratings were ruled at the Changchun Institute of Optics and Fine Mechanics.  $G_1$  has a ruled area are  $2 \text{ cm} \times 10 \text{ cm}$  and a blaze angle of  $56^\circ$ .  $G_2$  has a ruled area of  $2 \text{ cm} \times 25 \text{ cm}$  and is blazed at  $52^\circ$ . Both gratings have  $150 \text{ l/mm}$ . Performance curves for both gratings are shown in Fig. 17 on page 12.

Computer control is provided for wavelength scanning, to control the laser firing sequence, and for recording and processing the signals from several detectors[8].

### III. REFERENCES

1. P. Repond and M. W. Sigrist, IEEE J. Quantum Electron. 32, 1549-59 (1996).
2. J. C. Petersen and S. E. Choi, J. Opt. Soc. Am. B 8, 2256-59 (1991) and A. Olafsson, M. Hammerich, and J. Henningsen, Appl. Optics 31, 2657-68 (1992).
3. P. Mathieu and J. R. Izatt, Optics Lett. 6, 369-71 (1981).
4. B. K. Deka, J. R. Izatt, and W.-S. Zhu, Proc. Int. Conf. on Lasers'86, 254-257 (1986).
5. P. T. Lang, Infrared Phys. 33, 237-262 (1992).
6. W. Schatz, M. A. Heusinger, R. S. Nebosis, K. F. Renk, and P. T. Lang, Infrared Phys. 34, 339 (1993).
7. A. O. Radkevich, V. B. Fleurov, and J. R. Izatt, IEEE J. Quantum Electron. 32, 679-89 (1996).
8. S. Wang, "Two photon absorption in the far Infrared laser  $\text{CH}_3\text{F}$  spectrum and computer interface for a multiatmosphere  $\text{CO}_2$  pump-laser", MS Thesis, University of Alabama (1997).
9. S. Rai, J. Rai, S. Wang, and J. R. Izatt, paper QWD8, QELS'97, Conference Digest, p. 96 (1997).
10. B. G. Danly, S. G. Evangelides, R. J. Temkin, and B. Lax, IEEE J. Quantum Electron. QE-20, 834 (1984).
11. U. Werling, "Entwicklung eines abstimmbaren Hochleistungslasersystems für die nichtlineare Spektroskopie im fernen Infrarot", Dissertation (Doktorgrad), Universität Regensburg (1988).

12. M. A. Rob and J. R. Izatt, IEEE J. Quantum Electron. **28**, 56-59 (1992).
13. W. Schatz, "Erzeuging intensiver abstimmbarer ultrakurzer Ferninfrarot-Impulse durch optisches Pumpen von Ammoniak und schwerem Wasser", Dissertation (Doktorgrad), Universität Regensburg (1993).
14. M. A. Rob, "Contributions to the development of TEA CO<sub>2</sub> laser sources for high resolution molecular spectroscopy", PhD Dissertation, University of Alabama (1989).
15. J. R. Izatt, M. A. Rob, and W.-S. Zhu, Appl. Optics **30**, 4319-29 (1991).

#### IV. PUBLICATIONS

1. "STRONG-FIELD FOUR-WAVE MIXING IN AN OPTICALLY-PUMPED METHYL FLUORIDE LASER", A.O. Radkevich, V.B. Fleurov, and J.R. Izatt, IEEE J. Quantum Electron., vol. 32, 679-689, (1996).  
ABSTRACT: Continuously tunable coherent radiation in the 9.8-10.1  $\mu\text{m}$  region has been obtained by pumping  $^{12}\text{CH}_3\text{F}$  and  $^{13}\text{CH}_3\text{F}$  with a 10-atmosphere CO<sub>2</sub> laser. Pulse energies up to 2.5 mJ were observed. The experimental conditions were similar to those used for optically-pumped Raman FIR lasers, and simultaneous emission of tunable FIR radiation was also observed. Under some circumstances, a fixed-frequency mid-infrared component was also present. A detailed theoretical analysis of the RFWM process that produces the mid-infrared emission is presented. It is based on a six-level density matrix model. The importance of FIR cascade and refilling transitions, as well as double-Raman transitions, is demonstrated. Contributions to the MIR gain resulting from both degenerate and nondegenerate parametric processes are analyzed. The pressure dependence of the MIR emission was studied, both theoretically and experimentally, and the possibility of pressure switching between tunable and fixed-frequency operating modes is discussed.
2. "CONTINUOUSLY-TUNABLE SINGLE-MODE TWENTY-ATMOSPHERE CO<sub>2</sub> LASER", Jerald R. Izatt, Wolfgang Schatz, and Vladimir B. Fleurov, Int. Conf. on Millimeter and Submillimeter Waves and Applications III, SPIE Vol. 2842, Ed. M. M. Afsar, pp. 78-89 (1996).

**ABSTRACT:** Multi-atmosphere CO<sub>2</sub> lasers can provide continuous gain over bands 20 to 30 cm<sup>-1</sup> wide in each R and P branch of the 00<sup>o</sup>1 -10<sup>o</sup>0 and 00<sup>o</sup>1 - 02<sup>o</sup>0 bands, covering ~60% of the 9.2-10.8 mm region. By contrast, the spectrum of a typical low pressure CO<sub>2</sub> lasers is 99% empty. We describe design studies and the construction of a 20-atmosphere laser that will operate on a single longitudinal mode and provide mode-to-mode tunability, thus effecting a useful compromise between the narrow-line capability of a low pressure laser and the broad tunability of a multi-atmosphere laser. One important application of this laser is to pump double-Raman processes in methyl fluoride which will shift the narrow linewidth and tunability to the 150 to 650 μm region of the far infrared.

3. "LASING WITHOUT INVERSION IN A FOUR-LEVEL RAMAN SYSTEM",  
Suranjana Rai, Jagdish Rai, S. Wang, J.R. Izatt, Paper QWD8, QELS '97, Conference Digest, p. 96 (1997)

**ABSTRACT:** We demonstrate the existence of lasing without inversion at far-infrared frequencies in the emission from ro-vibronic levels of the CH<sub>3</sub>F molecule. The gain mechanism is found to be related to quantum interference effects in the four-level Raman system.

4. "LASING WITHOUT INVERSION IN A FOUR-LEVEL RAMAN SYSTEM",  
Suranjana Rai, Jagdish Rai, S. Wang, and J.R. Izatt, (submitted to Phys. Rev. Lett.).

**ABSTRACT:** In this paper we show the existence of lasing without inversion in a four-level far-infrared Raman laser. We find that quantum interference is at play in the two alternate paths connecting the lower state of the system. Our theoretical calculations are applied to the practical case of the CH<sub>3</sub>F molecule where high off-resonant gain is known to exist at FIR frequencies. Our results indicate a strong dependence on pump detuning and the strength of the pump field. Lasing without inversion is found to exist under off-resonant pumping with moderate to strong pumping conditions.

5. "TWO PHOTON ABSORPTION IN THE FAR INFRARED CH<sub>3</sub>F LASER AND COMPUTER INTERFACE FOR A MULTIATMOSPHERE CO<sub>2</sub> PUMP LASER",

Shuoqin Wang, Master of Science Thesis, University of Alabama, 1997.

ABSTRACT: Two photon absorption (TPA) in the CH<sub>3</sub>F laser is investigated. A 4-level density -matrix model is used. The results show the dependence of the strength and linewidth of TPA on pump intensity, FIR emission intensity, J-number, and the homogeneous linewidth of the FIR transition. Initial optical testing of a single-longitudinal mode, 20-atmosphere CO<sub>2</sub> laser, which will be used in TPA experiments is described. Pump laser linewidth and tuning characteristics are presented. Linewidths down to 200 MHz with pulse energies of 100 mJ have been observed.

V. LIST OF SCIENTIFIC PERSONNEL

- |                          |   |
|--------------------------|---|
| Dr. Jerald R. Izatt,     | Professor Emeritus, Department of Physics and Astronomy, University of Alabama, Tuscaloosa, AL, 35487-0324    |
| Dr. Wolfgang Schatz      | Max-Born Institut für Nichtlineare Optik und Kurzzeitspektroskopie, Rudower Chausee 6, D12489 Berlin, Germany |
| Dr. Vladimir B. Fleurov  | Physics Department, University of Alabama at Birmingham, Birmingham, AL, 35294                                |
| Dr. Andrey. O. Radkevich | present address unknown   |
| Shuoqin Wang             | Department of Physics and Astronomy, University of Alabama Tuscaloosa, AL, 35487-0324                         |

DEGREE EARNED

- |              |  |
|--------------|--|
| Shuoqin Wang | Master of Science, Physics University of Alabama, 1997 |
|--------------|--|