

AD \_\_\_\_\_



REPORT NO. 5059B

MM&TE - APPLICATION OF RADAR TO BALLISTIC  
ACCEPTANCE TESTING OF AMMUNITION (ARBAT)  
PHASE B: ANTENNA DEVELOPMENT/FABRICATION

FINAL REPORT (PHASE B)

CDRL: A002

TECHNICAL  
LIBRARY

30 September 1976

SARPA-QA-A-R

PICATINNY ARSENAL  
DOVER, NEW JERSEY 07801

DRCMS CODE: 4932.05.4139.1

CONTRACT NO. DAAA21-73-C-0664

19970722 018

Distribution of the document is unlimited.  
The findings in this report are not to be construed as an official Department of Army position.  
Destroy this report when no longer needed. Do not return it to the originator.

ITT GILFILLAN  
7821 Orion Avenue  
Van Nuys, California 90406

CONFIDENTIAL STATEMENT A  
Approved for public release  
Distribution Unlimited

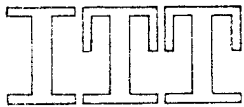

5/14/76  
ASO

International Telephone and  
Telegraph Corporation

*ITT Gilfillan*

Defense-Space Group

7821 Orion Avenue, P.O. Box 7713

Van Nuys, California 91409

Telephone (213)988-2600

Telex 651421•TWX 910-495-1787

November 8, 1976

In Reply Refer To:  
297/5059/94/ASO

Department of the Army  
Headquarters, Picatinny Arsenal  
Dover, New Jersey 07801

Attention: Code SARPA-QA-A-R

Subject: Contract DAAA21-73-C-0664  
Data Item A002 - Final Technical Report  
for Mfg. Methods & Technology: Application of Radar to  
Ballistic Acceptance Testing of Ammunition (ARBAT)  
AMCMS Code 4932.05.4139.1

Gentlemen:

In accordance with CLIN 0002 of the subject contract, ITT Gilfillan is herewith submitting the Final Technical Report for the ARBAT Phase "B" Program to the Appendix B Report Distribution List as required.

The document incorporates all comments and modifications to the draft report previously submitted to you, and its submittal hereby completes the requirements of the subject contract.

If there are any further inquiries regarding this report, please contact the undersigned.

Very truly yours,

A. S. Ostrom  
Sr. Contract Administrator

ASO:pk  
Enclosure: a/s

Distribution: See Attached Sheet

cc: DCAS/VN, Attn: W. W. Sodeman (w/o encl.)  
DCAS/VN, Attn: O. D. North (w/o encl.)

## ABSTRACT

The ARBAT (Application of Radar to Ballistic Acceptance Testing of Ammunition) radar system is presently being developed by Picatinny Arsenal for range instrumentation purposes. This report covers the development of the antenna subsystem through range testing of a 9-element test array and assembly of the full antenna. The subject antenna is a 10 x 12 ft phase/frequency/mechanical scanning X-band planar array. Elevation scanning is by means of phase variation obtained by program controlled 4-bit diode phase shifters. In addition to the electronic scanning capability, a manual tilt capability is included to accommodate range terrain variations. Azimuth scanning is accomplished by frequency variation, and limited mechanical rotation of the array by servo control. Mechanical rotation is limited to  $\pm 170$  degrees which fulfills the requirements of the application. The transmitter/receiver unit is mounted on the antenna back structure. Connections to and from the transmitter/receiver and phase shifter control electronics are made through a "windup" cable arrangement eliminating the need for slip rings. The array is made up of 167 horizontal dual-slot pair radiators fed by a vertical feed line.

The antenna incorporates a performance monitoring feature which functions as a confidence indicator and as a means for fault location down to the single horizontal array level. This feature is implemented by means of coupling each horizontal array, opposite the feed end, to a vertical combiner, or performance monitor line. Residual RF energy in the radiating sections is combined and detected to monitor array performance. Simple diagnostic phase shifter exercising programs facilitate fault location.

## TABLE OF CONTENTS

<u>Section</u>	<u>Page</u>
ABSTRACT	iii
FOREWORD	v
1. DEVELOPMENT APPROACH	1
1.1 Overall Characteristics	1
1.1.1 General Description	1
1.2 Detailed Requirements	9
2. DESIGN DESCRIPTIONS	18
2.1 Back Structure	19
2.2 Horizontal Array Waveguide Sections	24
2.3 Vertical Feed Line	35
2.4 90 Degree Twist Crossguide Coupler Section	40
2.4.1 Load: Termination (Vertical Feed Coupler)	44
2.4.2 Phase Randomization Blocks	46
2.5 Diode Phase Shifter	51
2.6 ARBAT Antenna Performance Monitor Concept	54
2.6.1 Performance Monitor Line	56
2.6.2 Loads: Performance Monitor Line	61
3. TEST PROGRAM	63
3.1 Short Array (3 Section) Tests	63
3.2 Nine-Element Test Array	68
3.2.1 Test Patterns	69
4. SUMMARY OF TEST RESULTS	82
APPENDIX A	83
REPORT DISTRIBUTION	105
REPORT DOCUMENTATION PAGE	109

## LIST OF ILLUSTRATIONS

<u>Figure</u>		<u>Page</u>
1.	ARBAT Phase Antenna Development Sequence	2
2.	System Configuration Concept	4
3.	Back Structure/Transceiver Mounting	5
4.	Antenna Signal Flow Graphic Schematic	6
5.	Antenna Assembly Front Array View	7
6.	Antenna Assembly Rear View	8
7.	Back Structure Truss Elements	21
8.	Back Structure/Transceiver Mounting	22
9.	Computer Deflection Analysis	23
10.	Insertion Phase Measurement/Comparison Test Setup	26
11.	Insertion Phase Plot (After Etching Process)	27
12.	Phase Error Plot (2nd Aperture Excitation at 9.3 GHz)	29
13.	Phase Error Plot (2nd Aperture Excitation at 9.65 GHz)	30
14.	Phase Error Plot (3rd Aperture Excitation at 10 GHz)	31
15.	Amplitude Plot (1st Aperture Excitation at 9.65 GHz)	32
16.	Amplitude Plot (2nd Aperture Excitation at 9.3 GHz)	33
17.	Amplitude Plot (3rd Aperture Excitation at 20 GHz)	34
18.	Vertical Line Feed in Assembled Antenna	36
19.	Vertical Line Feed Insertion Loss vs Frequency	37
20.	VSWR vs Frequency: Line Feed Section #3	38
21.	VSWR vs Frequency: Line Feed Section #3 (Expanded Scale)	39
22.	Ninety Degree Twist Crossguid Coupler in Assembled Antenna	41
23.	Ninety Degree Twist Crossguide Section	42
24.	Ninety Degree Twist Section VSWR Plot	43
25.	Load: Vertical Feed Coupler VSWR Plot	45
26.	Phase Randomization Block Location in Coupler	47
27.	Phase Randomization Block Series	48
28.	Phase Randomization Block	49
29.	Phase Randomization Block	50
30.	Phase Shifter Decode Logic Organization	52
31.	Phase Shifter Position in Assembled Antenna	53
32.	Performance Monitoring Concept	55
33.	Performance Monitor Slot Dimensions	57
34.	Slot Coupling Values	58
35.	Performance Monitor Line in Assembled Antenna	59
36.	Performance Monitor Line (Close-Up View)	60
37.	Load Block VSWR Measurement	62

LIST OF ILLUSTRATIONS (Continued)

<u>Figure</u>		<u>Page</u>
38.	Horizontal Array Element Insertion Loss (Dual Slot Radiators)	64
39.	Horizontal Array Element Return Loss (Dual Slot Radiators)	65
40.	D-2 Horizontal Array Element Return Loss (Expanded D2 RL)	66
41.	Predicted Pattern (3 Element Test)	67
42.	Nine-Element Test Array Assembly	69
43.	Nine-Element Test Array Assembled	70
44.	Nine-Element Test Array Elevation Scan	71
45.	ARBAT 9-Element Test Array Pattern (9.30)	72
46.	ARBAT 9-Element Test Array Pattern (9.65)	73
47.	ARBAT 9-Element Test Array Pattern (10.0)	74
48.	ARBAT 9-Element Test Array Pattern (9.3)	75
49.	ARBAT 9-Element Test Array Pattern (9.65)	76
50.	ARBAT 9-Element Test Array Pattern (10.0)	77
51.	ARBAT 9-Element Test Array Pattern (9.3)	78
52.	ARBAT 9-Element Test Array Pattern (9.65)	79
53.	ARBAT 9-Element Test Array Pattern (10.0)	80
54.	ARBAT 9-Element Test Array Pattern (9.65)	81

## ARBAT ANTENNA

### 1. DEVELOPMENT APPROACH

The ARBAT system required the development of an antenna to meet the unique performance requirements of ballistic ammunition testing. The approach followed for this development was standard in antenna design; a paper design was first generated by means of computer analyses. Input data for these analyses were based on proven design parameters generated for similar antennas produced for other programs. An iterative process, in which a single element followed by multiple horizontal array elements were fabricated, tested and modified as necessary to optimize configuration, was followed. A detailed illustration of the development/fabrication sequence followed with the ARBAT antenna is shown in Figure 1.

#### 1.1 Overall Characteristics

1.1.1 General Description. - The antenna is a planar array design with an aperture of 10 ft x 12 ft. Beam scanning is accomplished by a combination of electronic and mechanical means. The beam is scanned in elevation by four-bit diode phase shifters (GFE), whereas azimuth scanning is by frequency variation and mechanical rotation of the array. The mechanical rotation capability is limited to a maximum of  $\pm 170$  degrees which fulfills the requirements in ammunition testing applications. Provisions are included in the antenna back structure design for a mechanical adjustment (tilt) of 0 to 25 degrees in elevation. The back structure is designed to support the microwave assembly, phase shifter power supplies and logic, and the transmitter/receiver unit. In view of the less than 360 degree rotation required ( $\pm 170^\circ$ ), a cable "windup" scheme is used for power and all input/output lines to and from the antenna which obviates the need for slip rings. The artists sketch in Figure 2 illustrates the overall system configuration concept. A more detailed view illustrating the back structure concept is shown in Figure 3. The array contains 167 dual slot horizontal radiators which are fed by a single vertical feed line via 90-degree waveguide twist and offset sections followed by 4-bit diode phase shifters. The arrays terminate at a vertical performance monitor line at the end opposite the feed line. The performance monitor line is a part of the performance monitor and fault location feature incorporated in the system design. Antenna performance determination is accomplished by the measurement of residual RF energy at the extreme ends of the horizontal arrays (opposite the feed ends). Coupling from the vertical feed line to the arrays and from the arrays to the performance monitor line is by 4-port coupler



## NOTES TO FIGURE 1

### NOTE 1:

Fabrication of "dummy" phase shifter waveguide sections with Rexolite phase shifting block inserts for substitution in place of the diode phase shifters which were not available at the time the tests were required. The Rexolite blocks provide a step transformer with a maximum VSWR of 1.1:5. The phase shift increments of the Rexolite block/waveguide section units were adjusted to  $\pm 3$  degrees by the application of dielectric tape directly to the side of the block; phase shift was then measured at center frequency.

### NOTE 2:

A nine element test array was assembled using the array elements, short feed, waveguide twist sections, dummy phase shifter blocks and couplers prepared earlier. These elements were assembled into a test support to simulate the final full array configuration except with a reduced number of array elements. This test assembly was then moved to the test range for the tests described later in this report.

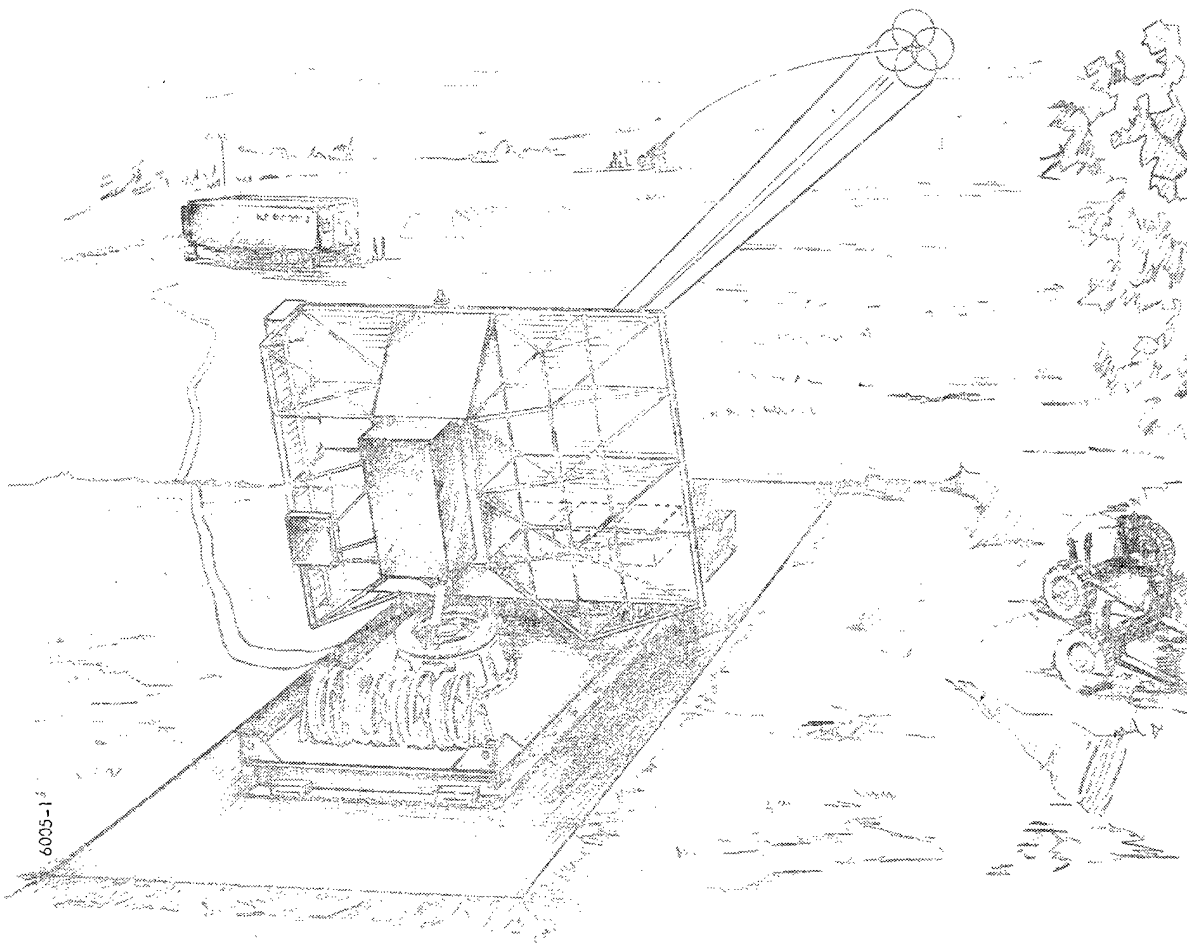

Figure 2. System Configuration Concept

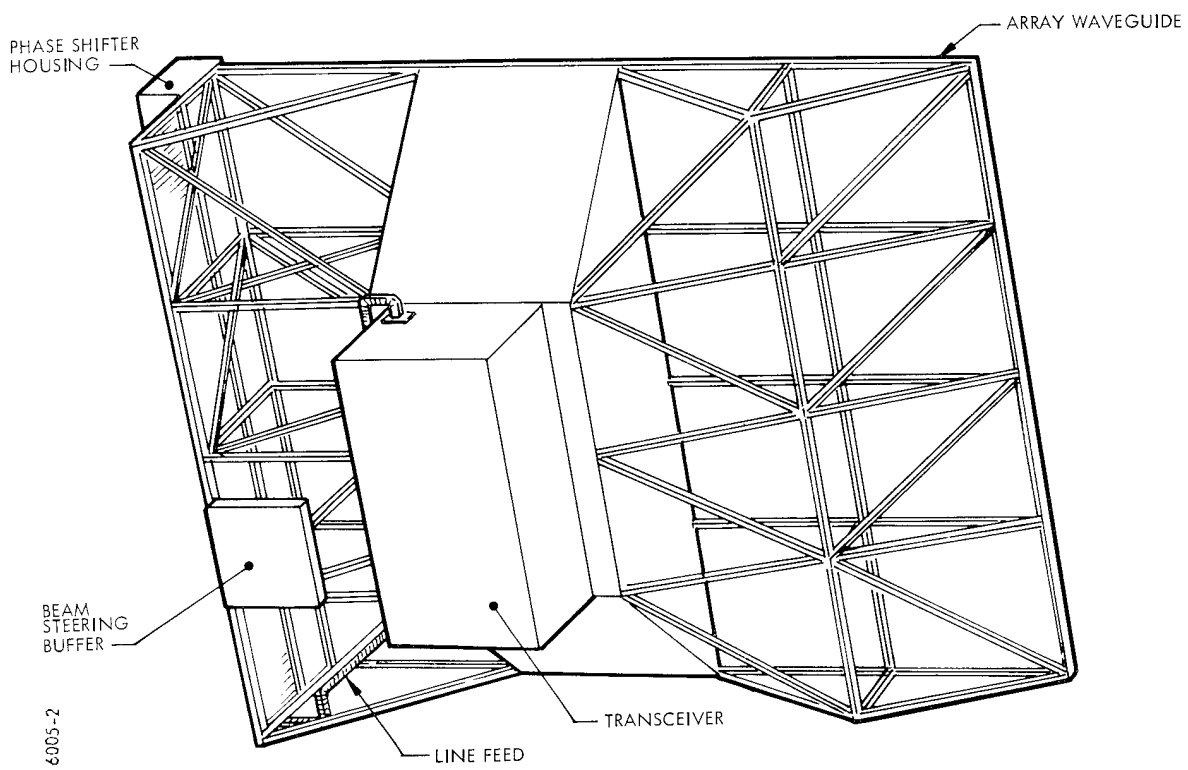

Figure 3. Back Structure/Transceiver Mounting

sections. Coupling sections at the feed end contain end loads and phase randomization blocks. The 4-port couplers at the performance monitor line section are designed with a common flange which mates with the individual flanges at the output ends of each horizontal array element. The performance monitor feature is implemented by terminating the lower end of the vertical performance monitor line section with a crystal video detector whose output is routed via coaxial cable to the monitoring circuitry. A pictorial drawing showing microwave element configuration and signal flow illustrates the basic antenna physical design, Figure 4.

The two photographs following show the assembled antenna microwave section. The front side showing the horizontal array elements, Figure 5; and the rear of the assembly showing back structure details, vertical feed line, 90 degree twist waveguide sections, and phase shifters is shown in Figure 6.

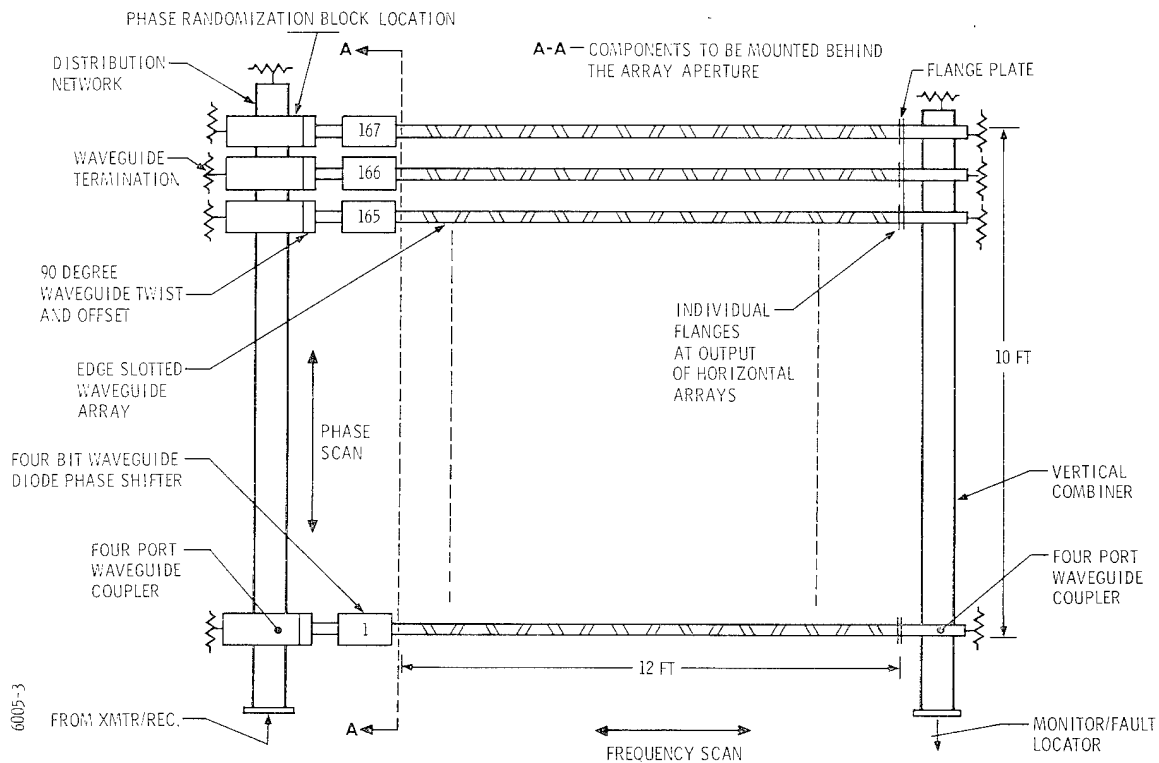
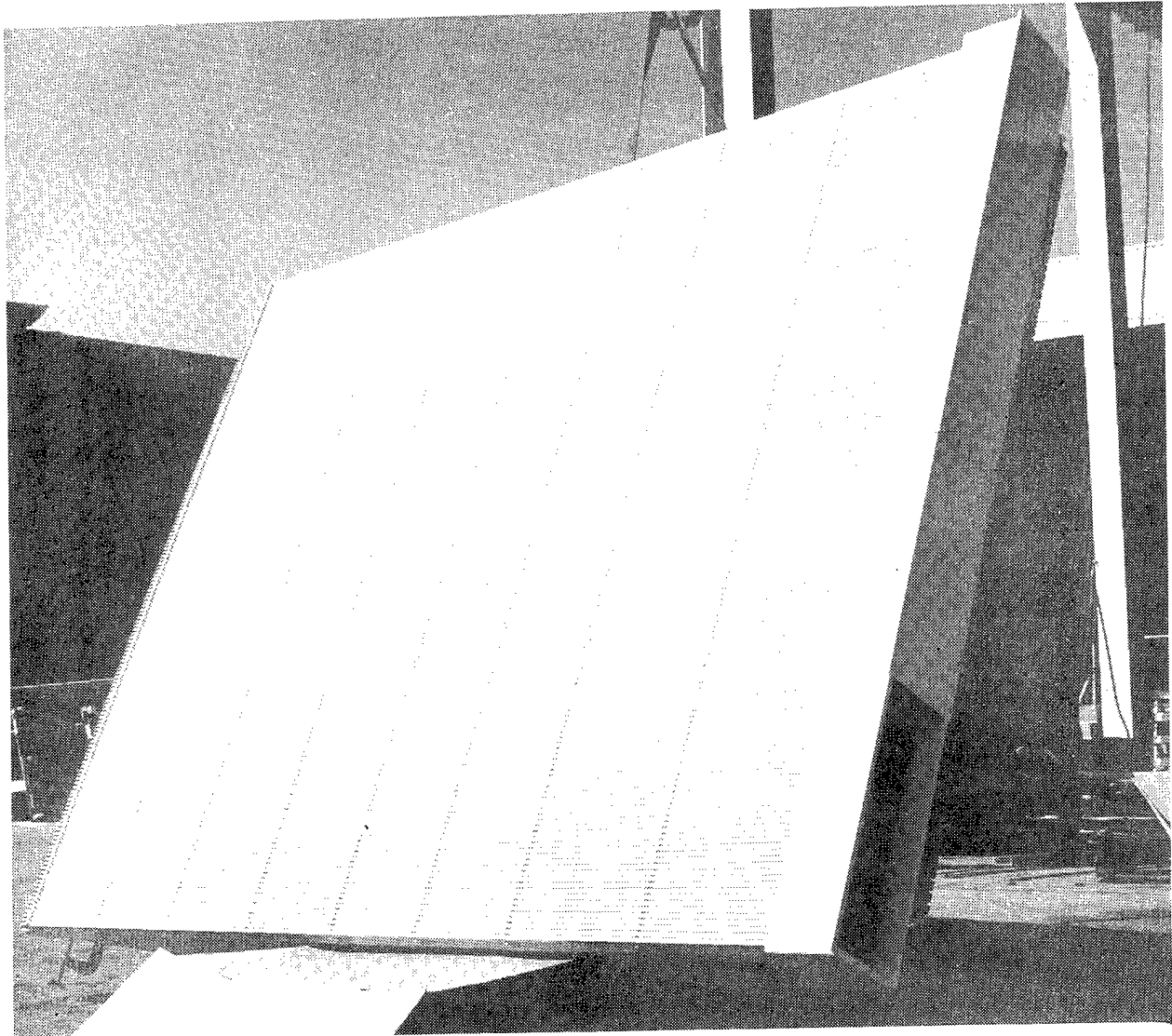
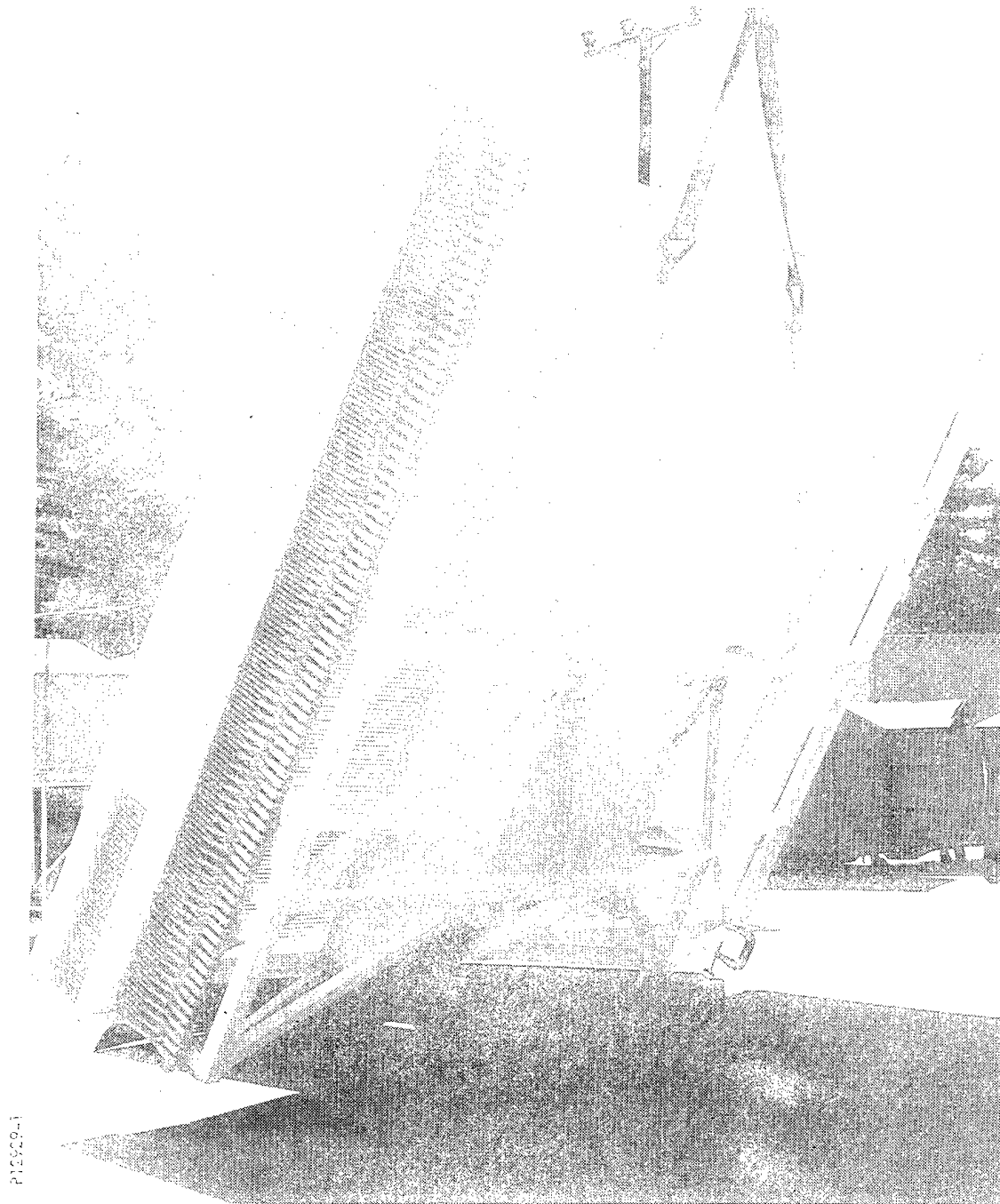

Figure 4. Antenna Signal Flow Graphic Schematic



P12927-1

Figure 5. Antenna Assembly Front Array View



P1229-1

Figure 6. Antenna Assembly Rear View

## 1.2 Detailed Requirements

The following extracts from Appendix A of the contract Statement of Work, include the basic performance requirements placed on the antenna to be achieved when mounted on a suitable pedestal with servo control and when coupled to the modified GFE transmitter for which the antenna has been designed. Pedestal assembly and transceiver modifications are parts of forthcoming program phases.

1.0 Beam Steering

1.1 Electrical

1.1.1 Azimuth: 7.7 degrees minimum

1.1.2 Elevation:  $\pm 35$  degrees minimum

1.2 Mechanical

1.2.1 Azimuth:  $\pm 170$  degrees rotation minimum at  $40 \text{ degrees / sec}^2$  while maintaining pointing accuracy during rotation.

The electrical beam motion shall be accomplished with diode phase shifters in elevation and with frequency scanned slotted waveguide radiators in azimuth. The antenna shall be designed for electrical sequential lobing. Provision shall be made for a mechanical adjustment capability in elevation. The angle between the horizontal position and the beam normal of the antenna shall have an adjustable range of 0 to  $25^\circ$ .

2.0	Electrical Requirements	
2.1	Detailed Specification	
2.1.1	Frequency Band - X	
2.1.2	Center Frequency - See Note 1	
2.1.3	Bandwidth for Frequency Scan - See Note 1	
2.1.4	Azimuth Scan (Electrical): $7.7^\circ$	
2.1.5	Elevation Scan (Electrical): $\pm 35^\circ$	
2.1.6	Bandwidth, 3 dB (Note 2)	
	Azimuth	for $0^\circ$ elevation .55 $^\circ$
		for $\pm 35^\circ$ elevation .67 $^\circ$
	Elevation	for $0^\circ$ elevation .66 $^\circ$
		for $\pm 35^\circ$ elevation .81 $^\circ$
2.1.7	Beam Pointing Error, Electrical	
	Elevation	.37 mrad
2.1.8	Electronic Beam Switching Time in Elevation	1.0 MHz
2.1.9	Polarization	Horizontal

NOTE 1: As stated in antenna design specification. (Contract DAAA21-72-C-0725)

- 2.1.10 Sidelobe Level (Note 2)
- |           |                    |        |
|-----------|--------------------|--------|
| Azimuth   | at 0° elev. scan   | -25 dB |
|           | at ±35° elev. scan | -23 dB |
| Elevation | at 0° elev. scan   | -25 dB |
|           | at ±35° elev. scan | -23 dB |
- 2.1.11 Terminal Gain at 0° Elev. scan  
at Center Frequency 46.0 minimum  
(Note 3)
- Terminal Gain at ±35° Elev. scan  
at Center Frequency 45.0 dB (Note 3)
- 2.1.12 Power Capability peak 30 kw  
average 300 w
- 2.2 Major Subassemblies
- 2.2.1 For description and characteristics of GFE phase shifters see Picatinny Arsenal Document Technical Description TDPA-QAAR-2340.
- 2.3 Techniques Used
- 2.3.1 Wideband Operation for Frequency Scan
- Appropriate techniques shall be applied to suppress the grating lobes and improve the radiation pattern while operating over the maximum bandwidth necessary for the frequency scan in azimuth.
- 2.3.2 Phase Randomization
- To avoid the quantization error of the 4-bit phase shifter and the associated increase in sidelobe level, an appropriate phase randomization technique shall be used for each element of the horizontal array. The antenna buffer shall be able to compensate for this additional insertion phase.

NOTE 2: These parameters will be achieved at the center frequency.

NOTE 3: Based on an average phase shifter insertion loss of 2.5 dB.

### 2.3.3 Signal Coupling

To generate an optimum pencil beam with the most efficient low sidelobe pattern, proper weighting (30 dB Taylor excitation (N=4)) shall be applied by specifying appropriate coupling apertures from the vertical feed to the horizontal arrays and in establishing the slots in the horizontal elements.

### 2.3.4 CW Mode

The requirements for a CW mode of operation, to be added in the future, should be considered during the fabrication and design modifications of the antenna.

## 2.3 Mechanical Requirements

### 2.3.1 General Mechanical Requirements

2.3.1.1 The antenna array and its supporting structure shall be of sufficient rigidity and strength to minimize the deflection when subjected to the required acceleration and wind loading. When assembled on an appropriate servo mount pedestal (AN/SPS-48 or equivalent) and when subjected simultaneously to  $40^{\circ}/\text{sec}^2$  acceleration in azimuth and 20 mph wind load, the antenna system shall exhibit no more than the following maximum deflection of the beam:

	BASIC ANTENNA (PHASE B)	ANTENNA + PEDESTAL + VEHICLE (PHASE C)
a. Azimuth	.377 mrad max.	.660 mrad max.
b. Elevation	.184 mrad max.	.690 mrad max.

2.3.1.2 The antenna shall be properly designed, fabricated and assembled to permit electrical and mechanical operation in accordance with this and the complete ARBAT radar system specifications when subjected to the environmental conditions specified in paragraph 2.8.

In a non-operative state, the antenna system shall be sufficiently rugged to withstand, without damage, vibration and shock during transportation per paragraphs 2.7 and 2.8, and wind loads and precipitation per paragraph 2.8.

2.3.2 Detailed Mechanical Specifications

- 2.3.2.1 Antenna Aperture Size: Height - 120 ins.  
Width - 144 ins.
- 2.3.2.2 Total Antenna Width - 154 ins. (ref)
- 2.3.2.3 Adjustable Elevation Tilt 0 to 25°
- 2.3.2.4 Mechanical Pointing Accuracy  
(deflection error due to all  
loading, see para 2.3.1.1) az - .377 mrad max.  
el - .184 mrad max.
- 2.3.2.5 Maximum Weight (Antenna,  
transceiver, buffer, power  
supplies, cables) without  
pedestal 1700 lbs. max

2.3.3 Antenna Microwave Hardware

The antenna shall include, but not be limited to, the following microwave hardware:

- 2.3.3.1 Vertical Feed Line
- 2.3.3.2 90° Waveguide Twist (167)
- 2.3.3.3 Diode Phase Shifters (167)
- 2.3.3.4 Mounting Plate(s) for Phase Shifters
- 2.3.3.5 Horizontal Slotted Array Element (167)
- 2.3.3.6 Required coupling Elements, straight and angular (167 each)

2.3.4 Mechanical Mounting Structure

The microwave elements shall be securely mounted to a back structure.

2.3.5 Protective Enclosures

2.3.5.1 A protective enclosure (cover) shall be provided for the phase shifters.

2.3.5.2 Weather-resistant, electrically non-interfering plastic tape (tedlar-mylar or equivalent) shall cover the antenna radiating slots and prevent entrance and accumulation of water, sand and dust in the microwave elements.

2.3.5.3 The contractor shall supply a waterproof, soft plastic or coated or impregnated cloth hood to protect the antenna while not operated or while in storage.

#### 2.3.6 Protective Finishes

The exterior surfaces of the antenna system (waveguides, mounting structure, enclosures, transceiver) shall be covered with protective coating. The color shall be silver or white, to minimize the heating due to solar radiation. The interior surfaces shall have appropriate corrosion-resistant finish.

#### 2.3.7 Material Compatibility

Different materials in contact with each other shall be chosen with careful regard to the electrochemical series so that they are compatible and will not corrode because of electrical potential differences.

#### 2.4 Testing

The contractor shall perform the following tests:

2.4.1 Laboratory tests for microwave components (vertical feed, horizontal array elements, etc).

2.4.2 Laboratory and range tests for the 9-element test array.

#### 2.5 Calibration

All instrumentation used for laboratory and range testing shall be properly calibrated with standards traceable to the National Bureau of Standards.

2.6 Maintenance

For ease of maintenance, electrical and microwave components shall be mounted so as to permit field testing and replacement by qualified personnel.

2.7 Mobility/Transportability

2.7.1 In the next phase (C), the antenna system will be mounted on a servo pedestal located on an antenna vehicle. The vehicle will be transported by public highways and/or railroads between proving grounds. Within the proving grounds, graded, light duty, hard surface roads will be used. However, the system shall be capable of being moved at low speeds (5 mph) on unimproved dirt roads. The antenna system shall be able to withstand, without damage, the above transportation requirements.

2.7.2 During transportation within the proving grounds the overall system height shall be less than 16 feet, 12 feet desired. If it is necessary to lower the antenna to meet this requirement, the lowering mechanism shall be self-contained and hydraulically or hand operated. The width of the system during transportation shall not exceed 8 feet. When moving from site to site within the proving grounds, a maximum set-up time of 8 hours is required, four hours desired.

2.7.3 For transportation between proving grounds, it shall be possible to deploy the system into a configuration transportable over public roads and compatible with applicable federal, state and local regulations. If necessary, subsystem may be removed or lowered from the main assembly with the aid of a crane (to be provided by Proving Grounds).

2.8 Environmental Requirements

2.8.1 Temperature

The antenna system shall be capable of operating in an ambient air temperature range of  $-65^{\circ}\text{F}$  to  $+165^{\circ}\text{F}$  and maintaining the accuracy requirements specified in section 2 for an ambient air temperature range of  $-20^{\circ}\text{F}$  to  $+120^{\circ}\text{F}$ .

2.8.2 Wind

The antenna system shall be capable of operating and maintaining the accuracy requirements specified in section 2 in winds up to 30 mph. In addition, when the antenna is secured and not operating, it shall be capable of withstanding winds up to 75 mph.

2.8.3 Precipitation (Rain, Snow, Hail, Ice)

The antenna system shall be properly designed and fabricated to prevent limitation in accuracy and operational capability caused by internal leakage and accumulation of precipitation. The effects of external accumulation should be kept as low as possible by proper design.

2.8.4 Humidity

The antenna system shall be properly designed and fabricated to prevent deterioration of system performance due to humidity encountered in the continental United States.

2.8.5 Sand and Dust

The antenna system shall be properly designed and fabricated to prevent sand and dust particles from entering the interior of the system, accumulating there and causing electrical and/or mechanical interference.

2.8.6 Solar Radiation

The antenna system shall be designed to operate under extreme environmental conditions with a solar load of 360 BTU per square foot per hour taken at the worst orientation of the sun relative to the equipment. To limit the heating effect, the antenna system shall have an exterior reflective color of silver or white.

2.8.7 Shock

The antenna system, when properly mounted on servo pedestal and antenna vehicle, shall be able to withstand the effects of a 10g shock environment (any direction)

during transit by truck. The equipment shall be designed to withstand humping loads common to rail transportation.

2.9 Reliability

The reliability of the antenna system shall be sufficiently high to permit achievement of the desired objective:

MTBF for the entire radar system - 200 hours.

## 2. DESIGN DESCRIPTIONS

The following sub-sections provide brief descriptions of the major components in the ARBAT antenna design. Detailed physical descriptions are generally not included in this section, except that in some instances basic dimensions are included on sketches to provide the reader with sufficient information to facilitate visualization of the component described.

Test results for critical parameters are included for those components where such tests are applicable.

Drawings for the antenna are packaged separately from this report (3 copies supplied to Picatinny Arsenal and requests for copies should be made there).

The following drawings are available at Picatinny Arsenal.

	<u>Drawing</u>	<u>Component/Assembly</u>
1.	140300-1	Antenna Assy, ARBAT
2.	140301-1	Back Structure, Antenna
3.	140311-1	Twist, 90°, W/G
4.	140309-2	Array Assy, W/G
5.	140309-2	Parts List
6.	140312-1	Flange
7.	140312-2	Flange
8.	140307-1	Feed Line
9.	140313-1	Load Assy
10.	140310-1	Comb
11.	140310-2	Comb
12.	140317-1	Comb
13.	140317-2	Comb
14.	140315-1	Structure
15.	140328-1	Bracket
16.	140328-2	Bracket

	<u>Drawing</u>	<u>Component/Assembly</u>
17.	140316-1	Panel
18.	140318-1	Bracket
19.	140319-1	Block
20.	140320-1	Retainer
21.	140308-1	Monitor
22.	140325-1	Load
23.	140321-1	Cover
24.	140322-1	Cover
25.	140323-1	Cover
26.	140324-1	Angle
27.	140302-1	Support
28.	140303-1	Support
29.	140304-1	Support
30.	140304-2	Support
31.	140305-1	Base
32.	140306-1	Clevis
33.	140326-1	Rod End
34.	140327-1	Clevis

## 2.1 Back Structure

The antenna back structure is a rigid welded aluminum (6061-T6) structure designed to support the microwave elements of the antenna with the associated phase shifter drive electronics and the transmitter/receiver. The structure is designed for mounting on a rotating pedestal which will provide the mechanical portion of the required beam scanning capability. A non-scalar structural schematic sketch is used for clarity in Figure 7 to illustrate the basic construction of the back support.

A full view, artists sketch, of the backside of the antenna with the transmitter/receiver mounted shows the position of the transceiver/mounting, Figure 8.

The measured weight of the completed back structure is 722.0 pounds which includes the array positioning combs.

The obvious prime requirement for the back structure is rigidity and desirably the rigidity should be achieved with reasonably light-weight. Computer deflection analysis results are shown in Figure 9.

The mechanical structure analysis for the total antenna structure is contained in Appendix A.

6005-6

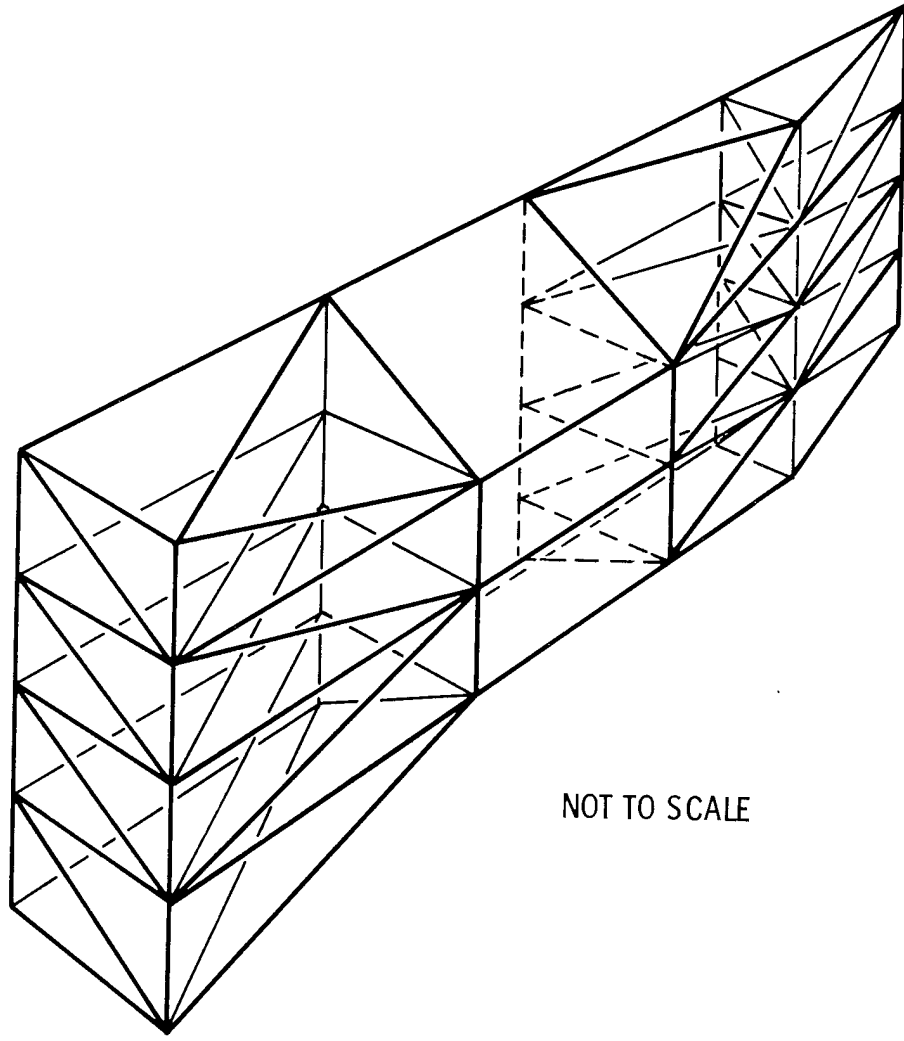

Figure 7. Back Structure Truss Elements

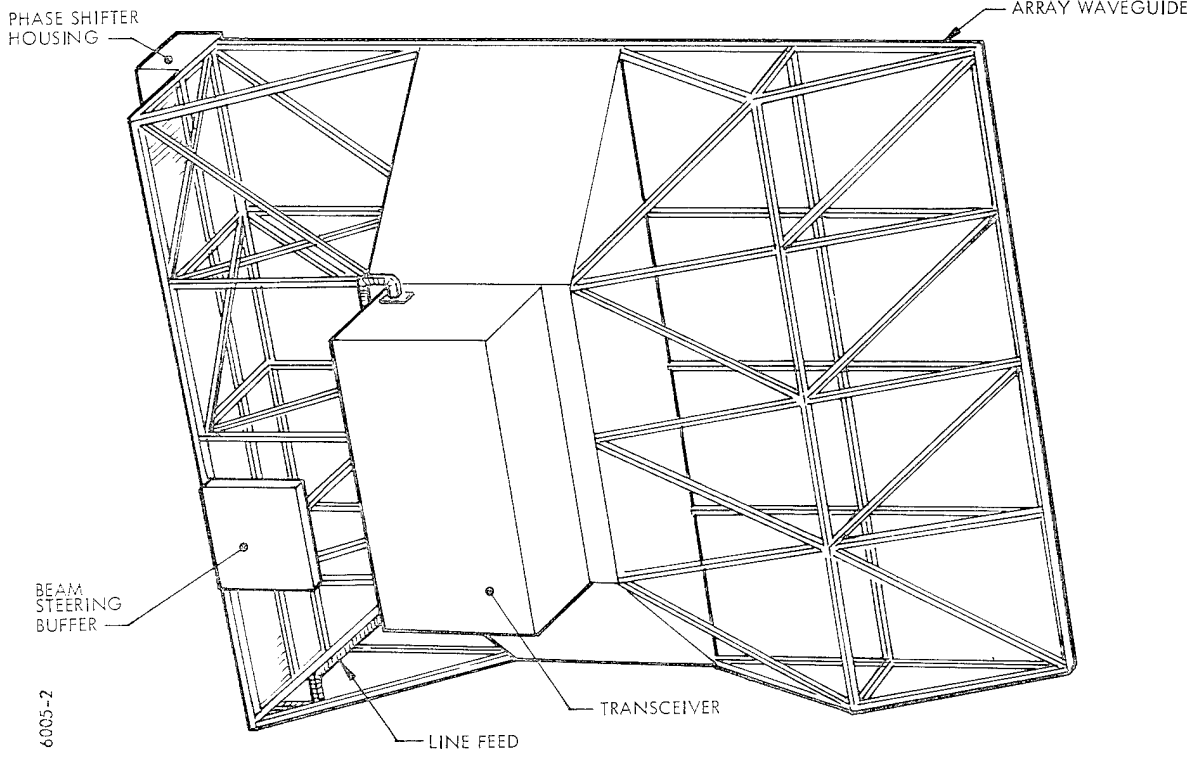

Figure 8. Back Structure/Transceiver Mounting



## 2.2 Horizontal Array Waveguide Sections

The radiating elements in the ARBAT antenna are horizontal array waveguide sections. Radiation is via dual pairs of slots milled in the narrow dimension side. Array waveguide sections are fabricated from thin wall precision waveguide made from 6061-T6 aluminum alloy conforming to MIL-W-85/6 requirements. This waveguide is 0.400 by 0.750 inches inside and 0.476 by 0.826 inches outside. Each array section is 145.86 inches in length and contain 161 dual slot pairs (322 milled slots) in the narrow dimension radiating edge. Each individual array section is fitted with a flange at each end for mating with a diode phase shifter at the feed end and with a coupler flange plate at the opposite or performance monitor end. The flanges are welded at each corner to the mating waveguide and the remaining area of contact is then sealed.

Before assembly of the horizontal array sections, the slotted side is covered with a multi-layer RF transparent tape (G. T. Schjeldahl Co., Type G.133500-014) and all surfaces are eventually painted with white epoxy paint.

Horizontal Array Section Test Data. - The following data represents the individual element test results obtained for finalized configurations. Consequently, the results presented represent the established requirements for which the production samples were later tested. This data is generally presented in one of two forms, tabular or graphic and in all instances the data is self explanatory. The following specific data is contained in this section:

- a. Insertion Phase Measurement/Comparison Test Set up (Figure 10)
- b. Insertion Phase Plot (after etching process) (Figure 11)
- c. Phase Error Plot (2nd aperture excitation at 9.3 GHz) (Figure 12)
- d. Phase Error Plot (2nd aperture excitation at 9.65 GHz) (Figure 13)
- e. Phase Error Plot (2nd aperture excitation at 10 GHz) (Figure 14)

- f. Amplitude Plot (1st aperture excitation at 9.65 GHz)  
(Figure 15)
- g. Amplitude Plot (2nd aperture excitation at 9.3 GHz)  
(Figure 16)
- h. Amplitude Plot (3rd aperture excitation at 10 GHz)  
(Figure 17)

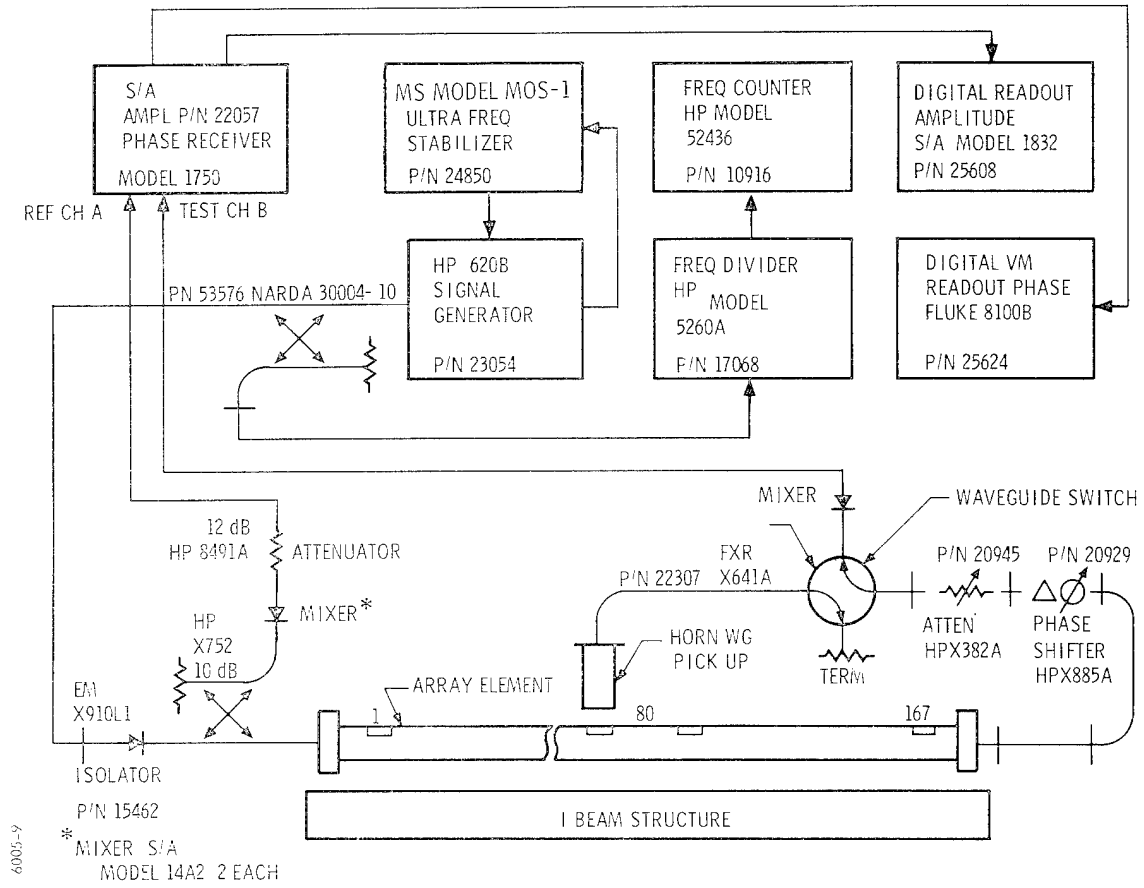
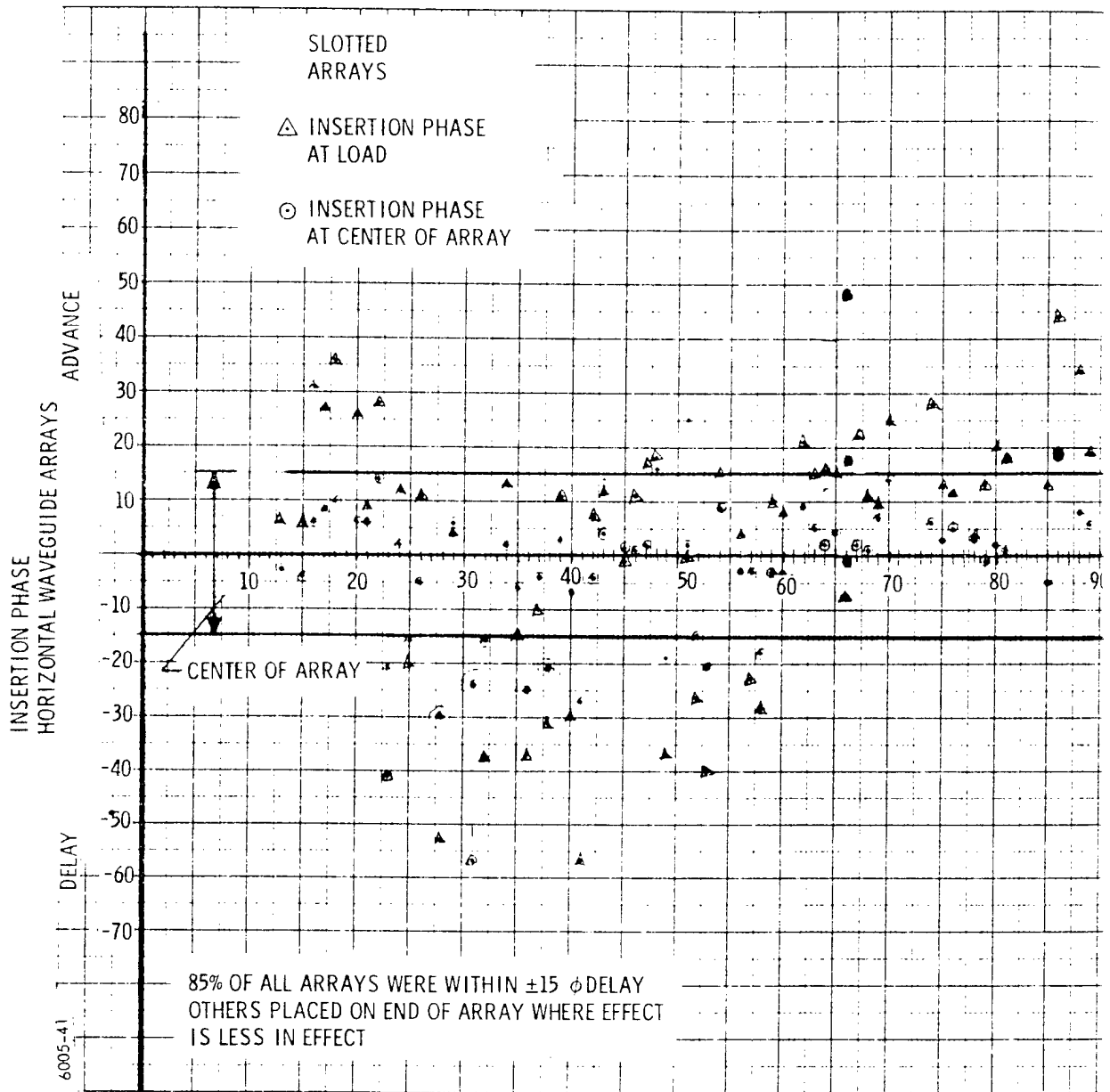

Figure 10. Insertion Phase Measurement/Comparison Test Setup



(1)

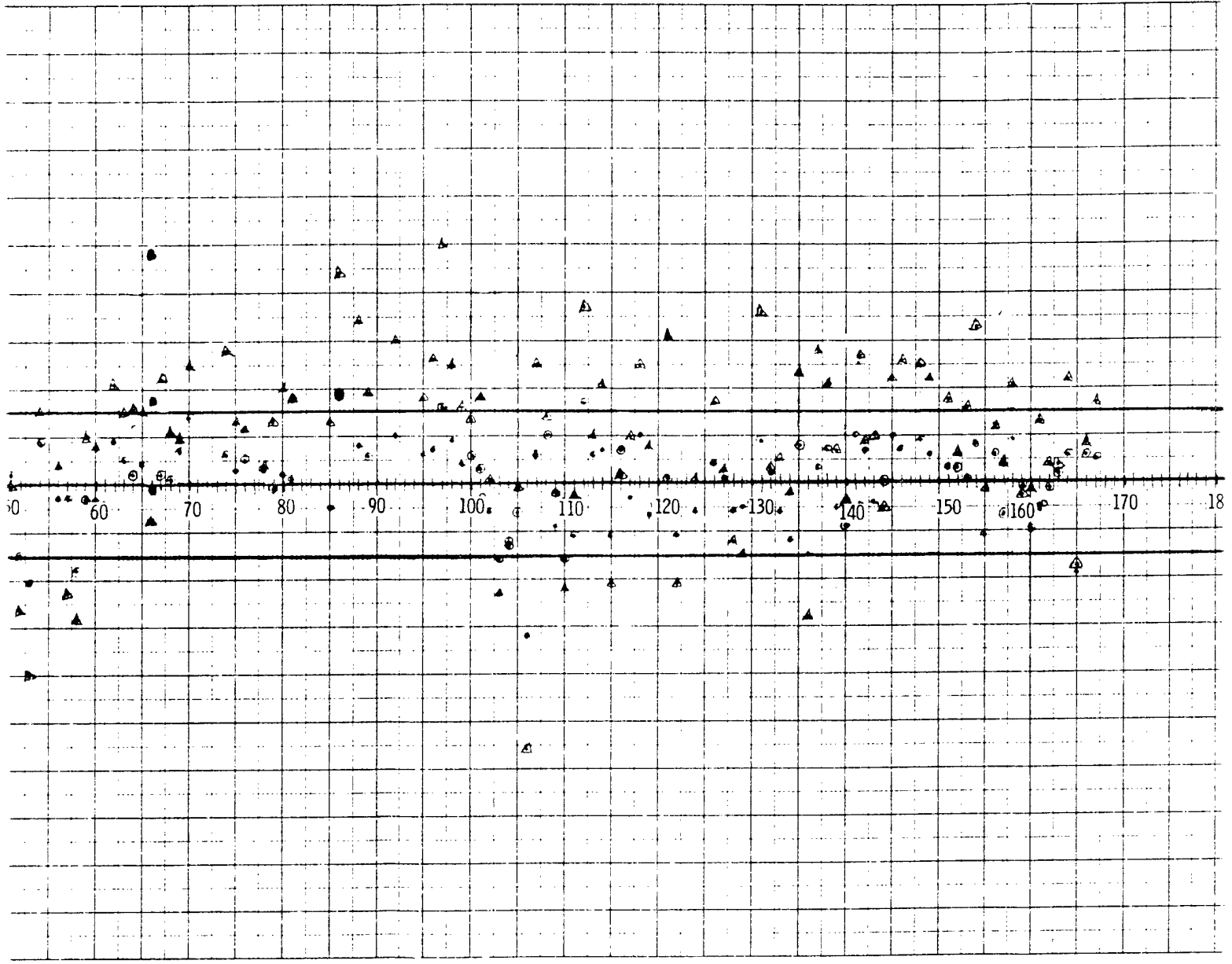
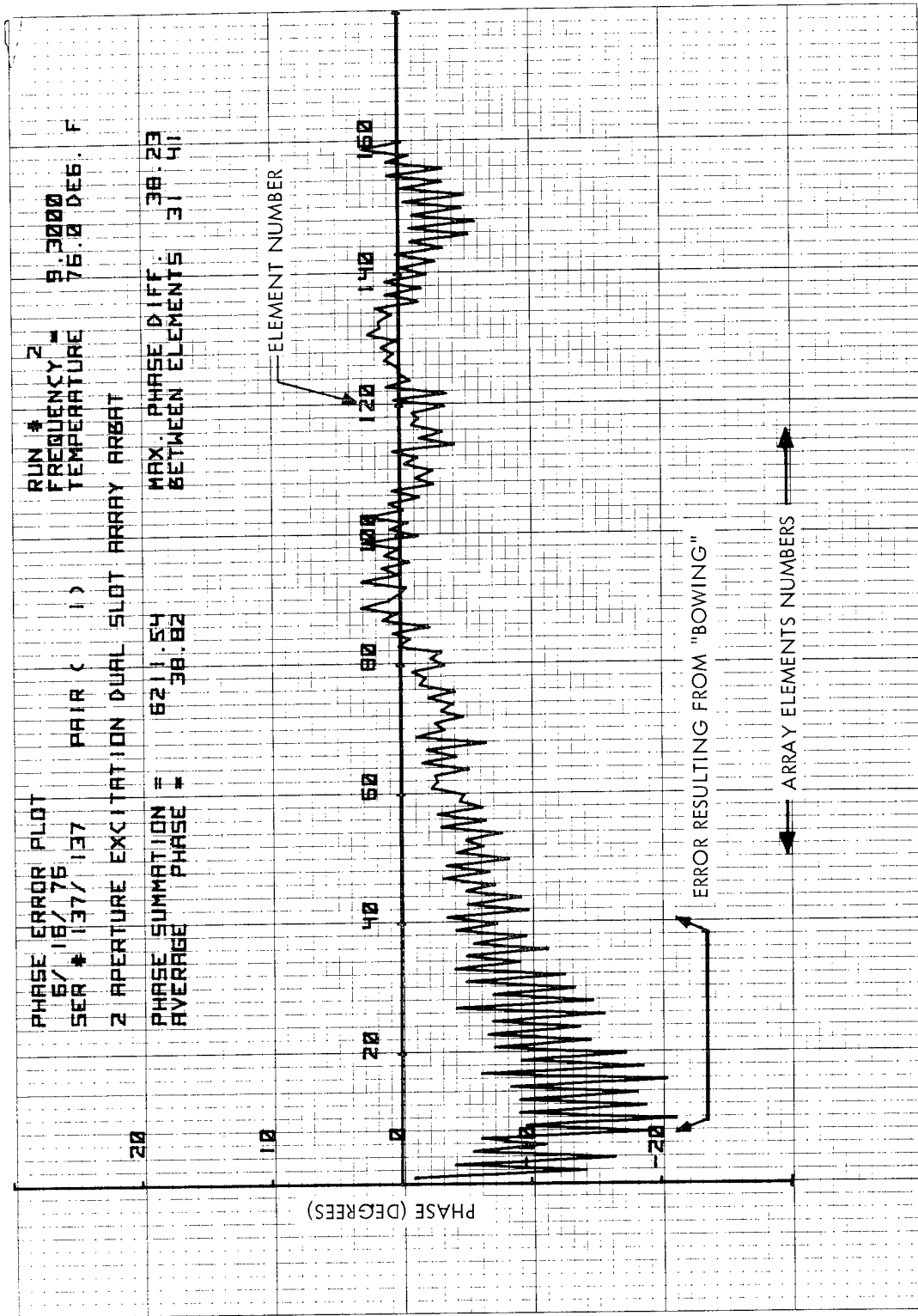

Figure 11. Insertion Phase Plot (After Etch)

67



6005-11

Figure 12. Phase Error Plot (2nd Aperture Excitation at 9.3 GHz)



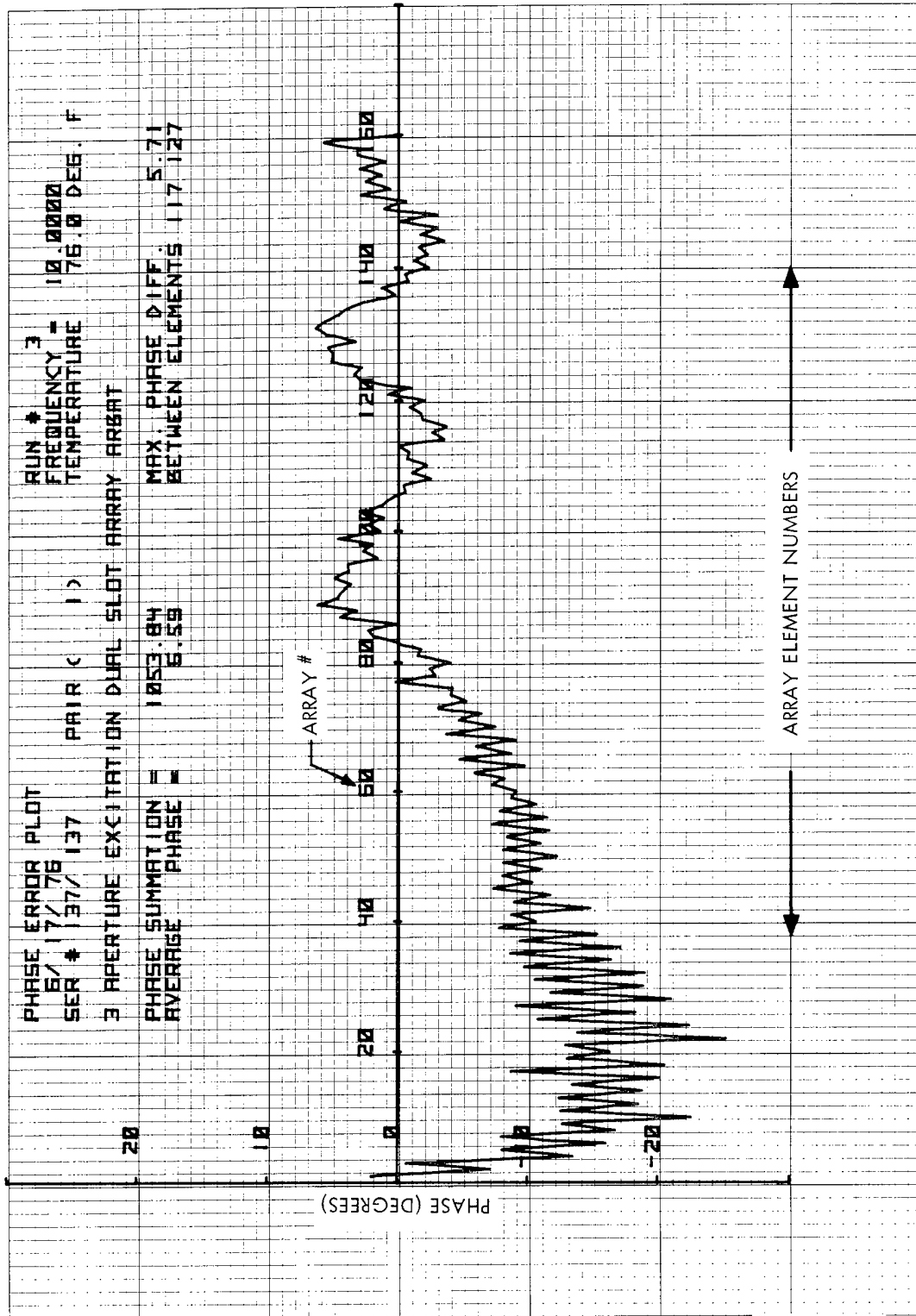

6005-13

Figure 14. Phase Error Plot (3rd Aperture Excitation at 10 GHz)

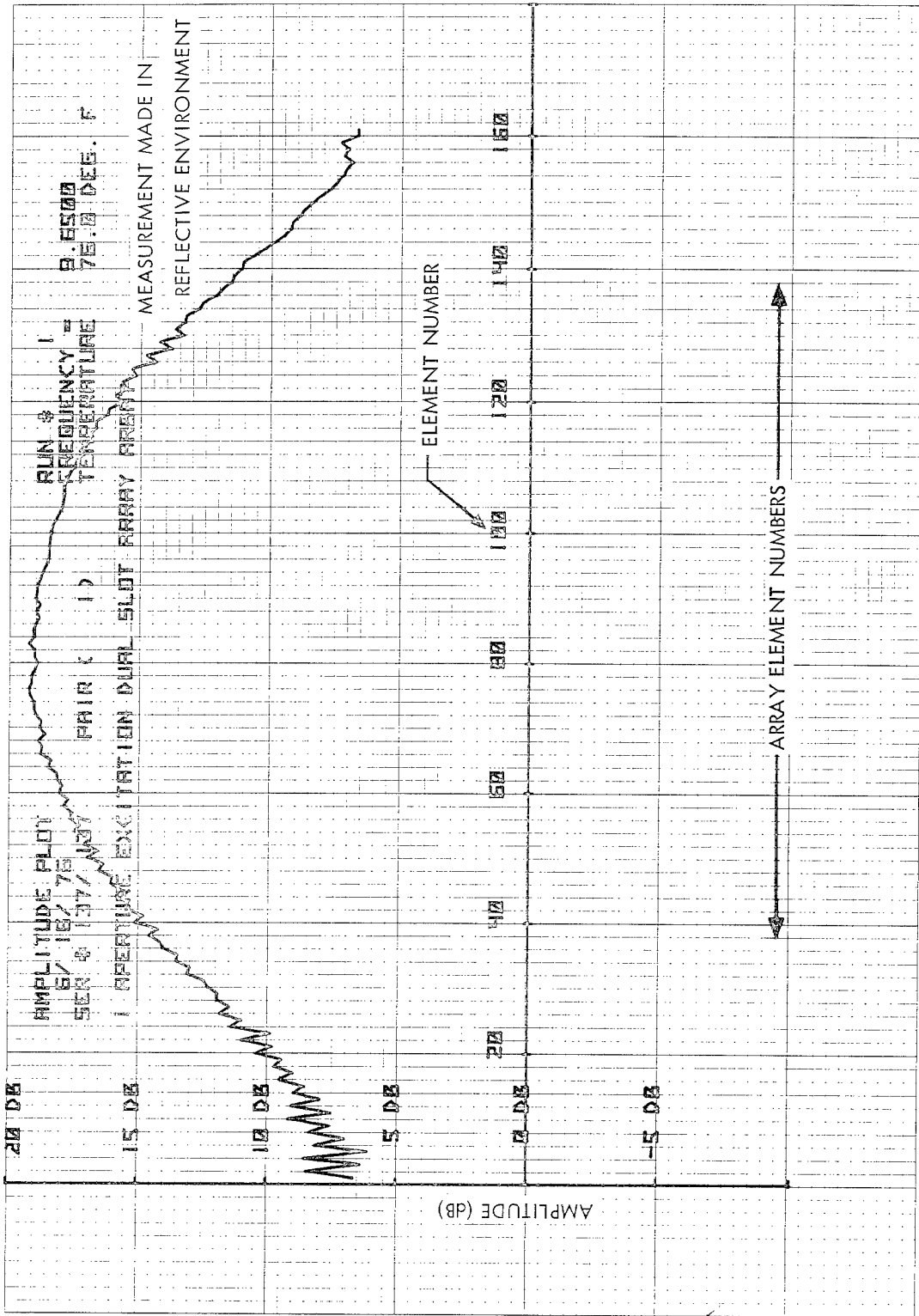

Figure 15. Amplitude Plot (1st Aperture Excitation at 9.65 GHz)

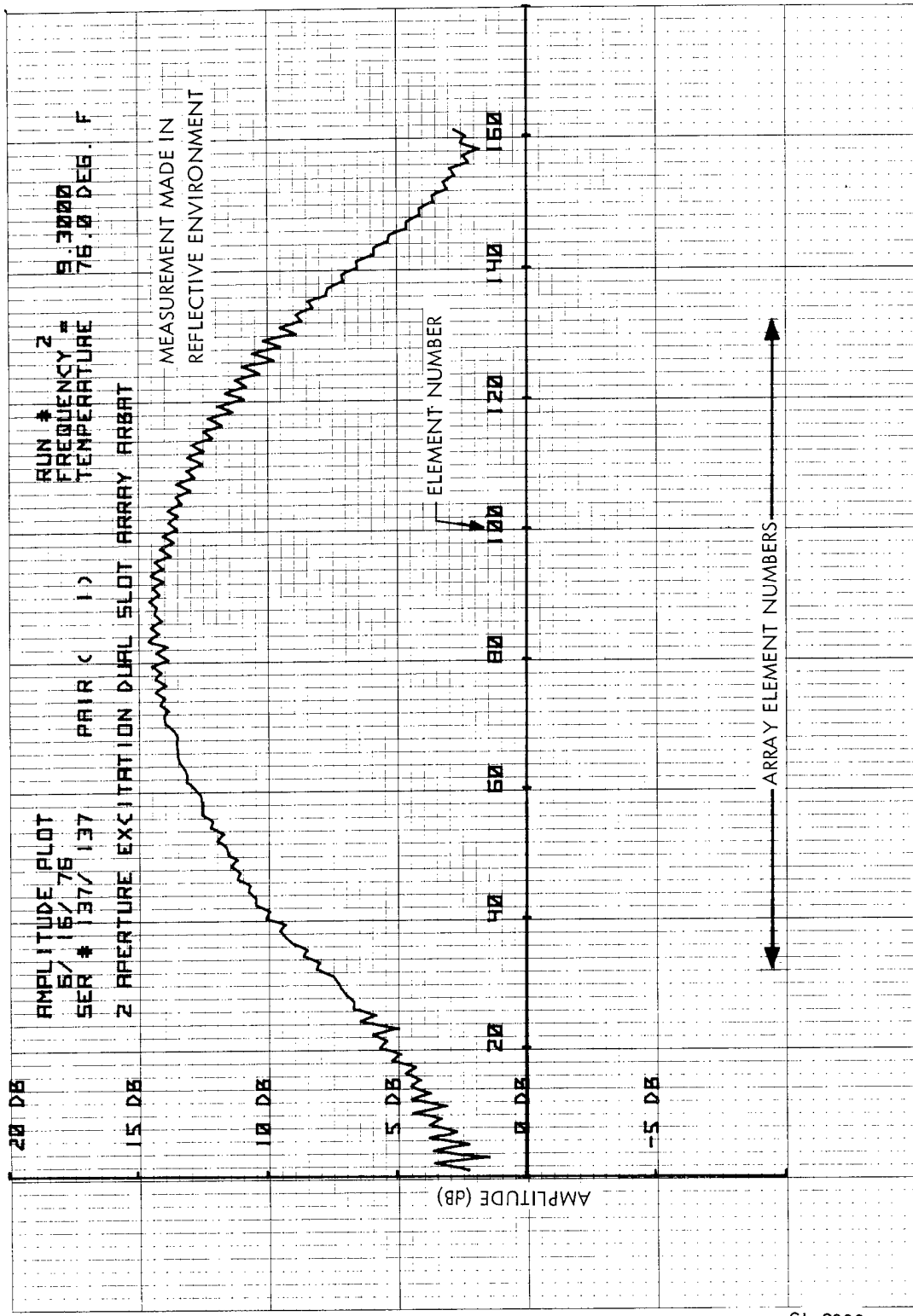

Figure 16. Amplitude Plot (2nd Aperture Excitation at 9.3 GHz)

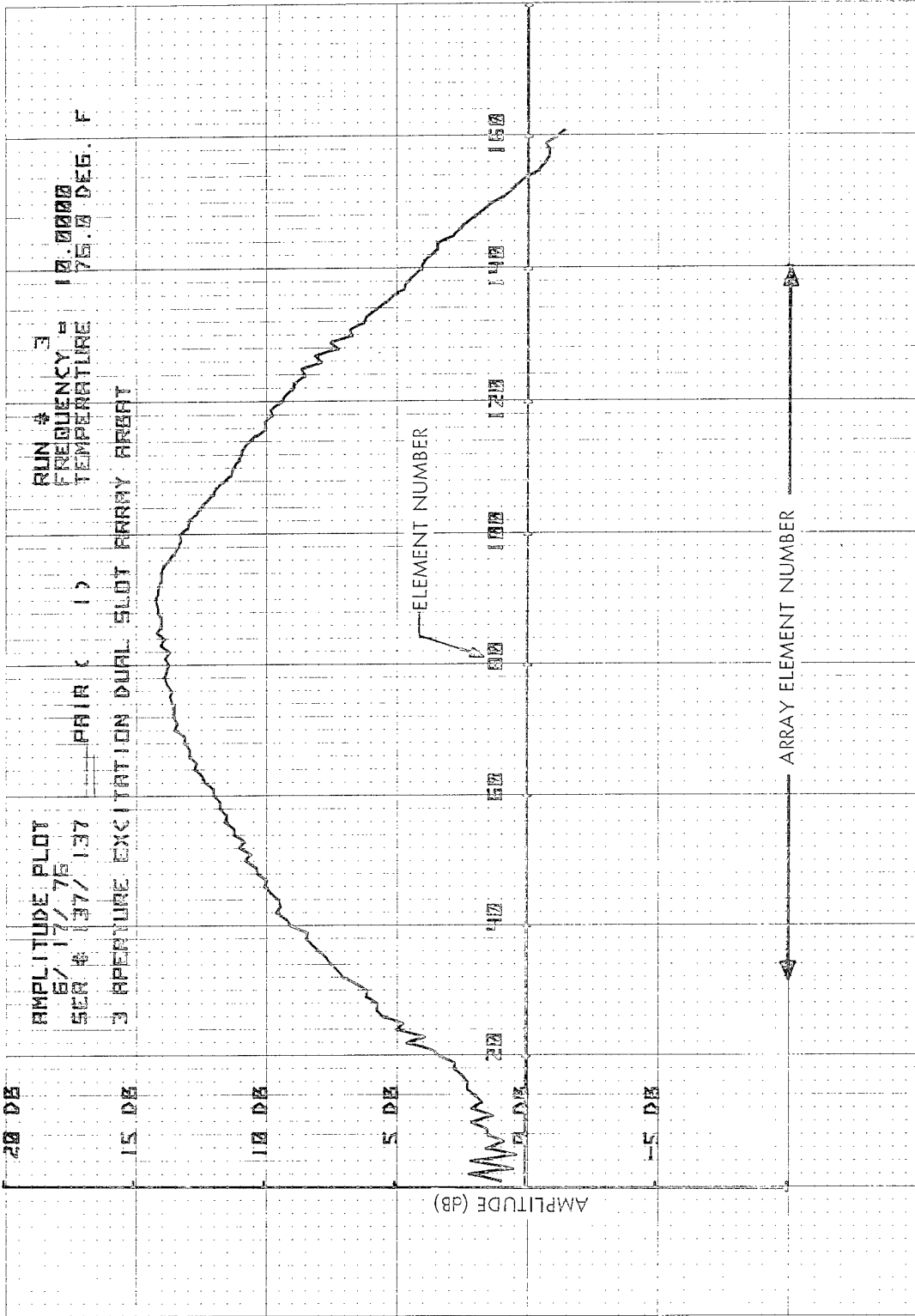

Figure 17. Amplitude Plot 3rd Aperture Excitation at 10 GHz)

### 2.3 Vertical Feed Line

The vertical feed line provides the single RF connection between the transmitter/receiver and the antenna. The RF input/output connection is at the lower end of the vertical feed waveguide section. Connection to the feed line is made with a short section of flexible waveguide. The vertical feed distributes the input to individual horizontal arrays by way of four-port coupling apertures into 90 degree twist sections that distribute energy to and from the 167 horizontal array sections via the diode phase shifters. The 90 degree twist sections are attached to the vertical feed line by dip brazing. The feed line and its position in the antenna assembly are shown in the photograph, Figure 18.

Vertical Feed Line Configuration. - The feed line is 120.52 inches long and is fabricated in three separate sections from precision waveguide (aluminum) per MIL-W-85/1. Waveguide dimensions are 0.400 x 0.900 inside by 0.500 x 1.00 inch outside. See drawing 140307 for design details (available at Picatinny Arsenal).

Vertical Feed Tests. - After finalization of design detail, tests to determine actual insertion loss and VSWR were run. The results of the tests are shown graphically in Figure 19 Insertion Loss, Figure 20 VSWR (Elements 113 to 167), and Figure 21 VSWR (Expanded Figure 20).

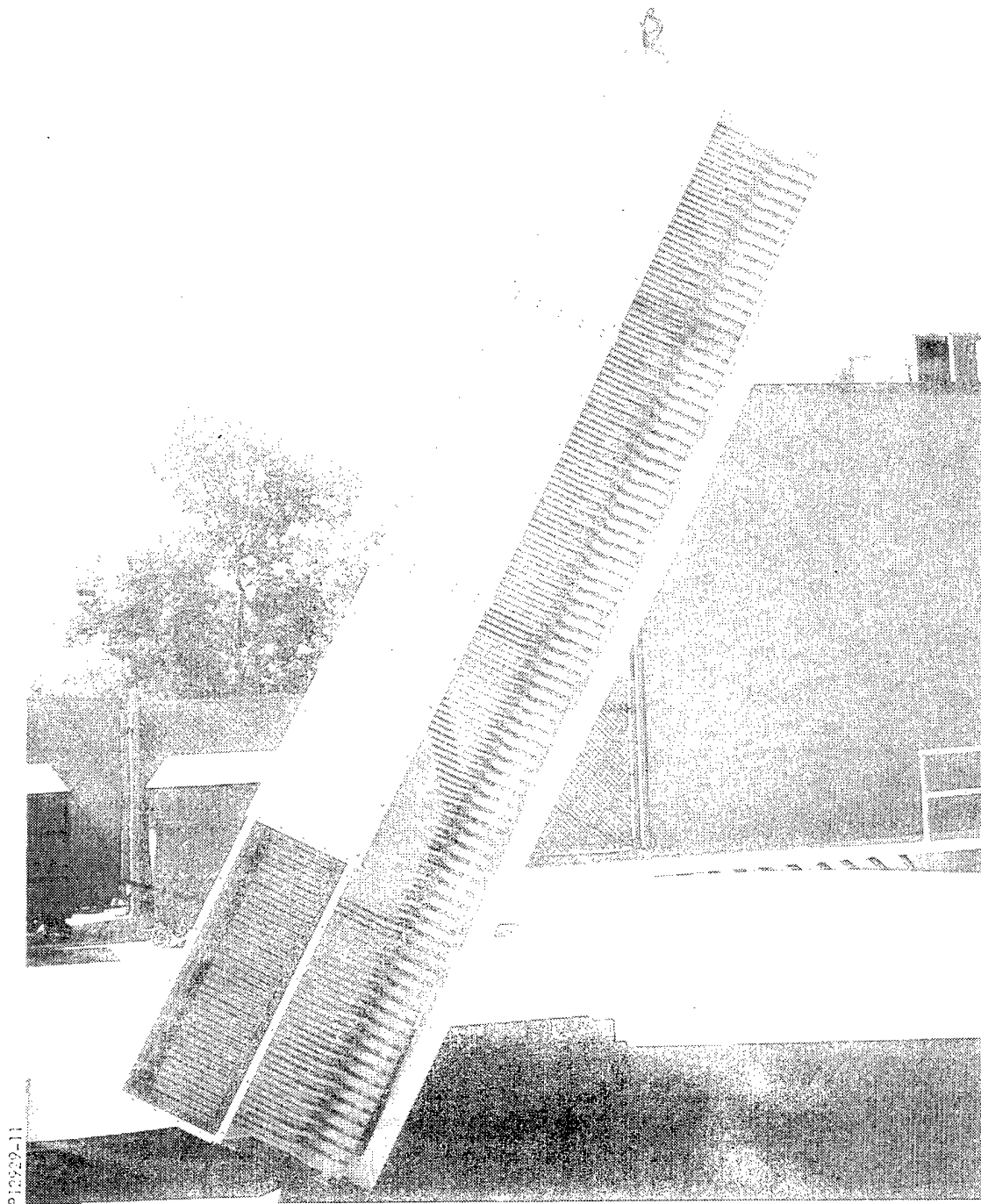

Figure 18. Vertical Line Feed in Assembled Antenna

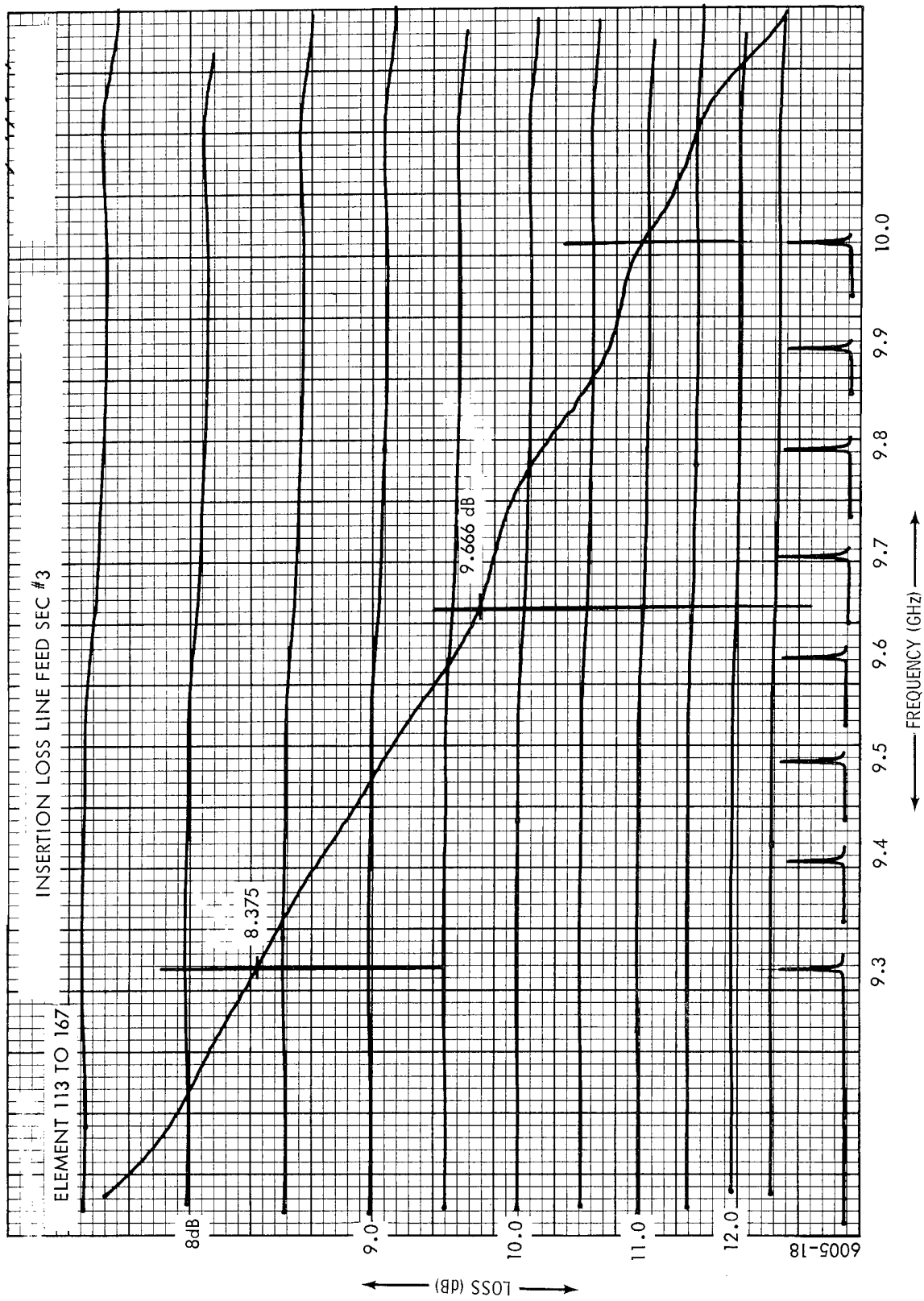

Figure 19. Vertical Line Feed Insertion Loss vs Frequency

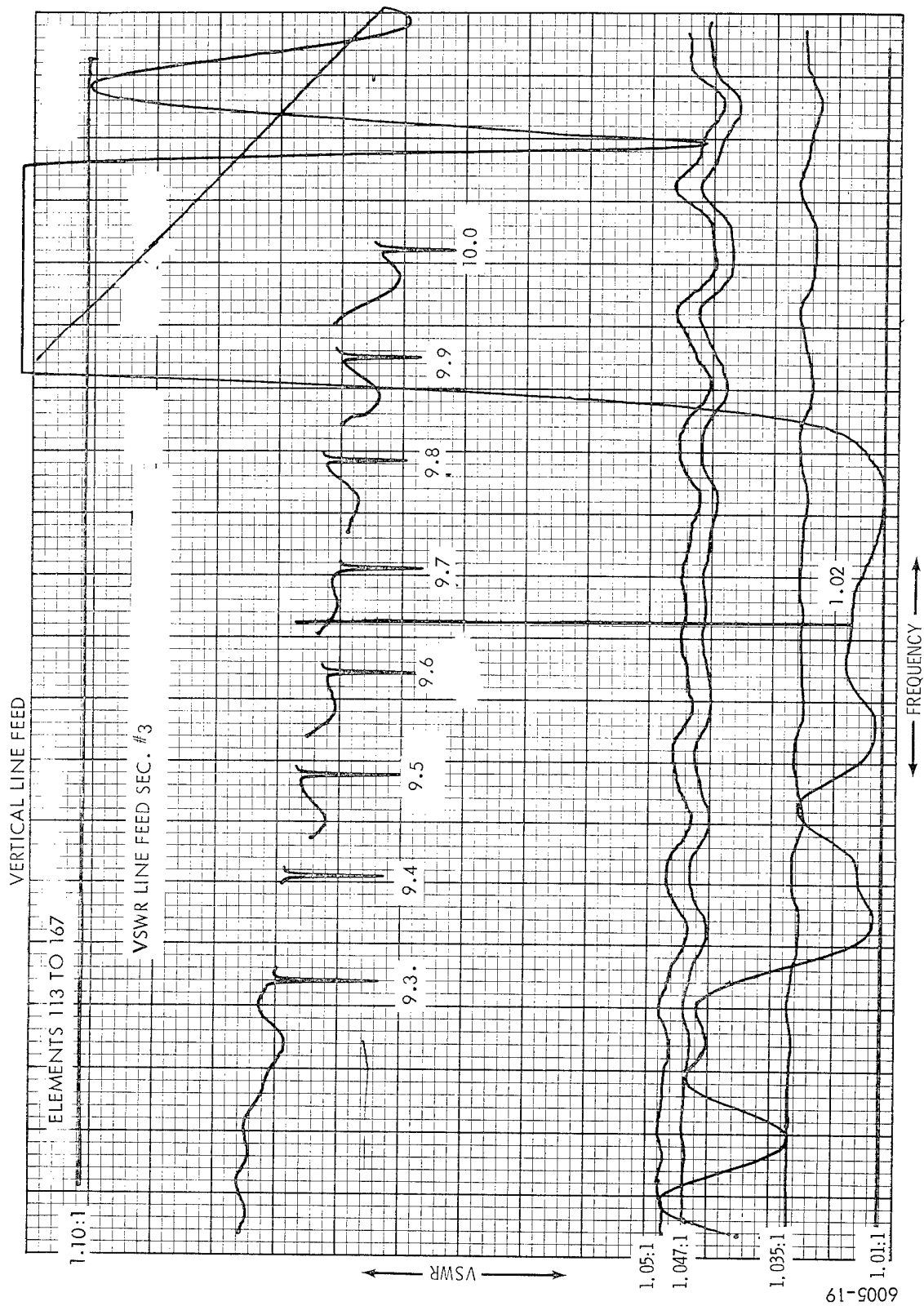

Figure 20. VSWR vs Frequency: Line Feed Section #3

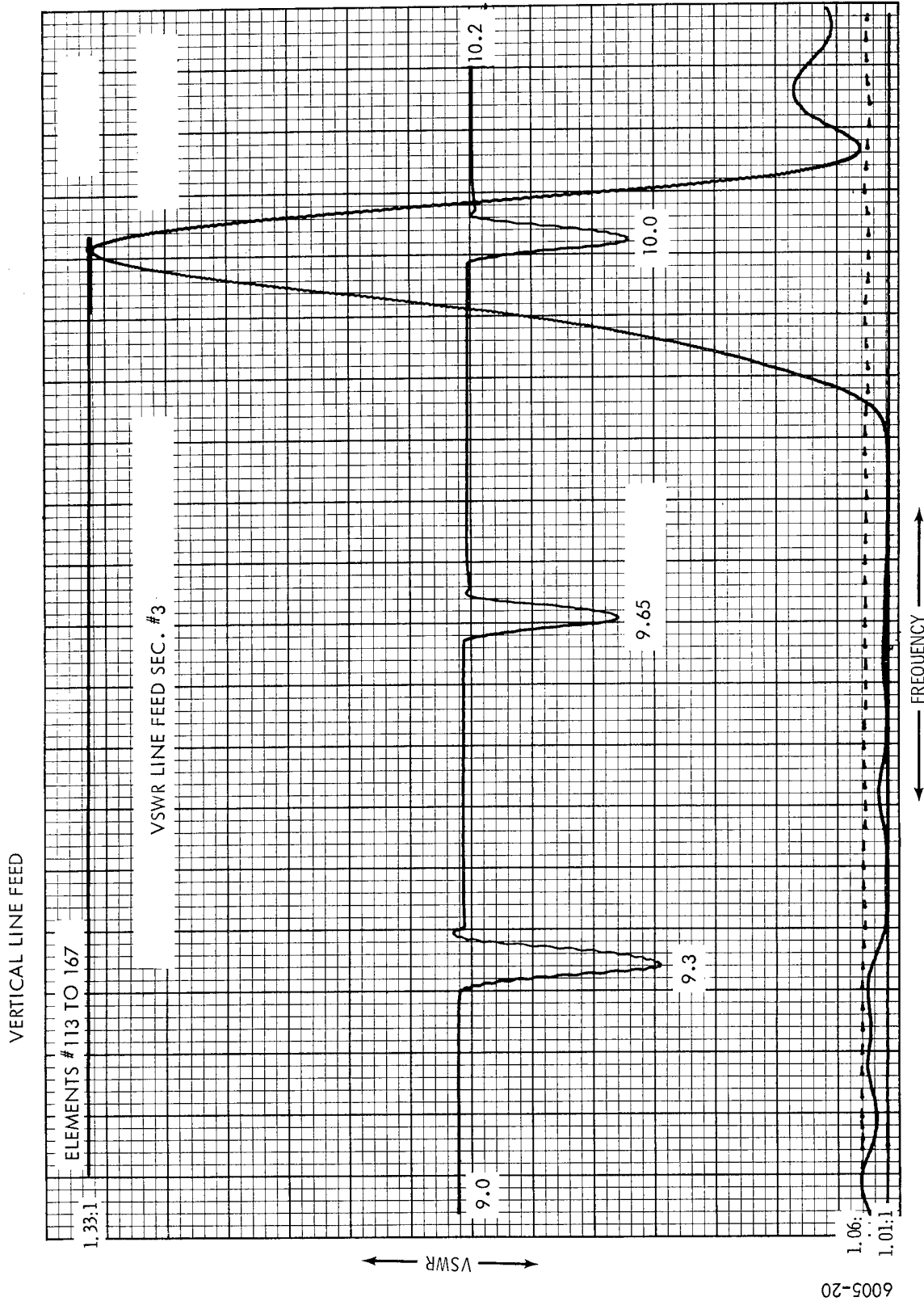

Figure 21. VSWR vs Frequency: Line Feed Section #3 (Expanded Scale)

#### 2.4 90 Degree Twist Crossguide Coupler Section

Horizontal array sections are coupled to the vertical feed line (via diode phase shifters) by a  $90^\circ$  twist waveguide section with four port coupling apertures. A loading block is inserted in the closed end of each coupler section opposite the feed line. Four port coupling slots match apertures in the vertical feed line. Attachment of coupling sections to the feed line is by dip brazing. The physical configuration of the production section is shown in the photograph, Figure 22.

Physical Configuration. - The crosscouplers are fabricated from precision waveguide (6061-F aluminum alloy in accordance with MIL-W-85/1). Figure 23 illustrates the configuration of the part. (See drawing 140311 for dimensions, available at Picatinny Arsenal.)

Coupler Testing. - Testing this element was relatively simple because of its configuration and previous tests for terminating loads and coupling slot dimensions. VSWR tests were conducted on a sample quantity of coupling sections with results shown in Figure 24.

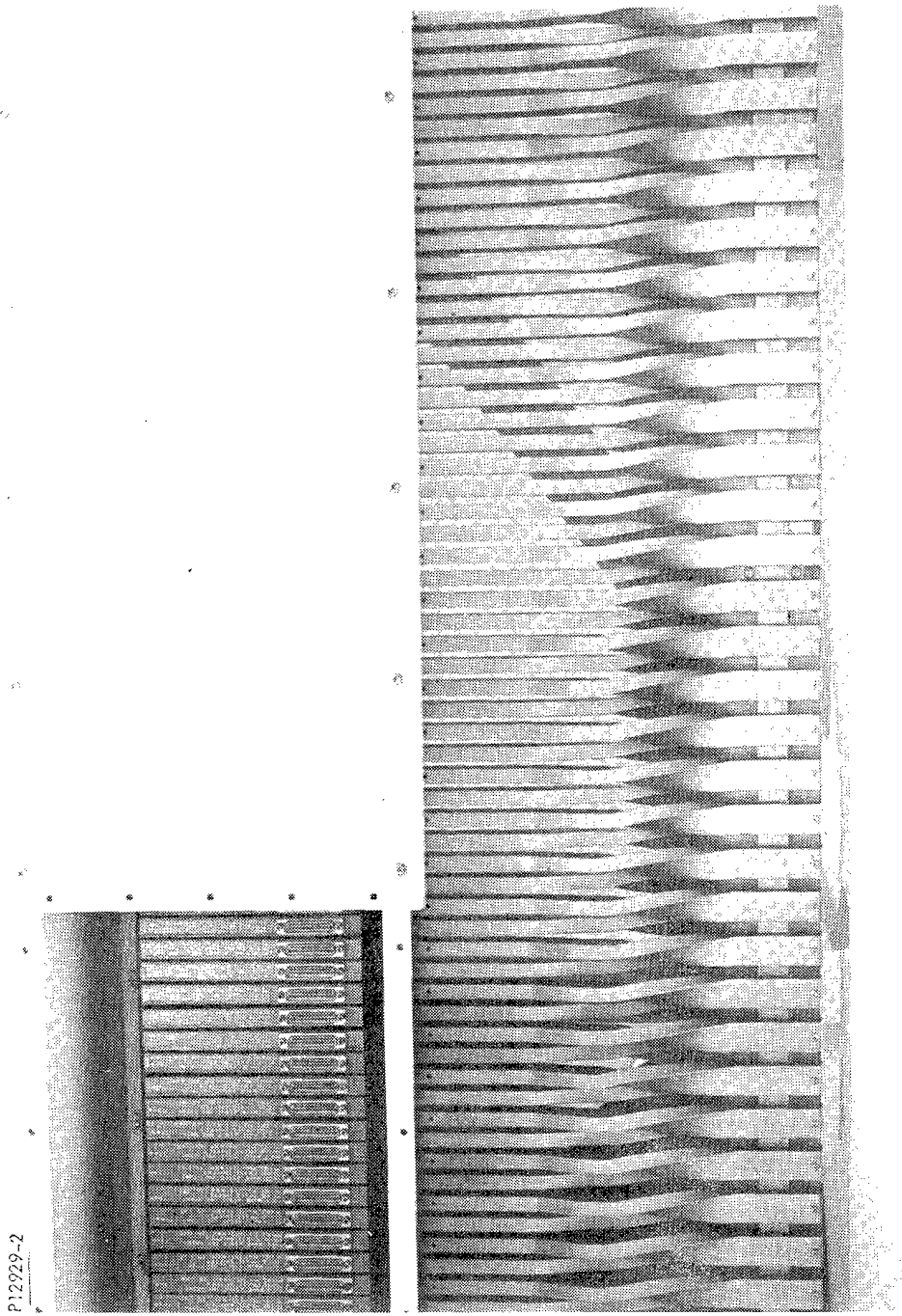

Figure 22. Ninety Degree Twist Crossguide Coupler  
in Assembled Antenna

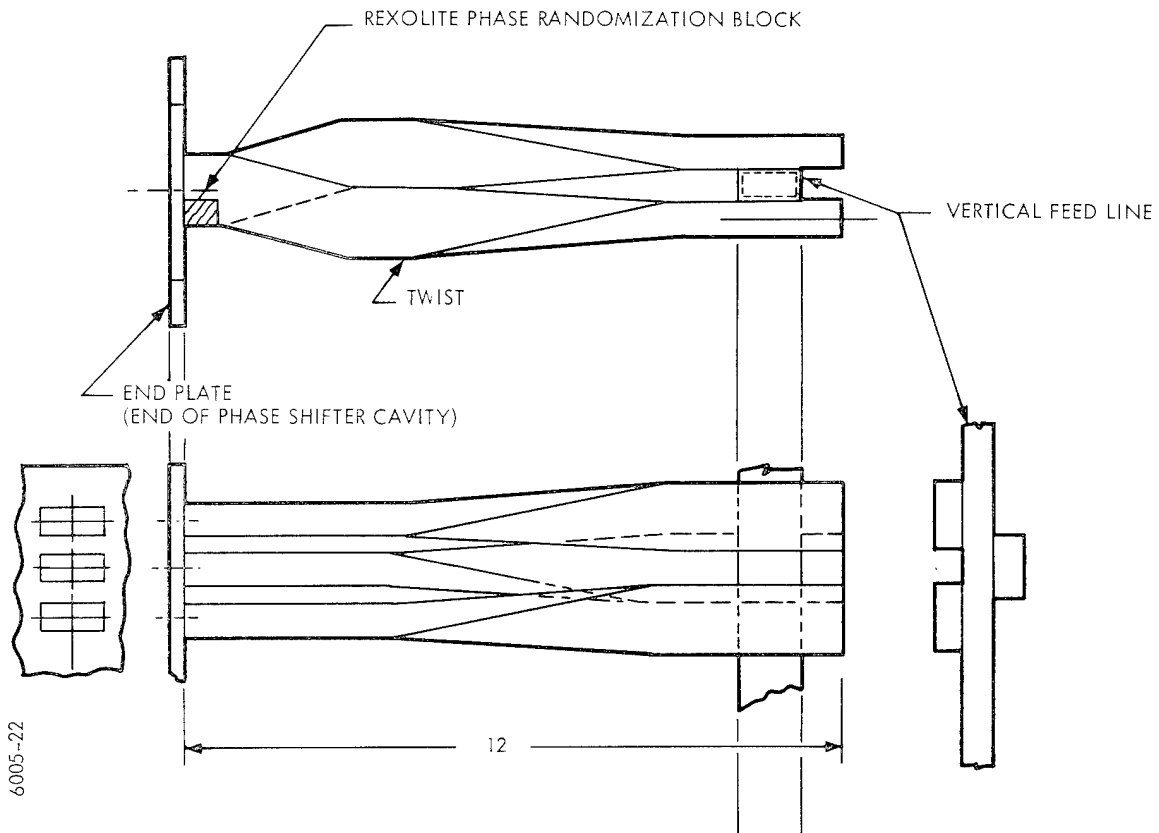

Figure 23. Ninety Degree Twist Crossguide Section

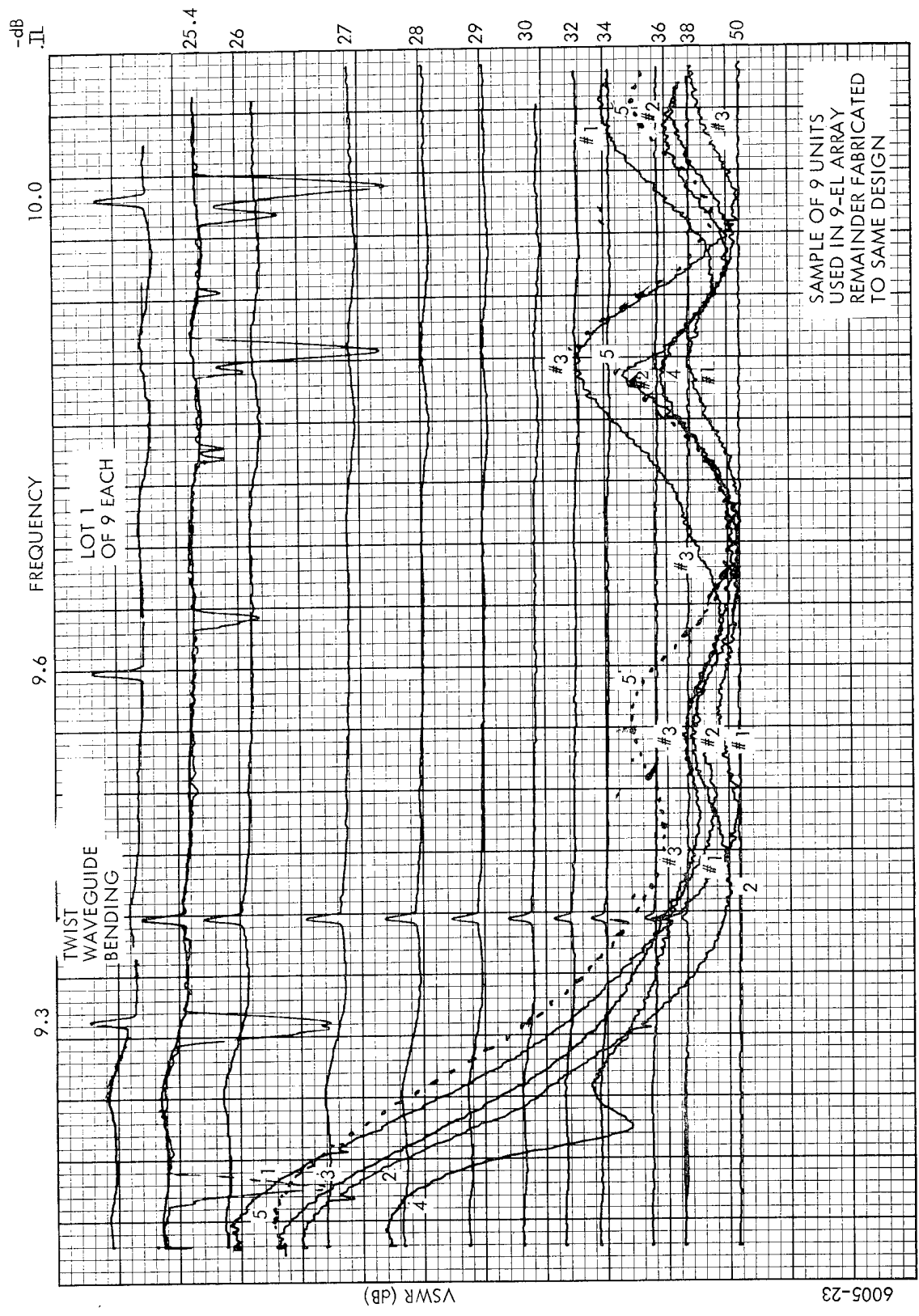

Figure 24. Ninety Degree Twist Section VSWR Plot

2.4.1 Load: Termination (Vertical Feed Coupler). - Equalizing termination loads are required for each coupler section at the vertical feed line. The loads used in the ARBAT antenna are fabricated from ECCOSORB 17 Compound, which is molded and then machined to final dimensions. The load element is then cemented to a waveguide cap plug and the assembly is installed in the ends of each coupling section. The load element is drilled for a 4-40 screw which further secures the load/plug assembly in the coupling section. All load elements in the 167 couplers are of uniform dimensions.

Load Test. - Sample loads were tested over the operating frequency range to insure acceptable return loss values. The VSWR values obtained from the finalized design are shown in Figure 25. For detailed design including dimensions see Drawing 140313 (available at Picatinny Arsenal).

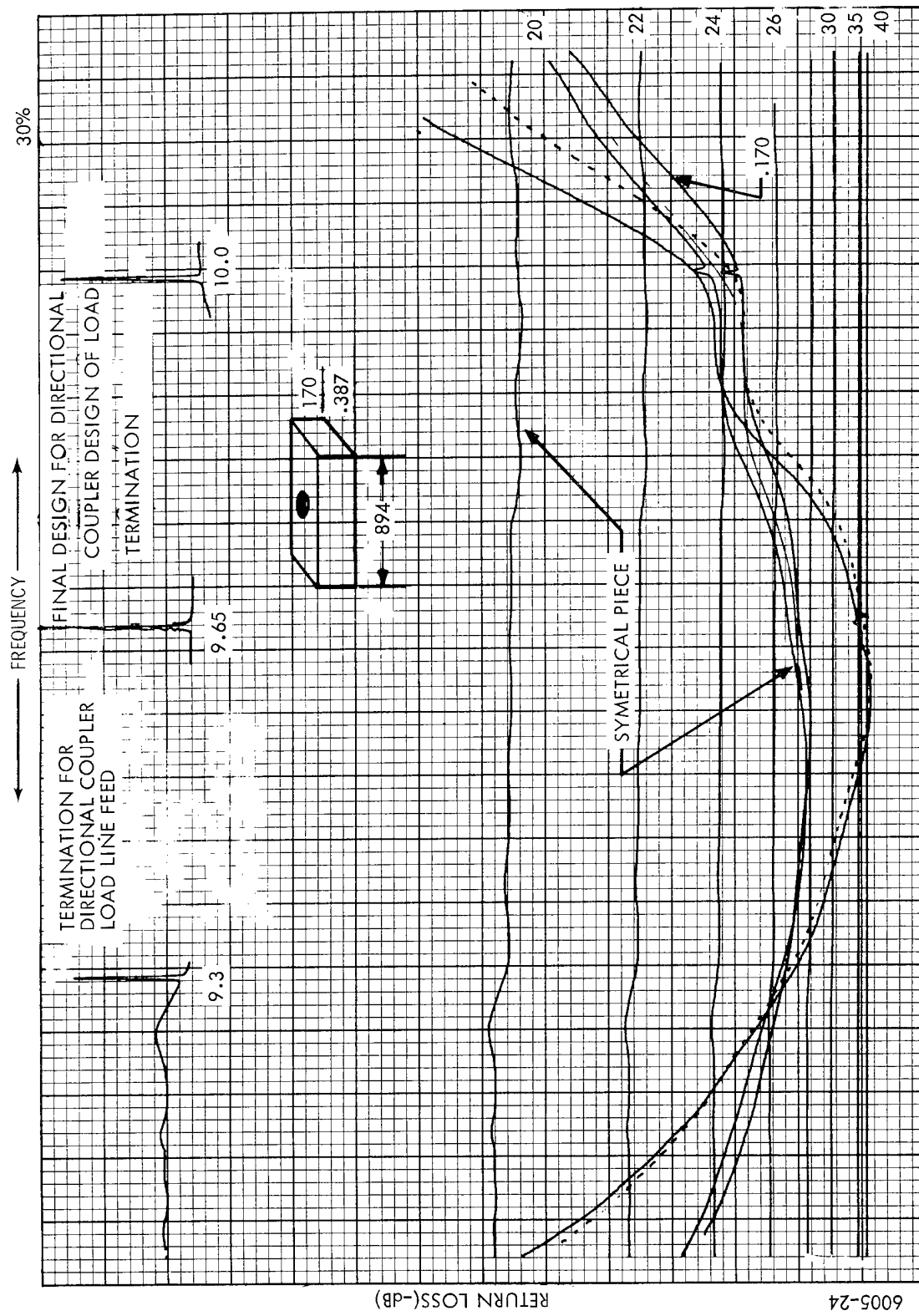

Figure 25. Load: Vertical Feed Coupler VSWR Plot

2.4.2 Phase Randomization Blocks. - Phase randomization blocks are used in the beam scanning path to reduce the degree of phase quantization effect which may occur with digital phase shifters producing relatively large phase shift increments.

The method of overcoming the possible occurrence of phase quantization effects in the ARBAT antenna is through the installation of a dielectric material block in each 90 degree twist section. The blocks are fabricated from Rexolite material in a single width ( $\frac{.390}{.400}$  inch) and six lengths (0.216; 0.207; 0.170; 0.709; 0.722; and 0.769 inch). The phase randomization blocks are installed in the narrow dimensions of each twist section at the end adjacent to the phase shifter. Each block is held in place by a single screw and epoxy adhesive. The position of the block in the 90 degree twist section is shown in Figure 26. The configuration and dimensions for the series of blocks is shown in Figure 27.

Phase Randomization Block Tests. - The parameters of significance in the phase randomization block design are insertion phase over the radar bandwidth and return loss over the operating frequency range. The results of tests using samples of each block configuration are shown in Figure 28, Phase Randomization Block Insertion Phase vs Frequency and Figure 29, Phase Randomization Block Return Loss vs Frequency

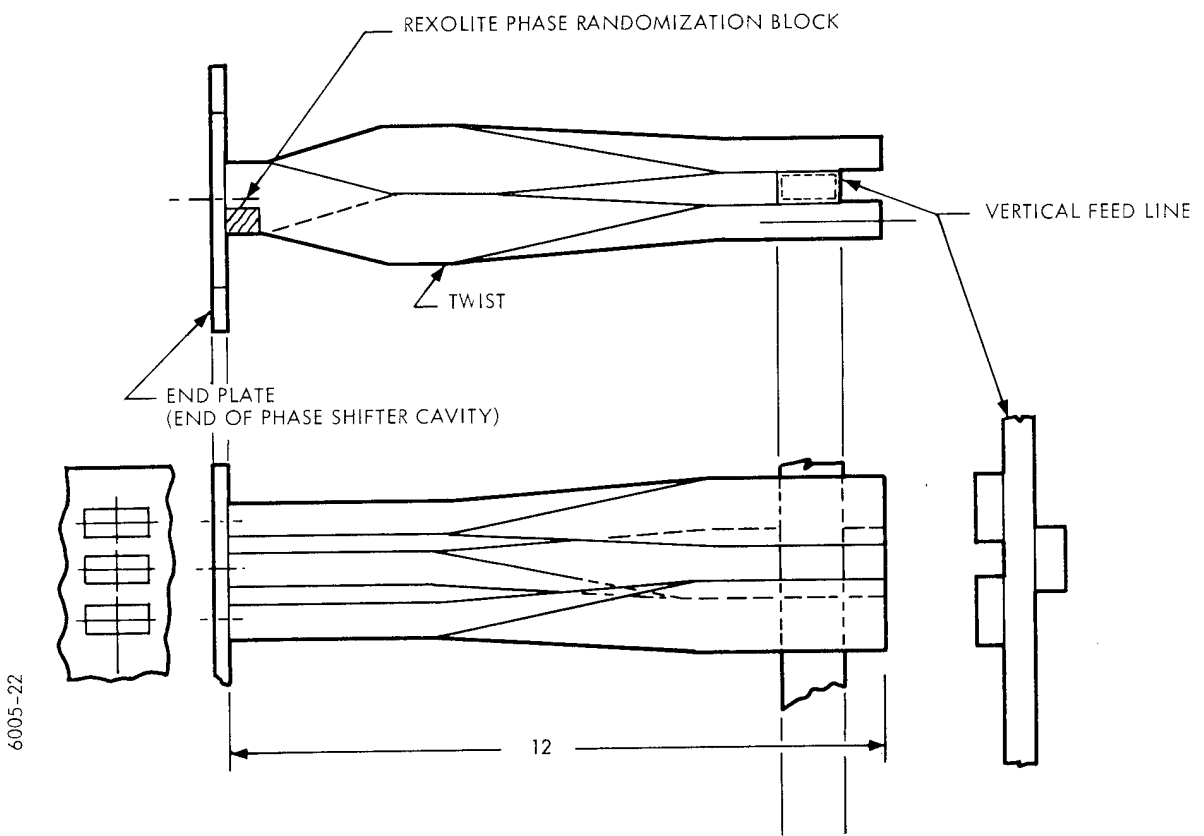
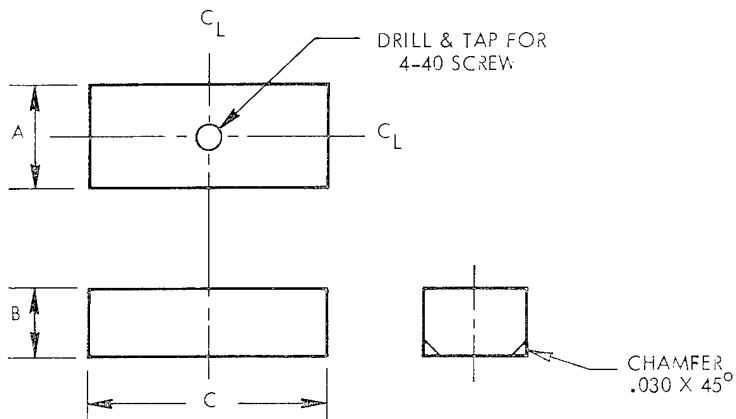

Figure 26. Phase Randomization Block Location in Coupler



MATERIAL  
 REXOLITE  
 DIELECTRIC MATERIAL  
 $E = 2.54$   
 $f_0 = 9.65 \text{ GHz}$   
 $\alpha = 0.900$

DASH	A	B	C	
-1	$\frac{.390}{.400}$	.216	.709	BLK
-2	$\frac{.390}{.400}$	.207	.722	BLUE
-3	$\frac{.390}{.400}$	.170	.769	GR

6005-25

Figure 27. Phase Randomization Block Series

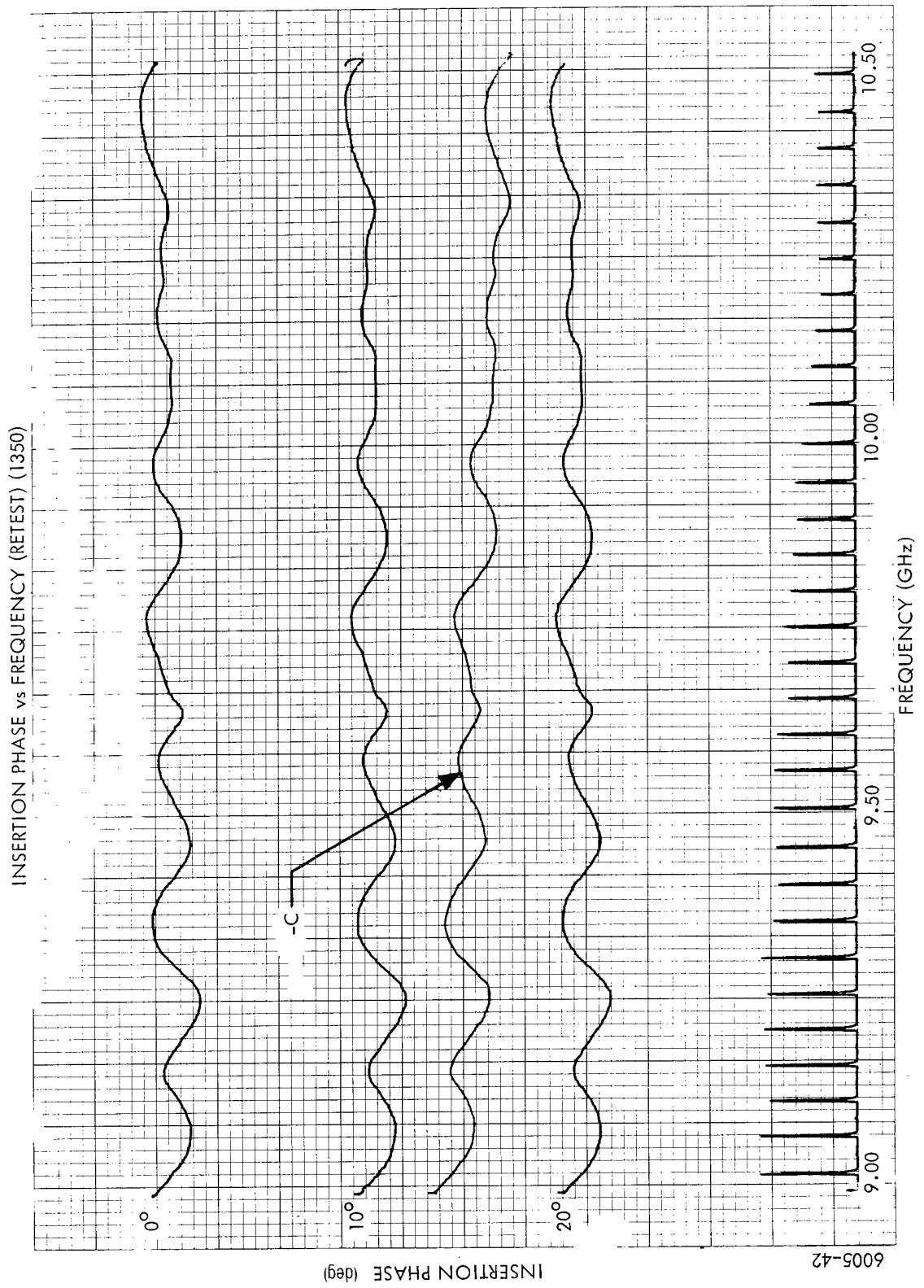
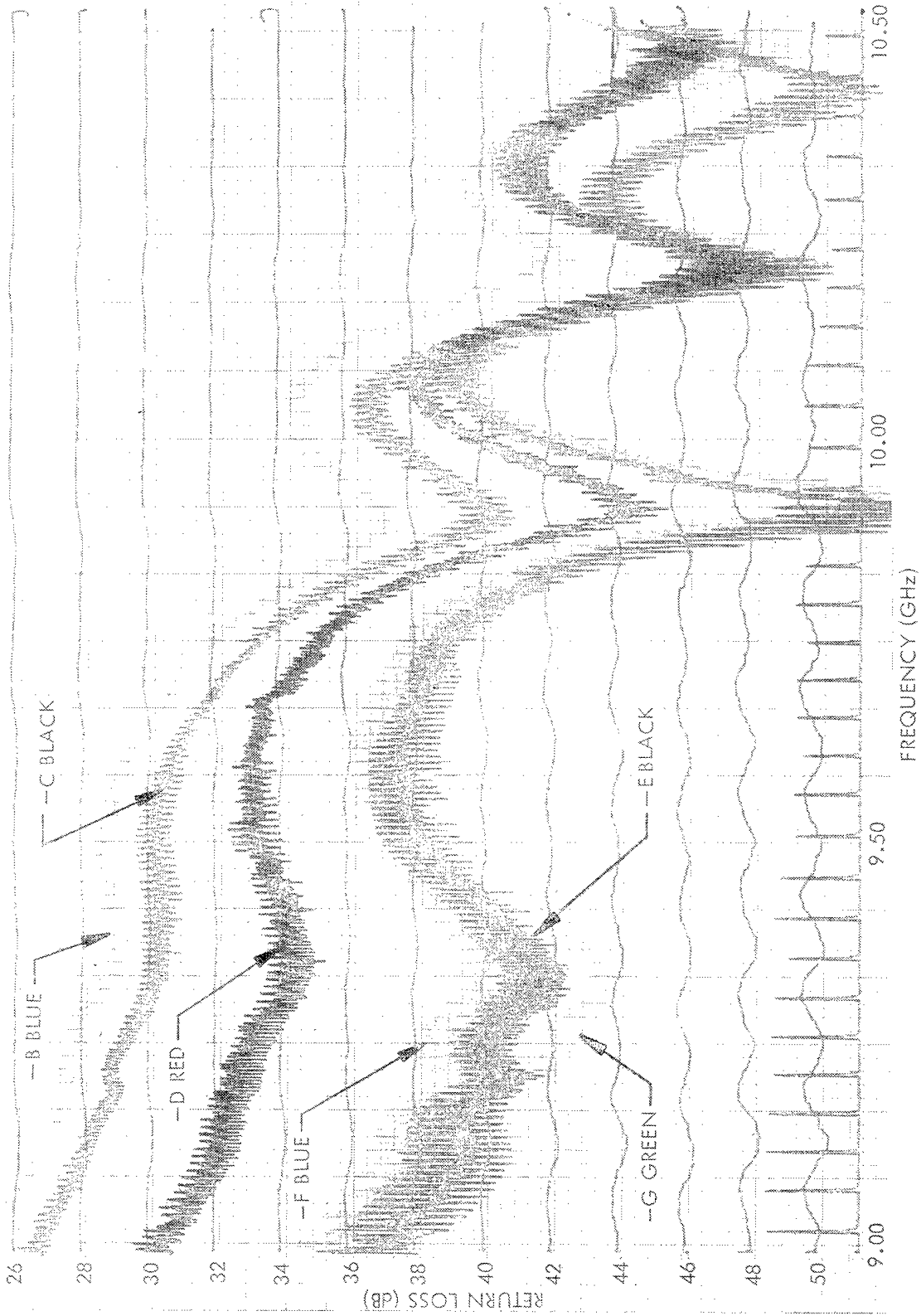

Figure 28. Phase Randomization Block

RETURN LOSS vs FREQUENCY (RETEST) (1030)



6005-49

05

Figure 29. Phase Randomization Block

## 2.5 Diode Phase Shifter

The ARBAT antenna uses digitally controlled diode phase shifters to phase the energy radiated by the horizontal array elements in accordance with computer/software controlled logic. Phase shifter control in the ARBAT antenna permits control of the pencil beam over the range of  $\pm 35$  degrees in elevation with respect to beam normal. The ARBAT antenna requires 167 phase shifters which have been supplied as Government Furnished Equipment.

The reciprocal phase shifters provide four-bit phase control over the range of 9300 to 10,000 MHz. A total of 16 phase states may be set by the logic control resulting in a phase state range of 0 to 337.5 degrees in 22.5 degree increments.

The phase shifter unit package includes a driver circuit and space for a logic decoding package. The input to each phase shifter package comes from a beam steering buffer unit. The control logic for the array (167 phase shifters) functions in a serial mode and, the decoding process is similar to signal progression through a long shift register. Each phase shifter contains two four-bit shift registers as shown in the block diagram of Figure 30. The four-bit command is clocked into the first register of phase shifter number 1 on the first shift command. A load signal transfers the four-bit command to the second register whose outputs drive the phase shifter assembly. A second shift command transfers the four-bit command to the first register of the second phase shifter where it is loaded by a load command.

The sequence described above is repeated from phase shifter to phase shifter with each decode logic assembly receiving data from the previous one (along with the bussed control commands). The output of the 167th logic assembly is fed back to the beam steering buffer for integrity verification.

The sampled output of each driver is then amplified and sent to built-in test equipment and compared to the phase-set command. A determination is made as to whether the phase shifter is receiving the correct command, and incorrect command, or if commands are reaching the unit.

The output voltages of the driver power supplies are also monitored. The outputs are compared with a predetermined reference voltage from a voltage regulator. If the output voltages vary by more than  $\pm 5$  percent, an

"abnormal" condition is indicated. Phase shifter logic control organization is illustrated in Figure 30. Phase shifter position in relationship to the 90 degree twist waveguide section is shown in the assembled antenna in the photograph, Figure 31.

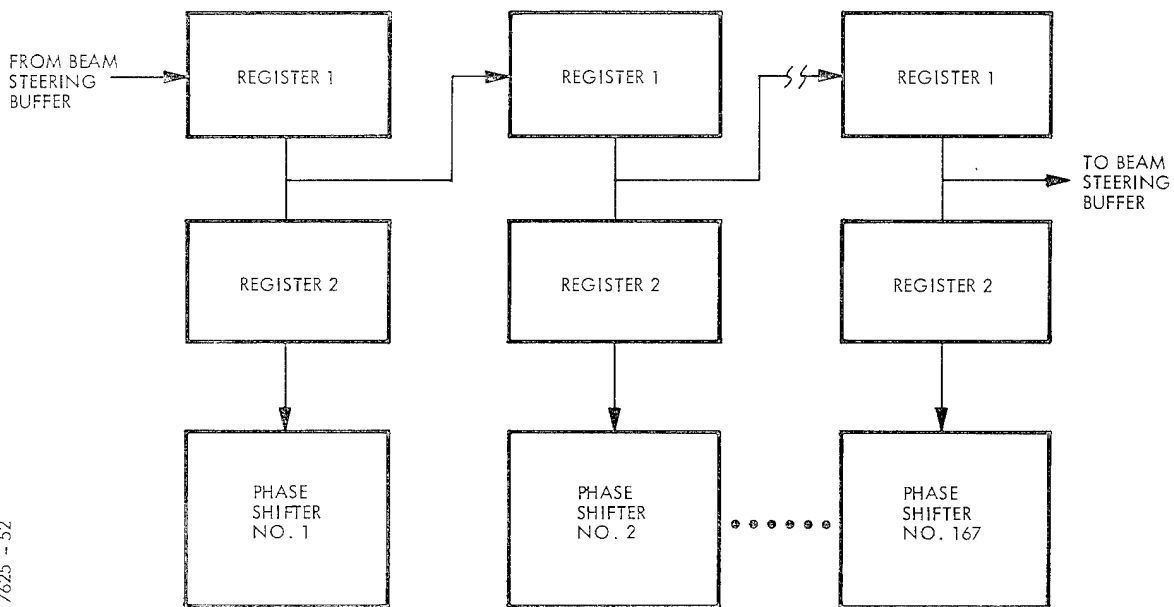

7625 - 52

Figure 30. Phase Shifter Decode Logic Organization

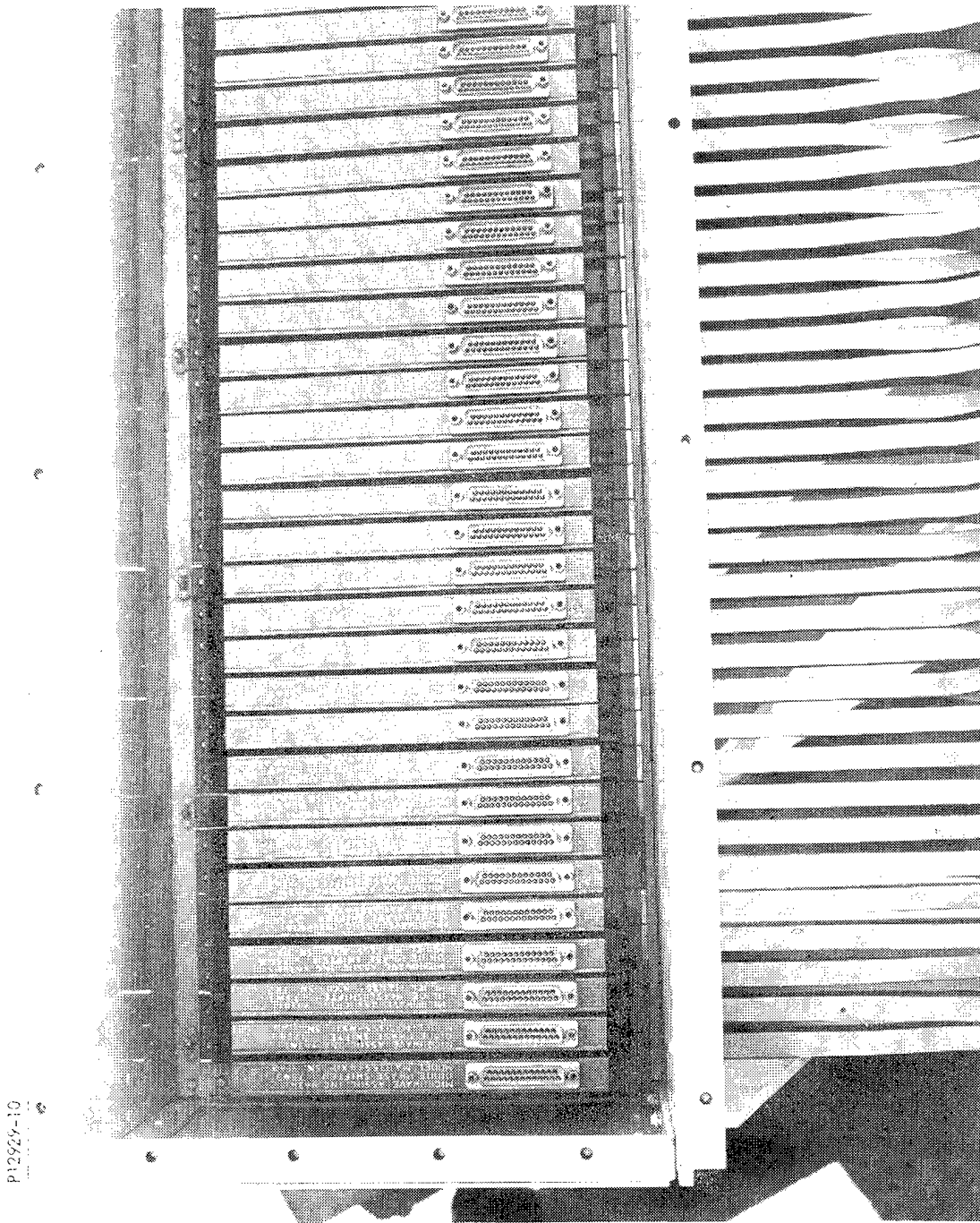

Figure 31. Phase Shifter Position in Assembled Antenna

## 2.6 ARBAT Antenna Performance Monitor Concept

The purpose of the performance monitoring features incorporated into the ARBAT antenna design is to provide a dynamic checking capability on the operability and performance of the overall antenna subsystem. In addition to the latter basic function, the monitor capability facilitates the location of defective components or components operating in a degraded mode.

The performance monitoring function in the ARBAT antenna is accomplished by the inclusion of the performance monitor line and monitor line couplers described in the following section (2.6.1). The additional components required to monitor the signal detected at the output of the vertical monitor line are not parts of the antenna and are not described in this report.

In operation, overall general antenna performance may be ascertained by observing the pattern presentation on a monitor display. If the observed display is abnormal indicating degraded performance, a special diagnostic routine generated by the CPU may be initiated which supplies logic commands to the phase shifter control circuitry. By means of these diagnostic commands, the cause of the abnormal display may be localized to the individual horizontal array element and/or phase shifter in the individual array section that is responsible for the indication.

The sketches in Figure 32 (Performance Monitoring Concept) illustrate the fault detection process.

Point A of the antenna fault detection approach schematic is the location of a single ended mixer. At this point, a signal from a good antenna would be similar to the second illustration when the phase shifters are programmed through a standard scan. If the antenna has component failures affecting the elevation pattern, overall system performance will be degraded, and the sidelobe pattern will be distorted as in the third figure.

To localize the particular waveguide/phase shifter element, each phase shifter may be separately cycled linearly in phase. In a good system the amplitude waveform at point A will go through a negative zero crossing as the phase is cycled through the 90 degree phase shifter point.

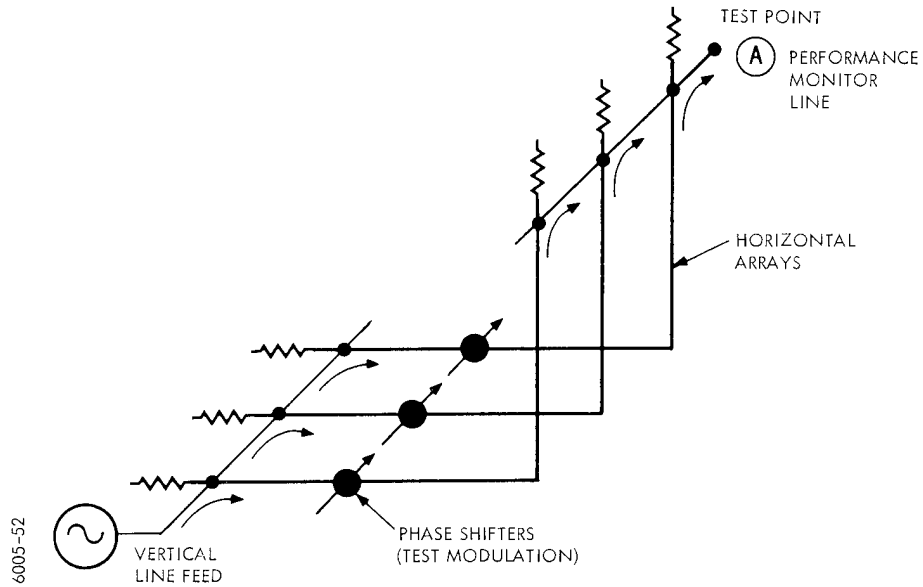

Fault Detection Approach Schematic

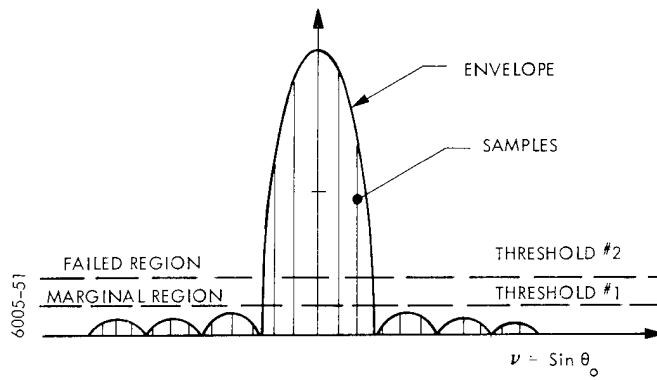

Monitored Signal for Antenna without Failures

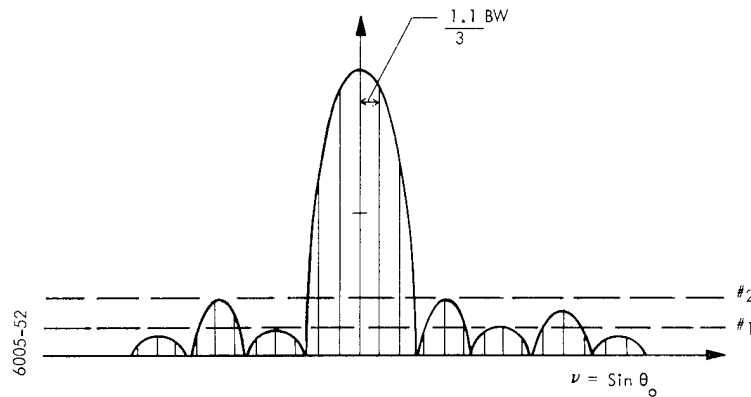

Monitored Signal for Antenna with Failures

Figure 32. Performance Monitoring Concept

A circuit coupled to point A, consisting of a gate seeking coincidence between a pulse generated at the negative zero crossing and another generated at the 90 degree phase instant, will provide an output if the element conditions are normal.

2.6.1 Performance Monitor Line. - The performance monitor line is connected between the last dual slot pair and the terminating load in each horizontal array section. The purpose of the performance monitor line is to collect the residual RF energy that is not radiated in each horizontal array. The residual energy is combined in the line and is detected by a diode detector connected to the lower end of the line by a coaxial line which is not a part of the antenna proper. The detected signal resulting from the combination of residual energy contributed from all elements is used to provide a dynamic check on antenna performance/status during operation.

The performance monitor line is fabricated in three separate sections using precision waveguide (0.400 x 0.900 inch inside dimension by 0.500 x 1.000 outside dimension) for the vertical feed line and smaller precision waveguide (0.400 x 0.750 inch inside by 0.476 x 0.826 inch outside dimension) for the horizontal coupling sections. The couplers, as will be noted are fabricated from the same material (type and size) as the horizontal array elements.

The coupling sections contain a milled nondirectional four port slot which couples the short horizontal sections to the vertical monitor line. Each coupling section is terminated with a matched loading block. The coupling coefficients of the sections are adjusted carefully to match the Taylor excitation generated by the vertical feed line. The coupling value is a function of slot length. The coupling values are maintained low in view of the low energy level required for the performance monitoring function.

The slot dimensions used for the 167 coupler sections in the ARBAT antenna are contained in Figure 33. Slot coupling values in voltage amplitude, coupling power ratio and coupling in dB on which the slot configurations were based are listed in Figure 34.

The performance monitor line is shown in the assembled antenna in Figure 35 and a closeup view of a section of the line shows mounting details (Figure 36).

SLOT WIDTH = 0.362 ±.002  
 FREQUENCY = 9.65000 GHz  
 A DIMENSION = 0.90000 IN.  
 B DIMENSION = 0.40000 IN.  
 POWER INTO LOAD = 0.60000 ( )  
 LENGTH OF SLOT IS GIVEN AS 1/2 LENGTH

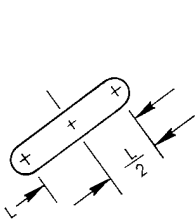

1	0.15634	43	0.15936	85	0.16267	127	0.16636
2	0.15641	44	0.15943	86	0.16275	128 40	0.16645
3	0.15648	45	0.15951	87	0.16283	129	0.16654
4	0.15655	46	0.15959	88 80	0.16292	130	0.16664
5	0.15662	47	0.15966	89	0.16300	131	0.16673
6	0.15669	48	0.15973	90	0.16309	132	0.16683
7	0.15676	49	0.15981	91	0.16317	133	0.16692
8	0.15683	50	0.15988	92	0.16325	134	0.16702
9	0.15689	51	0.15996	93	0.16334	135	0.16711
10	0.15696	52	0.16004	94	0.16342	136	0.16721
11	0.15703	53	0.16011	95	0.16351	137	0.16730
12	0.15711	54	0.16019	96	0.16359	138 30	0.16740
13	0.15718	55 113	0.16027	97	0.16368	139	0.16749
14	0.15725	56	0.16035	98 70	0.16377	140	0.16759
15	0.15732	57	0.16042	99	0.16385	141	0.16769
16	0.15739	58 110	0.16050	100	0.16394	142	0.16778
17	0.15746	59	0.16055	101 67	0.16402	143	0.16788
18	0.15753	60	0.16060	102	0.16411	144 24	0.16798
19	0.15760	61	0.16073	103	0.16420	145	0.16808
20	0.15767	62	0.16081	104	0.16428	146	0.16818
21	0.15774	63	0.16089	105	0.16437	147	0.16827
22	0.15781	64	0.16097	106	0.16446	148 20	0.16837
23	0.15789	65	0.16105	107	0.16455	149	0.16847
24	0.15796	66	0.16113	108 60	0.16464	150	0.16857
25	0.15803	67	0.16121	109	0.16472	151	0.16867
26	0.15810	68 100	0.16129	110	0.16481	152	0.16877
27	0.15817	69	0.16137	111	0.16490	153	0.16887
28	0.15825	70	0.16145	112	0.16499	154	0.16897
29	0.15832	71	0.16153	113	0.16508	155	0.16908
30	0.15839	72	0.16161	114	0.16517	156	0.16918
31	0.15847	73	0.16169	115	0.16526	157	0.16928
32	0.15854	74	0.16177	116	0.16535	158 10	0.16938
33	0.15861	75	0.16185	117	0.16544	159	0.16948
34	0.15869	76	0.16193	118 50	0.16553	160	0.16959
35	0.15876	77 91	0.16201	119	0.16562	161	0.16969
36	0.15883	78 90	0.16209	120	0.16571	162	0.16979
37	0.15891	79	0.16217	121	0.16580	163	0.16990
38	0.15898	80	0.16226	122	0.16589	164	0.17000
39	0.15906	81	0.16234	123	0.16599	165	0.17011
40	0.15913	82	0.16242	124	0.16608	166	0.17021
41	0.15921	83	0.16250	125	0.16617	167 1	0.17032
42	0.15928	84	0.16259	126	0.16626		

FREQUENCY = 9.65000 GHz  
 W.G. A DIMENSION = 0.90000 IN.  
 W.G. B DIMENSION = 0.40000 IN.  
 ELEMENT SPACING = 0.72000 IN.  
 TLM MODE(N,M) = 1.00000 0.00000  
 WAVEGUIDE LOSSES = 0.00255 DB

6005-47

Figure 33. Performance Monitor Slot Dimensions



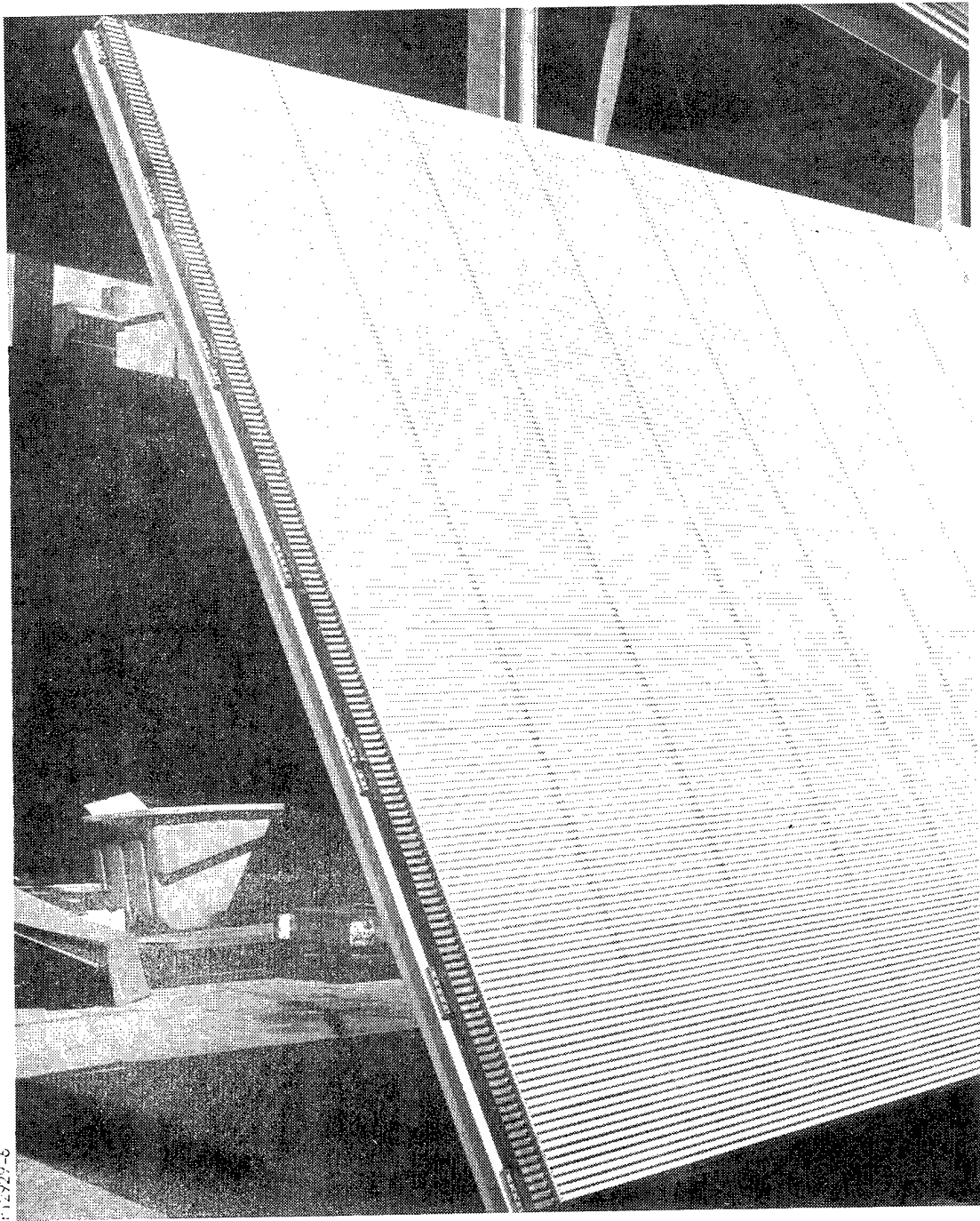

FIG 35-6

Figure 35. Performance Monitor Line in Assembled Antenna

P12929-7

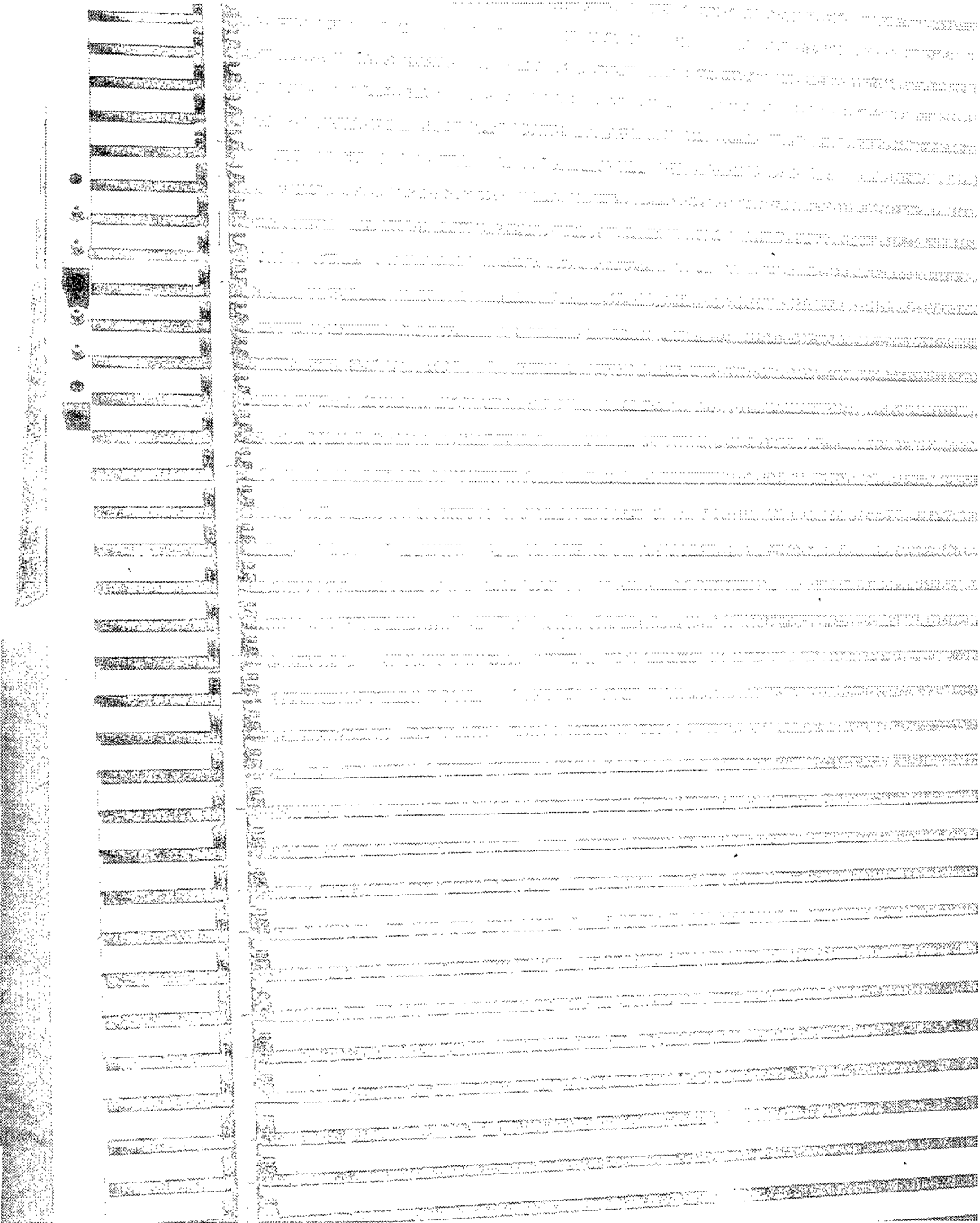

Figure 36. Performance Monitor Line (Close-Up View)

2.6.2 Loads: Performance Monitor Line. - Equalizing termination loads are required to terminate the horizontal array RF signal path, which in the ARBAT antenna is the extreme end of each coupling section attached to the performance monitor line. The performance monitor line loads are fabricated from material identical to that used for fabrication of the vertical line feed load elements, however the design and method of installation differs radically. These load elements are of uniform dimensions for all 167 elements. Oversize loads are molded from ECCOSORB 17 compound using an appropriate catalyst and milled to final dimensions. The load elements are chamfered at each edge of the surface contacting the wide dimension of the waveguide. In installation the load element is pressed into the waveguide together with a precut section of foam material the width of the load element and of a height to fully fill the space between the top of the element and the top inside wall of the waveguide above the load. The foam block holds the load firmly in place and epoxy adhesive is injected into the openings produced by the chamfer at each corner of the waveguide.

For detailed design of the load element see Drawing 140325, Load, Monitor (available at Picatinny Arsenal).

Load Tests. - Tests to ascertain the return loss (VSWR) of the final load design were run throughout the antenna operating frequency range. Results of the tests are shown in Figure 37.

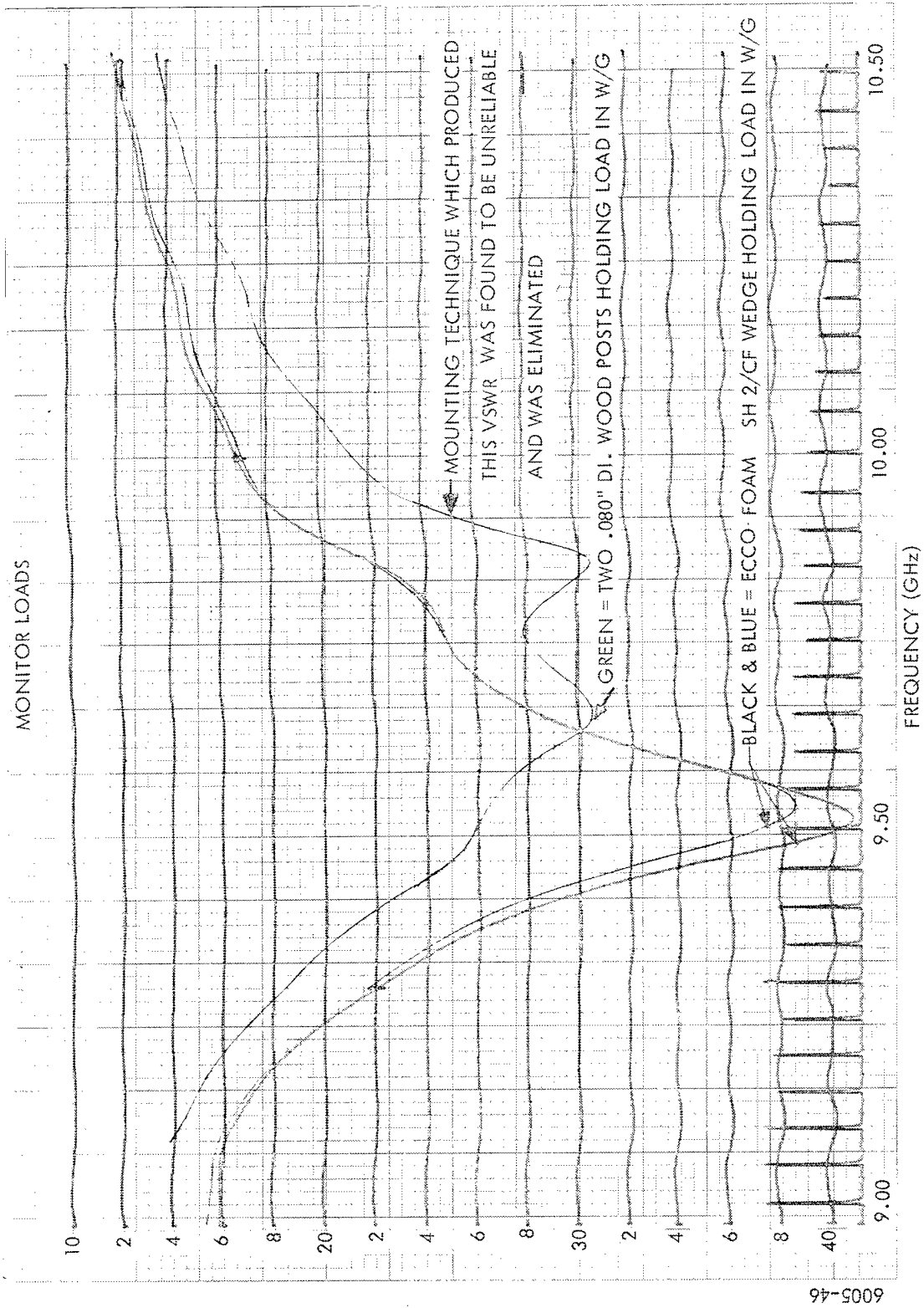

Figure 37. Load Block VSWR Measurement

### 3. TEST PROGRAM

#### Antenna Pattern Measurements

A major part of the ARBAT antenna development phase was the fabrication, testing, modification and retest of critical elements comprising the antenna subsystem. The procedure, which followed the paper design and computer analyses, was based on intermediate test results of single components followed by three\* array range tests. On completion of these tests and after incorporation of changes determined necessary to optimize component design, a nine element test array was assembled using the optimized components. The nine element array configuration was selected as the minimum number of elements capable of producing patterns that reliably reflect the validity of the component designs, providing a confident prediction of the complete array performance.

#### 3.1 Short Array (3 Section) Tests.

The 3 section array tests were made using a single excited horizontal array section between two "dummy" array sections positioned to provide a realistic environment for the active element. Short comb sections were used to maintain the relative positions of the three elements. The 3 section array was assembled and tested in the Van Nuys plant RF test chamber for insertion loss, VSWR (return loss) and phase error. The results of these tests are contained in the following figures. The last illustration is a computed pattern prediction based on the 3 element array phase and amplitude excitation measurements.

Figure 38. Horizontal Array Element Insertion Loss

Figure 39. Horizontal Array Element Return Loss

Figure 40. Horizontal Array Element Return Loss (Expanded D2 RL)

Figure 41. Predicted Pattern (3 Element Test)

---

\*One Excited Array and Two Dummy Arrays

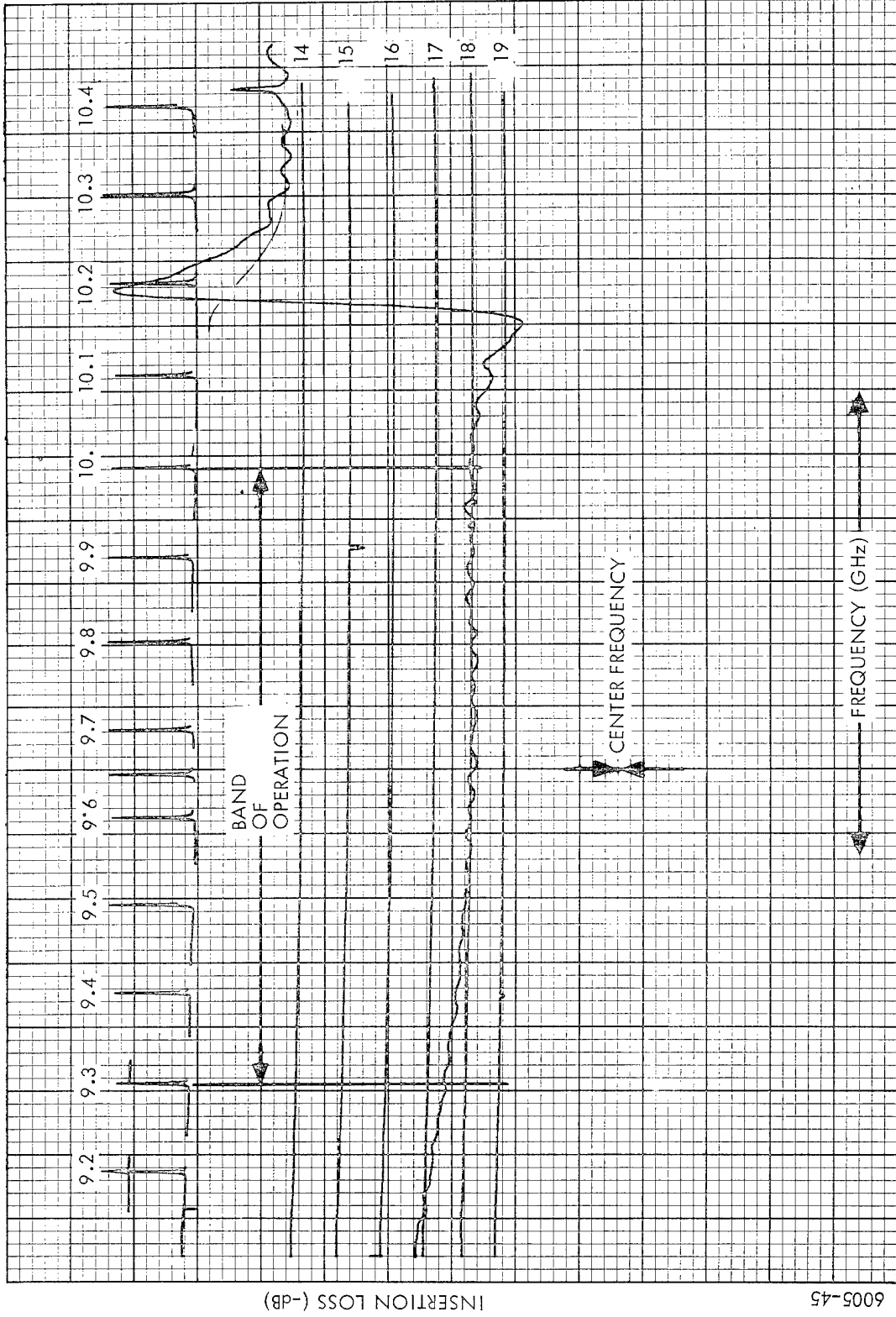
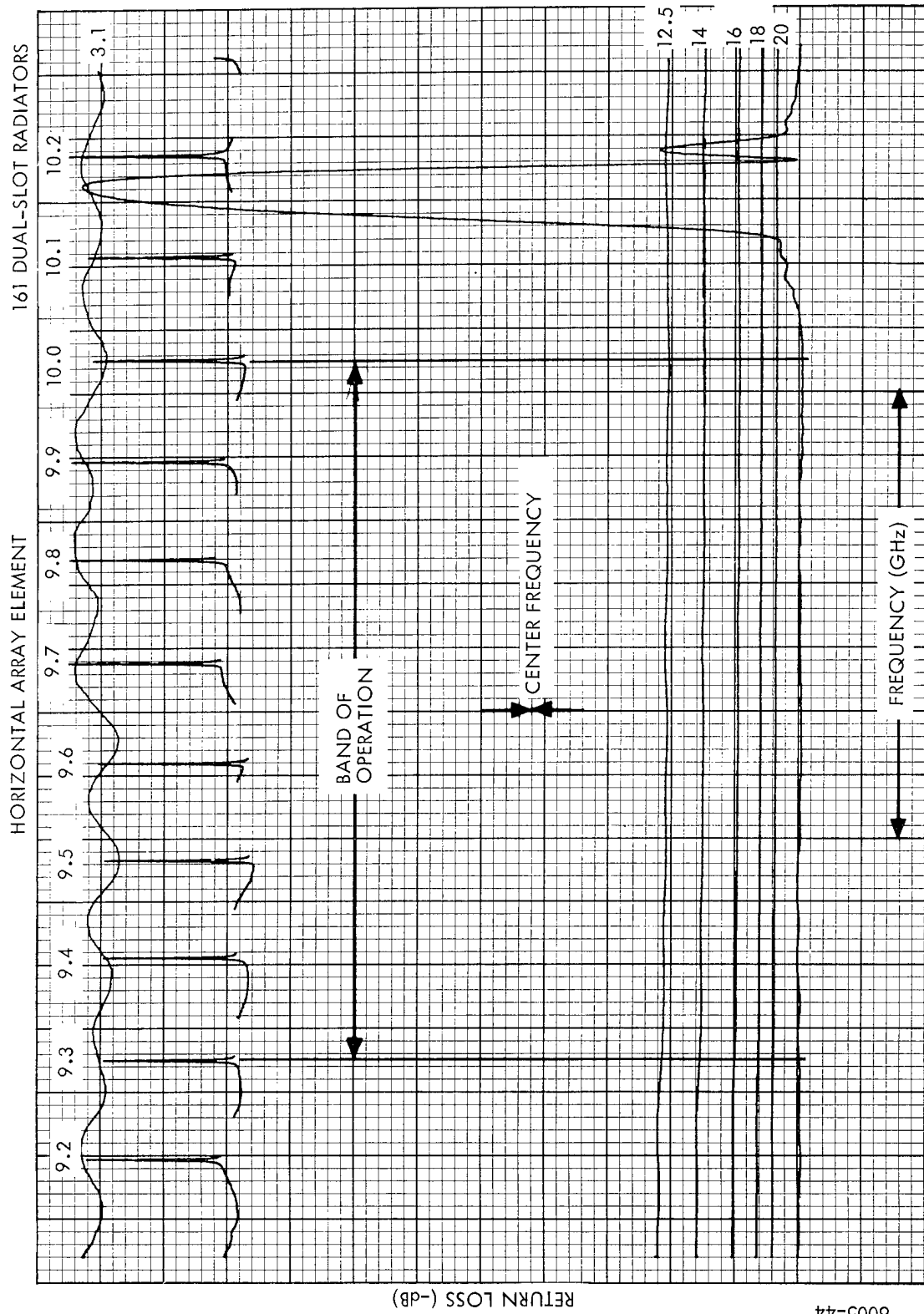

Figure 38. Horizontal Array Element Insertion Loss (Dual Slot Radiators)



6005-44

Figure 39. Horizontal Array Element Return Loss (Dual Slot Radiators)

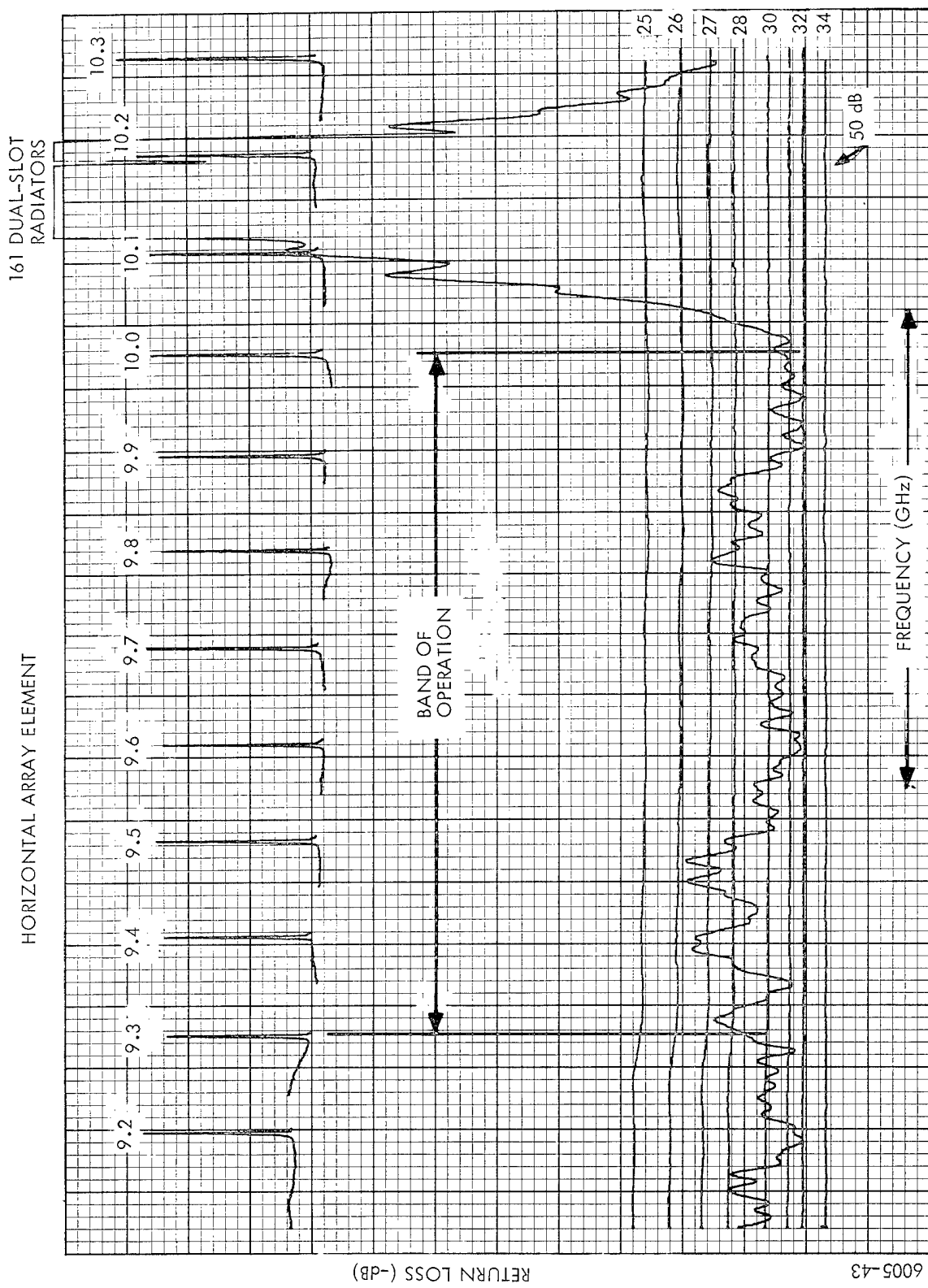

Figure 40. D-2 Horizontal Array Element Return Loss (Expanded D2 RL)

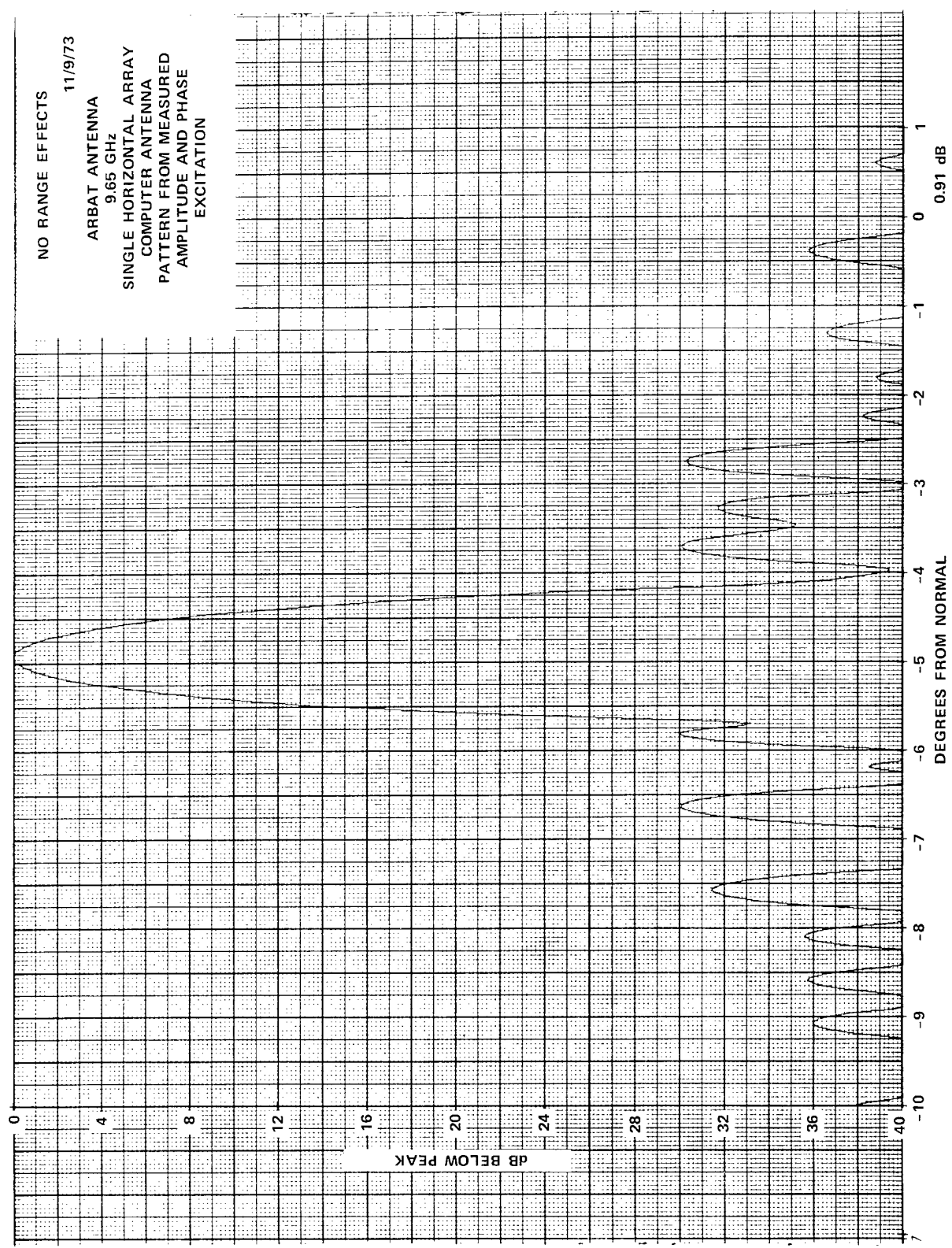

Figure 41. Predicted Pattern (3 Element Test)

### 3.2 Nine-Element Test Array

The nine-element range tests were designed to determine the validity of all previous tests and modifications resulting from intermediate single element testing and the three element tests in the preceding section. For the purpose of these tests it was necessary to introduce phase changes in each horizontal array input by means of small waveguide sections containing Rexolite phase shift blocks in lieu of the diode phase shifters which were not available. The phase shifting elements fabricated for these tests duplicate the electrical function of the phase shifters and insure that the results obtained are transferable to the same array if excited via the phase shifters which will be used in the operational system. Mechanically, the Rexolite block phase shift devices differed significantly from the actual diode phase shifter, as will be noted in the test array sketch, Figure 43, largely in that an "in-line" configuration was used in the test device assembly, whereas the diode phase shifters contain a 90 degree bend at the point at which the connection to the horizontal array is made. A quarter wave transformer was inserted between the phase shift test device and the horizontal array elements.

Horizontal array elements for the nine-element test array included one array element fabricated during the earlier tests in which a single array was tested singly and mounted between two "dummy" elements to form a three-array assembly. In order to provide a realistic electrical environment for the nine-element array, a "dummy" horizontal element was positioned on the outside of the first and last excited elements in the test assembly.

A short vertical feed line was fabricated for use with the test array assembly. The nine-element test array pictorial schematic is shown in Figure 42. The test array is shown mounted on a test fixture during range tests in Figure 43.

After alignment of the test array with the transmitting antenna, tests were conducted to determine elevation scan angles versus phase shift increments and azimuth patterns at beam normal, mid scan, and at scan limits. All tests were repeated at 9.3, 9.65 and 10.0 GHz.



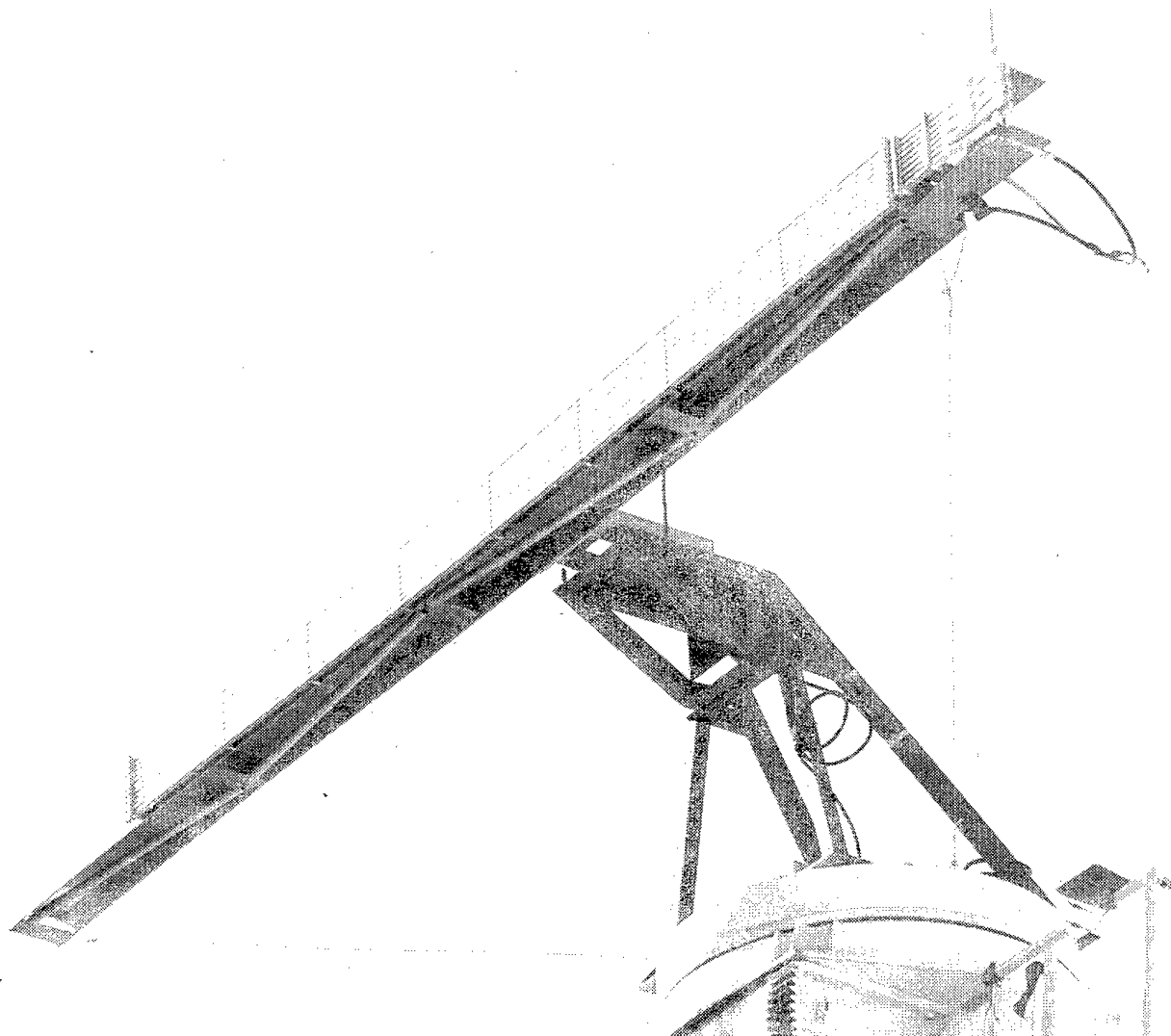

P12583-9

Figure 43. Nine-Element Test Array Assembled

<u>ITEM</u>	<u>SCAN ANGLE ELEVATION (DEG)</u>	<u>FREQ GHZ</u>	<u>Ø BLOCKS</u>	
1	0.0	9.3	1. 0.0	6. 180
			2. 45	7. 225
			3. 67.5	8. 247.5
			4. 112.5	9. 292.5
			5. 135	
2	0.0	9.65	1. 0	6. 135
			2. 22.5	7. 157.5
			3. 45	8. 180
			4. 67.5	9. 202.5
			5. 90	
3	0.0	10.0	1. 0.0	6. 67.5
			2. 22.5	7. 90
			3. 22.5	8. 112.5
			4. 45	9. 112.5
			5. 67.5	
4	-17.5	9.3	1. 0	6. 225
			2. 337.5	7. 202.5
			3. 315	8. 180
			4. 292.5	9. 157.5
			5. 247.5	
5	-17.5	9.65	1. 0.0	6. 157.5
			2. 315	7. 135
			3. 292.5	8. 90
			4. 247.5	9. 45
			5. 202.5	
6	-17.5	10.0	1. 0	6. 112.5
			2. 315	7. 45
			3. 270	8. 0
			4. 202.5	9. 315
			5. 157.5	
7	-35	9.3	1. 0	6. 315
			2. 270	7. 225
			3. 202.5	8. 157.5
			4. 112.5	9. 67.5
			5. 45	
8	-35	9.65	1. 0	6. 247.5
			2. 270	7. 135
			3. 157.5	8. 45
			4. 67.5	9. 315
			5. 337.5	
9	-35	10.0	1. 0	6. 157.5
			2. 247.5	7. 45
			3. 135	8. 292.5
			4. 22.5	9. 180
			5. 270	

Figure 44. Nine-Element Test Array Elevation Scan

JAN 28 1976

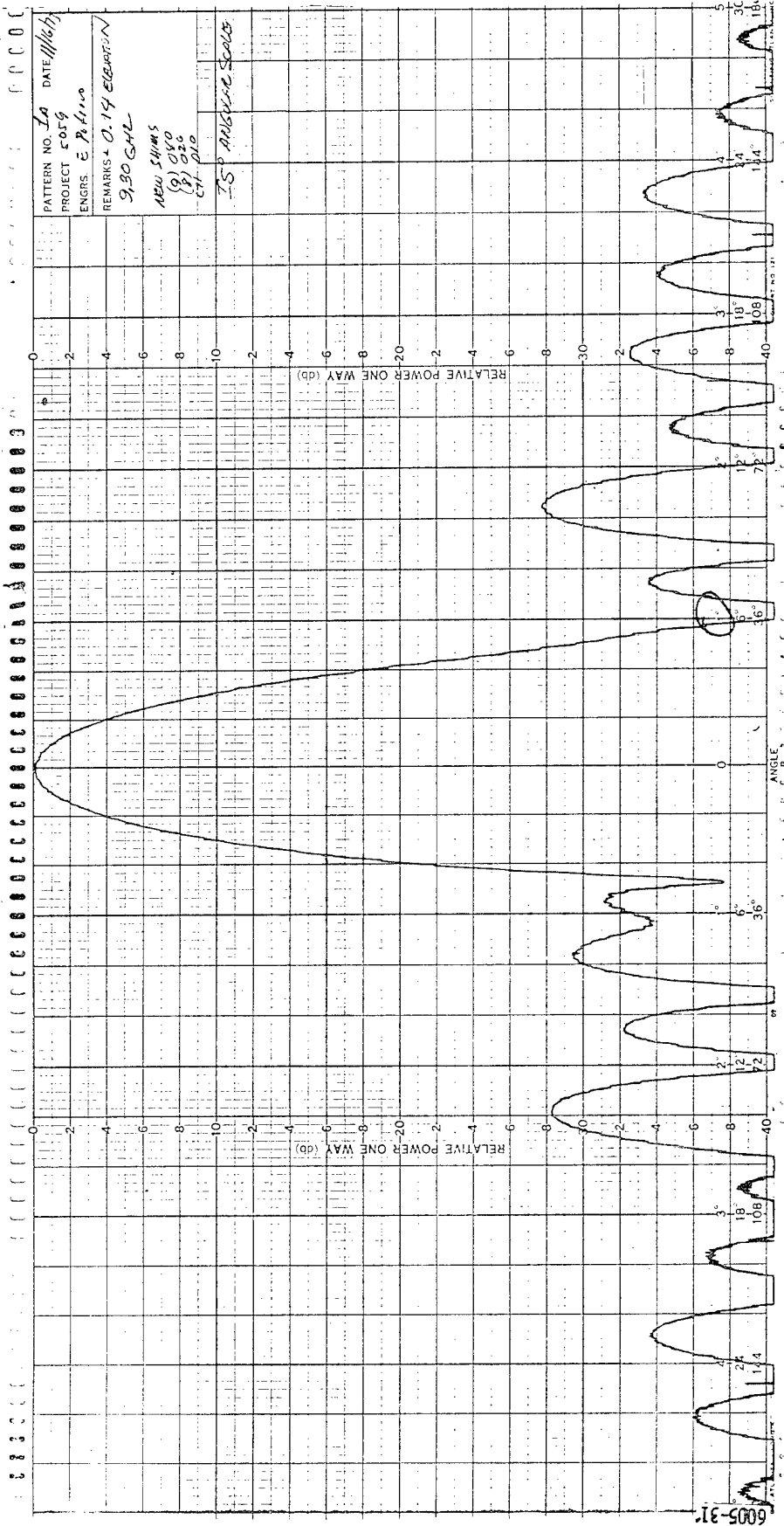

Figure 45. ARBAT 9-Element Test Array Pattern (Beam Normal) (9.30 GHz)

JAN 28 1978

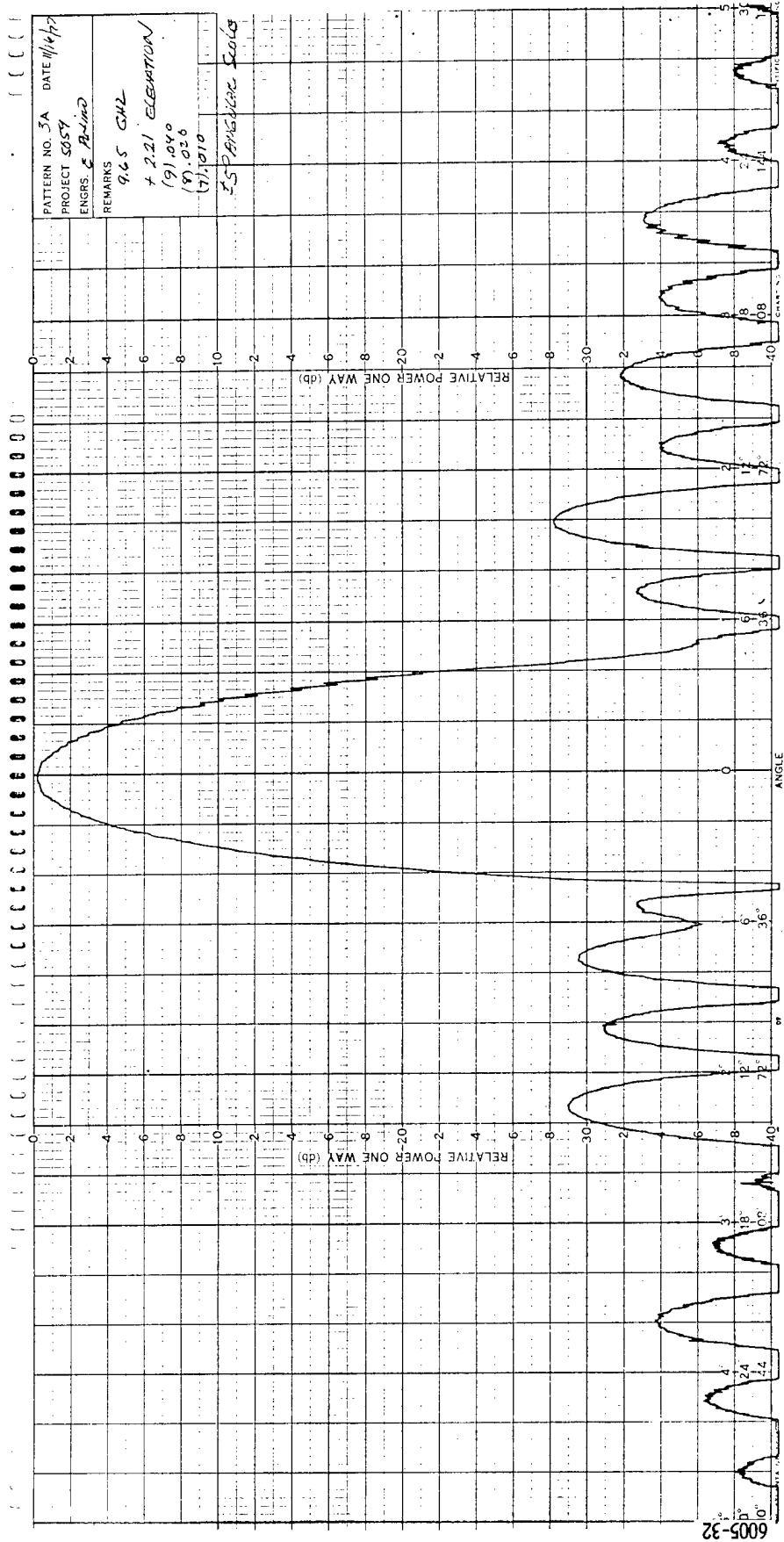

Figure 46. ARBAT 9-Element Test Array Pattern (Beam Normal) (9.65 GHz)

JAN 28 1976

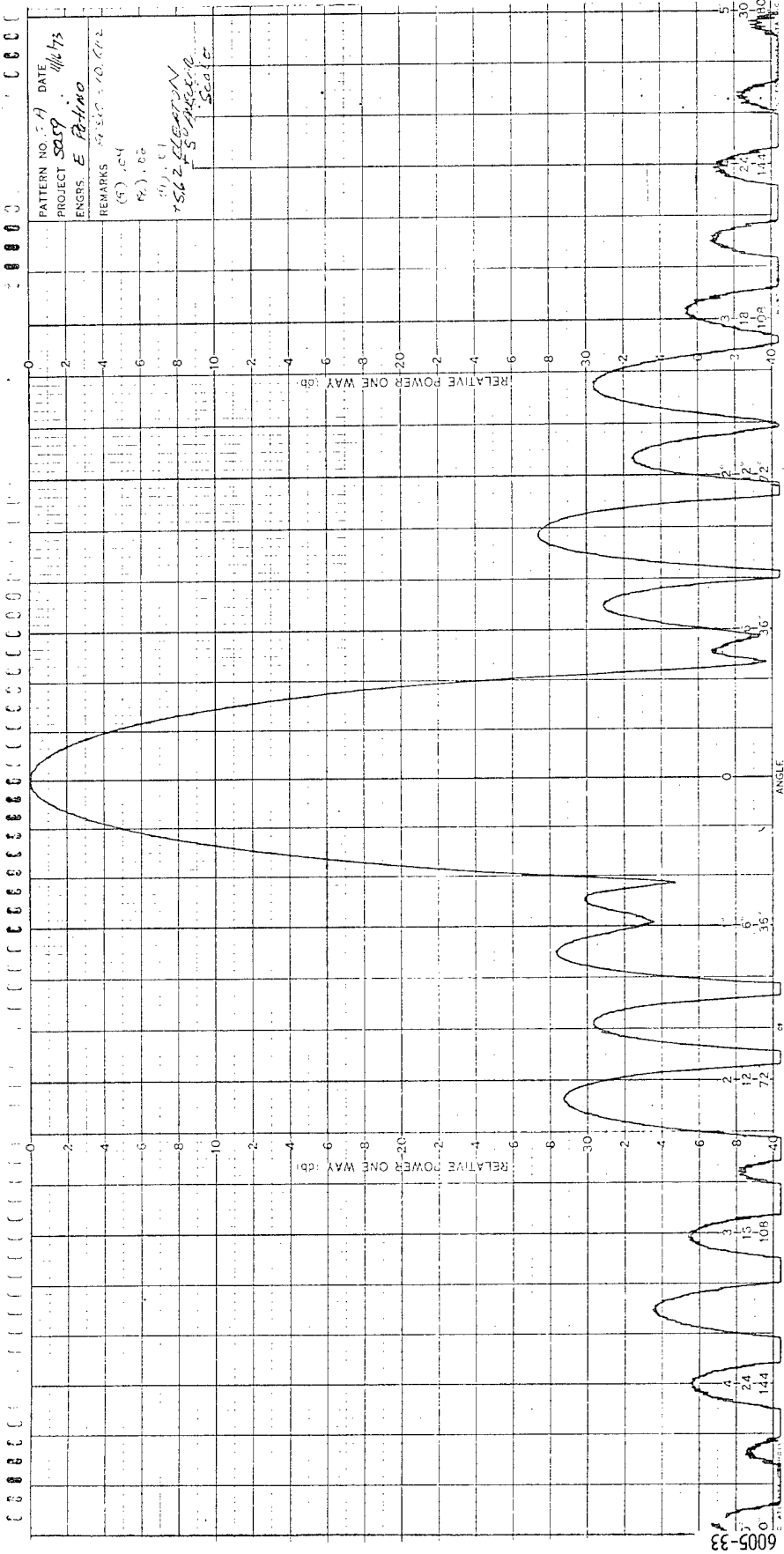

Figure 47. ARBAT 9-Element Test Array Pattern (Beam Normal) (10.0 GHz)

JAN 28 1976

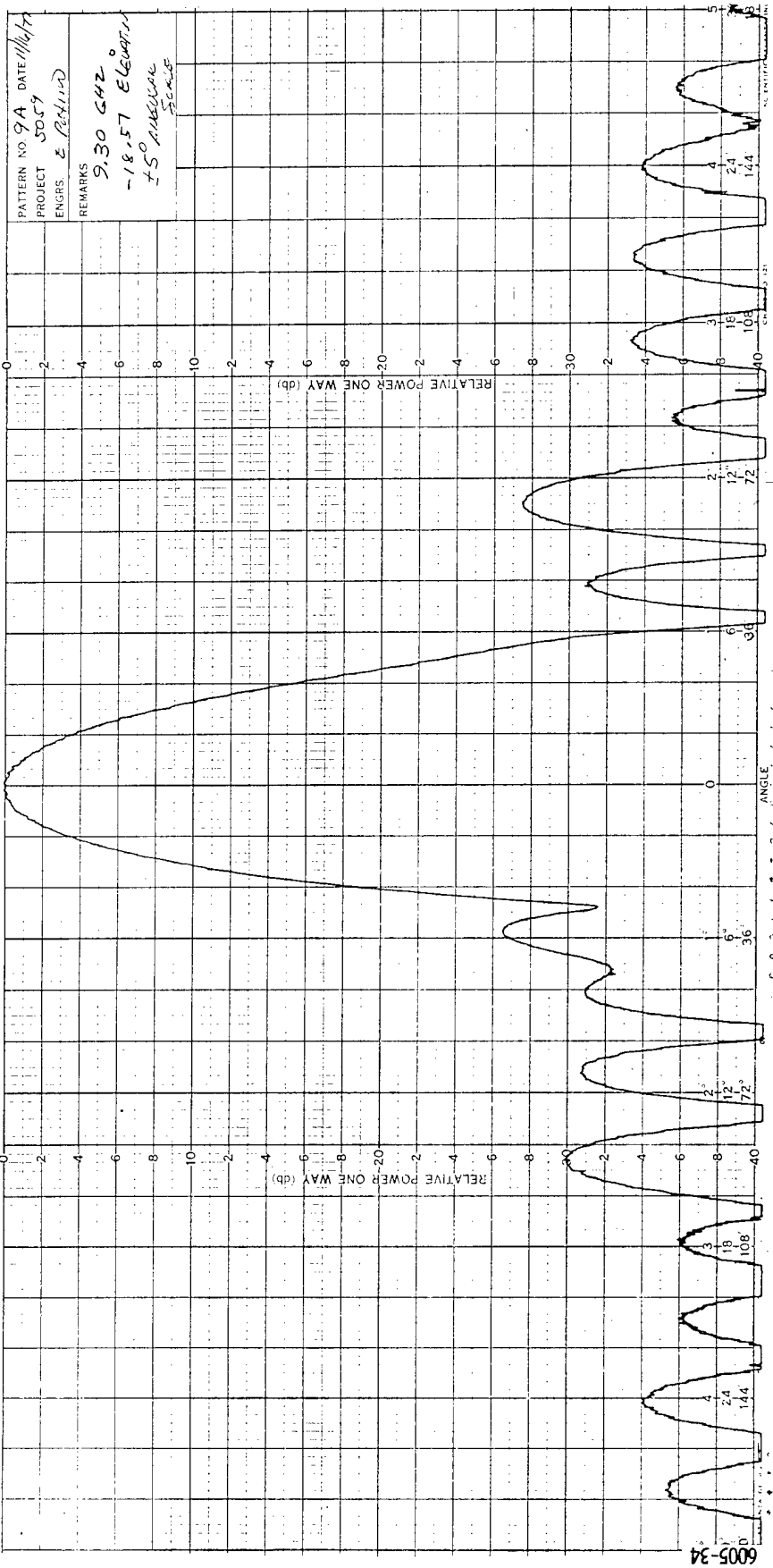

Figure 48. ARBAT 9-Element Test Array Pattern (Mid-Scan) (9.3 GHz)

JAN 28 1976

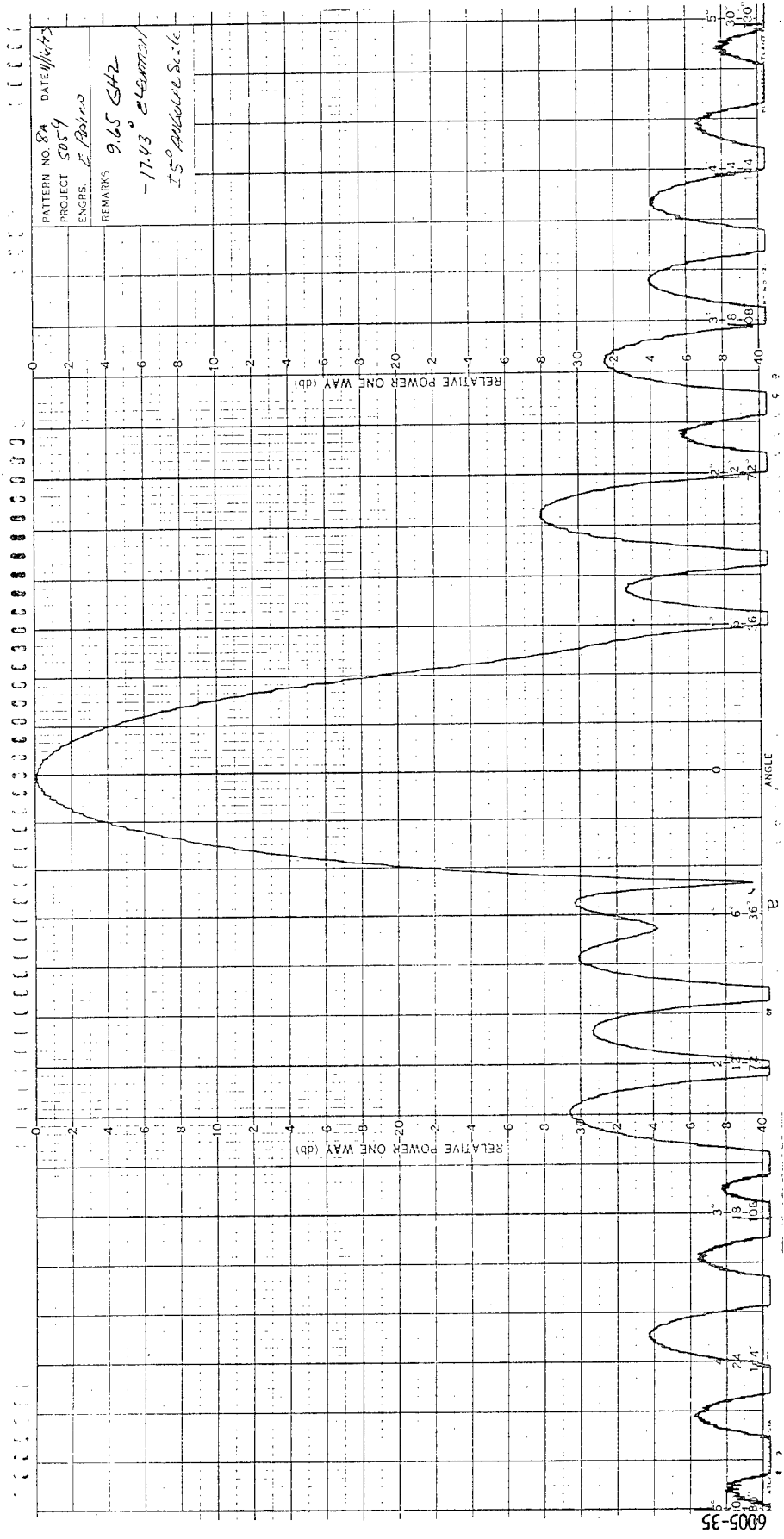

Figure 49. ARBAT 9-Element Test Array Pattern (Mid-Scan) (9.65 GHz)

JAN 28 1976

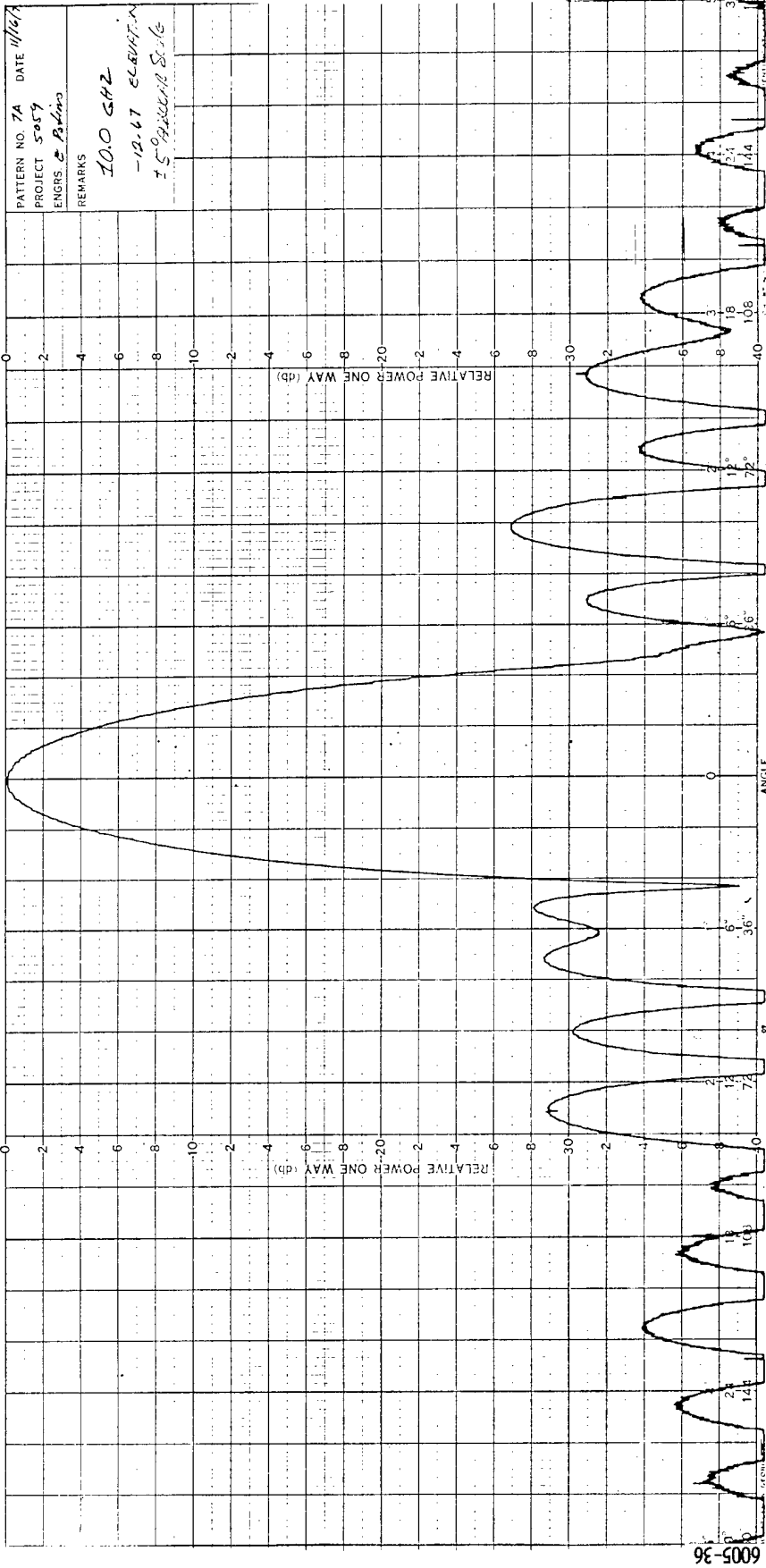

Figure 50. ARBAT 9-Element Test Array Pattern (Mid-Scan) (10.0 GHz)

JAN 28 1976

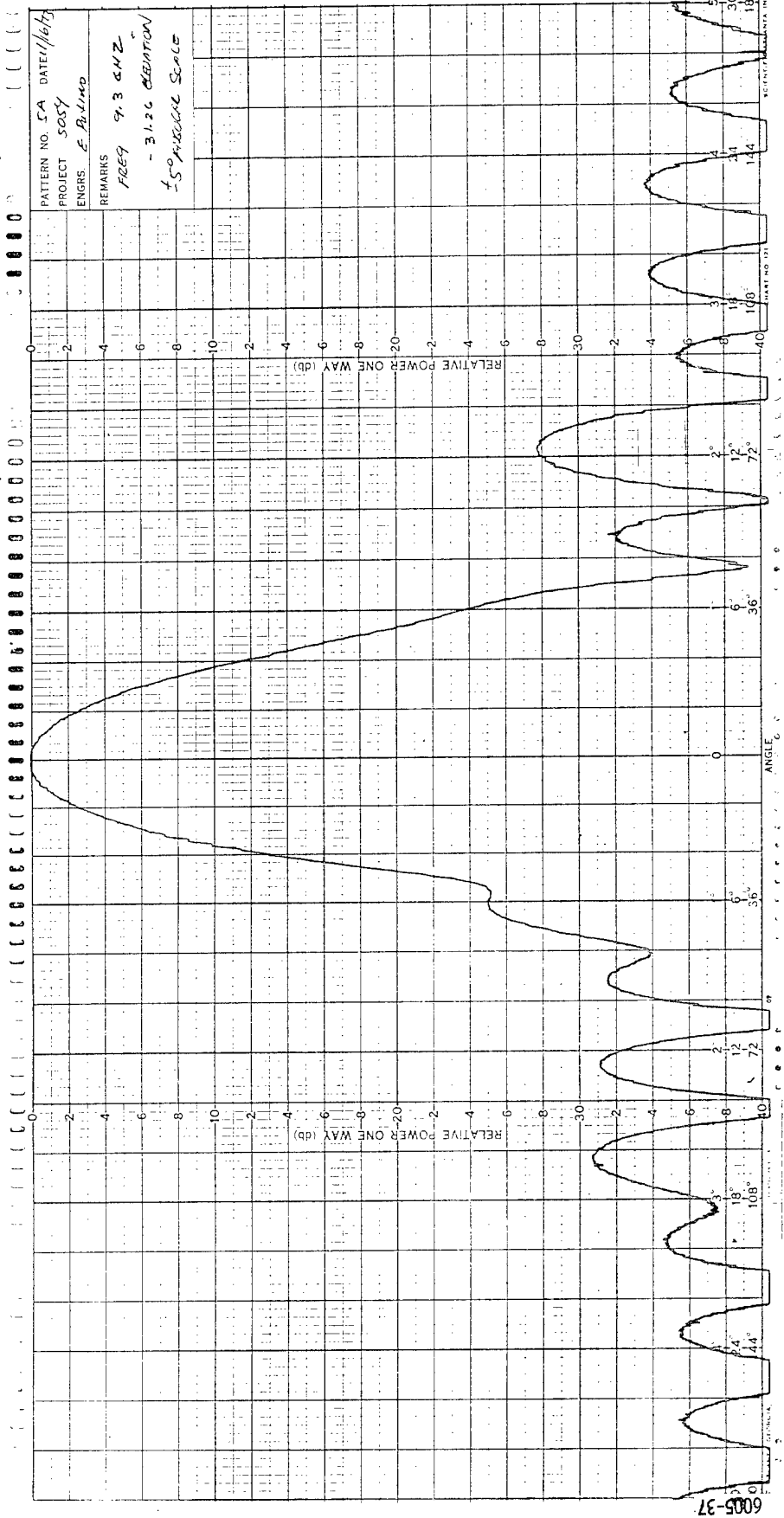

Figure 51. ARBAT 9-Element Test Array Pattern (Scan Limit) (9.3 GHz)

JAN 28 1976

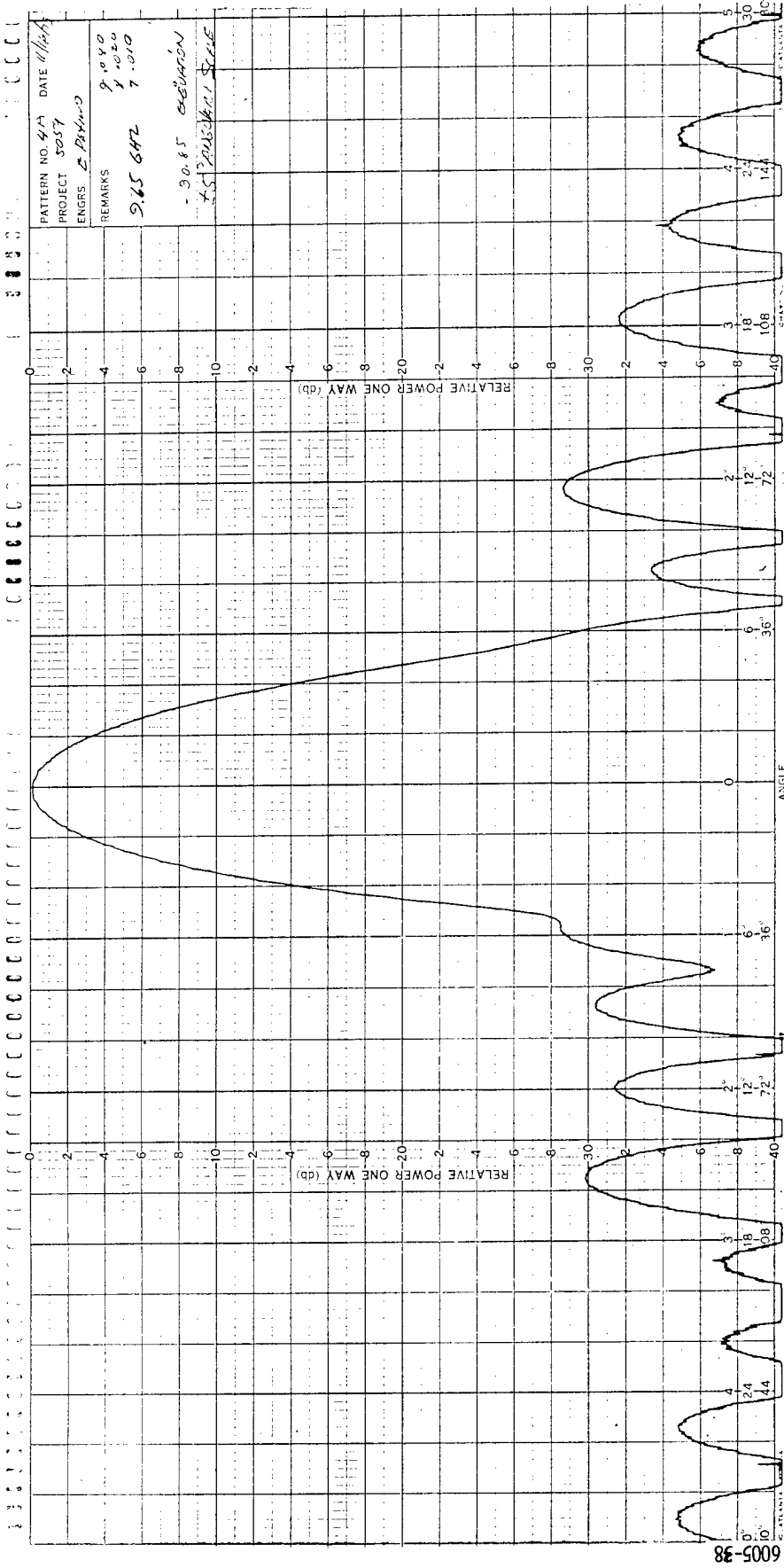

Figure 52. ARBAT 9-Element Test Array Pattern (Scan Limit) (9.65 GHz)

JAN 28 1976

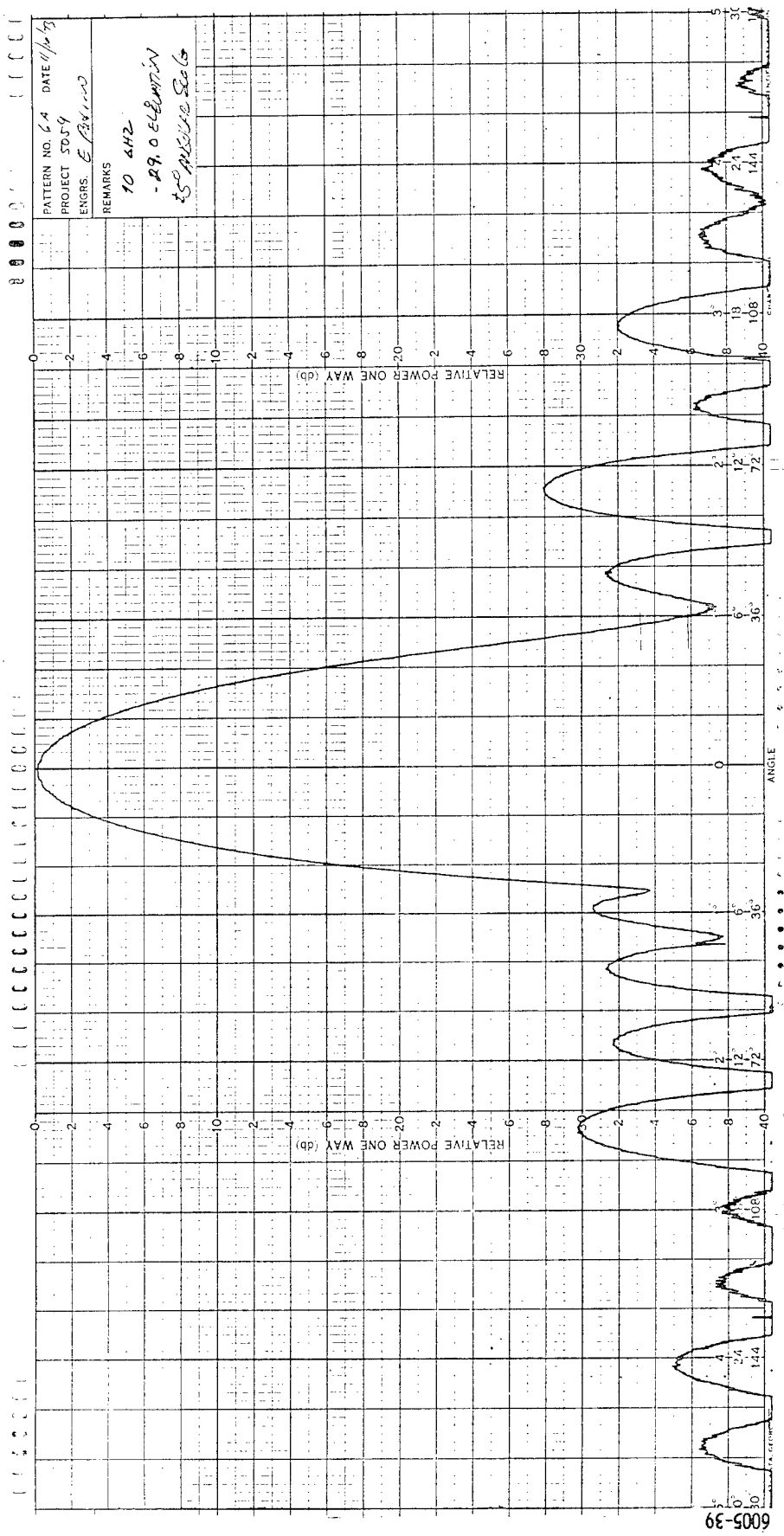

Figure 53. ARBAT 9-Element Test Array Pattern (Scan Limit) (10.0 GHz)

JAN 28 1976

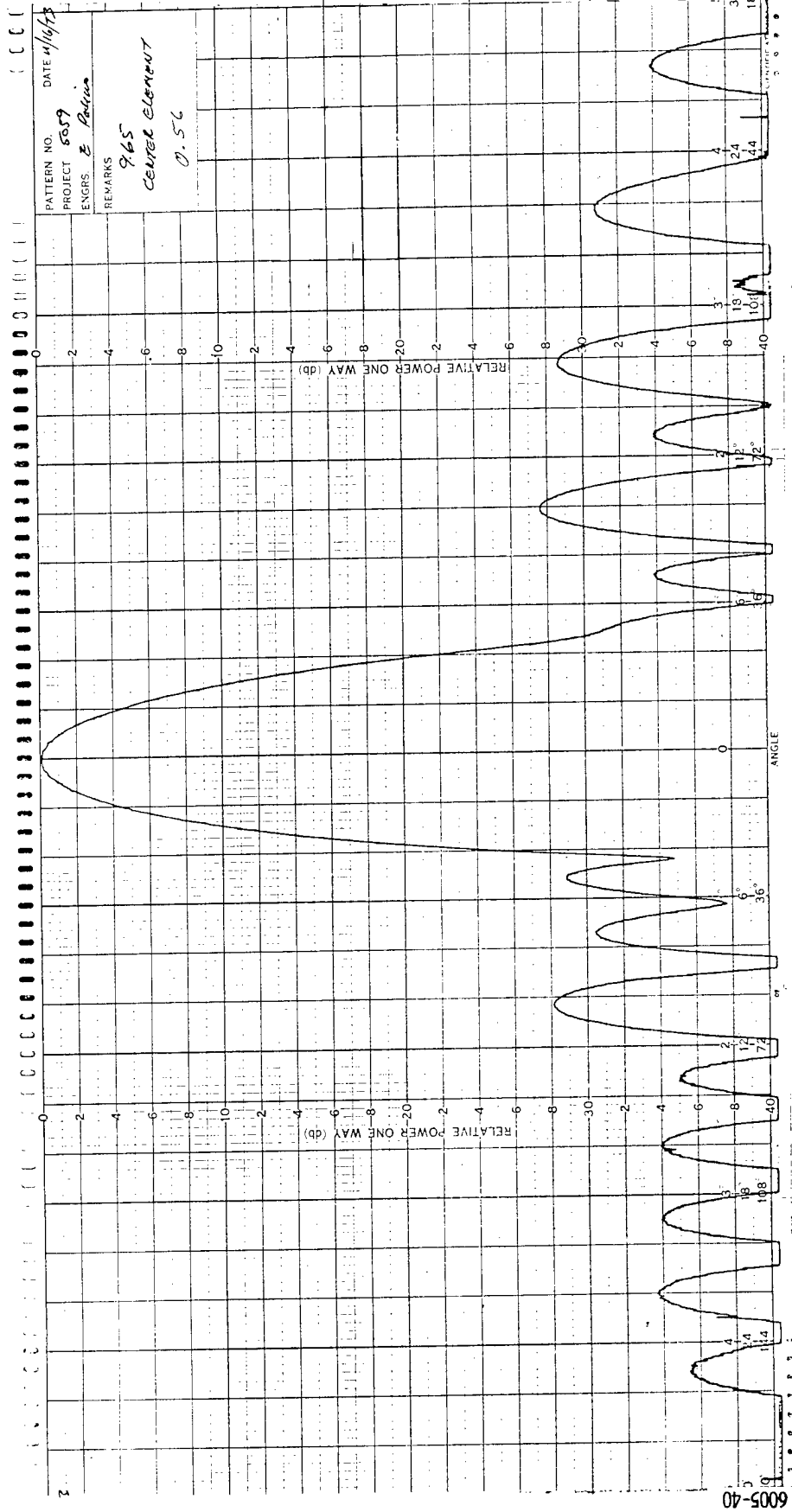

Figure 54. ARBAT 9-Element Test Array Pattern (Center Element Broadside) (9.65 GHz)

#### 4. SUMMARY OF TEST RESULTS

Test results throughout the ARBAT antenna development program have been consistent with the design goals and with the performance of both component parts tested individually and as partial arrays.

Scan coverage and radiation patterns demonstrated in the nine-element test array range testing program were in accordance with the design requirement and predicted performance.

Based on extensive experience in the development of similar antenna subsystems, the results from the 9-element tests can be assumed to be reliably indicative of the full (167 element) array performance with the operational phase shifters.

APPENDIX A  
STRUCTURES ANALYSIS

PREPARED	NAME -PS	DATE 1/30/73	ITT Gilfillan Inc.	SHEET	OF
CHECKED		TITLE PROJECTILE TRACKING RADAR STRUCTURES ANALYSIS		SKETCH NO.	
APPROVED					

TRAILER MOUNTED ANTENNA

DESIGN PARAMETERS

1. ERROR (a) TOTAL BUDGET ERROR  $(\epsilon_t) = 2.0$  MILLIRADIAN

(b) ASSUMED MECHANICAL ERROR FROM ANTENNA TO DATA TAKE-OFF = 25% OF TOTAL

$(\epsilon_m) = 0.50$  M.R.

THIS IS THE SUM OF THE ERRORS OF ANTENNA, TORQUE STRUCTURES, TORQUE TUBE, AZIMUTH CRG, & DATA TAKE-OFF BOX.

(c) TRAILER & JACK SYSTEM ERROR

$(\epsilon_{j+t}) = 0.25$  M.R.

2. TEMPERATURE

(a)  $T_{max} = 165^{\circ}F$   
 $T_{min} = -65^{\circ}F$  } EQUIPMENT SHALL OPERATE

(b)  $T_{max} = 120^{\circ}F$   
 $T_{min} = -20^{\circ}F$  } EQUIPMENT SHALL OPERATE WITH ACCURACY REQUIREMENTS BEING MAINTAINED.

3. WIND LOADS

(a)  $V_o = 30$  MPH @  $-20^{\circ}F$   $q_o = .0028 V_o^2 = 2.52$  PSF (OPERATING)

(b)  $V_e = 75$  MPH @  $-65^{\circ}F$   $q_s = .00335 V_s^2 = 18.85$  PSF (SURVIVAL)

4. SHOCK

(a)  $n_x, n_y \& n_z = 10$  g's (TRUCK TRANSPORT MODE)

(b)  $n_x \& n_y = 20$  g's MAX (RAILROAD HUMPING IMPACT)

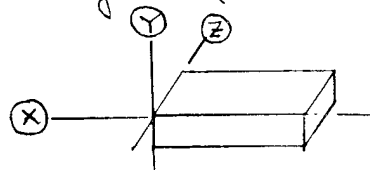

NORMAL TRANSPORT COORDINATE SYSTEM

X" AXIS - FORE & AFT

Z AXIS - CURBSIDE & ROADSIDE

PREPARED	NAME APD	DATE 1/30/73	ITT Gilfillan Inc.	SHEET 2 OF
CHECKED			TITLE PROJECTILE TRACKING RADAR STRUCTURES ANALYSIS	SKETCH NO.
APPROVED				

5. AZIMUTH TRACKING - REQUIREMENTS  
ANGULAR VELOCITY & ACCELERATION ANALYSIS

PER P 2.5.2

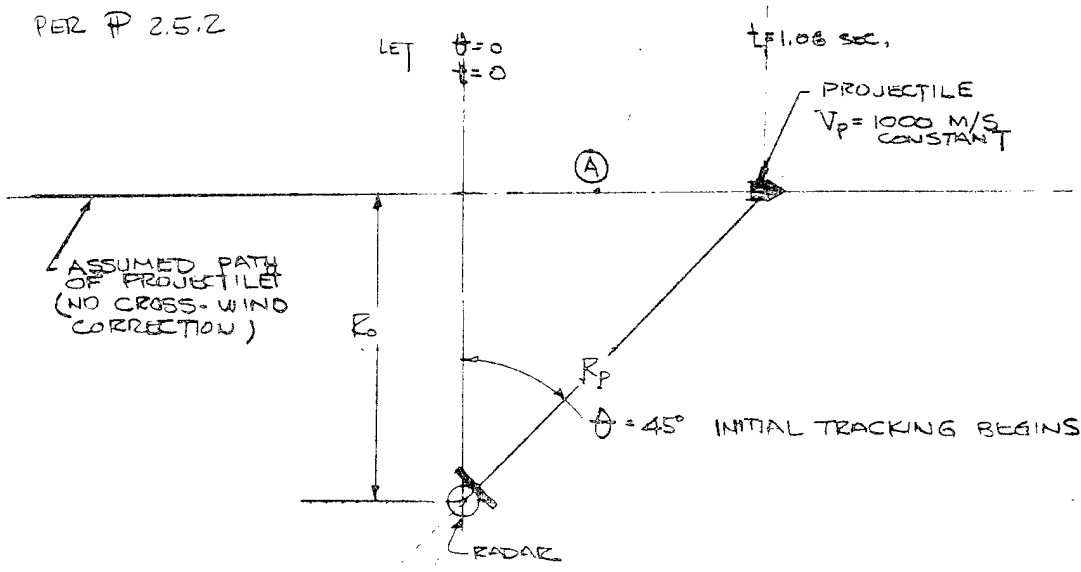

CONSIDER PROJECTILE AT ANY TIME "t"

BY DEFINITION  $R_0 = R_p \cos 45^\circ$

$$\therefore \tan \theta = \frac{V_p t}{R_0}$$

$$\theta = \tan^{-1} \frac{V_p t}{R_0} \quad \text{--- (1)}$$

$$\frac{d\theta}{dt} = \frac{V_p / R_0}{1 + \left(\frac{V_p t}{R_0}\right)^2} \quad \text{--- (2)}$$

$$\frac{d^2\theta}{dt^2} = \frac{-2 \left(\frac{V_p}{R_0}\right)^3 t}{\left[1 + \left(\frac{V_p t}{R_0}\right)^2\right]^2} \quad \text{--- (3)}$$

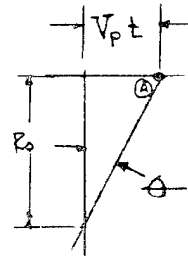

PREPARED	NAME APD	DATE 1/30/73	ITT Gilfillan Inc.	SHEET 3 OF
CHECKED			TITLE PROJECTILE TRACKING RADAR	SKETCH NO.
APPROVED			STRUCTURES ANALYSIS	

AZIMUTH TRACKING

ANGULAR VELOCITY & ACCELERATION (CONT'D)

SOLVE FOR INITIAL STARTING TIME  $t_i$  @  $\theta = 45^\circ$

$$\therefore \tan 45^\circ = 1.0 = \frac{V_p t_i}{R_0}$$

$$t_i = \frac{R_0}{V_p} = \frac{R_0 \cos 45^\circ}{V_p} \quad \text{LET } R_0 = 1500 \text{ M}$$

$$= \frac{1500 \times 0.707}{1000}$$

$$t_i = 1.06 \text{ SEC.}$$

PER # 2.1 REQUIREMENTS

WITH ELECTRONIC SCAN @  $\pm 3.5^\circ/\text{SEC}$ .

$$\dot{\theta} = 40^\circ/\text{SEC} = 0.70 \text{ RAD/SEC}$$

$$\ddot{\theta} = 40^\circ/\text{SEC}^2 = 0.70 \text{ RAD/SEC}^2$$

SOLVE FOR MINIMUM  $R_p$  TO SATISFY BOTH CONDITIONS @  $45^\circ$  ORIENTATION

$$\dot{\theta} = \frac{V_p}{2R_p \cos 45^\circ} = 0.70 \text{ RAD/SEC}$$

$$R_p = 1010 \text{ METERS} \quad \text{BUT } \ddot{\theta} = 0.98 \text{ RAD/SEC}^2$$

$$t_i = .714 \text{ SEC} \quad \text{@ } t=0$$

SOLVE EQU (3) FOR  $R_p$  FOR  $\ddot{\theta} = 0.70 \text{ RAD/SEC}^2$

$$\dot{\theta} = \frac{-2 \left( \frac{V_p}{R_p \cos 45^\circ} \right)^2 t_i}{\left[ 1 + \left( \frac{V_p t_i}{R_p \cos 45^\circ} \right)^2 \right]^2} = 0.70$$

$$R_p = 1200 \text{ METERS}$$

$$\ddot{\theta} = 33.8^\circ/\text{SEC} = 0.6 \text{ RAD/SEC}$$

$$t_i = .8484 \text{ SECS.}$$

PREPARED	NAME APD	DATE 11/30/73	<b>ITT Gilfillan Inc.</b>	SHEET 4 OF
CHECKED			TITLE <u>PROJECTILE TRACKING RADAR</u>	SKETCH NO.
APPROVED			STRUCTURES ANALYSIS	

## ANTENNA SYSTEM

INTRODUCTION : THE ANTENNA SYSTEM WILL BE MOUNTED ON A VEHICLE BED WITH JACK PAD PROVISIONS TO LIFT THE ENTIRE OR PORTION OF THE SPRUNG MASS OF THE VEHICLE-ANTENNA SYSTEM. THE ANTENNA WILL BE OF ARRAY WITH PHASE SHIFTER TYPE DESIGN ATTACHED TO A CENTER MAIN STRONG BACK STRUCTURE WHICH SERVES AS A TORQUE TUBE AS WELL AS A CANTILEVER BEAM FOR ELEVATION BENDING MOMENT. THE ANTENNA WILL HAVE A MAXIMUM TILT OF  $25^{\circ}$  WITH THE VERTICAL AXIS. THE TRANSCIVER ASSEMBLY WILL BE MOUNTED TO THE MAIN BACK STRUCTURE SO POSITIONED FOR MINIMUM MASS MOMENT OF INERTIA EFFECT ABOUT THE AZIMUTHAL AXIS.

THE ANTENNA SYSTEM WILL BE ASSEMBLED TO A PEDESTAL WHICH HOUSES THE BULL GEAR - BEARING ASSEMBLY, DRIVE MOTOR, GEAR BOX & DATA TAKE-OFF. EXISTING AN/SPS-48 PEDESTAL CAN EASILY BE ADAPTED IN THIS DESIGN. THE PEDESTAL IN TURN IS PERMANENTLY BOLTED TO THE TRAILER BED. THE TRAILER IN THE JACKED POSITION SHALL BE SO DESIGNED TO ACT AS NEARLY RIGID FOR SUDDENLY APPLIED TORSIONAL LOAD AT THE PEDESTAL BASE. THE JACK-PADS WILL REST ON A PREPARED ON-SITE GROUND FOOTING. THE 8 HOURS SET UP TIME CAN BE ACHIEVED. THE JACK ASSEMBLY LATERAL DEFLECTION (WHICH INCLUDES ANY ATTACHMENT TO THE TRAILER BODY) SHALL BE HELD TO AN ACCEPTABLE LIMIT UNDER OPERATING CONDITIONS.

PREPARED	NAME APD	DATE 1/31/73	ITT Gilfillan Inc.	SHEET 5 OF
CHECKED				SKETCH NO.
APPROVED				
			TITLE PROJECTILE TRACKING RADAR STRUCTURES ANALYSIS	

ANTENNA SYSTEM WEIGHTS

WEIGHT ANALYSIS - "X" BAND RADAR

COMPONENTS

(1) BASIC W.G. ARRAYS 2004 FT @ .12#/FT	= 240 LBS
(2) W.G. FLANGES (167) & HARDWARES	= 30 LBS
(3) PHASE SHIFTERS (167 @ .9# EA)	= 150 LBS
(4) LINE FEED W.G. + BENT TRANSITION	= 25 LBS
(5) BUFFER BEAM, STEERING	= 25 LBS
(6) POWER SUPPLY	= 50 LBS
(7) CABLE, BUS BAR, DEHYDRATOR, ETC	= 30 LBS
(8) TRANSCIVER ASSY	= 375 LBS
(9) COOLING FANS	= 15 LBS
<hr/>	
SUB-TOTAL (1)	= 940 LBS

STRUCTURES & HOUSINGS

(1) USING AN/SPS-48 PEDESTAL (ROTATING MASS ONLY)	
(a) TOP PLATE ADAPTER ( $D_o = 46.01W$ , $D_i = 24.01W$ ) + CLEAVISES	= 120 LBS
(b) INNER BRG RACE $A = 5.0 IN^2$ $D_{AV} = 37.01W$	= 170 LBS
<hr/>	
SUB-TOTAL (2)	= 290 LBS
(2) PHASE SHIFTER HOUSING + TRANSITION PLATE	= 50 LBS
(3) COMPONENT ITEMS (5) (6) & (7) HOUSING	= 20 LBS
(4) CENTER MAIN TORQUE-BOX BEAM TUBE $t = 0.25$ , $240 \times 32.0$	= 350 LBS
(5) TRUSS MEMBERS 275 FT @ 1.31 #/FT	= 360 LBS
(6) 10 TON ACTUATOR #1810	= 60 LBS
<hr/>	
SUB-TOTAL (3)	= 840 LBS

TOTAL WEIGHT  
ROTATING MASS = 2070 LBS

PREPARED	NAME JPD	DATE 11/30/73	<b>ITT Gilfillan Inc.</b>	SHEET 6 OF
CHECKED			TITLE PROJECTILE TRACKING RADAR	SKETCH NO.
APPROVED			STRUCTURES ANALYSIS	

MASS DISTRIBUTION ANALYSIS

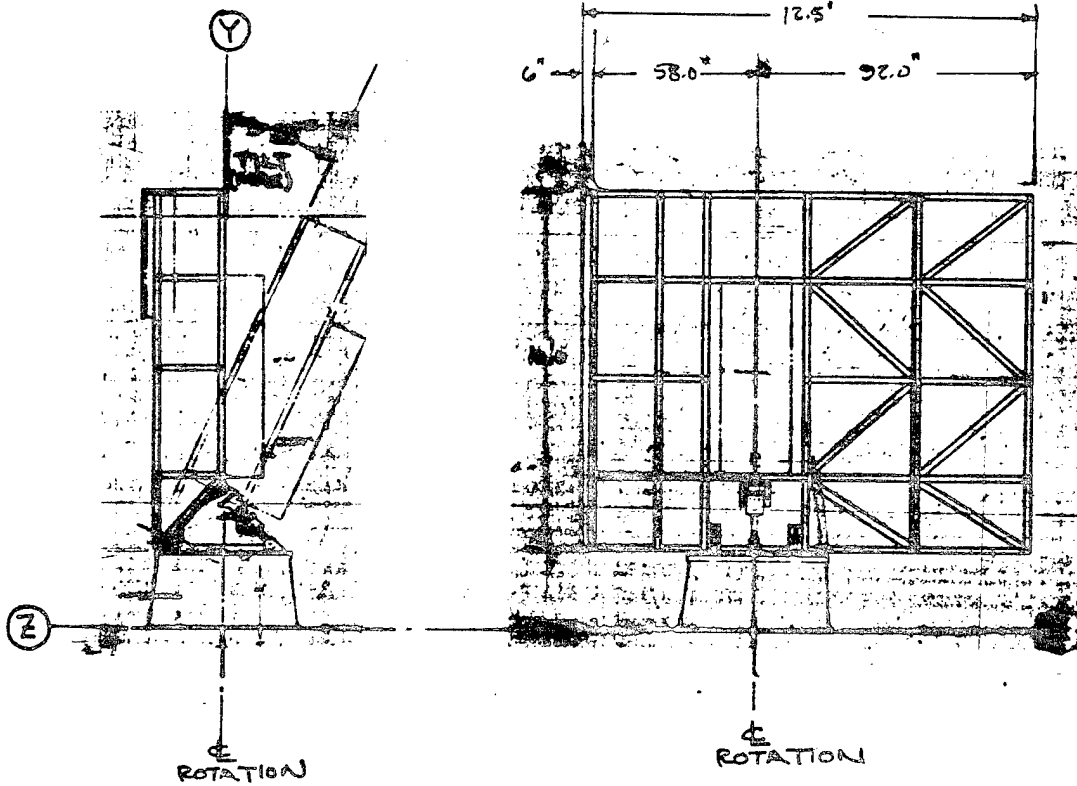
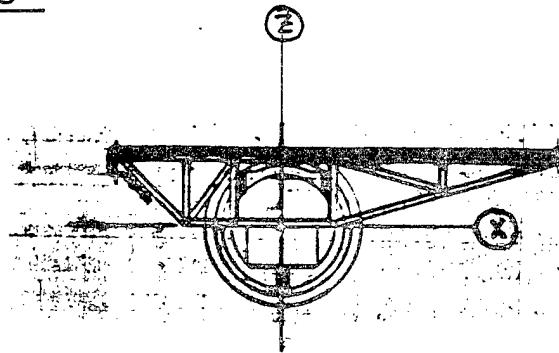

PEDESTAL-ANTENNA ASSEMBLY CONFIGURATION

PREPARED	NAME APD	DATE 1/30/73	ITT Gilfillan Inc.	SHEET 7 OF
CHECKED				TITLE PROJECTILE TRACKING RADAR STRUCTURES ANALYSIS
APPROVED				

MASS DISTRIBUTION ANALYSIS (CONT'D)

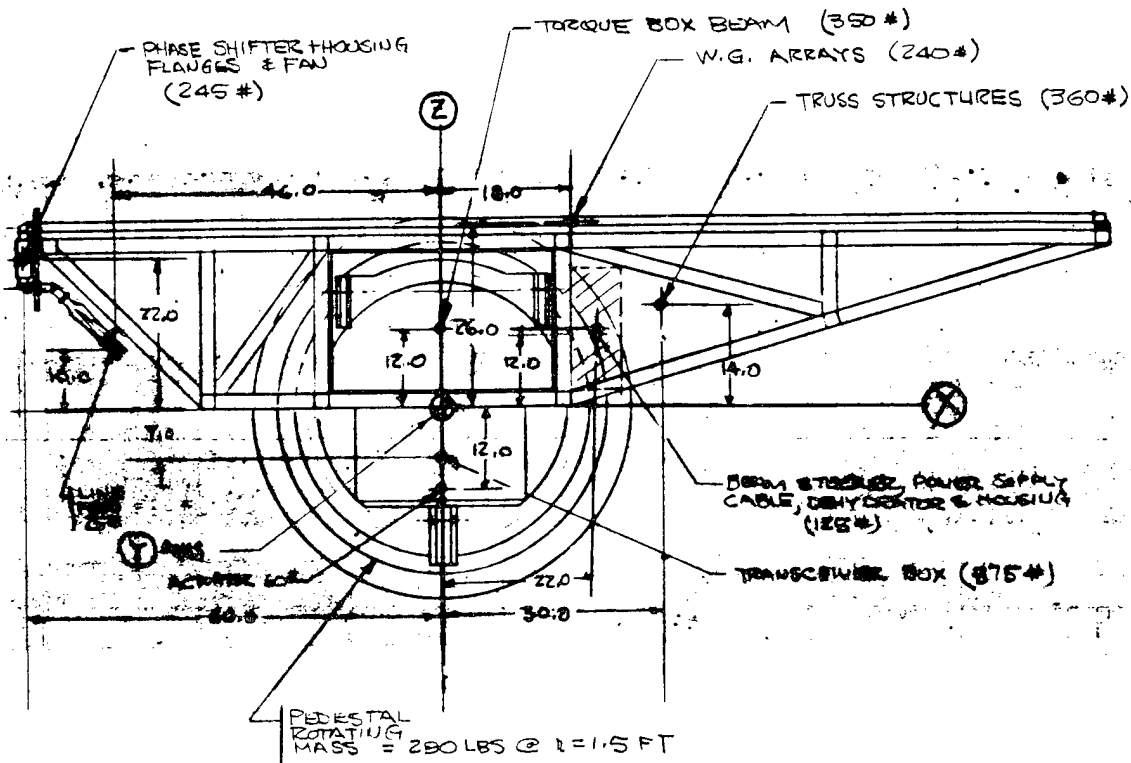

PLAN VIEW - MASS DISTRIBUTION

$$\bar{X} = \frac{-245 \times 60 - 25 \times 46 + 240 \times 18 + 360 \times 30 + 125 \times 22.0}{2070} = \frac{2020}{2070} = \underline{\underline{0.97 \text{ IN}}}$$

$$\bar{Z} = \frac{245 \times 22.0 + 25 \times 10 + 240 \times 26.0 + 350 \times 12.0 + 360 \times 14 + 125 \times 12.0 - 375 \times 7.0 - 60 \times 12.0}{2070}$$

$$R = \sqrt{\bar{Z}^2 + \bar{X}^2} = \frac{19270}{2070} = \underline{\underline{9.30 \text{ IN}}}$$

$$I_m)_{YY} = \frac{1}{32.2} \left[ 245(639)^2 + 25(47)^2 + 60(12.0)^2 + 375(7.0)^2 + 350(12)^2 + 290(18)^2 + 125(25)^2 + \frac{360(144)^2}{12} + 360(33)^2 + \frac{240(180)^2}{12} + 240(31.5)^2 \right] \frac{1}{144} = \frac{3.012 \times 10^6}{32.2 \times 144}$$

$I_m)_{YY} = 650.0 \text{ #-FT SEC}^2$

PREPARED	NAME JPD	DATE 1/31/73	ITT Gilfillan Inc.	SHEET 8 OF
CHECKED			TITLE PROJECTILE TRACKING RADAR	SKETCH NO.
APPROVED			STRUCTURES ANALYSIS	

STRUCTURES ANALYSIS

WIND LOAD

$$A = 12.5 \times 10.0 = 125 \text{ FT}^2$$

$$C_D = 1.30$$

$$q_0 = 2.52 \text{ PSF}$$

$$q_s = 18.85 \text{ PSF}$$

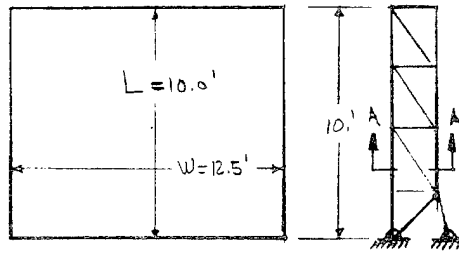

DRAG LOAD

$$F_D = C_D q_0 A = 1.30 \times 2.52 \times 125 = \underline{\underline{410 \text{ LBS}}}$$

$$F_S = C_D q_s A = 1.30 \times 18.85 \times 125 = \underline{\underline{3070 \text{ LBS}}}$$

TORQUE LOAD

$$T_{WL} = C_E W q_0 A \quad \text{where } C_E = 0.15$$

$$= 0.15 \times 12.5 \times 2.52 \times 125$$

$$T_{WL} = \underline{\underline{590.0 \text{ FT-}\#}}$$

$q_0 = 2.52 \text{ PSF @ 30 MPH}$

TORQUE BOX-BEAM ANALYSIS

- REF P(1) LET ERROR TORQUE TUBE  $\cong$  25% OF MECH. ERROR ( $E_m$ )
- (a)  $E_{tt} \cong .25 \times .50 = .125 \text{ M.R}$
  - (b)  $\alpha = 0.70 \text{ RAD/SEC}^2$
  - (c)  $(I_m)_y = 650.0 \text{ }\# \text{-FT SEC}^2$

TOTAL TORQUE LOAD ON TUBE

$$T_T = I_m \alpha + T_{WL} = 0.70 \times 650 + 590.0$$

$$T_T = \underline{\underline{1045.0 \text{ FT-}\#}} \quad \text{MAXIMUM TORQUE REQ'D, AT ANTENNA}$$

TORSIONAL STIFFNESS (K) OF TUBE

CLOSED RECTANGULAR SECTION

$$K = \frac{2t b^2 a^2}{(a+b)} = \frac{2 \times .25 (24)^2 (32)^2}{(24+32)}$$

$$K = \underline{\underline{5266.0 \text{ IN}^4}}$$

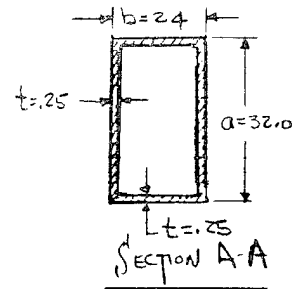

PREPARED	NAME AFD	DATE 1/31/73	ITT Gilfillan Inc.	SHEET 9 OF
CHECKED		TITLE PROJECTILE TRACKING RADAR		SKETCH NO.
APPROVED		STRUCTURES ANALYSIS		

TORQUE BOX-BEAM ANALYSIS (CONT'D)

SOLVE FOR ANGULAR TORSION " $\theta_{tt}$ "

$$\theta_{tt} = \frac{T L}{K G}$$

where:  $T_T = 1045 \times 12 \text{ IN-LB}$   
 $G = 3.8 \times 10^6 \text{ PSI (ALUMINUM)}$   
 $L = 120.0 \text{ IN}$   
 $K = 5266.0 \text{ IN}^4$

$$= \frac{1045 \times 12 \times 120}{5266.0 \times 3.8 \times 10^6}$$

$$\epsilon_{tt} = \theta_{tt} = 0.075 \times 10^{-3} \text{ RAD} = \underline{0.075 \text{ M.R.}} \ll \epsilon_{tt} = .125 \text{ O.K.}$$

BENDING DEFLECTION & ROTATION OF TUBE

AT 20 MPH WIND  
 CONSIDER TUBE CANTILEVERED @ (B)-(B)  
 UNIFORMLY LOADED

$$\Delta_T = \frac{W L^3}{8 E I_{xx}} = \frac{410 (120)^3}{8 \times 10^7 \times 2800}$$

$W = F_0 = 410^*$

$$\Delta_T = \underline{0.0032 \text{ IN}}$$

ANGULAR ROTATION  $\theta_b$

$$\theta_b = \epsilon_b = \frac{W L^2}{6 E I} = \frac{410 (120)^2}{6 \times 10^7 \times 2800}$$

$$\epsilon_b = \underline{0.035 \text{ M.R.}}$$

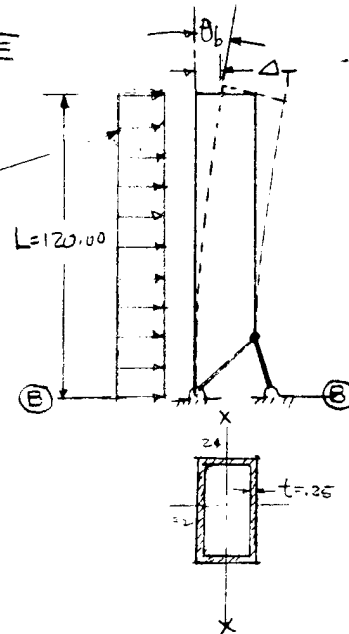

TILTING SCREW ACTUATOR ANALYSIS

THE ACTUATOR WILL BE A DUFF-NORTON  
 SCREW ACTUATOR MODEL # 1810 RATED  
 AT 10 TON. THE LIFTING SCREW IS  
 A 2.00 INCH DIA. WITH A .50 INCH  
 PITCH SQUARE THREAD. THE ERECTED  
 LENGTH OF THE SCREW IS

$$L_{eff} = 19.50 \text{ INCHES}$$

CALCULATE LOADS ON ACTUATOR & TRUNNIONS

$$I_{xx} = \frac{1}{12} [24^3 \times 30 + 23.5^3 \times 31.5]$$

$$\underline{I_{xx} = 2800 \text{ IN}^4}$$

PREPARED	NAME APD	DATE 1/31/73	 <b>Gilfillan Inc.</b>	SHEET 10 OF
CHECKED		TITLE PROJECTILE TRACKING RADAR		SKETCH NO.
APPROVED		STRUCTURES ANALYSIS		

ANTENNA TRUNNION PIVOT & ACTUATOR ANALYSIS

THE TRUNNION PIVOTS & ACTUATOR ARE ANALYZED FOR LOAD AS FOLLOWS:

(a) WIND LOAD  $F_0 = 410 \pm$  (OPERATING)  
(ERECT CONDITION)  $F_0 = 3070 \#$  (SURVIVAL)

(b) RAILROAD IMPACT LOAD  
AT  $\Pi_y = \Pi_z = 20g's$

OPERATING CONDITION

$$\Sigma M_{RP} = 0$$

$$60F_0 + 1720 \times 6.7 = 32.0 \left[ \frac{20.0 P_{ACT}}{(20.0 + 17.3)} \right]$$

$$P_{ACT} = \frac{(60 \times 410 + 1720 \times 6.7) 26.44}{32.0 \times 20.0}$$

$$P_{ACT} = 1500 \text{ LBS}$$

SURVIVAL CONDITION

$$\Sigma M_{RP} = 0$$

$$P_{ACT} = \frac{(60 \times 3070 + 1720 \times 6.7) (26.44)}{32.0 \times 20.0}$$

$$P_{ACT} = 8090 \text{ LBS}$$

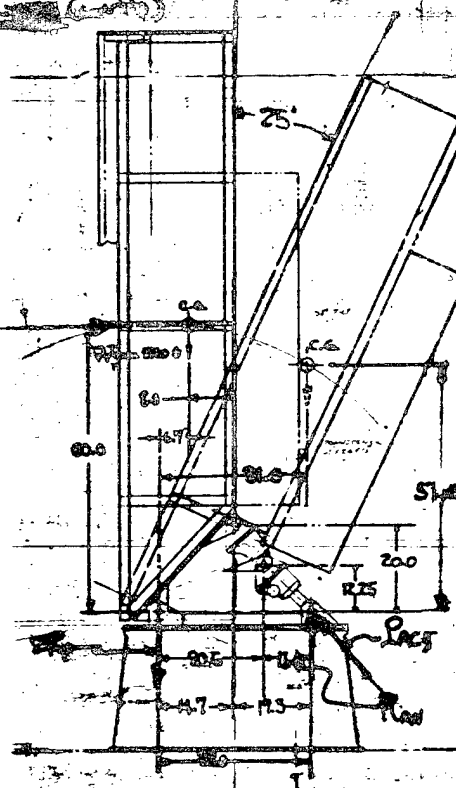

RAILROAD IMPACT LOAD  $\Pi_z = \Pi_y = 20g's$  (25° TILT)

$$\Pi_z = 20g's \quad P_{ACT} = 0.0$$

$$R_P = \frac{W_n \times 51 (\Pi_z)}{24.0} = \frac{1720 \times 51 \times 20}{24.0} = 73,000 \text{ LBS}$$

$$\Pi_y = 20g's$$

$$P_{ACT} = \frac{31.0 \times W_n \Pi_y (11.45 + 12.25)}{32.0 \times 12.25} = \frac{31.0 \times 1720 \times 20 \times 16.76}{32.0 \times 12.25}$$

$$* P_{ACT} = 45,600 \text{ LBS}$$

\* BASED ON THESE CALCULATED LOADS ON TRUNNION & ACTUATOR, STOWAGE BARS ARE REQUIRED DURING RAIL ROAD SHIPMENT OF ANTENNA ASSEMBLY.

PREPARED	NAME ATB	DATE 1/31/73	ITT Gilfillan Inc. TITLE PROJECTILE TRACKING RADAR STRUCTURES ANALYSIS	SHEET 11 OF
CHECKED				SKETCH NO.
APPROVED				

SCREW ACTUATOR ELONGATION OR CONTRACTION

ACTUATOR SCREW, SQUARE THREAD

$$D_o = 2.00 \text{ IN}$$

$$D_r = 1.612 \text{ IN}$$

$$L_{eff} = 19.5 \text{ IN}$$

$$E = 29 \times 10^6 \text{ PSI}$$

$$P_{ACT} = 1500 \text{ LBS}$$

$$A_r = \frac{\pi}{4} (1.612)^2 = 2.05 \text{ IN}^2$$

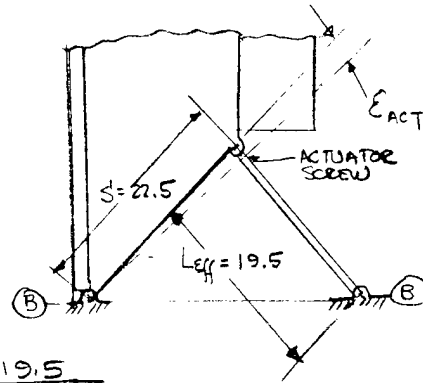

ANGULAR ERROR (E\_ACT) ELEVATION

OPERATING CONDITION

$$\Delta_{ACT} = \frac{P_{ACT} L_{eff}}{A_r E} = \frac{1500 \times 19.5}{2.05 \times 29 \times 10^6}$$

$$\Delta_{ACT} = .00048 \text{ IN}$$

$$E_{ACT} = \frac{\Delta_{ACT}}{S} = \frac{.00048}{22.5} = 0.02 \text{ M.R.}$$

CHECK BUCKLING

CONSIDER SCREW LENGTH FIXED AT ONE END

$$P_{CR} = \frac{\pi^2 E A_r}{4 \left(\frac{L_{eff}}{r}\right)^2} \quad \text{where } r = \frac{D_r}{4} = 1.612/4 = .403$$

$$P_{CR} = \frac{(3.14)^2 \times 29 \times 10^6 \times 2.05}{4 \left(\frac{19.5}{.403}\right)^2} = 62,600 \text{ LBS OK}$$

AZIMUTH BEARING ANGULAR ROTATION (ELEV) (E\_BRG)

$$k_{BRG} = 5.5 \times 10^8 \text{ IN-# / RADIAN}$$

$$M_{BRG} = F_0 \times 60 = 410 \times 60 = 24600 \text{ IN-#}$$

$$E_{BRG} = \frac{M_{BRG}}{k_{BRG}} = \frac{24,600}{5.5 \times 10^8} = 45.0 \times 10^{-6} \text{ RADIAN}$$

$$E_{BRG} = 0.045 \text{ M.R.}$$

PREPARED	NAME J. Zee	DATE 7/25/73	<b>ITT Gilfillan Inc.</b>	SHEET 12 OF
CHECKED			TITLE ARBAT COMBINED STRUCTURAL LOADING	SKETCH NO. PHASE B
APPROVED				

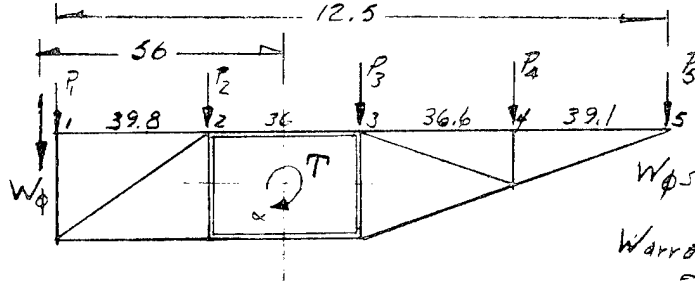

$$W_{\phi \text{ shifter}} = \frac{322}{3} = 107.6$$

$$W_{\text{array}} = \frac{270}{3(12.5)} = 7.5 \#/\text{FT}$$

$$W_{\text{struct}} = \frac{420}{3(12.5)} = 11.7 \#/\text{FT}$$

Wind load -  $F_0 = 410 \text{ lb}$  OPERATING  $F_3 = 7.5$   
 $F_5 = 3070$  SURVIVAL  $F_0$

$$W_0 = \frac{F_0(1)}{3(12.5)} = \frac{410}{3(12.5)} = 11 \#/\text{FT}$$

JOINT LOADS DUE TO WIND

$$P_1 = \frac{3}{2}(11) = 16.5 \#$$

$$P_2 = P_3 = P_4 = 3(11) = 33 \#$$

$$P_5 = \frac{3}{2}(11) = 16.5 \#$$

JOINT LOADS DUE TO ACCELERATION  $\alpha = 0.7 \text{ rad/sec}^2$

$$F = ma = \frac{W}{g} r \alpha = .02174 W r$$

$$F_1 = [W r + (7.5 + 11.7) \left(\frac{56}{2}\right)] .02174 = [107(56) + 19.2(1.5)52] \frac{.02174}{12} = 13.6 \#$$

$$F_4 = 19.2(3) \left(\frac{.02174}{12}\right) 52 = 5.4 \#$$

$$F_5 = 19.2 \left(\frac{3}{2}\right) \left(\frac{.02174}{12}\right) 88 = 3.58 \#$$

PREPARED	NAME S. EHE	DATE 7/25/73	ITT Gilfillan Inc.	SHEET 13 OF
CHECKED		TITLE COMPUTER MODEL FOR STRUPAK ANALYSIS		SKETCH NO. PHASE B
APPROVED				

COMPUTER MODELS STRUPAK PROGRAM 2DTSAP

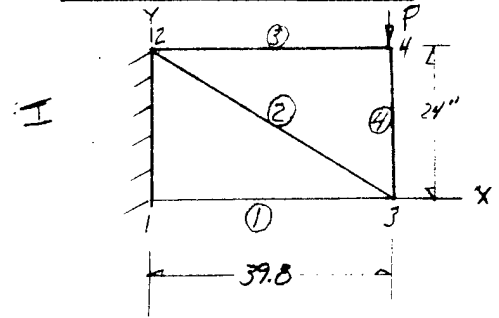

$$P_4 = 16.5 + 13.6 = 30.1 \text{ lb}$$

DEFLECTION RESULTS

$$\Delta_y = .000979 \text{ IN}$$

$$E_{H_4} = \frac{.000979 \times 1000}{39.8} = .025 \text{ mr}$$

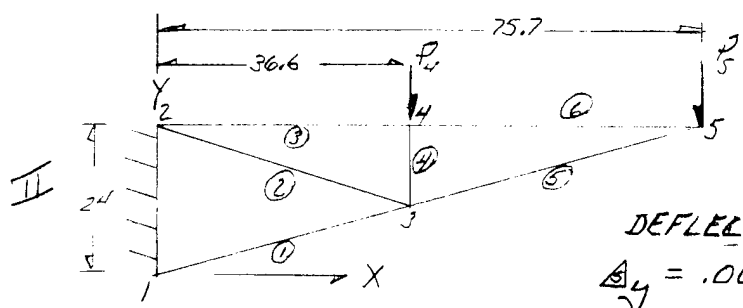

$$P_4 = 33 + 5.4 = 38.4 \text{ lb}$$

$$P_5 = 16.5 + 3.6 = 20.1 \text{ lb}$$

DEFLECTION RESULTS

$$\Delta_y = .004122 \text{ IN}$$

$$E_{H_5} = \frac{.004122 (1000)}{75.7} = .054 \text{ mr}$$

ASSUME CENTER SECTION TORQUE BOX TO BE RIGID & DEFLECTIONS ARE DUE TO BENDING OF TRUSS STRUCTURE ONLY

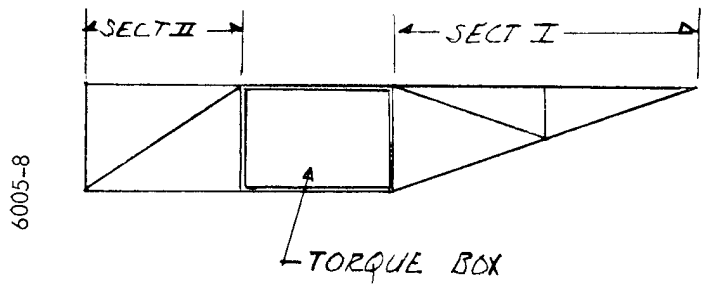

6005-8

PREPARED	NAME APD	DATE 2/1/73	<b>III Gilfillan Inc.</b>	SHEET 15 of
CHECKED			TITLE PROJECTILE TRACKING RADAR STRUCTURES ANALYSIS	SKETCH NO.
APPROVED				

ANTENNA-VEHICLE STRUCTURES ANALYSIS

INTRODUCTION: THE ANTENNA-PEDestal ASSEMBLY WEIGHING APPROX. 3000 LBS WILL BE MOUNTED RIGIDLY TO THE CENTER TRAILER CHASSIS AS SHOWN BELOW. FOUR (4) MAIN JACKS WILL RAISE THE SPRUNG MASS OF THE ANTENNA VEHICLE ASSEMBLY. A FIFTH JACK FOR ADDED STABILITY IS LOCATED AT THE TAIL END OF TRAILER.

THE DESIGN CRITERIA IS A ROTATIONAL OR A BENDING ANGULAR DEVIATION OF

$$\underline{\underline{E_{\theta} + t_{\theta}} = 0.25 \text{ MILLI RADIAN (REF. SHT 1)}}$$

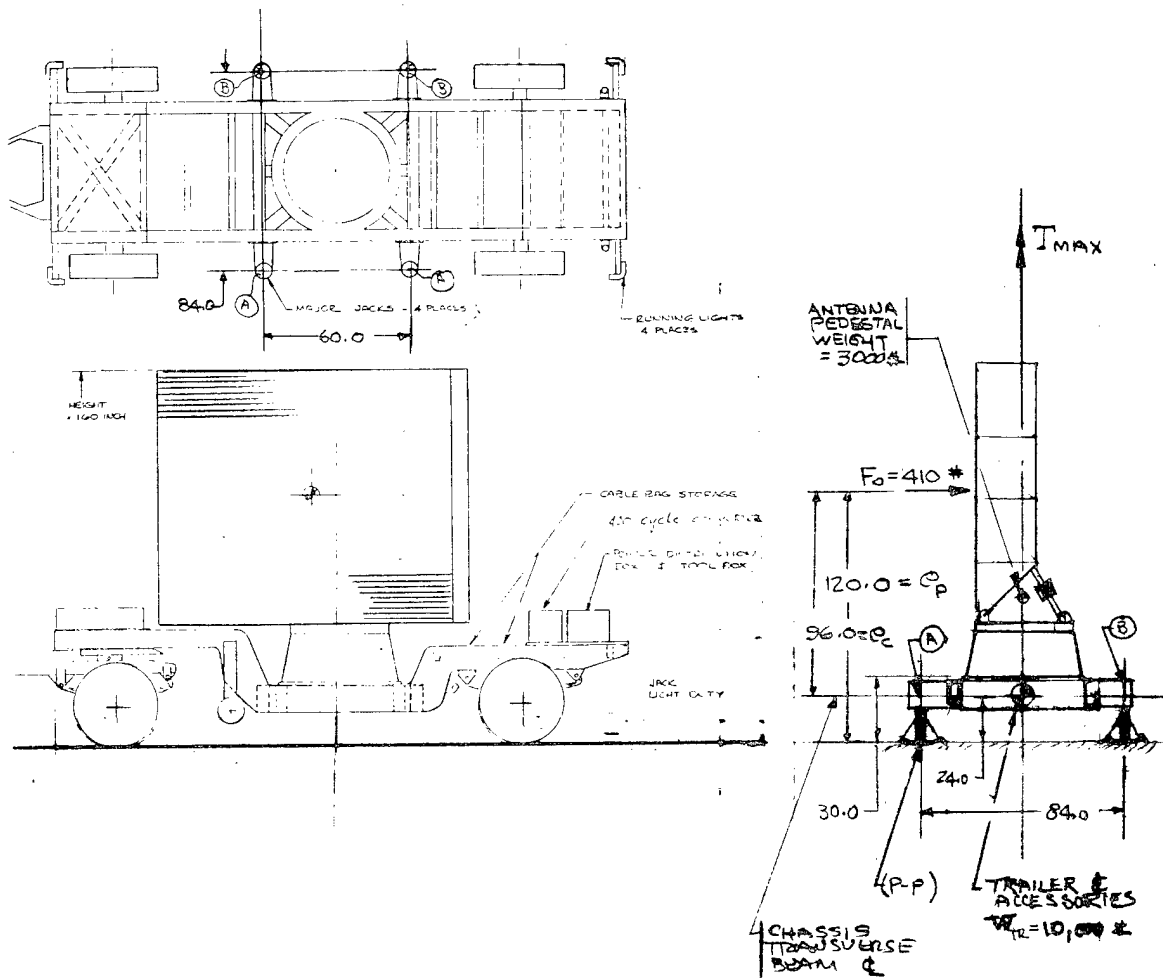

PREPARED	NAME AFS	DATE 2/1/73	ITT Gilfillan Inc.	SHEET 16 OF
CHECKED			TITLE PROJECTILE TRACKING RADAR	SKETCH NO.
APPROVED			STRUCTURES ANALYSIS	

ANTENNA-VEHICLE STRUCTURES ANALYSIS (CONT'D)

ANALYSIS PARAMETERS

$q_0 = 2.52 \text{ PSF @ 30 MPH (OPERATING)}$

$q_s = 18.85 \text{ PSF @ 75 MPH (SURVIVAL)}$

$C_D = 1.30$

$A_{WT} = 125 \text{ FT}^2$

$F_0 = C_D q_0 A = 1.30 \times 2.52 \times 125$

$F_0 = 410 \text{ LBS}$

$F_s = C_D q_s A = 1.30 \times 18.85 \times 125$

$F_s = 3070 \text{ LBS}$

$T_T = T_{MAX} = 1045. \text{ FT-}\#$

$E_{(jtr)} = 0.25 \text{ MILLIRADIANS}$

CHASSIS TRANSVERSE BEAM STIFFNESS DETERMINATION

INCLUDING JACK EXTENSION BEAM

$M_0/\text{BEAM} = F_0 \times e_c / 2 = 410 \times \frac{96}{2} = 19,680 \text{ IN-}\# / \text{BEAM}$

$e_c = E_{(jtr)} = 0.25 \times 10^{-3} = \frac{M_0 L}{12EI}$

$I = \frac{19,680 \times 84}{12 \times 0.25 \times 10^{-3} \times 30 \times 10^6} = 18.40 \text{ IN}^4$

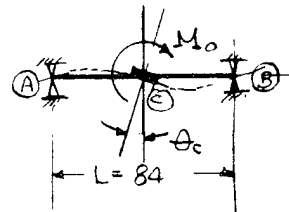

USE AISC 6.0 X 3.0 RECT. TUBING  $t = 3/8$

CHECK FOR STRESS AT SURVIVAL

$M_{LL} = M/\text{BEAM} = F_s e_c / 2 = 3070 (\frac{96}{2})$   
 $= 147,400 \text{ IN-}\#$

$\sigma_b = \frac{M e}{I_x} = \frac{147,400 \times 3.0}{22.7}$

$\sigma_b = 19,480 \text{ PSI}$

$MS)_y = \frac{36,000}{19,480} - 1.0 = +0.85 \text{ (OK)}$

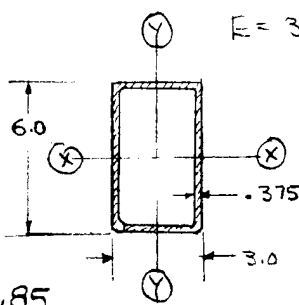

$E = 30 \times 10^6 \text{ PSI STEEL}$

$I_{XX} = 22.7 \text{ IN}^4$

$I_{YY} = 7.51 \text{ IN}^4$

$F_{TY} = 36 \text{ KSI}$

REF: AISC MANUAL  
7th EDITION  
P. 3.47

PREPARED	NAME APB	DATE 2/1/73	 TITLE PROJECTILE TRACKING RADAR STRUCTURES ANALYSIS	SHEET 14 OF
CHECKED				SKETCH NO.
APPROVED				

FRONT TRUNNION PILOT ANALYSIS

THE TRUNNIONS ARE DESIGNED FOR LOADS UNDER RAILROAD IMPACT LOAD. THE LOAD PER TRUNNION (REF. SHEET 10) WAS PREVIOUSLY CALCULATED TO BE

$$R_p = 73,000 \text{ LBS}$$

PRE-LIMINARY DESIGN

LET  $D_p = 1.50 \text{ IN}$  BASIC PIN DIAMETER INCLUDING BRG. BUSHINGS  
 $L_{eff} = 2.00 \text{ IN}$  BRG. LENGTH  
 $A_{BRG} = 3.00 \text{ IN}^2$

BEARING STRESS

$$\sigma_{BRG} = \frac{R_p}{A_{BRG}} = \frac{73,000}{3.00} = 24,300 \text{ PSI}$$

FOR 6061-T6 CLEVIS BLOCK

$$F_{BRG} = 50,000 \text{ PSI}$$

$$MS = \frac{50,000}{24,300} - 1.0 = \underline{+1.14}$$

BENDING STRESS ON BOLT

ASSUMED UNIFORMLY DISTRIBUTED LOAD ON 2.00 IN SPAN  $1/4$  IN BOLT

$$S_b = \frac{\pi D_b^3}{32.0} = \frac{3.14 (1.25)^3}{32.0}$$

$$S_b = 0.192 \text{ IN}^3$$

$$\sigma_b = \frac{M}{S_b} = \frac{R_p L / 8}{S_b}$$

$$\sigma_b = \frac{73,000 \times 2.0}{8.0 \times 0.192} = \underline{95,000 \text{ PSI}}$$

USE 160-180,000 PSI BOLT

ULTIMATE STRENGTH

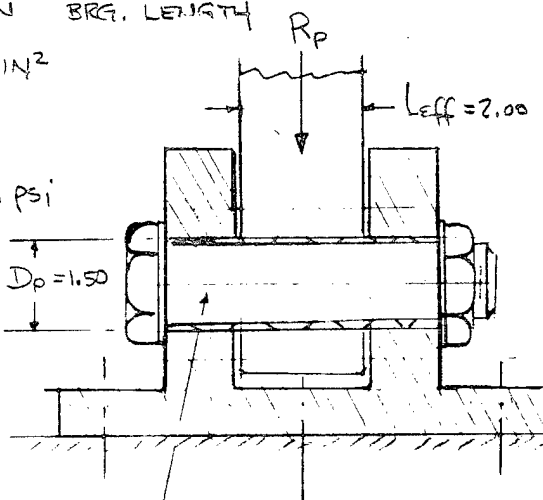

$1/4$  DIA. BOLT WITH ADJUSTABLE BUSHINGS.

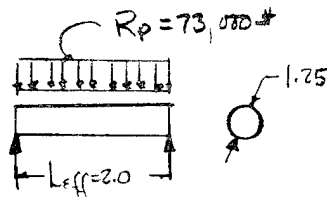

PREPARED	NAME APD	DATE 2/1/73	<b>TIT Gilfillan Inc.</b> TITLE PROJECTILE TRACKING RADAR STRUCTURES ANALYSIS	SHEET 17 OF
CHECKED				SKETCH NO.
APPROVED				

## ANTENNA-VEHICLE STRUCTURES ANALYSIS

### CHASSIS TRANSVERSE BEAM (CONT'D)

INCLUDE DL =  $3000\#/2 = 1500\#$   
 ASSUMED CONC. AT CENTER

$$M_{DL} = 1500 \times 84/4 = 31,500 \text{ IN-}\#$$

$$M_{LL} = F_s c c/2 = 147,000 \text{ IN-}\#$$

$$M_T = 178,500 \text{ IN-}\#$$

$$\sigma_b = \frac{M_T \cdot c}{I_{xx}} = \frac{178,500 \times 3.0}{22.7}$$

$$\underline{\underline{\sigma_b)_{max} = 23,600 \text{ PSI} < F_{TY} \text{ OK}}}$$

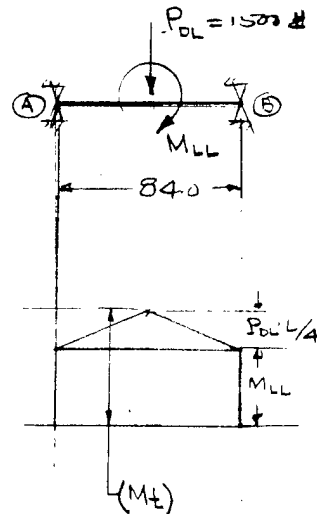

### DYNAMIC LOADING ON FRAME

$$n = 10 \text{ g's}$$

$$\therefore M_{DL} = 1500 \times 84/4 \times 10 = 315,000 \text{ IN-}\#$$

$$\sigma_b)_{max} = \frac{315,000 \times 2.5}{15.5} = \underline{\underline{50,800 \text{ PSI}}} \gg F_{TY} \text{ HIGH (NG)}$$

$$\text{FOR } F.S. = 1.50, \sigma_b)_{ALL} = \frac{36,000}{1.5} = 24,000$$

$$I_{REQ} = \frac{315,000 \times 3.0}{24,000} = \underline{\underline{39.4 \text{ IN}^4}} \text{ FOR } 6.0'' \text{ SQ. TUBING}$$

USE AISC

**6x6 x 3/8 SQ. STRUCTURAL TUBING**

$$\underline{\underline{I_{xx} = I_{yy} = 40.5 \text{ IN}^4}}$$

$$\therefore \theta_c = (\epsilon_{tr}) = \frac{M_o L}{12EI} = \frac{19,680 \times 84}{12 \times 40.5 \times 30 \times 10^6} = .000113 \text{ RAD}$$

$$\underline{\underline{(\epsilon_{tr}) = 0.113 \text{ MILLIRADIAN}}}$$

(ELEVATION DIRECTION)

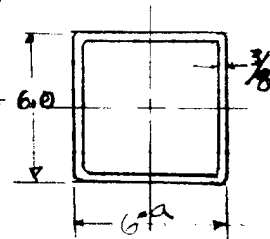

PREPARED	NAME A.P.O.	DATE 2/1/73	<b>ITT Gilfillan Inc.</b>	SHEET 18 OF
CHECKED			TITLE PROJECTILE TRACKING RADAR STRUCTURES ANALYSIS	SKETCH NO.
APPROVED				

JACK STRUCTURE TORSIONAL & BENDING ROTATION

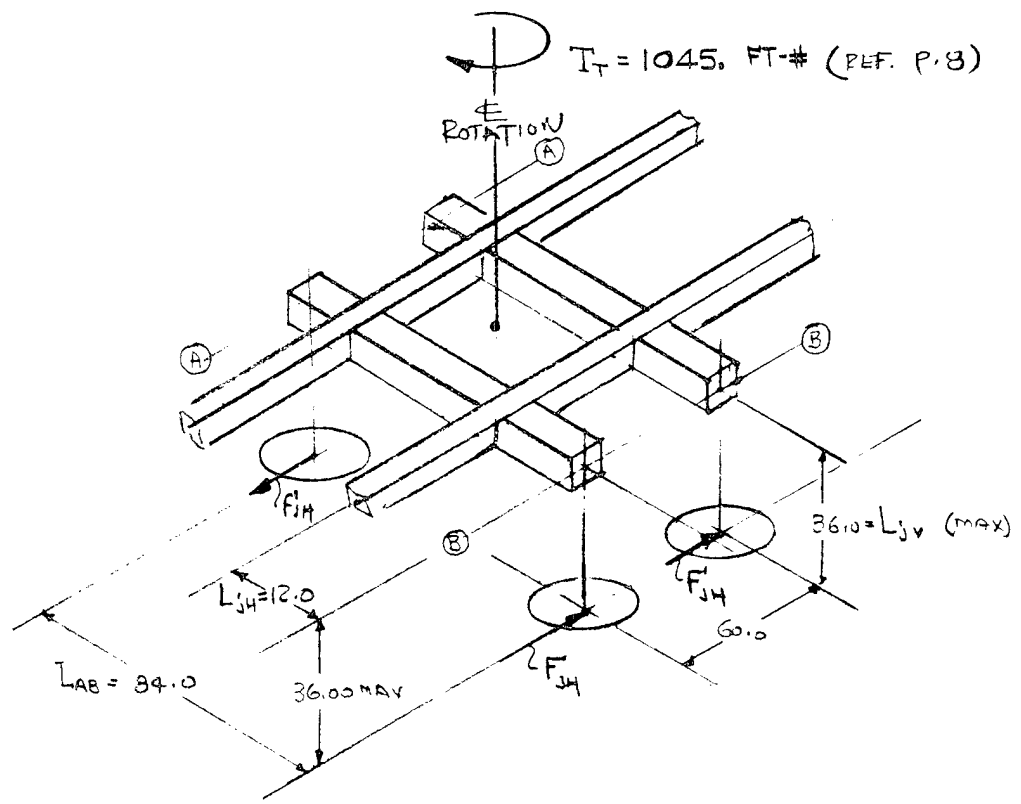

JACK SHEAR REACTION (F<sub>JH</sub>) (OPERATING CONDITION)

$$F_{JH} = \frac{T_T}{2L_{AB}} = \frac{1045 \times 12}{2 \times 84} = \underline{75.0 \text{ LBS}}$$

CHASSIS TRANSVERSE BEAM (A-B) WAS PREVIOUSLY SIZED TO BE 6X6 X 3/8 AISC TUBING.

SOLVE FOR TORSIONAL STIFFNESS OF LENGTH (L<sub>JH</sub>)

$d = 6.00 \text{ IN}$   
 $t = \frac{3}{8} \text{ IN}$   
 $K_j = d^3 t = 6^3 \times \frac{3}{8}$   
 $\underline{K_j = 81.00 \text{ IN}^4}$  POLAR MOMENT OF INERTIA  
 $\approx I_{xx} + I_{yy}$

PREPARED	NAME APD	DATE 2/1/73	<b>TIT Gilfillan Inc.</b>	SHEET 19 OF
CHECKED			TITLE PROJECTILE TRACKING RADAR	SKETCH NO.
APPROVED			STRUCTURES ANALYSIS	

JACK STRUCTURES TORSIONAL & BENDING ROTATION (CONT'D)

CONSIDER ONE JACK SUPPORT

$$T_j = F_{jH} \times L_{jV} = 75 \times 36.0$$

$$T_j = \underline{2700.00 \text{ IN}\cdot\#}$$

LET  $D_j = 6.00 \text{ IN (DIA)}$

$$t = \frac{3}{8} \text{ IN}$$

$$I_j = \frac{\pi D_j^3 t}{8} = 31.8 \text{ IN}^4$$

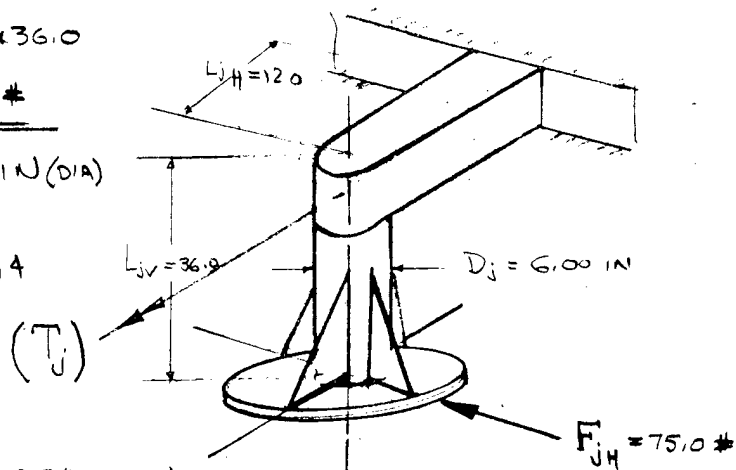

THE TOTAL ANGULAR DEVIATION ABOUT THE CENTER OF ROTATION IS GIVEN BY

$$\Phi = \epsilon_{j+tr} = \frac{\Delta L_{jH} + \Delta L_{jV} + \Phi_{jH} \times L_{jV}}{L_{jB}/2}$$

$$\Delta L_{jH} = \frac{F_{jH} L_{jH}^3}{3EI} = \frac{75.0 (12)^3}{3 \times 30 \times 10^6 \times 40.5} = .00003 \text{ IN}$$

( $I = 40.5 \text{ IN}^4$ )

$$\Delta L_{jV} = \frac{F_{jH} L_{jV}^3}{3EI_j} = \frac{75.0 (36)^3}{3 \times 30 \times 10^6 \times 31.8} = .00122 \text{ IN}$$

( $I = 31.8 \text{ IN}^4$ )

$$\Delta_j = \frac{T_j L_{jH} \times L_{jV}}{K_j G} = \frac{2700 \times 12.0 \times 36.0}{81.0 \times 11.5 \times 10^6} = .00124 \text{ IN}$$

$$G = 11.5 \times 10^6 \text{ psi}$$

$$\Delta_j]_{\text{TOTAL}} = \underline{.00249 \text{ IN}}$$

$$(\epsilon_{j+tr}) = \Phi = \frac{.00249}{84/2} \times 1000 = \underline{.059 \text{ MILLIRADIAN}} \ll \sum_{\text{ALL MR}} = 0.25 \text{ MR}$$

(AZIMUTH DIRECTION)

FROM THE ABOVE RESULTS A DIAMETRAL CLEARANCE (SLOP) ON THE JACK CAN BE TOLERATED TO A MAXIMUM OF

$$\Delta D = (.000025 - .000059) 42 = \underline{.00080 \text{ IN}}$$

$$\therefore \epsilon_{jcl} = 0.200 \text{ M.R.}$$

PREPARED	NAME AFD	DATE 2/1/73	ITT Gilfillan Inc.	SHEET 20 OF
CHECKED		TITLE PROJECTILE TRACKING RADAR		SKETCH NO.
APPROVED		STRUCTURES ANALYSIS		

ANTENNA-VEHICLE SYSTEM STABILITY - SURVIVAL COND.

REFERRING TO SKETCH ON P. 14 AND LOAD  $F_s$  ON P. 15 AND TAKING MOMENT ABOUT (P-P)

$$F_s = 3070.0 \text{ LBS}$$

$$e_p = 120.00 \text{ IN}$$

$$W_{\text{ANT-PED}} = 3000 \text{ LBS}$$

$$W_{\text{TR+AC}} \approx 10,000 \text{ LBS}$$

RESTRAINING MOMENT (RM)

$$RM = (W_{\text{A-P}} + W_{\text{TR+AC}}) L_{\text{AS}}/2$$

$$= 13,000 \times 42$$

$$RM = 546,000 \text{ IN-}\# = 45,500 \text{ FT-}\#$$

OVERTURNING MOMENT -(OM)

$$OM = F_s \times e_p$$

$$= 3070 \times 120$$

$$OM = 368,400 \text{ IN-}\# = 30,700 \text{ FT-}\#$$

$$\frac{RM}{OM} = \frac{546,000}{368,400} = 1.48$$

FOR A 13,000 LB ANTENNA-VEHICLE WEIGHT THE SYSTEM THEREFORE IS STABLE AND NEEDS NO EXTERNAL STOWAGE PROVISION.

PREPARED	NAME LPS	DATE 2/1/73	ITT Gilfillan Inc.	SHEET 21 OF	
CHECKED				TITLE PROJECTILE TRACKING RADAR	SKETCH NO.
APPROVED				STRUCTURES ANALYSIS	

### JACK PAD BEARING LOAD ANALYSIS

\* USE SURVIVAL LOAD ( $F_s$ ) ON ANTENNA

$$\sum M_{R_1} = 0$$

$$R_2 = \frac{F_s \cdot e_p}{2L} - \frac{W_f}{4}$$

$$= \frac{3070 \times 120}{2 \times 84} - \frac{13,000}{4}$$

$$= 2190 - 3250$$

$$R_2 = -1060 \text{ LBS} \quad \text{COMPRESSION ON SOIL}$$

$$\sum M_{R_2} = 0$$

$$R_1 = -2190 - 3250$$

$$R_1 = -5440 \text{ LBS} \quad \text{COMPRESSION ON SOIL}$$

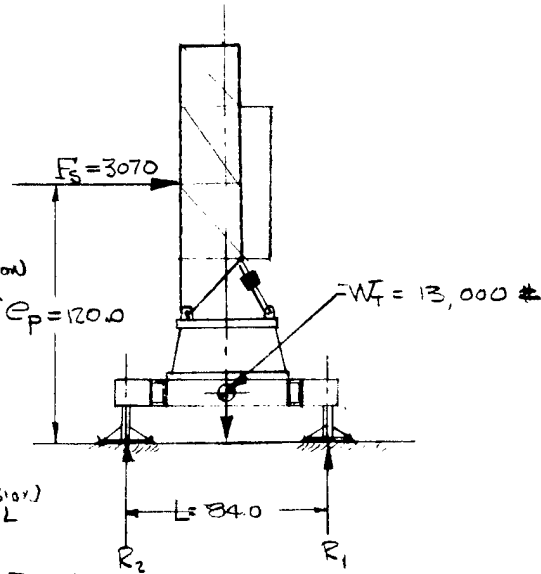

DESIGN JACK PAD FOOT PRINT BASE  
ON MAX. OPERATING BEARING  
LOAD OF \*  $P_{REQ} = 5000 \text{ LBS}$

\* DESIGN JACK FOR STON  
OR 10,000 LBS CAPACITY.

#### ASSUMPTION

- (1) USE MODULUS OF SUBGRADE REACTION  $K_u = 100 \text{ PSI/IN}$
- (2) LET MAXIMUM BEAR. LOAD  $\sigma_{ALL} = 1500 \text{ PSF}$  - WHICH WILL ALLOW THE SYSTEM TO OPERATE ON SOIL SUCH AS SOFT CLAY, CLAY LOAM, POORLY COMPACTED SAND, CLAY CONTAINING LARGE AMOUNT OF SILT & WATER STANDS DURING WET SEASON.

$$A_{PAD} = \frac{P_{REQ}}{\sigma_{ALL}} = \frac{5000}{1500} = 3.33 \text{ FT}^2 \quad (A_{PAD} = 3.14 \text{ FT}^2)$$

$$D_{PAD} = \sqrt{\frac{4 \times 3.3}{\pi}} = 2.06 \text{ FT} \quad \text{OR} \quad (D_{PAD} = 24.00 \text{ IN})$$

THE DIFFERENTIAL BEARING LIVE LOAD  $\Delta P_{LL} = 2190 \text{ LBS}$

$$\therefore \Delta_{DIFF} = \frac{\Delta P_{LL} / A_{PAD}}{K_u} = \frac{2190 / (3.14 \times 144)}{100} = 0.048 \text{ IN}$$

$$\epsilon_{PAD} = \frac{\Delta_{DIFF}}{L} \times 1000 = \frac{0.0480}{84.0} \times 1000$$

$$\epsilon_{PAD} = 0.570 \text{ MILLI RADIANS}$$

PREPARED	NAME B. ROE	DATE 10/5/76	ITT Gilfillan	SHEET 1 OF 1
CHECKED			TITLE PHASE B ANTENNA WEIGHTS	SKETCH NO.
APPROVED				

ANTENNA STRUCTURE	722.0
LINE FEED	45.5
ARRAYS (167)	235.5
MONITOR LINE	22.4
PHASE SHIFTERS (167)	167.0
PHASE SHIFTER HOUSING	45.3
COMBS	<u>26.0</u>
	1263.7 lb

WEIGHT OF ANTENNA SYSTEM DESIGNED &  
 FABRICATED UNDER PHASE B. THESE WEIGHTS  
 WILL BE UTILIZED IN PHASE C FOR  
 ANALYSIS & DESIGN OF SERVO DRIVE SYSTEM.

REPORT DISTRIBUTION

Required Distribution	<u>Number of Copies</u> <u>Reports</u>
	Final Tech Report DI-S-180
Commander Picatinny Arsenal ATTN: Technical Support Directorate SARPA-TS-T-S SARPA-TS-1	   5 1
Product Assurance Directorate SARPA-QA-A-R Dover, New Jersey 07801	 10
Project Manager Munitions Prod Base Mod & Exp Picatinny Arsenal ATTN: DRCPM-PBM Dover, New Jersey 07801	    1
Defense Documentation Center Cameron Station Alexandria, Virginia 22314	  12
Commander U. S. Army Materiel Development & Readiness Command ATTN: DRCRD-WC DRCRD-OS DRCQA-E Washington, D. C. 20315	   1 1 1
Commander U. S. Army Armament Command ATTN: DRSAR-QAE DRSAR-RD DRSAR-AS Rock Island, Illinois 61201	   3 1 1

Commander  
U. S. Army Electronics Command  
ATTN:  
DRSEL-CT-R 3  
Fort Monmouth, N.J. 07703

Commander  
U. S. Army Test & Eval. Command  
ATTN:  
DRSTE-RU 1  
Aberdeen, Maryland 21005

Commander  
U. S. Army Missile Command  
ATTN:  
Technical Library 1  
Redstone Arsenal, Alabama 35809

Commander  
Ballistic Research Laboratories  
ATTN:  
Technical Library 1  
Aberdeen Proving Ground  
Maryland 21005

Commander  
Harry Diamond Laboratories  
ATTN:  
DRXDO-TA 1  
Washington, D. C. 20438

Commander  
Frankford Arsenal  
ATTN:  
N3200 1  
Philadelphia, PA. 19137

Commander  
Aberdeen Proving Ground  
ATTN:  
STEAP-MT-G 1  
Aberdeen Proving Ground, Maryland  
21005

Commander  
Yuma Proving Ground  
ATTN:  
STEYP-MTS 1  
Yuma, Arizona 85634

Commander  
White Sands Missile Range  
ATTN:  
    Technical Library  
New Mexico 88002

1

Commander  
Jefferson Proving Ground  
ATTN:  
    STEJP-MTM  
Madison, Indiana 47521

1

Commander  
Naval Ordnance Systems Command  
ATTN:  
    Code ORD-0462D  
Washington, D. C. 20362

1

Director  
Naval Research Laboratories  
ATTN:  
    Technical Library  
Washington, D. C. 20390

1

Commander  
U. S. Naval Weapons Laboratory  
ATTN:  
    Technical Library  
Dahlgren, Virginia 22488

1

Commander  
U. S. Naval Ordnance Test Station  
ATTN:  
    Technical Library  
China Lake, California 93555

1

Commander Marine Corps  
Hq., U. S. Marine Corps  
ATTN:  
    Code A04C  
Washington, D. C. 20380

1

Commander  
Wright Air Development Division  
Wright-Patterson Air Force Base  
ATTN:  
    Technical Library  
Ohio 45433

1

Commander  
Rome Air Development Command  
Griffiss Air Force Base  
ATTN:  
    Technical Library 1  
New York 13440

Commander  
Air Force Rocket Propulsion Lab (AFSC)  
ATTN:  
    Mr. L. Meyers (RPMMA) 1  
Edwards Air Force Base  
California 93523

Commander  
ADTC (ADLEG)  
ATTN:  
    Mr. J. Howanick 1  
Eglin Air Force Base  
Florida 32542

Commander  
Service Engineering Division (MME)  
ATTN:  
    Mr. D. Hebdon (MMECL) 1  
Hill Air Force Base, Utah 84401



Block No. 20 (Continued)

rotation of the array. Development steps included fabrication and testing of individual critical items and assemblies of critical items to estimate full array performance. A 9 element partial array was range tested prior to fabrication of the required 167 horizontal array elements and associated microwave elements. The mechanical and electrical design is discussed and test results are summarized.