



Department of Biology

Woods Hole Oceanographic Institution

Woods Hole, MA 02543 USA

Phone: (508) 457-2000

Fax: (508) 457-2169

Telex: 951679

August 5, 1997

Dr. R. Tipper
Program Officer
ONR
800 N. Quincy Street
Arlington, VA 22217-5660

Dear Dr. Tipper:

On behalf of Dr. Peter H. Wiebe and Dr. Timothy K. Stanton, please find enclosed three copies of a final report for the DURIP Grant No. N00014-95-1102.

If there is anything further which you require, please let me know.

Sincerely,

Jane E. Marsh
Senior Staff Assistant
Biology Department

xc: S. Ferreira, WHOI, Grant & Contract Services
T. Austin, WHOI, AOPE Department
T. Stanton, WHOI, AOPE Department
K. Prada, WHOI, AOPE Department
R. Arthur, WHOI, AOPE Department
C. Greene, Cornell University
R. Tipper, Program Officer, ONR (3)
Administrative Grants Officer, ONR
Director, NRL
DTIC, Ft. Belvoir, VA (2)
ONR, Boston (1)

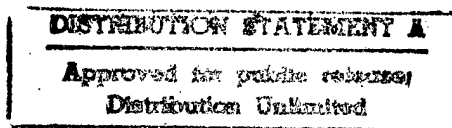

DTIC QUALITY INSPECTED 2

FINAL REPORT

ONR DURIP GRANT NO. N00014-95-1-1102

A High Performance Towed Platform for Bio-Optical,
Acoustical and Physical Data Acquisition

Peter H. Wiebe, Timothy K. Stanton and Tom Austin

Woods Hole Oceanographic Institution, Woods Hole, Massachusetts 02543

DISTRIBUTION STATEMENT A

Approved for public release;
Distribution Unlimited

19970820 159

DTIC QUALITY INSPECTED 3

INTRODUCTION

A towed system capable of conducting both field verification studies of theoretical plankton reverberation models and quantitative surveys of the spatial distribution of coastal and oceanic plankton/nekton, near surface bubble fields, and turbulence has been assembled and has undergone initial field testing. The system, known as the BIO-Optical Multi-frequency Acoustical and Physical Environmental Recorder or BIOMAPER II, consists of a multi-frequency sonar (ABSS), a video plankton recorder system (VPR), and an environmental sensor package (ESS) whose principal components are deployed on a body that is towed behind or along side a ship (Figure 1). Also included are an electro-optic tow cable; a winch with slip rings; and van which holds the electronic equipment for real-time data processing and analysis. The towbody is capable of operating to a depth of 300 meters at low towing speeds, while near the surface it may be towed at speeds up to 10 knots. The system operates in a surface towed down-looking mode, in a vertical oscillatory "towyo" mode, or in a sub-surface up/down looking horizontal mode. The latter modes will permit acoustical measurements close to the surface and over greater range of depths, especially at the higher frequencies. The towyo mode can be used to ensure that sufficient data are obtained to evaluate the range dependent bias against acoustically observed small targets located in dense layers or far from the transducer. This information can be gathered by lowering the towed body obliquely to within a few meters of the sea floor to obtain a profile of target strength distributions as a function of depth. Furthermore, towyoing ensures that all environmental and video data can be collected for all depths in the transects.

The tow cable consists of a strength member with optical fibers inside for data transmission and communication between the underwater portion of the system and the ship-board data logging and processing computers. The computers will ultimately produce acoustical and optical "maps" of the volume scattering distributions. The acoustic data can be presented both in raw form (i.e., volume scattering strength, with no assumptions) and in the form of size distributions of individual targets. The latter requires the use of scattering models, inverse techniques, and occasional samples of animals for use in the inversions. The optical/video data will be viewable in real-time, but currently, post processing is required to acquire the data for quantitative comparison with the acoustics. The system is

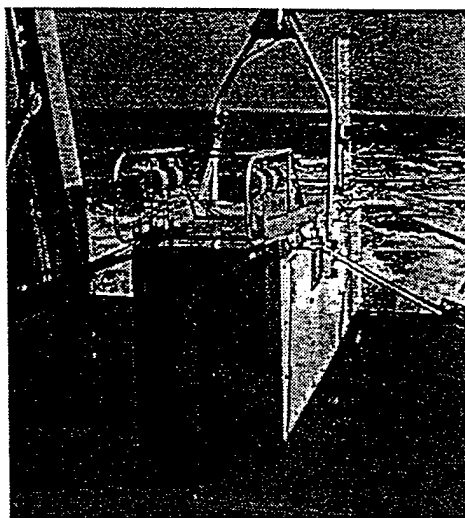

Figure 1. BIOMAPER II on the deck of the Diane G at the end of the test and evaluation cruise (15-18 July 1997).

524

designed for work in nearshore coastal regions with a working depth of 300 meters. It could be modified for work at much greater operating depths with modifications to the pressure housings for sensors and underwater electronics housings.

DESCRIPTION OF THE SYSTEM

The BIOMAPER system consists of three main subassemblies: the Towbody, Control Van, Tow Cable and Winch. The primary towbody sensors are the Acoustic Backscatter Sonar System (ABSS), Video Plankton Recorder (VPR), and the Environmental Sensor System (ESS). The ABSS was built by Hydroacoustics Technology Inc. Seattle, WA and the VPR and ESS were supplied by SeaScan Inc. Falmouth, MA. The entire system is self sufficient, in that it may be operated off of ships of opportunity, with electrical power and a towing frame being the only ship supplied requirements. All data acquisition and processing surface consoles are installed in the BIOMAPER II Control Van. The van has seating for five individuals and computers for four operations: ABSS Data Acquisition, ABSS Processing, ESS acquisition, and Hardware monitoring. Video monitors and a VCR are rack mounted for the VPR and for the two deck cameras (one observing the winch, and the other observing launch and recovery and tether angle).

The overall design philosophy of the system is to provide for simple low cost assembly, high reliability, and ease of maintenance and modification at sea.

The Vehicle.

BIOMAPER II is nearly identical to the proto-type BIOMAPER (Wiebe et. al., in press), except that it is longer by 4-6 inches to accommodate all of the new transducers. Care was taken to avoid making any significant changes in the size, shape, weight, and weight distribution in order to maintain a high degree of confidence in its already proven towing characteristics. We elected to go with a "dead weight body" because of its simplicity and functionality and to ensure low manufacturing and operational costs.

The vehicle is a free-flooded open-frame architecture with an outer skin in the form of easily removable flat plastic panels (Figure 2). It weighs 2000 lbs in air and 1200 lbs in water, has a length of 3.78 m, a height of 0.85 m for the main framework, a height of 1.19 m to the top of the VPR framework, and an overall height of 2.0 m to the top of the towing bail. The body is 0.55 m wide at the nose (not including the side rails which add 0.22 m overall) and is 0.27 m wide at 0.6 m in front of the tail. The frame is welded aluminum angles in an open box-type shape that allows for simple installation of instruments and wiring. To improve the pitch stability, we found that a lot of weight down low was important on BIOMAPER. On BIOMAPER II, the weight is located to meet this need. Shock mounts are installed on the bottom and front of the towbody for protection during launch and recovery, as well as for vibration isolation during shipments by truck. In addition, 0.75" SS round stock was used to form side rails that act as side fenders and provide access points for handling lines.

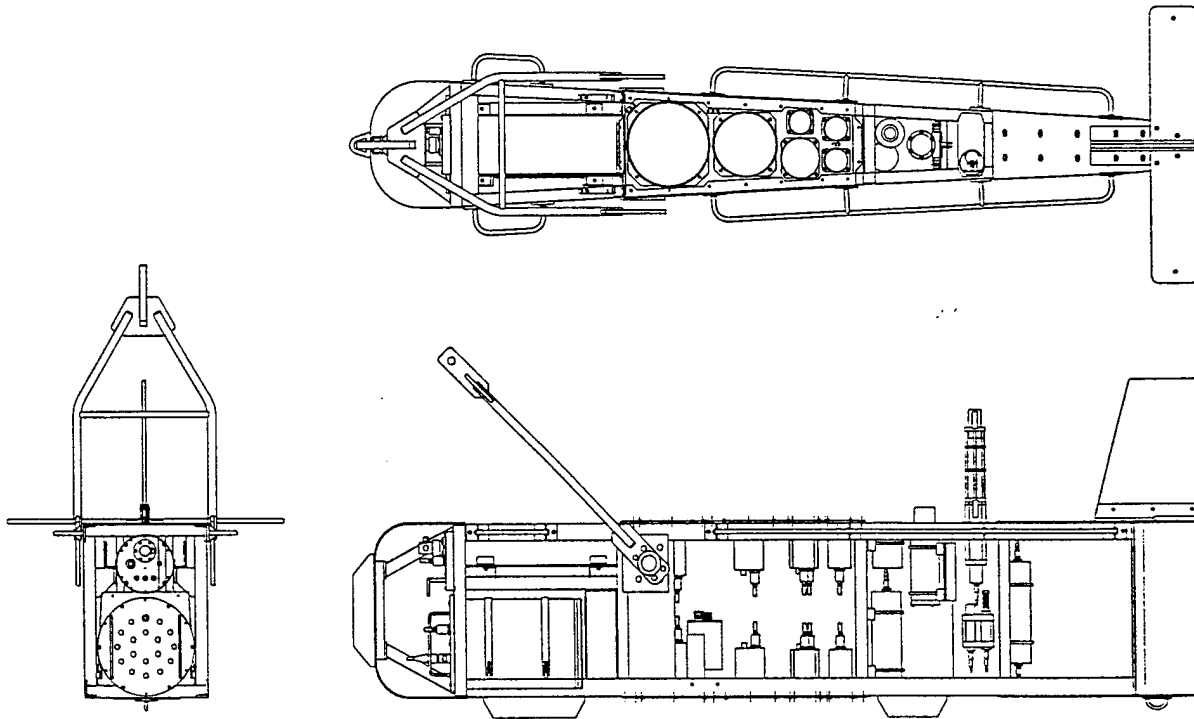

Figure 2. Design drawing of BIOMAPER II which provides a top view, side view, and front view of the framework with the instrument housings installed. (Drawing by Richard Arthur).

The frame has 4 "bays" which are:

Nose bay#1: The nose bay, at the very front of the vehicle, is a fiber glass shell with aluminum reinforcing struts that is easily bolted to its attachment points on the main body of the fish. Unbolting it and moving it forward provides access to the nose itself, and to the forward end of Bay #2 where all the ABSS and telemetry connectors are located.

Bay #2: This bay, between the nose and the tow point, is where the large electronics bottles, and the oil filled junction-box(s) are located.

Telemetry/Power Bottle: This bottle contains all the DC/DC converters for generating the various system power supplies from the DC tether voltage. The DC tether voltage is 300 volts DC, with no load, and will drop to 200 volts DC with a maximum load of 2 KW in the vehicle (based on 1 km of 0.68" Rochester cable). At this time, the load is less than 500 watts, thus there is a good reserve of power available for the future. The power supplies are Vicors, with the OSL Vicor interface boards providing input and output filtering, on/off control, transient protection, and wiring interface connectors. Vicor provides a wide selection of output voltages that meet the system specifications over an input range of 200-400 volts DC, so that no tether voltage regulation is required. Also, since the tether voltage

will never go above 300 volts, the vehicle cannot be over-voltaged.

Also in this bottle are the video and data telemetry interfaces to the fiber-optic tow cable. Two channels of video are supported using the Force, Inc. model 2768T fiber-optic video modulators, although only one camera was purchased initially. These are compact units, which need only +12 volt power, and are available in both 1300 and 1550 nm versions. One of each is installed in this bottle, and mix the outputs onto a single fiber with a fiber optic wave division multiplexer (WDM).

Data telemetry is ethernet only via a TC Communications model TC3100 ethernet single mode fiber optic transceiver. This converts AUI ethernet onto two optical fibers, at 1300 nm wavelength for uplink and 1550 nm wavelength for downlink. This allows both directions of ethernet to be mixed onto a single fiber with wave division multiplexers. It is good to at least a cable length of 2 km and perhaps more. A twisted pair MAU (media adapter unit) with 4 or 8 ports is attached to the AUI on the fiber optic transceiver. This allows multiple ethernet devices in the vehicle to share the network. At this time there are only two ethernet devices. One is the ABSS, and the other is a PC-104 computer stack in the telemetry/power bottle. This computer board stack provides control I/O for various vehicle functions such as power switches, voltage and current monitors, ground fault detection, and water leak detectors. In addition it serves as a pass through for the serial interface for the ESS system. A sail to RS-232 converter is included for the ESS interface.

ABSS Electronics Bottle: The ABSS electronics bottle is a large titanium pressure case of about 16" OD by 20" long. It contains the acoustic transducer transmit and receive electronics for up to 6 frequency channels, and provides bulkhead connectors on its front end cap for two transducers per channel. There is also a power/data connector for control in, data out, power in, external trigger in, and sea water switch leads. An oil filled cable and connector mates to the power/data connector, and routes to the oil filled junction-box through a hose barb (this is an XSL type connector for oil filled applications). All the transducer cables go directly to their respective transducers. This connector end-cap is immediately accessible by simply opening the fish nose cone.

WHOI designed the ABSS Electronics pressure housing and end cap, and a contractor built it. In addition, WHOI procured and installed all of the bulkhead connectors in the end cap. The connectors were specified by HTI (there are sixteen SEACON XSK type for the transducers (four spares), and one SEACON XSL type for the power/data). All connectors were installed in the end cap with pin 1 (or the key way in the case of the XSL) up. Prior to installation, these connectors were shipped to HTI for pre-wiring to avoid difficulties wiring them after installation. WHOI procured pressure proof caps for all connectors, and WHOI pressure tested the housing prior to shipment to HTI. A dry nitrogen purge plug was installed in the end cap up high. The housing material is titanium, and the unit is isolated from the aluminum frame since it does not need anodic protection. Two probes are mounted on the

front top of Bay#2 as penetrators, to sense submergence in sea water. This is a safety interlock to prevent the ABSS from transmitting in air.

Oil Filled Junction Box: There is a single shallow oil filled box located on the side of this bay, with an aluminum cover. Power comes in through the tether as DC, and routes directly to the telemetry/power bottle for distribution. This junction box consists of terminal strips for the tether and for all of the frame wiring between the telemetry/power bottle and the sensor systems. It also contains three ST fiber optic couplers mounted on a bulkhead inside the box to allow for easy attachment and removal of the tether. From the junction-box, there are three discrete DGO "steelite" pigtail connectors which mate to three DGO single mode fiber optic bulkhead connectors on the telemetry/power bottle front end-cap. The terminal strips are mounted on standoffs in case a little water gets into the box. A compensation bladder with a spring to maintain positive pressure is mounted below the box in Bay#3 on a quick disconnect oil fitting. The bladder serves two purposes: one is to provide pressure compensation to the oil filled system, and the other is to act as a sump for water to fall into in the event that there is a leak in the box cover or stuffing glands. An oil filled hose routes from the box to a multi-pin connector to plug into the telemetry/power bottle. This hose exits the side of the box, so that it does not attract water.

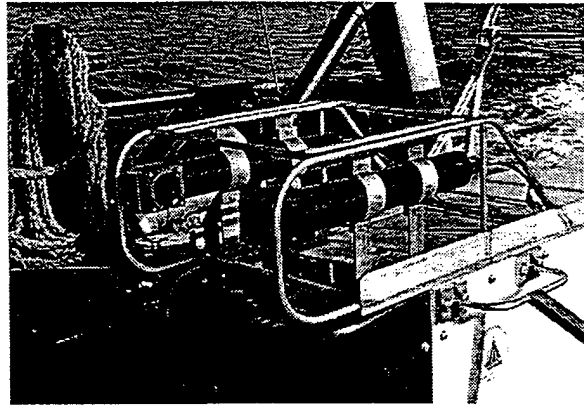

Figure 3. The VPR camera (black tube left) and strobe light (black tube right) mounted on top of BIOMAPER II.

VPR Hardware: The camera and strobe are mounted above the top surface of Bay #2 in front of the towing bail, so that the video images are taken in undisturbed water (3 2). The camera and strobe housings are attached to a framework, made from solid stainless steel rod that protects these parts during launch and recovery. This guard does not, however, disturb the water in the field of view of the VPR cameras. VPR video-signals route through the oil filled junction-box to the telemetry/power bottle. Power and control command interfaces come from the ESS system in Bay #4.

Bay #3: This bay, in the center of the fish between the tow point and the tail, is where all of the ABSS transducers are located. There are 10 transducers, 5 looking up and 5 looking down. The frequencies used are 43 kHz, 120 kHz, 200 kHz, 420 kHz, and 1 MHz. The transducers are arranged with the 43 kHz at the forward end of the bay, followed by the 120 kHz, then the remaining three at the aft end of the bay. Space is reserved for a future transducer of the same

dimensions as the 1 MHz unit. All cables are routed forward to the ABSS electronics bottle connector end cap. These transducers are installed in anodized cases with zinc anode protection. They are electrically isolated from the frame by mounting them on plastic mounts.

Bay #4: This is the aft most bay, and includes the tapered section at the tail. This bay serves as the location for all of the ESS sensors and electronics bottles. The ESS system connects to the telemetry bottle for power and sail connections. The sail interface is converted to RS-232 and fed into the telemetry PC-104 computer for transmission to the surface over the ethernet. Since the VPR is essentially an ESS module, cables route from this bay to the hardware mounted above Bay #2 for the VPR power and data control link.

The Sensor Systems.

The Acoustic Backscattering Sonar System (ABSS): As described above, the high-frequency acoustics system in BIOMAPER II is housed in a titanium pressure vessel containing most of the electronics and a combination of distributed and centralized processing units. The underwater housing contains all of the signal processing hardware associated with the Acoustic Backscattering Sonar System (ABSS). A large end cap contains an array of 12 transducer connectors. Inside, these connections are routed to a multiplexor board which selects which of the twelve transducers is to be currently active. The multiplexor connects the active transducer to one of six dedicated frequency receiver channels. Four of the receiver channels are dedicated to multi-beam transducers, and the last two channels are for high-frequency (1 and 2 MHz), single-beam transducers. Each receiver board includes a multi-channel TVG, band pass filtering, quadrature demodulation, and Analog-to-Digital (A/D) conversion. Once the signal has been digitized, all further filtering and echo processing is performed by distributed DSPs for such functions as matched filtering, echo-integration, target detection, and target tracking. There are two transmitter boards required, one to cover the low-frequency range of 43 to 200 kHz and a second to cover the high-frequency range of 420 kHz to 2 MHz. The transmit signal is routed through the multiplexor board to the selected transducer connector. A local PC-104 micro-computer is included to format the acquired data for transmission to the surface, and also to receive commands and new firmware downloads from the surface console, via a 10 Base-T ethernet connection.

Both the transmitter and receiver processing are under DSP control. This allows much flexibility in signal design. The standard firmware and control software includes operator selection of frequency, pulse length, and chirp options, allowing the user to take full advantage of the available transducer bandwidth to improve the signal-to-noise ratio at the receiver output.

The surface control console is a Pentium-based PC running the HTI system control and processing software. This console is connected onto the ethernet communications link to the subsea tow body, allowing it to send commands and receive data from the ABSS. A convenient WINDOWS95-based operator interface allows full control of multiplexor sequencing and ping

rates, as well as providing multi-window color displays for echo-integration data, target tracking, and target-strength statistics. Data may be logged locally to the PC hard drive or remotely to another network drive for global access.

The Environmental Sensing System (ESS): The ESS consists of SeaBird temperature and conductivity sensors, a SeaBird pump, a WetLab fluorometer, a SeaTech transmissometer, and a downwelling irradiance sensor. The conductivity, temperature, fluorometer, and pump are connected in series with tygon tubing and the pump draws water past these sensors. Data are gathered on a Serial Ascii Interface Loop (SAIL) at selectable speeds ranging from 0.25 to 4 Hz. The surface control console is a PC running a Visual Basic system control and processing software program.

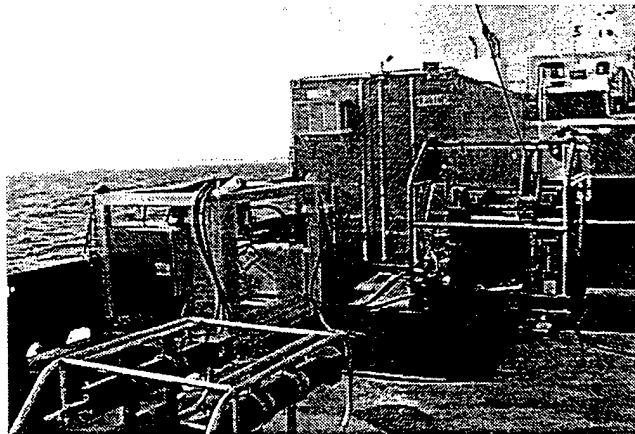

Figure 4. The winch (framework to the right) and the power pack assembly (framework left) on the deck of the Diane G.

The Video Plankton Recorder (VPR):

The VPR is a high resolution camera video imaging system designed to unobtrusively quantify the distribution and abundance of zooplankton and bubbles encountered along the tow path at 60 fields per second (3). The VPR has a concentric viewing volume of about 1000 mm³. Illumination is provided by a columnated 80 W xenon strobe which incorporates a parabolic reflector and red filter (>600 nm) which minimizes detection by target organisms. Dark-field illumination is provided by the oblique angle between the camera and strobe. The high resolution of the camera (570 horizontal x 485 vertical TV lines) and short ($\approx 1 \mu\text{s}$) pulse duration of the strobe permits detailed imagery of target organisms moving in relation to the camera. Currently, the video data are transmitted to a VCR and recorded on SVHS tape for post-processing.

The Winch.

The BIOMAPER winch (which was not purchased on this grant) includes an outside control console, with the capability of adding a remote control interface in the control van in the future (Figure 4). One of the deck cameras can be mounted near the winch. Another can focus on the launch and recovery location and the towing tether angle. The electro-optic tether core terminates in a rotating junction-box in the drum core. This junction-box contains the following modules: TC3100 AUI to fiber optic transceiver, AUI to twisted pair MAU, two WDMs, and two Force 2768R-O-BFST fiber optic video receivers. These are all small, flat modules, which pack nicely into the rotating junction-box and remove the need to have a fiber-optic slip ring (Figure 5). A deck cable consisting of 2 coax's and a 12 volt power supply pair is routed from the slip ring junction-box to the control van.

These coax's are: ethernet and one video channels. The slip ring (Focal Technologies) has:

Power: 3 rings @ 480 V, 20 amps
Coax: 2 small signal coaxial rings
twisted pair: 4 twisted pair

This arrangement provides for one spare power, one spare coax, and two spare twisted pair.

The tether does not currently have instruments to measure tension, speed, and line out, but they are needed. This sensor suite should have its own display console, ideally with a serial output for computer logging. One candidate is the MD-TOTCO SI102-36 instrumented sheave, with its own display/RS-232 box. This gives tension, speed, and line out. This is an attractive approach, because it would enable BIOMAPER II to be equipped with its own overboard sheave, thus eliminating that uncertainty when operating off a ship of opportunity.

The Tow Cable.

A steel armored tether, the standard 0.68" OD Rochester cable, of 700 meters length is installed on a re-built hydraulically driven winch. The tow cable contains three single mode optical fibers and three copper power conductors and is known for its superior strength and very good performance and power transmission capability. Data telemetry occupies one fiber (using two colors) and video the second. The third fiber is a spare for now. A cable termination matched to meet the strengths of the towing cable and the towbody's towing bail was designed and built at WHOI. It is a poured fitting using Cerrobend, a low melting point synthetic metal. Test were done to make sure the termination could withstand loads in excess of 8000 lbs

The cable core is stripped out from the armor at the termination. About 10 feet of core is required to go from the termination, along the tow-bridle, into the fish and up to the small tether termination junction-box. An additional 18 inches of stripped conductors and fibers is required for terminations inside the box. The conductors go to a terminal strip, and the fibers go to bulkhead mounted ST couplers. Therefore, the total length of the stripped armor core is about 12 feet. To separate the tether from the fish, one needs only to unmate four connectors from the end cap of the telemetry/power bottle and remove the tether along with its junction-box and pigtail connectors from the fish.

The Control Van.

The BIOMAPER control van is a 8 x 20 foot ISO container finished off on the inside as a lab (Figure

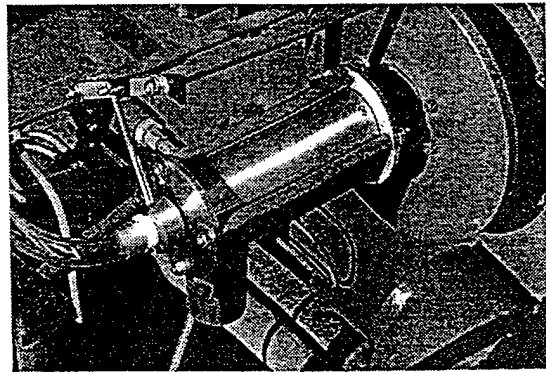

Figure 5. The slip ring assembly mounted on the winch.

6). A Formica topped bench extends the entire length and width of the van along two adjacent walls, forming an "L". Above the 20 foot section in the center is a set of 19 inch rack mounting rails, hung from the ceiling on shock isolators. The rack has 3 adjacent bays, 21 inches inside height. In the countertops are tie down sockets for monitor pedestals and other gear. Under counter platforms are provided for 4 mini tower PC chassis. Outlet strips are provided both below the bench and above the bench along the wall. Several 4" diameter holes are drilled in the counter top along the back edge for bringing monitor, keyboard, mouse, network and RS-232 cables up to the bench top.

The 19" rack holds the BIOMAPER DC power supply, which is an Electronic Measurements, Inc. EMS300-8-2-D. It has a 3.5" panel height, 20 inch depth, weighing approximately 40 lbs. Also, the 19" rack holds 2 color monitors which can be switched for viewing the deck or the VPR video and a VCR. The rack also holds an output strip for a 12-channel Rockwell Zodiac GPS receiver and a time code generator for the VCR.

A Sanyo air conditioner / heat pump is mounted at the far end in a recessed box. The compressor is mounted on sliding brackets which are retracted for shipping. Inside the van, the unit has an infrared remote for thermostat, heat, and cool controls. A back-up electrical heater is also included in the unit for weather too cold for the heat pump.

Under the bench at both ends is a set of tool and storage drawers. A white board and a cork board are installed on the wall opposite the bench, along with one high shelf.

Power for the Van is 440-480 VAC, single phase. The power line enters through a connector in the rear of the van and runs to a 10 KVA step down transformer which provides 220 v single phase with a neutral to the circuit breaker panel. The electrical breaker panel is located on the end wall next to the air conditioner.

Other Features.

Troubleshooting: All systems on the fish power up when the BIOMAPER power supply is energized at the surface. A PC with a Visual Basic program displays the BIOMAPER status and includes things such as ground fault and water leak status, and pitch and roll angle. Water leaks are sensed in the telemetry/power bottle and the junction box. Troubleshooting is accomplished by powering off, unplugging systems, installing dummy

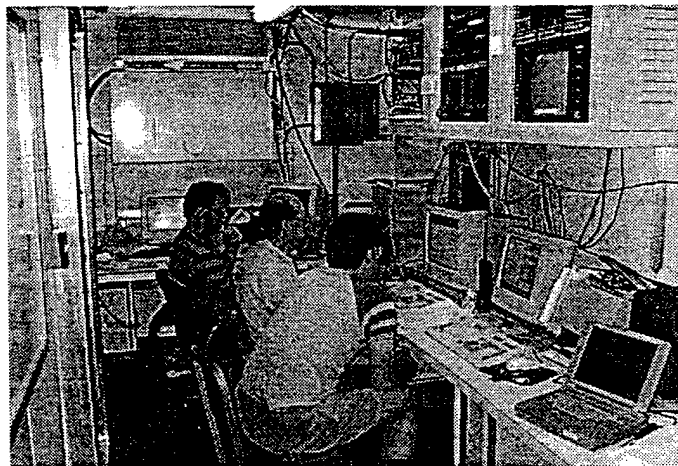

Figure 6. The inside of the 20' BIOMAPER II data acquisition and control van.

connectors, and re-dipping in sea water. All systems are isolated to assist in ground fault trouble shooting. Therefore, it is possible to distinguish whether the fault is in the tether or on the fish (ABSS, ESS, VPR, etc). If the fault is in the fish, it will most likely be one of many connectors. To determine which system is at fault, the user simply powers down each individual system (remotely) until the fault goes away. Once the system is found, the individual connectors in that system need to be inspected and cleaned as a first step in fixing the problem.

Future Sensors: Provisions are made in the wiring of the oil filled box and the telemetry/power bottle to accommodate a future high sample rate probe. A 200 kHz maximum sample rate A/D board is included in the PC-104 stack for miscellaneous I/O. Spare analog channels are wired in for these future probes. A future program could be written to sample these ports and send the data up the ethernet to a surface computer for logging.

REPORT DOCUMENTATION PAGE

Form Approved
OMB No. 0704-0188

Public reporting burden for this collection of information is estimated to average 1 hour per response, including the time for reviewing instructions, searching existing data sources, gathering and maintaining the data needed, and completing and reviewing the collection of information. Send comments regarding this burden estimate or any other aspect of this collection of information, including suggestions for reducing this burden, to Washington Headquarters Services, Directorate for Information Operations and Reports, 1215 Jefferson Davis Highway, Suite 1204, Arlington, VA 22202-4302, and to the Office of Management and Budget, Paperwork Reduction Project (0704-0188), Washington, DC 20503.

1. AGENCY USE ONLY (Leave blank)		2. REPORT DATE 8/97	3. REPORT TYPE AND DATES COVERED FINAL REPORT 7/1/95 - 12/31/96	
4. TITLE AND SUBTITLE A HIGH PERFORMANCE TOWED PLATFORM FOR BIO-OPTICAL, ACOUSTICAL, AND PHYSICAL DATA ACQUISITION			5. FUNDING NUMBERS N00014-95-1-1102	
6. AUTHOR(S) P.H. Wiebe, T.K. Stanton & C.H. Greene				
7. PERFORMING ORGANIZATION NAME(S) AND ADDRESS(ES) WOODS HOLE OCEANOGRAPHIC INSTITUTION WOODS HOLE, MA 02543			8. PERFORMING ORGANIZATION REPORT NUMBER WHOI #9465.1	
9. SPONSORING/MONITORING AGENCY NAME(S) AND ADDRESS(ES) OFFICE OF NAVAL RESEARCH (DURIP) 800 NORTH QUINCY STREET ARLINGTON, VA 22217-5660			10. SPONSORING/MONITORING AGENCY REPORT NUMBER N00014-95-1-1102	
11. SUPPLEMENTARY NOTES				
12a. DISTRIBUTION/AVAILABILITY STATEMENT Approved for public release; distribution is unlimited.			12b. DISTRIBUTION CODE	
13. ABSTRACT (Maximum 200 words) We have purchased the component instruments and assembled them in a custom towed body for acquisition of high frequency acoustics data, high frame rate video data, and environmental data. The system, BIOMAPER II, operates using a fiber optic telemetry unit and a cable with 3-glass fibers at ship speeds up to 10 kts. The cable, winch, and slip rings together with a shipping van are included as part of the system so that it can be shipped around the world and operated from most research vessels with little outfitting required. The system will principally be used to acoustically and optically map the spatial and temporal distributions of biological sound scatterers. A companion objective is to measure acoustic scattering from near-surface bubbles using the upward looking transducers, scattering from turbulence, and physical and bio-optical properties of the water. This surveying system addresses a major sampling constraint associated with conventional net sampling systems that of under sampling the complex spatial distribution of the organisms. Use of this quantitative survey system will enable sampling of the structure and filling in of the data between stations. Acoustics data can be integrated with video information to "ground truth" the acoustics data. BIOMAPER II estimates of target strength of the animals can be compared with a set of scattering models that predict high frequency acoustic reverberation. Our successful first field test of the system took place in local Gulf of Maine waters with support from our existing ONR grant.				
14. SUBJECT TERMS			15. NUMBER OF PAGES	
			16. PRICE CODE	
17. SECURITY CLASSIFICATION OF REPORT	18. SECURITY CLASSIFICATION OF THIS PAGE	19. SECURITY CLASSIFICATION OF ABSTRACT	20. LIMITATION OF ABSTRACT	