

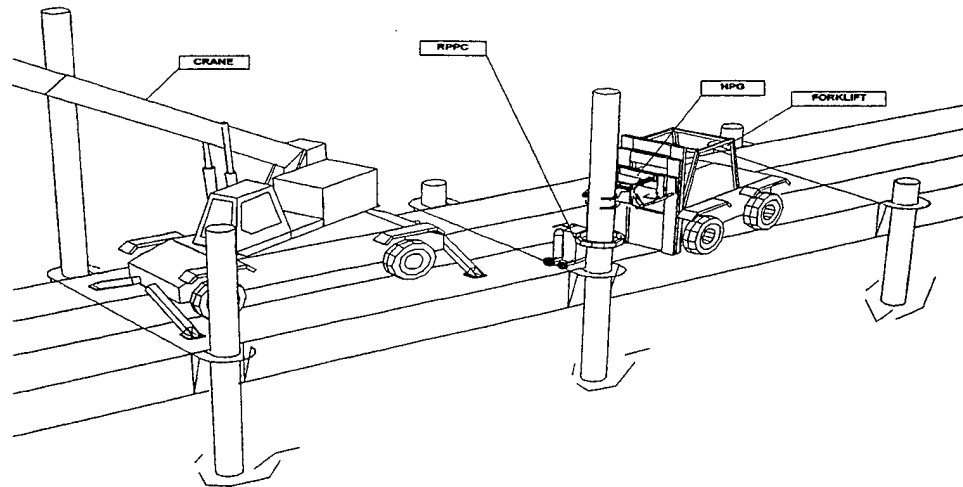

NAVAL FACILITIES ENGINEERING SERVICE CENTER
Port Hueneme, California 93043-4370

CONTRACT REPORT CR-97.005

PORTABLE RAPID PIPE PILE CUTTER SYSTEM - Phase I



19970825 131

An Investigation Conducted by

Cardinal Scientific Inc.

May 1997

DEQ QUALITY INSPECTED 8

Approved for public release; distribution is unlimited.



Printed on Recycled Paper

REPORT DOCUMENTATION PAGE			Form Approved OMB No. 0704-018	
Public reporting burden for this collection of information is estimated to average 1 hour per response, including the time for reviewing instructions, searching existing data sources, gathering and maintaining the data needed, and completing and reviewing the collection of information. Send comments regarding this burden estimate or any other aspect of this collection information, including suggestions for reducing this burden, to Washington Headquarters Services, Directorate for Information and Reports, 1215 Jefferson Davis Highway, Suite 1204, Arlington, VA 22202-4302, and to the Office of Management and Budget, Paperwork Reduction Project (0704-0188), Washington, DC 20503.				
1. AGENCY USE ONLY (Leave blank)		2. REPORT DATE May 1997		3. REPORT TYPE AND DATES COVERED Interim; Nov 1995 - Jul 1996
4. TITLE AND SUBTITLE Portable Rapid Pipe Pile Cutter System			5. FUNDING NUMBERS	
6. AUTHOR(S) Co-authors: Cardinal Scientific, Inc.				
7. PERFORMING ORGANIZATION NAME(S) AND ADDRESS(S) Cardinal Scientific, Inc. 7594 Commerce Lane Clinton, MD 20735			8. PERFORMING ORGANIZATION REPORT NUMBER CR -97.005	
9. SPONSORING/MONITORING AGENCY NAME(S) AND ADDRESSES Naval Facilities Engineering Service Center 1100 23rd Avenue Port Hueneme, CA 93043-4370			10. SPONSORING/MONITORING AGENCY REPORT NUMBER	
11. SUPPLEMENTARY NOTES				
12a. DISTRIBUTION/AVAILABILITY STATEMENT Approved for public release; distribution is unlimited.			12b. DISTRIBUTION CODE	
13. ABSTRACT (Maximum 200 words) The Modular Elevated Causeway System, ELCAS(M) is used during Amphibious Operations to transfer vehicles, materials and containerized cargo from deep draft ships moored offshore. The cargo is transported on the ELCAS(M) to an unimproved beach staging area for dissemination to the field. Rapid erection is essential to the ELCAS(M) mission. Cardinal Scientific, Inc. (CSI) was awarded a contract to develop a rapid pile cutting technology and pile handling system to minimize crane time during ELCAS(M) assembly. CSI investigated, designed, analyzed and constructed models capable of demonstrating the salient characteristics of a full scale rapid pile cutting system and pile handler and were used to generate empirical data. Investigations of several technologies were performed. The Automated Plasma Arc (APA) Rapid Pipe Pile Cutter is designed in a "clamshell" fashion to allow easy placement around and removal from the pile. The Hydraulic Pile Gripper (HPG) is a self-contained, portable pile handling aid. The results of the effort indicate that the model designs are operationally feasible and practical for use by the U.S. Navy. These results established an excellent foundation for transition into Phase II, in which the models will be reviewed and shortcomings addressed, and improvements incorporated into a prototype system.				
14. SUBJECT TERMS Pile cutting, plasma arc, modular elevated causeway, pile gripper			15. NUMBER OF PAGES 110	
			16. PRICE CODE	
17. SECURITY CLASSIFICATION OF REPORT Unclassified	18. SECURITY CLASSIFICATION OF THIS PAGE Unclassified	19. SECURITY CLASSIFICATION OF ABSTRACT Unclassified	20. LIMITATION OF ABSTRACT UL	

Table of Contents

1.0 Background	1
2.0 Introduction	1
3.0 Assessment and Trade-Offs of Cutting Methods	1
3.1 Shear Cutting	3
3.2 Thermal Cutting	4
3.3 Chemical Cutting	5
4.0 ELCAS(M) Pile Cutting Application	6
5.0 Technical Approach	7
5.1 Multi-head Oxy-acetylene Torch Array (MOTA) Rapid Pipe Pile Cutter (RPPC)	7
5.2 Automated Plasma Arc (APA) Rapid Pipe Pile Cutter (RPPC)	9
5.3 Hydraulic Pile Handler (HPG)	11
6.0 Concept Development and Analysis	15
6.1 User Input	15
6.2 Design Parameters	16
6.3 Full-Scale System Requirements	16
6.3.1 RPPC Requirements	16
6.3.1 HPG Requirements	17
6.4 Demonstration Model Design and Analysis	20
6.4.1 Model RPPC Design	20
6.4.2 Model RPPC Analysis	24
6.4.3 Model RPPC Safety Assessment	27
6.4.4 Model HPG Design	27
6.4.5 Model HPG Analysis	29
6.4.6 Model HPG Safety Assessment	33
7.0 Model Testing and Evaluation	34
7.1 Test Plans	34
7.1.1 RPPC Test Plan	34
7.1.2 HPG Test Plan	36
7.2 Test Results	37
7.2.1 RPPC Test Results	37
7.2.1.A. Maneuverability, Stability, and Self-Centering	37
7.2.1.B. Control System Operation	37
7.2.1.C. Establish Piercing Dwell Times, Output Amperages, and Drive Unit Speed Settings	37
7.2.1.D. Automatic Cutting	40
7.2.2 HPG Test Results	43
7.2.2.A. Control System Operation	43
7.2.2.B. Gripping Force, Tilt Speed	43
7.2.2.C. Maneuverability, Stability, and Self-Centering	43

Table of Contents (cont.)

7.2.2.D. Combined Testing	45
8.0 Conclusions	45
9.0 Recommendations	49
References	50

Appendices

Appendix A - Model RPPC Detailed Design Drawings
Appendix B - Model RPPC Calculations
Appendix C - Model HPG Detailed Design Drawings
Appendix D - Model HPG Calculations
Appendix E - Model RPPC and HPG Instructions

Executive Summary

The Modular Elevated Causeway System, ELCAS(M) is used during Amphibious Operations to transfer vehicles, materials and containerized cargo from deep draft ships moored offshore. The cargo is transported on the ELCAS(M) to an unimproved beach staging area for dissemination to the field. Rapid erection is essential to the ELCAS(M) mission.

During assembly, 24 in. diameter steel piles are driven into the sea floor to which the causeway sections are attached. The piles extending above the causeway surface must be cut off to permit delivery of the next section for installation. Pile cutting is performed using manual cutting torches while the pile is supported by a crane. Approximately 60 hours of crane time are required to cut more than 160 piles for a 3000 foot long causeway.

Cardinal Scientific, Inc. (CSI) was awarded contract number N47408-95-C-0240, Rapid Pipe Pile Cutter on 03 November 1995 by the Naval Facilities Engineering Service Center (NFESC), Port Hueneme, CA under the Phase I, Small Business Innovation Research (SBIR) program to develop a rapid pile cutting technology and pile handling system to minimize crane time during ELCAS(M) assembly.

CSI investigated, designed, analyzed and constructed models capable of demonstrating the salient characteristics of a full scale rapid pile cutting system and pile handler and were used to generate empirical data. Investigations of several technologies were performed.

The Automated Plasma Arc (APA) Rapid Pipe Pile Cutter is designed in a "clamshell" fashion to allow easy placement around and removal from the pile. The Hydraulic Pile Gripper (HPG) is a self-contained, portable pile handling aid. The results of the effort indicate that the model designs are operationally feasible and practical for use by the U.S. Navy.

The results of the Phase I effort have established an excellent foundation for transition into Phase II. Under Phase II the models will be reviewed and shortcomings will be addressed and improvements will be incorporated into a prototype system.

Portable Rapid Pipe Pile Cutter System

1.0 Background

The Modular Elevated Causeway System, ELCAS(M) is used during Amphibious Operations to transfer vehicles, materials and containerized cargo from deep draft ships moored offshore (see Figure 1). The cargo is transported on the ELCAS(M) to an unimproved beach staging area for dissemination to the field. Rapid erection of the ELCAS(M) is essential to delivering vital supplies and armaments for the fighting effort.

During the assembly of the elevated causeway, steel piles are driven into the sea floor to which the causeway sections are attached. Once each section of causeway is assembled the piles extending above the causeway surface must be cut off to permit delivery of the next section for installation. The steel piles currently in use are 24 inches in diameter with a wall thickness of 0.5 inch. Pile cutting is performed using manual cutting torches while the pile is supported by a crane. Taking between 15 to 20 minutes to accomplish, average process speeds range from only 3.7 to 5.0 inches per minute (ipm) given the 75.4 in. circumferential distance. This occupies a significant portion of the cranes time. Approximately 60 hours of valuable crane assistance are required to cut and remove more than 160 piles for a 3000 foot long causeway. The ELCAS(M) can be made operational significantly faster by implementing a superior technology for steel pile cut off.

2.0 Introduction

Cardinal Scientific, Inc. (CSI) was awarded contract number N47408-95-C-0240, Rapid Pipe Pile Cutter on 03 November 1995 by the Naval Facilities Engineering Service Center (NFESC), Port Huneme, CA under the Phase I, Small Business Innovation Research (SBIR) program to develop a pile cutting technology and pile handling system to minimize the use of the crane during ELCAS(M) cutting operations.

CSI proposed to investigate, design, analyze and construct a model system capable of demonstrating the salient characteristics of a full scale rapid pile cutting system and pile handler. The demonstration model will be used to verify the operational concepts developed and provide empirical data for the development of a full scale system under Phase II. The compilation of the Phase I effort is presented in this report.

3.0 Assessment and Trade-Offs of Cutting Methods

A traditional solution does not exist for rapidly cutting and handling the steel pile foundations which meets the time constraints of the ELCAS(M) deployment. There are many issues which make this a truly unique application for any metal cutting technology. Environmental extremes, congested work area, and limited infrastructure are just a few of the many issues which must be addressed with the development of a cutting technology and pile handling equipment.

ASSEMBLY

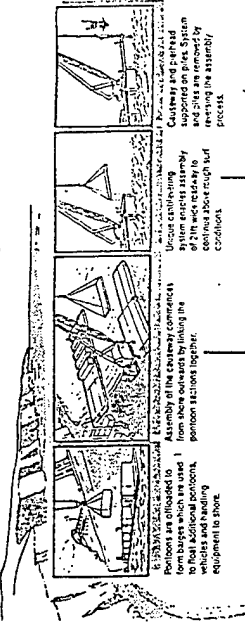

MISSION

A modular causeway system which allows deep draught supply ships to unload cargo onto any beach. It can be transported by a single supply vessel to provide a self-sufficient cargo unloading facility up to 3000ft long. Assembly is seven days or less.

CHARACTERISTICS

- Turn-key self contained system
- Transportable on any ISO containership
- Unique cantilevering weather resistance
- Rugged and efficient off-loading
- 100% mission readiness
- Personnel and ship safety designed-in
- Unequaled logistics over the shore
- Uncompromised traffic management
- Versatile lighterage compatibility

CONSTRUCTION

The system is fabricated out of plate steel using custom designed state of the art automated welding processes. The system is capable of functioning as a stand alone fully operational pier facility.

MAJOR EQUIPMENT

DESCRIPTION	QTY. PER FACILITY
Pierhead Cranes (165 Ton)	2
Pierhead Turntables	2
Rough Terrain Cargo Handling Vehicle	2
Mobile Hydraulic Crane (RT) 30 Ton	1
Forklift (RT with extender Boom) (CAT950)	1
Forklift with Extendable Boom (Trak International 6000)	1
Air Compressors	4
Generators	2
Beach Matting	Lot
Welding Machines	4
Pile Drivers	2
Pile Extractors	1
Portable Light Plants	4
Fender Cushions	24
Fog Horn	1
Navigational Lights	Lot

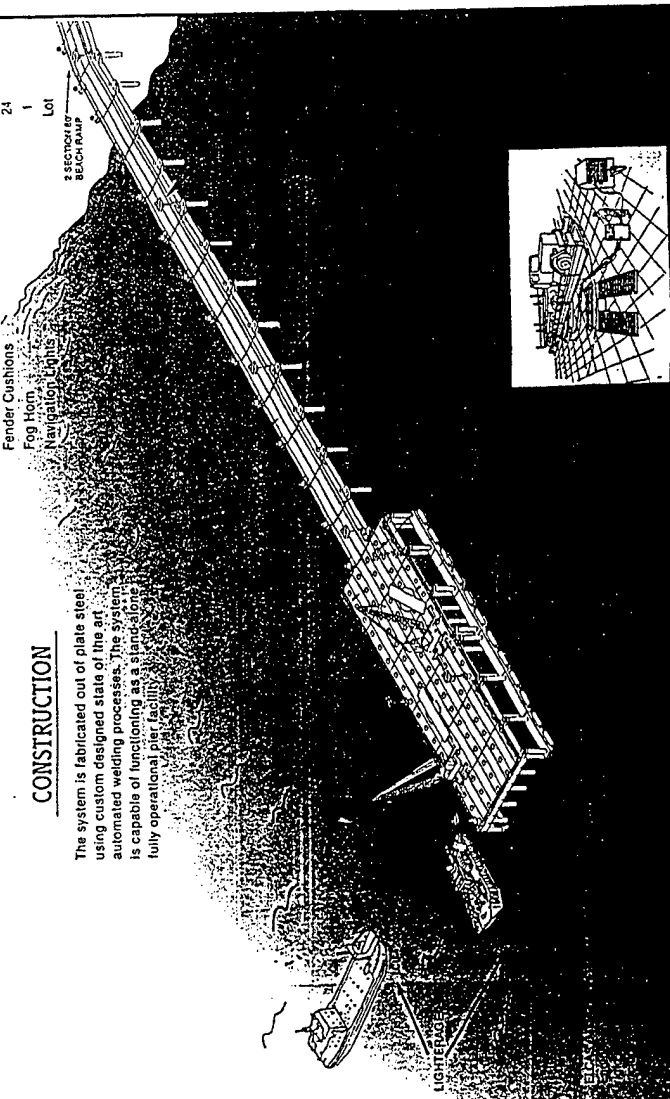

Figure 1 - Elevated Causeway System (Modular), ELCAS(M)

Investigations of several candidate technologies was performed. Each has distinctive characteristics and were weighed against the parameters of the ELCAS(M) deployment scenario.

A number of methods exist for cutting steel. Perhaps, the most common for rapid material removal is the oxy-acetylene cutting torch (manual and automated) followed by various mechanical shearing, sawing methods (cold saw, abrasive wheel, etc.), plasma arc, and carbon arc. More sophisticated technologies include explosive shearing, chemical, ultrasonic, radio frequency (RF), water jet and laser. All methods of metal cutting can be classified in one of three categories: 1) shear, 2) thermal, 3) chemical. Each method has significant advantages and disadvantages for particular applications.

3.1 Shear Cutting

Forms of cutting such as bandsaws, cold saws, mill cutters and other toothed cutter operations perform a mechanical shearing process at the micro level. The toothed cutters are made of heat treated, higher strength materials than those of the material to be cut. As each tooth of the cutter engages the material, a small chip or sliver is sheared from the parent material with each revolution or pass of the cutter.

The speed of toothed shearing tools is limited to the size of the chip able to be sheared as the energy is transformed into heat. Effective dissipation of the heat energy is essential to maintaining the shearing edge of the toothed cutter. Excessive heat retained in the cutter will cause temperature increases beyond the working temperature and/or melting temperature of the cutter material in the shear edge of the teeth. Each engagement of the tooth at elevated temperatures reforms the shape of the shear edge and/or welds chips to the shear edge reducing its ability to shear on all subsequent passes. Effective cooling extends tool life but material removal is relatively slow.

Water jet cutting shears metal on the micro level as waterborne abrasives are delivered under extreme pressures (up to 55,000 psi) to the workpiece. The extremely small (0.004 to .020 in.) nozzle raises the slurry to supersonic velocities. These systems have been applied in many industries. Cutting speeds range up to 20 ipm for 1/2 inch steel. The complex system of collection tanks, skimmers, filtration units, pumps, etc. limits the mobility of these systems. Like laser systems, appropriate absorption or deflection backing is necessary to diffuse the high speed jet.

On macro level, tools ranging from common tin snips to large shear press machines are used to shear an entire thickness of material in a single pass. These types of equipment are used for processing flat plate, solid bar stock, and circular hollow cross section materials. Since the effective area in shear is substantially greater than that of toothed cutter, large forces are necessary. However, the speed of shearing material on a macro level is significantly faster since shearing of the entire thickness typically occurs during a single pass of the shear knives.

Rotary shearing is another common form of cutting circular cross section material. A typical example of a rotary shear is a pipe cutter a plumber or fabricator may use. Rotary shearing

is accomplished by forcing a circular shear knife into the material and rotating it about the pipe. With each revolution the shear knife is forced deeper into the material, shearing a portion of the cross section. The depth of each pass is determined by the allowable deformation of the cut end and toughness of the shear knife. Automated rotary shears can rapidly perform cutoffs in few revolutions.

Explosive shape charges perform shearing operations in similar fashion as single pass mechanical shear presses. Instead of a mechanical device delivering the required shear force to the material, the energy is delivered in the form of a directed blast overpressure. The shock wave generated by the blast occurs in milliseconds; instantaneously shearing the section. However, trained personnel and a number of dedicated safety measures accompany this technology.

3.2 Thermal Cutting

Laser, plasma arc, ultrasonic, RF, and oxy-acetylene cutting processes are all thermal cutting methods. Each method has distinct advantages for particular applications and materials. The primary function of each device, however, is to introduce thermal energy into the work piece. While each employs a different technology to do so, the objective, in this case, is to introduce enough thermal energy into the work to quickly bring it molten state then expel the material from the kerf. Expulsion of the slag is accomplished by jetting a high pressure gas to the molten region.

As is currently being used, oxy-acetylene cutting equipment has proven itself over many years as being an inexpensive, dependable, relatively efficient method for metal removal. Acetylene and oxygen gas are mixed in the cutting torch to provide the preheat exiting small annular jets on the nozzle. A centrally located oxygen jet is appropriately activated to expel the slag from the heated region. Oxy-acetylene cutting torches operate at approximately 6000 °F.¹ Manual cutting speeds can range from 12-14.5 inches-per-minute (ipm) on 1/2 inch carbon steel. Automated cutting can increase speeds up to 50 percent of typical manual cutting.

A typical equipment set is generally consists of gas bottles, regulators and hose, torch, and safety items for the operator such as goggles, gloves and aprons which makes the system portable requiring only gas refill and occasional tip cleaning or replacement to remain operational. The speed at which manual cutting can be accomplished is proportional to the material thickness and the experience of the operator.

Plasma arc cutting systems generate a high current electrical arc to introduce thermal energy into the workpiece. The current is delivered through a cable to a tungsten or hafnium cathode centered in a tubular nozzle constricted at the tip to form a narrow passage. Gas is introduced into the nozzle, where it flows past the electrode to a point on the workpiece (anode). When the arc is started it extends through and beyond the nozzle to the work. The gas traveling through the passage is heated and quickly expands into a high speed plasma jet generating temperatures in the range of 50,000 °F.² The molten material is flushed away by the high speed jet.

Plasma arc cutters are available in many capacities and cutting speeds increase with output amperage. Cutting speeds for 1/2" carbon steels range from 18-25 ipm at 80 Amp (A) output up to 70-80 ipm for 400 A units. These systems can be operated manually or automated similarly as other cutting methods. These systems require between 12 kW to 40 kW of electrical power and a source of compressed air or bottled oxygen.

Lasers have become more prevalent in industry in recent years. They are being used for many types of cutting and welding applications. Lasers deliver intense heat by generating a narrow beam of monochromatic, coherent light in the visible, infrared, or ultraviolet parts of the spectrum. Many factors affect the successful implementation of lasers for industrial purposes. Low power efficiencies, cooling requirements, delicate optical alignments have relegated most laser applications to fixed facility, repetitive function tasks.

Generally, lasers are being used to perform extremely intricate or precise work and most do not exceed the 2000 Watt range. CO₂ and YAG are the most widely used types of industrial lasers. CO₂ lasers are being built in the 10,000 W to 40,000 W range for specialized industrial applications which would be capable of performing very rapid pipe cut off operations, however, the cost, operational overhead, sensitivity, and numerous safety issues must be thoroughly addressed. Most industrial facilities employ a laser safety engineer dedicated to ensuring proper guidelines and precautions are enforced.^{3,4}

RF and ultrasonic sources of thermal energy have not been widely applied to metal fabrication. Low power efficiencies, specialized setups, environmental effects, and limited material applicability have confined most RF and ultrasonic uses to plastic fabrication.

3.3 Chemical Cutting

Chemicals have been used for a number of years for cutting metals in industrial applications. Perhaps, the most common form of chemical cutting is the chemical "machining" or etching of thin metal sheets. The process basically involves applying a chemically inert masking compound to the work in areas that are not to be cut. Submerging the piece into a highly caustic bath chemically dissolves the unprotected regions. This process is relatively slow and requires specialized facilities and safety requirements.

Thermit has been used for many years primarily for welding of large structures or equipment. An aluminum powder is mixed with an oxide of the metal to be welded. When heated an exothermic chemical reaction is initiated generating intense heat converting the metal oxide to pure metal while generating an aluminum oxide residue. Cutting with thermit is possible, but delivering a high speed gas to expel the slag can displace the powder mixture not making for a very practical application. Other chemical methods exist but have not been implemented with great success. Except under rare circumstances, the hazards in handling such materials often outweighs the benefits.

4.0 ELCAS(M) Pile Cutting Application

The 3000 ft ELCAS(M) is designed to be installed in seven days or less involving numerous equipment and personnel working in a precise, regimented manner. As the ELCAS(M) is assembled from the shore outward, equipment, material and personnel crowd the work area. The system was designed to be installed with limited support equipment i.e. forklifts, cranes, welding and cutting equipment, lighting, electrical power, etc. The rapid pipe cutoff technology developed must have minimal impact on simultaneous operations and support equipment logistics. Thus, the system must be fast, portable, and safely maneuverable in the highly congested work area.

As shown in section 3.0 many technologies are available for cutting steel. However, each has specific benefits for different applications and environments. In the case of the ELCAS(M), speed and safety take priority over precision and quality of cut. This eliminates most toothed shearing or sawing methods. Though they provide excellent cut quality, the relatively slow (approximately 3 ipm) cutting speed would require over 25 minutes to cut a 24 inch diameter pile in addition to setup time. Multiple cutting elements would only provide modest increases in speed while driving up the complexity of the device.

Single pass and rotary shear devices are conceivable to perform the pile cutoff operation. Several obstacles would have to be overcome for the successful implementation of these methods. This equipment typically operates using hydraulic power thus requiring the addition and associated logistics requirements of a hydraulic power unit (HPU). Rotary shear on large diameter sections is usually accomplished by rotating the work (the pipe) inside the stationary shear. A method of rapidly traversing the shear around the pipe capable of sustaining the large system forces would have to be developed. Also, several revolutions would be necessary and a method of preventing the hydraulic lines from becoming twisted around the pile would have to be addressed.

Single pass shearing of the piles would require a minimum of several hundred tons of hydraulic power due to the large shear area of the piles. The device would be extremely heavy and cumbersome requiring the assistance of forklift or crane for setup. In either case, cutoff times would be several minutes in addition to setup time.

Explosive shape charge shearing and chemical cutting of the piles are possible but the congested work environment of the ELCAS(M) is less than ideal. In addition to the operational safety precautions that would have to be enacted, special handling, storage and trained personnel are needed. Similarly, laser cutting systems are more than capable of performing the cutoff operation under the right conditions. But packaging the laser, power supply, chiller unit, etc. for the field environment and developing the required beam delivery robotics for the ELCAS(M) application would be cost prohibitive.

Two technologies, oxy-acetylene and plasma arc, were determined to be most applicable to the ELCAS(M) pile cutting application. These methods are similar in operation providing fast

cut capability and are easily made portable and mobile. Each may be used with existing ELCAS(M) support equipment with minimal maintenance and logistics impact.

5.0 Technical Approach

CSI proposed a Rapid Pipe Pile Cutter (RPPC) System that will be integrated with existing handling and support equipment to reduce cost and logistics impact. CSI investigated two approaches to deliver a cutting technology, assisted only by one unskilled laborer, to rapidly cutoff up to 30 inch diameter steel pilings while reducing or eliminating the time needed for crane assistance. The technical approach was developed using the following parameters:

- Reduce or eliminate crane time during pile cutting procedures.
- Use only one unskilled operator.
- Integrate proven, field tested, technology.
- Provide safe cutting procedures.
- Minimize maintenance and logistics impact.
- Maximize the use of existing support equipment and infrastructure.
- Improve overall material handling.
- Provide for future dual use options (i.e. cutting and welding).
- Develop a modular environment for system upgrades.

5.1 Multi-head Oxy-acetylene Torch Array (MOTA) Rapid Pipe Pile Cutter (RPPC)

Oxy-acetylene cutting equipment are part of the equipment contingent that is deployed for the assembly of the ELCAS(M). Developing an automated device based on this technology would have little impact on existing logistics requirements. A cutting system concept was investigated which positioned an array of oxy-acetylene cutting torches around the pile as shown in Figure 2. The torches are fastened to an articulating "clamshell" carrier/guide which allows the device to be placed around and removed from the pile. The unit is comprised of several traditional cutting torch modules positioned in a circular array around the pile and are easily adjusted for any diameter pipe. Since very low forces are required, a simple spring and closed loop hydraulic damper are used to translate the torch array around the pile. This travel mechanism is activated by "cocking" the handle and closing the metering valve. The amount of angular travel is dependent on the number torches in the array.

The ISO VIEW of Figure 2 shows the Multi-head Oxy-acetylene Torch Array (MOTA) concept in an operational mode. The MOTA assembly is integrated into a lightweight, dedicated cart which carries the gas bottles/regulators, provides the unskilled operator a control panel with instructions. The portable unit is fitted with uni-directional caster wheels which provide a self-centering feature. Lighting the torches is accomplished using solid state crystal spark generators which do not require electrical power. These devices are widely used in consumer gas grills and commercial flame cutting machines. The gas delivery rates and mixture, travel speeds, etc. are preset and are presented to the operator as on/off controls.

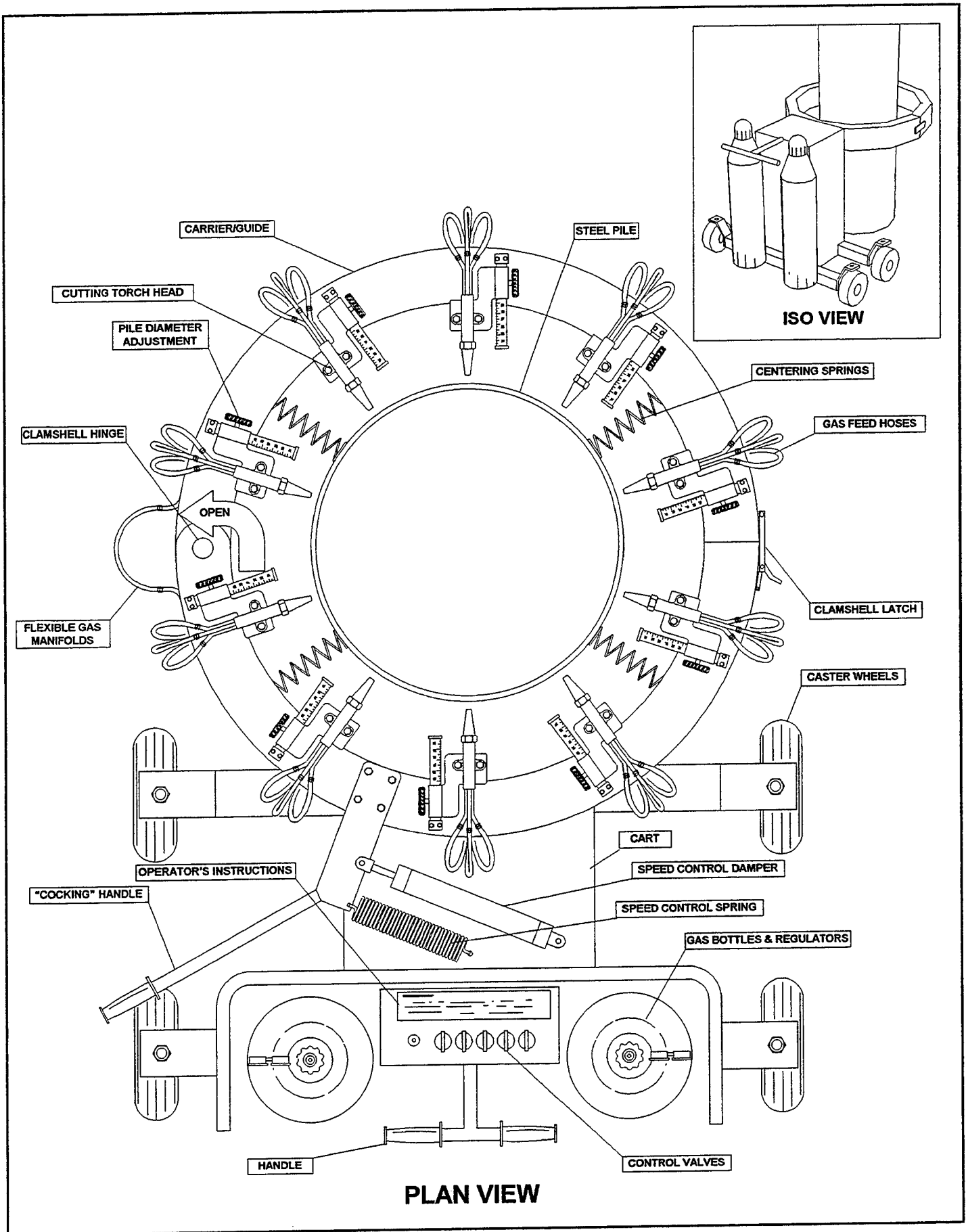

Figure 2 - Multi-head Oxy-acetylene Torch Array (MOTA) RPPC concept for the ELCAS(M).

Appropriate safety equipment, garments and precautions are already established for this type of cutting technology. The MOTA is of relative small size providing unobstructed access to the roadway. The unit does not require additional power supplies, generators, exotic gases, special handling or high maintenance to remain operational. However, future adaptation for pile welding is not practical. Thus, a similar approach was developed utilizing a plasma arc unit as the basis of operation.

5.2 Automated Plasma Arc (APA) Rapid Pipe Pile Cutter (RPPC)

Plasma arc cutting technology has been proven over decades of use. The advantage of plasma arc cutting versus oxy-acetylene cutting technology is speed, cut quality, and welding capability with the addition of a wire feed device. As shown in section 3.2 plasma arc generates temperatures up to 50,000 °F as compared to 6,000 °F for oxy-acetylene methods. Increased temperatures bring the work to a molten state much more rapidly and thus allows greater piercing and cutting speeds.

The Automated Plasma Arc (APA) Rapid Pipe Pile Cutter concept is similar in configuration to the MOTA concept. A plasma arc torch is substituted for the oxy-acetylene torch array. Typical plasma arc systems using bottled oxygen or compressed air can deliver cutting speeds between from 15 ipm to over 100 ipm, therefore, a single plasma arc torch can deliver the same speed as ten gas torches. Depending on output amperage, these systems require the use of at least 15 kW of three-phase electrical power.

Figure 3 illustrates the basic components of the APA concept. The APA system is composed of a single plasma arc torch attached to an automated carrier. Like the MOTA concept, the guide/carrier are designed in a "clamshell" fashion to allow easy placement around and removal from the pile. Since a single plasma arc torch must travel at least the circumference of the pile (360°), a motor driven carriage and track translate the torch around the pile and returns it to a "home" position when the cut is complete.

The APA system concept is composed of the plasma arc unit, power/gas leads, logic control box, drive unit, track and the clamshell cart unit. The operator is provided a control panel on the cart to operate the system.

Operationally, the APA concept requires few steps. An operational scenario would be as follows: The pile is supported during the cutoff operation. The operator wheels the APA cart near the pile and opens the carrier/guide clamshell. The unit is positioned against the pile and the clamshell is closed; centering the unit around the pile. The operator latches the clamshell closed and attaches the magnetic ground lead to the lower section of the pile. The operator switches the unit into automatic mode and presses the "START" control. After a short preset piercing time, the plasma arc torch will automatically travel around the guide cutting the pile. At the end of the cutting cycle the torch carrier trips a switch to extinguish the arc and rapidly retract the torch carrier to its original position. The operator will then open the clamshell, wheel the unit clear of the pile, and indicate when it is clear to extract the cut section.

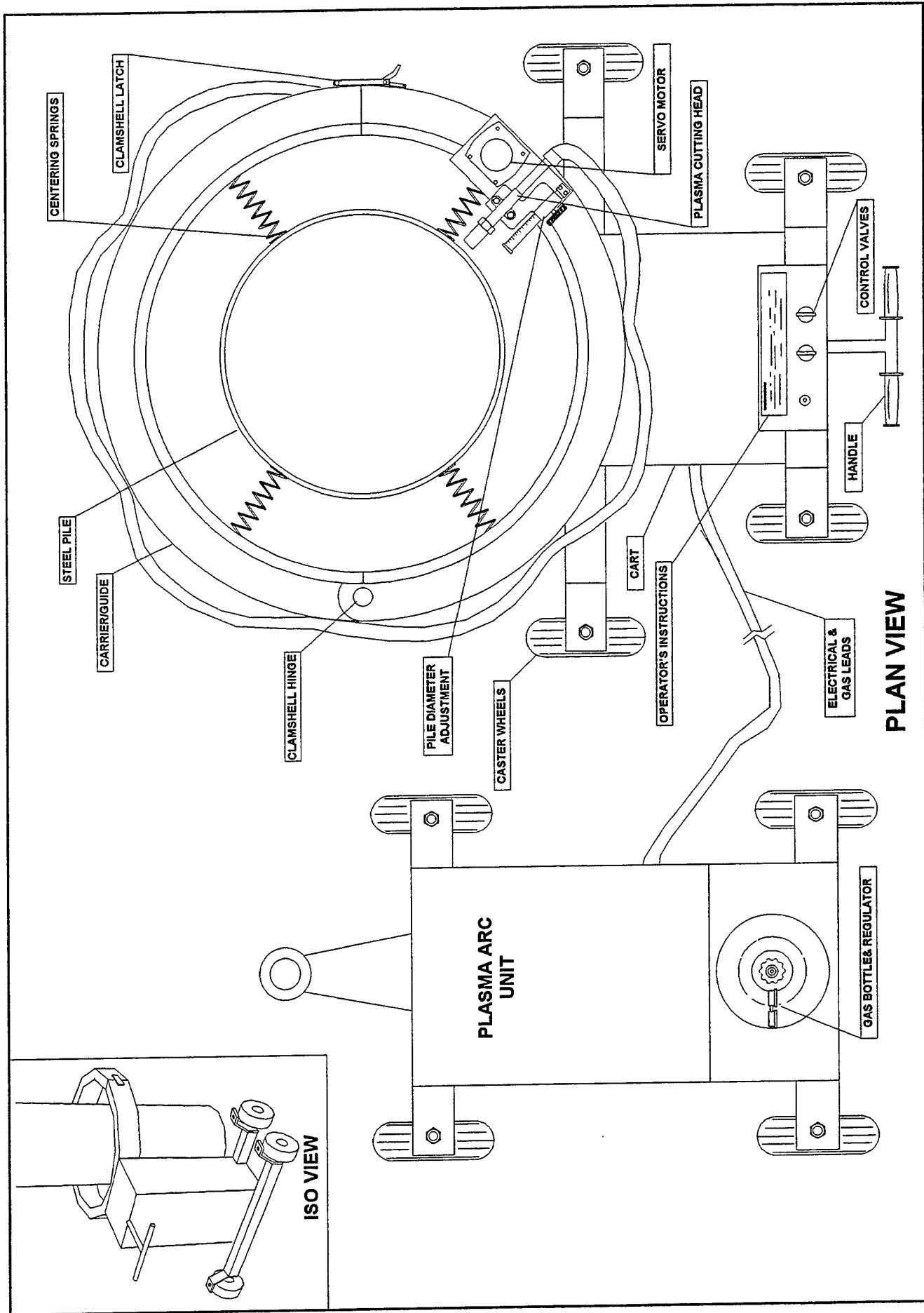

PLAN VIEW

Figure 3 - Automated Plasma Arc (APA) RPPC concept for the ELCAS(M).

The estimated cutting time for the 200 Amp APA concept is between 56 seconds and 65 seconds. Setup and removal should be able to be performed in under 60 seconds; delivering a total operational time in the 2 minute range. Faster cutting times can be achieved by increasing the number of plasma arc torches. By adding another torch/carrier to the unit and limiting the angular travel to approximately 180°, the cutting speed is increased by a factor of two.

The APA RPPC concept takes advantage of electrical power not only for cutting but to provide the operator an automated, fast pile cutting technology. Cutting carbon steel does not require exotic gases, compressed air or bottled oxygen currently in the ELCAS(M) equipment inventory can be used. Safety precautions and equipment are the same as traditional arc welding gear currently in use. Additionally, plasma arc machines can be dual use equipment providing for future integration of welding capabilities.

5.3 Hydraulic Pile Handler (HPG)

In any fabrication process efficient material handling is often the key to successful, timely execution of the task at hand. Under the current ELCAS(M) deployment procedures, the crane is performing several time consuming tasks. One such function is supporting piles during the cutting operation and subsequently lowering the cut section to the roadway where a forklift truck taxis it back to shore.

A review of the ELCAS(M) assembly procedure lead to the development of a pile handling concept to minimize or eliminate the crane from pile cutting operations. The ELCAS(M) equipment contingent has a least three forklift trucks or container handlers which ferry piles, causeway sections, and other material and equipment from shore. A simple, two-axis hydraulic pile gripper (HPG) device, similar to that shown in Figure 4, would allow a forklift type vehicle to support and handle the steel piles during and after the cutting procedure.

The HPG is a self-contained, rapidly deployable, portable pile handling aid. The basic unit is composed of a two sets of hydraulically actuated grippers which are mounted on gimble which permits the pile to be hydraulically rotated for transport. The system has a gripper control module which can be rapidly mounted/dismounted to forklift. Power is delivered to the gripper via auxiliary hydraulic take-off ports on the forklift. The hydraulic system requires only two quick-disconnect couplings and quick-release mounting of the gripper control valve module for operation. The HPG unit attaches to the existing forks by "driving the forks" into fork hooks on the unit. A safety chain is provided and attached to fork support structure.

A typical operational scenario is illustrated in Figure 5 and is described as follows: While the crane is driving piles previously delivered, the forklift operator drive-up installs the HPG unit and attaches the safety chain. The operator makes two quick-disconnect hydraulic connections and mounts the control module to a pre-installed bracket. The operator travels to the pile to be cut and raises the HPG above the cut zone and grips the pile. The RPPC operator performs his cutting function and, when all is clear, signals the forklift operator to remove the cut section. The operator then lowers and rotates the pile for transport and taxis the cut section to shore. He

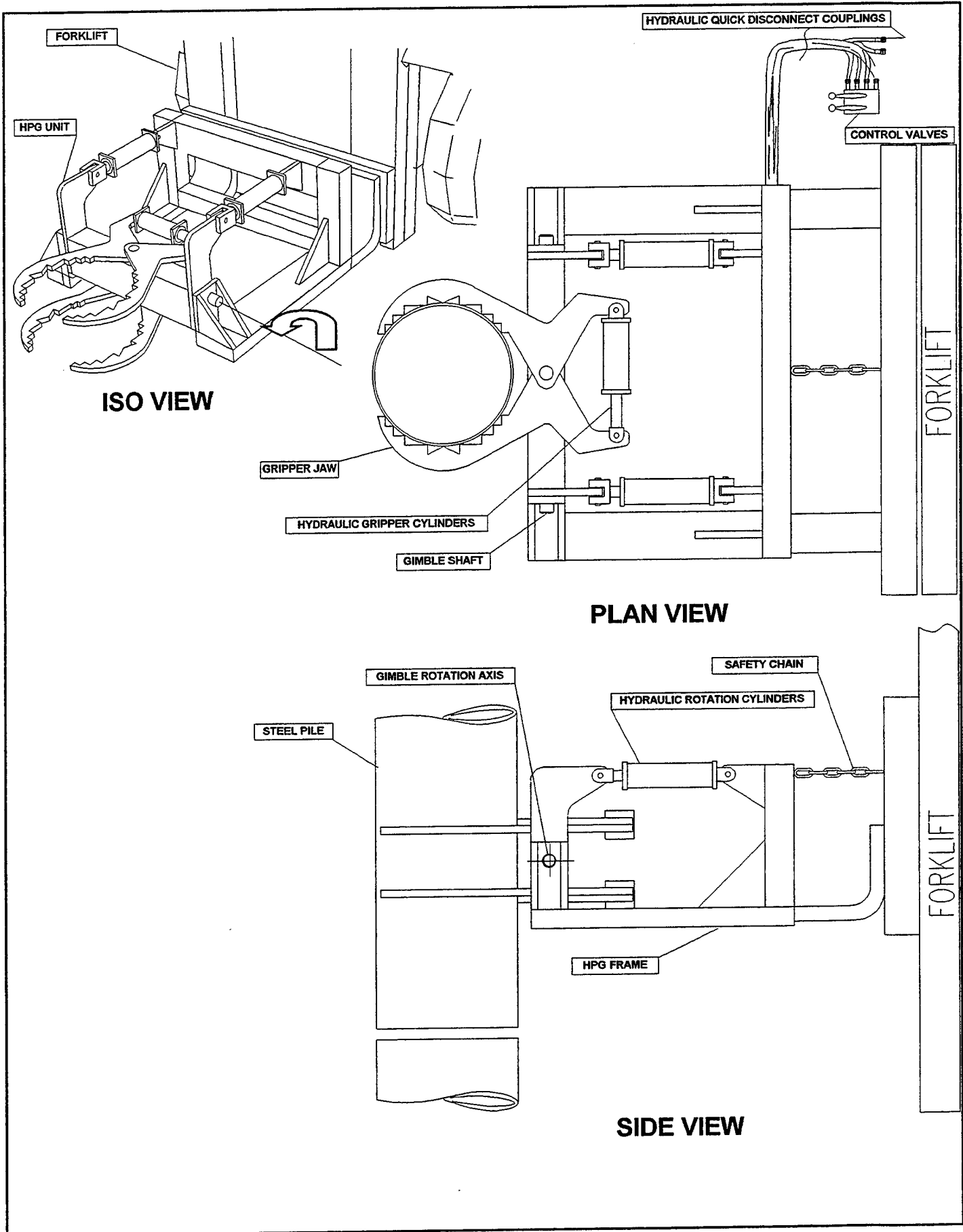
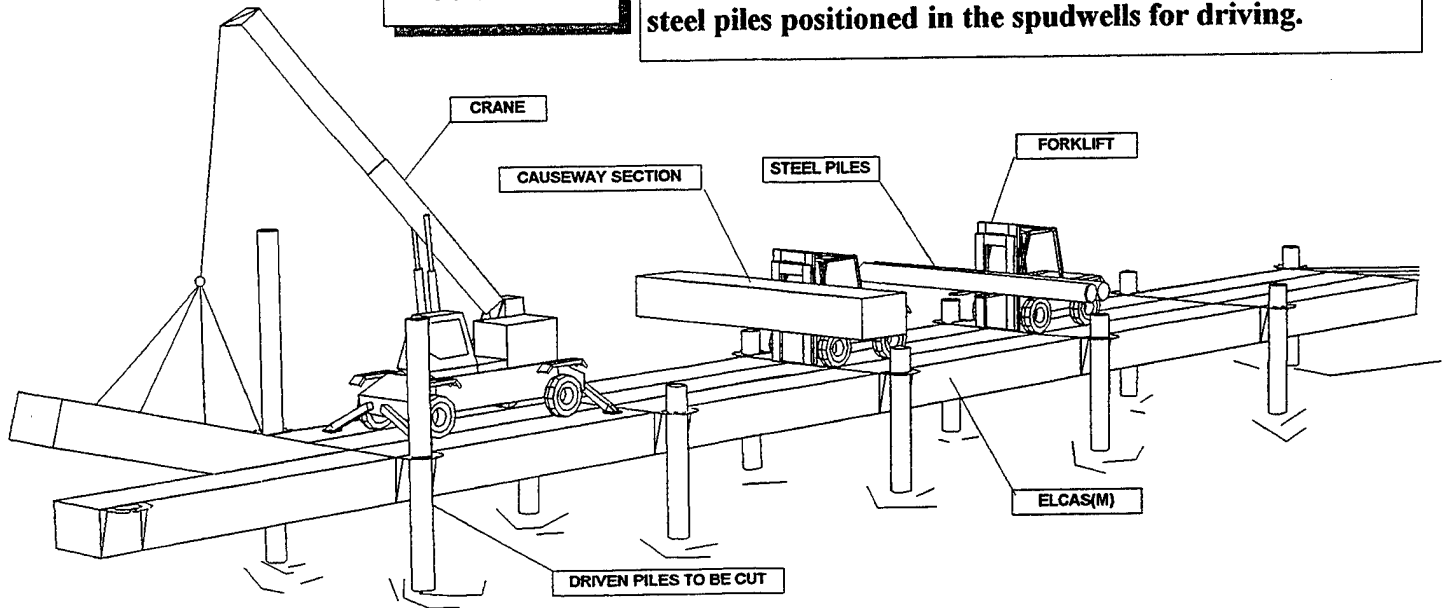

Figure 4 - Forklift Mounted Hydraulic Pile Gripper (HPG) concept for the ELCAS(M).

STEP 1

The ELCAS(M) causeway sections are assembled and steel piles positioned in the spudwells for driving.



STEP 2

While the piles are being driven, the RPPC is positioned around the pile. The forklift mounted HPG then grasps and supports the pile during cutting.

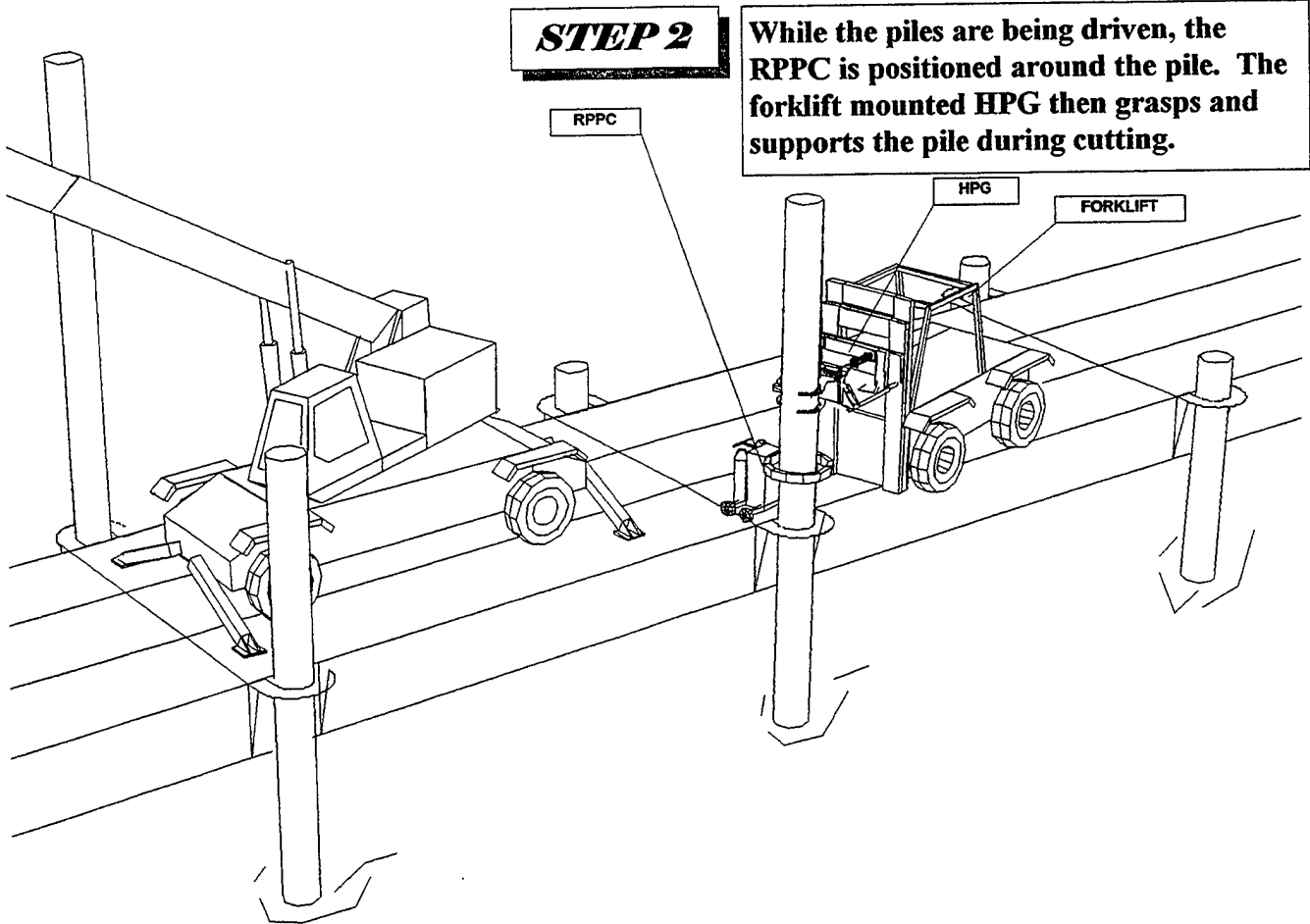
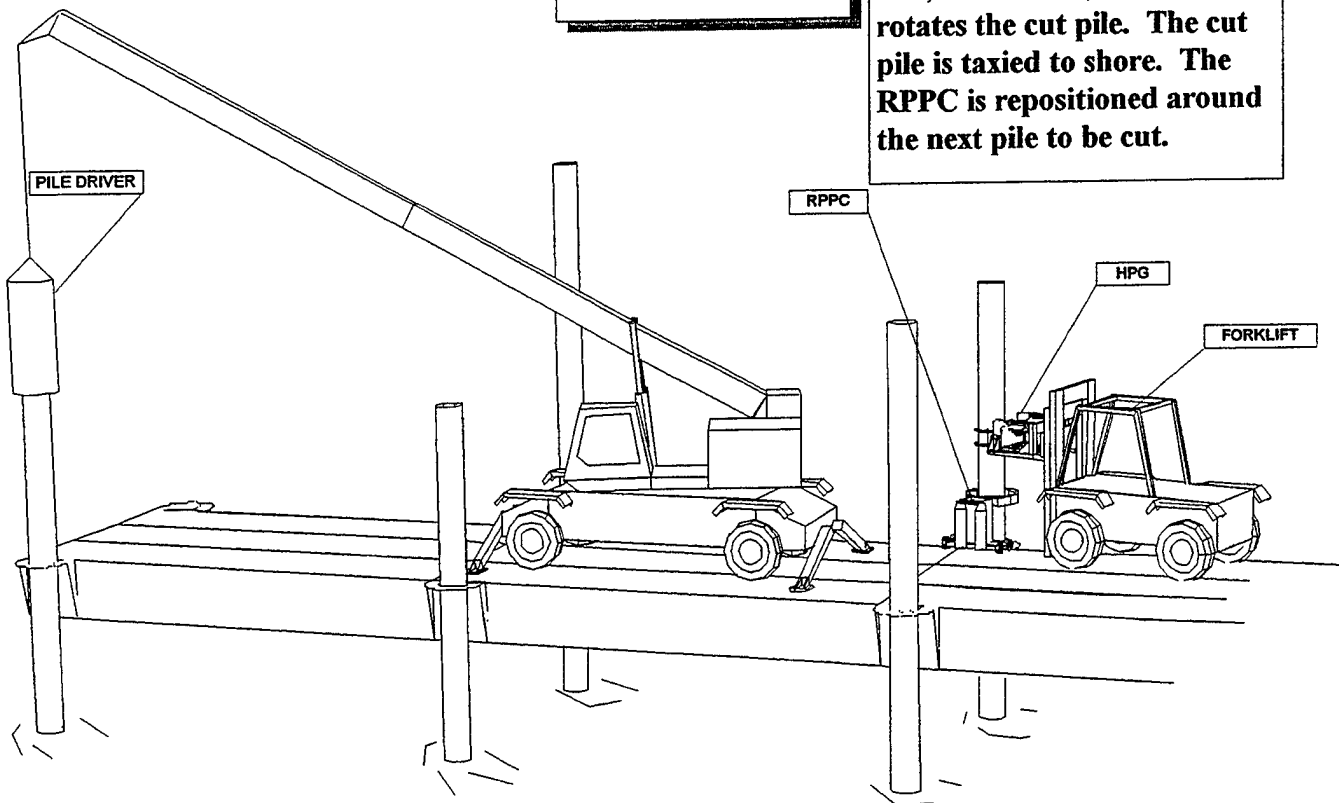

Figure 5 - Operational Concept

STEP 3

The forklift mounted HPG lifts, maneuvers, lowers, then rotates the cut pile. The cut pile is taxied to shore. The RPPC is repositioned around the next pile to be cut.



STEP 4

The forklift/HPG returns to assist the RPPC operator. Once the cutting operation is complete, the cut pile is delivered to shore (as in STEP 3) and the HPG disconnected. The forklift then brings the next causeway section and the cycle repeats. The crane is eliminated entirely from the pile cutting process.

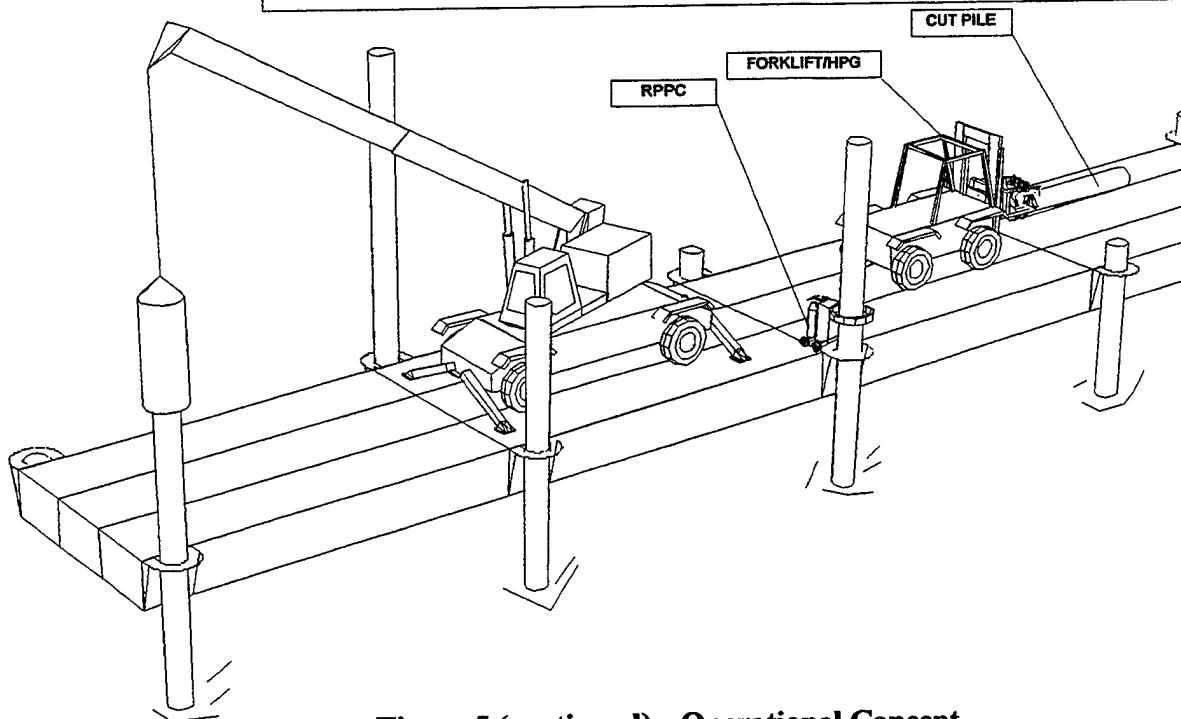

Figure 5 (continued) - Operational Concept

repeats the gripping and transport if additional piles are to be cut; or disconnects the HPG and brings the next causeway section from shore and waits for the pile driving to commence.

Under the current procedure, causeway sections and piles cannot be delivered until the piles are cut and removed. By using the HPG coupled with the APA RPPC it is feasible that two piles may be cut, removed, and new material staged while the crane drives two new piles. Additionally, the HPG may be used to handle pile unloading, welding and staging functions on shore.

6.0 Concept Development and Analysis

6.1 User Input

CSI traveled to Amphibious Construction Battalion #2 (ACB2), Little Creek, VA to gather information on the ELCAS(M) system and obtain user feedback on the proposed pile cutting and handling concepts.

ACB2 uses three fork lift trucks to assemble the ELCAS(M). The Rough Terrain Container Handler (RTCH), 50,000 lb. capacity; Rough Terrain Quick Coupled (RTQC), 15,000 lb. capacity; and the Rough Terrain Extendible Boom (RTEB), 6,000 lb. capacity.⁵ The RTEB is used for container unloading and staging. The RTQC performs various support functions. The RTCH is used to handle causeway sections and piles on shore and taxi materials to the crane. The RTCH is outfitted with a receiver frame which mates to either a container or the dedicated pile bin. Pile preparation, splicing are generally accomplished on shore.

The standard 24 in. pile length is 40 ft. The RTCH is capable of transporting piles consisting of two welded sections totaling 80 ft. The reach of the crane limits length of the pile. In the event that a pile is required in excess of 80 ft., splicing must be performed on the causeway. Prior to splicing, the ends of the piles must be beveled for welding. Splicing and beveling are accomplished with a series of dedicated positioning fixtures and oxy-acetylene bevel cutter. However, the current equipment does not permit continuous 360° beveling. The pile must be rotated. Excessive pile distortion hampers these operations. The piles become out-of-round due to handling or sagging.

Pile cutting is performed using manual oxy-acetylene torches and can take 15-30 minutes to perform depending on conditions. The approximate cut pile height cannot extend beyond 5 ft. above the roadway. Piles on the pier head must be cut below the roadway surface. The cut piles are returned to shore for beveling and splicing. Upon dismantling of the system, piles are cut and spliced in lengths of 40 ft. for transport.

The personnel of ACB2 were receptive to cutting and handling concept developed by CSI. They indicated that a dual use system which was capable of performing cutting and welding procedure would be useful both on the causeway as well as in the pile staging area. ACB2 provided valuable insight as to the intricacies of successfully deploying the ELCAS(M).

6.2 Design Parameters

ACB2's and NFESC's input was used to formulate the operational parameters that the full scale RPPC and HPG systems must perform within. The following parameters were used as the basis for developing the system concepts:

1. Perform the cutting operation in one to two minutes
2. Cutting speed can be decreased if HPG can be used for majority of cutting operations
3. Safety takes precedent over speed
4. Integrate the systems with existing equipment as much as practical
5. The RPPC must maneuverable
6. Minimize electrical power requirements
7. Perform bevel cutting operation during cutoff to save this step on the cut pile
8. RPPC requires only one operator
9. Relieve the crane of the pile cutting burden for the majority of cutting operations
10. Typical cut pile length is less than 40 ft.
11. Cut pile length can exceed 40 ft.
12. RTQC is best suited for HPG operations
13. HPG must install/uninstall quickly
14. Incorporate commercially available components as much as practical

6.3 Full-Scale System Requirements

An investigation was performed to determine the requirements of full scale RPPC and HPG systems to meet the design parameters established.

6.3.1 RPPC Requirements

The 24 in diameter pile has circumferential surface distance of 75.4 in. Performing the cutting operation in one to two minutes dictates cutting speeds in the range of 70 to 80 ipm considering the necessary procedure to engage the pile, perform the cut, and return the torch to the "home" position. A market survey of commercially available plasma arc cutting systems was performed to determine the capabilities of these systems. System capable of generating cutting speeds of 70 to 80 ipm in output current from 175 A to 200 A. Figure 6 shows the typical cutting speed versus steel

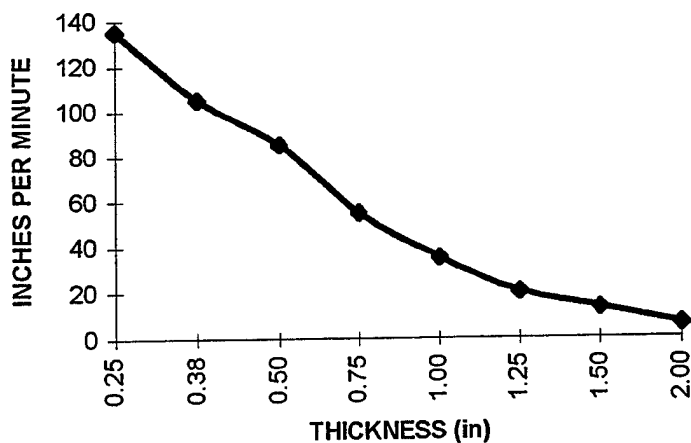

Figure 6 - 200 Amp Cutting Speed vs. Material Thickness

thickness for 200 A plasma units.

Most units permit use of multiple gases for cutting steel. Gases include compressed air, nitrogen (N₂), and oxygen (O₂). Plasma gas consumption is approximately 1.1 scfm while shielding gas consumption is approximately 5.3 scfm. Welding would require use of an inert shielding gas such as argon to prevent oxidation and contamination of the weld.

The electrical supply requirements for units with these output currents is approximately 25 kW, three phase. NFSEC indicated that the generators fielded for the ELCAS(M) do not have excess capacity to power plasma units of this size. It was suggested that cutting speed and, thus, power requirements could be reduced if the HPG could be used for the majority of the cutting operations. A self-contained power unit could be added. The RPPC would be used in close proximity to the crane. And since the crane moves only outward while assembling the roadway, the unit could be pulled either behind or along side the crane without impeding its operations. Figure 7 shows crane and its relative position to the RPPC and the towed power unit. If compressed air is used a small compressor could be incorporated into the power unit.

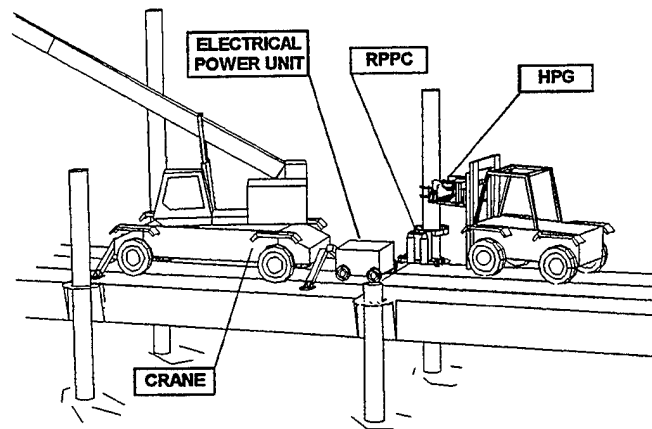

Figure 7 - Towed Electrical Power Unit

Torch carriers and drive units are commercially available for adaptation into the RPPC unit. Most units deliver speeds up to 60 ipm. Providing cutting speeds of 70 to 80 ipm and a rapid return mode of 160 ipm requires modification. Typically these systems use a maximum of 200 W electrical power.

Structurally, the RPPC chassis must only support the torch carrier/drive unit, plasma unit and gas bottles (if used). The total weight of the RPPC unit using a 200 A plasma unit was determined to be approximately 400 lb.

6.3.1 HPG Requirements

The proposed concept for providing pile handling capability was a single axis gripper mounted on a gimble axis. The gripper is configured to grip the pile just above the cut zone. The gimble permits pile rotation on an axis parallel to axles of the forklift. The concept was developed after considering other methods of manipulating a cut pile. For example, as shown in Figure 8(a), gripping the pile at the approximate midpoint of the cut section will not permit the pile to be rotated about the y-axis without contacting the forklift as it is lowered. Rotating the pile about the x-axis as shown in Figure 8(b) introduces lateral inertial forces at the extended height and

could cause the forklift to tip sideways if the pile is gripped unsymmetrically. The proposed concept resolves the inertial effects about the y-axis; parallel to the forklift axles, loading the forklift as a conventional load.

The operation of the HPG would grip the pile approximately 2 ft. above the cut line. The cut would be performed freeing the cut section. The forklift operator would slowly back away from the pile and lower the forks. The operator is then capable of maneuvering; turning the forklift towards the shore. The pile can then be rotated horizontally for transit. Once on shore, the forks are lowered further and the gripper jaws opened to release the pile.

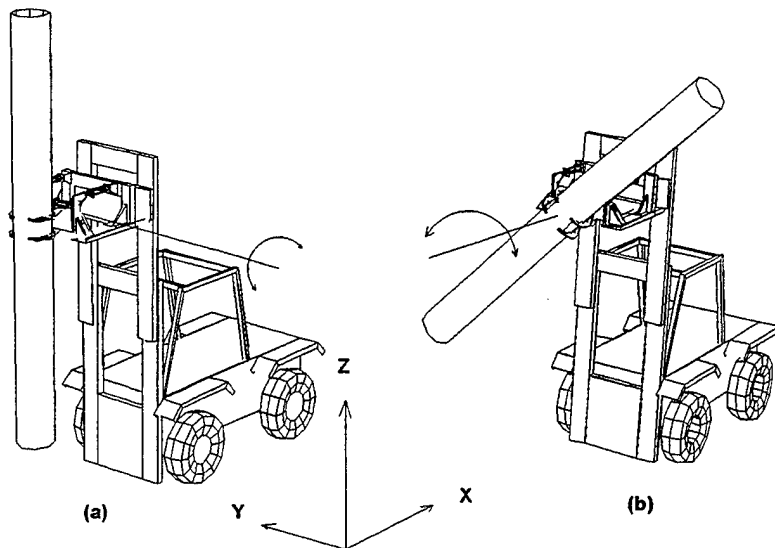

Figure 8 - Pile Handling Considerations

The RTQC was determined to be the best suited of the three available forklift trucks for use with the HPG system. Use of the RTCH is not practical due to its other duties and the extensive rigging required to adapt an HPG type device. The RTQC has a lift capacity of 15,000 lb. Calculations were performed to determine the maximum pile length that could be carried using without exceeding the capacity of the forklift. Figure 9 shows the parameters constraining the lift capacity of the RTQC. The maximum length pile that can be manipulated with the RTQC/HPG is approximately 36 ft. Cut pile lengths greater than 36 ft. would require assistance from the crane and handling the section with current procedures.

The HPG is designed to adapt to the forklift truck's existing hydraulic system via hydraulic take-off ports (HTO) using quick-disconnect couplings or by adding two valve bodies to the existing control valve stack. Tapping into the HTO is least intrusive to RTQC system. However, modification of the valve stack can be accomplished using standard components available from the manufacturer and would eliminate the hydraulic control lines since the standard system is used to power electrically operated pilot valves. Only hydraulic supply and return lines would be required. The hydraulic connections and electrical control connection could be made at the fork support structure. The RTQC's hydraulic system delivers a flow capacity of 61 gallons per minute (gpm) with maximum relief pressure is set at 2,800 psi.⁷ This is ample supply and pressure for full scale HPG operations based on the requirements of the model system.

Excessive gripping pressure on the pile could cause permanent pile distortion. Grip jaws configured as in Figure 4 would impose several point loads on the pile limiting the gripping pressure that would be sustainable without causing permanent deformation. A jaw design was

$$M_{\max} = 15,000 \text{ lb} * 7.6 \text{ ft} = 114,000 \text{ ft-lb}$$

$$W_{\text{pile}} = 126.25 \text{ lb/ft} * 36 \text{ ft} = 4,545 \text{ lb}$$

$$M_{\text{pile}} = 4,545 \text{ lb} * (17 \text{ ft} + 7.6 \text{ ft}) = 111,807 \text{ lb-ft}$$

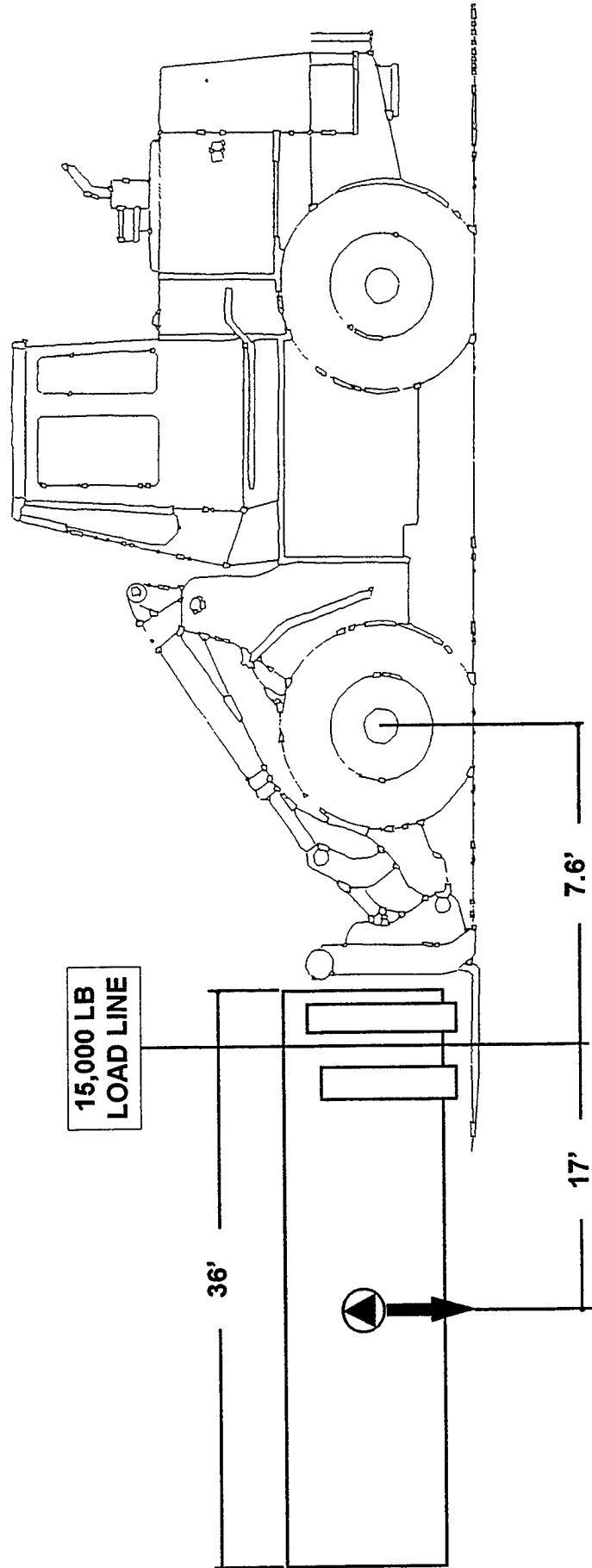

Figure 9 - Moment Limit of RTQC Forklift

developed to distribute the gripping pressure over a larger area (see Figure 10). Section 6.4.5 details the analysis of this design for the demonstration model. Given those results it is practical to scale this design to handle up to 36 ft. long piles without causing permanent deformation.

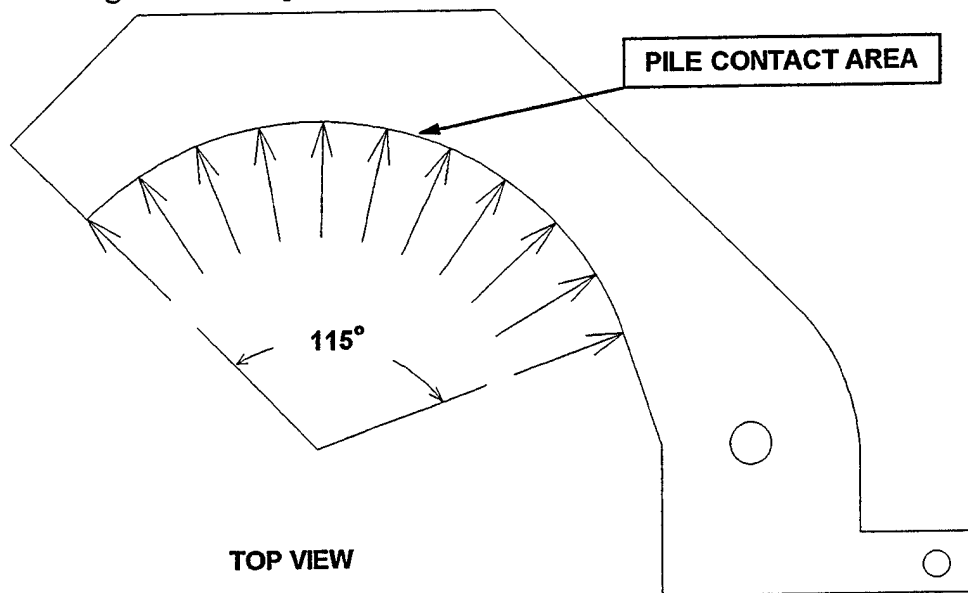

Figure 10 - Distributed Pressure Jaw Design

6.4 Demonstration Model Design and Analysis

CSI proposed to verify the RPPC and HPG concepts and principals of operation through the design, analysis, fabrication and testing of demonstration model systems. The systems will be used demonstrate that a 24 in. diameter pile can be cut using an automated plasma cutter and that a 10 ft. section of the same pile can be handled using the principals of the HPG concept.

6.4.1 Model RPPC Design

The model RPPC system is based around the ESAB PCM-1000i plasma arc cutter as illustrated in Figure 11. The PCM-1000i has an output amperage of 80 A and uses compressed air as both plasma and shielding gas. According to the manufacturers data, the unit is capable of delivery cutting speeds of approximately 55 ipm on 0.5 in. carbon steel and is rated for material thicknesses up to 1.25 in. The PCM-1000i performance versus material thickness is shown in Figure 12. 220 VAC-3 phase electrical power is required to operate the plasma unit and draws 50 A at full load.

The torch is translated around the pile using a Weld Tooling Corporation BUG-5900-CGB drive unit and carriage and BUG-1210-34 ring rail track. The drive carriage is fitted with a panograph assembly which allows the torch to follow the contour of the pile. Bevel cutting is accomplished by rotating the torch to the desired angle in the torch holder. The drive unit is capable of translating the torch up to 60 ipm relative to the ring rail. The ring diameter is 36 in. which equates to an effective speed of 40 ipm for the 24 in diameter pile. The drive unit/torch

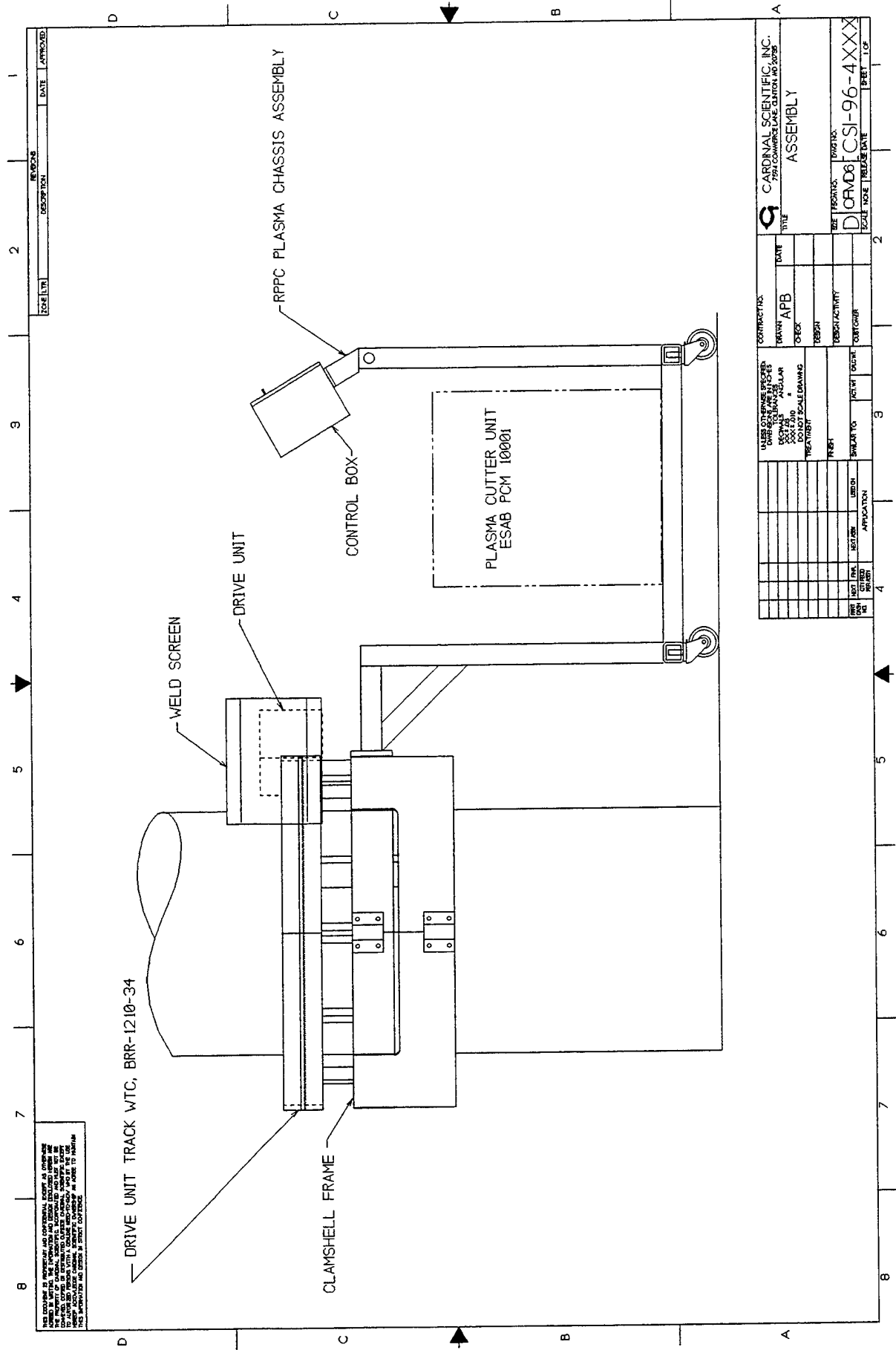

THIS DOCUMENT IS UNCLASSIFIED AND CONFIDENTIAL EXCEPT AS OTHERWISE INDICATED. IT IS THE PROPERTY OF CARDINAL SCIENTIFIC, INC. AND IS LOANED TO YOU BY THE COMPANY. IT IS TO BE USED ONLY FOR THE PURPOSES AND IN THE MANNER SPECIFIED BY THE COMPANY. IT IS NOT TO BE REPRODUCED, COPIED, OR TRANSMITTED IN ANY FORM OR BY ANY MEANS, ELECTRONIC OR MECHANICAL, INCLUDING PHOTOCOPYING, RECORDING, OR BY ANY INFORMATION STORAGE AND RETRIEVAL SYSTEM, WITHOUT THE WRITTEN PERMISSION OF CARDINAL SCIENTIFIC, INC.

CONTRACTING		DATE	
TRAVIN	APB		
OPER			
DESIGN		DESCRIPTION	
DESIGN ACTIVITY		COURTSHIP	
USER OR ENGINEER		SCALE	
DATE	SCALE	DATE	SCALE
DESIGNER		CHECKER	
REVISION		REVISION	
APPROVED		DATE	
TITLE		PROJECT	
G CARDINAL SCIENTIFIC, INC.		D ORVD08	
ASSEMBLY		CSI-96-4XXX	
SCALE		RELEASE DATE	
SHEET		OF	
1		1	

Figure 11 - Prototype RPPC System Design

assembly is enclosed with a protective welding screen to provide protection from incidental exposure to the plasma arc.

The track is supported by a "clamshell" frame fabricated from .375 in x 4.0 in 6061-T6 aluminum. Detailed drawings of the model RPPC system are contained in Appendix A. The frame is fitted with two 150 lb. capacity hinges to enable opening the unit. A 700 lb. capacity draw latch is used to retain the frame around the pile during operation. The frame is fitted with three centering studs

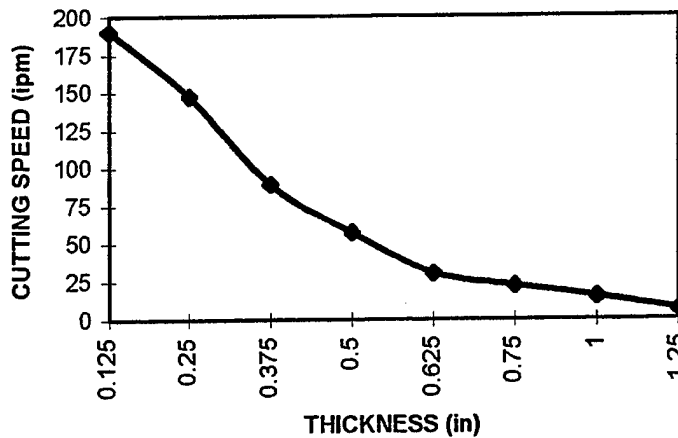

Figure 12 - ESAB PCM-1000i Plasma Arc Performance

which are preset for the pile diameter to be cut. The frame assembly attaches to a chassis constructed of 2 in x 2 in x 1/4 in wall steel tubing. Four 175 lb. commercially available caster are fitted to the chassis. The two rear caster wheel are fitted with brakes which permit the unit to be locked in position to prevent rolling. The PCM-1000i rests on the lower tubes of the chassis. The chassis is fitted with four 175 lb. capacity uni-directional caster wheels. A control box is fitted above the chassis handle and serves as an operators control panel and houses the control electronics. The control panel layout is shown in Figure 13.

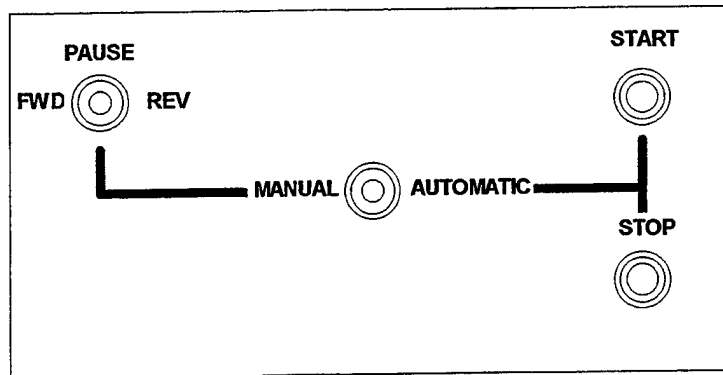

Figure 13 - Control Panel Layout

The BUG-5900-CBG drive unit is factory equipped with manual controls. The drive unit motor is 12 VDC and is speed controlled using an 8 VDC voltage divider potentiometer. Automation of the RPPC required disabling the factory control system and developing a control circuit to perform the cutting operation. The control circuit developed gives the operator the choice of manual two-direction movement of the drive unit or automated cutting with a rapid return. The circuit is illustrated in Figure 14. The control circuit provides the following features:

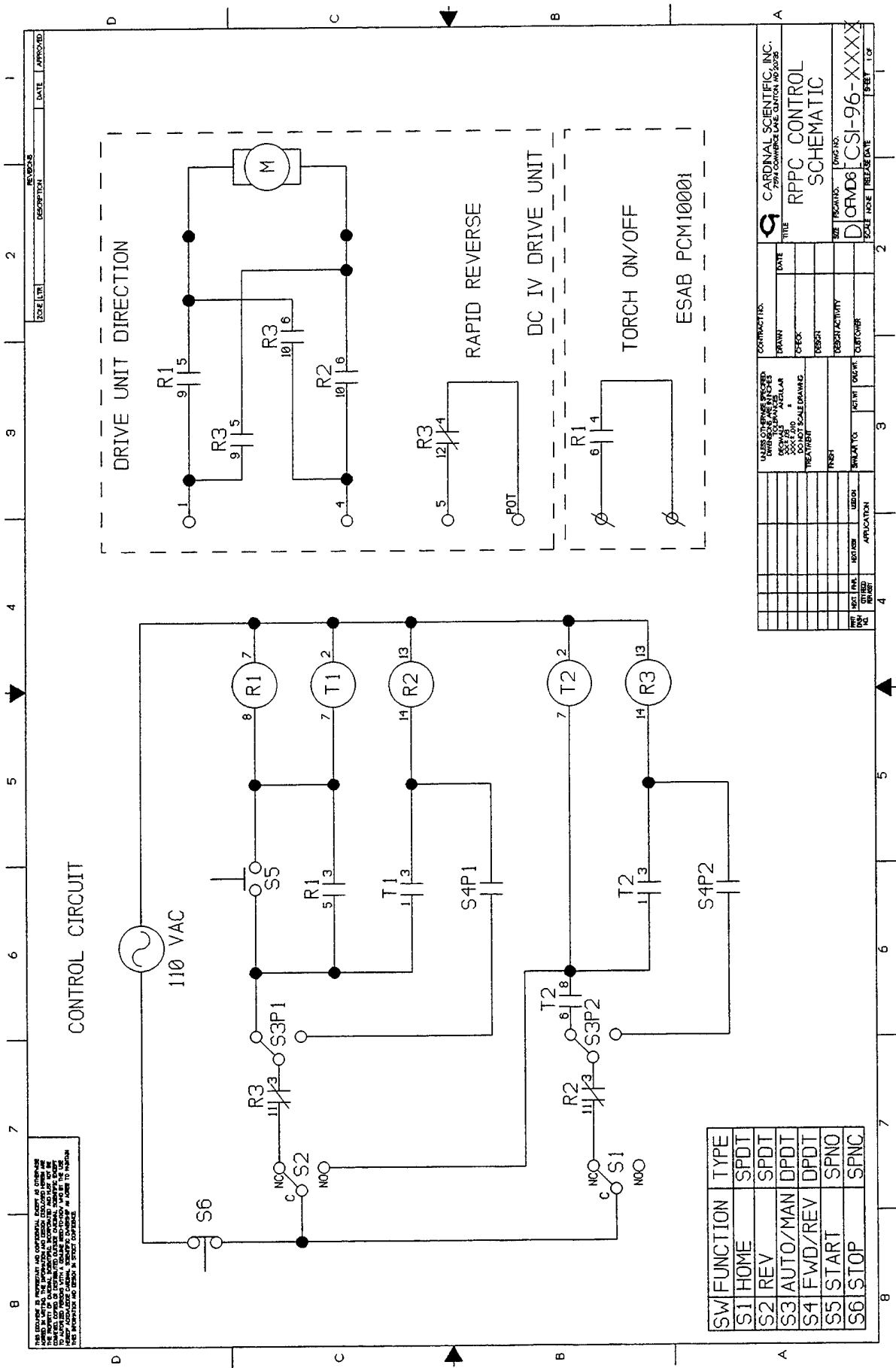

Figure 14 - Prototype RPPC Electrical Control System Design

Operator selects manual jog mode or automatic cutting mode

Automatic Cutting Mode

1. Operator presses the Start button
2. The torch is started and dwells for preset piercing time
3. The drive unit motor is started in the forward direction and travels around the pile at a preset speed
4. At the end of the cutting cycle, the torch extinguishes and forward is shut off
5. Drive unit dwells and engages high speed return to home position
6. System shuts off in home position
7. Operator provided with emergency stop during automated operation.

Manual Jog Mode

1. Operator selects forward or reverse jog direction
2. Jog is limited by home and reverse position.

The model RPPC is shown in Figure 15.

6.4.2 Prototype RPPC Analysis

The PCM-1000i is rated at 55 ipm for 0.5 in. carbon steel. The drive unit is rated at 60 ipm. However, the drive unit travels along the ring rail track which is of a fixed diameter of 36 in. The effective maximum cutting speed is proportional to the ratio of the pile diameter and the ring track diameter. The original specifications for this effort required the RPPC to cut 24 in. to 30 in. diameter pile. Figure 16 shows the relationship of cutting speed to pile diameter for performing a perpendicular cut.

The cutting speed of the RPPC while performing a perpendicular cut is limited by the drive unit. The theoretical output amperage of the PCM-1000i to prevent automatic arc extinguishing on a 24 in diameter pile is approximately 58 A. Figure 17 shows the theoretical output amperage settings versus pile diameter.

Bevel cuts are limited by the PCM-1000i. Common weld preparation bevel angles are approximately 30° from perpendicular. The effective material thickness is determined by:

$$T_{\text{effective}} = T/\cos(\theta) \qquad \text{Equation (1)}$$

where T = wall thickness, θ = bevel angle. The effective thickness for the 0.5 in wall pile is 0.6 in. Using Figure 12, the maximum cutting speed is limited to approximately 32 ipm. Figure 18 shows the theoretical maximum drive unit speed for 30° bevel cuts versus pile diameter.

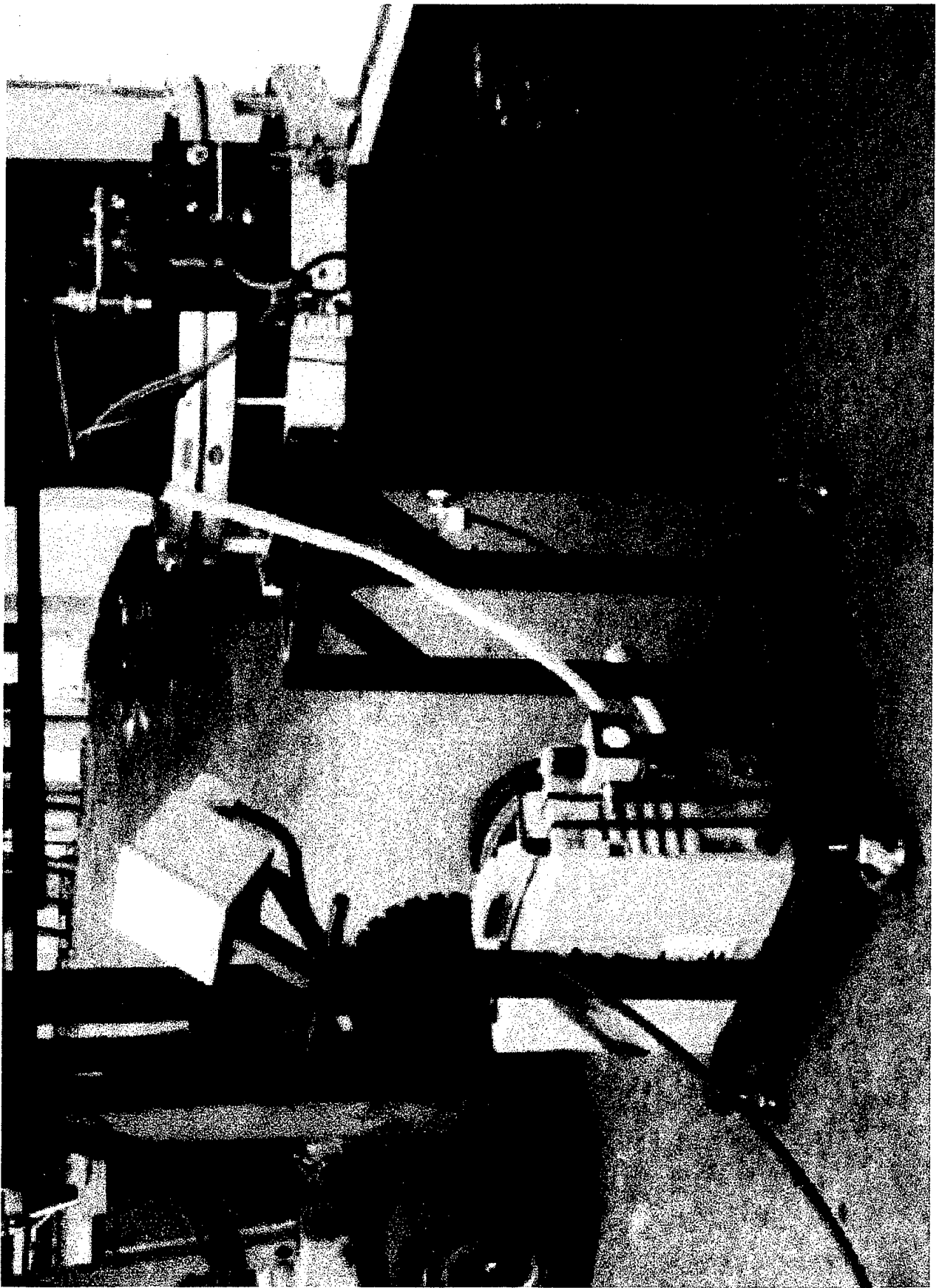

Figure 15 - Rapid Pipe Pile Cutter (RPPC) Model

Piercing time is also a function of bevel angle. The RPPC control system uses an adjustable timer relay to control the piercing dwell time (T1 of Figure 14) prior to activating the drive unit. The relay provides a time adjustment range of 0.5 seconds up to 999 minutes. The settings for this relay were derived empirically for piercing times vs. bevel angle during testing as shown in Section 7.2.2.

Though the model system requires the operator to make the appropriate settings on the drive unit and plasma arc unit for the particular circumstances, the system developed under Phase II will present the operator two switches, i.e. 1) pile diameter and 2) perpendicular or bevel cut. The appropriate settings for the plasma arc unit and drive unit will be done automatically. The model system will be used to generate the empirical data necessary to construct the appropriate look-up tables.

The only components of structural concern on the RPPC unit were the capacity of the four caster wheels designed to provide maneuverability of the unit. Appendix B contains the analysis of the wheel loading.

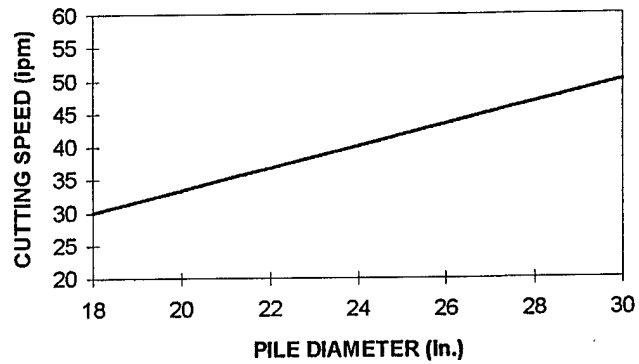

Figure 16 - Perpendicular Cutting Speed vs. Pile Diameter

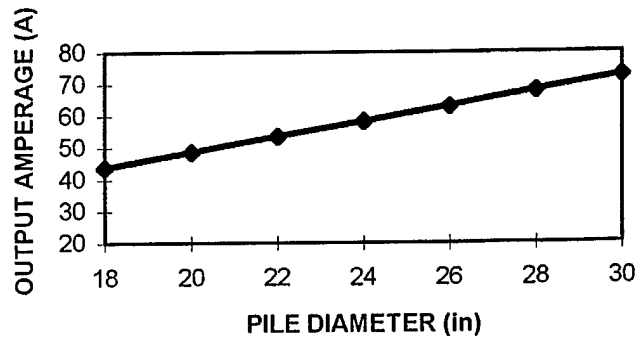

Figure 17 - Output Amperage vs. Pile Diameter

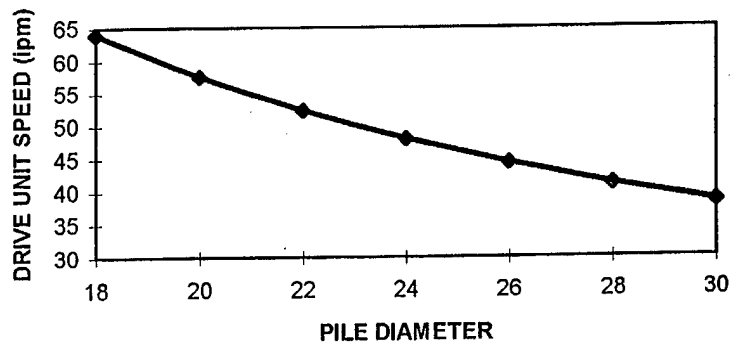

Figure 18 - Drive Unit Speed for 30° Bevel Cut vs. Pile Diameter

6.4.3 Prototype RPPC Safety Assessment

The RPPC system has been designed to allow the operator to perform pile cutting operations safely and efficiently. The drive unit/torch assembly is enclosed with a protective welding screen to provide protection from incidental exposure to the plasma arc. The shield provides a barrier from flame, arc, and sparks. The screen complies with OSHA 1910.252 (ii) Fire Curtains, (v) Shields and California Fire Marshall Codes. However, it is recommended that the operator wear a welders helmet equipped with number 6 or 7 lens shade to reduce exposure to the intense UV source and be informed and follow all safety precautions specified in the PCM-1000i Instruction Manual, P/N F-15-224-A December 1995. Existing U.S. Navy safety procedures for operating and maintaining similar apparatus should take precedent over the manufacturers' suggested precautions.

The drive unit/torch assembly translate around the pile on the ring rail track. The operator should avoid standing too close to the assembly as it travels around the track. It is recommended that the operator not place hands or other objects on or near the RPPC when in operation.

As with any electrical equipment, the operator should avoid electrical shock hazards by not opening any electrical enclosure. All electrical enclosures are high voltage shock hazards.

The RPPC model system is an experimental system and should be regarded as such. The purpose of the unit is to provide technical data and demonstrate the characteristics of operation.

6.4.4 Prototype HPG Design

The model HPG system shown in Figure 19 is a two axis hydraulic device. The hydraulic power unit is a Fenner two stage unit, P/N AB00189 capable of delivering pressures up to 3000 psi. The unit is capable of flow rates of 3.5 gpm in high range and 0.9 gpm in low range and has a self contained 1.75 gallon reservoir. It operates on 208/230 VAC power drawing 12.6 amps. The HPU was incorporated into the HPG model design to eliminate the need to perform modifications to fork lift trucks used for testing the device.

The output flow from the HPU is directed through 1/2 in., 3000 psi hydraulic lines to a Cross 4-way, open-center, adjustable relief hydraulic control valve. The hydraulic circuit is shown in Figure 20. The control valve allows operation of the tilt and gripping functions of the HPG. The hydraulic cylinders have a bore of 3-1/2 in. and a rod diameter of 1-1/4 in. The tilt cylinder has a stroke of 16 in. while dual 4-1/2 in. stroke cylinders are used to actuate the gripper jaws. Flow control valves are used on each port of the tilt cylinder to provide cylinder speed adjustment for the tilting function. These valves prevent movement of the pile too rapidly, limiting undesirable inertial effects. The grip portion of the system is fixed with an adjustable relief valve to limit gripping force to within design limits. A pressure gage is positioned on the output of the HPU and an additional gage is positioned in the gripping circuit. The HPU gage indicates the tilt cylinder pressure while the grip gage indicates grip cylinder pressure. All hydraulic components are rated at a minimum 2500 psi working pressure.

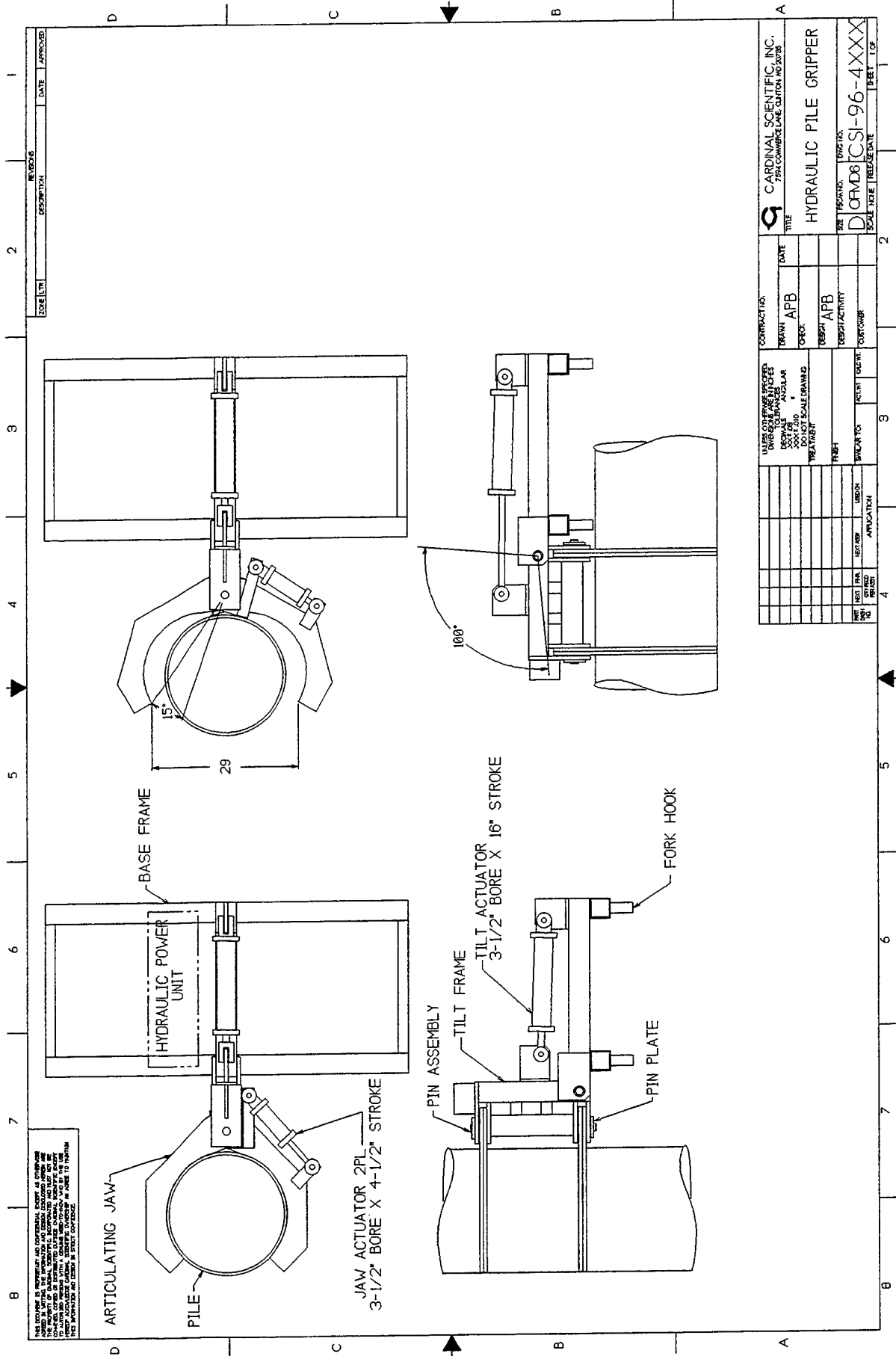

CONTRACTOR:		CARDINAL SCIENTIFIC, INC.	
DESIGNER:		7591 COMMERCE LANE, CLINTON, MO 64705	
DATE:			
PROJECT:		HYDRAULIC PILE GRIPPER	
SCALE:		AS SHOWN	
DRAWN BY:		D. ORMDEN	
CHECKED BY:		C. SI	
DATE:		96-4-XXX	
PROJECT NO.:		CSI-96-4-XXX	
SHEET NO.:		1 OF 1	

Figure 19 - Prototype HPG System Design
28

The HPG delivers a 100° of tilt range and a 30° grip range. The left control on the hydraulic control valve regulates flow to the tilt portion of the circuit. Pushing the control forward tilts the unit forward-- away from the operator, while pulling the lever rotates the unit towards the operator. The right control regulates flow to the grip portion of the circuit. Pushing the control closes the grip jaws while pulling the control opens the jaws.

The structure of the HPG is fabricated primarily from 4 in. x 4 in. x 1/4 in. wall A500 carbon steel while hydraulic cylinder interfaces and pivot points are fabricated from 3/4 in. 1018 cold drawn bar. Pivot pins are 1-1/2 in. diameter 1018 cold drawn bar. The four gripper jaws are fabricated from 3/4 in. low carbon hot rolled plate. Detailed design drawings are included in Appendix C. The model HPG system is shown in Figure 21.

6.4.5 Model HPG Analysis

Like the full scale HPG system, the model system must be able to perform pile handling operations without causing excessive permanent deformation to the pile. Many gripper jaw configurations were investigated. Several attempts at a serrated jaw design yielded high stress concentrations and local permanent deformation. It was determined that to minimize potential damage to the pile the gripping method must distribute the gripping force over a large circumferential region (see Figure 10). The benefits to the design are two-fold. First, the gripping force is highly distributed, limiting stress concentrations and, second, it restricts pile displacement to stiffer regions of the section as related to grip force vectors.

An analysis of the gripping force required to safely hold and manipulate a 24 in. x 10 ft. long pile was performed. All HPG calculations are contained in Appendix D. The pile weighs 1,263 lb. The required minimal gripping force is 2,339 lb. Each side of the gripper has two jaws providing a total contact area of 36.21 in² per set of jaws. The minimum gripping pressure is, therefore, 64.6 psi.

Finite Element Analysis (FEA) models of the pile were constructed to verify the gripping method and the effects the gripping force would have on the pile. The models simulated a 24 in. diameter pile and the imposition of the minimum required gripping pressure of 64.6 psi applied in opposed regions with the contact area equal to that of the gripper jaws. The maximum Von Mises stress in the pile was 748 psi while experiencing elastic deformation of 7.5×10^{-4} in. Applying a minimum safety factor of two, the design gripping pressure was established as 129 psi and the model reprocessed. The maximum Von Mises stress in the pile was increased to 1,495 psi while elastic deformation was only 1.5×10^{-3} in. Hot finished 1026 steel pile has yield strength of 75,000 psi. The results of the FEA pile modeling indicate that the design of the gripper jaws permit approximately 100 times the minimum theoretical gripping pressure before permanent pile deformation occurs. Figure 22 shows the finite element results for the pile analysis for the minimum gripping force and the theoretical design gripping pressure of 129 psi.

The design gripping pressure calculates to a total load of 4, 719 lb. per grip cylinder. Given an effective pressure area of approximately 9.6 in² the minimum grip circuit design pressure is 490 psi.

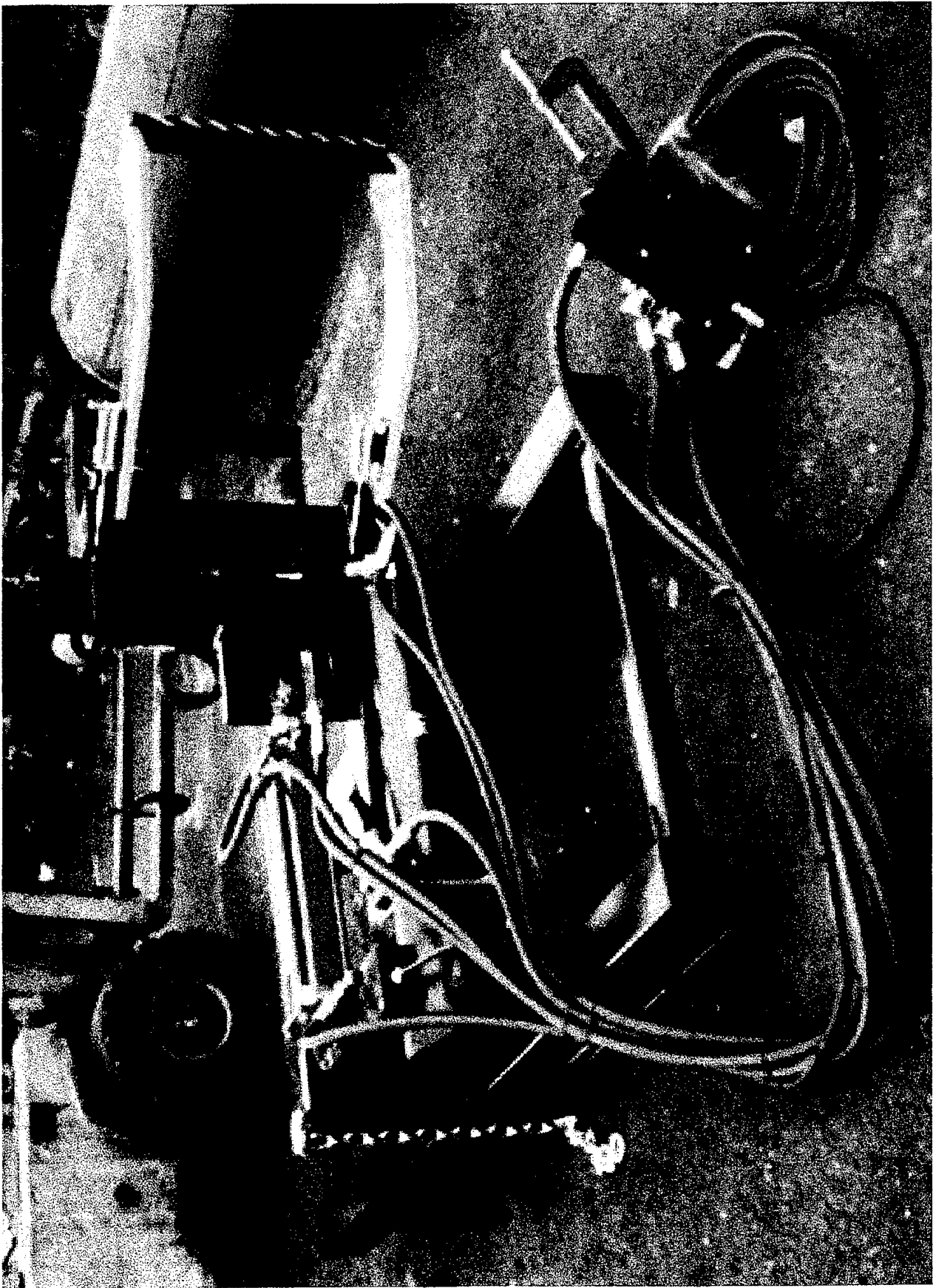
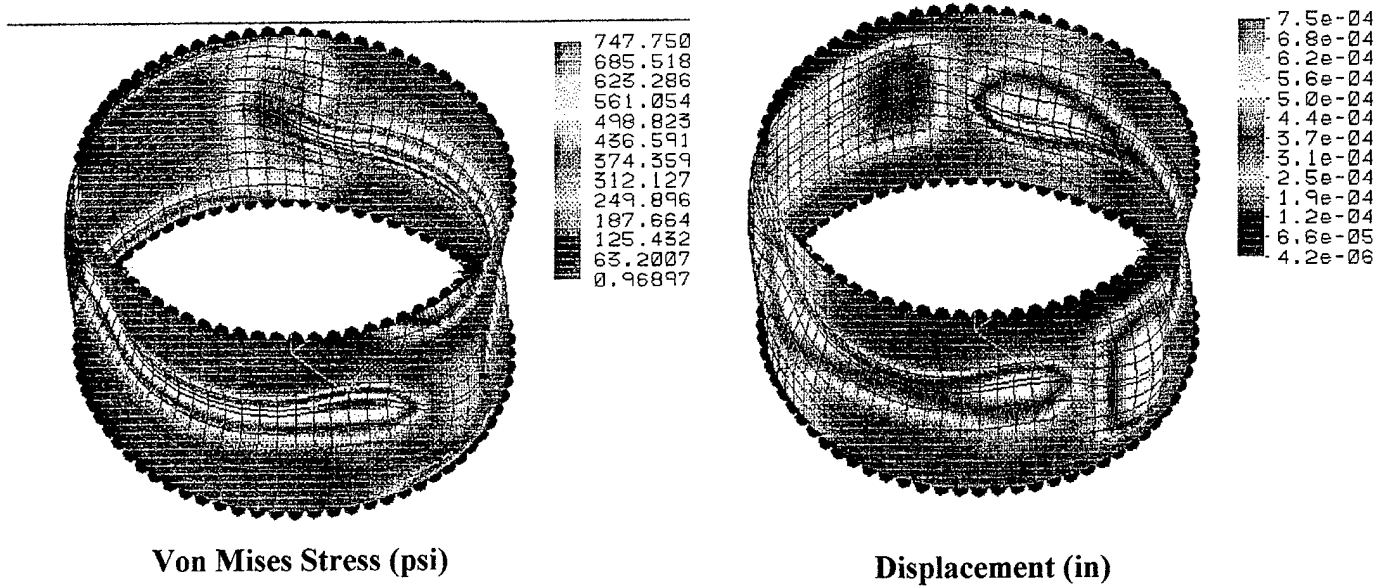
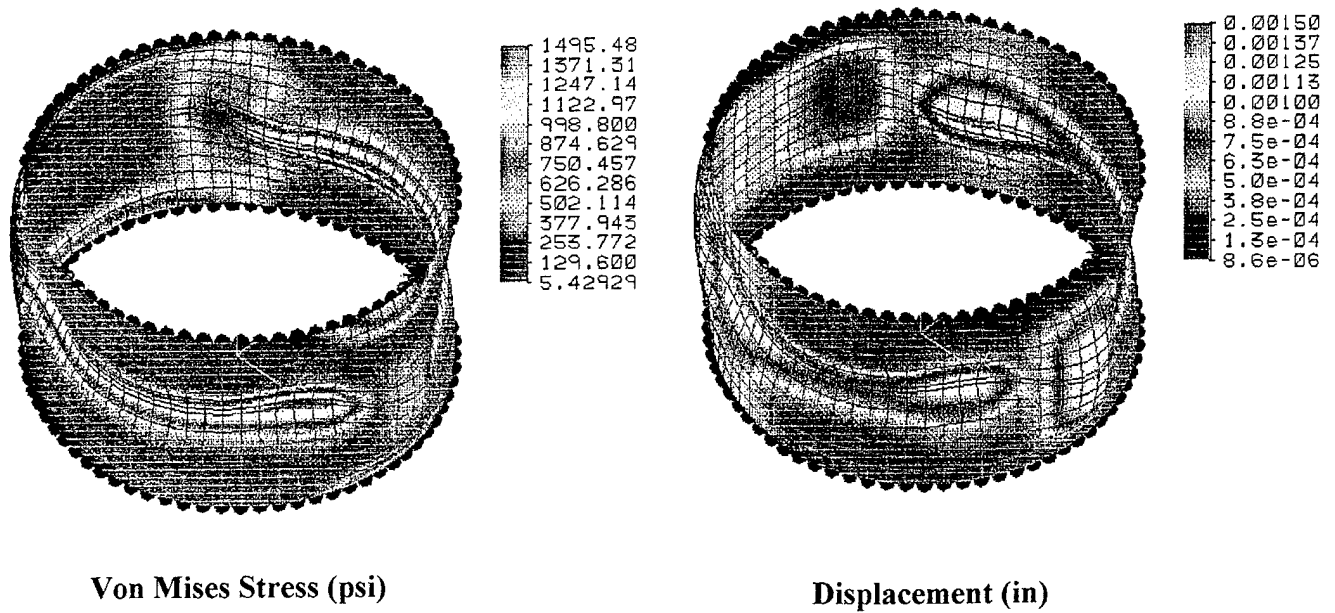

Figure 21 - Hydraulic Pile Gripper (HPG) Model



GRIP PRESSURE = 64.6 psi, MINIMUM



GRIP PRESSURE = 129 psi, DESIGN

Figure 23 - Pile Structural Reactions Due to Grip Pressure FEA Modeling Results

FEA models of the jaw were analyzed. The jaws were first modeled loaded only with the design cylinder force of 4,719 lb. acting on the pin location with the contact region of the jaw restrained. The resulting maximum Von Mises stress was 14,642 psi while the displacement was 0.013 in. The jaw was modeled with the weight of only the pile, 1,263 lb., acting in the z-direction. The maximum Von Mises stress was 241 psi while the displacement was 2.7×10^{-4} in. A combined loading scenario was performed modeling the gripping load and the weight of the cylinder. The results indicated a maximum Von Mises stress of 14,642 psi and a maximum displacement of 0.013 in. Figure 23 shows the FEA result of the jaw modeling for each of the loading scenarios.

Additional analysis was performed to determine if the pile, when in the horizontal position, would exert enough downward force on the upper jaws to overcome the gripping pressure. For the purposes of representing a worst-case analysis, it was assumed that pile contacts only the extreme edges of the jaws. The resulting load on the upper grip cylinder was 1,664 lb. or 2.84 times less than the design cylinder force.

An analysis of the tilt cylinder requirements was also performed. The worst case loading scenario is when the pile is in the horizontal position. The total load due to the weight of the pile and tilt portion of the HPG structure impose a total load of 8,564 lb. on the tilt cylinder which results in a minimum working pressure of 1,020 psi. Applying a minimum safety factor of two, the design pressure was established as 2,040 psi.

The pivot pin which permits rotation of the pile, experiences a worst-case design load of 18,726 lb. The 1-1/2 in. pin performs 7.36 times less than the yield strength of the material.

The bearing stress in the tilt arm plate worst-case design load was 22,837 psi which is 2.85 times less than the yield strength. The tilt arm plate has the smallest assembly weld area of the HPG and experiences the highest principal load per unit weld area of the HPG structure. The weld was analyzed assuming a worst case scenario and performs a minimum margin of safety of 2.51.

The results of the HPG analysis indicate that the model design is structurally robust and fully capable of safely manipulating a 10 ft. section of 24 in. x 0.5 in. wall steel pile.

6.4.6 Model HPG Safety Assessment

The HPG presents several potential hazards to the operator and other personnel. The hydraulic actuation of the device delivers high forces and locations are present where injury or dismemberment could occur. Personnel should not place hands or objects on or near the unit when in operation. Personnel should stand at a safe distance while pile manipulation is performed. Standard U.S. Navy safety precautions for hydraulic machinery and other similar types of equipment should be observed.

Von Mises Stress (psi)

Displacement (in)

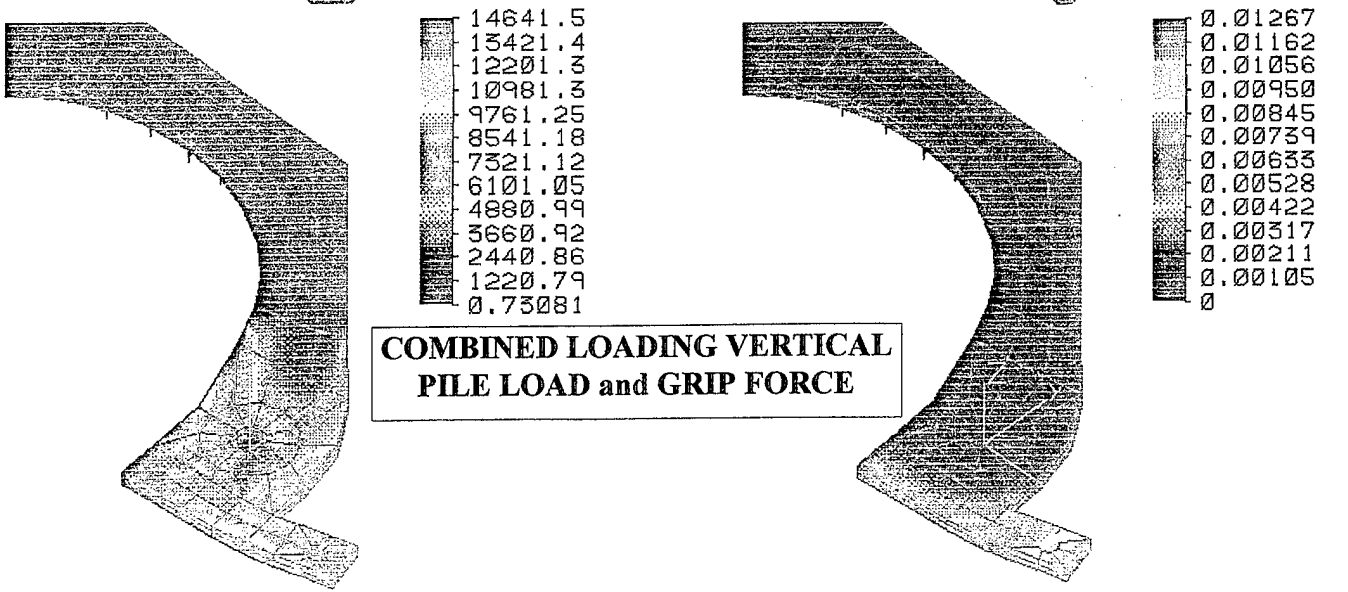
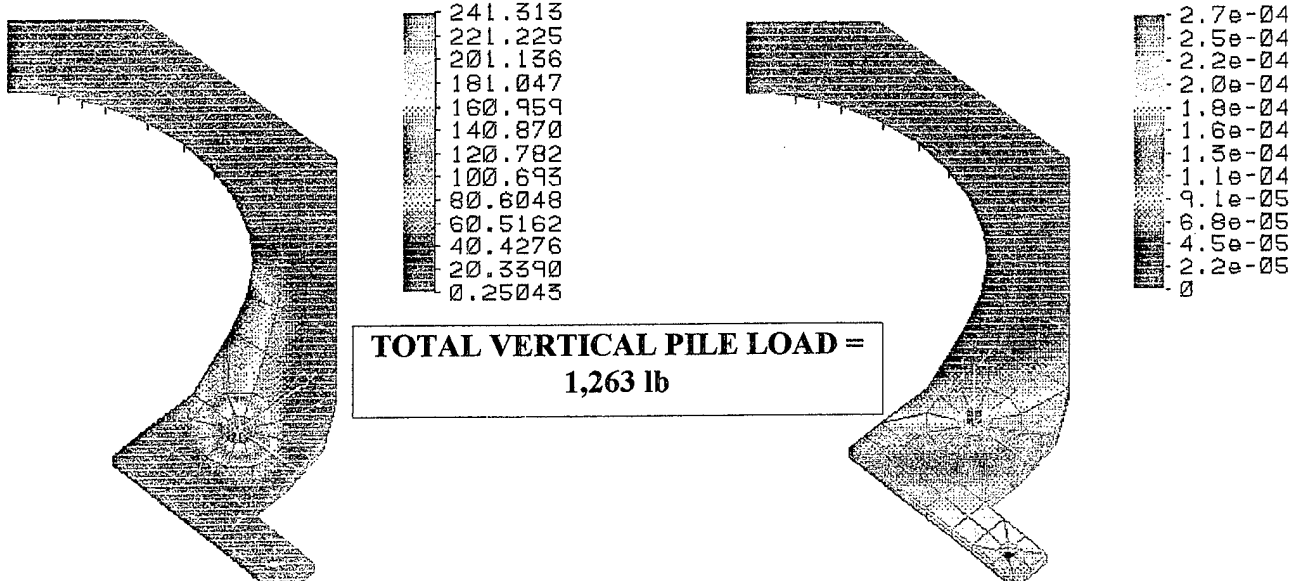
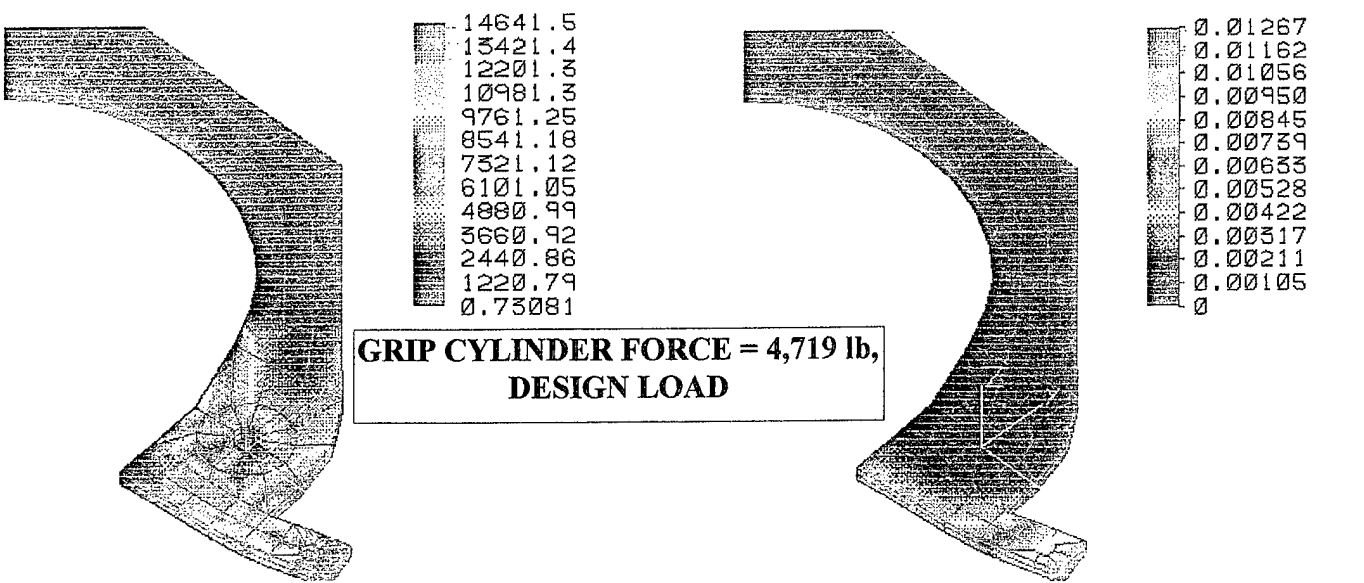

Figure 23 - Jaw Loading FEA Modeling Results

The handling of the forklift truck will be altered due the additional load and the inertial effects of the load. The forklift should be driven slowly while the HPG is installed. The gripper control should not be operated for reasons other than gripping or releasing a pile. The HPG model system is an experimental system and should be regarded as such. The purpose of the unit is to provide technical data and demonstrate the principals of operation.

7.0 Model Testing and Evaluation

Test plans were developed for the RPPC and HPG systems. The test plans were designed to provide reliable and repeatable empirical data on the performance of each system.

7.1 Test Plans

7.1.1 RPPC Test Plan

A. Maneuverability, Stability, and Self-Centering

1. Test the maneuverability in a 10 ft. x 10 ft. area
2. Test the stability of the unit.
3. Test the locking caster wheels ability to resist rolling on an inclined surface
4. Test that the self centering feature sets the torch at a consist distance from the pile when the clamshell is latched and casters unlocked. Repeat 10 times.

B. Control System Operation

1. Verify that all controls are operable
2. Test all limit switches in automatic and manual modes
3. Test manual control functions performance in manual mode
4. Verify that manual control functions are disabled in automatic mode
5. Test automatic control functions in automatic mode
6. Verify rapid reverse active on completion of forward travel
7. Verify that automatic control functions are disabled in manual mode
8. Test emergency stop control in automatic mode. Repeat 10 times.
9. Test torch ignition
10. Verify torch extinguishes in emergency stop. Repeat 10 times.
11. Verify compressed air delivery on torch ignition

C. Establish Piercing Dwell Times, Output Amperages, and Drive Unit Speed Settings

1. Determine average dwell time performing perpendicular pierce
2. Set timer T1 for dwell time determined
3. Verify dwell time is adequate by cycling the beginning of the automatic cutting mode 10 times.
4. Establish empirical output amperage for perpendicular cut to prevent automatic torch extinguishing.
5. Establish drive unit speed for perpendicular cut to prevent automatic torch extinguishing and ensure full cut penetration.
6. Repeat 1 through 5 for a 30 degree bevel cut.

D. Automatic Cutting

1. Set system to optimal settings established and perform 5 full automatic cutting cycles for perpendicular cuts.
2. Set system to optimal settings established and perform 5 full automatic cutting cycles for 30 degree bevel cuts.

7.1.2 HPG Test Plan

A. Control System Operation

1. Verify that all controls are operable
2. Verify settings of relief valves
3. Verify system hydraulic pressure
4. Cycle grip control through complete motion. Repeat 10 times.
5. Cycle tilt control through complete motion. Repeat 10 times

B. Gripping Force, Tilt Speed

1. Grip 10 ft. vertical pile with hydraulic grip pressure at theoretical design pressure.
2. Lift pile 1 in. Verify that no pile slippage occurs. Lower pile.
3. Fully open flow control valves on tilt cylinder
4. Lift pile 12 in. Cycle tilt control forward and backwards rapidly. Verify that no pile slippage occurs. Lower pile.
5. Reset the flow control valves on tilt cylinder
6. Lift the pile approximately 4 ft.
7. Tilt the pile to the horizontal position
8. Note grip cylinder hydraulic pressure
9. Verify no pile slippage occurs
10. Return the pile to vertical position
11. Note tilt cylinder pressure

C. Maneuverability, Stability, and Self-Centering

1. Test the maneuverability of in a 30 ft. x 30 ft. area with pile in horizontal position
2. Test the stability of the unit under acceleration.
3. Test the stability of the unit under braking
4. Test the stability of the unit with pile in vertical position performing slow turns
5. Test that the self centering feature provides proper jaw engagement. Repeat 10 times.

D. Combined Testing

1. Perform operational test
2. Position RPPC around pile
3. Position HPG to grip pile

4. Perform RPPC automatic cutting cycle
5. Remove RPPC from cut pile
6. Manipulate cut pile with HPG

7.2 Test Results

7.2.1 RPPC Test Results

7.2.1.A. Maneuverability, Stability, and Self-Centering

The RPPC model was easily maneuvered in a 10 ft. x 10 ft area. The uni-directional caster wheels permitted the unit to maneuvered with its own length; approximately 6 ft. The unit was determined to be stable during all maneuvers. The plasma unit adequately counter balances the overhung clamshell/drive unit throughout the complete cutting cycle. Locking the rear caster wheels prevented the unit from rolling on inclines of approximately 10 degrees.

The centering studs were adjusted to maintain the torch a distance of 1/8 in. to 3/16 in. from the pile surface. The RPPC was engaged and disengaged from the pile in excess of 30 times and maintained the torch stand-off distance during dry runs and while performing cutting operations.

7.2.1.B. Control System Operation

All control systems and devices were verified for proper operation in manual and automatic modes. Manual controls permitted jogging the drive unit in the forward and reverse directions up to the respective limit switch locations. The automatic cycle provided initial piercing dwell, speed controlled forward motion, arc extinguishing, rapid reverse to home position. Forward speed was verified to be controlled by the speed control potentiometer on the drive unit. The emergency stop function was verified during both forward and reverse directions. The emergency stop activation properly extinguished the arc and halted drive unit motion in the forward cutting cycle. Emergency stop activation during the reverse portion of the cycle halted drive unit motion. The operation of the manual and automatic controls were verified cycling through each function a minimum of ten times. The model control panel and drive unit are shown in Figure 24. The weld screen directed sparks and slag away from the operator and provided protection from the UV source.

7.2.1.C. Establish Piercing Dwell Times, Output Amperages, and Drive Unit Speed Settings

The RPPC unit was designed to cut 0.5 in. thick pile. All testing was performed using 0.375 in. thick pile due to the unavailability of 0.5 in. material. Equation (1) was used to determine the torch angle of 41.4° to simulate the 0.5 in wall thickness for perpendicular cuts and 49.5° to simulate 30° bevel cuts (see Figure 25). Piercing dwell times were determined by activating the torch and measuring the time required for full penetration to occur. The piercing time was determined to be approximately 4.0 seconds for both perpendicular and bevel cuts.

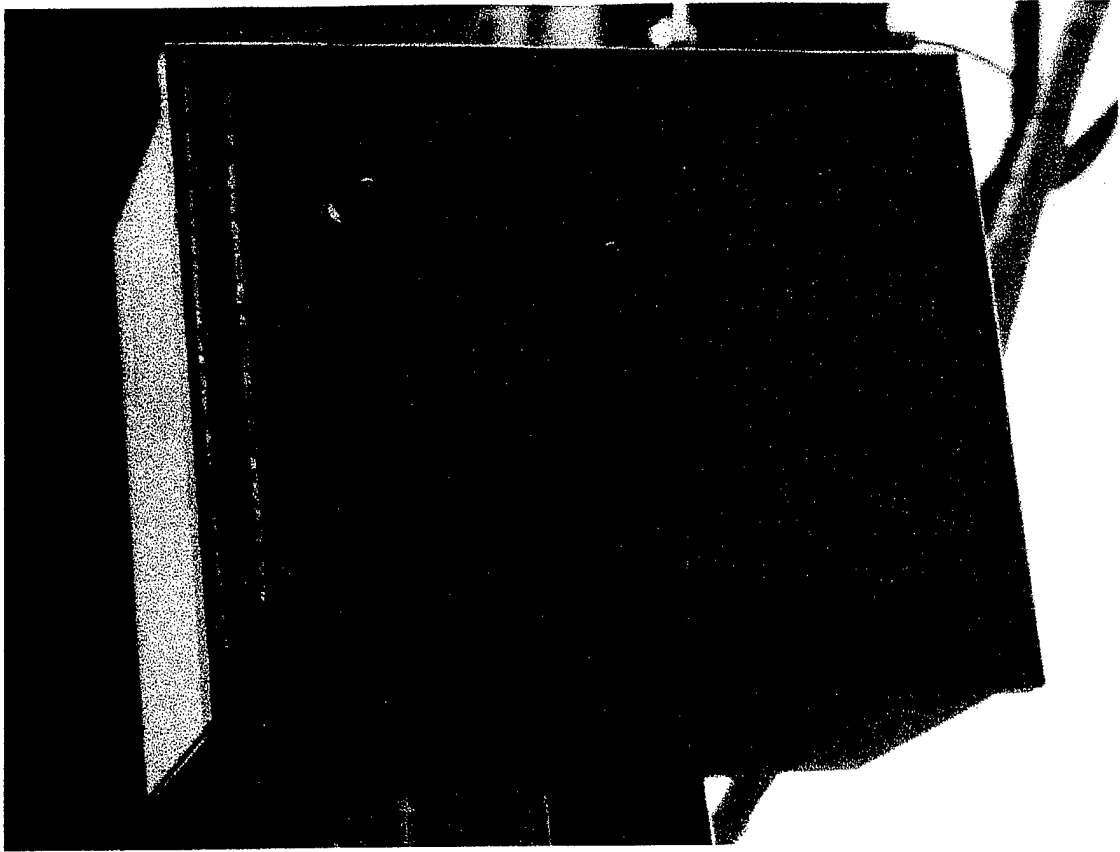

RPPC Operator Control Box

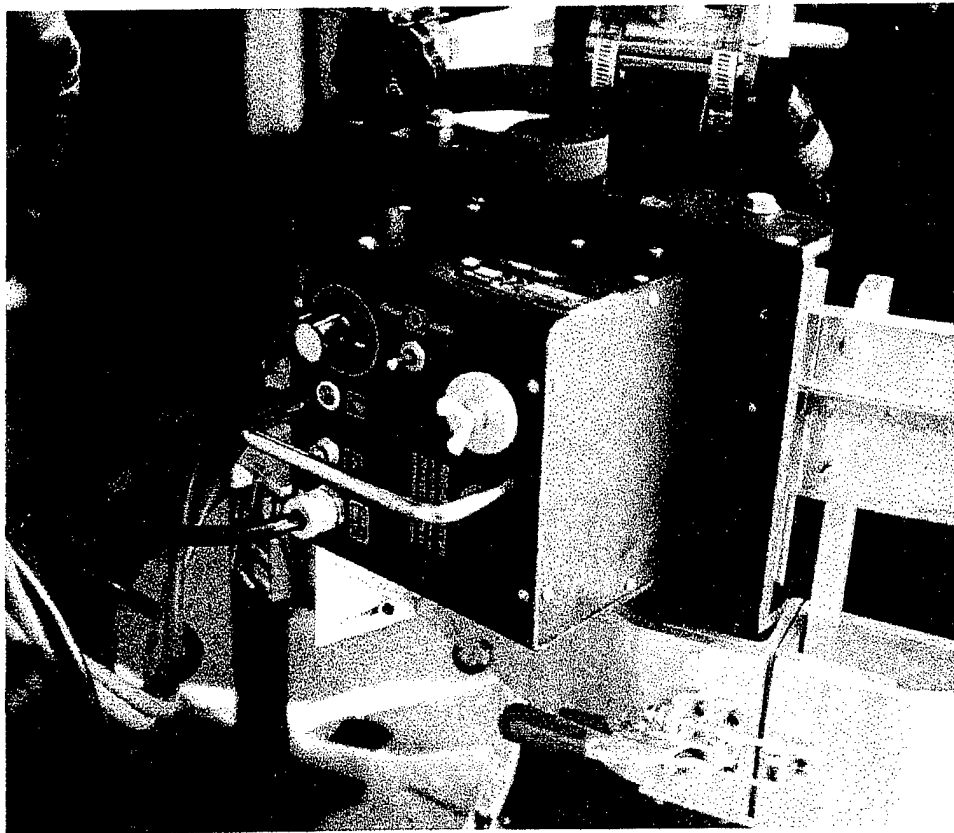

RPPC Automatic Drive Unit

Figure 24 - RPPC Operator Control Box and Automatic Drive Unit

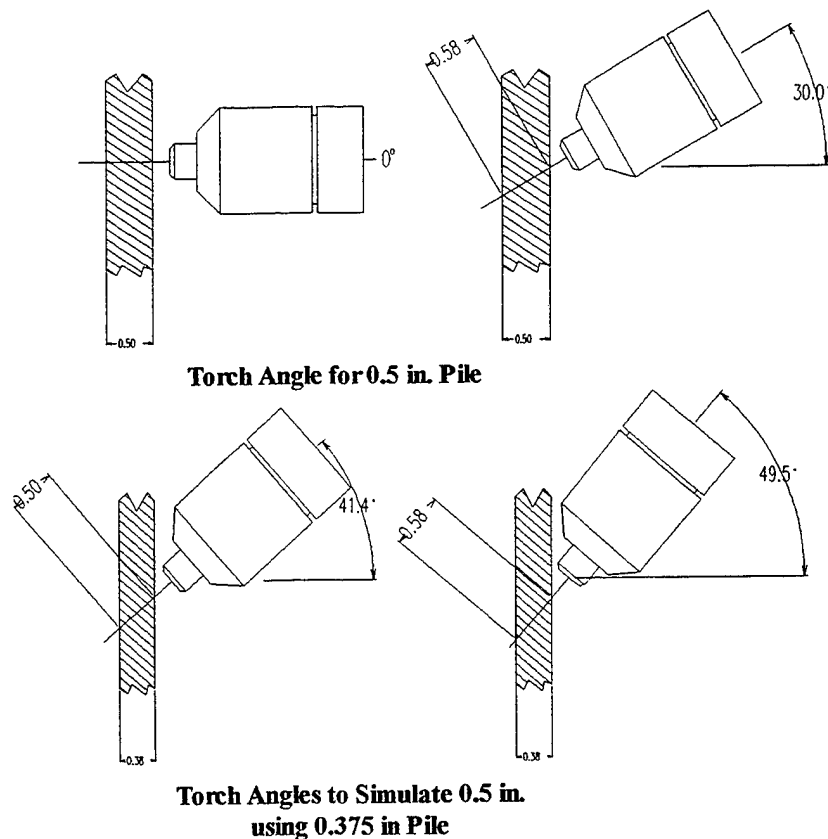

Figure 25 - Torch Angles used for Testing Perpendicular and Bevel Cuts

This time was programmed into the timer relay, T1. This setting provided ample penetration time while not being excessive to automatically extinguish the arc. The dwell time was verified by starting the automatic cutting cycle 10 times ensuring full penetration prior to activating forward motion. All testing was performed with T1 set a 4.0 seconds.

Upon activation of the reversing limit switch, timer relay, T2, allows the drive unit motor to come to a complete stop prior to reversing the polarity (and direction); preventing continued motion in the forward direction while under reverse polarity. The low gear train inertia allowed T2 to be set at 0.5 seconds. This setting provided ample time to dissipate the forward inertia of the drive unit at maximum speed and was used for all testing.

As shown in section 6.4.2 (Figure 16), the maximum theoretical cutting speed for the 24 in. diameter pile is 40 ipm based on the manufacturers data of 60 ipm relative to the 36 in. ring rail diameter. The drive unit velocity was measured to verify the manufacturers claim. The actual maximum drive unit speed was 63.4 ipm which equates to a maximum cutting speed of 42.3 ipm for the 24 in. pile.

According to the manufacturers data, the PCM1000i should deliver cutting speeds of 55 ipm on 0.5 in. carbon steel. Therefore, perpendicular cutting speed performance was theoretically limited by drive unit speed. The theoretical output amperage to prevent automatic arc

extinguishing was 58 A at a cutting speed of 40 ipm. However, all attempts to operate the drive unit at 40 ipm with increasing output amperages resulted in insufficient penetration. The PCM1000i was set at the maximum output amperage of 80 A while decreases in drive unit speed were continued until full penetration could be maintained throughout the cutting cycle. The maximum cutting speed for the simulated perpendicular cut was 21.9 ipm at 80 A. This is approximately 2.5 times less than the manufacturers claim for 0.5 in. steel. To establish if the torch angle had any effect on cutting speed, tests were performed on the 0.375 in. thick pile with the torch angle set to zero degrees. The manufacturers data indicates cutting speeds of 89 ipm for an 80 A setting. The maximum sustainable cutting speed was 34.3 ipm. or 2.6 times less than the manufacturers claim. The effect of the 41.4° torch angle to simulate 0.5 in. thickness was, therefore, negligible. Given these results, all testing was performed with the PCM1000i set at 80 A.

Tests were performed to determine the cutting speed and output amperage for performing 30° bevel cuts. The torch angle was set to 49.5° to simulate the required 0.58 thickness. Several attempts were made to sustain penetration throughout the cutting cycle. However, after a few inches of full penetration, the plasma torch began gouging the material without complete penetration. Further testing revealed that any torch angle setting greater than 45° would not sustain penetration. Given the proportional results of the testing on the 0.375 in. thickness, bevel cut testing was performed at 30° at 0.375 in. thickness.

Table 1 shows settings for the RPPC model system for the type of cut performed.

Table 1. Model RPPC System Settings

SETTING	0.375 0°	0.375 30°	0.5 0°	0.5 30°
Cut Reference Type	Perpendicular	Bevel	Perpendicular	Bevel
Piercing Relay, T1	4 sec.	4 sec.	4 sec.	4 sec.
Reverse Relay, T2	0.5 sec	0.5 sec	0.5 sec	0.5 sec
Output Amperage	80 A	80 A	80 A	80 A
Drive Unit Setting	80	64	50	39*
Cutting Speed	34.3 ipm	29.6 ipm	21.9 ipm	17.4 ipm*

* Calculated based on 0.375 in cutting performance.

7.2.1.D. Automatic Cutting

The RPPC system was configured to the settings as shown in Table 1 for 0.5 in. perpendicular cutting. Five fully automatic cycles were performed. Continuous cut penetration was achieved during each cycle. Each cutting cycle was timed at 3 minutes 44 seconds or 21.9 ipm for a drive unit setting of 50 and output amperage set at 80 A. The return cycle, operating at maximum drive unit speed, is independent of cutting speed and was constant at 1 minute 47 seconds. The total automatic cycle was 5 minutes 31 seconds. Additionally, placement of the RPPC around the pile and attaching the magnetic ground lug took approximately 15 seconds.

Removal from the pile was accomplished in 5 seconds. This results in an average process speed for the perpendicular cut of 75.4 in. per 5 minutes 51 seconds or 12.9 ipm.

Three fully automatic tests were performed on the 0.375 in. pile with the torch angle set to 0° using the settings shown in Table 1. Full penetration was achieved during the 2 minutes 20 seconds cutting cycles. The constant return cycle of 1 minute 47 seconds yielded total automatic cycle times of 4 minutes 7 seconds.

Since accurate simulation of the 30° bevel cut could not be accomplished, five test were performed with the torch angle set to 30° on the 0.375 in. thickness for extrapolation purposes. With the output amperage at 80 A and the drive unit set to 64, the total cutting cycle times were 2 minutes 55 seconds or 29.6 ipm.

It is estimated that the automatic cutting cycle for the 30° bevel cut on 0.5 in material could be accomplished in 4 minutes 20 seconds. Given the constant return cycle time of 1 minute 47 seconds and the placement and removal times of 20 seconds, the total process time is estimated to be 6 minutes 27 seconds or 11.7 ipm. Table 2 shows the results of the automatic pile cutting testing.

Each test resulted in excellent cut quality with minimum scalloping and clean slag removal. Figure 26(a) shows a typical cut before slag removal and after slag removal in Figure 26 (b). The cuts were even and square and would not require additional finishing prior to pile splicing operations.

Table 2. Model RPPC Automatic Cutting Cycle Performance

SETTING	0.375 0°	0.375 30°	0.5 0°	0.5 30°
Cut Reference Type	Perpendicular	Bevel	Perpendicular	Bevel
Number of Tests	3	5	5	-
Output Amperage	80 A	80 A	80 A	80 A
Cutting Speed	34.3 ipm	29.6 ipm	21.9 ipm	17.4 ipm*
Cutting Cycle Time	02:20	02:55	03:44	04:20*
Reverse Cycle Time	01:47	01:47	01:47	01:47
RPPC Placement	00:15	00:15	00:15	00:15
RPPC Removal	00:05	00:05	00:05	00:05
Total RPPC Process Time	04:27	05:02	05:51	06:27*
Total RPPC Process Rate	16.9 ipm	15.0 ipm	12.9 ipm	11.7 ipm*

* Calculated based on 0.375 in cutting performance.

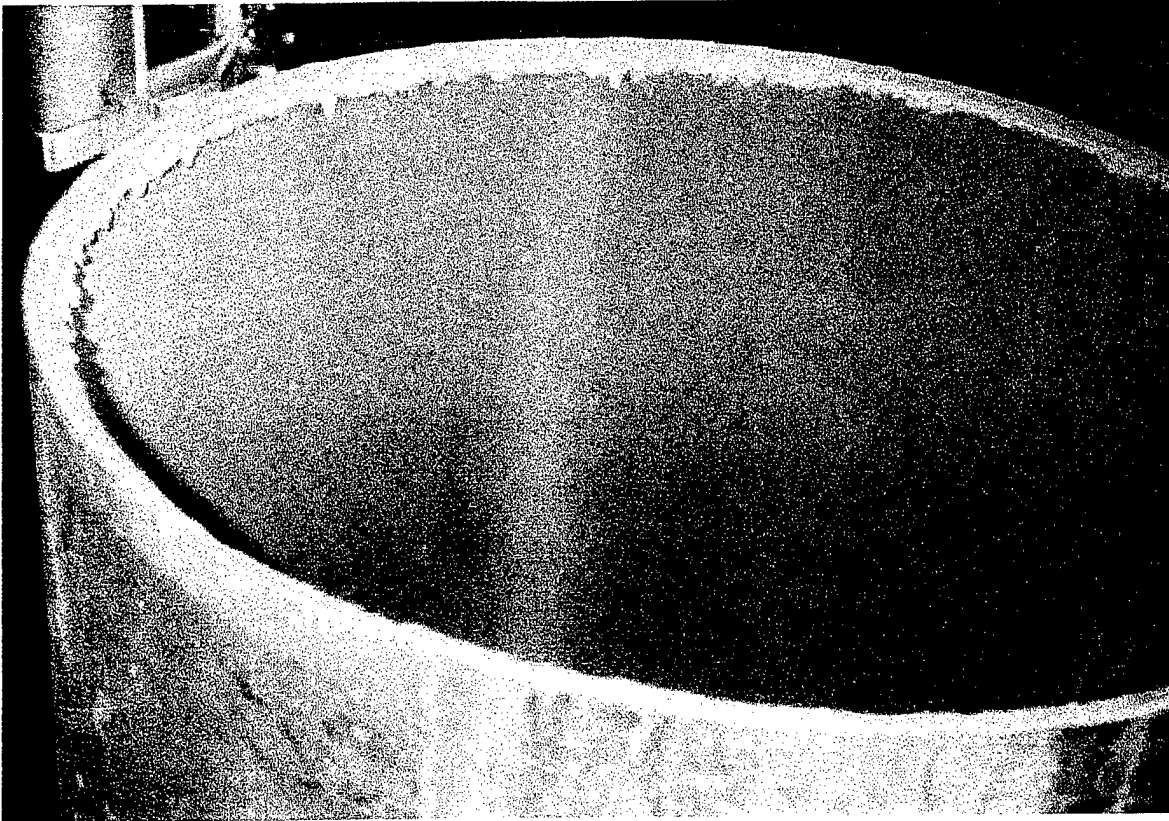

Before Slag Removal

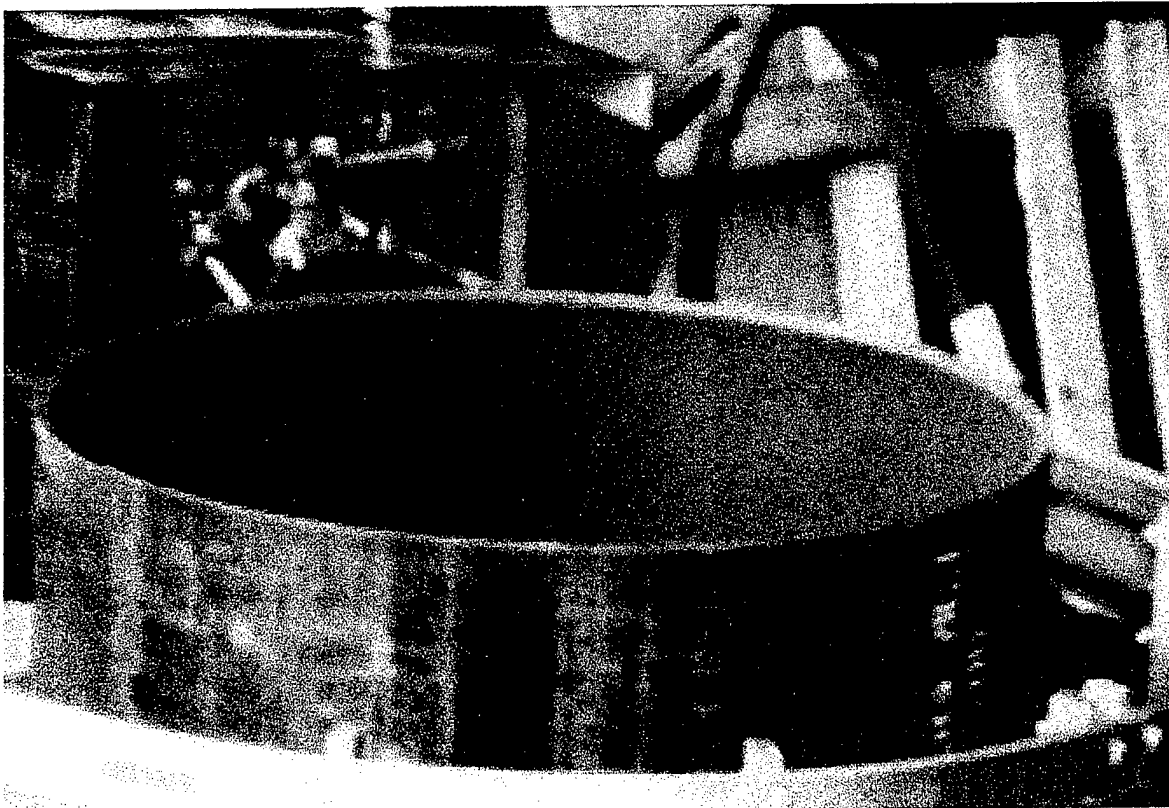

After Slag Removal with Slag Hammer

Figure 26- PCM1000i Cut Quality

7.2.2 HPG Test Results

7.2.2.A. Control System Operation

The HPG was reviewed prior to applying power to ensure that all hydraulic line routing corresponded to the system design schematic. Upon power-up, the adjustable pressure relief integrated into the four way control valve was set at the design tilt cylinder pressure of 2,040 psi. The grip pressure adjustable relief valve was set at the design pressure of 490 psi. The tilt function was cycled a minimum of ten cycles to verify adequate hydraulic line service loops. The Tilt cylinder pressure was checked at the extremes of the stroke. Similarly, the grip cylinder motion was cycled to verify hydraulic line routing and cylinder pressure at each end of the stroke. The four way control valve mounted to the forklift is shown in Figure 27.

7.2.2.B. Gripping Force, Tilt Speed

The theoretical grip pressure was tested to verify that no pile slippage occurred throughout the full range of motion of the HPG. Additionally, observations for pile deformation were performed throughout the cycle. An 11 ft. pile was gripped and raised several inches with no pile slippage. The pile was then raised several additional inches and the tilt control was cycled rapidly with no pile slippage. The pile was then raised several feet and tilted forward approximately 30° while the tilt cylinder forward flow control valve was set to deliver a forward tilt speed of approximately 6° per second. The pile was then lowered to the horizontal position. Similarly, the reverse tilt speed was to approximately the same setting using the tilt cylinder reverse flow control valve. The speed settings for the tilt function controlled the inertial effects imposed on the forklift truck due to sudden activation/deactivation of the tilt motion.

No adjustment to the design pressures for the grip or tilt circuits were required. No pile slippage occurred during any pile manipulation testing. Additionally, no permanent pile deformation was observed and no visible deformation was apparent while under grip pressure.

7.2.2.C. Maneuverability, Stability, and Self-Centering

The HPG was designed to “float” on the forks of the forklift truck to provide a self-centering characteristic. A safety chain connects between the HPG and the fork structure. The length of the chain was set to limit the outward movement of the HPG to approximately 3 inches from the end of the forks. This length provide the necessary movement for the unit to self-center, while retaining the unit on the forks. The function of the self-centering design was tested in excess of 20 times with gripper jaw angles up to approximately 10° and all tests resulted in uniform contact between the pile and jaws. The HPG was able to be positioned around and grip a pile in under 1 minute.

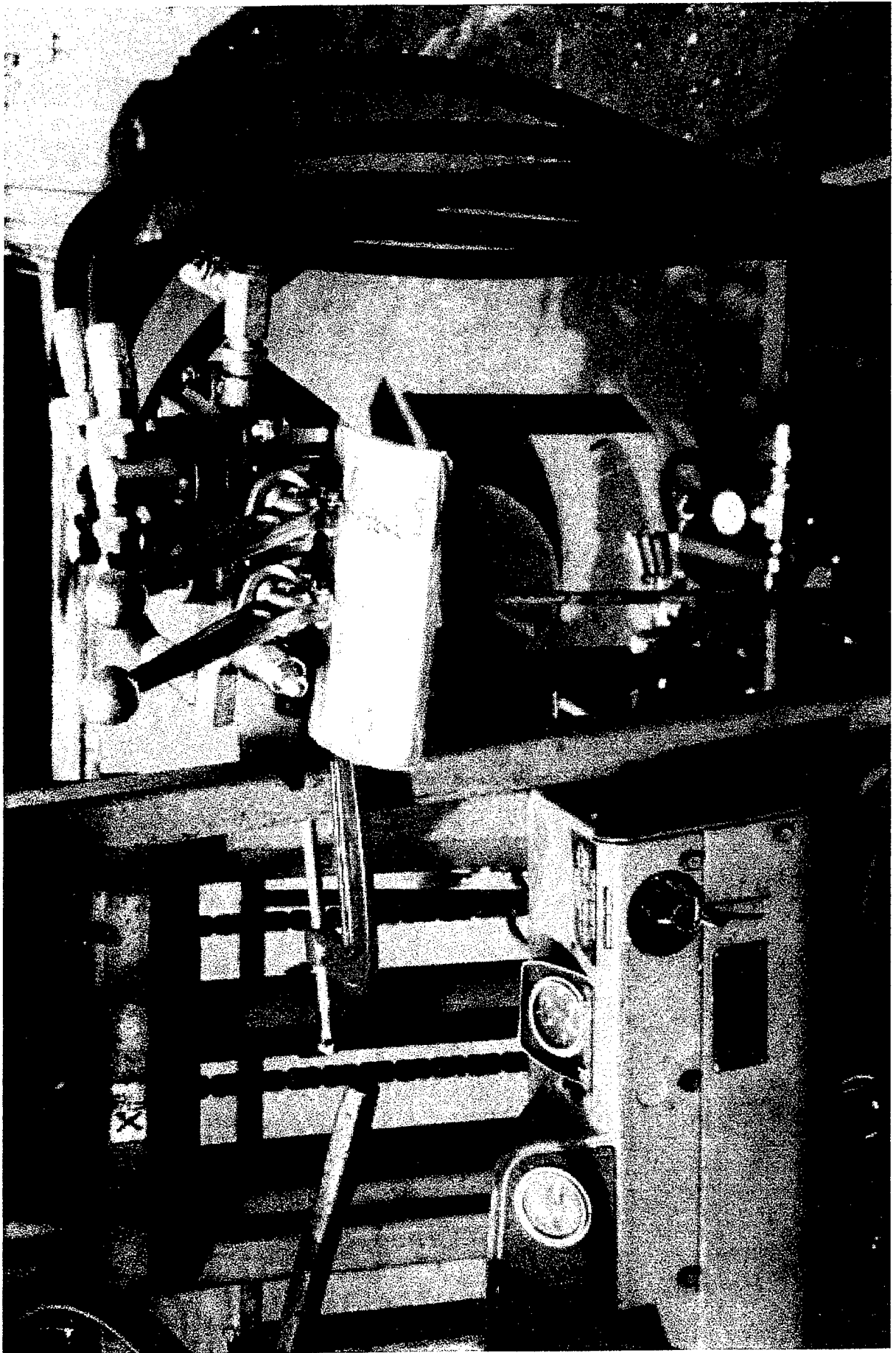

Figure 27 - Four-Way Hydraulic Control Valve

The maneuverability of the forklift was tested with the pile in the horizontal and vertical positions. The unit was easily maneuvered in a 30 ft. x 30 ft. area. The forklift remained stable and controllable under acceleration, braking and turning while the pile was vertical as well as horizontal.

7.2.2.D. Combined Testing

During the combined testing, the RPPC and HPG were used together to support a 24" diameter steel pile while performing a cutoff operation. Figure 28 shows the typical relationship of the RPPC and forklift mounted HPG during combined testing. The combined test entailed, the RPPC being wheeled near the vertical pile to be cut and the clamshell opened. The RPPC was then pushed against the pile where the centering studs contacted the pile and the clamshell closed and latched. The magnetic ground lug was placed on the lower region of the pile. The forklift then positioned the HPG approximately 2 ft. above the cut zone and gripped the pile. The RPPC was then energized and upon activation of the START switch performed the automatic cutting operation. At the end of the cutting cycle, the plasma torch extinguished and returned to the home position. The clamshell was open and the RPPC cleared from the pile. The forklift then lifted the pile and backed clear of the stationary pile and lowered the cut section. The cut section was rotated horizontally and lowered to the deck and released. The forklift then backed away from the cut section. Combined testing times ranged from 6 to 8 minutes per pile. Figures 29 (a) through (f) shows sequence of operation. Appendix E contains the instructions for operating the RPPC and HPG prototype models.

8.0 Conclusions

The successful completion of Phase I has resulted in a thoroughly researched, safe technology for rapidly cutting and handling the steel pilings for the deployment of the ELCAS(M) system.

Though the system developed under this effort were for concept validation, the design is readily scaleable for full-scale operation. The testing resulted in predictable, repeatable performance. The cutting speed performance of the RPPC was slower than anticipated due to the manufacturers overstated performance claims. However, overall process rates for the model RPPC were at least two times faster than the current manual cutting process currently in use and can be performed without the use of the crane. Significant increases in the process rate can be achieved by increasing the reverse cycle speed of the drive unit. The 1 minute 47 seconds cycle can be reduced to approximately 54 seconds by increasing the maximum drive unit speed by a factor of two. This would result in a 15 percent increase in the process rate with the same plasma cutter performance.

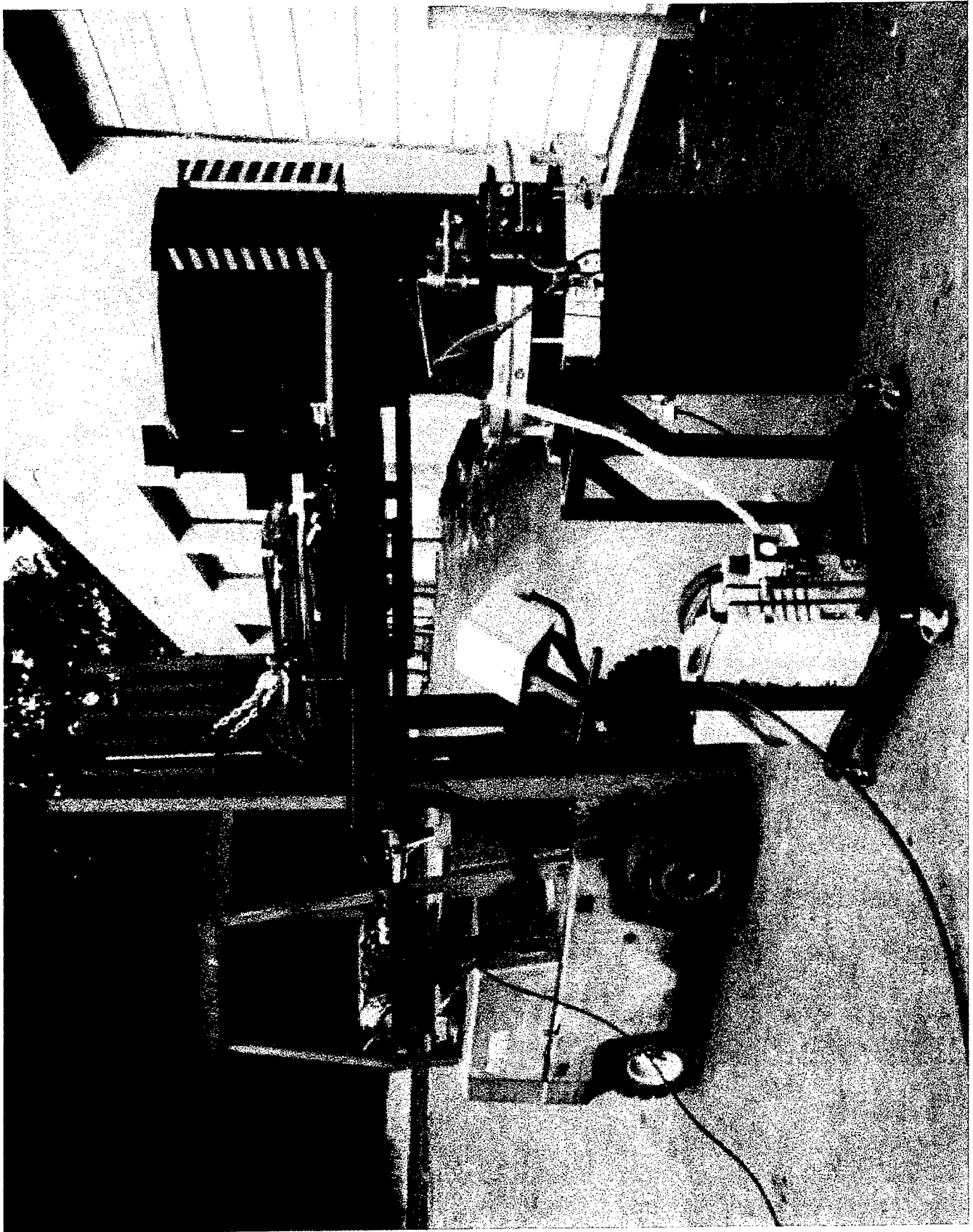
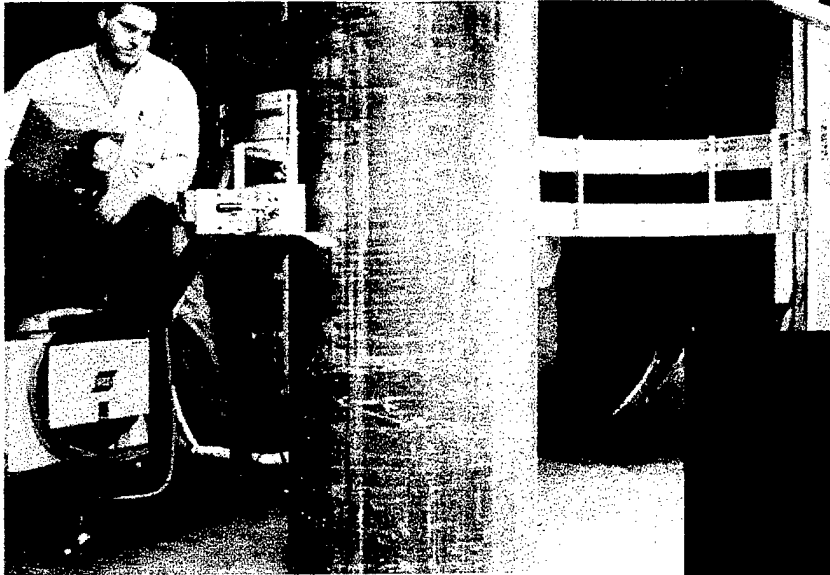
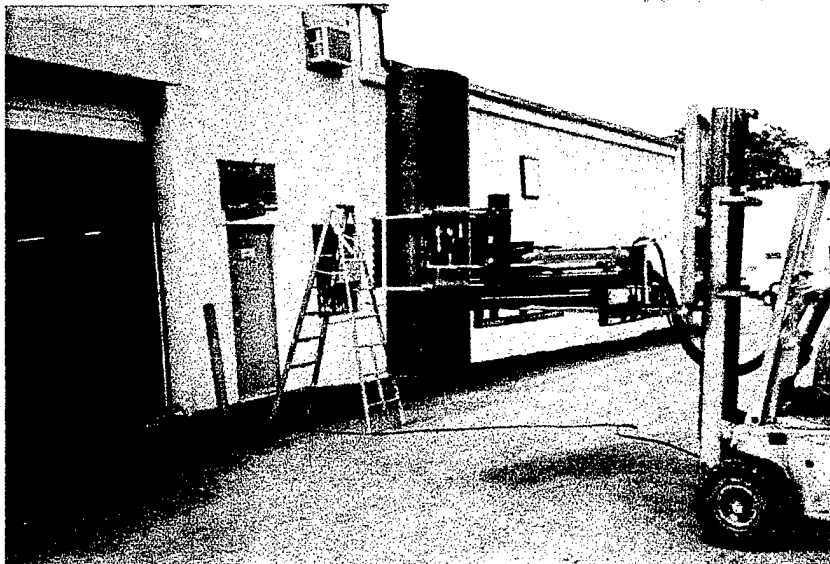
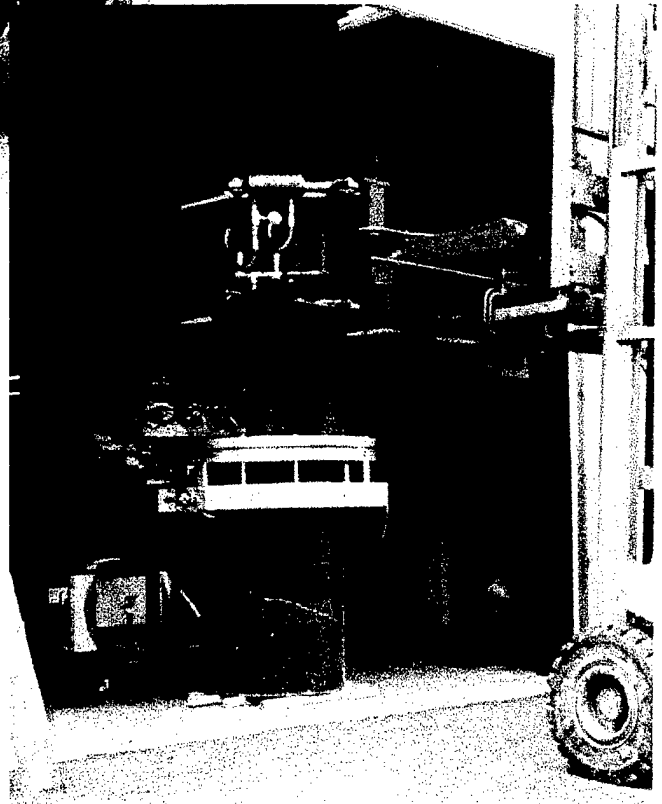

Figure 28 - RPPC and HPG Combined Operations



(a) - RPPC Positioned Around Pile

(b) - HPG Grips Pile and RPPC Performs Automatic Cutting Cycle



(c) - HPG Removes Cut Section of Pile

Figure 29- Combined RPPC and HPG Pile Cutting Operation

(d) - HPG Rotates Cut Pile

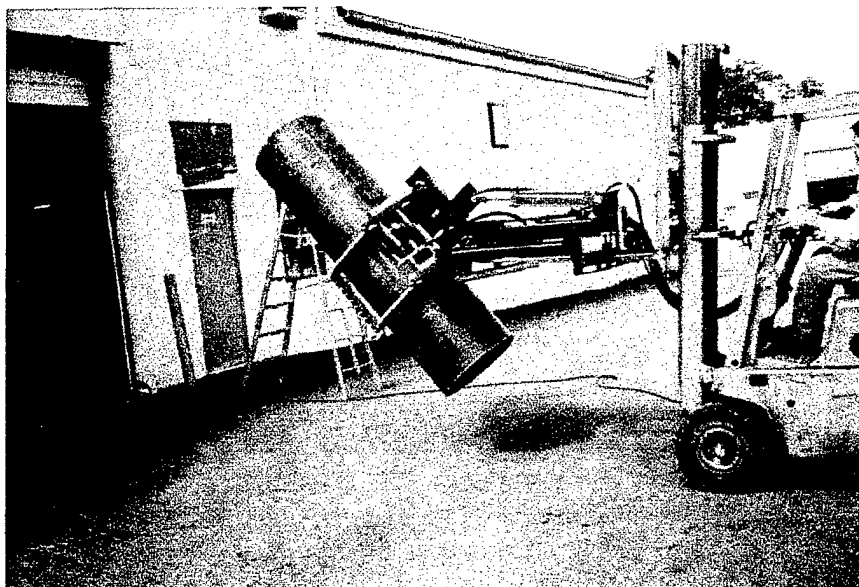

(e) - Pile Rotated Horizontal and Lowered for Transit

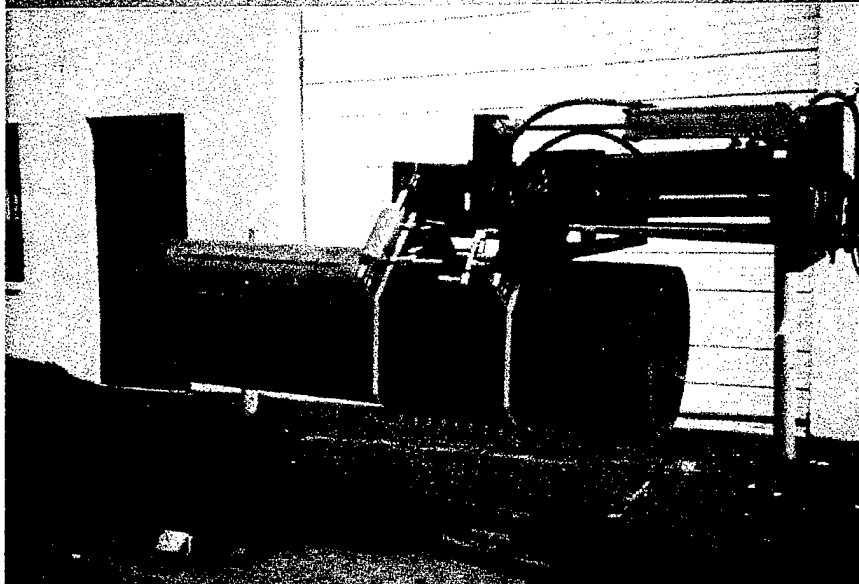

(f) - At Destination, HPG Lowers and Releases Cut Pile



Figure 29- Combined RPPC and HPG Pile Cutting Operation (cont.)

Several additional features can be incorporated to make the RPPC and HPG more versatile for the deployment of the ELCAS(M) such as: providing height adjustment on the RPPC to allow the unit to be used for sub-deck pile cutting, adding 3-axis centering capability for the RPPC to compensate for piles driven at small angles from vertical, and allowing the RPPC to be rotated for cutting piles in a horizontal orientation for on-shore pile splicing operations. Adaptation for pile welding could also be integrated.

The conclusion of the Phase I effort has yielded fully designed, analyzed, documented and tested model systems developed within the bounds of the U.S. Navy's requirements, desires, logistics and safety parameters. Developed, full scale systems will minimize the use of the crane for the majority of the pile cutting process. The analytical estimates of the principals of operation have been verified through model fabrication, assembly and testing.

9.0 Recommendations

The results of the Phase I effort have established an excellent foundation for a smooth transition into Phase II. Under Phase II the model system will be thoroughly reviewed and tested further, while shortcomings will be addressed and appropriate modifications will be incorporated into a production model system design. The system will be evaluated under actual service conditions to reveal operational performance limits. The final system design will be fully documented and prepared for immediate Phase III acquisition. The results of this effort justify further development under Phase II and it is recommended that valuable results achieved under this effort be immediately pursued.

References

1. Baumeister, T. and Lionel S. Marks: *Thermal Cutting of Metals*, Standard Handbook for Mechanical Engineers, 7th edition, p.13-51.
2. Baumeister, T. and Lionel S. Marks: *Thermal Cutting of Metals*, Standard Handbook for Mechanical Engineers, 7th edition, p.13-53.
3. Hecht, Jeff: *The Laser Handbook*, 2nd edition, 1992.
4. Waynant, Ronald and Marwood Ediger: *Electro-optics Handbook*, 1st Edition, 1994.
5. Naval Construction Battalion Center: *Self Study Workbook Volume 1 of 2 for Elevated Causeway System (Modular) Specialist Course*, CIK-062-0102, Aug. 1995.

Appendix A - Prototype RPPC Detailed Design Drawings

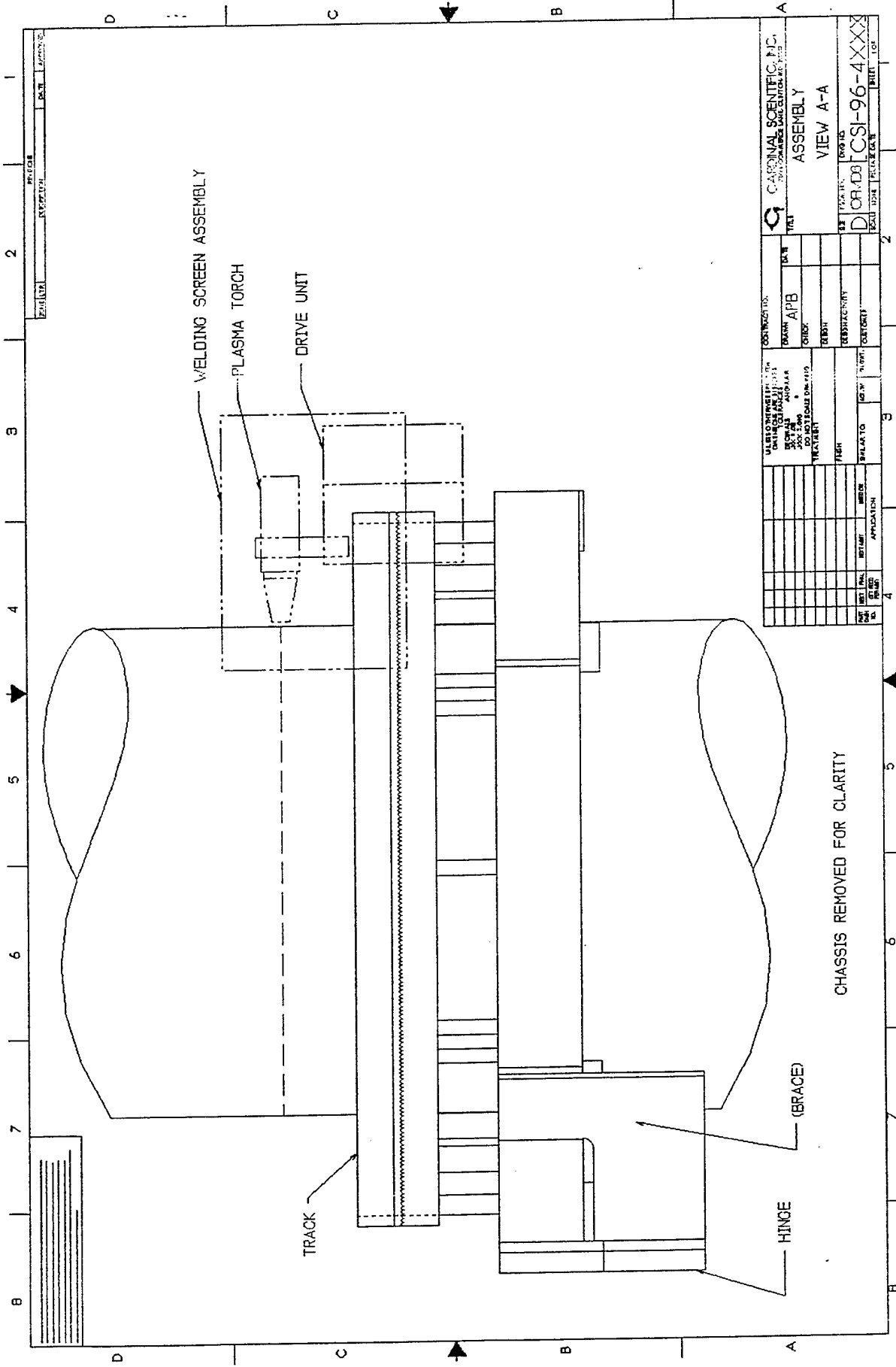

G CARDINAL SCIENTIFIC, INC. 3000 W. 10TH AVE. DENVER, CO 80202		DATE: _____	
ASSEMBLY		VIEW A-A	
DRAWN: _____		CHECKED: _____	
DESIGNED: _____		DATE: _____	
PROJECT NO: _____		SHEET NO: _____	
TOTAL SHEETS: _____		SCALE: _____	
APPROVED: _____		DATE: _____	
TITLE: _____		PROJECT: _____	
SUBJECT: _____		DRAWING NO: _____	
SHEET NO: _____		TOTAL SHEETS: _____	
SCALE: _____		DATE: _____	
PROJECT: _____		DRAWING NO: _____	
SHEET NO: _____		TOTAL SHEETS: _____	
SCALE: _____		DATE: _____	
PROJECT: _____		DRAWING NO: _____	
SHEET NO: _____		TOTAL SHEETS: _____	
SCALE: _____		DATE: _____	

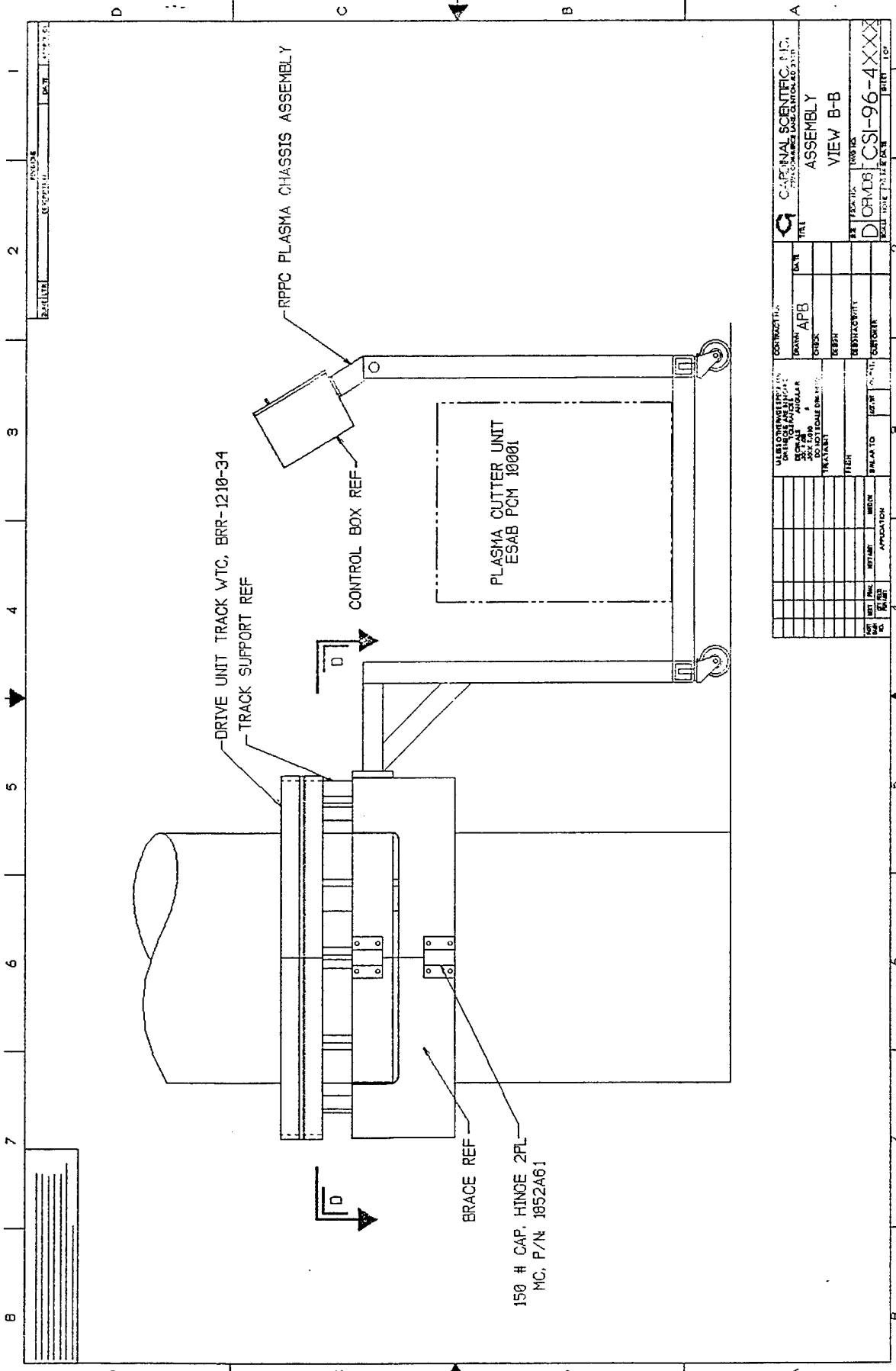

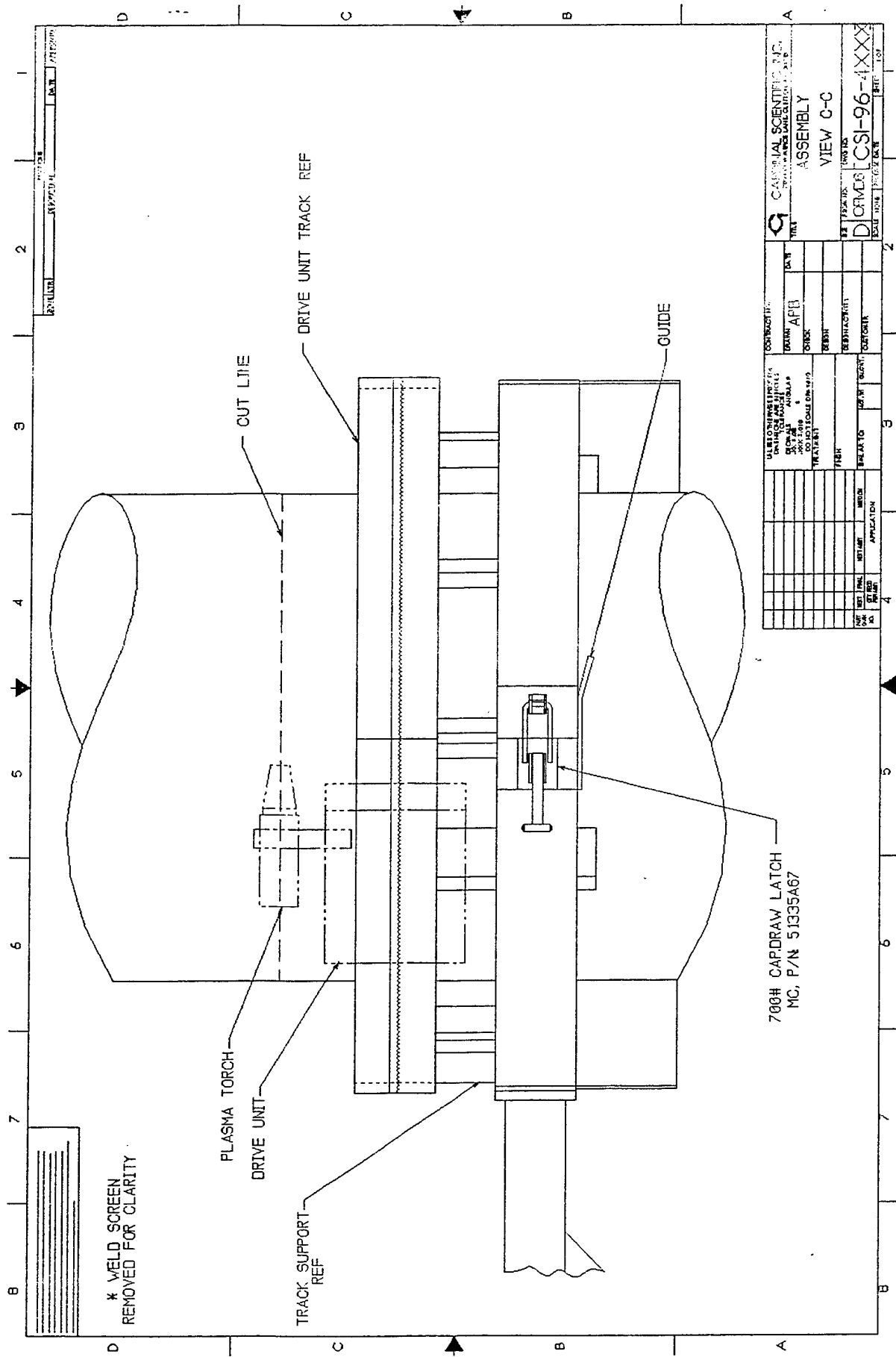

CONTRACTOR: CALSONIC SCIENTIFIC, INC. 10000 WILSON BLVD. FORT WORTH, TEXAS 76150		DATE: _____ DRAWN: APH CHECK: _____ DESIGNED: _____ APPROVED: _____	PART NO.: _____ REV: _____ QUANTITY: _____ UNIT: _____
U.S. GOVERNMENT PROCUREMENT SPECIFICATIONS SECTION 01520 ELECTRICAL CONDUIT SYSTEMS PART 1 CONDUIT SYSTEMS		MATERIAL: _____ FINISH: _____ INSTALLATION: _____ MAINTENANCE: _____ TESTING: _____ INSPECTION: _____	PROJECT NO.: _____ DRAWING NO.: _____ SHEET NO.: _____ TOTAL SHEETS: _____

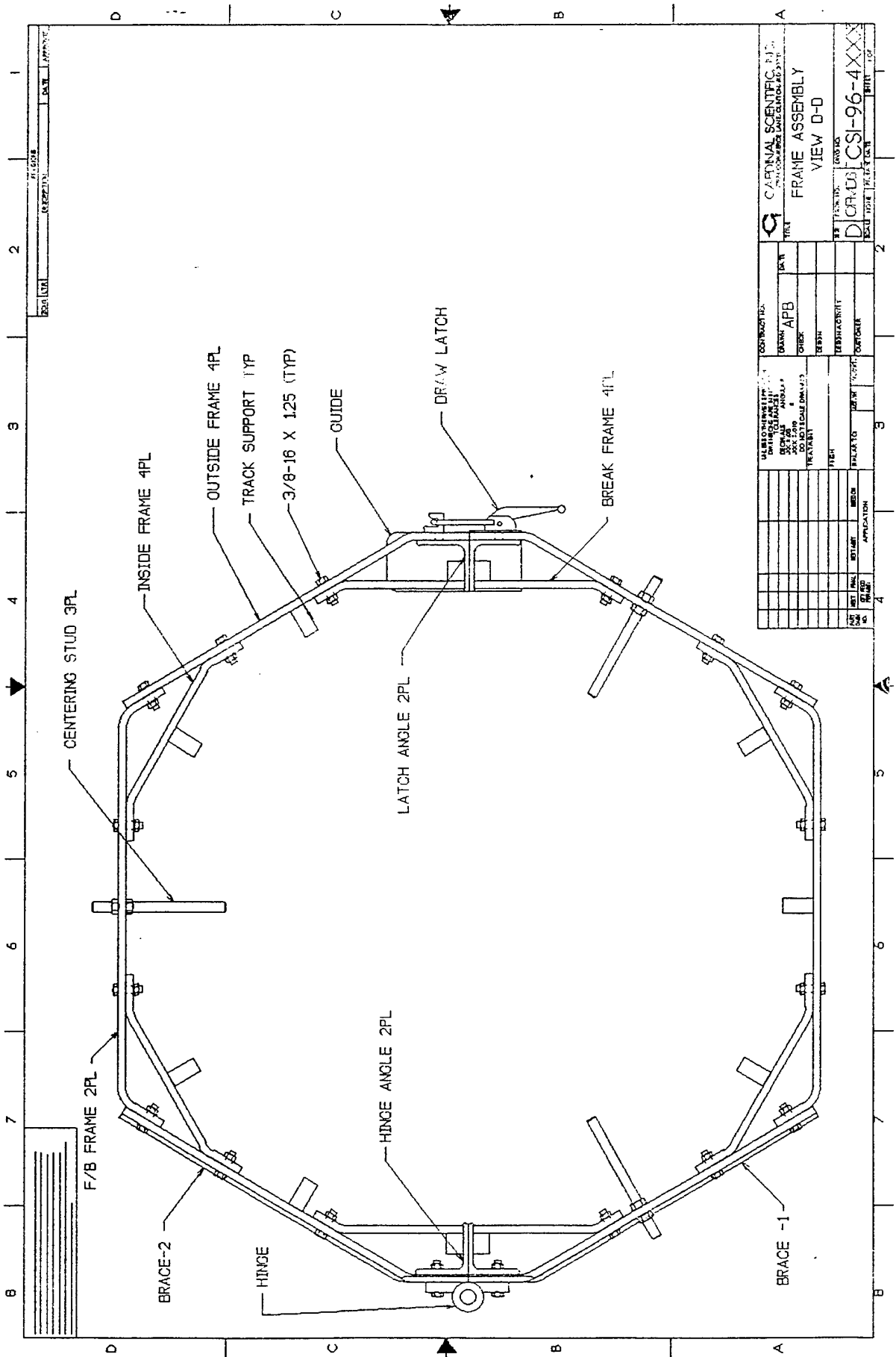

CARDINAL SCIENTIFIC, INC. 1000 W. 10TH ST. S.W. MINNEAPOLIS, MN 55415		TITLE FRAME ASSEMBLY		DATE _____	
DRAWN APB		CHECKED _____		TREATMENT _____	
REVISION _____		TREATMENT _____		BALANCE _____	
PART NO. CS-96-4XXX		SCALE _____		SHEET NO. _____	

CITY: 4
 OUTSIDE FRAME
 MATERIAL: 3/8 X 4.0, 6061-T6

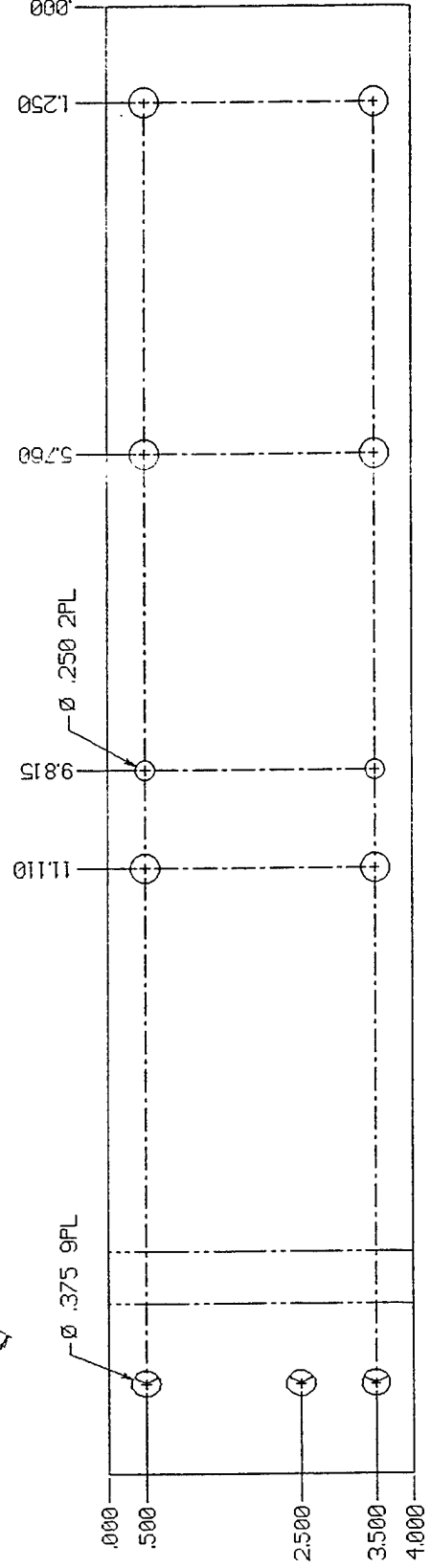
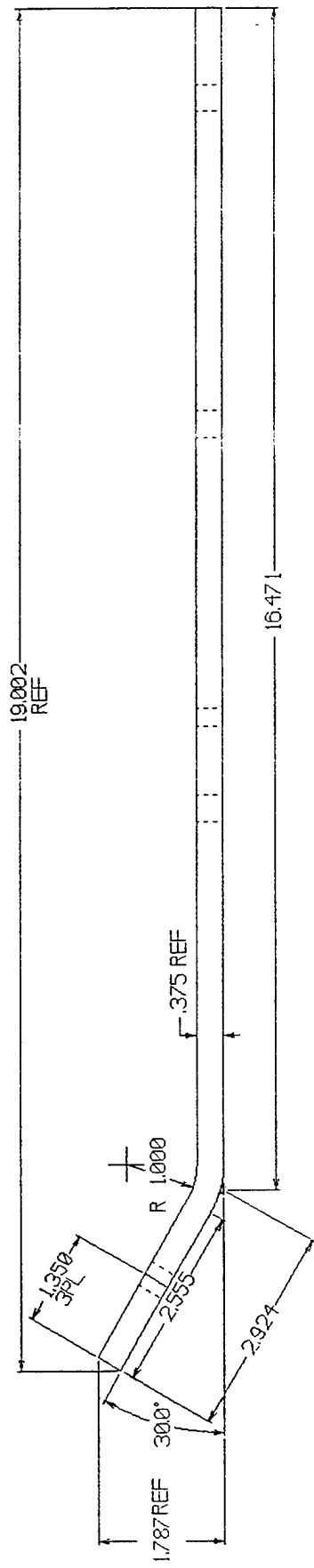

QTY: 4
 INSIDE FRAME
 MATERIAL: 3/8 X 4.0, 6061-T6

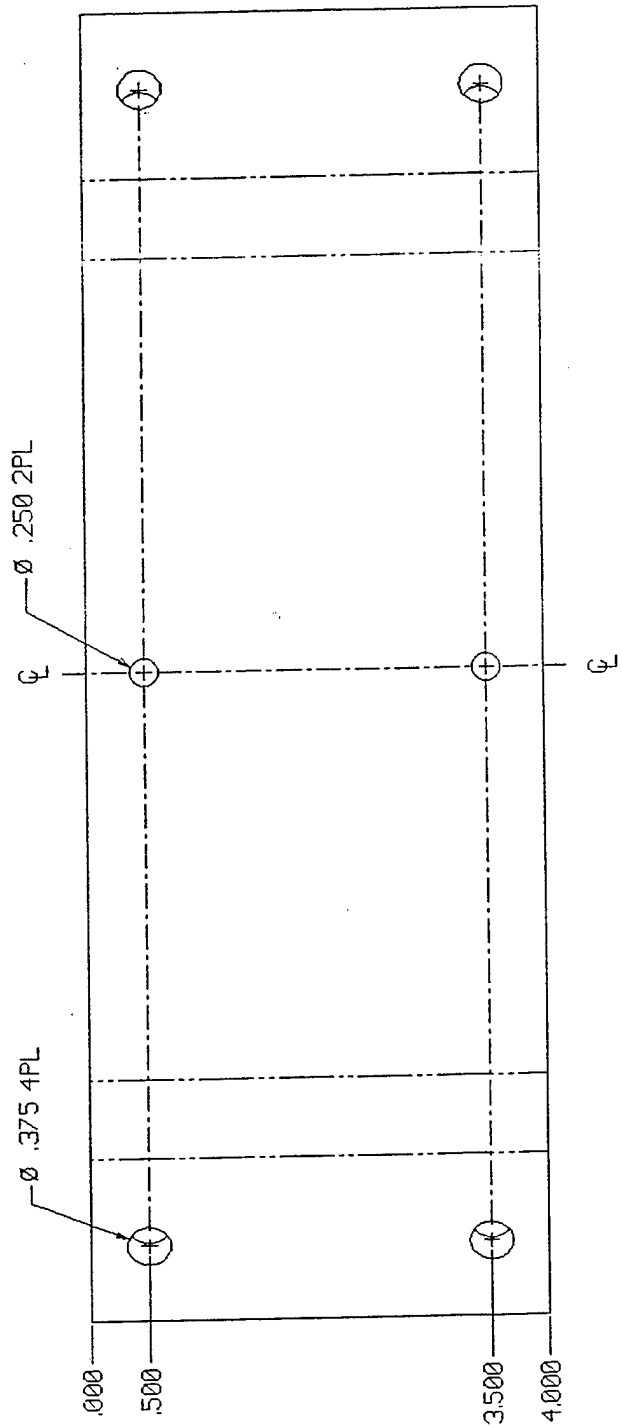
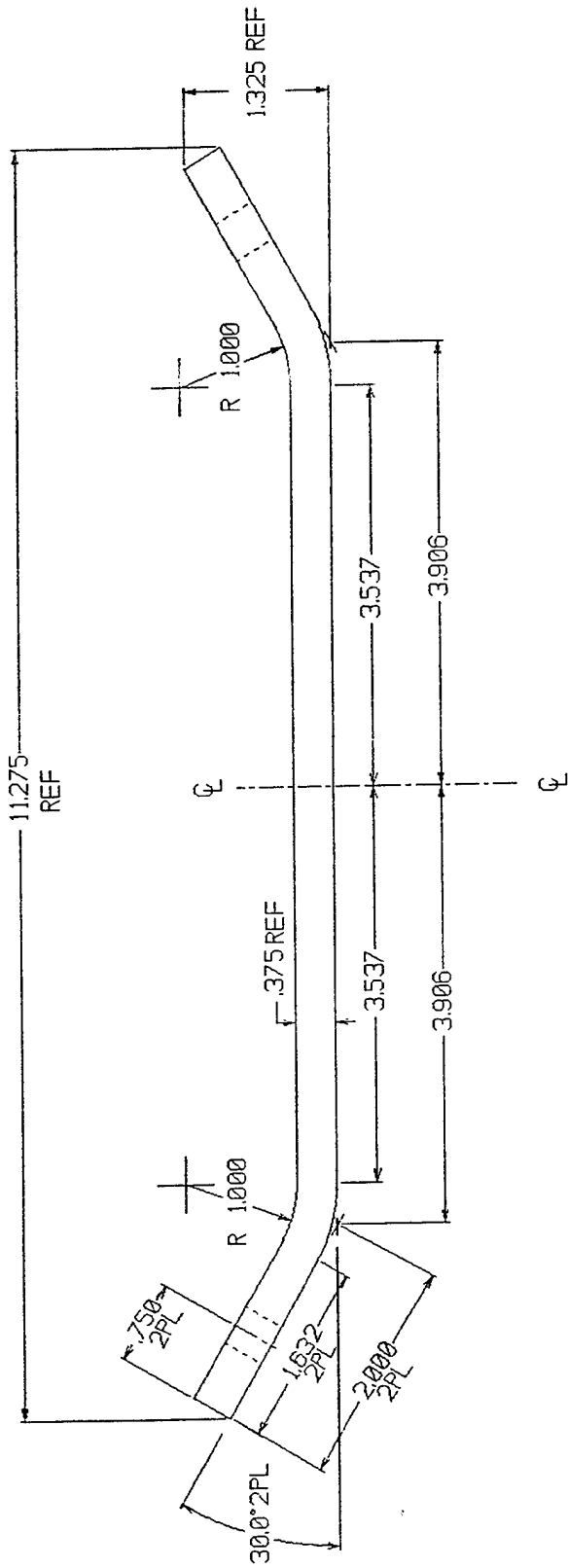

QTY: 4
BREAK FRAME
MATERIAL: 3/8 X 40, 6061-T6

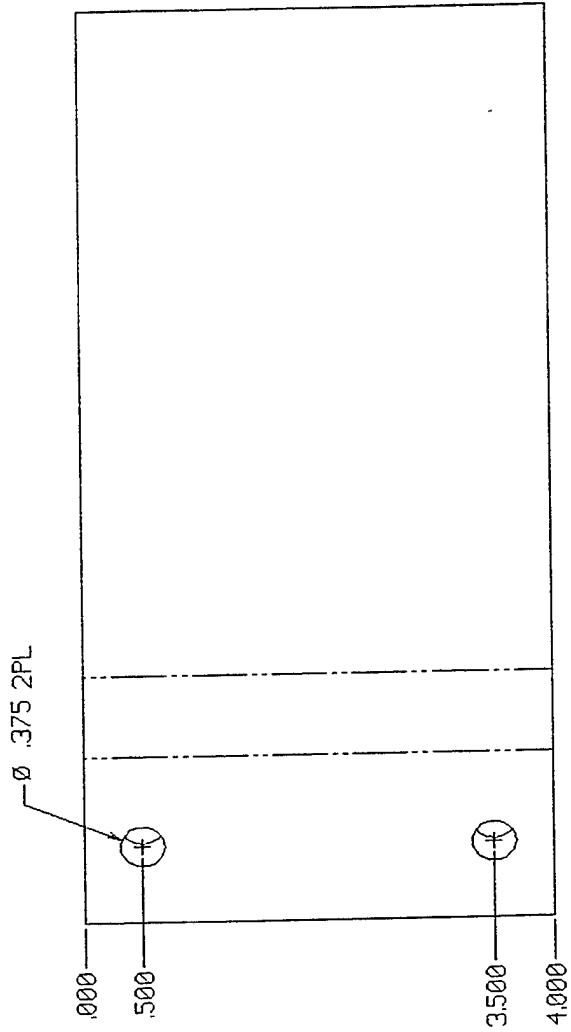
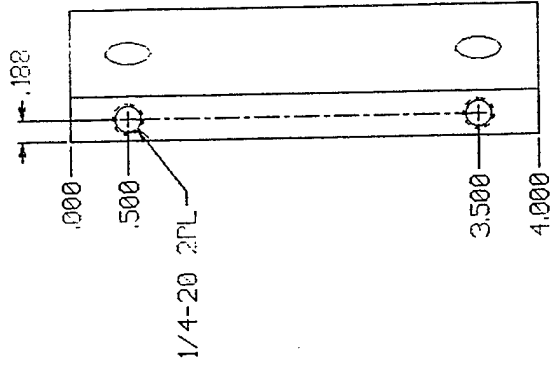
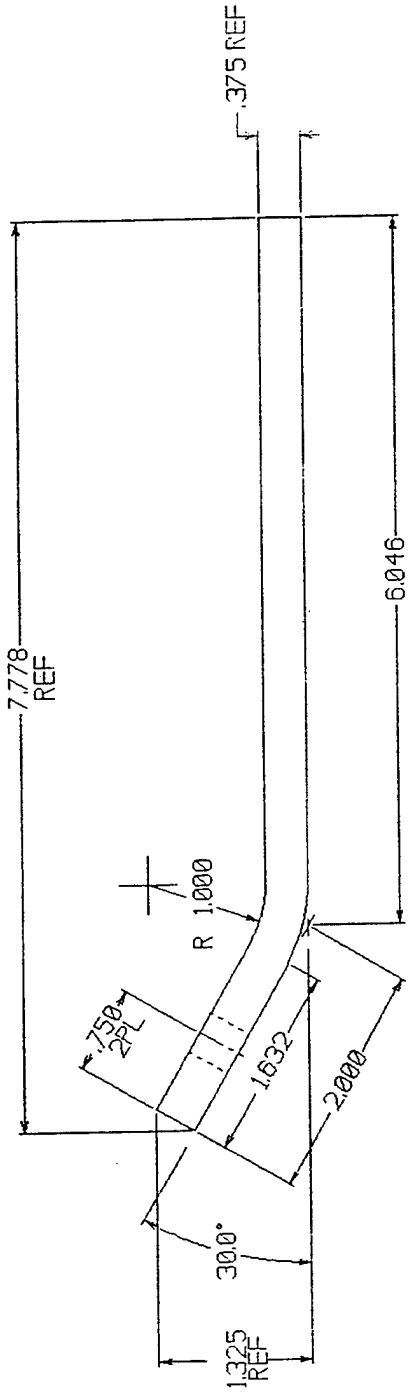

QTY: 11
TRACK SUPPORT
MATERIAL: AL, 6061-T6

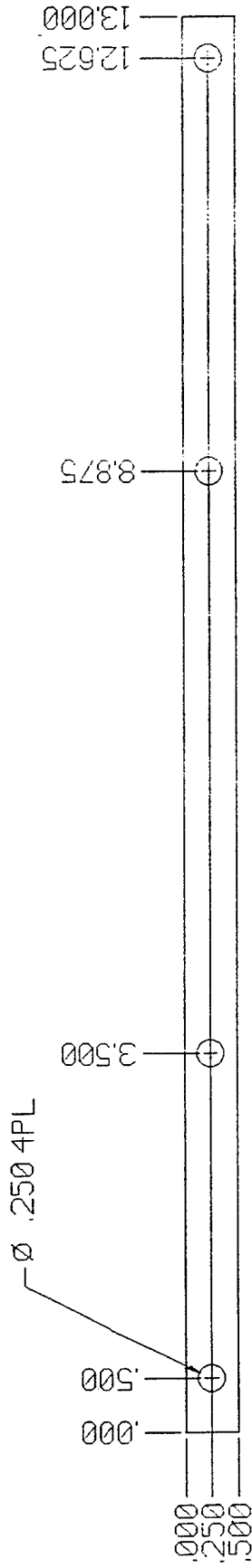
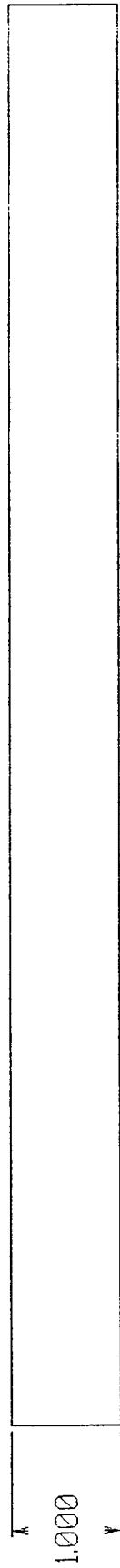

QTY: 3

CENTERING STUD

MATERIAL: 1/2-13 ALL THREAD

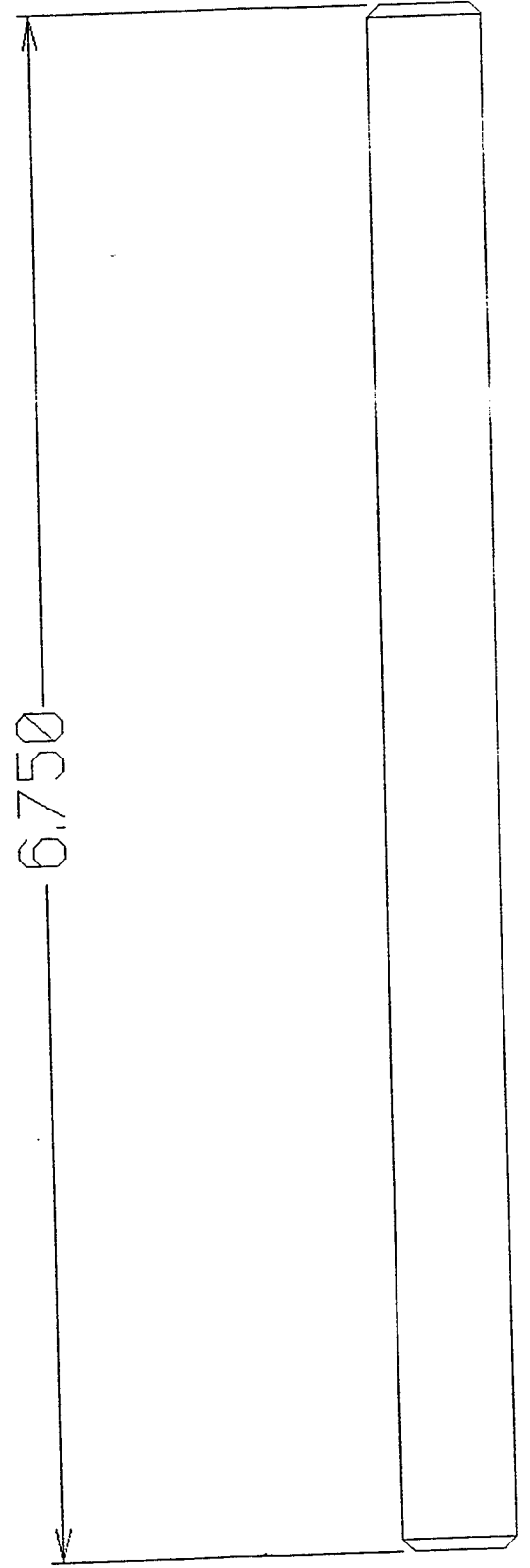

QTY: 1
GUIDE
MAT'L: 1/4" ALUMINUM

NOTE HOLE ORIENTATION BEFORE BENDING

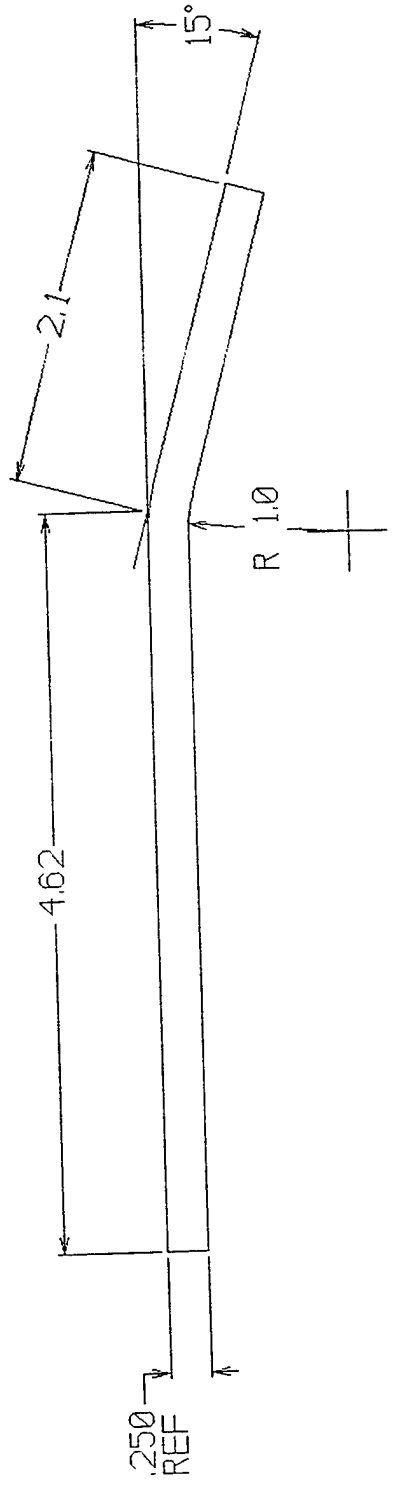
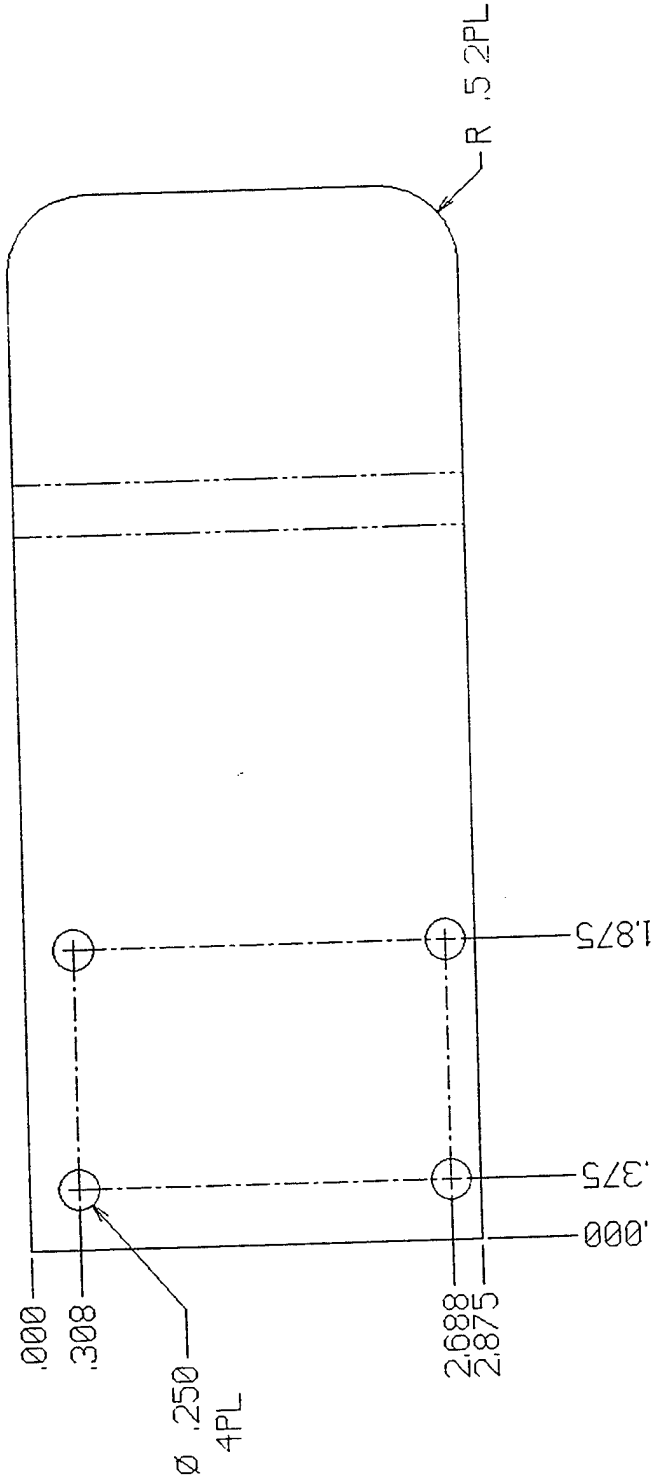

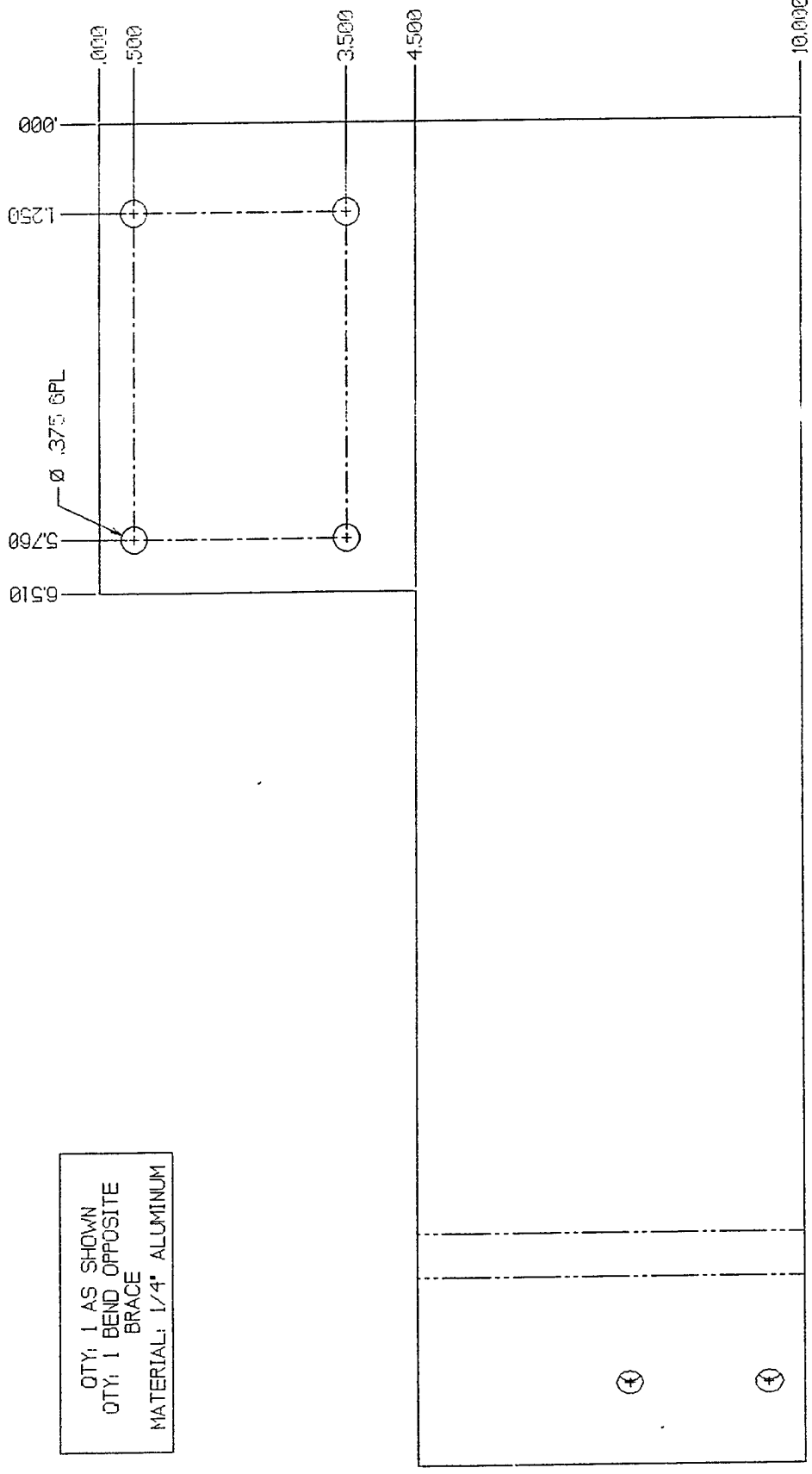
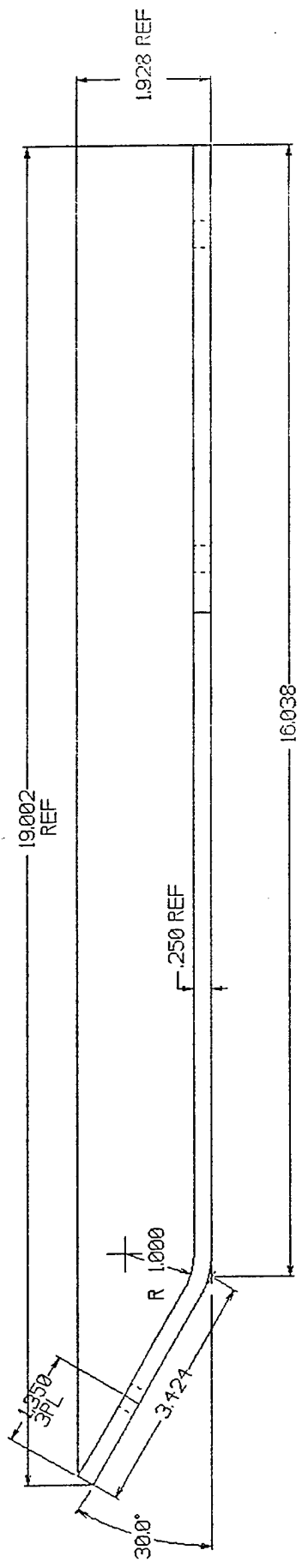

QTY: 1 AS SHOWN
 QTY: 1 BEND OPPOSITE
 BRACE
 MATERIAL: 1/4" ALUMINUM

QTY: 2
LATCH ANGLE
MATERIAL: AL, 6061-T6

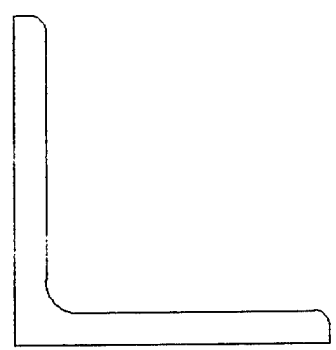
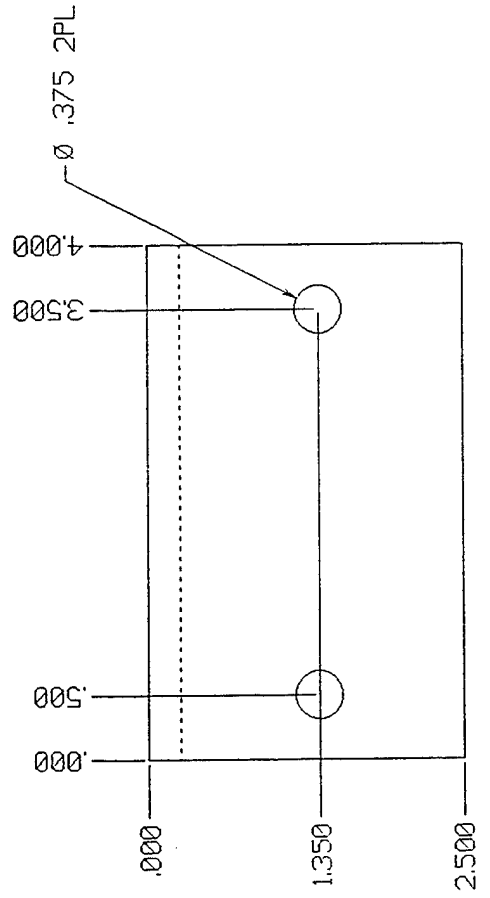
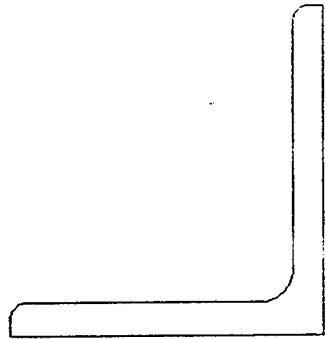
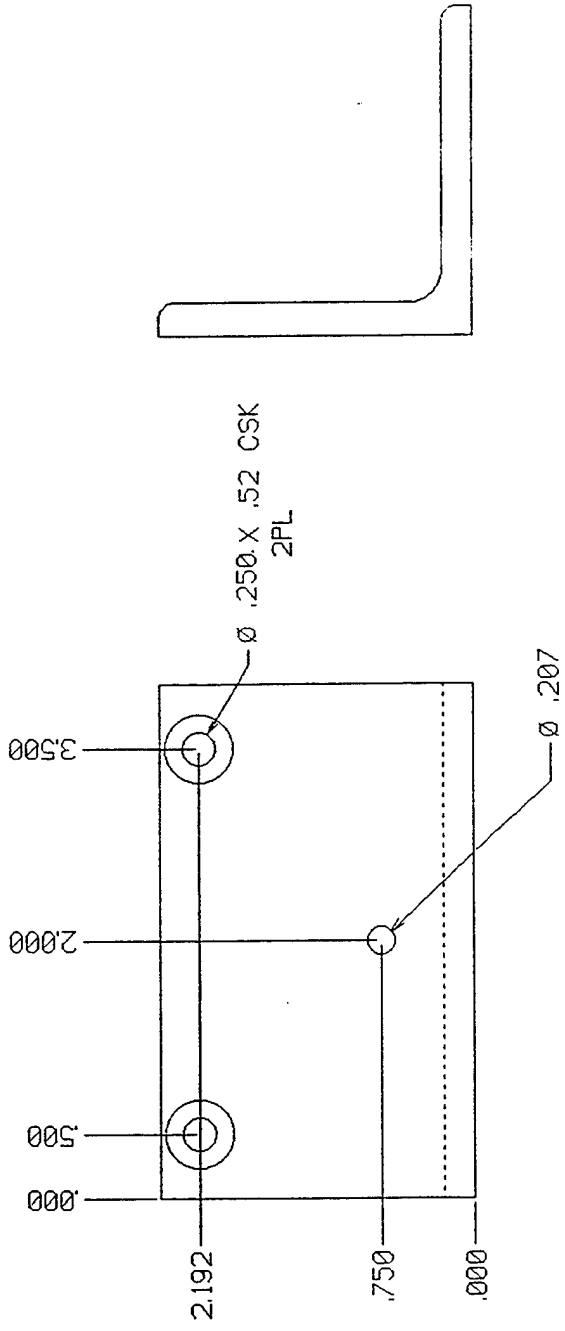

QTY: 1 AS SHOWN, 1 OPPOSITE
 HINGE ANGLE
 MATERIAL: AL, 6061-T6

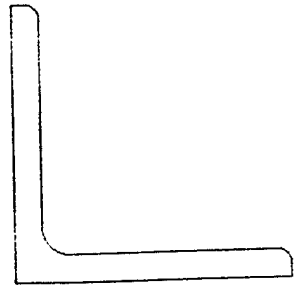
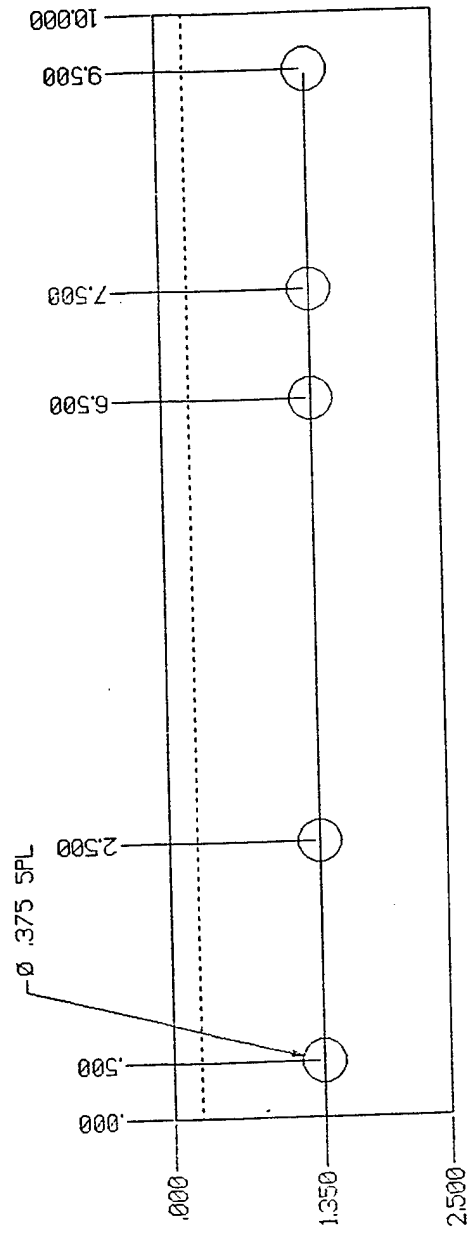
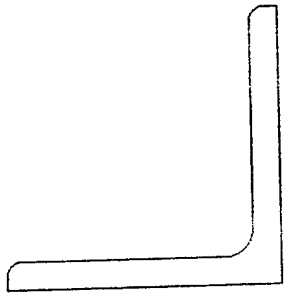
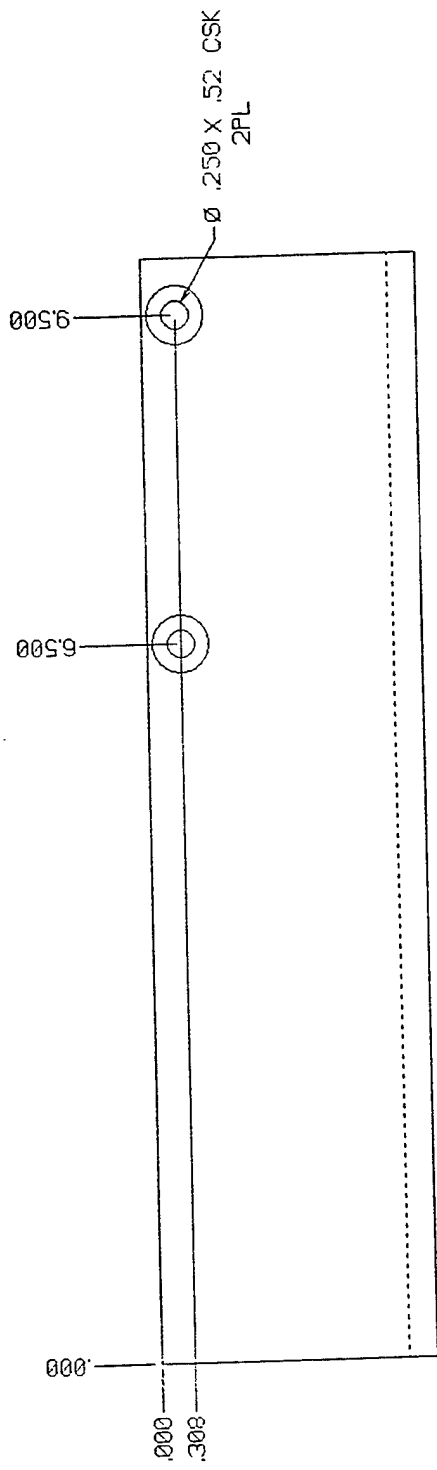

QTY: 1
CROSS FRAME, WELD SCREEN
MATERIAL: 1/8" ALUMINUM

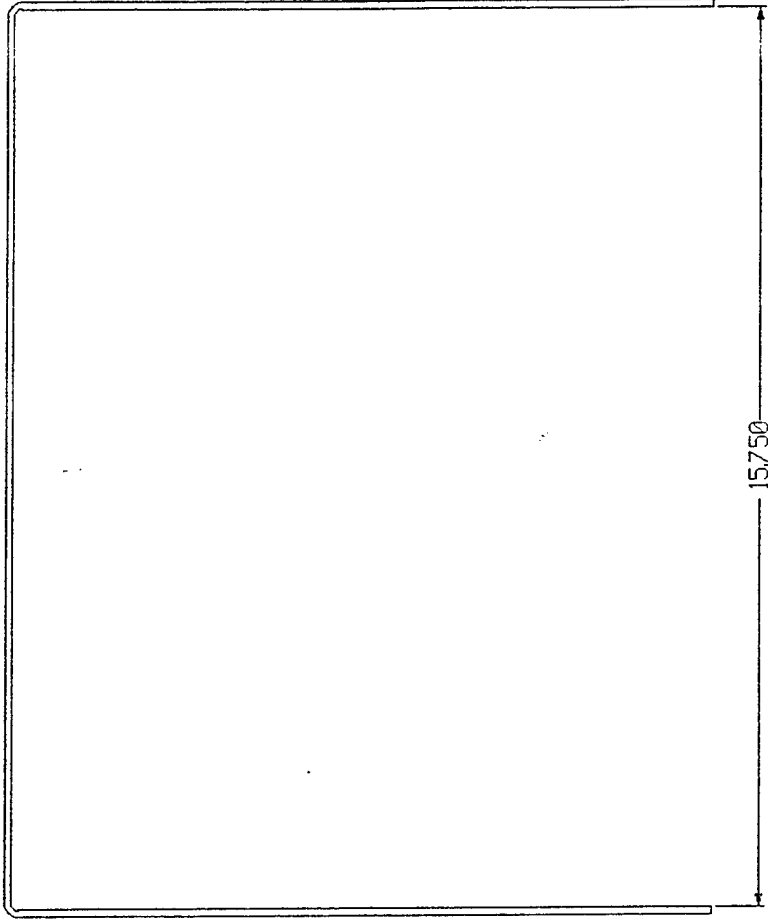
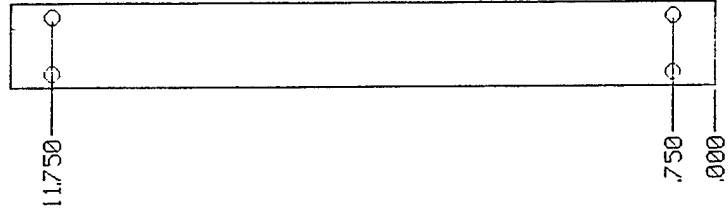
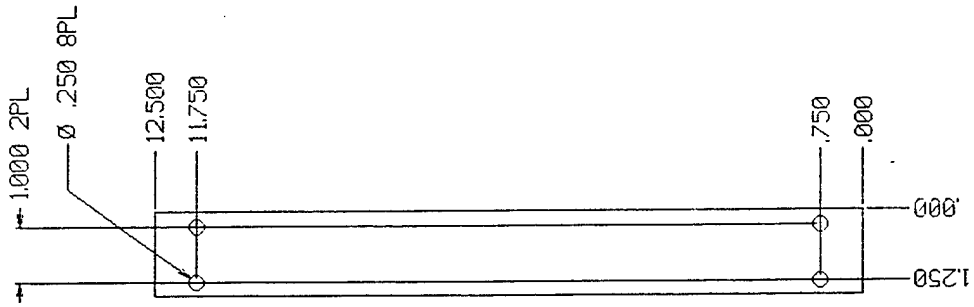

QTY: 1
VERTICAL RIB, WELD SCREEN
MATERIAL: 1/8" ALUMINUM

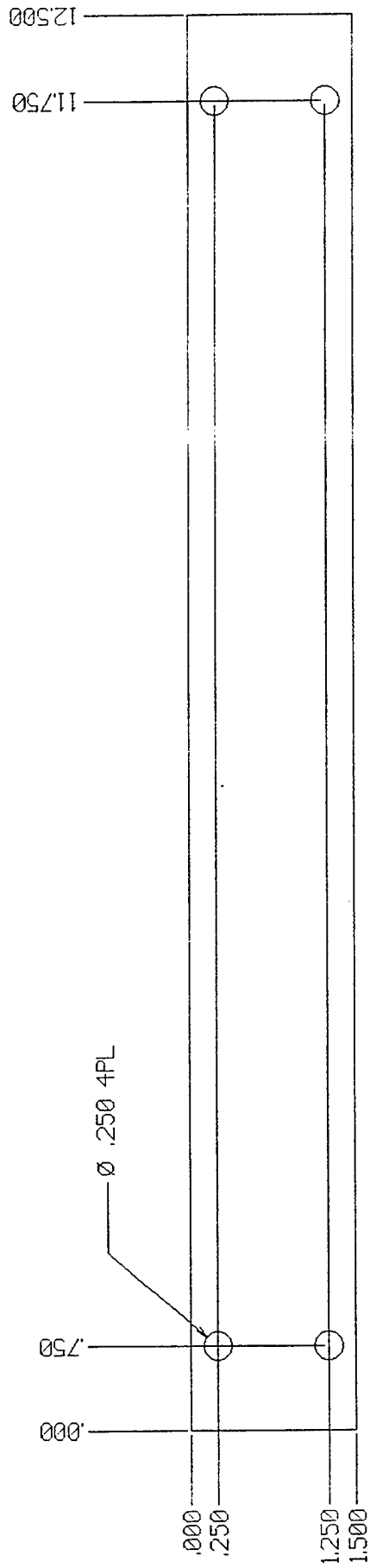

QTY: 2
U/L FRAME, WELD SCREEN
MATERIAL: 1/8" ALUMINUM

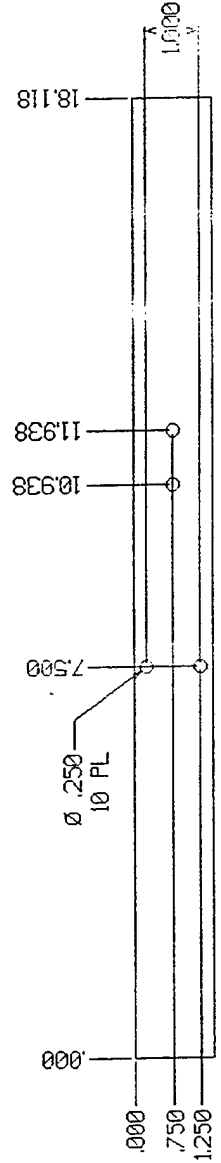
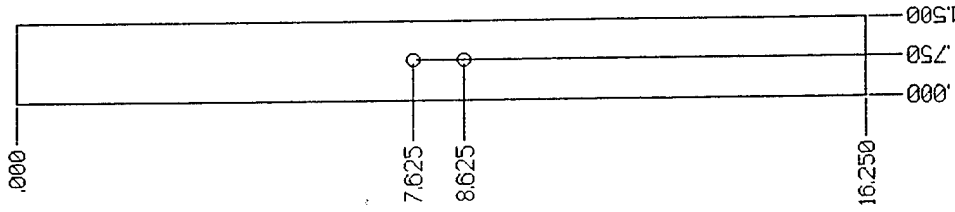
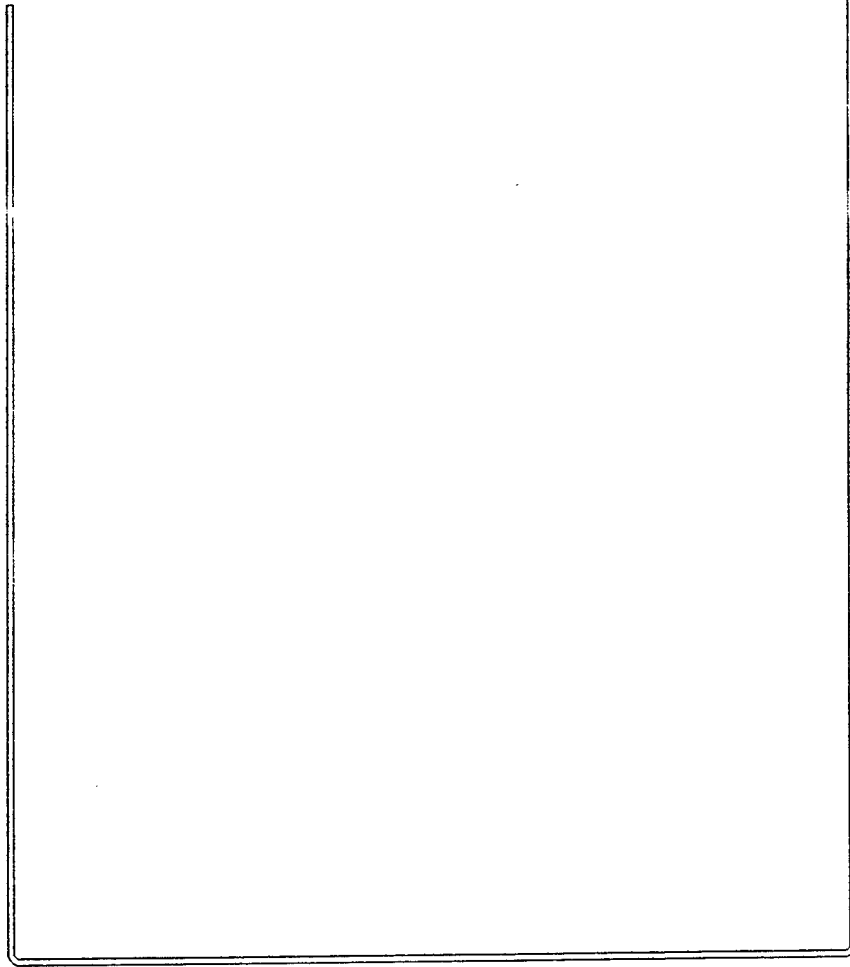

QTY: 2
BRACKET, WELD SCREEN
MATERIAL: 1/8" ALUMINUM

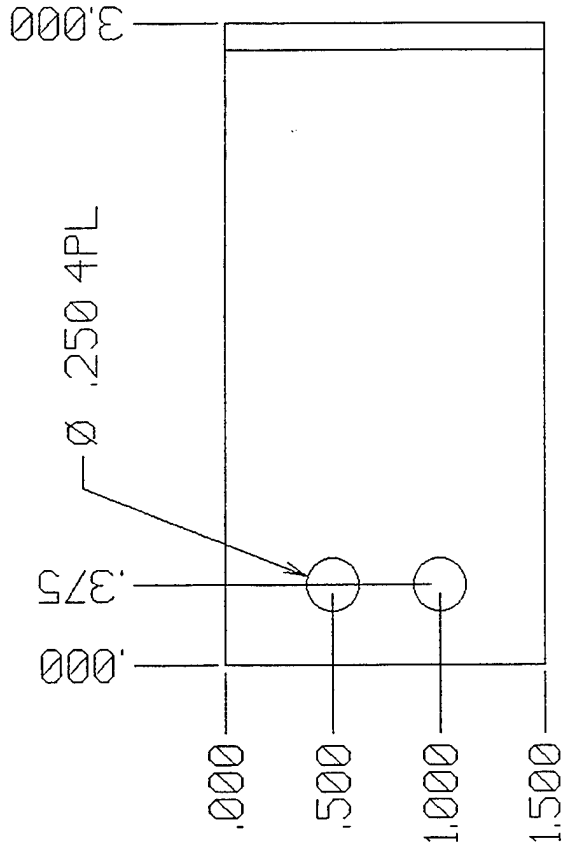
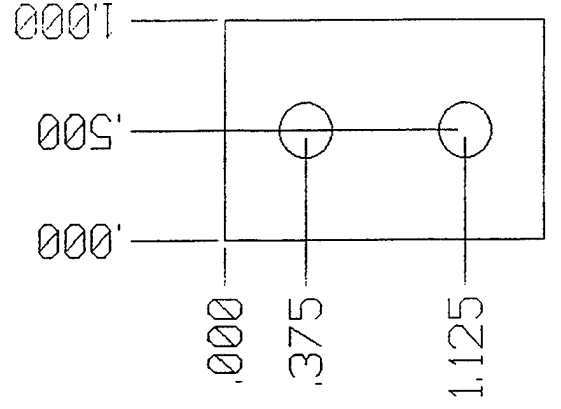
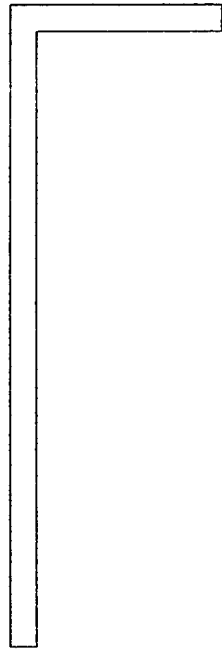

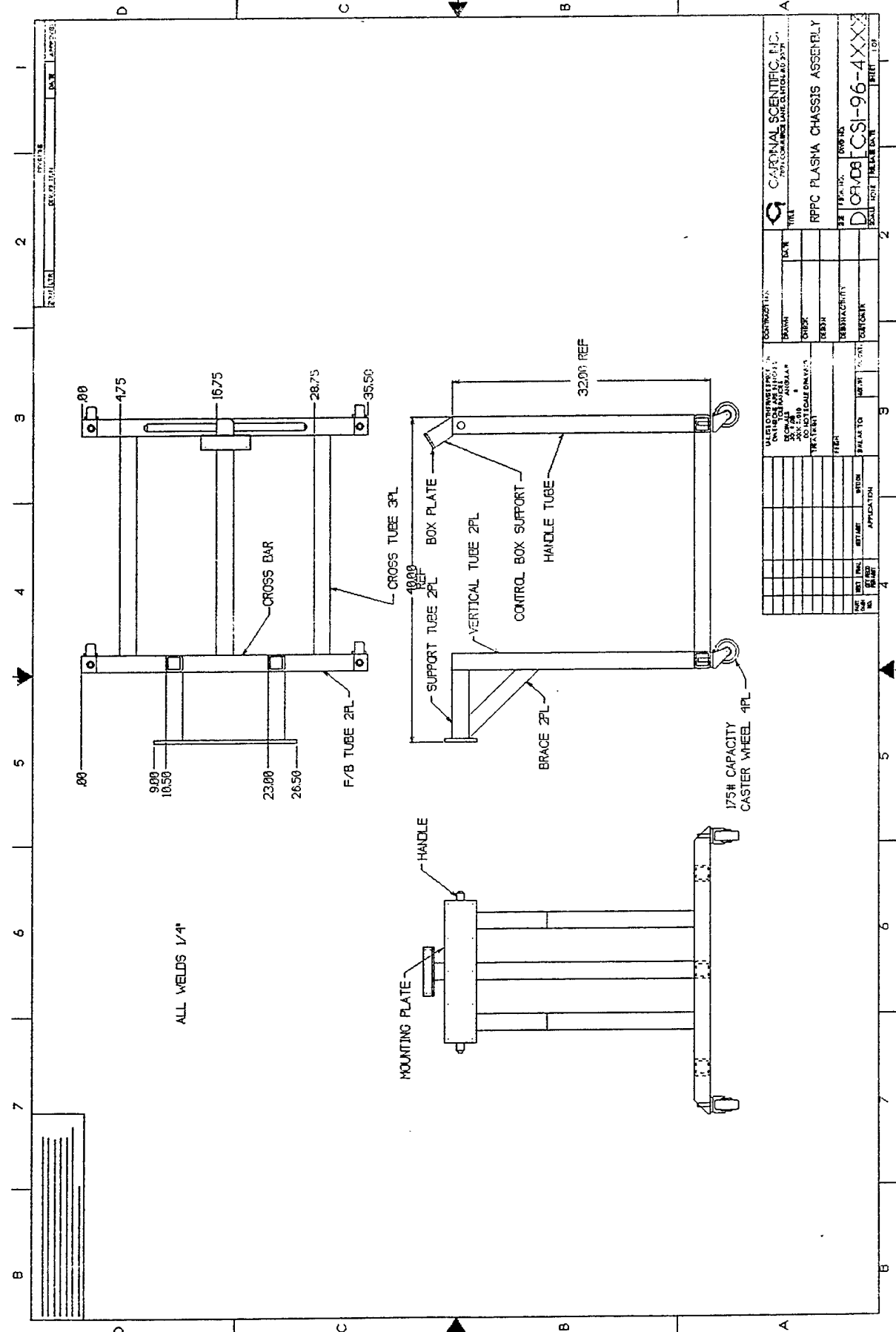

CARDINAL SCIENTIFIC, INC. 2911 COMMERCE LANE, SUITE 403 DALLAS, TEXAS 75246	
RPPC PLASMA CHASSIS ASSEMBLY	
DATE: _____ DRAWN BY: _____ CHECKED BY: _____ APPROVED BY: _____	PART NO: CSI-96-4XXX SCALE: _____ SHEET NO: _____ OF _____

F/B TUBE

QTY: 2

MATERIAL 2X2X.25 STEEL

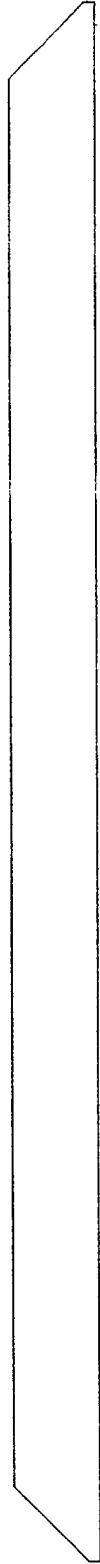
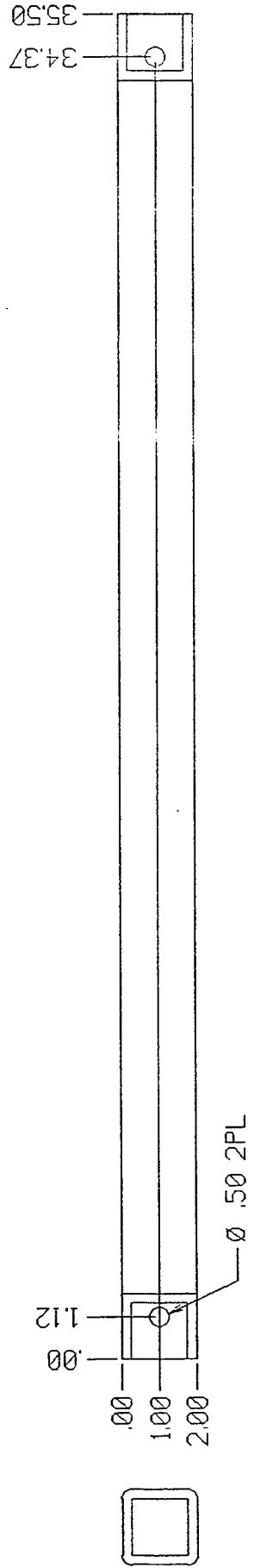

RPPC TUBE DETAILS

TUBE	QTY	L
CROSS TUBE	3	27.0
SUPPORT TUBE	2	8.5
VERTICAL TUBE	2	30.0
CROSS BAR	1	10.5

MATERIAL: 2X2X.25 STEEL

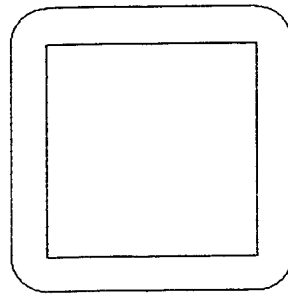
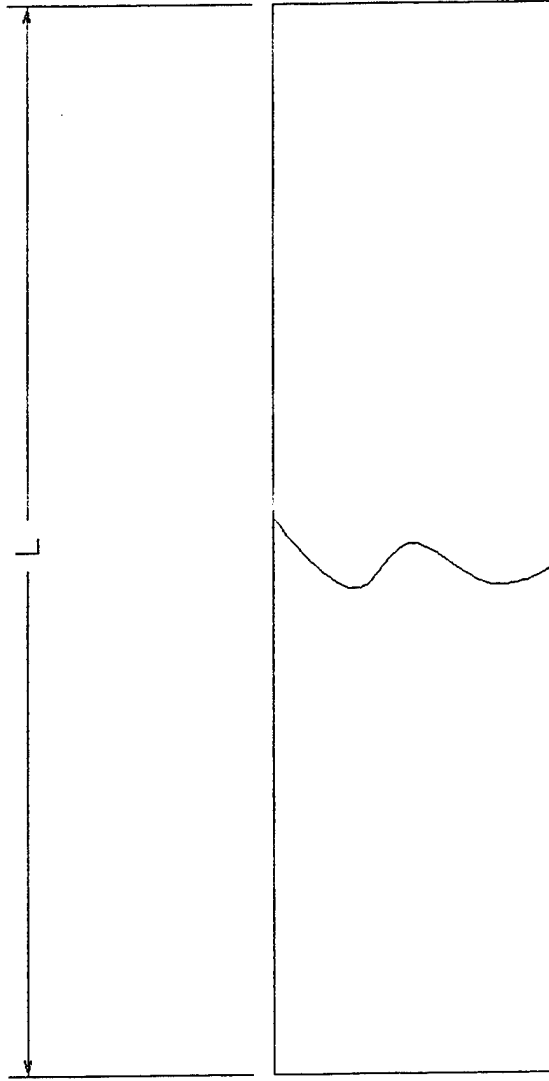

BRACE TUBE

QTY: 2

MATERIAL: 2X2X.25 STEEL

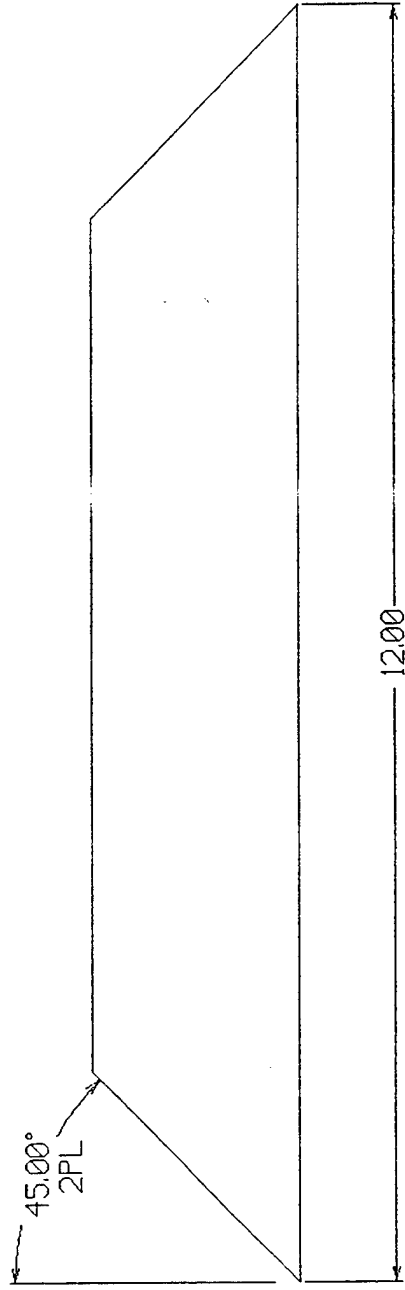
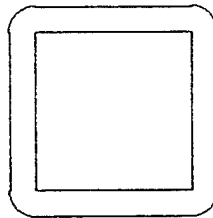

CONTROL BOX SUPPORT

QTY: 1

MATERIAL: 2X2X.25 STEEL

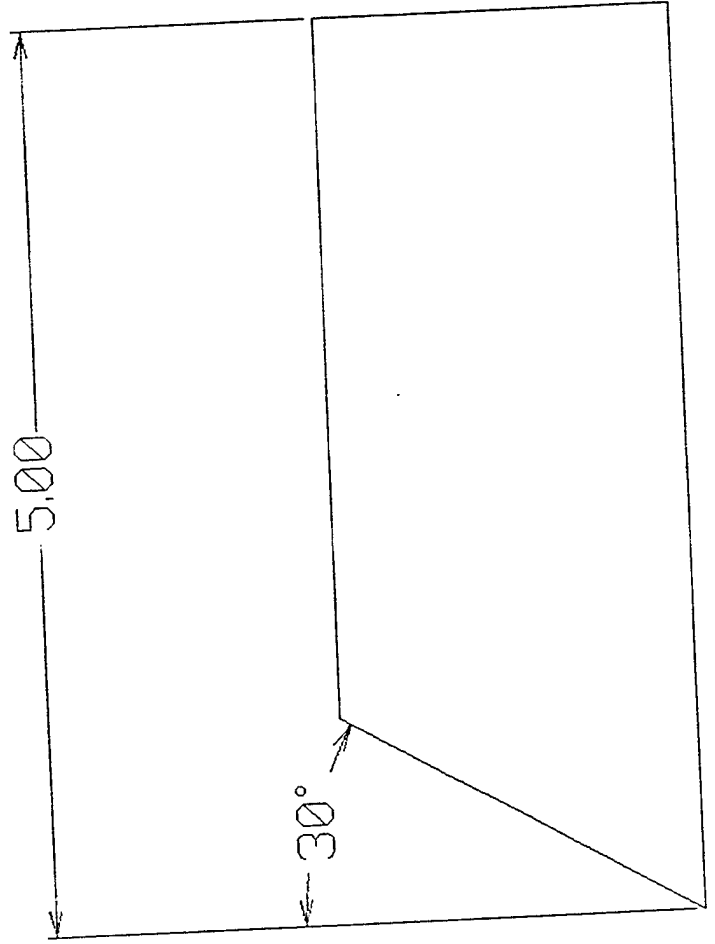
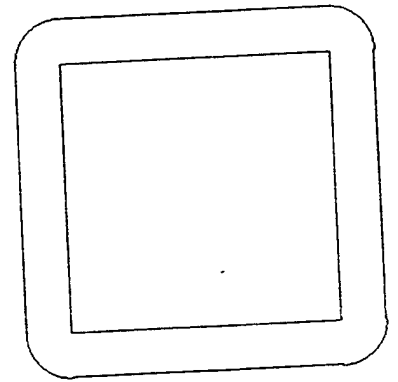

HANDLE

QTY: 1

MATERIAL: 1" DIA STEEL

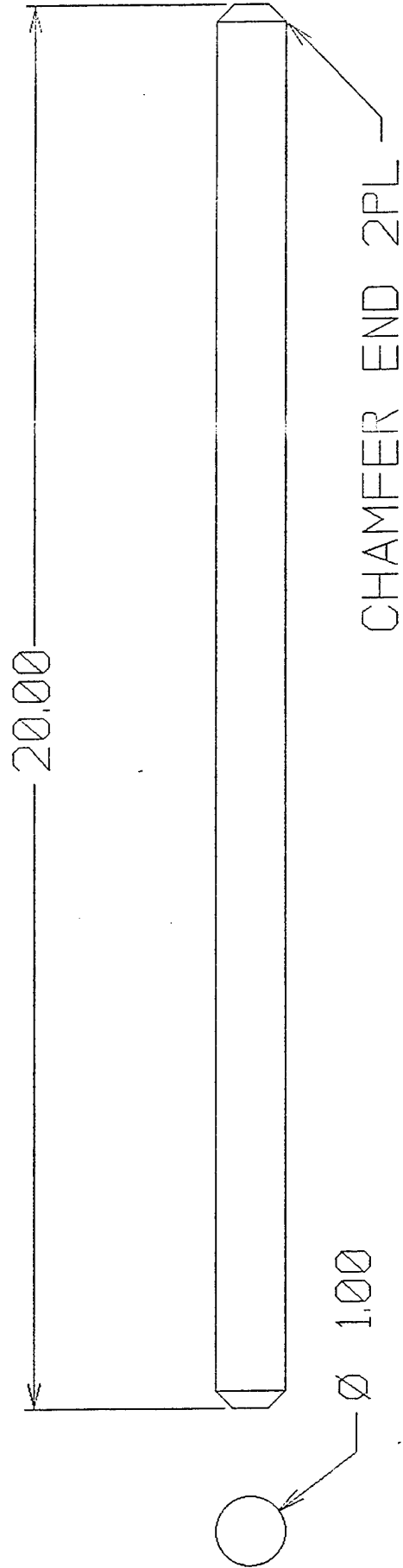

MOUNTING PLATE

QTY:1

MATERIAL: 1/2 X 4 C.R.S.

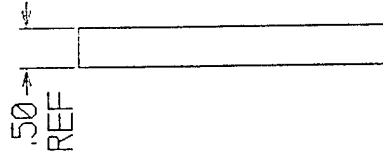
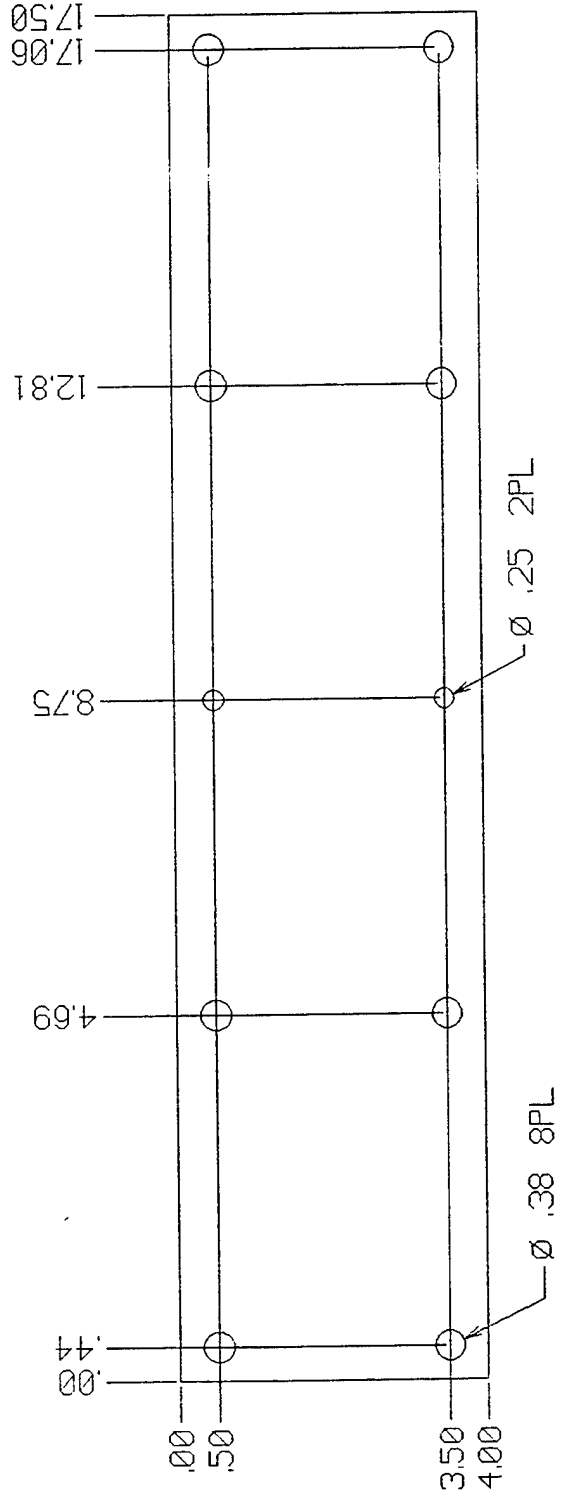

BOX PLATE

QTY:1

MATERIAL: 1/4 X 2 STEEL

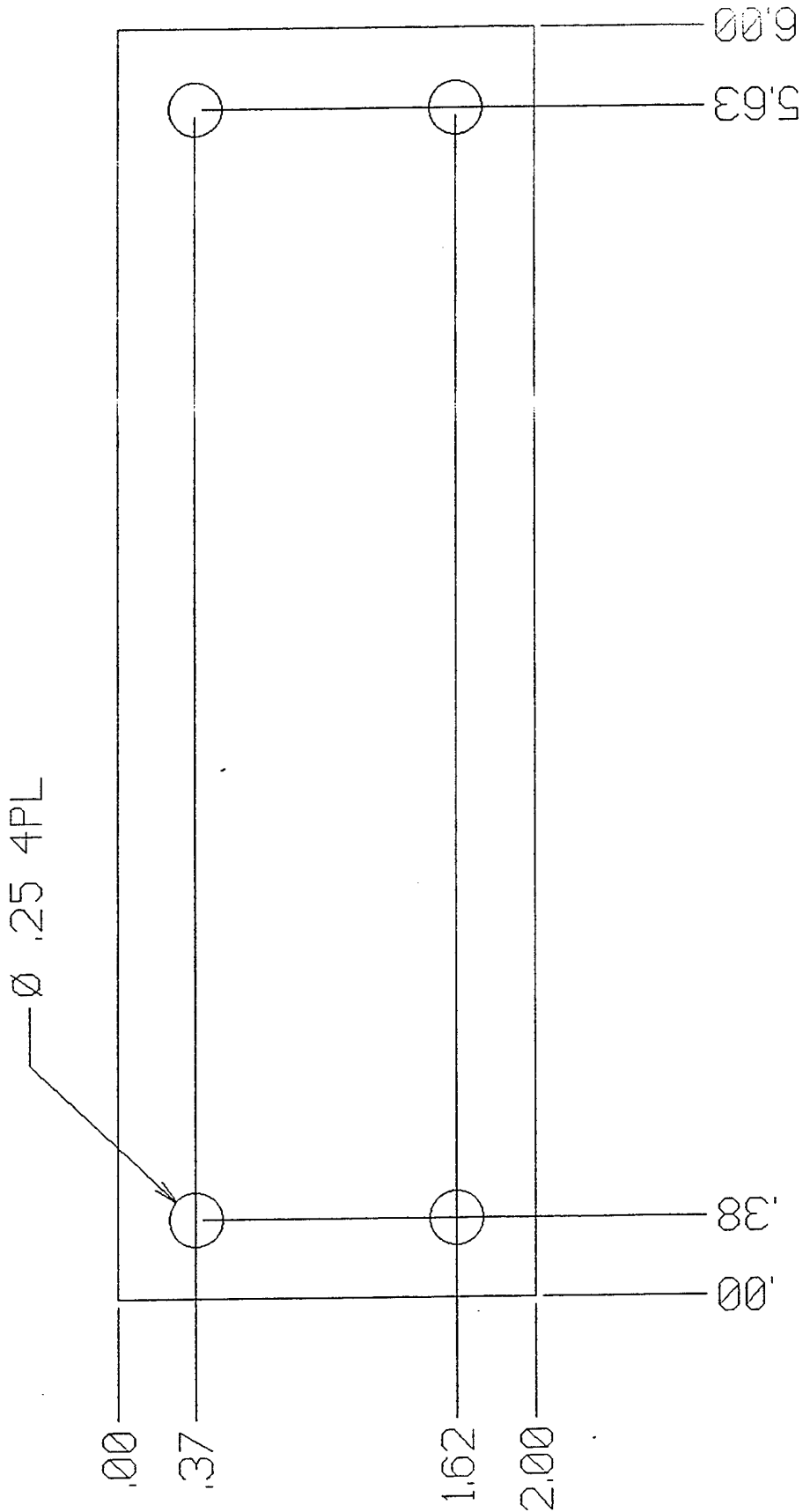

Appendix B - Prototype RPPC Calculations

RPPC WHEEL CAPACITY

CALCULATIONS

PAGE 1 OF 1

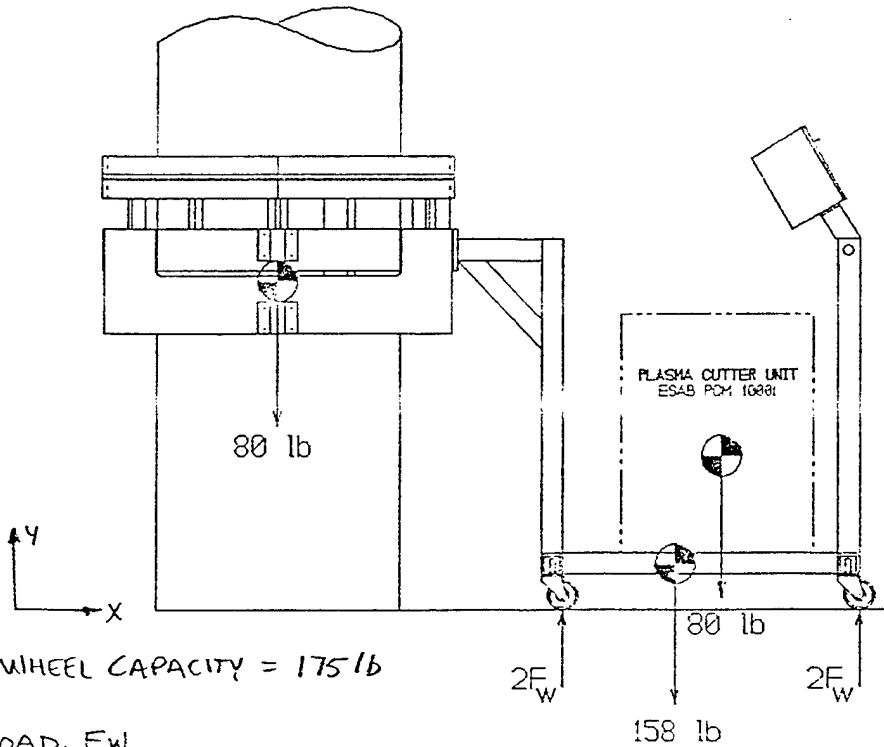

GIVEN:

CASTER WHEEL CAPACITY = 175 lb

FIND:

WHEEL LOAD, F_w

SOLUTION:

$$\sum F_y = 0;$$

$$2F_w + 2F_w = 80 \text{ lb} + 80 \text{ lb} + 158 \text{ lb}$$

$$4F_w = 318 \text{ lb}$$

$$F_w = \frac{318 \text{ lb}}{4}$$

$$F_w = 79.5 \text{ lb}$$

$$\text{SAFETY MARGIN} = \frac{175 \text{ lb}}{79.5} = \underline{\underline{2.20}} \text{ S.M.}$$

← WHEEL LOAD

CSI QBS

Appendix C - Prototype HPG Detailed Design Drawings

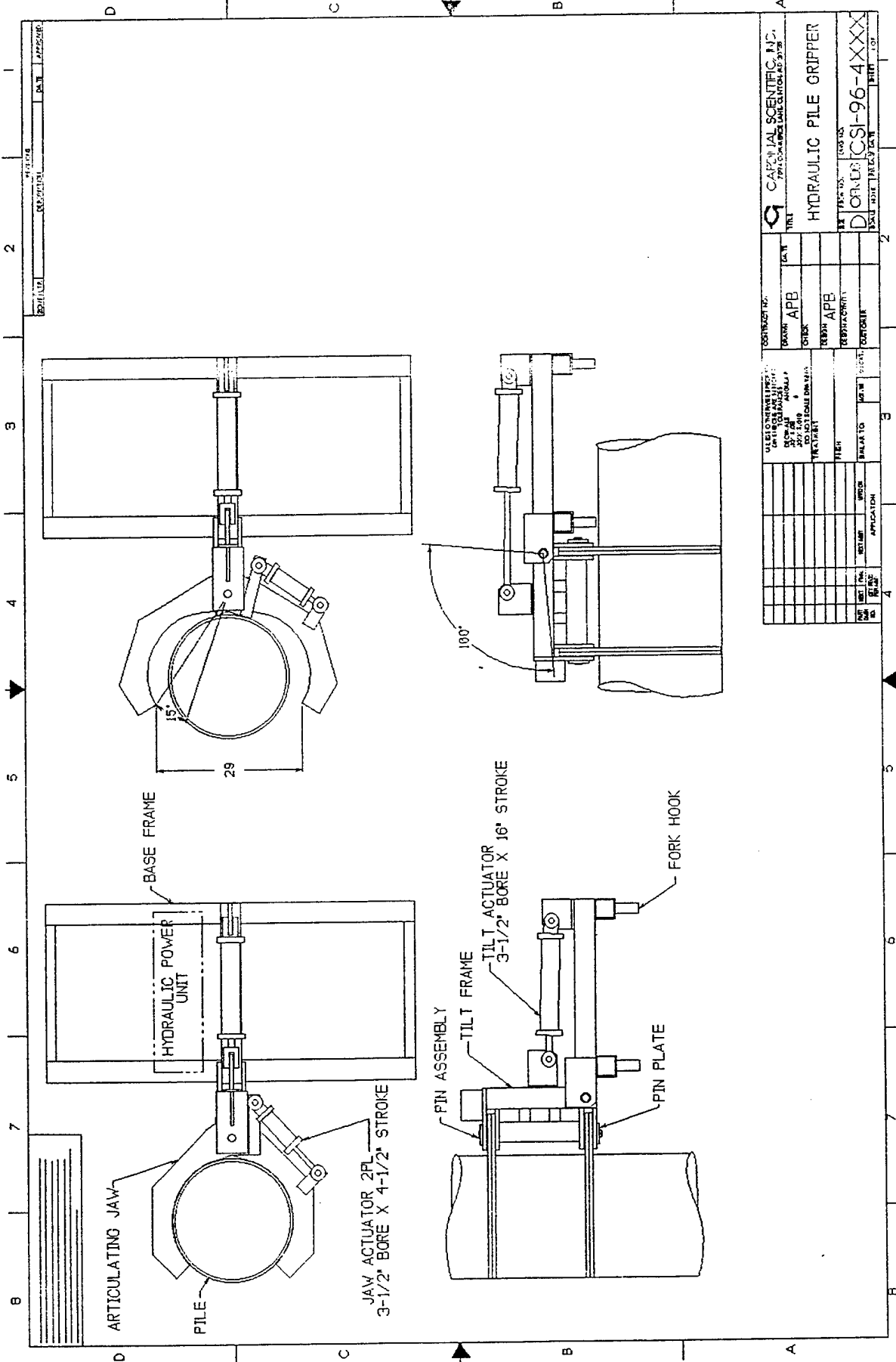

DATE	APPROVER

CAPITIAL SCIENTIFIC, INC. 1715 S. W. 10TH AVE. MIAMI, FL 33135	
HYDRAULIC PILE GRIPPER	
PROJECT NO.	CSJ-96-4XXX
DATE	
DESIGNER	
CHECKER	
APPROVER	
DATE	
SCALE	
UNIT	
CONTRACT NO.	
OWNER	
DESIGNER	
CONTRACTOR	
DATE	
SCALE	
UNIT	
CONTRACT NO.	
OWNER	
DESIGNER	
CONTRACTOR	
DATE	
SCALE	
UNIT	

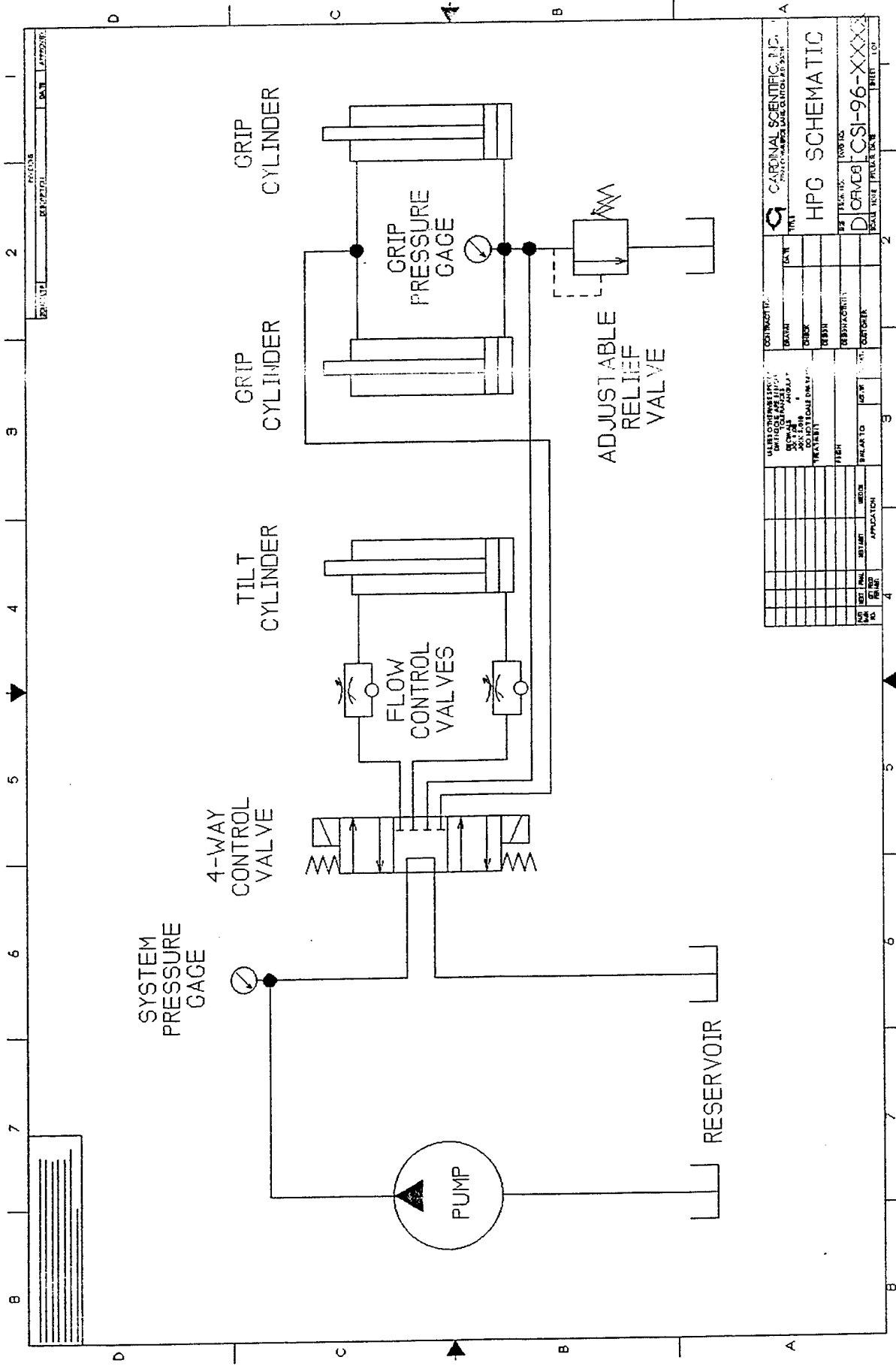

CAVENDISH SCIENTIFIC, INC. 1000 W. 10th St. • Denver, CO 80202	
HPG SCHEMATIC	
DATE: _____ DRAWN BY: _____ CHECKED BY: _____ DESIGNED BY: _____ APPROVED BY: _____	PROJECT NO: _____ DRAWING NO: CSI-96-XXXX SCALE: _____ SHEET NO: _____ TOTAL SHEETS: _____
USE THIS SCHEMATIC FOR: - GENERAL INFORMATION - SPECIFIC APPLICATIONS - TROUBLESHOOTING - MODIFICATIONS - SAFETY PRECAUTIONS	COMMENTS: - _____ - _____ - _____
PART NO. _____ QTY. _____ UNIT _____ APPLICATION _____	PART NO. _____ QTY. _____ UNIT _____ APPLICATION _____

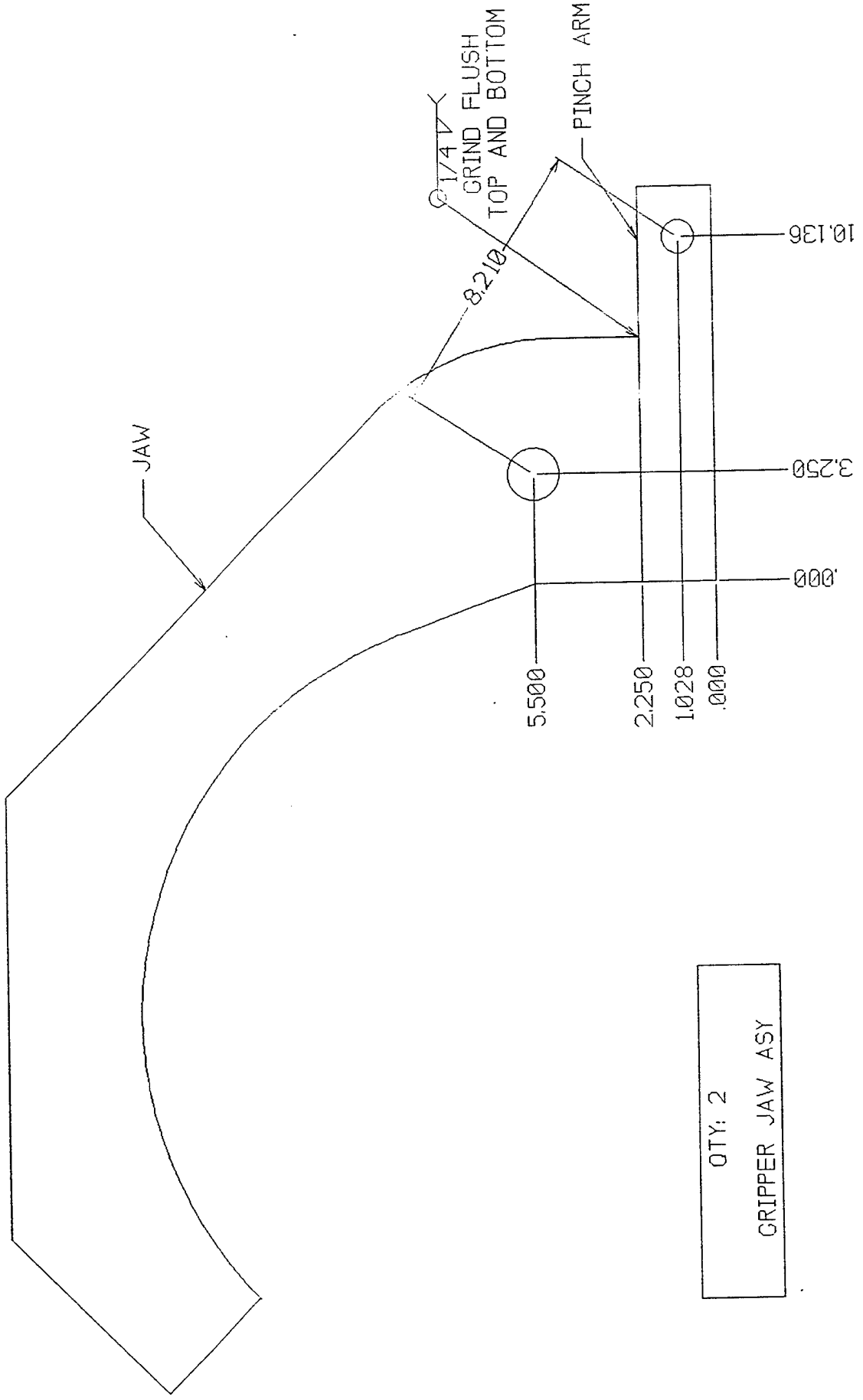

QTY: 2
 CRIPPER JAW ASY

QTY: 1
PIN ASSEMBLY

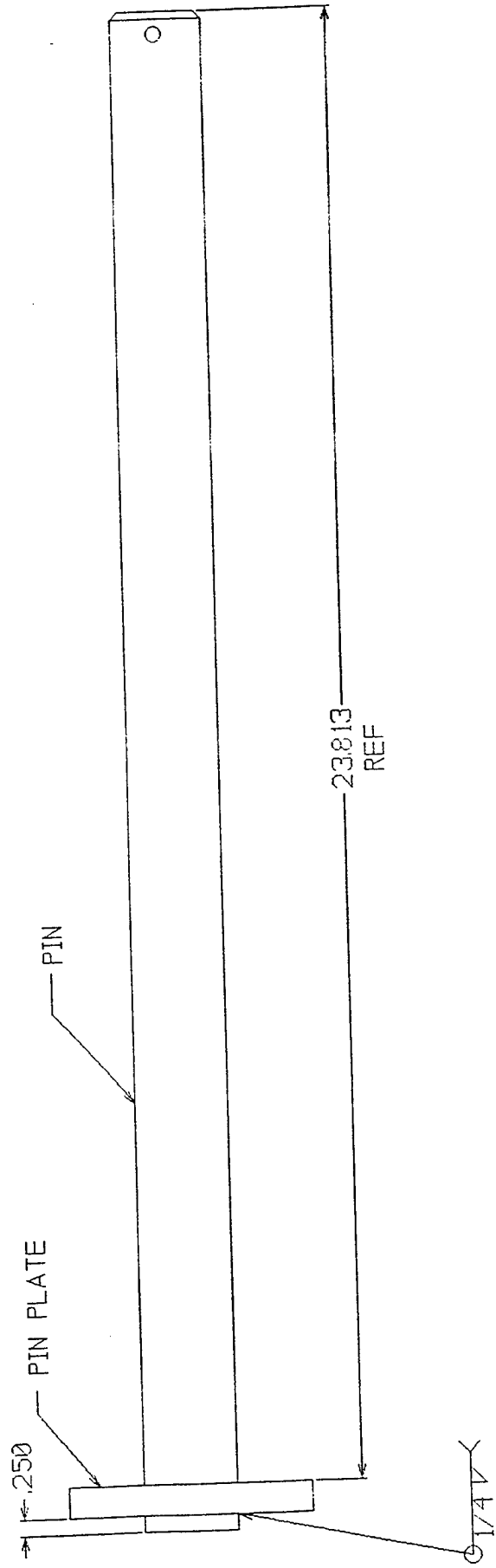

QTY: 2
MAT'L: 2 X 2 X .25 TUBING
END TUBE

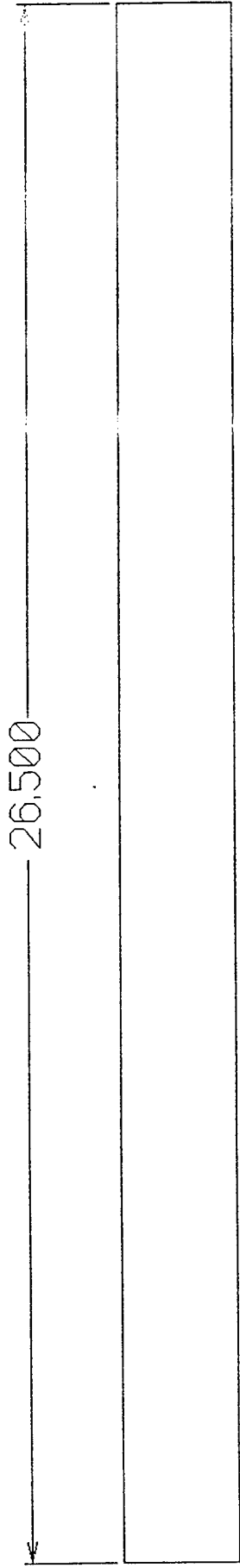

QTY: 10

FOOT

MAT'L: 2 X 2 X .25 TUBING

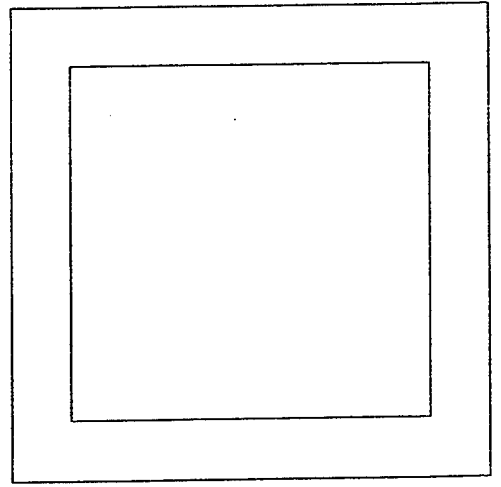
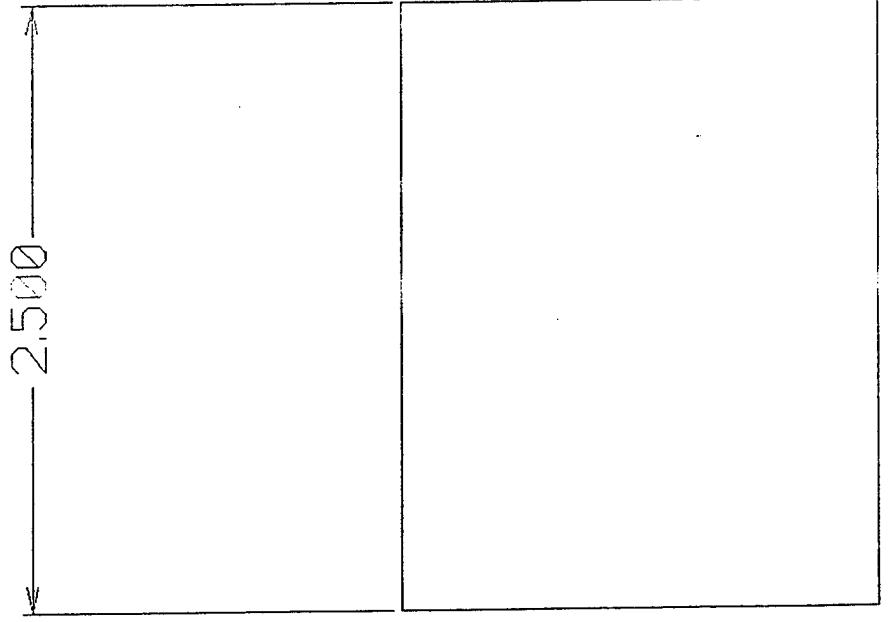

QTY: 2
MATERIAL: 2 X 2 X .25 TUBING
FORK HOOK

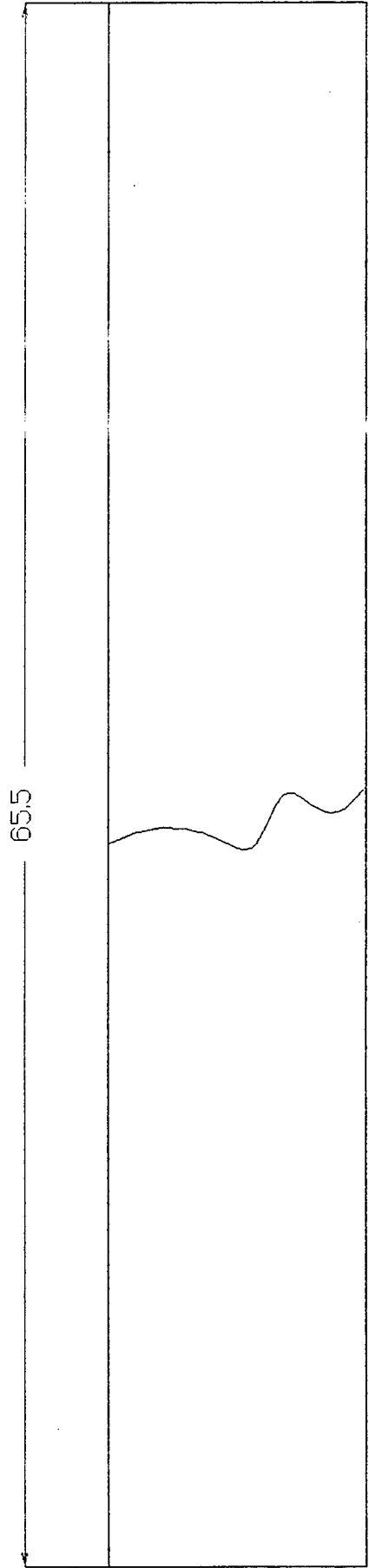

QTY: 3
MATL: 3/4 C.R.S.
LOWER PLATE

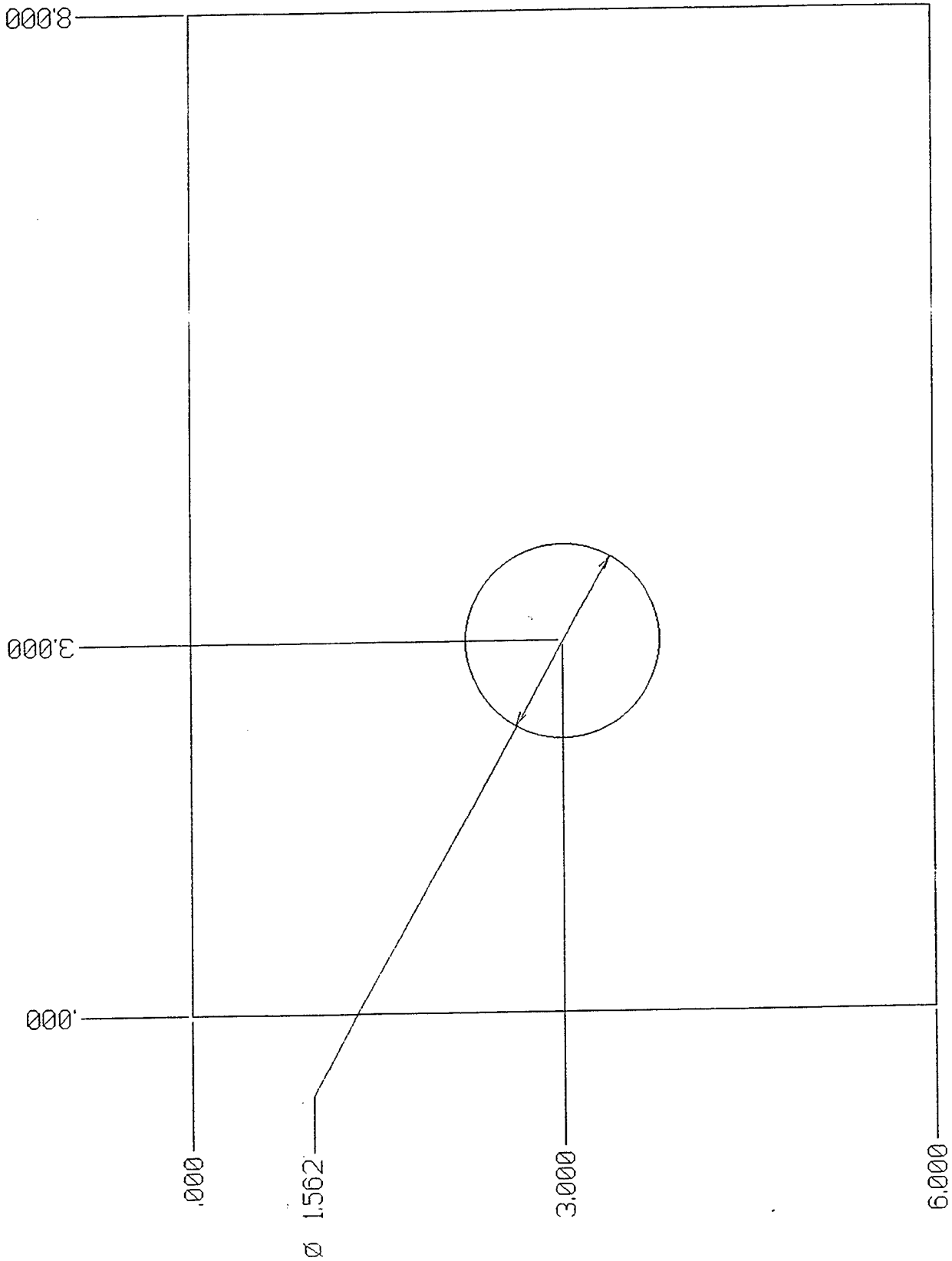

QTY: 2
PIVOT PLATE
MAT'L: 3/4 C.R.S.

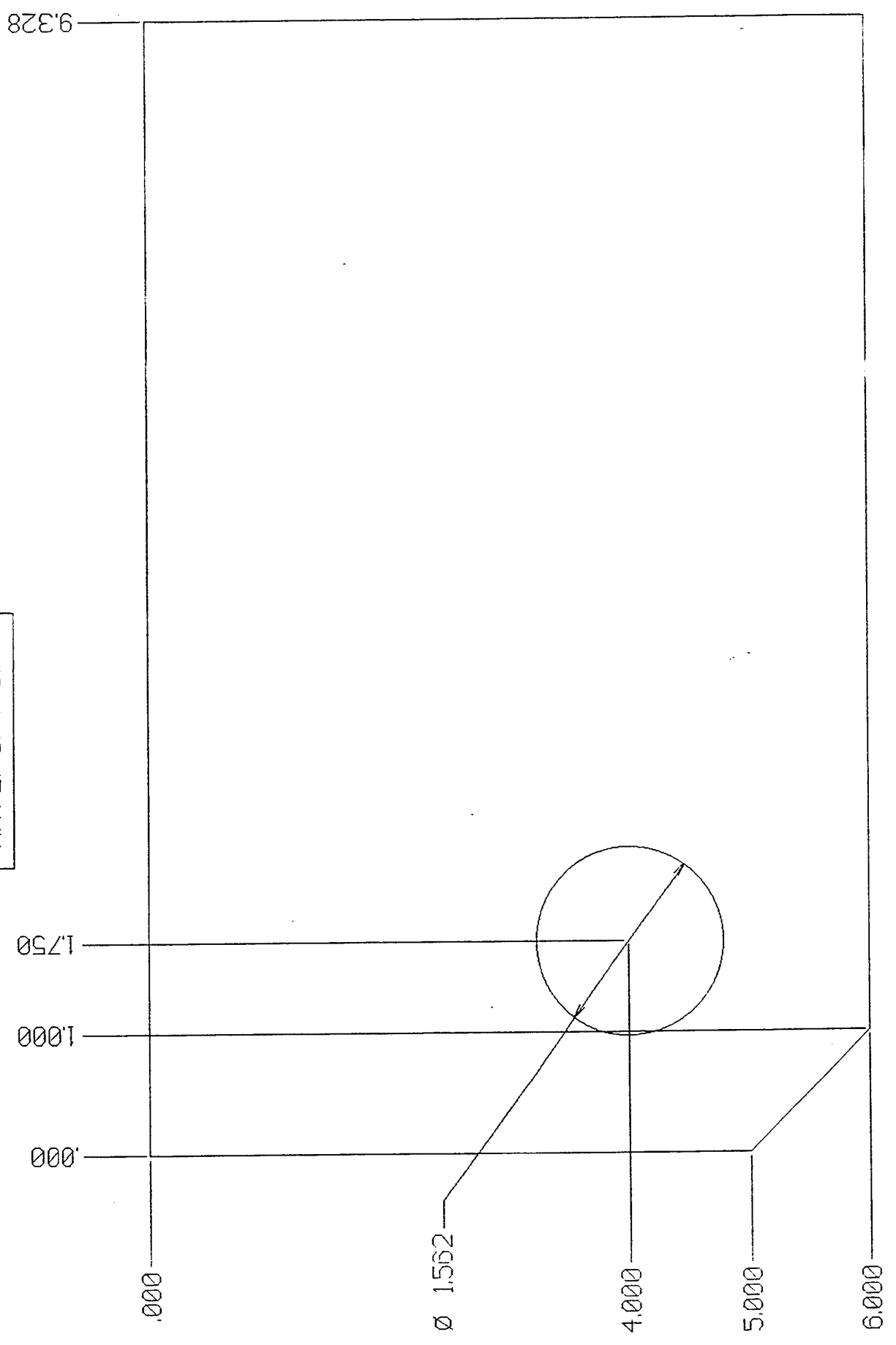

QTY: 1
MATERIAL: 3/4 C.R.S.
TILT ARM

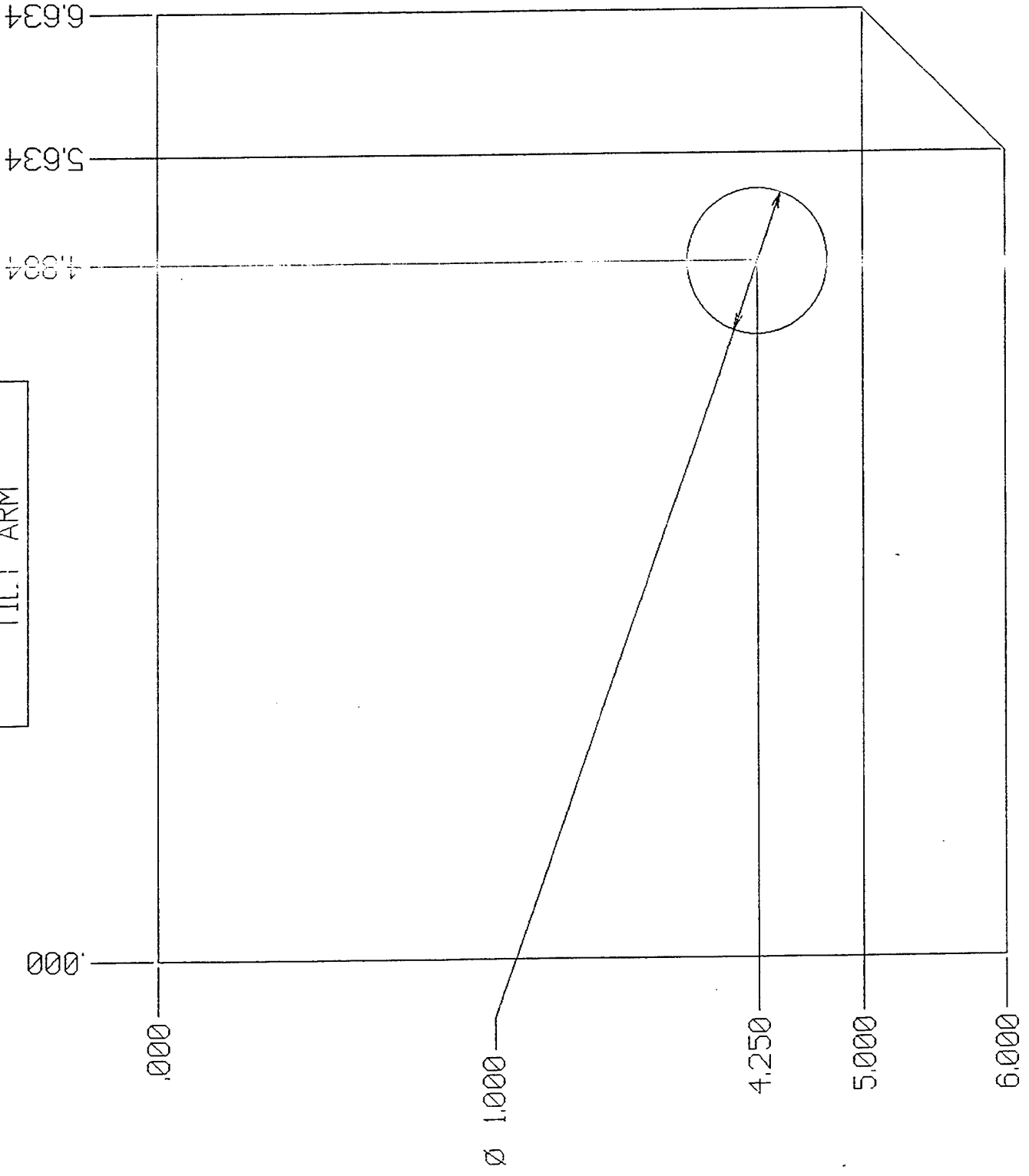

QTY: 1
MATERIAL: 3/4 C.R.S.
TILT BASE

6.000

1.750

1.000

.000

.000

1.000

1.750

Ø 1.000

5.963

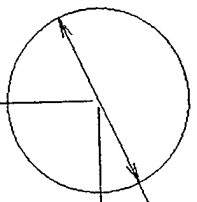

1 MACHINED EDGES

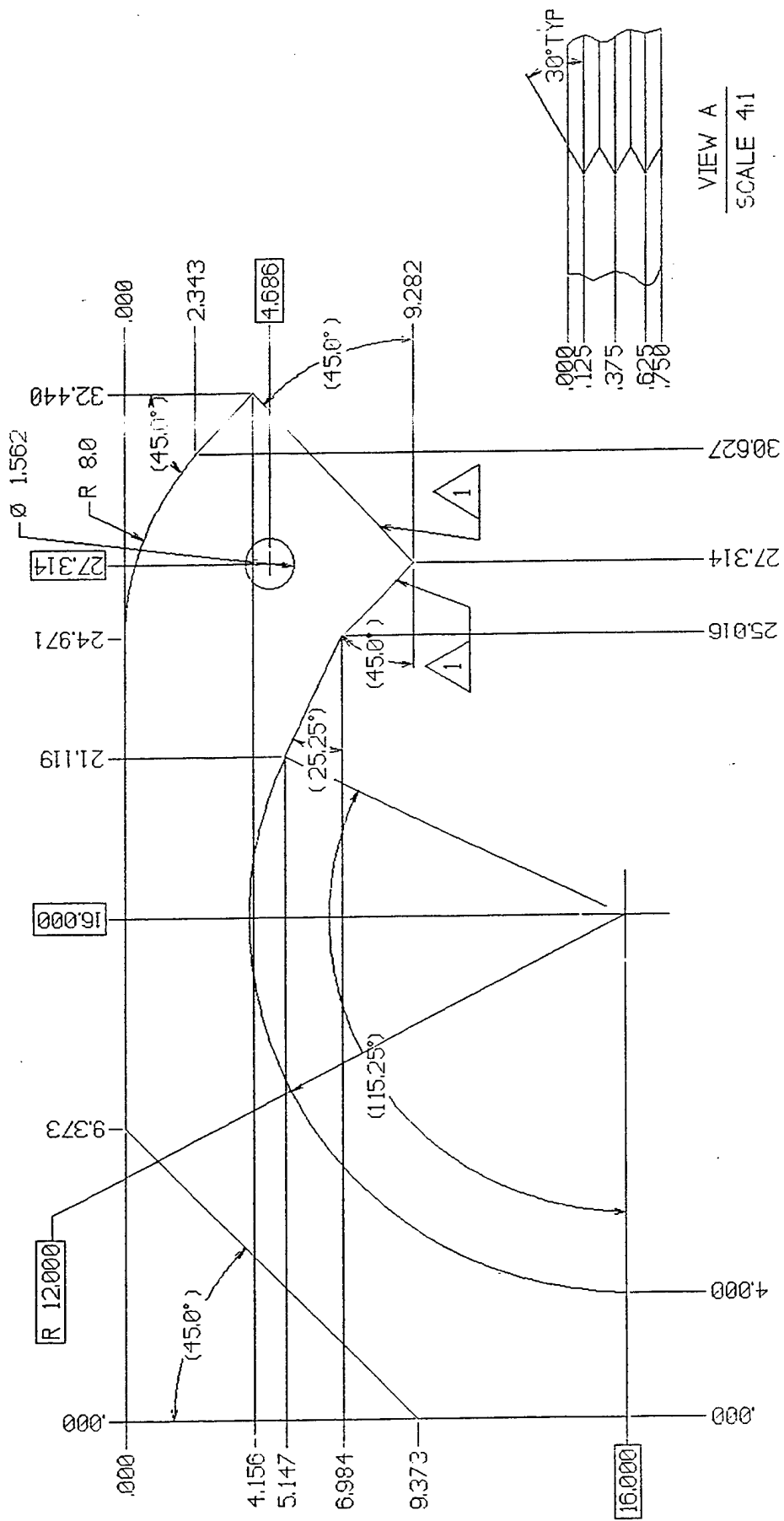

SEE VIEW A

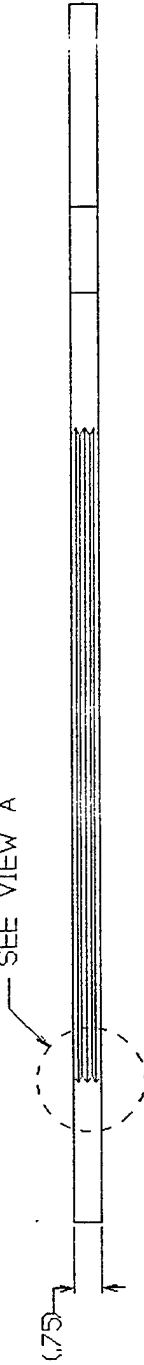

QTY: 4
MATERIAL: 3/4 STEEL PLATE
GRIPPER JAW

QTY: 2
MATERIAL: 3/4 C.R.S
PINCH ARM.

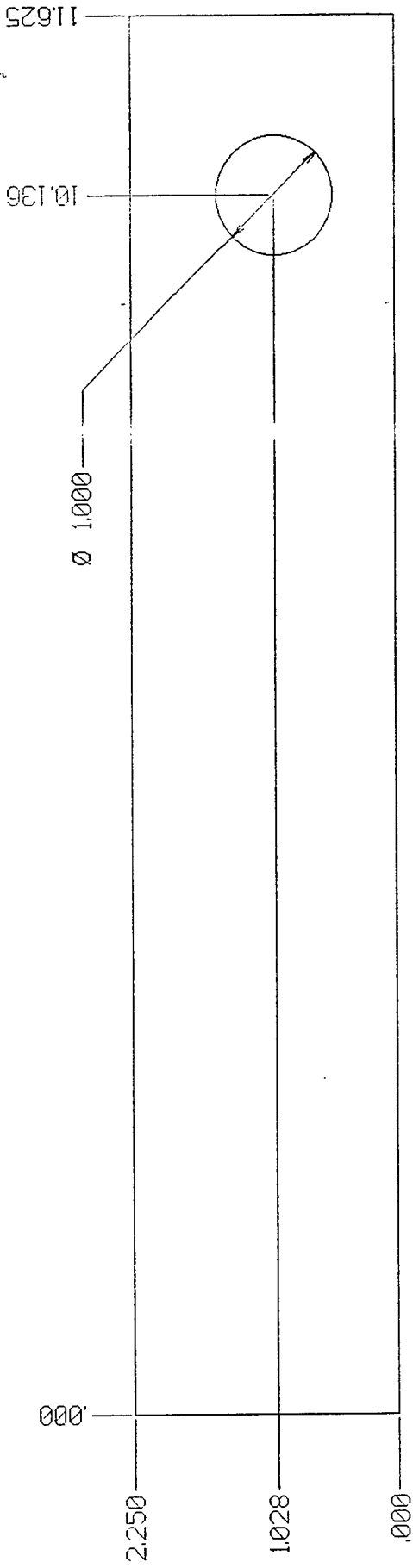

QTY:1
MAT'L: 3/4 C.R.S.
TOP PLATE

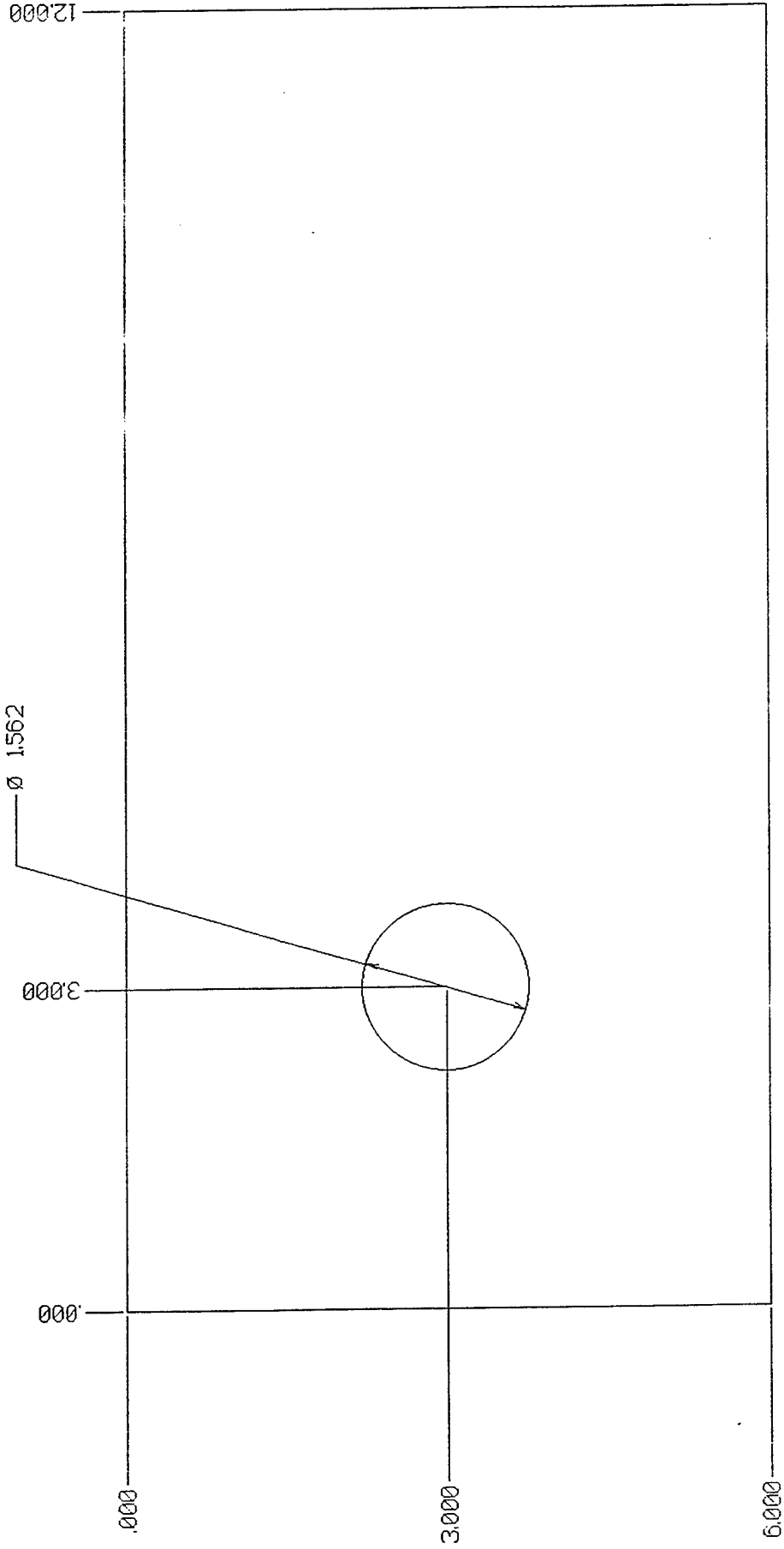

HPC TUBES
4 X 4 X .25 STEEL TUBING

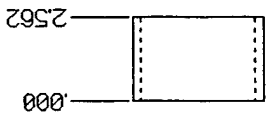

QTY: 3

-1

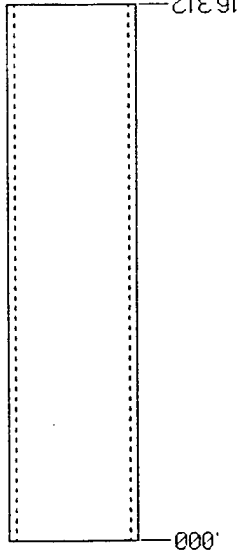

QTY: 1

-2

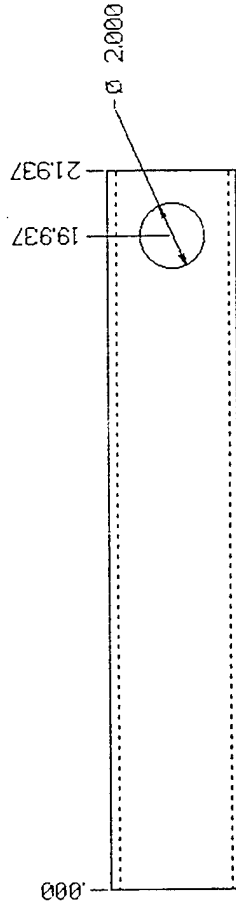

QTY: 1

-3

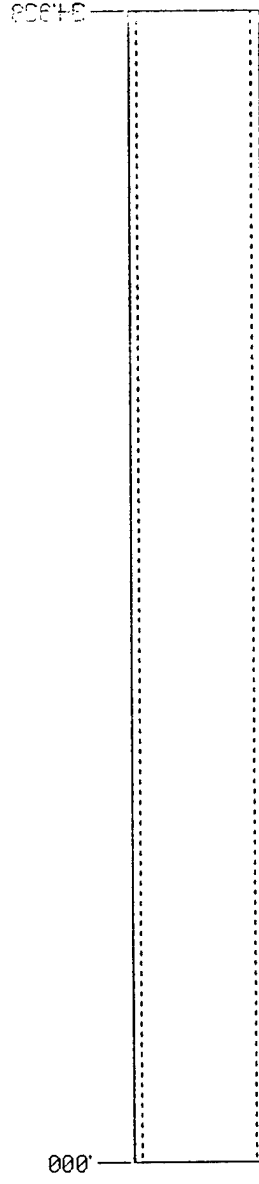

QTY: 1

-4

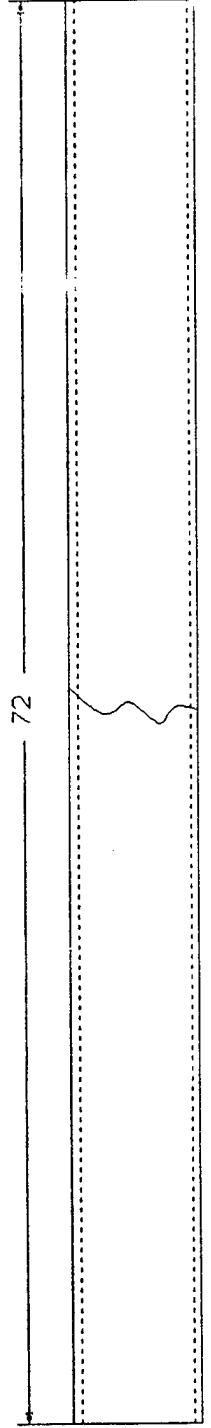

QTY: 2

-5

PUMP MOUNTING PLATE
QTY: 1
MATERIAL: 1/4" STEEL

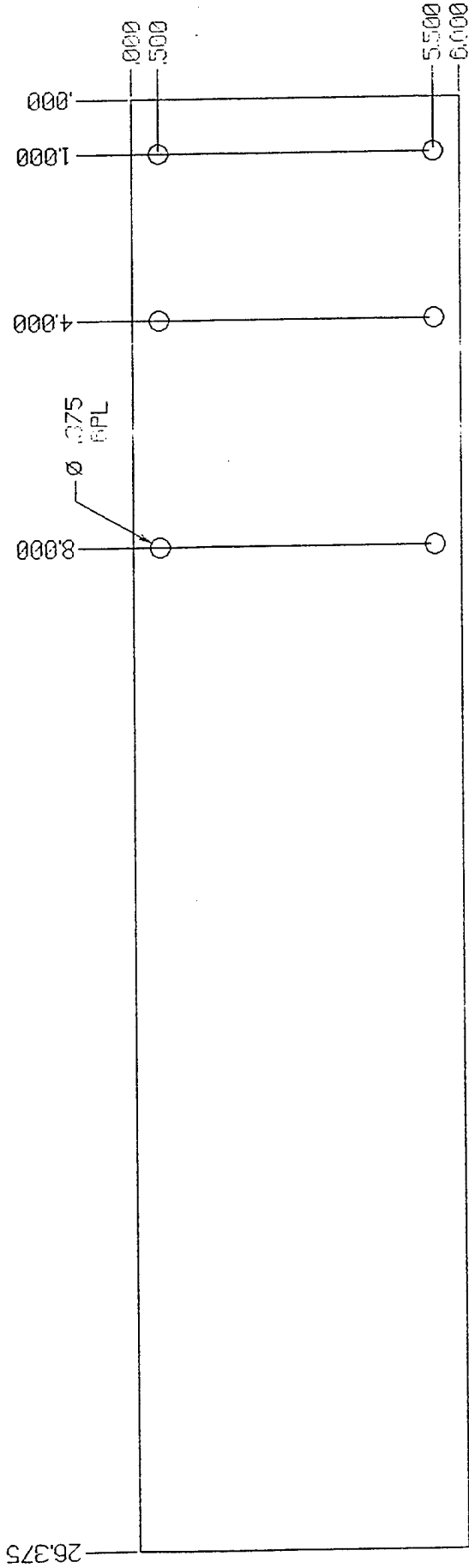

QTY: 6
MATERIAL: .25 STEEL
CAP PLATE

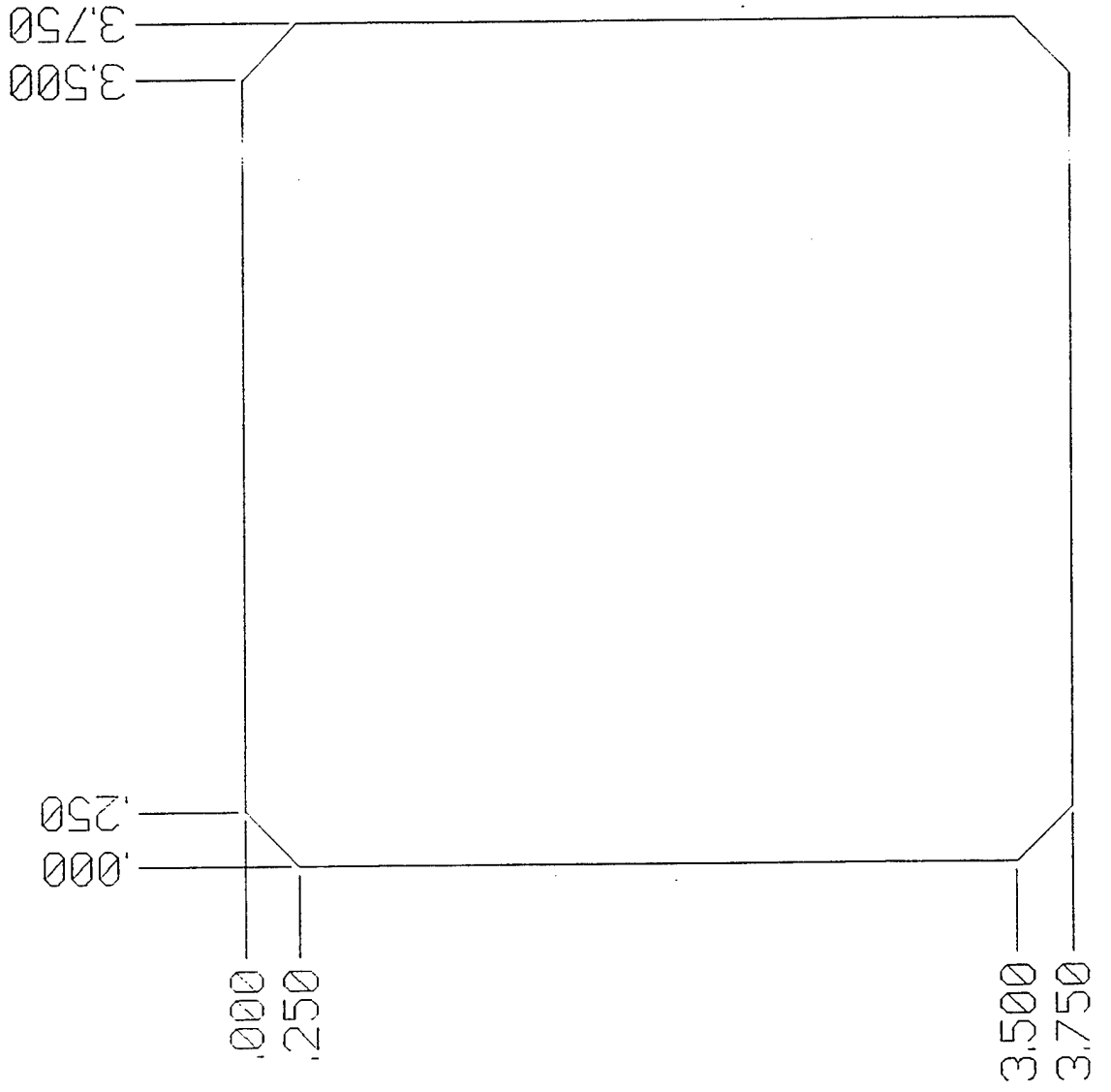

QTY: 2
MAT'L: 1/2 C.R.S.
PIN PLATE

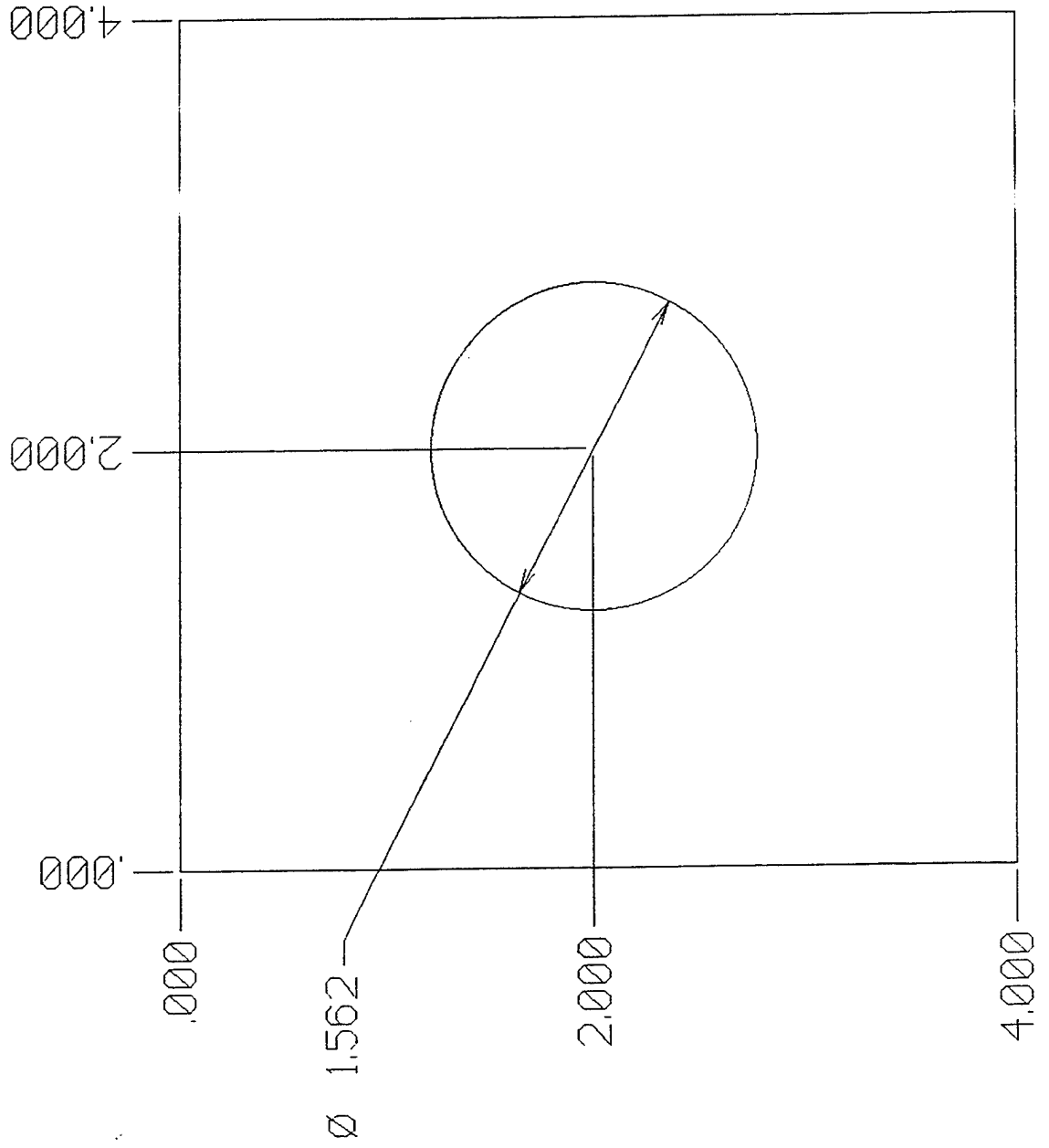

QTY: 1
TILT PIN
MATERIAL: 15 DIA STEEL

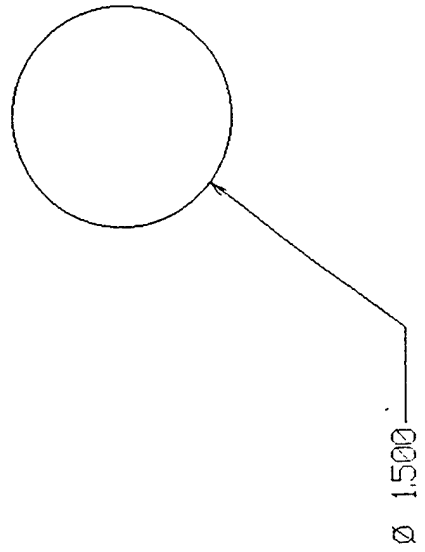
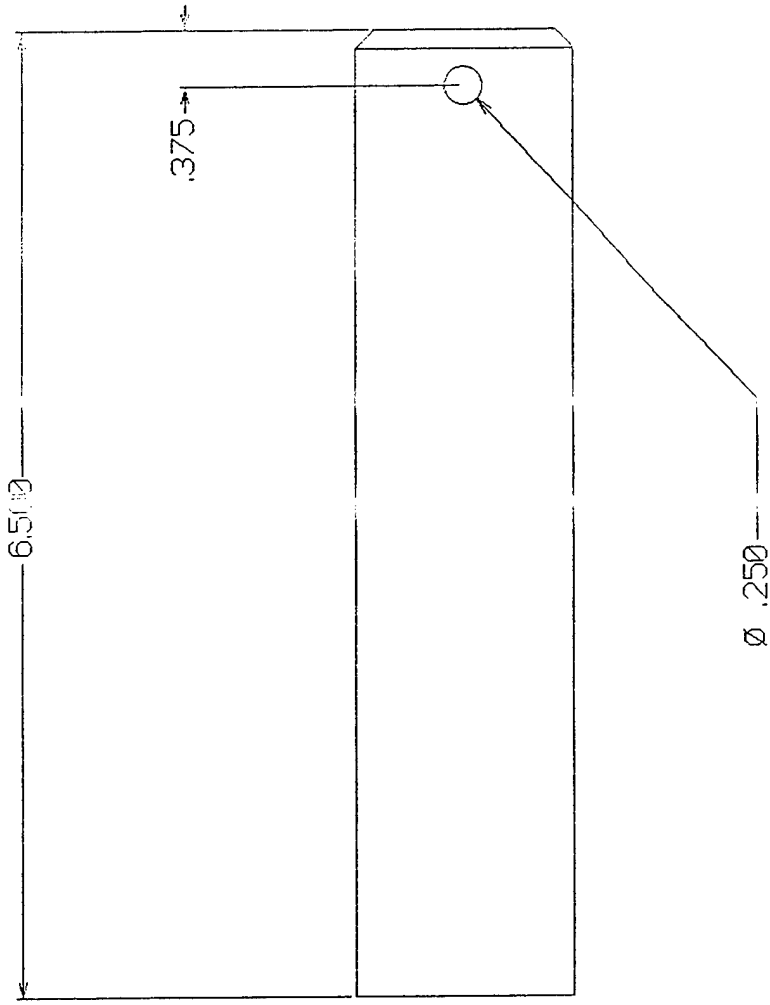

QTY: 1
MATERIAL: 1.5 DIA STEEL
PIN

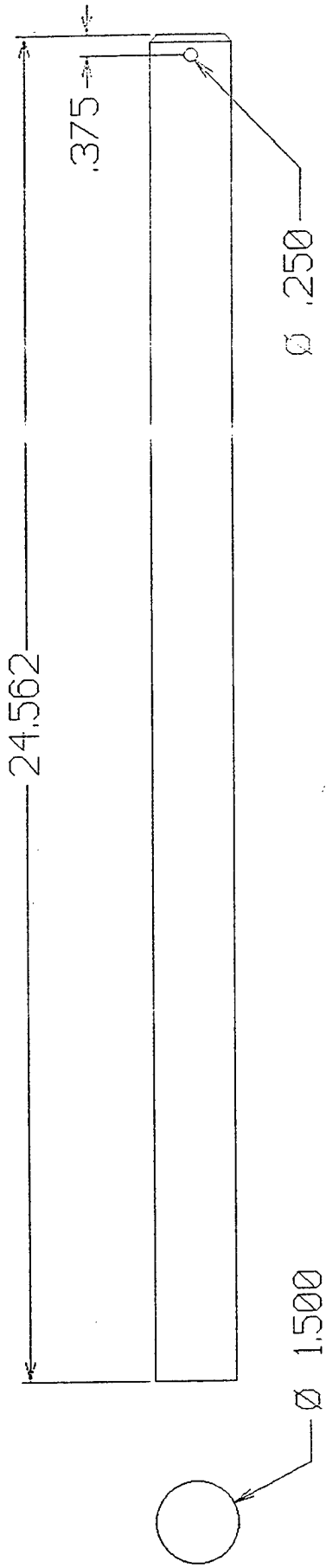

QTY: 1
MAT'L: 2 X 1.5 STEEL TUBE
BOSS TUBE

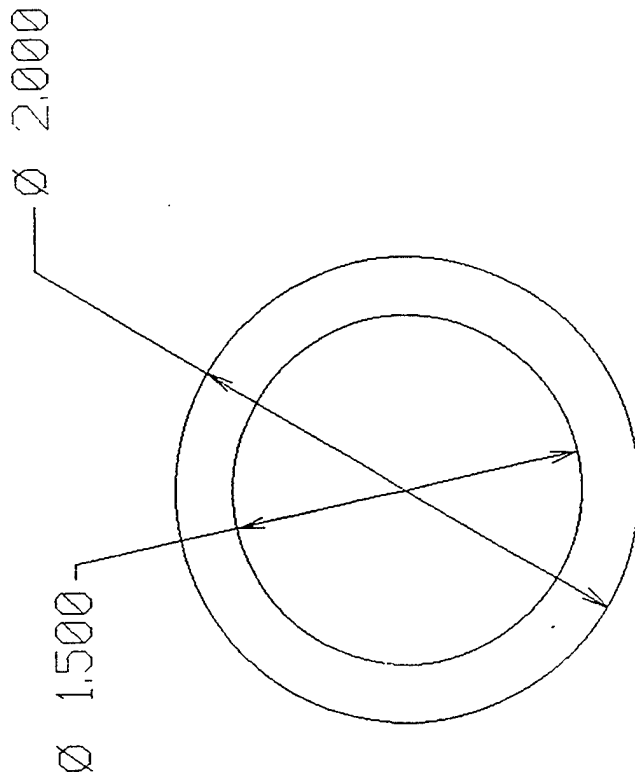
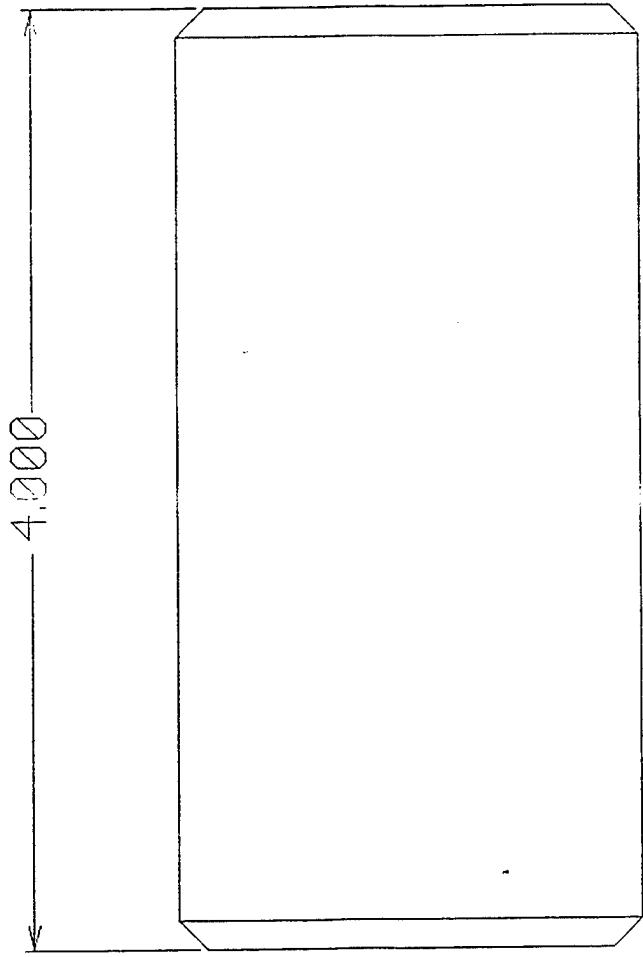

Appendix D- Prototype HPG Calculations

GRIP LOADING & EFFECTS

CALCULATIONS

PAGE 1 OF 2

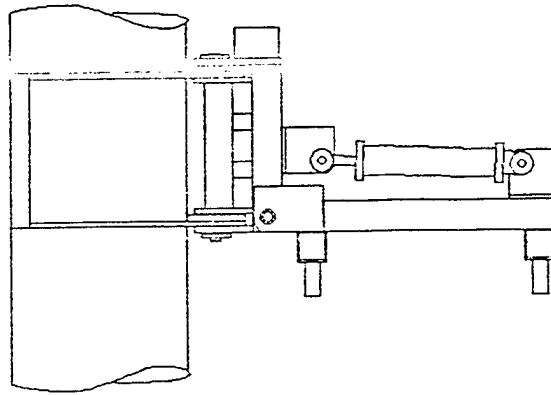
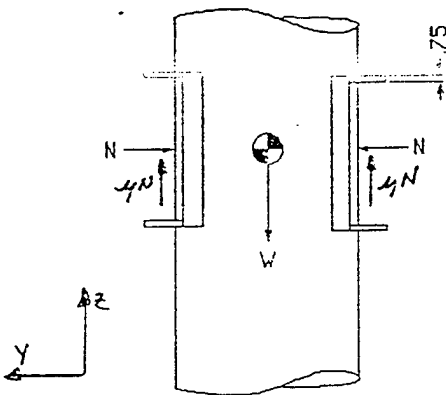
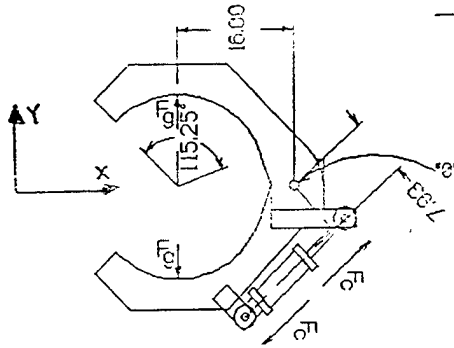

GIVEN:

PILE LENGTH = 10 ft., PILE WEIGHT PER FOOT = 126.3 lb/ft, PILE DIAMETER = 24 in
 3 1/2 IN CYLINDER BORE, $A_H = 9.621 \text{ in}^2$
 TWO GRIP CYLINDERS USED
 JAW THICKNESS = 0.75 IN

ASSUME:

μ , COEFFICIENT OF FRICTION FOR OXIDIZED STEEL ON OXIDIZED STEEL = 0.27

FIND:

- ① MINIMUM GRIP FORCE, $N = F_g$
- ② MINIMUM GRIP CONTACT PRESSURE
- ③ DESIGN GRIP CYLINDER PRESSURE

SOLUTION:

① $W = 126.3 \text{ lb/ft} (10 \text{ ft}) = 1,263 \text{ lb}$

$\sum F_z = 0; N = F_g$

$W = 2\mu N \Rightarrow F_g = \frac{W}{2\mu} = \frac{1,263 \text{ lb}}{2(0.27)}$

$F_g = 2,339 \text{ lb}$

← MINIMUM GRIP FORCE

GRIP LOADINGS & EFFECTS (CONT.)

CALCULATIONS

PAGE 2 OF 2

② $A_J = \text{JAW PRESSURE AREA}$

$$A_J = \left[\pi (24 \text{ IN}) \left(\frac{115.25^\circ}{360^\circ} \right) \right] (0.75 \text{ IN}) = 18.103 \text{ IN}^2$$

GRIP FORCE DISTRIBUTED OVER 2 JAWS PER SIDE OF GRIPPER.

$P_{\text{JAW}} = \text{MINIMUM GRIP PRESSURE ON PILE}$

$$P_{\text{JAW}} = \frac{F_G}{2A_J} = \frac{2,339 \text{ lb}}{2(18.103 \text{ IN}^2)}$$

$$P_{\text{JAW}} = 64.6 \text{ lb/IN}^2$$

← MINIMUM GRIP CONTACT PRESSURE

③ $\sum M_0 = 0;$

$$2F_g (16 \text{ IN}) = 2F_c (7.93 \text{ IN})$$

$$F_c = \frac{2F_g (16 \text{ IN})}{2(7.93 \text{ IN})} = \frac{2,339 \text{ lb} (16 \text{ IN})}{7.93 \text{ IN}}$$

$$F_c = 4,719 \text{ lb}$$

← CYLINDER FORCE, F_c

MINIMUM GRIP PRESSURE

$$P_{\text{MIN}} = \frac{F_c}{2 \text{ CYLINDERS } (A_H)}$$

$$P_{\text{MIN}} = \frac{4,719 \text{ lb}}{2(9.621 \text{ IN}^2)}$$

$$P_{\text{MIN}} = 245 \text{ lb/IN}^2$$

DESIGN PRESSURE: USE MINIMUM SAFETY FACTOR = 2

$$P_{\text{GRIP DESIGN}} = 2(245 \text{ lb/IN}^2)$$

$$P_{\text{GRIP DESIGN}} = 490 \text{ lb/IN}^2$$

← DESIGN GRIP CYLINDER PRESSURE

JAW OPENING RESISTANCE

CALCULATIONS

PAGE 1 OF 1

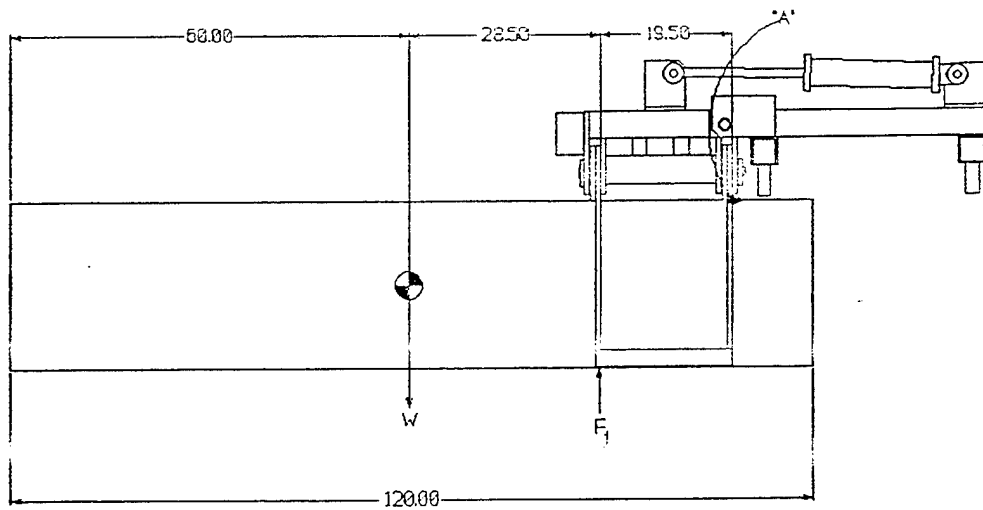
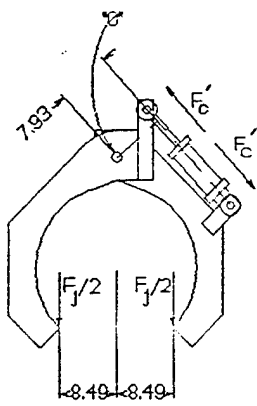

GIVEN:

$$W = 1,263 \text{ lb}$$

$$F_c = 4,719 \text{ lb}$$

ASSUME: WORST CASE

PILE PREVENTED FROM DROPPING BY F_j ACTING ONLY THE EXTREME JAW EDGES

FIND:

FORCE EXERTED ON CYLINDER DUE TO THIS LOADING CONDITION

SOLUTION:

$$\sum M_A = 0;$$

$$W (48 \text{ in}) = F_j (19.5 \text{ in})$$

$$F_j = \frac{1,263 \text{ lb} (48 \text{ in})}{19.5 \text{ in}}$$

$$F_j = 3,109 \text{ lb}$$

LOAD ON JAWS

$$\sum M_o = 0;$$

$$2 \left(\frac{F_j}{2} \right) (8.49 \text{ in}) = 2 F_c' (7.93 \text{ in})$$

$$F_c' = \frac{F_j (8.49 \text{ in})}{2 (7.93 \text{ in})}$$

$$F_c' = 1,664 \text{ lb}$$

LOAD ON GRIP CYLINDER

$$\text{SAFETY MARGIN} = \frac{F_c}{F_c'} = \frac{4,719 \text{ lb}}{1,664 \text{ lb}} = \underline{\underline{2.83}}$$

S.M.

TILT LOADING & EFFECTS

CALCULATIONS

PAGE 1 OF 1

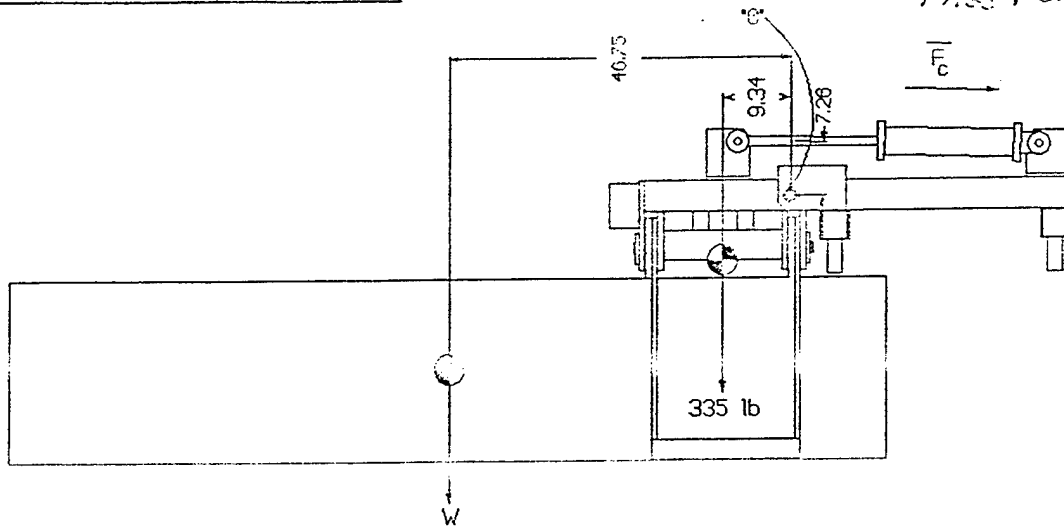

GIVEN:

$W = 1263 \text{ lb}$

OVERHUNG WEIGHT OF HPG = 335 lb.

3/2 IN BORE CYLINDER X 1/4 ROD DIAMETER AREA, $A_H = 8.394 \text{ in}^2$

FIND:

- ① FORCE ON TILT CYLINDER, \bar{F}_c
- ② DESIGN TILT CYLINDER PRESSURE

SOLUTION:

① $\sum M_o = 0;$

$W(46.75 \text{ in}) + 335 \text{ lb}(9.34 \text{ in}) = \bar{F}_c(7.26 \text{ in})$

$$\bar{F}_c = \frac{(1263 \text{ lb})(46.75 \text{ in}) + (335 \text{ lb})(9.34 \text{ in})}{7.26 \text{ in}}$$

$$\bar{F}_c = 8,564 \text{ lb}$$

TILT CYLINDER FORCE, \bar{F}_c

②

$$P'_{MIN} = \frac{\bar{F}_c}{A_H}$$

$$P'_{MIN} = \frac{8,564 \text{ lb}}{8.394 \text{ in}^2}$$

$$P'_{MIN} = 1,020 \text{ lb/in}^2$$

DESIGN PRESSURE: USE MINIMUM SAFETY FACTOR = 2

$$P_{TILT \text{ DESIGN}} = 2(1,020 \text{ lb/in}^2)$$

$$P_{TILT \text{ DESIGN}} = 2,040 \text{ lb/in}^2$$

DESIGN TILT CYLINDER PRESSURE

TILT PIN CAPACITY

CALCULATIONS

PAGE 1 OF 1

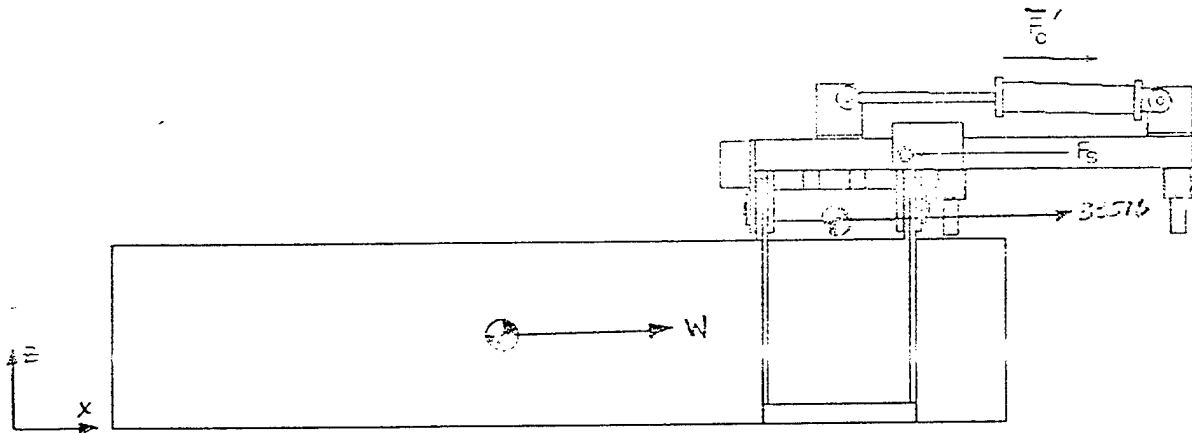

GIVEN:

PIN DIAMETER = 1 1/2 IN, A_S = 1.767 IN², DOUBLE SHEAR.

MATERIAL AISI STEEL, S_S = 39,000 PSI

W = 1263 lb

OVERHUNG WEIGHT OF HPG = 335 lb

F_C' = 2(F_C) = 17,128 lb [TILT CYLINDER FORCE TIMES MINIMUM SAFETY FACTOR OF 2]

ASSUME: WORST CASE

1g - X DIRECTION ACCELERATION WHILE TILTING

F_C, W & OVERHUNG WEIGHT ACT ALONG X-AXIS

FIND:

COMBINED SHEAR STRESS ON TILT PIN

SOLUTION:

$$\sum F_x = 0;$$

$$F_S = F_C' + W + 335 \text{ lb}$$

$$F_S = 18,726 \text{ lb}$$

$$S_p = \frac{F_S}{2A_s}$$

$$S_p = \frac{18,726 \text{ lb}}{2(1.767 \text{ in}^2)}$$

$$S_p = 5,299 \text{ psi}$$

SHEAR STRESS

TILT PIN, S_p

$$\text{SAFETY MARGIN} = \frac{S_s}{S_p} = \frac{39,000 \text{ lb/in}^2}{5,299 \text{ lb/in}^2} = 7.36 \triangle$$

S.M.

TILT CYLINDER INTERFACE

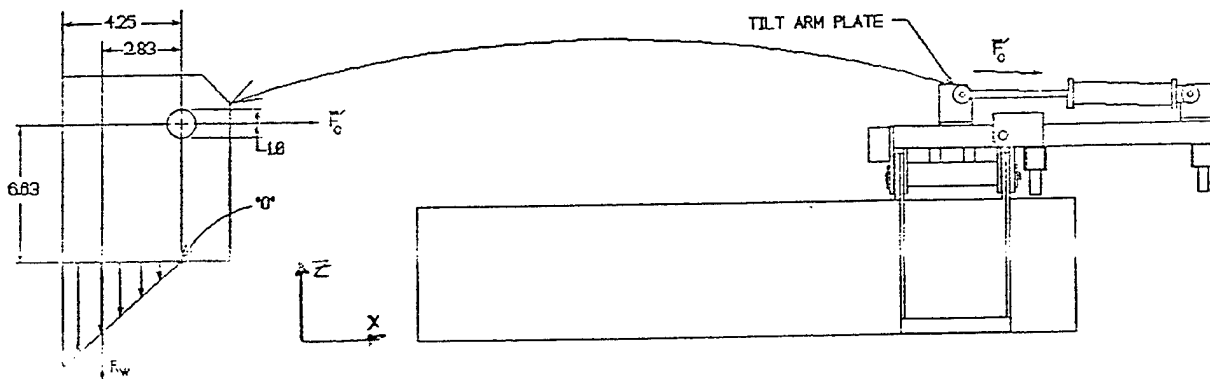

GIVEN:

- PLATE THICKNESS, $t = 0.75$ IN
- FULL PENETRATION $1/4$ IN FILLET WELD
- PLATE MATERIAL 1018, S_b $\text{yield} = 65,000$ lb/in²
- FILLER MATERIAL, STENSILE, $S_{TS} = 70,000$ lb/in²
- SMERAL, $S_{SS} = 47,000$ lb/in²
- TILT ARM PLATE HAS SMALLEST WELD AREA ON HPG
- $F_c = 17,128$ lb
- ASSUME: WORST CASE

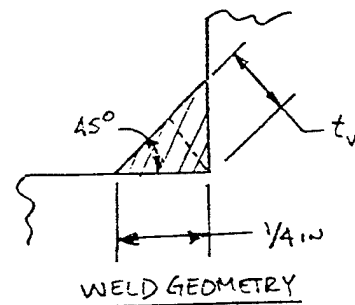

- NEGLECT WELD AREA TO RIGHT OF POINT "O"
- 50% WELD EFFICIENCY
- F_c' ACTS ALONG X-AXIS

FIND:

- ① STRENGTH OF TILT ARM PLATE WELD DUE TO COMBINED LOADING
- ② BEARING STRESS IN TILT ARM PLATE

SOLUTION:

① EFFECTIVE WELD AREA, $A_w = [2(4.25 \text{ in}) + (1.75)] t_w$, $t_w = (1.25 \text{ in}) \sin(45^\circ) = 0.18 \text{ in}$
 $A_w = (9.25 \text{ in})(0.18 \text{ in}) = 1.665 \text{ in}^2$

PRINCIPAL SHEAR STRESS, $S'_s = \frac{F_c'}{A_w} = \frac{17,128 \text{ lb}}{1.665 \text{ in}^2}$

$S'_s = 10,287 \text{ lb/in}^2$ ← PRINCIPAL SHEAR STRESS

PRINCIPAL NORMAL STRESS, $S'_n = \frac{R_w}{A_w}$

$$\sum M_0 = 0;$$

$$R_W (2.83 \text{ IN}) = \bar{F}'_C (6.63 \text{ IN})$$

$$R_W = \frac{\bar{F}'_C (6.63 \text{ IN})}{2.83 \text{ IN}} = \frac{(17,128 \text{ LB})(6.63 \text{ IN})}{2.83 \text{ IN}}$$

$$R_W = 40,127 \text{ LB}$$

$$S'_N = \frac{P}{A_W} = \frac{40,127 \text{ LB}}{1.665 \text{ IN}^2}$$

$$S'_N = 24,100 \text{ LB/IN}^2$$

COMBINED LOADING:

$$S_N = \left(\frac{S'_N}{2} \right) \pm \sqrt{\left(\frac{S'_N}{2} \right)^2 + (S'_S)^2}, \text{ MAXIMUM TENSILE STRESS}$$

$$S_S = \pm \sqrt{\left(\frac{S'_N}{2} \right)^2 + (S'_S)^2}, \text{ MAXIMUM SHEAR STRESS}$$

$$S_N = \left(\frac{24,100 \text{ LB/IN}^2}{2} \right) \pm \sqrt{\left(\frac{24,100 \text{ LB/IN}^2}{2} \right)^2 + (10,287 \text{ LB/IN}^2)^2}$$

$$S_N = (12,050 \text{ LB/IN}^2) \pm (15,844 \text{ LB/IN}^2)$$

$$S_N = 27,894 \text{ LB/IN}^2$$

← MAXIMUM TENSILE STRESS, S_N

$$S_S = \pm \sqrt{\left(\frac{24,100 \text{ LB/IN}^2}{2} \right)^2 + (10,287 \text{ LB/IN}^2)^2}$$

$$S_S = 15,844 \text{ LB/IN}^2$$

← MAXIMUM SHEAR STRESS, S_S

SAFETY MARGIN, S.M.

$$S.M._T = \frac{S_{TS}}{S_N} = \frac{70,000 \text{ lb/in}^2}{27,894 \text{ lb/in}^2} = \underline{\underline{2.51}} \leftarrow \text{S.M.}_T$$

$$S.M._S = \frac{S_{SS}}{S_S} = \frac{42,000 \text{ lb/in}^2}{15,844 \text{ lb/in}^2} = \underline{\underline{2.65}} \leftarrow \text{S.M.}_S$$

② BEARING STRESS, $S'_b = \frac{\bar{F}_c'}{A_B}$

BEARING AREA, $A_B = (1.0 \text{ in})(0.75 \text{ in})$

$A_B = 0.75 \text{ in}^2$

$$S'_b = \frac{\bar{F}_c'}{A_B} = \frac{17,128 \text{ lb}}{0.75 \text{ in}^2}$$

$S'_b = 22,837 \text{ lb/in}^2$

← BEARING STRESS, S_b'

SAFETY MARGIN, $S.M._b = \frac{S_b}{S_b'} = \frac{65,000 \text{ lb/in}^2}{22,837 \text{ lb/in}^2} = \underline{\underline{2.85}} \leftarrow \text{S.M.}_b$

•

Appendix E - Model RPPC and HPG Instructions

•

•

•

•

Rapid Pipe Pile Cutter Operation

1. Preliminary Service Hook-Up

- a) Connect air line capable of delivering a minimum of 65 psi @ approximately 5.0 SCFM.
- b) Connect to electrical power 220 VAC, 60 Hz, 3-phase capable of delivering 50 A.

2. RPPC Operation

- a) Ensure electrical power and air connections.
- b) Release the latch and open the clamshell.
- c) Wheel the unit up to the pile, ensuring the contact of the two rear centering studs.
- d) Close the clamshell and latch.
- e) *(Adjust the torch angle for straight or bevel cut if necessary but loosening the clamps holding the torch to the panograph arm. Note: The pile must be plumb for the torch to track properly on the prototype. Check that the torch tracking pin maintains the torch approximately 1/8-3/16" off of the pile. This can be done manually by loosening the wing nut on the knurled knob on the face of the drive unit. Rotate the knob to disengage the drive gear. The drive unit can now be moved around the track manually. Once everything is set, re-engage the drive gear and tighten the wing nut.)*
- f) Set the mode switch to MANUAL and set the direction switch to REVERSE. *(This will ensure that the cut begins at the proper location. This step is not necessary if the unit completes a continuous automatic cycle.)*
- g) Switch the direction switch to PAUSE and the mode switch to OFF.
- h) Attach the magnetic ground to the pile.
- i) Turn Plasma Arc Unit power switch ON and check for proper air pressure.
CAUTION: The torch button on the torch is operational. Do not attempt to adjust the torch angle or make any other adjustments around the torch with the power on. The torch could accidentally be started. Turn the power off.
- j) The Air Check and Lock In switches should be OFF.
- k) Set the speed control on the drive unit for the cut being performed. *(A straight cut on 1/2" pile speed setting is approximately 62. A 30 degree bevel cut speed setting is approximately 50. This may have to be adjusted slightly either up or down depending on the performance. If full penetration is not maintained reduce the speed. If the torch self-extinguishes then increase the speed.)*
- l) Set the mode switch to AUTOMATIC.
- m) When all is ready press START. *(Air will flow through the torch for approximately 2 seconds then the torch will ignite. The torch will pierce for 4 seconds then begin to move forward around the pile. At the end of the cutting cycle, the torch will shut off and reverse direction. Once at the home position the drive unit will shut down.)*
- n) **Press the STOP button at any time during the automatic cutting cycle to turn the torch off and shut the drive unit down. (If STOP is pressed, the torch**

C 3

may be repositioned using the manual controls and automatic cutting restarted at any position. If STOP was pushed on the reverse portion of the cycle, use the manual reverse to return the torch to the home position.)

- o) Once the RPPC completes the automatic cycle, turn the mode switch to the center OFF position.
- p) Turn the power to the Plasma Arc Unit OFF.
- q) Disconnect the magnetic ground.
- r) Open the latch and clamshell and wheel the unit clear. Close the clamshell.

Hydraulic Pile Gripper Operation

1. Set the fork width on the forklift to fit the outer openings on the base of the HPG. *(If the forks will not adjust wide enough to fit the outer openings, make sure that the forks do not extend more than 2 inches beyond the front of the 4" x 4" frame tube. The lower grip cylinder could contact the fork when tilted fully forward. If necessary, use a C-clamp on each fork to set the proper fork engagement.)*
2. Center the forklift in front of the unit and drive the forks into the openings.
3. Connect the safety chain to the fork support structure. *(The hook can be moved to different location on the chain if additional length is needed.)*
4. Attach the control valve to the forklift roll cage.
5. Connect to electrical power to 220 VAC, 60 Hz, single phase. The pump draws approximately 15 amps. **Have another person watch the electrical cord while the forklift is being operated.** *(The Hydraulic Power Unit has a duty cycle of approximately 10 minutes disconnect the power when not in use.)*
6. Maneuver the unit to pile and use the GRIP controls to open or close the jaws and the TILT controls adjust the angle.
7. When gripping a pile, open the jaws completely and drive up to the pile. Using the TILT control adjust the unit so that the apex of the upper and lower jaws contact the pile. Close the GRIP jaws. The unit will self-center around the pile. *(Make sure that each jaw is full contact with the pile. Hold the grip control to CLOSE for one or two seconds until the pressure relief opens {the sound of the pump will change} to provide maximum grip pressure.)*
8. Maneuver the pile as necessary. **NOTE: The HPG prototype is designed to handle a maximum of 10 feet of 24" x 1/2" pile. DO NOT operate the GRIP control while the pile is lifted; THE PILE WILL FALL.**
9. When complete, disconnect electrical power.
10. Disconnect the control valve from the forklift. *(Remember to do this first, otherwise the valve or HPG could be damaged if the forklift is backed away.)*
11. Remove the safety chain.
12. Back away from the HPG.