

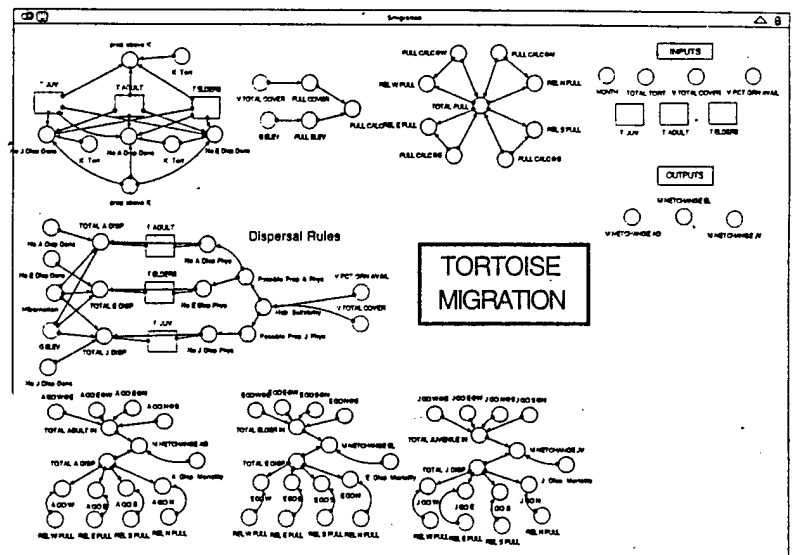

# A Dynamic Simulation Model of the Desert Tortoise (*Gopherus agassizii*) Habitat in the Central Mojave Desert

by  
James Westervelt, Bruce Hannon, Shaun Levi, and Steve Harper



19970828 053

Historically, conscientious land use decisions that preserve complex relationships within ecosystems and among communities living on the landscape emerged only by rigorously testing various land management strategies. Until recently, the most convenient "laboratory" available was the open environment itself. Political and legislative policies have provided incentives to change this costly trial-and-error experimentation. Across the nation, Army and civilian land management offices responsible for the management of natural resources, endangered

species, water quality, aesthetics, and economic productivity of the land, are turning toward ecological modeling for assistance in making decisions.

This report describes the development of a dynamic, spatial, ecological model designed to help manage and protect the endangered desert tortoise living at Fort Irwin, an Army training center in the Mojave Desert. It is a generic prototype of the kind of tool needed to predict potential consequences and the degree of severity that highly disruptive land uses can have on the natural environment.

DTIC QUALITY INSPECTED 4

The contents of this report are not to be used for advertising, publication, or promotional purposes. Citation of trade names does not constitute an official endorsement or approval of the use of such commercial products. The findings of this report are not to be construed as an official Department of the Army position, unless so designated by other authorized documents.

***DESTROY THIS REPORT WHEN IT IS NO LONGER NEEDED***

***DO NOT RETURN IT TO THE ORIGINATOR***

## USER EVALUATION OF REPORT

REFERENCE: USACERL Technical Report 97/102, *A Dynamic Simulation Model of Desert Tortoise (Gopherus agassizii) Habitat in the Central Mojave Desert*

Please take a few minutes to answer the questions below, tear out this sheet, and return it to USACERL. As user of this report, your customer comments will provide USACERL with information essential for improving future reports.

1. Does this report satisfy a need? (Comment on purpose, related project, or other area of interest for which report will be used.)

---

---

---

2. How, specifically, is the report being used? (Information source, design data or procedure, management procedure, source of ideas, etc.)

---

---

3. Has the information in this report led to any quantitative savings as far as manhours/contract dollars saved, operating costs avoided, efficiencies achieved, etc.? If so, please elaborate.

---

---

4. What is your evaluation of this report in the following areas?

a. Presentation: \_\_\_\_\_

b. Completeness: \_\_\_\_\_

c. Easy to Understand: \_\_\_\_\_

d. Easy to Implement: \_\_\_\_\_

e. Adequate Reference Material: \_\_\_\_\_

f. Relates to Area of Interest: \_\_\_\_\_

g. Did the report meet your expectations? \_\_\_\_\_

h. Does the report raise unanswered questions? \_\_\_\_\_

i. General Comments. (Indicate what you think should be changed to make this report and future reports of this type more responsive to your needs, more usable, improve readability, etc.)

---

---

---

---

---

---

---

---

5. If you would like to be contacted by the personnel who prepared this report to raise specific questions or discuss the topic, please fill in the following information.

Name: \_\_\_\_\_

Telephone Number: \_\_\_\_\_

Organization Address: \_\_\_\_\_

\_\_\_\_\_

\_\_\_\_\_

6. Please mail the completed form to:

Department of the Army  
CONSTRUCTION ENGINEERING RESEARCH LABORATORIES  
ATTN: CECER-TR-I  
P.O. Box 9005  
Champaign, IL 61826-9005

# REPORT DOCUMENTATION PAGE

Form Approved  
OMB No. 0704-0188

Public reporting burden for this collection of information is estimated to average 1 hour per response, including the time for reviewing instructions, searching existing data sources, gathering and maintaining the data needed, and completing and reviewing the collection of information. Send comments regarding this burden estimate or any other aspect of this collection of information, including suggestions for reducing this burden, to Washington Headquarters Services, Directorate for Information Operations and Reports, 1215 Jefferson Davis Highway, Suite 1204, Arlington, VA 22202-4302, and to the Office of Management and Budget, Paperwork Reduction Project (0704-0188), Washington, DC 20503.

1. AGENCY USE ONLY (Leave Blank)		2. REPORT DATE July 1997	3. REPORT TYPE AND DATES COVERED Final	
4. TITLE AND SUBTITLE A Dynamic Simulation Model of Desert Tortoise ( <i>Gopherus agassizii</i> ) Habitat in the Central Mojave Desert			5. FUNDING NUMBERS BT25 LL-IA6	
6. AUTHOR(S) James Westervelt, Bruce Hannon, Shaun Levi, Steven Harper				
7. PERFORMING ORGANIZATION NAME(S) AND ADDRESS(ES) U.S. Army Construction Engineering Research Laboratories (USACERL) P.O. Box 9005 Champaign, IL 61826-9005			8. PERFORMING ORGANIZATION REPORT NUMBER  TR 97/102	
9. SPONSORING / MONITORING AGENCY NAME(S) AND ADDRESS(ES) HQ USACE ATTN: CERD-M 20 Massachusetts Ave. N.W. Washington, DC 20314-1000			10. SPONSORING / MONITORING AGENCY REPORT NUMBER	
11. SUPPLEMENTARY NOTES Copies are available from the National Technical Information Service, 5285 Port Royal Road, Springfield, VA 22161.				
12a. DISTRIBUTION / AVAILABILITY STATEMENT  Approved for public release; distribution is unlimited.			12b. DISTRIBUTION CODE	
13. ABSTRACT (Maximum 200 words)  Historically, conscientious land use decisions that preserve complex relationships within ecosystems and among communities living on the landscape emerged only by rigorously testing various land management strategies. Until recently, the most convenient "laboratory" available was the open environment itself. Political and legislative policies have provided incentives to change this costly trial-and-error experimentation. Across the nation, Army and civilian land management offices responsible for the management of natural resources, endangered species, water quality, aesthetics, and economic productivity of the land, are turning toward ecological modeling for assistance in making decisions.  This report describes the development of a dynamic, spatial, ecological model designed to help manage and protect the endangered desert tortoise living at Fort Irwin, an Army training center in the Mojave Desert. It is a generic prototype of the kind of tool needed to predict potential consequences and the degree of severity that highly disruptive land uses can have on the natural environment.				
14. SUBJECT TERMS Desert Tortoise Simulation modeling Ft. Irwin, CA			15. NUMBER OF PAGES 78	
			16. PRICE CODE	
17. SECURITY CLASSIFICATION OF REPORT Unclassified	18. SECURITY CLASSIFICATION OF THIS PAGE Unclassified	19. SECURITY CLASSIFICATION OF ABSTRACT Unclassified	20. LIMITATION OF ABSTRACT SAR	

## Foreword

This study was conducted for Headquarters, U.S. Army Corps of Engineers, Director of Research and Development (DRD), under Project 40161102BT25, "Environmental Research - Corps of Engineers"; Work Unit LL-IA6, "Fundamentals of Dynamic Landform and Ecological Modeling." The technical monitor was Tom Hart.

The work was performed by the Natural Resource Assessment and Management Division (LL-N) of the Land Management Laboratory (LL), U.S. Army Construction Engineering Research Laboratories (USACERL). The USACERL principal investigator was Dr. James Westervelt. Dr. Bruce Hannon is a Jubilee professor in the Department of Geography at the University of Illinois. Dr. Steve Harper is a post-doctoral researcher working at USACERL through Oak Ridge Affiliated Universities. Shaun Levi was a graduate student in the Department of Geography at the U of I and employed by USACERL through that department. Other students and faculty members that participated in this research are listed in the Approach section. Dr. David J. Tazik is Acting Chief, CECER-LL-N; Dr. William D. Severinghaus is Operations Chief, CECER-LL. The USACERL technical editor was Gloria J. Wienke, Technical Resources.

Dr. Michael J. O'Connor is Technical Director of USACERL.

# Contents

<b>SF 298</b> .....	2
<b>Foreword</b> .....	3
<b>List of Figures and Table</b> .....	5
<b>1 Introduction</b> .....	7
Background .....	7
Objective .....	8
Approach .....	9
<b>2 Pre-model Development Steps</b> .....	11
Identify Operational Boundary Conditions .....	11
Time and Space Decisions .....	12
<b>3 The Desert Tortoise Model</b> .....	16
Climate Submodel .....	16
Vegetation Submodel .....	28
Desert Tortoise Submodel .....	34
Tortoise Dispersal Submodel .....	43
<b>4 Results and Future Research</b> .....	48
The Proposed Sensitivity Analysis Approach .....	49
Recommended Strategy .....	49
<b>5 Summary</b> .....	52
<b>References</b> .....	54
<b>Appendix: Full Model</b> .....	59
<b>Distribution</b> .....	

## List of Figures and Table

### Figures

1	The climate submodel .....	17
2	The precipitation model .....	18
3	The temperature module .....	19
4	The temperature modification process .....	21
5	The water balance process .....	22
6	The soil moisture module .....	28
7	The vegetation submodel .....	29
8	The vegetation carrying capacity module .....	30
9	The plant succession module .....	32
10	The green and brown vegetation module .....	33
11	The tortoise submodel .....	35
12	The eggs cohort of the tortoise submodel .....	36
13	The hatchling cohort of the tortoise submodel .....	39
14	The juvenile cohort of the tortoise submodel .....	40
15	The adult cohort of the tortoise submodel .....	42
16	The elders cohort of the tortoise submodel .....	43
17	The dispersal submodel .....	44

---

18	Tortoise dispersal rules .....	46
19	Projected tortoise density .....	48
Table		
1	Sample Sensitivity Analysis Output .....	51

# 1 Introduction

## Background

Instead of perceiving the landscape as several independent parcels, managers must deal with the entire landscape and begin to anticipate how activities in one area might affect the physical and biotic properties of adjoining areas (Turner et al. 1995).

Land management offices responsible for the management of natural resources, endangered species, water quality, aesthetics, and economic productivity of the land, are turning toward dynamic, spatial, ecological modeling for assistance in making decisions. However, informed, conscientious land use decisions that preserve complex relationships within ecosystems and among communities living on the landscape emerge only by rigorously testing various land management strategies. Until recently, the only "laboratory" available for systems analysis was the open environment itself. Development in computer technology and modeling approaches now offer effective research alternatives. Consequently, local, state, and Federal land management offices are beginning to develop dynamic, spatial, ecological models as tools to help design, integrate, and test varied land management strategies across space and time. Typically, these models are discipline-specific, such as hydrology, ecology, economics, human activity, biodiversity, and engineering.

The research described in this report is part of a larger program being conducted at the Construction Engineering Research Laboratories (USACERL) in Champaign, IL. The program seeks to develop a foundation for collaborative, interdisciplinary land simulation models in support of balancing military training with requirements to manage the natural systems for sustainability. The primary purpose of the current study is to demonstrate state-of-the-art landscape simulation capabilities for assessing the effect of training on habitat.

This report describes the development of a dynamic, spatial, ecological model designed to help manage and protect an endangered species, the Desert Tortoise (*Gopherus agassizii*), living at Fort Irwin, a U.S. Army training center in the central Mojave Desert of California. The model will enable military planners to minimize the effect of training on the landscape. Desert landscapes, however, are exposed to many other human disturbances, including hazardous waste disposal and weapons

testing. The Desert Tortoise Model is therefore a generic prototype of the sort of tool needed to predict potential consequences and the degree of severity that highly disruptive land uses can have upon the natural and human environment. Dynamic simulation models are tools with applications extending well beyond the ecological realm and into the fields of public health, real estate development, and transportation systems.

Fort Irwin is located approximately 50 km northeast of Barstow, California. The installation is 2600 sq km; about the size of Rhode Island. The terrain is characterized by extremes: dramatic changes in elevation, temperature, and precipitation. The summer temperature can climb to 46 °C and it can fall to -7°C during the winter, the only season receiving significant precipitation (the Mojave Desert is the driest of all North American deserts). For 50 years the U.S. military has used this environment as a training center, and researchers believe that the prolonged, intensive training regime and associated disturbances (i.e., road construction and traffic) to the landscape, have had a significant impact on the Desert Tortoise habitat, as reflected in a decline of the tortoise population living at Fort Irwin between 1950 and 1990.

The Desert Tortoise Model can be categorized as a "spatially explicit model" (Pulliam, Dunning Jr., and Liu 1992; Turner et al. 1995), and "since the spatial layout of the landscape is explicitly incorporated, spatially explicit models can be used to indicate how populations or communities might be affected by changes in landscape structure" (Dunning et al. 1995). This research developed a computer-based dynamic, spatial, ecological simulation model. It is driven by a model combining mathematical, logical, and stochastic processes created and defined by the research team. The initial conditions are established by the use of a "picture" or "snapshot" of the system at some real or artificial start time. This may use various forms of input data including raster images, vector data, point information, and object status and location. Differences between the output and the seed values reveal the simulated changes within the landscape associated with various land management schemes.

## Objective

The objective of this research was to create and demonstrate a dynamic, spatial, ecological simulation model, the Desert Tortoise Model, to assist military land management offices in finding the appropriate balance between training activities and preservation of the desert tortoise habitat.

## Approach

To develop the integrated dynamic simulation, two classes of advanced students were assigned to the project as multidisciplinary research teams. The first class convened in the spring of 1994 as Geography 495 "Advanced Ecological Modeling." This practicum class consisted of the following students:

Eric Fellingner (Geography)  
Steve Harper (Ecology, Ethology, and Evolution)  
Safia Aggarwal (Landscape Architecture)  
Ken Hlinka (Geography)  
Michelle Duffield (English)  
Nupur Mohan (Landscape Architecture)  
Pablo Parysow (Forestry)  
Hsuan-Chih Lu (Urban and Regional Planning)  
Kirk Lin (Ecology, Ethology, and Evolution)

Dr. Scott Isard, a professor in the department of Geography actively participated in developing the climate submodel. Dr. Anthony Krzysik, USACERL, provided lectures, a library of material on the Mojave and Desert Tortoise, and answers to a continual stream of questions. During the summer and fall of 1994 Mr. Fellingner, working for USACERL as a research assistant, pulled several different submodels together into a single model and then converted it into a spatially explicit model. The course was offered again in the Spring of 1995. This second multidisciplinary team was joined for the semester by:

Julie Sitz (Anthropology)  
John C. Bovy (Ecology, Ethology, and Evolution)  
Shaun Levi (Geography)  
Stacy O'Leary (Geography)

This team further refined and developed the model. During the summer of 1995 the following people worked together very closely as research assistants to debug the model and get the final version running in a spatially-specific manner:

Steve Harper  
Shaun Levi  
Douglas Briggs (Computer Science)

During the entire development, the teams were supported with software developed and maintained by Dr. Thomas Maxwell of the University of Maryland's Maryland International Institute of Ecological Economics. This software allowed a model developed for two homogenous 1 sq km patches of land to be applied simultaneously to each cell in an array of cells on a landscape.

The multidisciplinary research teams used both single-cell and multiple-cell modeling tools to create the dynamic, spatial, ecological Desert Tortoise Model. The focus was to simulate pertinent environmental factors at Fort Irwin in order to capture the dynamics of the tortoise population relevant for the military's land management. The model attempts to describe such variables as preferred habitat locales and general dispersal patterns. The model makes no attempt to predict future landscape disturbances such as additional road construction, incursion of telephone poles and other buildings where tortoise predators perch, and specific training impacts. Running the model for several centuries theoretically produces a reference point for how an undisturbed tortoise population might be distributed across Fort Irwin.

This model is an experimental test-bed for evaluating the relative impacts of alternative land management scenerios. A second report will document a number of expermintns conducted with the model.

The following discussion describes in detail the construction and findings of the first step of the Desert Tortoise dynamic, spatial, ecological habitat model, and presents a proposal for the second step of model research. The discussion begins with a description of the process used to build the model and is intended to offer insight into strategies that can be used by other interdisciplinary research teams coordinating similar large-scale, ecological modeling efforts.

## 2 Pre-model Development Steps

### Identify Operational Boundary Conditions

The following discussion outlines the approach used by the multidisciplinary research team to identify the context of the modeling exercise.

#### *Model Objectives*

The most important activities before work could begin were to identify the principle objectives and scope of the modeling activity. As mentioned previously, the Desert Tortoise Model is designed to assist military land managers in finding the appropriate balance between training activities and preservation of the desert tortoise habitat (compliance with environmental regulations). Nonmilitary land management offices may also benefit from the model or models similar to it. Practically speaking, the model attempts to address the following types of questions:

- Where are the highest densities of tortoises?
- What is preferred tortoise habitat and where is it located across the installation?
- What are critical times of the year for the tortoise population (i.e., mating/nesting) and where, with as much precision as possible, do these events occur?
- How does training affect the vegetation in the tortoise habitats on Fort Irwin?
- Other than training maneuvers, what aspects of the human activities at Fort Irwin impinge upon desert tortoise habitats, and to what degree?

#### *Data Sources*

A combination of data including raster maps, satellite imagery, vector maps, and point data were used to calibrate initial conditions within the model. Vegetation coverage was provided by transect data from the Land Condition Trend Analysis (LCTA) program at USACERL. A back propagation neural network converted the data into GIS raster maps of Fort Irwin. Similarly, tortoise density data measured by Krzysik (1993) was used to generate raster tortoise density maps.

### ***Computational Environment***

The land simulation model that was applied to 1 sq km patches of land was developed with a graphical programming language called STELLA.\* STELLA is a desktop modeling tool that uses icons and schematics, linked with equations as the mechanism to build models. STELLA removes the barriers that often exist in traditional modeling/programming tools, and opens up the modeling process to a wider group of participants because it is easy to learn and operate. Within the context of the multidisciplinary team, STELLA was an excellent facilitator between the different disciplines and modeling backgrounds.

Fort Irwin was divided into a 57x57 array of 1-km grid cells. To apply the model simulation across multiple cells, STELLA equations were translated into C++ programs using the Spatial Modeling Environment (SME) developed by Thomas Maxwell, University of Maryland (Maxwell and Costanza 1993; Maxwell 1995). SME then mimics the same functions of the single-cell STELLA model, but it runs the model within each cell of the landscape. It not only runs the unit cell model simultaneously for each 1 sq km cell, but allows for movement between adjacent cells.

### **Time and Space Decisions**

Based on the model objectives, the tools, and data sources available for constructing the model, the research team defined the parameters for the model itself; namely time and space dimensions.

#### ***Time Frame***

Like weather reports generated by elaborate weather pattern models, the longer the simulation runs, the less confidence one has in the results. The same risks apply to a dynamic, spatial ecological model. How rapidly will the predictability of the model decay over time? The model may demonstrate stability at a gross scale, but reveal apparently random output at a detailed scale. In other words, the overall pattern remains the same, but details of exactly where the pattern is located may change with different runs of the simulation. To preserve the highest integrity of output and minimize the computational burden, as well as accommodate the longevity of desert tortoises (tortoises have been reported to live between 50 and 100 years) and the immediacy of land use management decisions, the "results" of the model will be gleaned from a 100-year time span. This time span will allow us also to make the

---

\* STELLA is a product of High Performance Systems, Inc. 400 Lyme Road, Suite 300, Hanover, NH 04755, (800) 332-1202.

best use of available data in capturing short-term, seasonal factors without slowing down the model and producing only overly-generalized and inaccurate results. This time frame also extends the vision of land managers by presenting a long-term forecast, rather than a short-term prediction defined by the longevity of the current generation. When coordinated with a seasonal and smaller time-step, the 100-year time span maintains an efficient calculation and running time.

### ***Time-step Considerations***

Three basic possibilities were taken into consideration as to what time-step the model should use: fixed, variable, and event driven.

**Fixed.** This is conceptually the most simple time-step, but functionally the most limiting. The model runs with a set time-step, such as a day, a month, or a year. A known time-step simplifies the model because all equations are generated with respect to the same time-step. A fixed time-step, by its definition cannot accommodate variability in the system. For example, if the time-step is weekly the model can't capture daily temperature and moisture fluctuations, or plant growth. However, a daily time-step would miss the effects of a flash flood that takes just seconds but causes great devastation to vegetation.

**Variable.** One alternative to the fixed time-step is a variable time-step; there are two options available. First, the time-step is set to a large resolution that can be dynamically modified as changes occur and are detected within the model. For example, returning to the flash flood event mentioned above, when the storm occurs the model will detect the fast changing activities taking place, and will stop the simulation, back up, and rerun the model using an appropriately smaller time-step. The second variable time-step alternative is to set different fixed time-steps to different parts of the model. This approach provides some computational relief while maintaining the relative simplicity of fixed time-steps.

**Event driven.** This approach has no time steps; rather, time is managed by a calendar that schedules events. A plant submodel within the larger model may execute plant growth and then schedule itself to be updated at some later time based on its own rate of activity. The storm submodel could be programmed to run at a specific time, and while it runs, the storm model can interact with the plant model and schedule the plant submodel to "grow" faster in response to the influx of water. This approach is most attractive for models that have limited computing resources. From a modeler's perspective, however, it is the

most time-consuming approach as it requires significantly larger simulation models to be created.

Due to software limitations, a fixed time-step was the most realistic choice available, although ideally, being able to run different parts of the model — the tortoises and the vegetation growth, for instance — at different time-steps would have been preferred. This is something to address in future research.

The most practical time-step available for this research was a 1-month time-step. It accommodated seasonal changes within the landscape, such as weather patterns, tortoise nesting and egg-laying seasons, and vegetation growth cycles. It also generates output that is reasonable to interpret versus daily or weekly time-steps that may provide too much detail, or an annual time-step with output that is too aggregated.

### ***Spatial Resolution***

The final parameter to consider was the spatial resolution of Fort Irwin. Given that the model is to be placed within individual cells across the landscape, how many of those cells are necessary to accurately describe the changes that occur over time, and how many cells can be handled given the computational limits of the available hardware? One of the key assumptions built into the model is that the spatial distribution of characters and events across the landscape is critical in understanding how these entities interact. Given that the model uses a fixed time-step, the spatial resolution needs to conform to that time-step. For example, if a predator moves 100 meters in 1 time-step over a terrain that is divided into 10-meter units, that predator will appear to be unaffected by time and space constraints. In essence, it will “warp” through space, avoiding any obstacles or opportunities in its path. Hence, a fixed time-step directly affects the resolution of the salient terrain features. Terrain resolution schemes can be categorized as follows:

**Fixed.** The terrain is divided into a regular array of square grid cells or hexagons. This is a conceptually simple strategy.

**Hierarchical.** Models that simulate activities that occur at different spatial resolutions may adopt a spatial data structure that organizes information in a hierarchical fashion. Each cell or hexagon can be iteratively decomposed into increasingly smaller components. Large entities (weather systems, flocks of birds, clouds of spores or pollens) are allowed to move rapidly across the environment using relatively long time-steps and large spatial patches.

Smaller entities (individuals or vehicles) can operate at smaller time-steps and within smaller patches. With this strategy, data is stored simultaneously at varying scales.

Variable. In the case of a large object or entity that moves slowly across the landscape (a roaming herd of ungulates, or population of invading species), one may want to preserve the entity as a whole, yet include detailed spatial structures defining the dynamically varying extent of the entity. This type of operation requires the maintenance of spatial extent at a fine resolution (such as 10 to 100 m). However, small objects can be simulated at a grosser resolution.

A fixed-cell size was determined to be the most practical spatial resolution given computer limitations, and the team selected a 1 sq km grid cell dividing the entire landscape of Fort Irwin. Tortoises have home ranges that extend up to 1 sq km and this was the primary reason supporting the team's decision. However, the area of 1 sq km does compromise details such as variations in slope, which are important in determining the likelihood of a tortoise building a burrow within a region. These assumptions will be discussed further within the tortoise submodel section of this report.

### 3 The Desert Tortoise Model

“All models are wrong. Some models are useful.” –W. E. Demming.

The Desert Tortoise Model is a collection of four separate submodels, all constructed with STELLA modeling software (see previous chapter). Each model was built by a different combination of research team members. This division of labor and cross-disciplinary approach allowed individuals to apply their expertise to the most appropriate area(s) of the project. Thus the model is an interdependent web of four distinct aspects of Fort Irwin's landscape: climate, including hydrology and temperature; vegetation; tortoise population growth; and tortoise movement.

#### Climate Submodel

##### *Purpose*

There are four main purposes of the climate-hydrology submodel:

1. Model the average monthly available soil moisture for each cell. This information is contained in the converter labeled “C\_Normal\_SM”.
2. Model the average yearly soil moisture for each cell. This information is contained in the converter labeled “C\_Max\_SM”.
3. Model a mechanism to monitor the current level of soil moisture as compared with the normal soil moisture levels. This information is managed in the converter labeled “C\_Relative\_SM”.

Climate is the driving mechanism for the model. Fundamental features of the desert climate (monthly temperature, surface temperature, precipitation, evapotranspiration, and soil moisture) are simulated.

##### *Approach*

To generate variables, the model replicates some fundamental features of the desert climate; the mean temperature, mean maximum temperature, and precipitation. Additionally, the model must simulate the extreme variability in these measures within the desert climate. This is accomplished with a “normal” statistical distribution. Temperature data are further modified based on the topographic and

elevation changes across the landscape. Data from Landsat 5 were used in a statistical regression to determine the appropriate dependence of temperature on solar azimuth angle and elevation.

The soil water balance is calculated via the classic Thornthwaite method, developed in 1948, with some alterations based on more recent findings. Mean monthly temperature values are used to calculate the potential evapotranspiration in each cell; the actual evapotranspiration depends on the degree of saturation of the soil. The change in soil moisture in each month depends on the initial level of soil moisture, the amount that evapotranspires, and the amount of water that infiltrates the soil. Infiltration is assumed to be 100 percent during the gentle polar-front rains of the winter, and 40 percent during the characteristically violent thunderstorms of the Mojave summer. Soil moisture may vary between a minimum of zero and a maximum given by the available water content of the soil. Once this maximum is reached and soil is saturated, all additional precipitation will leave the system as runoff. Due to limitations of the GIS software, surface water is not explicitly considered. Figure 1 represents the climate submodel.

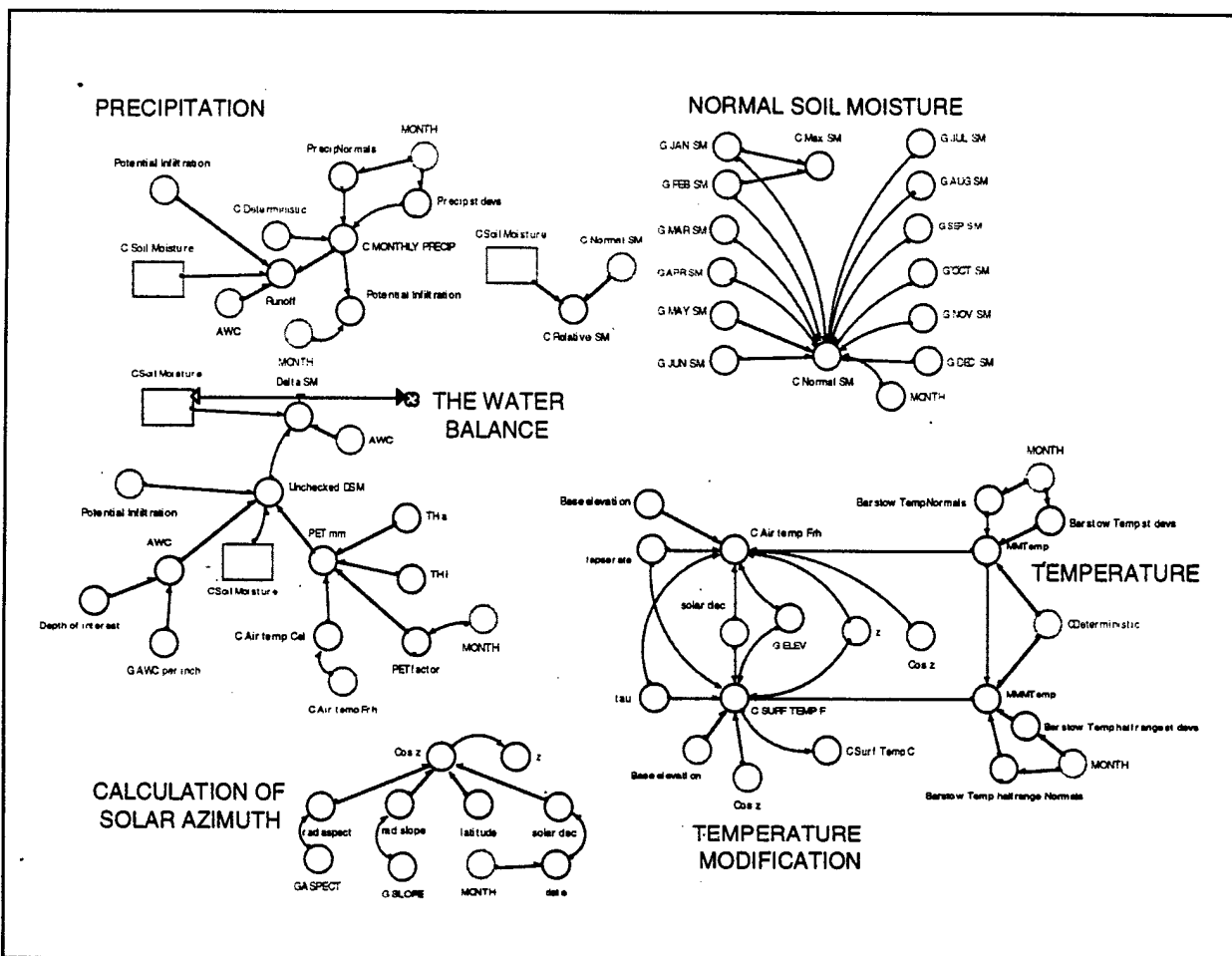

Figure 1. The climate submodel.

### Generating precipitation and temperature

A 20-year (1973-1992) historical temperature record from Barstow, California and a 20-year precipitation record from the Goldstone Echo rain gauge inside Fort Irwin were used to simulate precipitation and temperature.

Precipitation in any desert is extremely variable, though extremely low, and this variability presents a modeling challenge. The precipitation-generation module (Figure 2) reproduces the variability of the precipitation yet maintains a reasonable mean for the output. The historical distribution of precipitation at Goldstone Echo does not conform to the ordinary normal distribution, nor does it seem to correspond to a Poisson distribution. A reasonable approximation to the precipitation distribution seemed to be a normal distribution with a standard deviation equal to or greater than the mean. But this sort of distribution would incorporate negative values, and that is undesirable. So the following function is used to generate precipitation in millimeters:

$$C\_MONTHLY\_PRECIP = \text{MAX}(\text{NORMAL}(\text{Precip\_Normals}, (0.5 * \text{Precip\_Normals} + 0.2 * \text{Precip\_st\_devs})), 0) * 25.4$$

The MAX function serves to keep precipitation from becoming negative. The factor "0.5\*Precip\_Normals + 0.2\*Precip\_st\_devs", the adjusted standard deviation, was determined by a series of 50-year simulations that generated the monthly mean and maximum amount of precipitation. The adjusted standard deviation given in the equation provides sufficient variability in the output values yet does not significantly change the mean of the output distribution. Means are consistently within 5 percent of the observed 20-year value, but generated maxima are often considerably smaller than those observed. Given that long-term effects are the focus of the model, the output is acceptable.

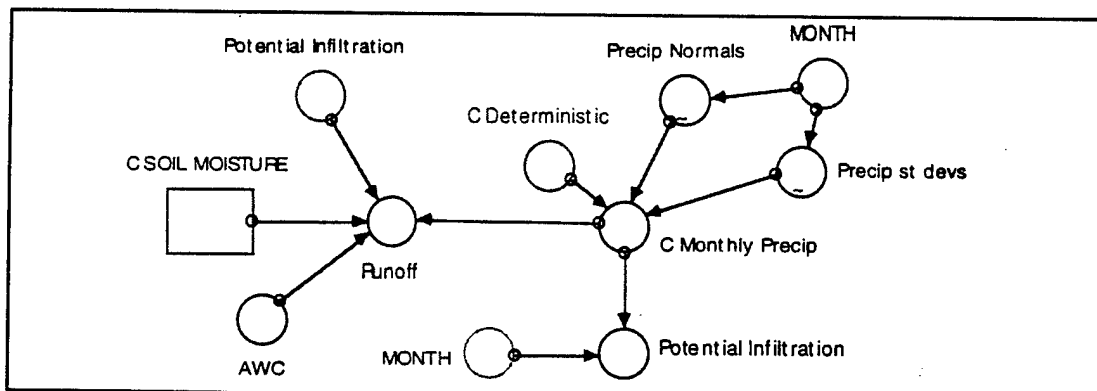

Figure 2. The precipitation model.

In higher elevations, mean monthly temperatures may dip below the freezing point of water for a time-step or more. These low temperatures should lead to snowfall. This issue is ignored, however, for two reasons. First, tortoises generally do not inhabit regions in high altitudes; they are rarely found above an elevation of 1220 m (4000 ft). Consequently, snowfall will not directly affect their habitat. Secondly, all runoff, including snow melt, is assumed to run entirely off of the base in one time-step. Thus, precipitation of any kind falling on one cell has no effect on any other cell. This feature of the model is discussed in more detail later.

Temperatures are not recorded anywhere inside of Fort Irwin, but the National Oceanic and Atmospheric Administration (NOAA) station in Barstow, approximately 10 miles east of the fort, was a suitable data source for input to the temperature module (Figure 3). This data is presented graphically in the converters "Temp/Temp\_halfrange/Precip Normals" and "Temp/Temp\_halfrange/Precip st devs". The "temperature\_halfrange" represents the difference between the monthly mean and the monthly mean maximum temperature. It was observed that the mean and mean maximum temperature data for each month were consistent with a normal distribution. Thus, actual output is generated in the model using STELLA's built-in function "NORMAL," and the observed 20-year normals and standard deviations as parameters. The outputs are labeled "MMT" (mean monthly temp at Barstow) and "MMMT" (mean monthly max temp at Barstow). The equations are:

$$\text{MMT} = \text{NORMAL}(\text{Barstow\_Temp\_Normals}, \text{Barstow\_Temp\_st\_devs}, 4322)$$

$$\text{MMMT} = \text{MMTemp} + \text{NORMAL}(\text{Barstow\_Temp\_halfrange\_Normals}, \text{Barstow\_Temp\_halfrange\_st\_devs}, 4322)$$

Thus, each month's mean temperature varies within the appropriate historical values according to a normal distribution. The maximum temperature is higher than the mean by a value that is determined in the same manner.

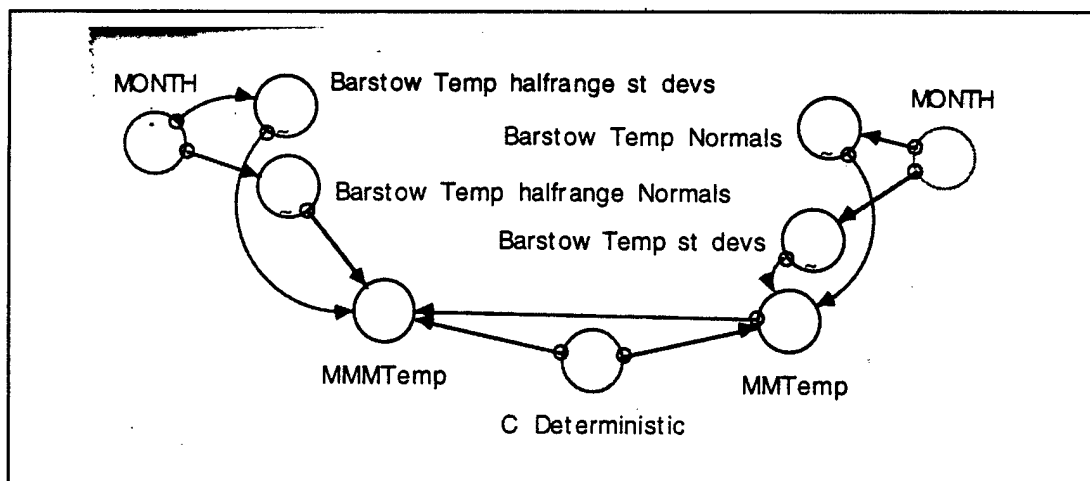

Figure 3. The temperature module.

As a general note, the use of a 1-month time-step creates one conspicuous disadvantage to the temperature- and precipitation-generation techniques; there isn't any temporal auto-correlation. In reality, a hot July or a wet July will probably be followed by a hot or wet August. The model, as it stands, does not produce this behavior. As a result, the simulated annual ranges in temperature and, especially, in precipitation, are not as great as the data suggest they should be. One possible method of overcoming this difficulty in simulating variability is to simply tabulate the historical values of temperature and precipitation and run them repetitively. This was not done because it removes the fundamental unpredictability of the desert climate. However, it is certainly a valid alternative to the approach used here.

### *Temperature modification*

As one moves up any slope, or upward through the air, the air temperature tends to fall at a rate known as the lapse rate of temperature. Therefore, temperatures at any point should be adjusted by an amount given by the lapse rate. Furthermore, those land areas that receive more direct solar energy, or insolation, will tend to be warmer than those that receive less. The amount of insolation received by a land area is determined by topography and the time of year. Regions most perpendicular to the sun's rays will receive the most insolation, and therefore be the warmest. (In mountainous terrain, there will also be shading effects; for the sake of simplicity, we do not consider these in the model.)

These details of temperature are modeled as follows (Figure 4). First, temperature is adjusted for elevation by adding the factor  $T'_e = T + \lambda (\Delta\text{elev})$ , where  $\lambda$  gives the lapse rate, and  $\Delta\text{elev}$  gives the difference in elevation between the current cell and the elevation of the station at which temperatures were recorded (Barstow, California).

Temperature is adjusted for spatially differing insolation using the concept of the solar azimuth. The azimuth, denoted here by  $z$ , is the angle between the sun's rays and the "normal" to the surface in question. In the model,  $z$  must be calculated from the slope and aspect of the cell, the latitude of the location, and the solar declination (a function of the time of year). We assume that temperatures can be corrected for insolation differences via  $T'_z = T_{45} + \tau (2\text{Cos}(z) - 1)$ , where  $T_{45}$  is the temperature observed at  $z = 45^\circ$  above the horizon. The interpretation of this equation is that when the sun's rays are normal to a surface, that surface is warmer than  $T_{45}$  by  $\tau^\circ$ ; when the sun's rays are tangent to a surface, the surface is colder than  $T_{45}$  by  $\tau^\circ$ .

The parameters  $\tau$  and  $\lambda$  were determined using a random sample of 1000 data points from a Thematic Mapper Band 6 image of Fort Irwin, from the satellite Landsat 5. The TMB6 data were converted into degrees Kelvin using the appropriate equations

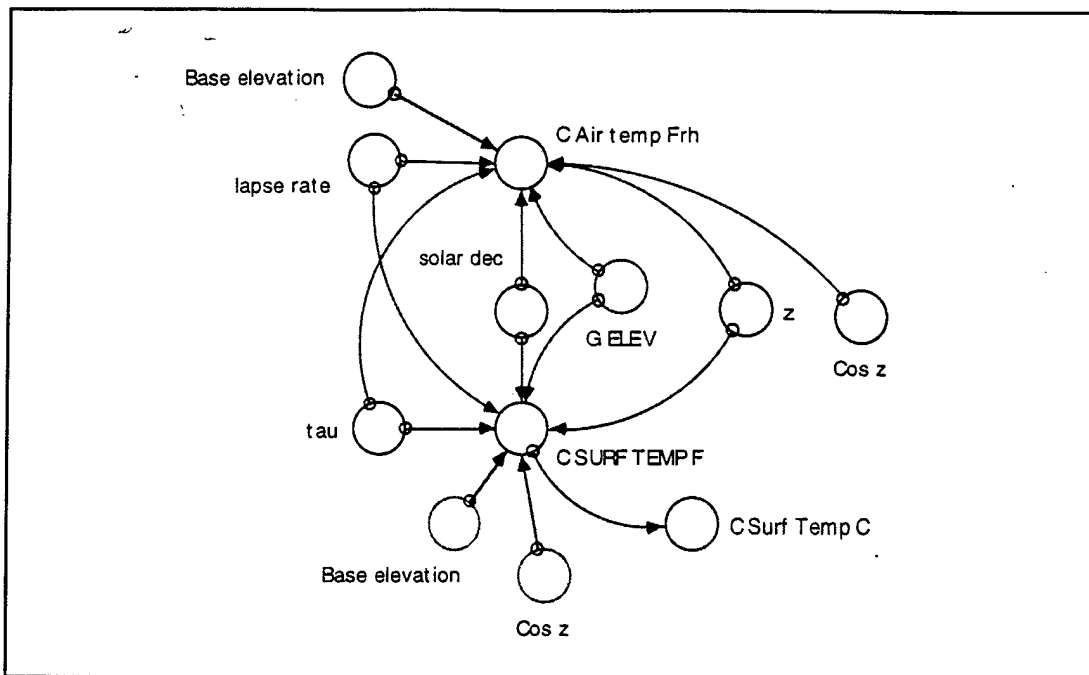

Figure 4. The temperature modification process.

from EOSTAT; Landsat Technical Notes, (No. 1, Aug 1986), allowing us to perform a statistical regression of the form

$$T' = T_0 + \lambda ((\text{elev}) + \tau (f(z)))$$

where  $f(z) = 2\text{Cos}(z) - 1$ . The adjusted r-square of the multiple regression was only 0.17, but F- and T-tests were significant to greater than 99 percent, and the resulting values of

$$\lambda = -0.00165 \text{ } ^\circ\text{K}/\text{ft} = -0.00297 \text{ } ^\circ\text{F}/\text{ft},$$

and

$$\tau = -3.71 \text{ } ^\circ\text{K} = -6.68 \text{ } ^\circ\text{F}$$

agree very well with expectations. Note that  $\lambda$  is the lapse rate of the surface temperature of Fort Irwin, which may be substantially different from the vertical, environmental lapse rate.

Having determined  $\lambda$  and  $\tau$ , only  $T_0$  remains to be determined. Due to the way in which  $\tau$  is defined,  $T_0$  must be the temperature on a cell at the base elevation, with a solar azimuth of  $45^\circ$ . Recorded temperatures were measured at the base elevation, but at an unknown solar azimuth. Here it is assumed that the measurement station

is on a flat slope. In such a case, the solar azimuth will be just the solar declination, or  $z = \delta$ , and it can be shown that

$$T = T_m + \lambda (\Delta\text{elev}) + 2 \tau (\text{Cos}(z) - \text{Cos}(\delta))$$

where  $T_m$  in the static sense refers to the recorded temperature. In the context of the climate model,  $T_m$  refers to the mean monthly temperature, based on the observed 20-year values, that was generated earlier.

### The Water Balance

The two remaining calculations performed within the model are the yearly and monthly soil moisture values ( $C\_Max\_SM$  and  $C\_Normal\_SM$ , respectively). In determining the first value, we used the climactic water balance model of Thornthwaite and Mather (1955). This model is based on the principle that moisture can be stored in the ground, up to a maximum level. Once soil is fully saturated, soil moisture accumulation ceases, and water entering the system must either leave immediately as runoff or become standing surface water. Soil moisture also can, and here frequently does, become depleted. There are many mechanisms associated with soil moisture/groundwater accumulation, infiltration and movement; however, the large time-step ( $dt$ ) used in this project, along with various software limitations, require that many simplifying assumptions be made. Figure 5 shows the water balance process.

The maximum amount of water that can be absorbed by the soil varies with soil type, and is given by a quantity called Available Water Content (AWC). An AWC value is the maximum possible soil moisture minus a typical, initial value of soil moisture for that specific soil (Bedient and Huber, 1992). Due to the high evapotranspiration and

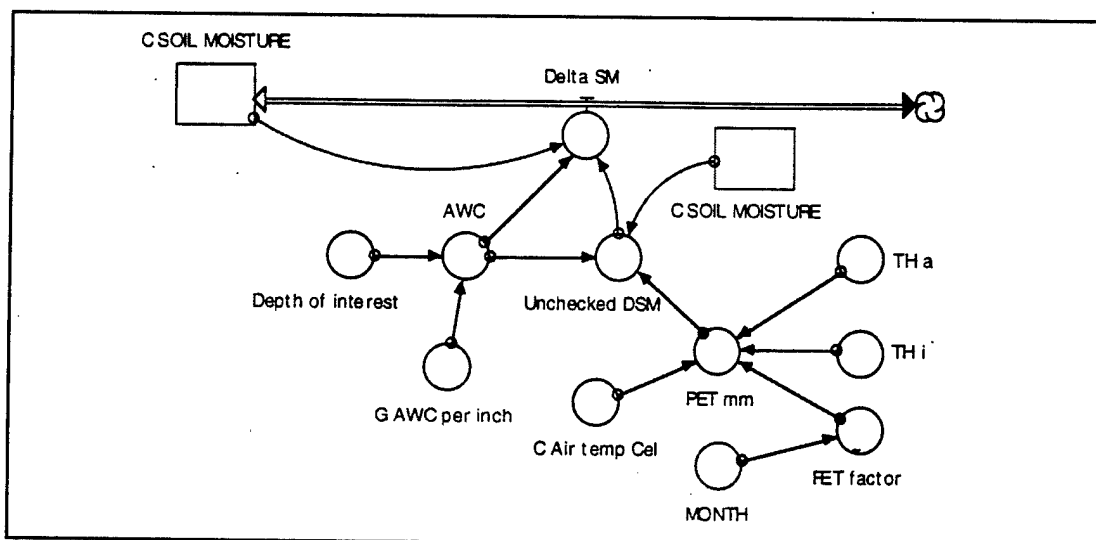

Figure 5. The water balance process.

low precipitation rates, the typical initial soil moisture was assumed to be equal to the minimum possible soil moisture. AWC values for the nine dominant soils at Fort Irwin were obtained from the U.S. Department of Agriculture, Soil Conservation Service located in Davis, California. These data are given in units of "inches per inch," meaning the available content in inches per inch of soil depth. Since we wish to model the actual volume of water present in the soil, we must assume a subsurface depth at which the existence of water will be unimportant for plants; we call this depth the "depth of interest." We assume a depth of interest of 30 centimeters, a reasonable approximation of the typical "rooting" depth of plant species frequently consumed by tortoises. This value, however, can be changed readily by adjusting the Depth\_of\_interest converter in the STELLA model.

There are five components of the water balance process: precipitation (previously discussed), infiltration, evapotranspiration, runoff, and the stock of soil moisture.

**Infiltration.** Not all precipitation that falls on an area necessarily infiltrates the soil, even if the soil moisture is not at capacity. Several factors regulate the maximum rate at which a given soil type will allow infiltration. However, the use of measured infiltration rates naturally requires values of duration and intensity of precipitation. These latter data are not available; only monthly precipitation totals are available. Therefore, we make some coarse assumptions.

The precipitation regime at Fort Irwin has dual maxima; one in the winter (a broad peak of about 1 inch per month from January through March) and one in July (a rather sharp peak of 0.7 inch). Winter precipitation in the Mojave desert typically occurs very steadily, and is brought by polar-front cyclones that are severely weakened by passing over the Sierra Nevada Mountains. Summer precipitation, on the other hand, consists of sporadic, violent thunderstorms that originate over the Gulf of California. We assume that if the soil is not saturated, all winter precipitation will be absorbed due to the slow rate of influx. On the other hand, because of the intensity of summer storms, their short duration, the highly variable slopes, and the soil composition, we assume that approximately 60 percent of the summer precipitation will run off.

General hydrologic principles related to recharge of aquifer systems indicate that only 10 percent of precipitation will infiltrate the soil and find its way to an aquifer system as recharge (Visocky and Sherril 1985). This is typical for recharge in the Midwest; however, this recharge is regulated and directed by the large percentages of silts and clays associated with the soil matrix. Desert soils do not contain high percentages of silts and clays and this allows large amounts of precipitation to infiltrate under the right circumstances. High infiltration is corroborated by the high permeabilities (rate of diffusion of a fluid through a porous body under standard

conditions of area, thickness, and pressure) found in desert soils. These permeabilities are as high as 20 inches of infiltration per hour for some soils. This allows us to assume that all the precipitation that falls during the winter months infiltrates into the soil because of the gentle nature and long period of this rainfall. The short, intense nature of the summer rains motivates the assumption of the lower infiltration rate of 40 percent, with 60 percent of the precipitation leaving the system as runoff. Information collected and presented (Evans, Sammis, and Cable 1981) supports these general assumptions.

**Evapotranspiration.** Evapotranspiration is the total of all water naturally leaving the ground surface and the leaves of plants in gaseous form. Here we use the Thornthwaite model of evapotranspiration (Thornthwaite 1948), which is an empirically derived relationship between mean monthly temperature and soil moisture. The natural energy-demand for water is represented by Potential Evapotranspiration (PET). This quantity is given by:

$$PET = 1.6 * PET\_factor * (10 * Air\_temp\_Cel / TH\_i)^{TH\_a}$$

where TH<sub>i</sub> and TH<sub>a</sub> are site-specific functions of the average monthly temperature of the area and the PET<sub>factor</sub> corrects for not having 12-hour days and 30-day months. PET gives the amount of water that will be evaporated if there is an infinite supply. (Note: the constants in the Thornthwaite model are designed for use with temperature data in units of degrees Celsius, and give PET in units of centimeters.)

Actual evapotranspiration (AET) is that amount of moisture that leaves the surface in gaseous form, and will differ from PET due to finite water availability. Thornthwaite (1948) gives the equation:

$$AET = PET * Available\_Soil\_M / AWC$$

More recent work (Abdul-Jabbar et al. 1983; Sammis et al. 1986) suggests a modified form of this relationship for use in arid regions:

$$\begin{aligned} \text{IF } Soil\_M/AWC &\leq 0.5 \\ \text{THEN } AET &= PET * 2 * Soil\_M/AWC \\ \text{ELSE } AET &= PET \end{aligned}$$

This is the form we use. Clearly, if soil is saturated, evaporation will take place at just the level determined by PET, as is required.

**Problems with the Thornthwaite model.** While the Thornthwaite model of evapotranspiration, is well known and simple, a great number of recent studies show

it to be inadequate at precisely predicting actual evapotranspiration, particularly in very arid regions. Jain and Sinai (1985) show that the Thornthwaite model underestimated values of AET by as much as 50 percent during hot months in the Jordan Valley of Israel. Salih and Sendil (1983), working in central Saudi Arabia, show that the Modified-Jensen-Haise method of predicting AET generates the most accurate results, a finding that is corroborated by the work of Samani (from a discussion in Salih and Solaiman 1989). Salih and Sendil (1983) go on to show that methods to estimate AET that use only temperature data (such as the Thornthwaite model) are consistently less accurate predictors of AET than methods that incorporate some other variable. The Modified-Jensen-Haise method, for example, requires both temperature and insolation data.

Since only reliable temperature data were available to us, we were precluded from using a more sophisticated model, incorporating variables such as insolation or average wind speed, in the analysis. Furthermore, models such as the Jensen-Haise method tend to be designed for prediction at a smaller temporal scale, such as 1 day. Thus, as it stands, the model may tend to overestimate available soil water, particularly in the summer. As a result, the sensitivity of the modeled ecosystem to extremes in temperature may be mitigated.

***Vegetation and evapotranspiration.*** Most water balance models make use of empirical data relating AET to the vegetative cover (Sammis et al. 1986). At this point, though, it would appear that the appropriate connection has not been completed. Evans, Sammis, and Cable (1981), analyzing AET at four desert sites, found that: "In no case was there an appreciable difference in evapotranspiration rates between a bare soil and an adjacent vegetated plot for any extended period of time" (p 217). No finding to the contrary has been discovered, so we assume that evapotranspiration will have no dependence on the vegetative cover at any point within Fort Irwin.

***Runoff.*** In the Thornthwaite model, the water that neither infiltrates nor evaporates is referred to as the surplus. Surplus water must either become surface water at the cell where it falls or become "runoff," and flow out of the cell. Naturally, the terrain will determine which of these occurs.

We do not consider surface water primarily because in the current desert climate, though surface water may exist, it generally will not stand for an entire month, which is the length of the time-step. Given the terrain of Fort Irwin, semipermanent surface water will be spatially rare. Since we explicitly assume no surface water, all surplus water in the water balance must leave the system as runoff. We make an assumption that is very important to note, namely that within each month, surplus

water not only leaves the cell on which it falls as precipitation, but that it leaves the entire base. Via the equation:

```
IF Potential_infiltration > AWC - C_Soil_Moisture
  THEN Runoff = C_Monthly_Precip - (AWC - C_Soil_Moisture)
ELSE C_Monthly_Precip - Potential_infiltration
```

Runoff is constrained to be just the difference, if any, between water that falls as precipitation and water that infiltrates the soil. The lesser value of Potential\_infiltration and AWC minus C\_Soil\_Moisture is the amount of water that infiltrates the soil.

There are many highly technical model simulations related to hydrologic processes that potentially could be incorporated into this project; however, these models typically work at time-steps well below the 1-month time-step in this model. Time-steps on the order of minutes are common. Also, the hydrologic principles of infiltration, runoff, leakage, absorption, interception, saturation, etc., all require detailed field data for calibration. Much of these data are, to date, not available for this area. To this end, this portion of the project included detailed discussions and attempts to incorporate a more advanced model for determining soil moisture, infiltration, and runoff. Unfortunately, the lack of appropriate data and the time-step constraint prohibited the use of such a model. Given the hydrologic setting of this area, this seems to be a reasonable approach.

**Delta SM (change in soil moisture).** The amount by which the stock of soil moisture changes is controlled by the flow, "Delta\_SM". If evapotranspiration exceeds infiltration, there will always be withdrawal from the stock. However, if more precipitation falls than can be evaporated, the soil will be recharged only to the extent that it can absorb water. Once the soil is saturated, all additional precipitation will run off.

If none of the above-mentioned constraints are encountered, the change in soil moisture will be just the difference between the water that evapotranspires from and the water that permeates into the soil. Carefully considering this relation, however, one will note another drawback to the use of a 1-month time-step. The unmodified time-series relationship would be

$$SM_{t+1} = SM_t + I_t - AET_t$$

where  $I_t$  and  $AET_t$  are the infiltration and actual evapotranspiration, respectively, in month  $t$ . But recall that if the soil is less than one-half saturated,  $AET$  is given by

$$AET_t = SM_t * PET_t / AWC$$

Since  $SM_t$  depends on infiltration in the previous month ( $I_{t-1}$ ), we see that water is available to be evaporated only in the month following the period in which it falls as precipitation. As a result, evapotranspiration tends to lag precipitation by a month, a phenomenon that is intuitively unsound and presents several practical problems.

This lag effect can be eliminated by modifying the equation for  $AET$ , replacing  $SM_t$ , the initial monthly value, with an estimate of the average monthly value given by  $(SM_{t+1} + SM_t)/2$ . Thus we assume that in calculating the water balance, the average monthly soil moisture is a better basis for the calculation of  $AET$  than the initial value. So now, using

$$SM_{t+1} = SM_t + I_t - \frac{SM_{t+1} + SM_t}{2} \times \frac{PET_t}{AWC}$$

we get

$$SM_{t+1} - SM_t = \Delta SM_t = \frac{I_t - SM_t \frac{PET_t}{AWC}}{1 + \left( \frac{PET_t}{2 \times AWC} \right)}$$

This relation is used in the model, within the converter "Unchecked DSM". The constraints on  $\Delta SM$  imposed by the soil's AWC are imposed in calculating the flow "DSM".

**Soil Moisture.** By "turning off" the randomization of the temperature and precipitation values, and simply using the 20-year mean values in a simulation run, an initial value of soil moisture can be determined. We refer to this as a deterministic run of the model, and can be accomplished through the converter-flag labeled "C\_Deterministic". If this flag is set to zero (turned off), precipitation and temperature will vary within normal distributions, as discussed. If set to one (turned on), the model will generate precisely the mean monthly temperatures and total precipitation for each month, year after year. In a deterministic run, any initial setting and given AWC will quickly yield an unchanging temporal pattern of soil moisture. Since January is the first month when the model is run, the December

value of soil moisture is used as the stock initialization (Figure 6).

The average monthly AWC of the soil for a given month was generated using a deterministic run of the climate sector. The monthly output was in the form of spatially-explicit maps; one for each month. These individual maps are then used as the "normal" monthly soil moisture values for each cell and these values are compared to the current soil moisture, "C\_Monthly\_SM", when determining the index of soil moisture.

"C\_Max\_SM" is the maximum soil moisture in a year. It is either the soil moisture found in January or in February, the months following the wettest season of the year within the desert.

$$C\_Max\_SM = \max (G\_JAN\_SM, G\_FEB\_SM)$$

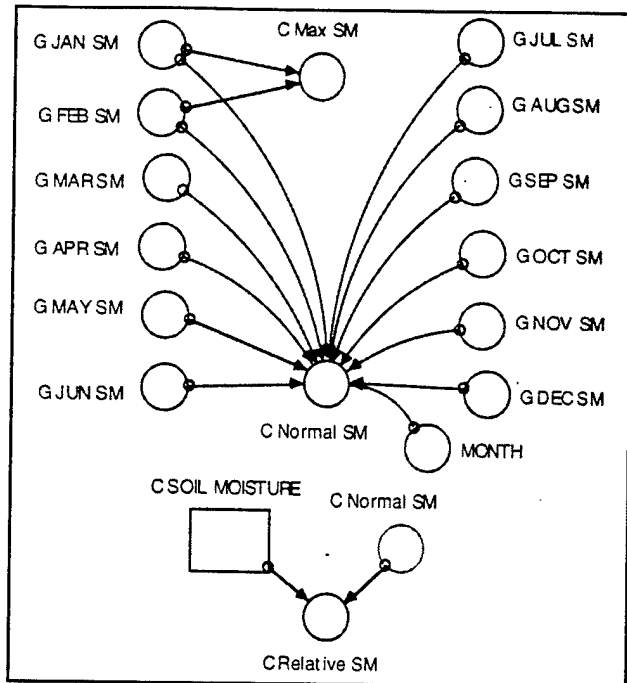

Figure 6. The soil moisture module.

## Vegetation Submodel

The vegetation submodel (Figure 7) provides a rough rendering of the current plant community distribution and growth at Fort Irwin. The plant community can have direct, indirect, and interactive effects on desert tortoise populations at Fort Irwin. Desert tortoises are herbivores during the majority of their life span, therefore, they satisfy energy and nutritional demands, including a proportion of water consumption, by consuming plants. Because tortoises are tightly linked with the producer trophic level, they may be directly affected by changes in vegetation quantity or quality. Predicted direct effects of decreased vegetation include decreased available energy, nutrients, and water for tortoises. Similarly, changes in vegetation quantity or community type may change the habitat structure experienced by tortoises. For example, decreasing vegetative cover will reduce available shaded areas that provide shelter from the hot sun during the day. Tortoise growth rates, physical condition, survivorship, space use, and reproduction all may respond directly to alterations within the plant community.

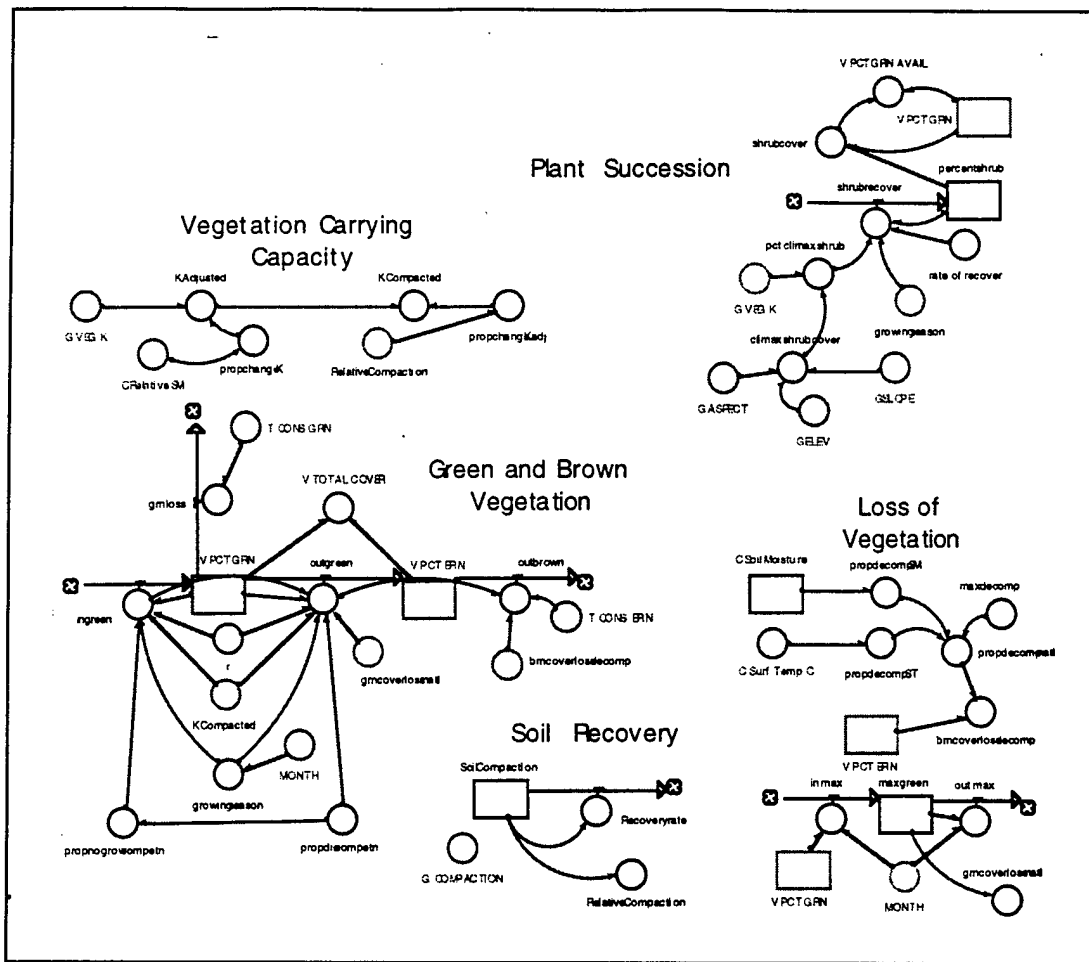

Figure 7. The vegetation submodel.

The plant community may also have indirect effects on desert tortoise populations, such as a decline in vegetation cover that may increase the risk of tortoises encountering predators. Or the effects of vegetation quality or quantity may be interactive (the effect of one factor is conditional, depending on the level of another factor). For example, mortality factors like disease or predation, may become important only when animals are experiencing energetic, nutritional, or water deficits brought about by decreases in the plant quality or quantity.

**Approach**

A GIS map of total vegetative cover for Fort Irwin was generated from actual cover estimates determined at 200 randomly selected points. These data were collected and made available in conjunction with the Land Condition Trend Analysis (LCTA) program at USACERL. Each point represents a 100-m linear transect. For each transect, a rod was dropped vertically at 1-m intervals, with the height and species of vegetation recorded for every plant that touched the rod. An estimate of aerial cover was calculated as the percentage of the sampling points along a transect that

touched some vegetation. Because plants were identified as species, we were also able to generate individual estimates of cover for shrubs, forbs, and grasses.

Maps of vegetative cover for the entire base were generated using a back-propagation neural network (Wu and Westervelt 1994). The neural network determined the best correlation between the ground truth data and existing maps (satellite images from thematic mapper bands 1 through 7, elevation, slope, watershed, and road buffer). These correlations were then used to extrapolate vegetation cover estimates from the ground truth data to the entire base. The amount of vegetation on Fort Irwin was quantified in units of percent aerial cover rather than as numbers of plants or amount of biomass. The dynamics of seasonal changes in vegetation were described using the logistic equation (Ricklefs 1990):

$$dN/dt = rN(1-N/K)$$

The rate of increase decreases as a linear function of the size of the population (N). When the population size is lower than the carrying capacity (K), the population continues to increase, although at a slower rate, as population approaches the carrying capacity.

### ***Vegetation Carrying Capacity***

Carrying capacity maps were also generated with a back-propagation neural network that determined the best correlation between the "permanent" physical characteristics of the cell (e.g., slope, aspect, soil type, elevation) and data from 500 points randomly selected from the northern section of Fort Irwin. This northern area is assumed to be at or very near "original" carrying capacity given that the region hasn't been exposed to severe human impacts. Figure 8 shows the vegetation carrying capacity module.

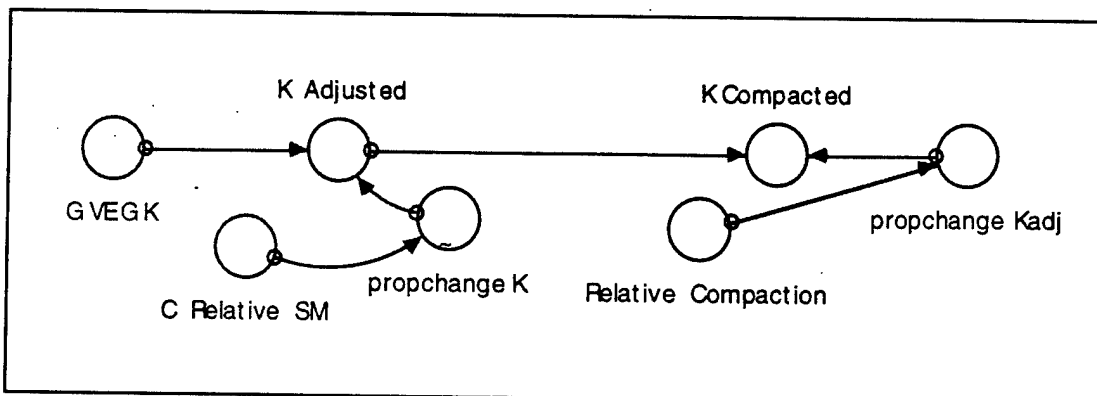

Figure 8. The vegetation carrying capacity module.

It is possible for the initial vegetation ( $t = 0$ ) in cells previously impacted by human activity to be significantly below the carrying capacity determined by permanent physical factors. The model assumes a negative linear relationship between the carrying capacity and the degree of human activity within the cell. Thus, the carrying capacity, "K\_compacted", was reduced by a fixed proportion relative to soil compaction.

$$K\_Compacted = K\_Adjusted - (K\_Adjusted * propchange\_Kadj)$$

where "propchange\_Kadj" converts the impact of relative soil compaction index into the proportional decrease in vegetation carrying capacity. "Propchange\_Kadj" is derived from the soil compaction index, "Relative\_Compaction", that converts the level of soil compaction within each cell into an index between 0 and 1 based on soil strength,  $17 \text{ kg/cm}^2$ , and undisturbed soil strength,  $4 \text{ kg/cm}^2$ .

$$\text{Relative\_Compaction} = (\text{Soil\_Compaction} - 4) / 13.$$

As carrying capacity values in general were assumed to correspond to average soil moisture conditions, carrying capacity of each cell was predicted to be affected by yearly variability in soil moisture. The carrying capacity within each cell increases when the current monthly soil moisture is greater than the average, and decreases when less than the average, "K\_Adjusted". Although the exact magnitude of the effect of relative moisture on the carrying capacity has not been documented, desert plant communities have been shown to be strongly affected by the timing and amount of precipitation (Beatley 1974; Inouye 1991; Lane, Romney, and Hakonson 1984; Schlesinger and Jones 1984). Additional human impacts beyond conditions already present at the installation have been ignored and, consequently, the carrying capacity will increase as the soils regenerate and plant succession evolves. Thus, the impact that compaction has on the carrying capacity will decrease, the "propchange\_Kadj" will approach zero, and carrying capacity will resume a predisturbance carrying capacity of "K\_Adjusted" where moisture is the primary limiting factor.

### ***Plant Succession***

The vegetative community within each cell was described in terms of major plant categories (shrubs and annuals) and phases of growth (green and brown). This approach allowed the model to describe community level shifts in composition due to disturbance and secondary successional changes, yet it also eliminated the need for a highly detailed model that is required if individual plant species are modeled (Figure 9 shows the plant succession module). The percent shrub cover at the climax state was determined in a manner similar to that used to calculate the carrying



### Green and Brown Vegetation

Although the intrinsic rate of population increase may be directly affected by the physical environment, it is primarily a characteristic of individual populations of a species. This measure is empirically determined from life-table information (Ricklefs 1990). Because such detailed knowledge of growth rates was deemed unnecessary, the research team estimated a single intrinsic rate of increase value ( $r$ ) for all green vegetation. The green vegetation in both community types was estimated to closely approach the carrying capacity of the cell during the growing season (period of vegetative growth and reproduction). The growing season for both community types was determined to be during the 6-month period from December through May (Beatley 1974). For the vegetation to approach the carrying capacity during the growing season, it was determined that an intrinsic rate of natural increase of 0.85 was required. Following the growing season, most green vegetation became senescent and is classified as brown vegetation within the model. All communities (i.e., any combination of shrubs and annuals) were assumed to have green cover at the beginning of the growing season equal to 25 percent of the maximum green cover of the previous growing season. This approach simulated the observations that part of the shrub leaves remain green over the summer and fall months and that there is mass germination of annuals before the beginning of the growing season specified in the model (Beatley 1974). The senescence process was modeled to occur in a linear fashion over the 6 nongrowing months. Thus, the values of  $r$ , proportion green vegetation at the start of a growing season, and length of growing season were defined in the model independent of community type. Figure 10 shows the green and brown vegetation module.

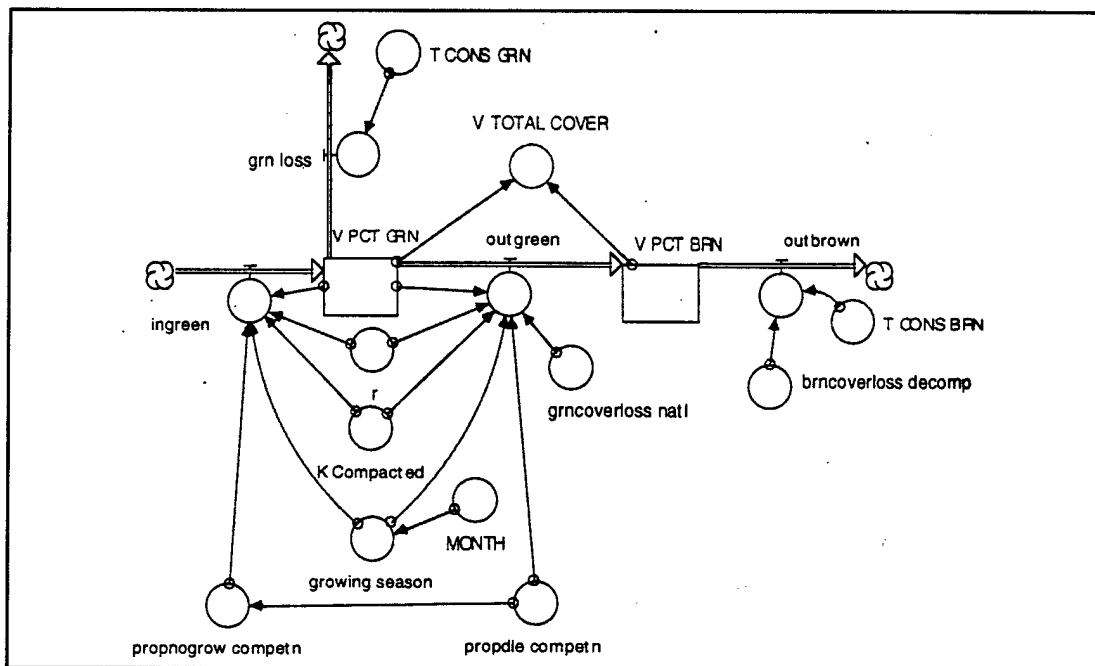

Figure 10. The green and brown vegetation module.

Brown vegetation (i.e., litter and standing dead), plays an important role in desert ecosystems, especially in nutrient cycling, energy flow, seedling establishment, and invertebrate activity (West 1979). Brown vegetation is included in the model because it can be consumed by tortoises, although it is not preferred forage. Brown vegetation is lost from the system via decomposition. Rates of decomposition play an important role in the desert ecosystem, especially with regard to nutrient cycling and energy flow (Zak and Freckman 1991); however, there is little known about the litter consumers and decomposition rates in North American deserts (West 1983). The structure and density of soil microfauna may be strongly affected by abiotic components, especially soil moisture and temperature (Zak and Freckman 1991), although the quantitative relationship between decomposition rates and these physical factors has not been described for natural systems. Generally, substantial accumulation of litter is not observed in deserts (except directly under shrubs, in excavations, or in arroyos; see Whitford 1986). A model of decomposition rates has been proposed (Goodall 1981); however, this model was considered to be too detailed to be useful for the tortoise model. Decomposition rates of the present model were estimated as a function of soil moisture and surface temperature so that results were consistent with the observation that litter does not accumulate to substantial levels. Vegetation is also decreased due to tortoise consumption, but this has minimal effect on the actual vegetation cover.

## **Desert Tortoise Submodel**

### ***Purpose***

This submodel of tortoise population dynamics serves as the key component of the overall model. Inputs from the three other submodels coalesce in this section and determine the potential impacts that different levels of habitat quality, and eventually training impacts, will have on the desert tortoise population at Fort Irwin. Because the desert tortoise is both an endangered species and an indicator species for desert ecological conditions, the information generated in this submodel should be valuable for developing effective management strategies.

### ***Approach***

Five stocks (or cohorts) representing desert tortoises at different stages of their life cycle form the basic structure of the tortoise submodel (Figure 11). Factors such as birth, death, recruitment, and mortality change the number of tortoises in each of these stocks. These influences vary in intensity depending on changes in habitat condition over time. These five cohorts are: eggs, hatchlings, juveniles, adults, and elders, and are divided according to their age. This method of categorization agrees

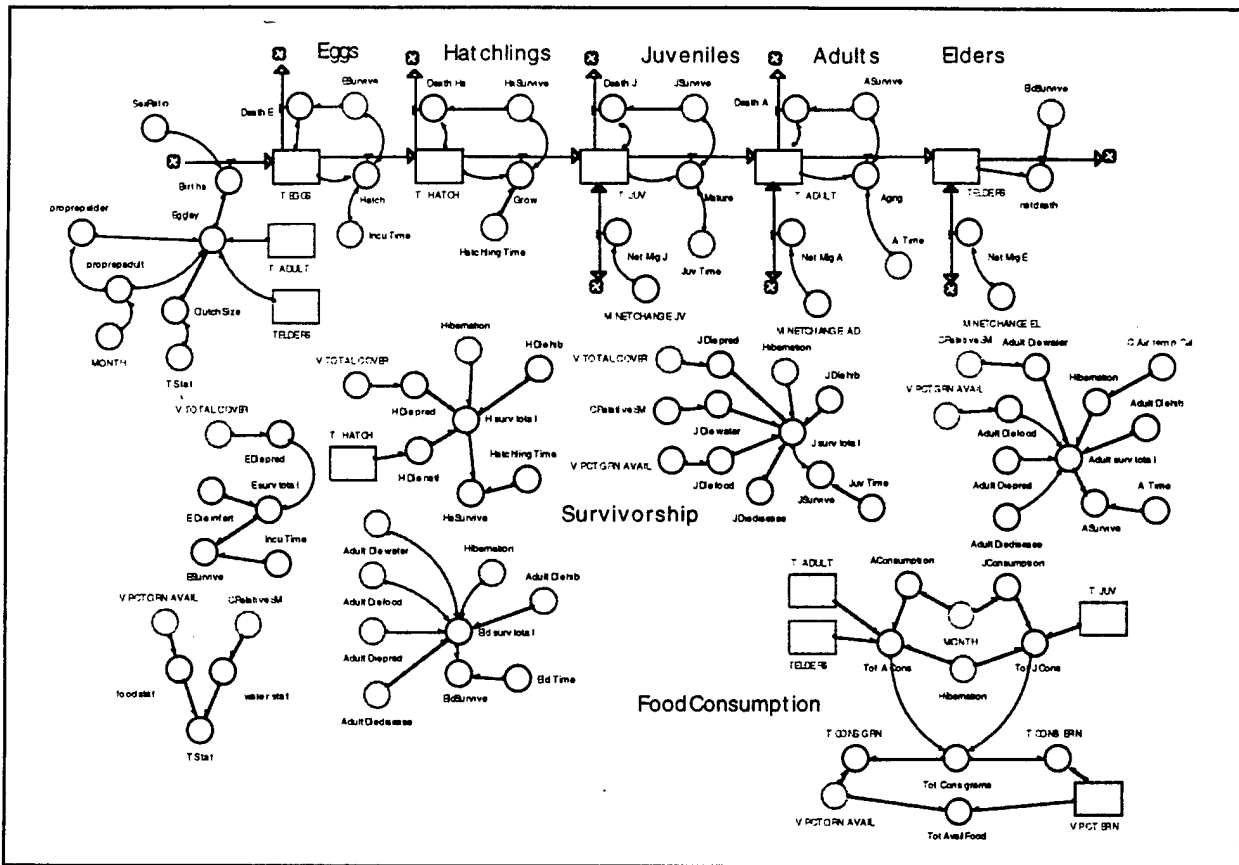

Figure 11. The tortoise submodel.

with classification systems presented in the literature (see pp 56-59 in Hohman, Ohmart, and Schwartzmann 1980), and will be further explained in the following sections.

Only the female members of the tortoise population are represented in the model. The decision not to model males was based on two specific reasons. One reason is that the long-term sex ratio remains close to parity as a result of migration. Evidence for this argument comes from Berry (1976), who analyzed four desert tortoise populations and found that in all four populations the sex ratios were close to 1:1 (p 40). The second reason is that only the females lay eggs. Their ability to store sperm ensures that even occasional contact with males will allow them to lay viable eggs. Therefore, the total tortoise population is achieved by doubling the female population total.

Limited appropriate quantitative data in the literature necessitated the interjection of educated assumptions in order to construct the model. For example, although tortoises are known to prefer succulent, green forage to dry, brown plants (Avery 1992; Esque 1994; Henen 1992), data on the exact quantities of forage consumed by tortoises was not available — at least not in a form that could be readily and accurately used in the model. Indices were used to capture the correct relationship

between factors such as food, water, predation, disease needed for calculations to determine the number of tortoises in each cohort that will survive during each time-step.

### Submodel Cohorts

The five main sections of the submodel and explanations of the equations influencing them are presented in the following paragraphs.

**Eggs.** The first stage in the desert tortoise life cycle is the egg cohort, represented in the model by the stock "T\_EGGS". Eggs flow into this stock through "Births" and flow out either through losses due to egg mortality, represented by "Death E" or through recruitment to the hatchling cohort, represented by the outflow entitled "Hatch" (Figure 12).

Tortoise births in the model take place as a result of adult and elder egg-laying (elder tortoises are assumed to have a lower reproductive rate). Breeding activities in the wild take place during the spring, with peak breeding in March and June. Eggs are laid in the model after a 3-month gestation, during the months of May through July

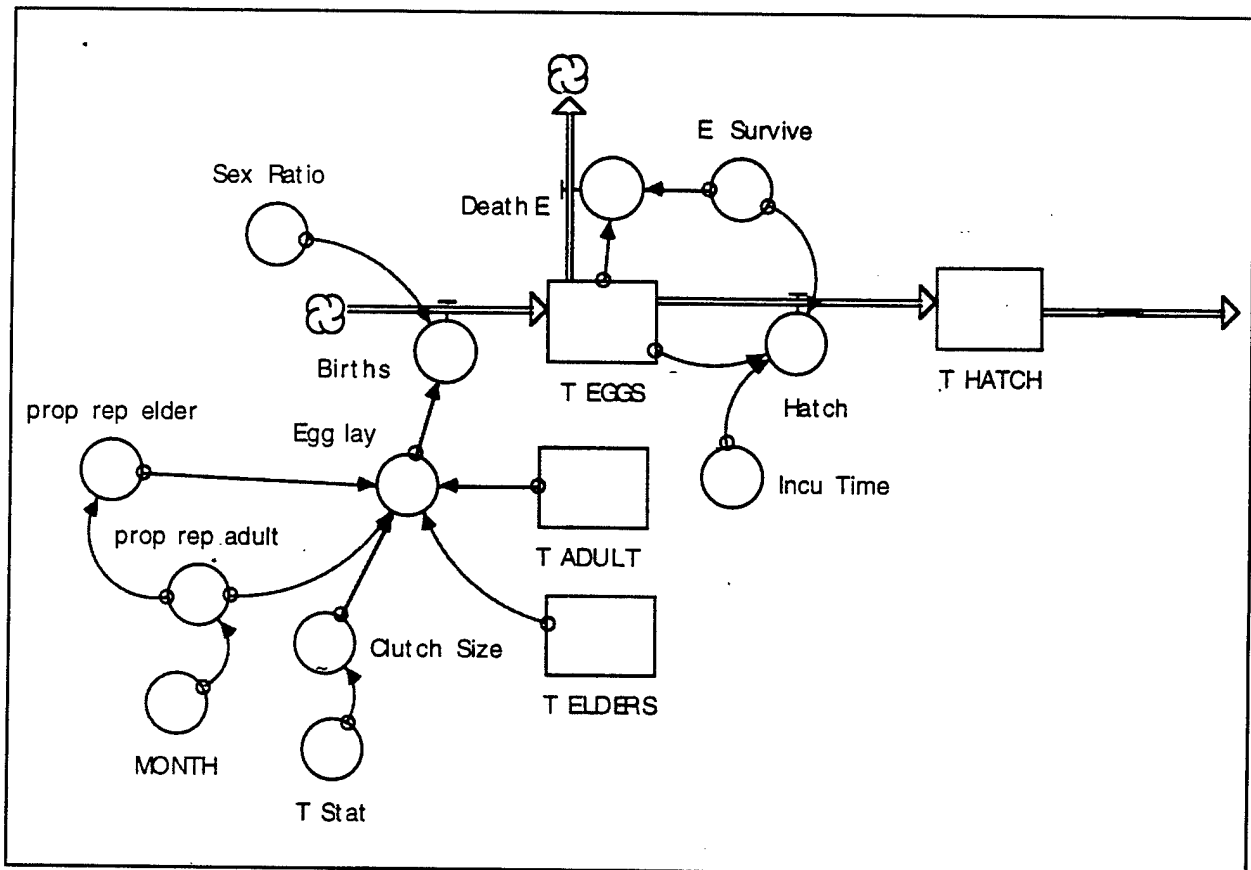

Figure 12. The eggs cohort of the tortoise submodel.

(Luckenbach 1981; Woodbury and Hardy 1948). Given that females have the ability to produce multiple clutches, the "prop\_rep\_adult" variable delineates a decreasing percentage of the adult population that is likely to reproduce during the spring. Research and observation of tortoises under natural conditions indicates that females can produce either one or two clutches of eggs per year (Ernst and Barbour 1972; Luckenbach 1981), but other research indicates not all females lay a clutch every year (Hohman, Ohmart, and Schwartzmann 1980). This model assumes that on average each adult female lays 1.84 clutches per season. Consequently, the model subdivides the proportion of adult tortoises that reproduce as follows: 100 percent of the population lay eggs in May, 80 percent in June, and 4 percent in July. This assumption is based on fieldwork that found the percentage of reproductive females observed laying one clutch was 100 percent, and 84 percent of females laid a second clutch during that same breeding season (Turner et al. 1984).

```
prop_rep_adult = If MONTH = 4 then 1.00 else if MONTH = 5 then 0.80 else if
MONTH = 6 then 0.04 else 0.00
```

Note that the model begins at time-step 0, which is January. So month 4 represents May, and month 12 corresponds with the second January.

Elder female tortoises also reproduce, but at a reduced rate of about 30 percent of the adult tortoise population (personal communication, Dr. Anthony J. Krzysik, Ecologist, USACERL, summer 1995). Incubation time is 3 months (hatching occurs between August and October), or three time-steps, which is consistent with the literature (Hohman, Ohmart, and Schwartzmann 1980; Luckenbach 1981).

The frequency of clutch production and the actual number of eggs produced in the model tortoise population are associated with the physical condition of the tortoise, "T\_condition", which is an index that calculates the number of eggs laid by female adults and elders. The health or condition of the tortoise determines the size of the clutches produced. In the wild, clutch size averages from four to five eggs, although numbers as low as two and as high as fourteen have been documented (Ernst and Barbour 1972; Luckenbach 1981). The model assumes a correlation between tortoise condition and habitat quality such that if the vegetative cover is sparse and water availability low, fewer eggs will be produced; whereas, good habitat conditions result in higher egg production levels — up to a maximum of 14 eggs per clutch per reproductive female (Hohman, Ohmart, and Schwartzmann 1980). Once the number of eggs produced per female per time-step (dt) is calculated, the total number of eggs laid per cell per dt, "Egg\_lay", can be determined using the equation:

$$\text{Egg\_lay} = \text{Clutch\_Size} * ((\text{prop\_rep\_adult} * \text{INT}(\text{T\_ADULT})) + (\text{prop\_rep\_elder} * \text{INT}(\text{T\_ELDERS})))$$

The sex ratio within the desert tortoise population is approximately 1:1. Thus, dividing "Egg\_lay" in half (the "Sex\_ratio" variable) yields the number of female "Births" added to the cell's tortoise population each time-step.

While the literature provides some description of egg survivorship rates, this information is not specific and assumptions have to be made about the interaction and importance of different factors affecting egg mortality. Research has found that "it is common for 50% of a clutch from desert tortoises in captivity to be infertile, and similar losses may occur in the wild" (Luckenbach 1981), and that predation could account for approximately 23 percent of prenatal mortality in one desert tortoise population (Turner et al. 1984). Egg survivorship within the model, "E survive", became a function of predation ("E Die pred") — a constant that mimics Lukenbach's findings of 50percent — and infertility ("E Die infert") — an index based on vegetative cover. We assume that in cells with better cover, mortality due to predation is reduced; vegetative cover camouflages tortoises and their nests (we have not found documentation that supports this conclusion, but it seems logical). Egg survivorship is then calculated with the following equation:

$$E\_survive = EXP (LOGN (E\_surv\_total) * (1/Incu\_Time))$$

This equation is devised in such a way as to compensate for the discrepancy between the fixed time-step embedded within the model and the real world maturation time that tortoise eggs require (Hannon 1994:pp 110-114).

Under natural conditions, incubation generally has been observed to vary between 90 and 120 days (Luckenbach 1981). As mentioned earlier, the model assumes a 90-day incubation time. Immediately after tortoises emerge from their shells, they move into the hatchling cohort of the model.

**Hatchlings.** The next stage in the desert tortoise life cycle is the hatchling cohort, represented in the model by the stock "T HATCH". As mentioned earlier, hatchlings flow into this stock from the egg cohort through "Hatch", and they flow out either through losses due to hatchling mortality, represented by "Death Ha" or through recruitment to the juvenile cohort, represented by the outflow titled "grow" (Figure 13).

From the desert tortoise literature, the actual annual mortality rate of hatchlings is not known (Turner et al. 1984). So, like egg survivorship, assumptions were made to calculate hatchling survivorship, "Ha Survive". Hatchling survival depends on when the tortoises are hibernating or aestivating, predation, and natural causes including inadequate food or water supply. With the exception of eggs, all cohorts of tortoises hibernate and aestivate (Medica, Bury, and Luckenbach 1980).

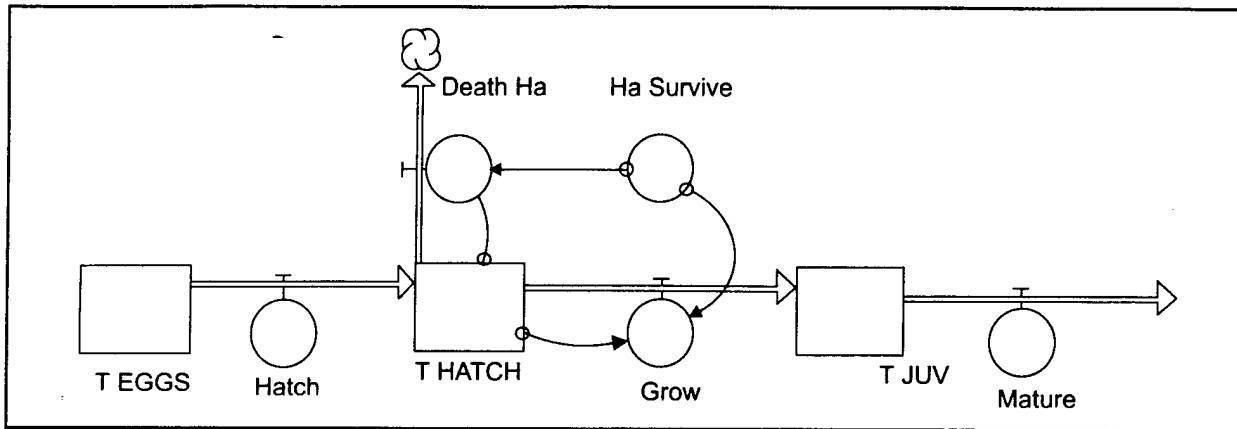

Figure 13. The hatchling cohort of the tortoise submodel.

Hibernation generally occurs during the fall and winter in the months November through February (Luckenbach 1981), and aestivation usually occurs in midsummer when temperatures approach 39.5 °C, at which point tortoises would experience severe thermal stress and may die if they do not seek shade or the cooler temperatures of burrows (Luckenbach 1981). The summer months associated with aestivation are June and July (Nagy and Medica 1986). Given the 1-month time-step, the model operates on the average monthly temperature, which doesn't reach 39.5 °C during the 20-year record, 1970-1990. Thus, estivation doesn't significantly influence tortoise behavior within the model.

When not hibernating, hatchling mortality is the sum of the proportion that die due to predation (we assume up to 32 percent) and natural causes, including inadequate food or water supply (constant at 10 percent in all cells). Based on the information that predation of young tortoises, and particularly hatchlings, tends to be higher than predation on adults (Luckenbach 1981), we assume predation is a more important mortality factor. Under the best conditions, a total of 85 percent of the hatchlings survive; under the worst conditions, a total of 58 percent survive. This gives some variation about the mean value of 79 percent used by Luke (1990), that we assume represents "average" to "good" conditions. This number differs greatly from previous estimates of 1 to 3 percent survival (Anonymous 1973 cited in Luke 1987). During hibernation, only 5 percent die due to other factors, such as disease (undocumented assumption). The experimental survival rate is a function of the following:

```

Ha_surv_exp = IF Hibernate = 1
  THEN (1 - H_Die_hib)^5
  ELSE (1 - H_Die_natl - H_Die_pred)^5

```

Note that the power function converts annual survival rates into stage-specific survival rates.

Using the same conversion principles outlined in the previous section, this equation then becomes the model survivorship function:

$$Ha\_Survive = EXP (LOGN (H\_surv\_exp) * (1 / Hatchling\_Time)).$$

Tortoises remain in the hatchling cohort until their shells completely ossify, which usually occurs when the tortoise is 5 years old (Luckenbach 1981). "Hatchling time" in the model is set accordingly. The reason for basing the "hatchling cohort" age-class division on the level of shell development is that a soft-shelled tortoise is much more vulnerable to predation than a tortoise with a hardened shell (Luckenbach 1981). For example, raven predation on desert tortoises is primarily restricted to hatchlings whose shells are less than 110 mm maximum carapace length; in other words, small tortoises with soft shells. So, higher mortality rates distinguish hatchlings from the next cohort — juveniles.

**Juveniles.** Tortoises remain in the juvenile cohort, "T JUVENILE", until they are lost either through juvenile mortality, represented by "Death J" or through recruitment to the adult cohort, represented by the outflow entitled "mature" (Figure 14).

Juvenile desert tortoises are those individuals who have ossified shells but who have not yet reached sexual maturity. Predation rates are lower in juveniles than hatchlings. Like the two preceding cohorts, the literature available doesn't offer substantial empirical descriptions of survivorship within the juvenile population. Again, survivorship within the model is based on our best assumptions. When not

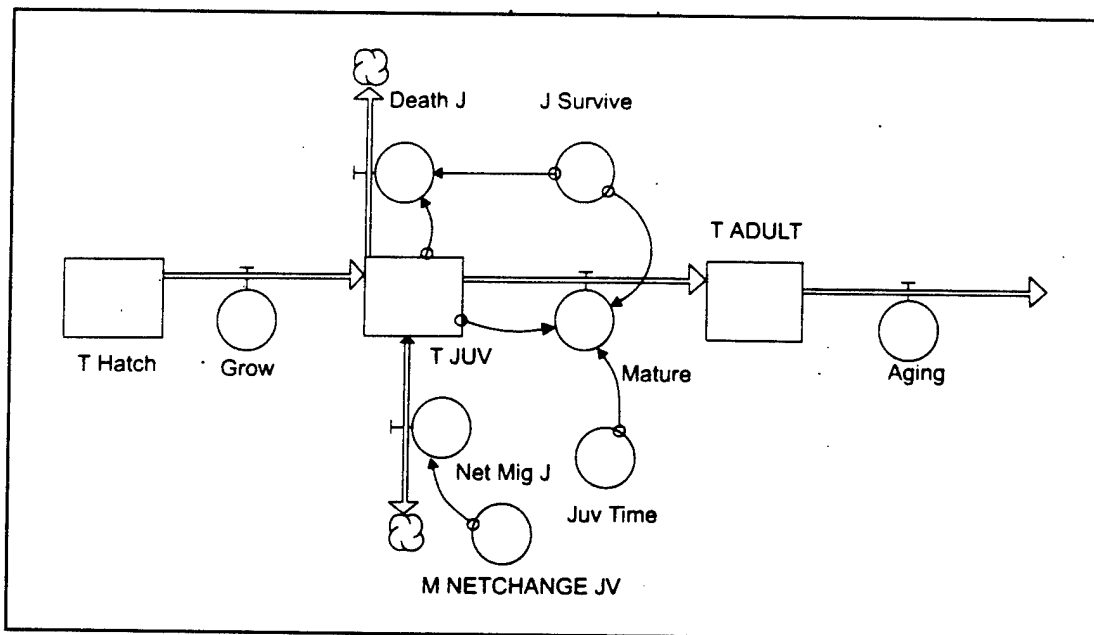

Figure 14. The juvenile cohort of the tortoise submodel.

hibernating, mortality is the sum of the proportion that die due to predation (we assume up to 22 percent), inadequate food (up to 4.4 percent), and inadequate water supply (up to 13.2 percent). We also have added a constant proportion of 1.7 percent of juveniles who die each month (regardless of the season) due to diseases (frequency of disease has been assumed to be density-independent in another model; see Luke 1990, p 256). Under best conditions, a total of 87.1 percent of juveniles survive and under worst condition a total of 38.9 percent survive. This gives some variation about the mean value of 83 percent used by Luke (1990), which we assume represents "average" to "good" conditions (thus much higher mortality can be observed in cells with "bad" conditions). During hibernation, a constant 2.7 percent die due to disease (1.7 percent) and other unknown factors (1 percent; undocumented).

```
J_surv_exp = IF Hibernate = 1
THEN (1 - J_Die_hib - J_Die_disease) ^ 17.5
ELSE (1 - J_Die_disease - J_Die_food - J_Die_pred - J_Die_water) ^ 17.5
```

Note that power function is included to change annual survival estimate into stage-specific survival.

The model survival rate is calculated using:

```
J_Survive = EXP (LOGN (J_surv_total) * (1/Juv_Time)).
```

Juveniles usually mature into adults sometime between the ages of 15 and 20, though it can take more or less time depending on habitat conditions (Woodbury and Hardy 1948). The model assumes an average juvenile time, "Juv Time," of 17.5 years. Juveniles enter the next cohort, adults, at 22.5 years of age.

**Adults.** The next stage in the desert tortoise life cycle is the adult cohort, represented in the model by the stock "T ADULT". As mentioned earlier, adults flow into this stock from the juvenile cohort through "mature", and they flow out either through losses due to adult mortality, represented by "Death RA" or through recruitment to the elders cohort, represented by the outflow entitled "Aging" (Figure 15).

Total adult mortality has been estimated to be between 1 and 2 percent per year (Luckenbach 1981; Turner et al. 1984), and as a result, is lower than the mortality of younger tortoises. Yet to complete the adult survivorship functions, we made assumptions about mortality based on predation, food and water supply, disease, and other natural causes. "Adult\_Survive" is calculated the same way as the juvenile survivorship rates. The only differences between the adult and juvenile rates are

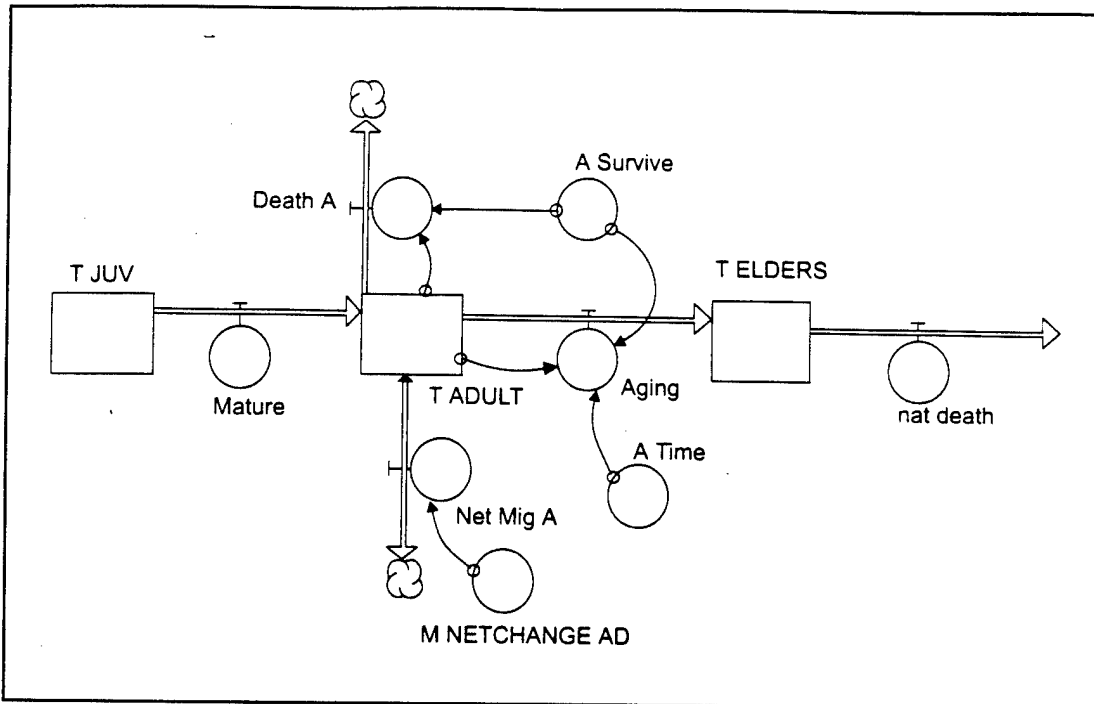

Figure 15. The adult cohort of the tortoise submodel.

that predation of juveniles is higher than adults. Tortoises remain adults until they reach 62.5 years old. All surviving adults older than 62.5 years move into the final cohort — elders.

**Elders.** The final stage in the desert tortoise life cycle is the elder cohort, represented in the model by the stock “T ELDERS”. This is the second adult cohort in the model. Adults flow into this stock through “aging” and flow out through mortality (Figure 16). The reason for dividing the adult population is to distinguish between those mature individuals who can reproduce, and those older tortoises who are reproducing but at a generally lower rate.

Elder survival, “Eld\_Survive”, is calculated the same way as adults and juvenile survivorship. In fact, elder survivorship uses the same mortality variables (predation, disease, food and water availability) used for the adult cohort.

```
Elder_surv_exp = IF Hibernate = 1
  THEN (1 - Adult_Die_hib_aest - Adult_Die_disease)^10
ELSE (1 - Adult_Die_disease - Adult_Die_food - Adult_Die_water -
  Adult_Die_pred)^10
```

The same conversion is used to transform this experimental survivorship rate into a rate appropriate for the model time-step of 1 month.

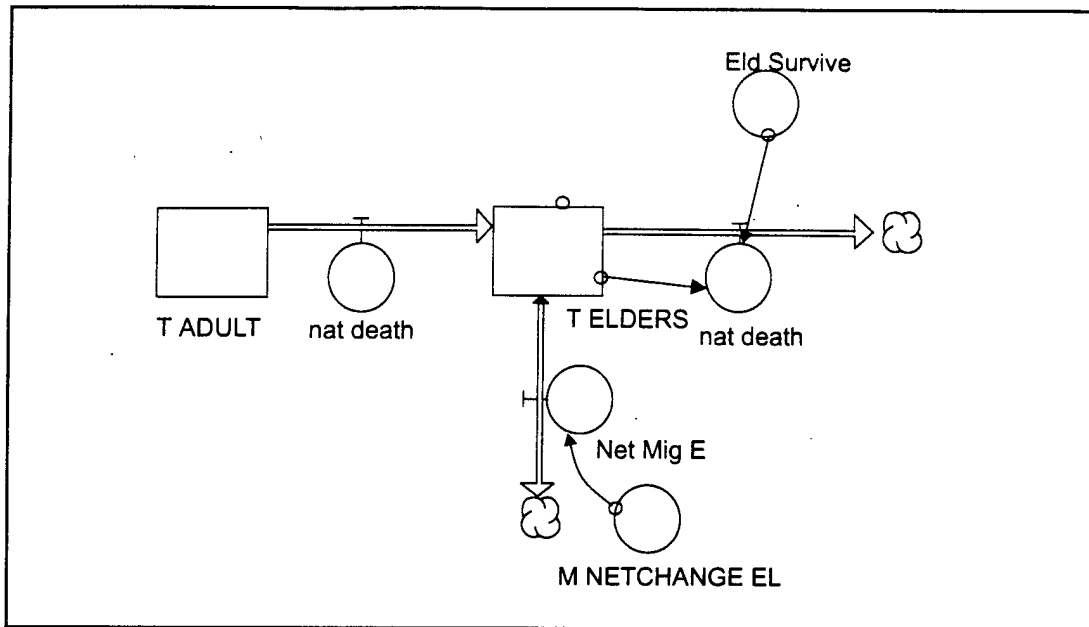

Figure 16. The elders cohort of the tortoise submodel.

In the model, elders can survive up to 10 years. The maximum age that can be reached by a tortoise in our model is about 75 years, which is supported by the literature on desert tortoises (Turner et al. 1984).

## Tortoise Dispersal Submodel

### *Purpose*

The purpose of the tortoise dispersal submodel is to simulate movements of tortoises between adjacent cells as well as calculate changes in juvenile, adult, and elder tortoise densities due to dispersal. Values generated in this submodel are used by the tortoise submodel to adjust tortoise densities within each cell.

### *Approach*

The general approach was to simulate juvenile, adult, and elder tortoise dispersal movements by designing a set of rules that dictate when and where tortoises move (Figure 17). The net change in the number of tortoises within a cell due to dispersal is the difference between the number of tortoises that emigrated and the number of tortoises that immigrated. Dispersal movements are restricted by three primary factors: hibernation, tortoise density, and cell conditions (vegetative cover and availability of green vegetation). Conditions of adjacent cells do not entice animals to emigrate from an acceptable cell. But, the condition of each adjacent cell, relative to the other three adjacent cells, determines the proportion of emigrants that

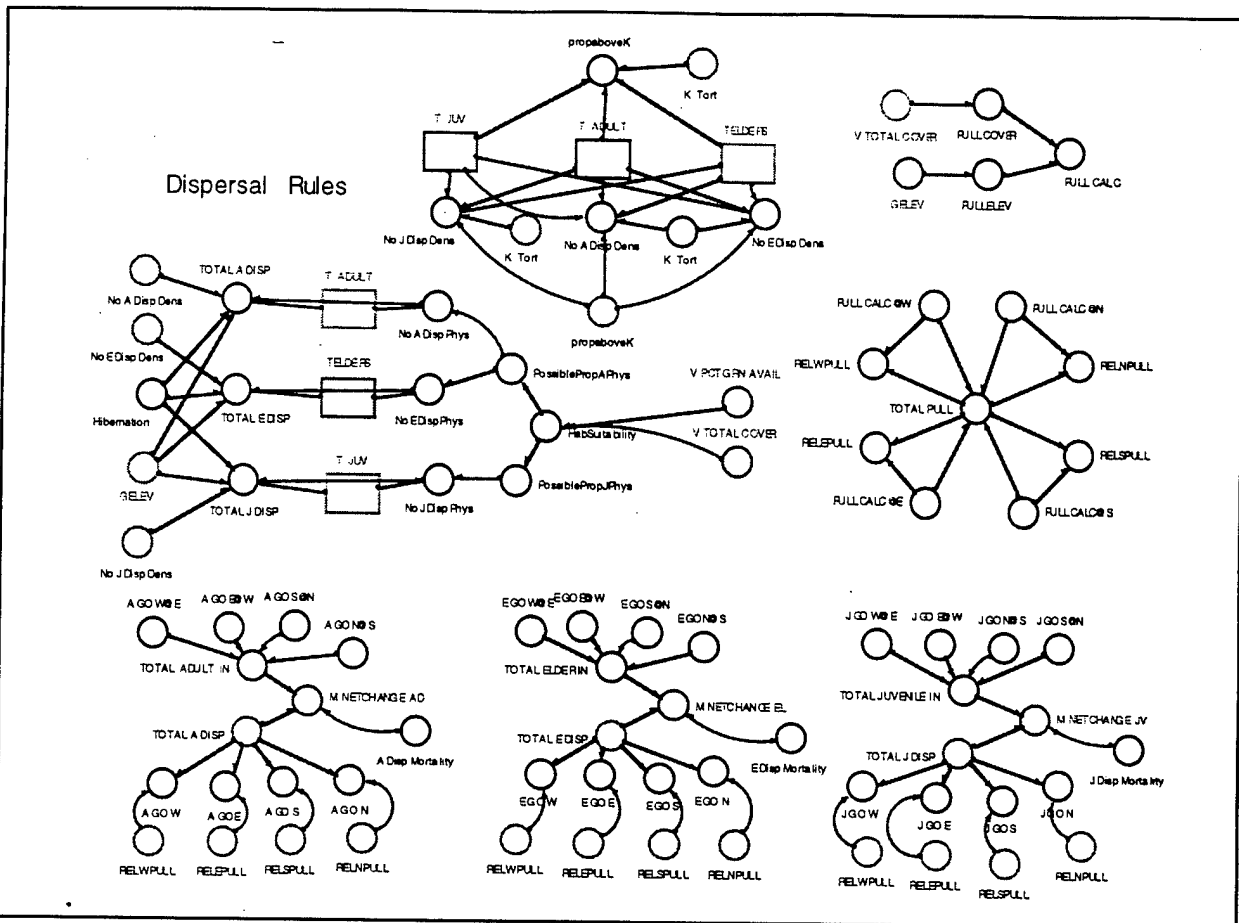

Figure 17. The dispersal submodel.

immigrate into that cell. The total number of tortoises immigrating into a cell is the sum of immigrants from each of four directions, and represents the number of animals that emigrate from adjacent cells into the cell of interest. Due to limitations in the available software, tortoises can only move the distance of one cell per time-step (1 km/month), and the direction of movement is restricted to the four cardinal directions (i.e., no diagonal movement).

### **Dispersal**

To date, no published study has investigated the long-range dispersal movements of desert tortoises. Given the importance of movement between populations or sub-populations to population genetics and long-term viability, more detailed studies are needed for threatened and endangered species such as the desert tortoise. Gibbons (1986) borrowed generalizations about dispersal in other turtles to infer causes of long-distance movements in desert tortoises. The following four behavioral and habitat conditions, documented in other turtles, each may contribute to dispersal in desert tortoises (Gibbons, 1986): (1) nest site selection, (2) seasonal migration, (3) departure from unfavorable habitat conditions, and (4) movement by males in search of females. The relative importance of each condition is unknown for many

turtle species; clearly, such information should be collected in order to manage threatened and endangered species more effectively.

As mentioned previously, the Desert Tortoise Model assumes that male and female tortoises are similar with regard to growth, reproduction, and survivorship; therefore, only females are modeled explicitly, and a 1:1 sex ratio is used (see "Desert Tortoise Submodel" section). Given this modeling structure, it was not possible to incorporate dispersal patterns due to movement by males in search of females. Also, the spatial resolution of 1 sq km limits the model's ability to describe potential nest site locations in detail. Burrows are often located in the walls of washes, but with a 1 sq km resolution, washes are too small to detect. Thus it is assumed that each cell can have multiple burrow sites, thus burrow sites do not specifically determine where tortoises migrate. Of the four conditions described above, two were incorporated into the model as incentives for dispersal, and it was assumed that both forces affected males and females equally: (1) seasonal migration and (2) departure from unfavorable habitat conditions.

Desert tortoises hibernate and aestivate to reduce physiological stresses associated with temperature extremes. However, as mentioned previously, the 1-month time-step precludes incorporating aestivation behavior, given that average monthly temperature data doesn't reveal the daily fluctuations of temperature extremes during the summer. For this reason, of those two behaviors, only hibernation significantly influences tortoise movement.

Tortoises emigrate from cells that have relatively low amounts of vegetative cover, low amounts of available green forage, and high tortoise densities. The first two factors are described with the converter "Hab\_suitability", the habitat suitability of a cell. This is an index (from 0 to 1) that determines the degree of "push" that forces a tortoise to leave a cell. The index is a function of the vegetation cover and the available food within the cell.

$$\text{Hab\_Suitability} = (\text{V\_PCT\_GRN\_AVAIL}/100) * (\text{V\_TOTAL\_COVER}/100)$$

As the function approaches zero, a larger number of tortoises move. These are the physical conditions that help determine if a tortoise will emigrate. Figure 18 shows the dispersal rules.

Tortoise density also affects the tortoise's desire to remain within a cell. Tortoises are not territorial, their home ranges do overlap, and they are social animals. Exactly how the social relations within the population work is not well known, and we found no published literature on the topic. Given that juveniles are younger and not reproducing, it was assumed that they were more mobile and less valued within

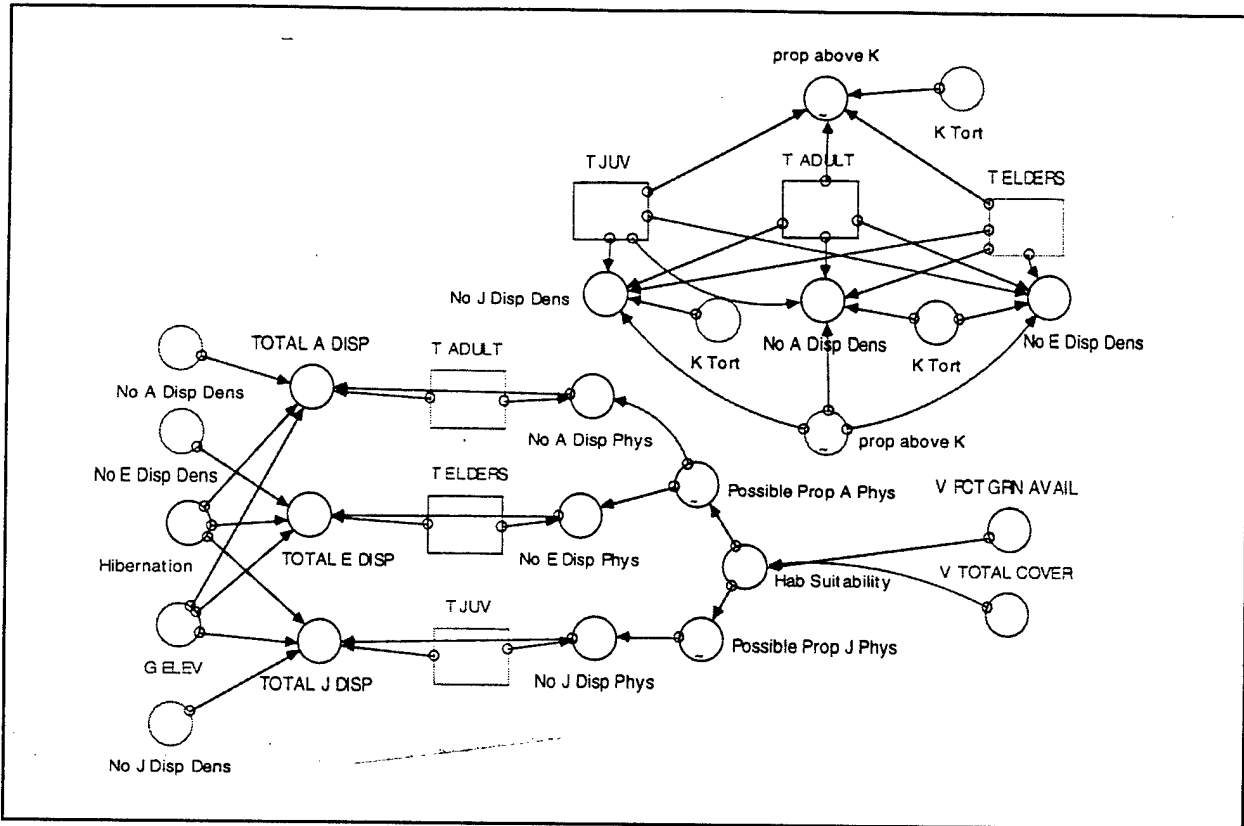

Figure 18. Tortoise dispersal rules.

the social structure. Thus, juveniles were more sensitive to densities. With an assumed tortoise carrying capacity, "K\_Tort", of 100 tortoises per square kilometer (that is 100 females, or 200 total tortoises), the proportion of juveniles, adults, and elders that dispersed due to population pressures were calculated with the following equations:

$$J\_Disp\_Dens = \text{If } (T\_ADULT + T\_ELDERS + T\_JUV) - K\_Tort > 0 \\ \text{then } 0.5 * ((T\_ADULT + T\_ELDERS + T\_JUV) - K\_Tort) \text{ else } 0$$

$$A\_Disp\_Dens = \text{If } (T\_ADULT + T\_ELDERS + T\_JUV) - K\_Tort > 0 \\ \text{then } 0.25 * ((T\_ADULT + T\_ELDERS + T\_JUV) - K\_Tort) \text{ else } 0$$

$$E\_Disp\_Dens = \text{If } (T\_ADULT + T\_ELDERS + T\_JUV) - K\_Tort > 0 \\ \text{then } 0.25 * ((T\_ADULT + T\_ELDERS + T\_JUV) - K\_Tort) \text{ else } 0$$

The two general push forces, habitat suitability and density, were then combined and augmented with the parameters of elevation and seasonality. If the elevation is above 1067 m (3500 ft) it's highly unlikely that one would find a tortoise in that environment, although there are anomalies. Physiological constraints may prevent tortoises from using high elevation areas, regardless of the availability of food and shelter. Additionally, if the tortoise is hibernating, then migration is assumed to not

occur. The total proportion of juveniles, adults, and elders that could emigrate from a cell is determined by this general equation:

Total Dispersion = If Hibernation = 1 then 0.0 else if G\_ELEV  $\geq$  3500  
then T\_ADULT (or T\_JUV or T\_ELDERS) else (A\_Disp\_Dens + A\_Disp\_Phys)

## 4 Results and Future Research

This technical report documents the design and development of a spatially explicit habitat and population model of the Desert Tortoise. A second report will extend the model by adding a training impacts component and will discuss the results of a series of experiments. These experiments will attempt to provide insights into the comparative impacts of different training intensities in time and in space. Current and potential training intensities will be compared to help identify strategies that preserve the training effectiveness of Fort Irwin while increasing the tortoise population viability.

An initial result established by running the entire model for 100 years on the entire landscape is presented in Figure 19. The model is initialized with tortoise and vegetation densities derived from measurements associated with current training intensities. The average tortoise density begins at 2.8 tortoise/sq km, drops to 1.1 and then rises to 4.1 at 100 years. This result appears to be associated with a decline in tortoise densities in some areas while other areas (currently supporting training) are repopulated and develop strong densities. Causes for the initial drop

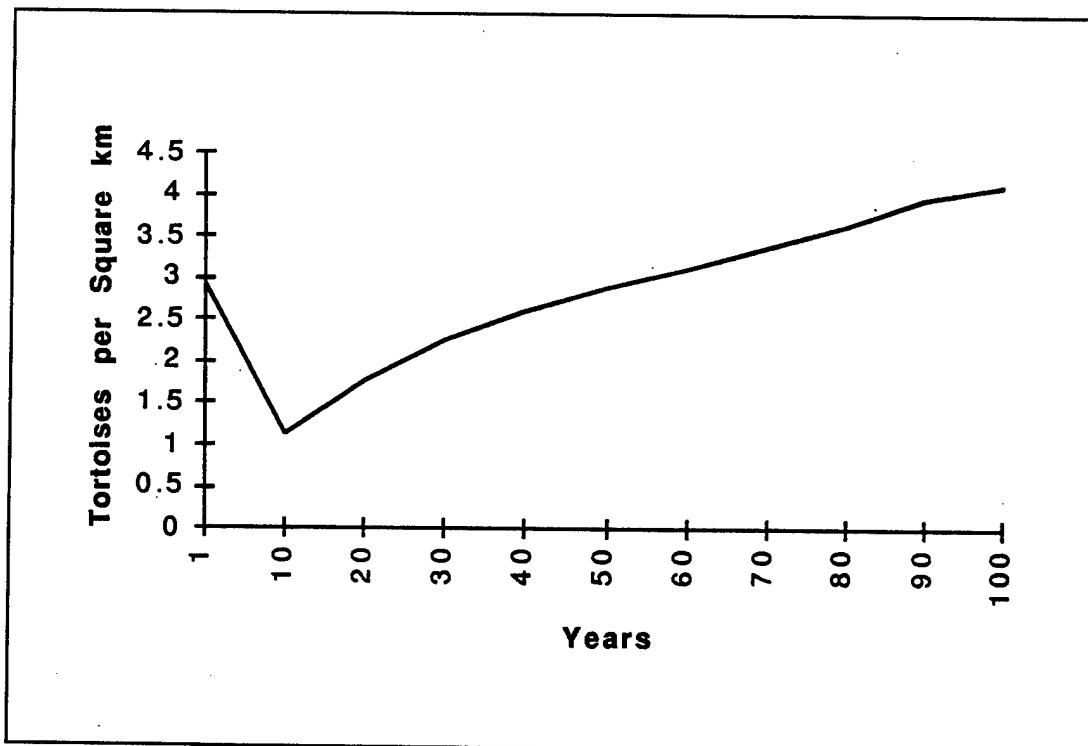

Figure 19. Projected tortoise density

need to be investigated. There are a number of independent possibilities. It is possible that the current population estimates are too high. This could be due to sampling error, error in estimation, or error in the application of the neural network used to convert transect population estimates to full-map coverage estimates. It is also possible that current training patterns have forced tortoises into areas that are not optimal for reproduction. As these tortoises die and are not replaced by juveniles, the population in these areas declines. It is certainly likely that our current lack of behavioral information about the tortoise and its movements in response to environmental characteristics contributes to the puzzle. Future experiments with the model will help address questions raised by Figure 19. Continuing sensitivity analyses will also be useful in analyzing the current model and the relationship of its various parameters to the behavior of the model.

### **The Proposed Sensitivity Analysis Approach**

The objective of sensitivity analysis (SA) of the spatially explicit model, the SME version, is to determine the degree to which manipulation of a certain factor, or some combination of factors, affects the results of the model. Because few other modelers have undertaken SA of complex, spatial models, a need exists to develop a novel approach that incorporates "traditional" SA of the single-cell model as well as "spatial" SA of the multiple-cell model.

The most scientific way to determine which factors have the greatest influence on results (the highest sensitivity) is by systematically testing each factor and all possible combinations of factors. There are two basic methods to use. The first involves using the same sensitivity perturbation in all affected cells, but varying the proportion of cells that are affected by the perturbation. The second approach involves the use of multivariate permutation tests that could be used to determine if two output maps were "significantly" different. Although these tests are relatively new, they are already available as computer programs and published in peer-reviewed journals (Reich and Czaplewski 1993).

### **Recommended Strategy**

This recommended approach determines the sensitivity of results to changes in single factors, and thus does not address factor interactions (so will not find "lethal combinations"). It combines the traditional SA techniques of varying the magnitude of perturbation to a factor ("% Factor Changed") as well as the spatial SA technique in which the number of cells affected by the perturbation is changed ("% Cells Affected"). Both factors are manipulated, and the resulting output can be tested to

determine if it is statistically different from output generated by the preperturbed model using multivariate tests. This SA would begin with primary factors (factors that are passed on to other sectors and state variables). If the model is stable to changes in these factors, there is no need to conduct SA on "contributing" variables. This analysis will also include nonempirically derived constants.

The magnitude of perturbation could be handled in the single-cell model by incorporating a "sensitivity factor" variable and making the factor of interest the product of the original value and the "sensitivity factor." The spatial component would be best managed by creating a "g\_sensitivity" map in GRASS (the Geographic Resources Analysis Support System), with each cell having one of two integers used to represent "affected" (e.g., 1) and "unaffected cells" (e.g., 0). The maps would be generated by randomly assigning "0" values to the correct proportion of cells. To incorporate the spatial component, the "sensitivity factor" in the single-cell model would need to be modified to:

```
IF g_sensitivity = 0
  THEN <original function>
ELSE sensitivity_factor * <original function>
```

A simple approach would probably suffice, such as changing five levels of "% Factor Changed" (0% change, 25, 50, 75, and 100% reduction) and five levels of "% Cells Affected" (0, 25, 50, 75, and 100% of cells). Of course, the unperturbed model is represented by any combination that involves either 0% Factor Changed or 0% Cells Affected, so there are really 4 levels for each manipulation and 16 possible combinations. It would probably be best to generate numerous random "g\_sensitivity" maps for each level of "% Cells Affected" (e.g., 5 different maps each with 25 percent of cells affected). Additionally, because this is a nondeterministic model it would probably be best to compare output from numerous runs of the same combination of SA conditions (e.g., 5 runs at 25% Factor Changed using Map 1 of 50% Cells Affected). Using this approach, 25 runs would be conducted for each of the 16 combinations, or a total of 400 runs for each factor.

For each factor, we could produce results as a graph indicating which combinations of the two types of manipulations produced significantly different results. One way to do this would be to present the mean P-value of the significance tests (mean of all 25 runs) for each of the 16 combinations of SA manipulation. As an example, consider the factor of interest to be Adult Survival; the output may look like Table 1 where each value represents the mean P-value of 25 runs.

The relative sensitivity of the model to each single factor could be found by comparing graphs produced for the factors of interest. The model would be

considered most sensitive to factors that have graphs in which statistical differences ( $P < 0.05$ ) occur at lower levels of “% Cells Affected” and “% Factor Changed” (i.e., towards the origin). It would also be possible to define a “curve” that defines the  $P = 0.05$  “contour” on each graph, but this would require conducting runs for a much larger number of combinations of manipulations.

An additional method for testing the model would be to use the coefficient of variation (“CV” =  $SD / \text{mean}$ ). The CV for a factor in the model could be compared with observed CVs from field studies or with results from other “accepted” simulation models found in the literature. For example, the CV of January temperature should be similar to CV for January temperature observed at nearby meteorological stations or with other models that simulate desert temperatures. Comparisons made at different temporal scales (such as monthly, yearly, 10-yr, 100-yr) would make this a more robust form of validation. Using CVs to validate the model is relatively easy for factors in the climate and vegetation submodels, but it will be much more difficult to find appropriate “reference” datasets for factors in the tortoise and migration submodels.

This degree of extensive validation and testing is both temporally and computationally intensive. Major funding needs to be devoted to this portion of the research project in order to proceed.

**Table 1. Sample Sensitivity Analysis Output**

% Factor Changed	% Cells Affected				
		25%	50%	75%	100%
100%		0.07*	0.05	0.001	0.001
75%		0.12	0.08	0.001	0.001
50%		0.42	0.24	0.04	0.001
25%		0.58	0.35	0.21	0.03

\*Each value represents the mean P-value of 25 runs.

## 5 Summary

This report documents the development of a dynamic, spatial, ecological simulation model of Desert Tortoise habitat and population densities on the Fort Irwin, CA, landscape. The model is intended to be useful in evaluating the direct, indirect, short-term, and long-term impacts of human activities on the habitat that supports Desert Tortoise populations.

Most models are developed for the purpose of scientifically understanding some component of the natural system. Such models are typically very precise and carefully assembled with respect to the component of the system being studied. Because they do not simulate all important components of a system, they have limited utility for making land management decisions. This Desert Tortoise habitat and population simulation model is developed to be part of a computer-based land management decision support system.

To create this simulation model, two graduate classes were assembled during the spring semesters of 1994 and 1995. During the following summers some students from the class were selected to further develop and refine the model. Students were drawn from a number of different departments including Geography; Forestry; Ecology, Ethology and Evolution; Computer Science; Urban and Regional Planning; and Anthropology.

Classes were divided into a number of teams. The classes, as wholes, outlined the final model and divided it into submodels that were then assigned to teams. Students applied their particular backgrounds and interests to the models that provided the best match. Four basic submodels emerged: climate, vegetation, tortoise growth, and tortoise migration.

This model uses three key software products. The initial conceptual and then the full unit model was designed and developed with a graphical dynamic simulation language called STELLA. The model specified the dynamics within 1 sq km cells of the Mojave Desert. Fort Irwin, California was gridded into a 57 by 57 grid of these cells. The geographical information system used to manipulate the spatial data was the Geographic Resource Analysis Support System (GRASS). The unit models developed using STELLA were then translated into C++ computer programs that applied the model simultaneously to each unit cell.

Development of this model should now be followed by further research to validate the model and to analyze the sensitivity of various portions of the model to varying input parameters and landscape states. This model was developed to address the anticipated changes in Desert Tortoise population densities expected from different land management scenarios. Because tortoise individuals can live more than 75 years, impacts can be associated with long lag periods. For example, initiating a land management practice that somehow stops tortoise reproduction will have disastrous effects on the population, but those impacts may not be noticed for a decade or more. This model must be sufficiently predictive over the course of at least 50 years and perhaps 100 years or more. Models predicting this far into the future suffer, as a whole, because of the obvious inability to field test the entire model. Instead, a sensitivity analysis should be run on the model to identify the model components to which the overall model is most sensitive. Those parameters, algorithms, or data must then be examined more thoroughly. Similarly, the sources of error and their cumulative impacts on the model should be understood and analyzed. Through these processes the reliability of the model can be increased.

The model should be used to evaluate and compare different land management scenarios. With the completion of a sensitivity and error analysis, the model outputs will, of course, be more reliable. Even without further analysis the model should be useful to assess the direction of change (if not the actual magnitude) in habitat suitability related to a particular change in management.

In a follow-up report, a number of experiments with the model will be reported. First, the model will be run on the installation with all human impacts (military training) removed. What vegetation patterns emerge? Are the vegetation densities similar to those found in undisturbed areas of the Mojave? Second, the model will be run on the landscape resulting from the first experiment with human activities similar to those currently occurring. Do the resulting patterns and densities match current conditions? Third, the training spatial patterns will be maintained, but the training intensity will be varied. How do steady-state population densities change with respect to training intensities? Fourth, the training temporal patterns will be varied. If training could be ceased for a full month, which month is associated with the greatest change in steady-state tortoise populations. Fifth, training patterns will be changed. Can corridors be created that result in significant changes in tortoise densities? The documented results of a number of different experiments will provide land managers with a scientific basis for encouraging or discouraging certain land management scenarios with respect to the Desert Tortoise and its habitat.

## References

- Abdul-Jabbar, A.S., Sammis, T.W., Lugg, D.G., Kallsen, C.E., and Smeal, D., 1983, "Water Use by Alfalfa, Maizze, and Barley As Influenced by Available Soil Water," *Agricultural Water Management*, vol 6, pp 351-363.
- Avery, H.W., 1992, "Summer Food Habits of Desert Tortoises in Ivanpah Valley, California," in K.R. Beaman, ed., *Desert Tortoise Council Symposium, 13* (Desert Tortoise Council).
- Beatley, J.C., 1974, "Phenological Events and Their Environmental Triggers in Mojave Desert Ecosystems," *Ecology*, vol 55, pp 856-863.
- Bedient, P.B., and Huber, W.C., 1992, *Hydrology and Floodplain Analysis*, 2nd edition (Reading, Massachusettes: Addison-Wesley Publishing Company).
- Berry, K.H., 1976, "A Comparison of Size Classes and Sex Ratios in Four Populations of the Desert Tortoise," in N.J. Engberg, ed., *Desert Tortoise Council Symposium 1* (Desert Tortoise Council).
- Dunning, J.B., Jr., Stewart, D.J., Danielson, B.J., Noon, B.R., Root, T.L., Lamberson, R.H., and Stevens, E.E., 1995, "Spatially Explicit Population Models: Current Forms and Future Uses," *Ecological Applications*, vol 5, no. 1, pp 3-11.
- Ernst, C.H., and Barbour, R.W., 1972, *Turtles of the United States* (Lexington: The University Press of Kentucky).
- Esque, T.C., 1994, *Diet and Diet Selection of the Desert Tortoise (Gopherus Agassizii) in the Northeast Mojave Desert*, Master of Science Thesis, Colorado State University.
- Evans, D.D., Sammis, T.W., and Cable, D.R., 1981, "Actual Evapotranspiration Under Desert Conditions," in D.D.E.a.J.L.T., eds., *Water in Desert Ecosystems* (Stroudsburg, PA.: Dowden, Hutchinson and Ross, Inc.), pp 195-218.
- Gibbons, J.W., 1986, "Movement Patterns Among Turtle Populations: Applicability to Management of the Desert Tortoise," *Herpetologica*, vol 42, pp 104-113.

- Goodall, D.W.,-1981, "The modelling of arid ecosystem dynamics," in D.W. Goodall and R.A. Perry, eds., *Arid-land ecosystems: structure, functioning and management* (Cambridge: Cambridge University Press), pp 385-410.
- Goran, W.D., Radke, L.L., and Severinghaus, W.D., 1983, *An overview of the ecological effects of tracked vehicles on major U.S. Army installations*, Technical Report N-142 (U.S. Army Construction Engineering Research Laboratories).
- Hannon, B., and Ruth, M., 1994, *Dynamic Modeling*, (New York: Springer-Verlag).
- Henen, B.T., 1992, "Desert Tortoise and Dietary Deficiencies Limiting Tortoise Egg Production at Goffs, California," in K.R. Beaman, ed., *Desert Tortoise Council Symposium, 13*, (Desert Tortoise Council).
- Hohman, J.P., Ohmart, R.D., and Schwartzmann, J., eds., 1980, *An Annotated Bibliography of the Desert Tortoise (Gopherus Agassizii)*, (Tempe, Arizona: Desert Tortoise Council).
- Inouye, R.S., 1991, "Population biology of desert annual plants," in G. A. Polis, ed., *The Ecology of Desert Communities* (Tucson: University of Arizona Press) pp 27-54.
- Jain, K., and Sinai, G., 1985, "Evapotranspiration Model for Semiarid Regions," *Journal of Irrigation and Drainage Engineering*, vol 111, no. 4, pp 369-379.
- Knapp, P.A., 1992, "Secondary plant succession and vegetation recovery in two western Great Basin Desert ghost towns," *Biological Conservation*, vol 60, no. 2, pp 81-89.
- Krzysik, A.J., in press, "Desert Tortoise Populations in the Mojave Desert and a Half-Century of Military Training Activities," in *Conservation, Restoration, and Management of Tortoises and Turtles - An International Symposium*, New York, NY.
- Landsat Technical Notes, no. 1, August 1986.
- Lane, L.J., Romney, E.M., and Hakonson, T.E., 1984, "Water balance calculations and net production of perennial vegetation in the northern Mojave Desert," *Journal of Range Management*, vol 37 (Jan 1984), pp 12-18.

- Luckenbach, R.A., 1981, "Ecology and Management of the Desert Tortoise in California," in R.B. Bury, ed., *North American Tortoises Conservation and Ecology* (U.S. Fish and Wildlife Service) pp 1-37.
- Luke, C., 1990, "A Population Model for the Desert Tortoise (*Gopherus Agassizii*)," in *Desert Tortoise Symposia* (Desert Tortoise Council), pp 250-262.
- Maxwell, T., and Costanza, Q., 1993, "Spatial Ecosystem Modeling in a Distributed Computational Environment," in *Concepts, Methods, and Policy for Sustainable Development*, J. Van den Berg and J. Straaten, eds. (Island Press).
- Maxwell, T., 1995, "Distributed Modular Spatial Ecosystem Modeling," URL <http://kabir.umd.edu/SMP/MVD/CO.html>.
- Medica, P.A., Bury, R.B., and Luckenbach, R. A., 1980, "Drinking and Construction of Water Catchments by the Desert Tortoise," *Herpetologica*, vol 36, no. 4, pp 301-304.
- Nagy, K.A., and Medica, P.A., 1986, "Physiological Ecology of Desert Tortoises in Southern Nevada," *Herpetologica*, vol 42, no. 1, pp 73-92.
- Prose, D.V., Metzger, S.K., and Wilshire, H.G., 1987, "Effects of substrate disturbance on secondary plant succession; Mojave Desert, California," *Journal of Applied Ecology*, vol 24, Apr 1987, pp 305-313.
- Pulliam, H.R., Dunning Jr., J.B., and Liu, J., 1992, "Population Dynamics in Complex Landscapes: A Case Study," *Ecological Applications*, vol 2, no. 2, pp 165-177.
- Reich, Robin and Czaplewski, L., 1993, "Expected Value and Variance of Moran's Bivariate Spatial Autocorrelation Statistic for a Permutation Test," Research Paper RM-309 (Rocky Mountain Forest and Range Experiment Station, United States Department of Agriculture).
- Ricklefs, Robert E., 1990, *Ecology*, 3rd Edition (W. H. Freeman).
- Salih, A.M., and Uygur Sendil, 1983, "Evapotranspiration Under Extremely Arid Climates," *Journal of Irrigation and Drainage Engineering*, vol 110, no. 3, pp 289-303 (bibliography pp 301-2).

- Salih, A.M.A. and Solaimen, A. Al-Sha'lan, 1987, "Evapotranspiration Estimates in Extremely Arid Areas; Discussion," *Journal of Irrigation and Drainage Engineering*, vol 115, pp 907-912.
- Sammis, T.W., Williams, S., Sneal, D., and Kallson, C.E., 1986, "Effect of Soil Moisture Stress on Leaf Area Index, Evapotranspiration, and Modeled Soil Evaporation and Transpiration," *Transactions of the American Society of Agricultural Engineers*, vol 29, pp 956-961.
- Schlesinger, W.H., and Jones, C.S., 1984, "The Comparative Importance of Overland Runoff and Mean Annual Rainfall to Shrub Communities of the Mojave Desert," *Bot. Gaz.*, vol 145, no. 1, pp 116-124.
- Thornthwaite, C.W., 1948, "An Approach Toward a Rational Classification of Climate," *Geographical Review*, vol 38, pp 55 - 94.
- Thornwaite, C.W. and Mather, J.R., 1955, "The Water Balance," Drexel Institute of Technology, Laboratory of Climatology, Centerton, NJ, *Climatology*, vol 8, no. 1.
- Turner, F.B., Berry, K.H., Burge, B.L., Hayden, P., Nicholson, L., and Bickett, J., 1984, "Population Ecology of the Desert Tortoise at Goffs, San Bernadino County, California," in *Desert Tortoise Symposium, 9*, (Lake Havasu City, Arizona: Desert Tortoise Council), pp 68-82.
- Turner, M.G., Arthaud, G.J., Engstrom, R.T., Heil, S.J., Liu, J., Loeb, S., and McKelvey, K., 1995, "Usefulness of Spatially Explicit Population Models in Land Management," *Ecological Applications*, vol 5, no. 1, pp 12-16.
- Visocky, Adrian P. and Sherril, Marvin G., 1985, *Geology, Hydrology, and Water Quality of the Cambrian and Orovician Systems in IL* (Champaign, IL).
- Wallace, A., Romney, E.M., and Hunter, R.B., 1980, "The challenge of a desert: revegetation of disturbed desert lands," *Great Basin Naturalist Memoirs*, 4.
- West, F.W., 1979, "Plant processes: germination and seedling behavior," in D.W. Goodall and R.A. Perry, eds., *Arid-land ecosystems: structure, functioning and management* (Cambridge: Cambridge University Press) pp 477-490.
- West, N.E., 1983, "Overview of North American temperate deserts and semi-deserts," in N.E. West, ed., *Temperate deserts and semi-deserts* (Amsterdam: Elsevier Scientific Publishing Company) pp 321-330.

- Westervelt, J. et al., 1995, *Dynamic, Spatial, Ecological Modeling: Demonstrated Simulation of the Sage Grouse Habitat at the Yakima Training Center, Washington* USACERL Technical Report 95/16 (U.S. Army Construction Engineering Research Laboratories).
- Whitford, W.G., 1986, "Decomposition and nutrient cycling in deserts," in W.G. Whitford, ed., *Patterns and processes in desert ecosystems* (Albuquerque: University of New Mexico Press) pp 93-118.
- Woodbury, A.M., and Hardy, R., 1948, "Studies of the Desert Tortoise, *Gopherus Agassizii*, in the Mojave Desert," *Ecological Monographs*, 18, pp 145-200.
- Wu, X., and Westervelt, J., 1994, *Using Neural Networks To Correlate Satellite Imagery and Ground-truth Data* USACERL Technical Report EC-94/28 (U.S. Army Construction Engineering Research Laboratories).
- Zak, J.C., and Freckman, D.W., 1991, "Soil communities in deserts: microarthropods and nematodes," in G.A. Polis, ed., *The ecology of desert communities* (Tucson: The University of Arizona Press) pp 55-88.

## **Appendix: Full Model**



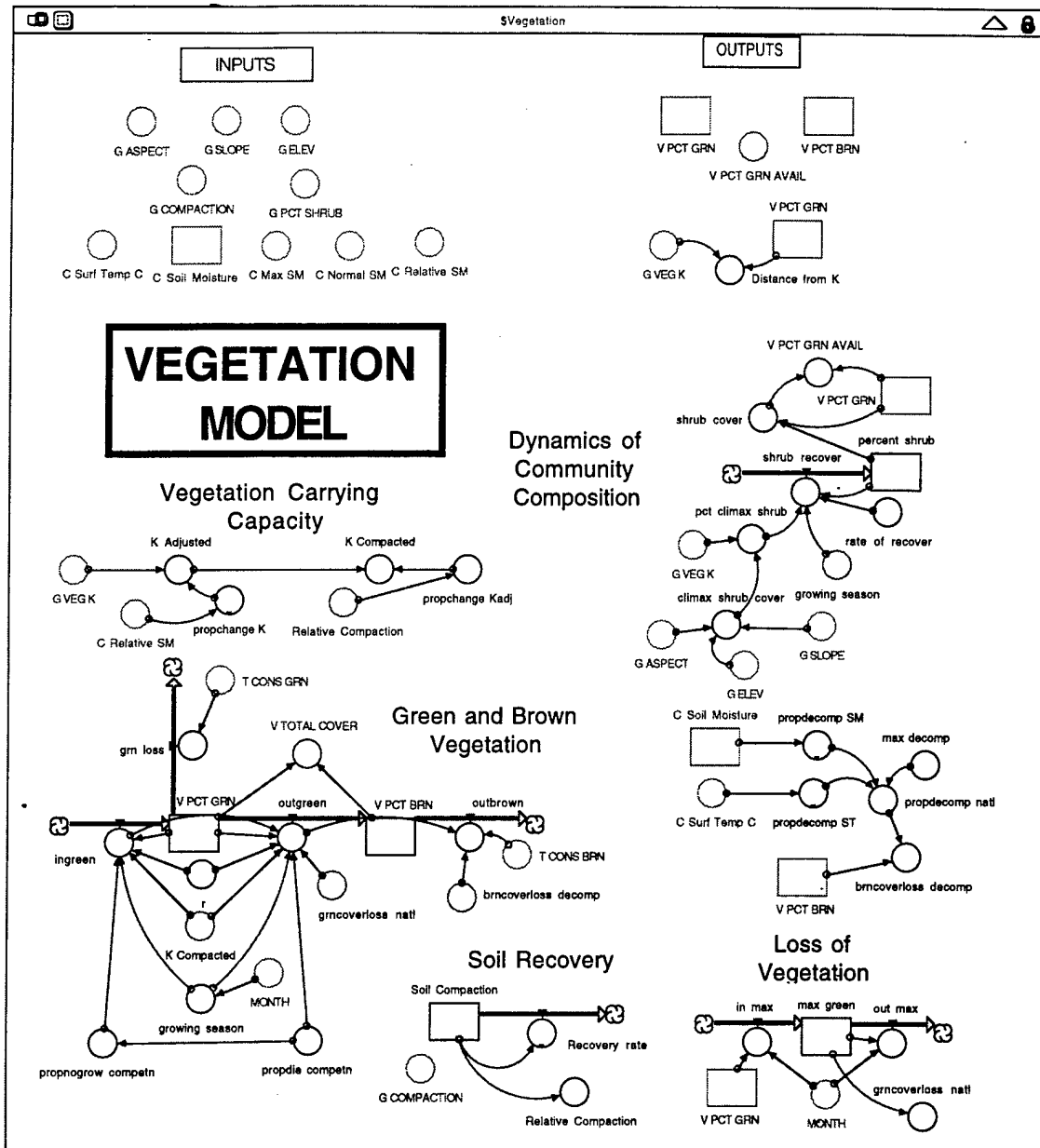

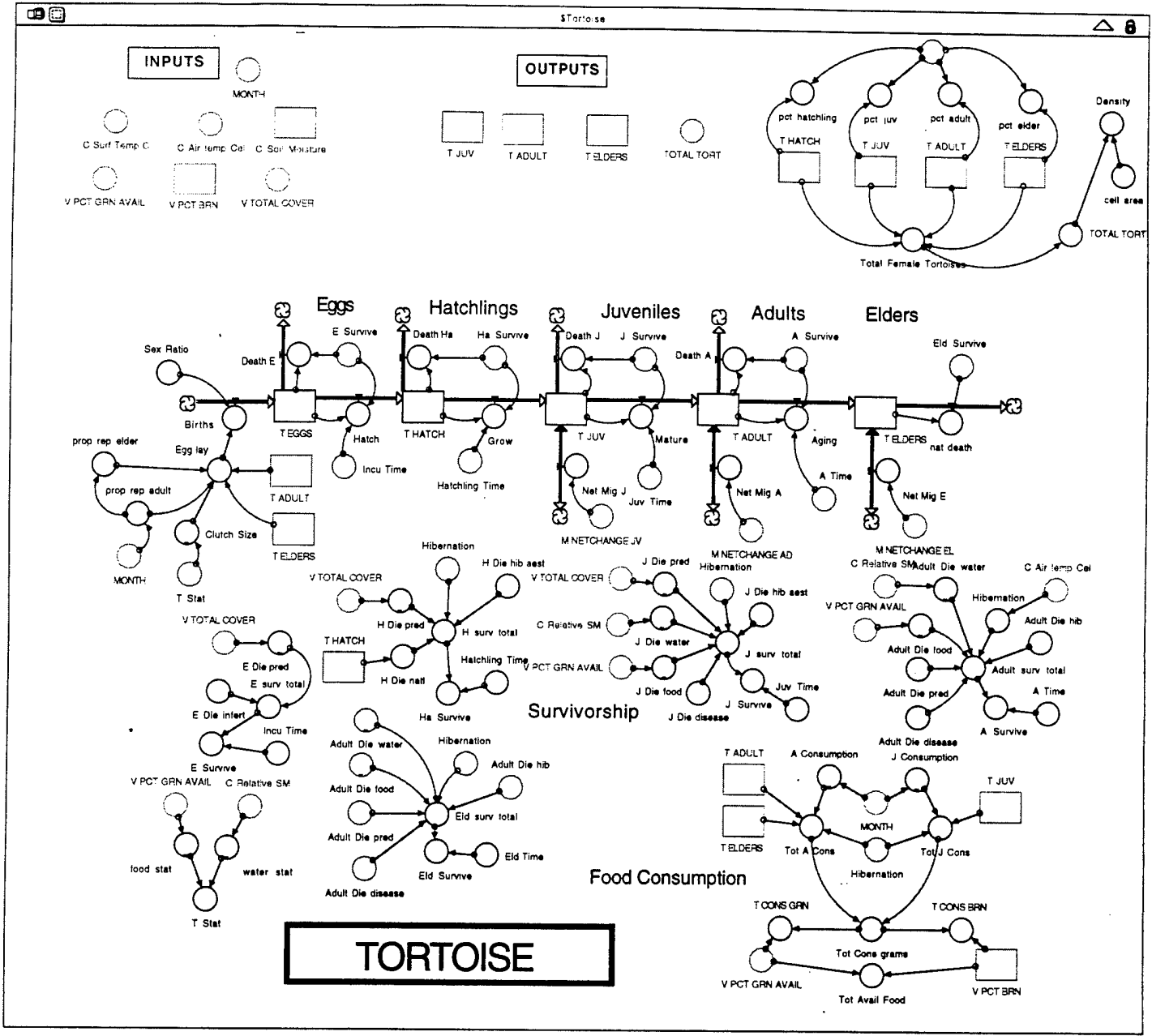

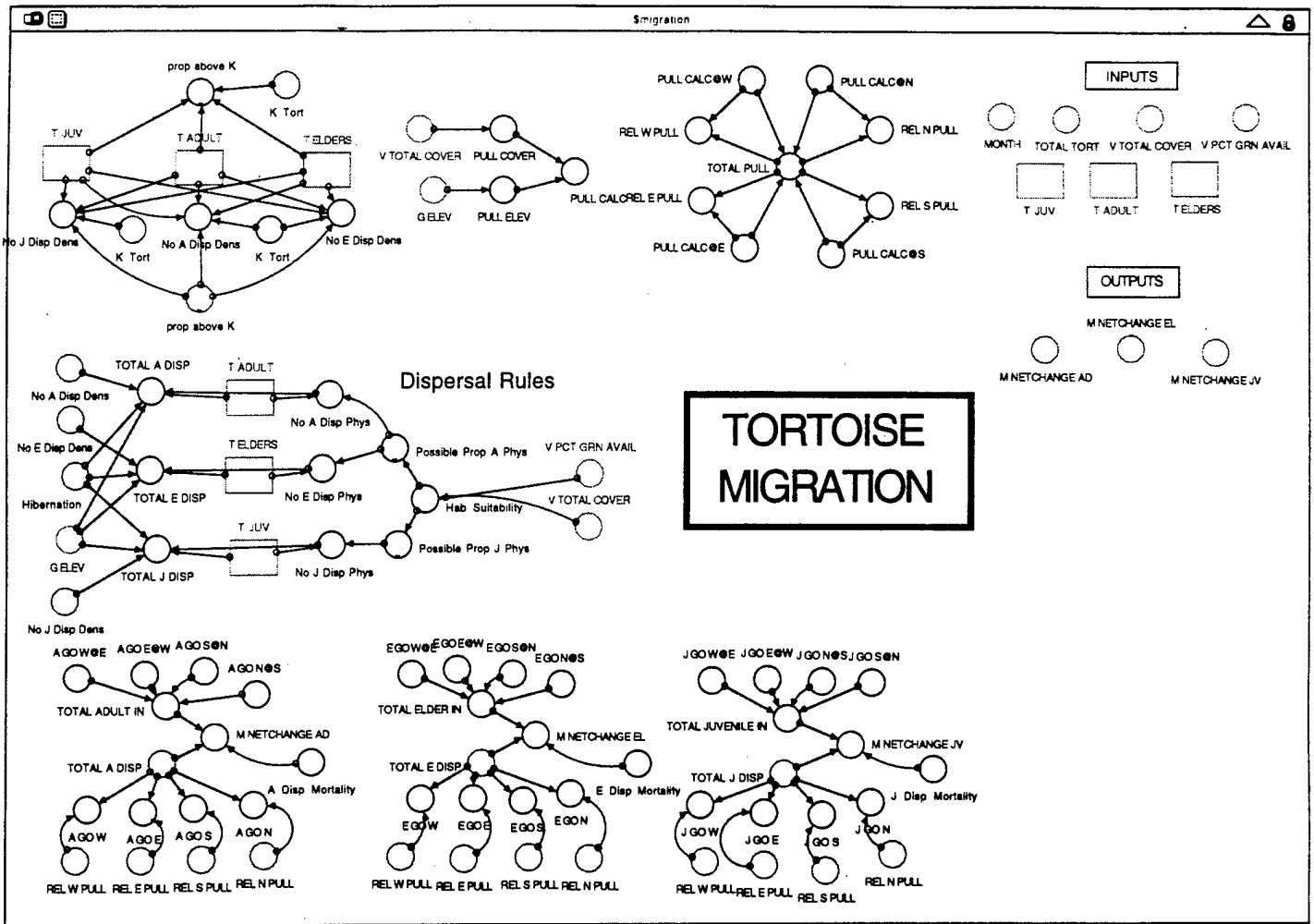

## Climate Sub-Model

C\_Soil\_Moisture(t) = C\_Soil\_Moisture(t - dt) + (Delta\_SM) \* dt  
 INIT C\_Soil\_Moisture = G\_INIT\_SM

Delta\_SM = If Unchecked\_DSM > (AWC-C\_Soil\_Moisture) Then INT(AWC-C\_Soil\_Moisture)  
 Else If Unchecked\_DSM < (-1)\*(C\_Soil\_Moisture) then INT((-1)\*(C\_Soil\_Moisture))  
 Else INT(Unchecked\_DSM)

AWC = (G\_AWC\_per\_inch/100)\*Depth\_of\_interest

Base\_elevation = 2105

Cos\_z = (COS(latitude)\*COS(rad\_slope) -  
 SIN(latitude)\*COS(rad\_aspect)\*SIN(rad\_slope))\*COS(solar\_dec) +  
 (COS(latitude)\*COS(rad\_aspect)\*SIN(rad\_slope) +  
 SIN(latitude)\*COS(rad\_slope))\*SIN(solar\_dec)

C\_Air\_temp\_Cel = (C\_Air\_temp\_Frh-32)/1.8

C\_Air\_temp\_Frh = IF z >= 0 THEN MMTemp + (Base\_elevation -  
 G\_ELEV)\*lapse\_rate/1000 - tau\*2\*(Cos\_z-COS(solar\_dec))  
 ELSE MMTemp + (Base\_elevation - G\_ELEV)\*(lapse\_rate/1000) - tau

C\_Max\_SM = max(G\_JAN\_SM, G\_FEB\_SM)

C\_MONTHLY\_PRECIP = If C\_Deterministic = 0 THEN  
 MAX(NORMAL(Precip\_Normals, (0.5\*Precip\_Normals+ 0.2\*Precip\_st\_devs)), 0.0)  
 \*25.4 ELSE Precip\_Normals\*25.4

C\_Normal\_SM = IF MONTH=0 THEN G\_JAN\_SM ELSE IF MONTH=1 THEN  
 G\_FEB\_SM ELSE IF MONTH=2 THEN G\_MAR\_SM ELSE IF MONTH=3 THEN  
 G\_APR\_SM ELSE IF MONTH=4 THEN G\_MAY\_SM ELSE IF MONTH=5 THEN  
 G\_JUN\_SM ELSE IF MONTH=6 THEN G\_JUL\_SM ELSE IF MONTH=7 THEN  
 G\_AUG\_SM ELSE IF MONTH=8 THEN G\_SEP\_SM ELSE IF MONTH=9 THEN  
 G\_OCT\_SM ELSE IF MONTH=10 THEN G\_NOV\_SM ELSE IF MONTH=11 THEN  
 G\_DEC\_SM ELSE 999

C\_Relative\_SM = IF C\_Soil\_Moisture < 1.0 AND C\_Normal\_SM < 1.0 THEN 1.0 ELSE  
 C\_Soil\_Moisture / MAX(C\_Normal\_SM,1.0)

C\_Surf\_Temp\_C = ((C\_SURF\_TEMP\_F-32)/1.8)

C\_SURF\_TEMP\_F = IF z >= 0 THEN (MMMTemp + (Base\_elevation -  
 G\_ELEV)\*lapse\_rate/1000 - tau\*2\*(Cos\_z-COS(solar\_dec)))  
 ELSE (MMMTemp + (Base\_elevation - G\_ELEV)\*lapse\_rate/1000 - tau)

date = 30\*MONTH+15

Depth\_of\_interest = 30 \* 10

lapse\_rate = 2.9

latitude =  $34 * \text{PI} / 180$

MMTemp = IF C\_Deterministic=0 THEN  
 MMTemp + NORMAL(Barstow\_Temp\_halfrange\_Normals,  
 Barstow\_Temp\_halfrange\_st\_devs,4322)  
 ELSE MMTemp + Barstow\_Temp\_halfrange\_Normals

MMTemp = IF C\_Deterministic=0 THEN  
 NORMAL(Barstow\_Temp\_Normals,Barstow\_Temp\_st\_devs,4322)  
 ELSE Barstow\_Temp\_Normals

PET\_mm = IF (C\_Air\_temp\_Cel>0) Then  
 $(1.6 * (10 * \text{C\_Air\_temp\_Cel} / \text{TH\_i})^{\text{TH\_a}}) * \text{PET\_factor} * 10$   
 ELSE 0

Potential\_Infiltration = If (MONTH > 9 or MONTH < 5) THEN C\_MONTHLY\_PRECIP  
 ELSE  $0.4 * \text{C\_MONTHLY\_PRECIP}$

rad\_aspect =  $\text{G\_ASPECT} * \text{PI} / 180$

rad\_slope =  $\text{G\_SLOPE} * \text{PI} / 180$

Runoff = If Potential\_Infiltration > AWC-C\_Soil\_Moisture then C\_MONTHLY\_PRECIP-  
 (AWC-C\_Soil\_Moisture)  
 else C\_MONTHLY\_PRECIP-Potential\_Infiltration

solar\_dec =  $(\text{PI} / 180) * 23.5 * \text{COS}(2 * \text{PI} * (\text{date} - 172) / 365)$

tau = 6.68

TH\_a = 1.926

TH\_i = 87.71

Unchecked\_DSM = IF (C\_Soil\_Moisture/AWC) <= 0.5 THEN  
 $(\text{Potential\_Infiltration} - \text{C\_Soil\_Moisture} * \text{PET\_mm} / \text{AWC}) / (1 + (\text{PET\_mm} / (2 * \text{AWC})))$   
 ELSE Potential\_Infiltration - PET\_mm

$z = \text{ARCTAN}(\text{SQRT}(1 - (\text{Cos\_z} * \text{Cos\_z}))) / \text{Cos\_z}$

Barstow\_Temp\_halfrange\_Normals = GRAPH(MONTH)  
 (0.00, 14.3), (1.00, 15.1), (2.00, 15.0), (3.00, 16.1), (4.00, 16.7), (5.00, 17.5), (6.00,  
 17.5), (7.00, 17.1), (8.00, 17.0), (9.00, 16.7), (10.0, 15.1), (11.0, 14.3)

Barstow\_Temp\_halfrange\_st\_devs = GRAPH(MONTH)  
 (0.00, 2.27), (1.00, 2.11), (2.00, 1.90), (3.00, 1.72), (4.00, 1.24), (5.00, 1.56), (6.00,  
 0.98), (7.00, 0.98), (8.00, 1.95), (9.00, 1.88), (10.0, 1.84), (11.0, 2.71)

Barstow\_Temp\_Normals = GRAPH(MONTH)  
 (0.00, 45.9), (1.00, 50.5), (2.00, 54.8), (3.00, 61.0), (4.00, 69.2), (5.00, 78.1), (6.00,  
 84.9), (7.00, 82.8), (8.00, 76.4), (9.00, 65.5), (10.0, 53.1), (11.0, 45.7)

Barstow\_Temp\_st\_devs = GRAPH(MONTH)

(0.00, 2.31), (1.00, 2.51), (2.00, 2.74), (3.00, 4.15), (4.00, 2.58), (5.00, 2.19), (6.00, 2.06), (7.00, 2.21), (8.00, 2.75), (9.00, 3.64), (10.0, 2.51), (11.0, 2.60)

PET\_factor = GRAPH(MONTH)

(0.00, 0.86), (1.00, 0.84), (2.00, 1.03), (3.00, 1.10), (4.00, 1.22), (5.00, 1.23), (6.00, 1.25), (7.00, 1.17), (8.00, 1.03), (9.00, 0.97), (10.0, 0.85), (11.0, 0.83)

Precip\_Normals = GRAPH(MONTH)

(0.00, 1.02), (1.00, 0.99), (2.00, 1.10), (3.00, 0.2), (4.00, 0.19), (5.00, 0.00), (6.00, 0.26), (7.00, 0.71), (8.00, 0.4), (9.00, 0.16), (10.0, 0.27), (11.0, 0.54)

Precip\_st\_devs = GRAPH(MONTH)

(0.00, 0.86), (1.00, 1.12), (2.00, 1.04), (3.00, 0.28), (4.00, 0.31), (5.00, 0.01), (6.00, 0.36), (7.00, 0.98), (8.00, 0.65), (9.00, 0.35), (10.0, 0.34), (11.0, 0.71)

## Tortoise Migration Sub-Model

A\_Disp\_Mortality = 0.2

A\_GO\_E = TOTAL\_A\_DISP \* REL\_E\_PULL

A\_GO\_E@W = 0

A\_GO\_N = TOTAL\_A\_DISP \* REL\_N\_PULL

A\_GO\_N@S = 0

A\_GO\_S = TOTAL\_A\_DISP \* REL\_S\_PULL

A\_GO\_S@N = 0

A\_GO\_W = TOTAL\_A\_DISP \* REL\_W\_PULL

A\_GO\_W@E = 0

E\_Disp\_Mortality = 0.5

E\_GO\_E = TOTAL\_E\_DISP \* REL\_E\_PULL

E\_GO\_E@W = 0

E\_GO\_N = TOTAL\_E\_DISP \* REL\_N\_PULL

E\_GO\_N@S = 0

E\_GO\_S = TOTAL\_E\_DISP \* REL\_S\_PULL

E\_GO\_S@N = 0

E\_GO\_W = TOTAL\_E\_DISP \* REL\_W\_PULL

E\_GO\_W@E = 0

Hab\_Suitability = (V\_PCT\_GRN\_AVAIL/100) \* (V\_TOTAL\_COVER/100)

J\_Disp\_Mortality = 0.5

J\_GO\_E = TOTAL\_J\_DISP \* REL\_E\_PULL

J\_GO\_E@W = 0

J\_GO\_N = TOTAL\_J\_DISP \* REL\_N\_PULL

J\_GO\_N@S = 0

J\_GO\_S = TOTAL\_J\_DISP \* REL\_S\_PULL

J\_GO\_S@N = 0

J\_GO\_W = TOTAL\_J\_DISP \* REL\_W\_PULL

J\_GO\_W@E = 0

K\_Tort = 100

M\_NETCHANGE\_AD = TOTAL\_A\_DISP - (A\_Disp\_Mortality \* TOTAL\_ADULT\_IN)

M\_NETCHANGE\_EL = TOTAL\_E\_DISP - (E\_Disp\_Mortality \* TOTAL\_ELDER\_IN)

$M\_NETCHANGE\_JV = TOTAL\_J\_DISP - (J\_Disp\_Mortality * TOTAL\_JUVENILE\_IN)$

$No\_A\_Disp\_Dens = IF (T\_ADULT + T\_ELDERS + T\_JUV) - K\_Tort > 0 THEN$   
 $prop\_above\_K * ((T\_ADULT + T\_ELDERS + T\_JUV) - K\_Tort) ELSE 0$

$No\_A\_Disp\_Phys = \{Prop\_Unk\_Disp +\} Possible\_Prop\_A\_Phys * T\_ADULT$

$No\_E\_Disp\_Dens = IF (T\_ADULT + T\_ELDERS + T\_JUV) - K\_Tort > 0 THEN$   
 $prop\_above\_K * ((T\_ADULT + T\_ELDERS + T\_JUV) - K\_Tort) ELSE 0$

$No\_E\_Disp\_Phys = \{Prop\_Unk\_Disp +\} Possible\_Prop\_A\_Phys * T\_ELDERS$

$No\_J\_Disp\_Dens = IF (T\_ADULT + T\_ELDERS + T\_JUV) - K\_Tort > 0 THEN$   
 $prop\_above\_K * ((T\_ADULT + T\_ELDERS + T\_JUV) - K\_Tort) ELSE 0$

$No\_J\_Disp\_Phys = Possible\_Prop\_J\_Phys * T\_JUV$

$Prop\_Unk\_Disp = 0$

$PULL\_CALC = PULL\_ELEV * PULL\_COVER$

$PULL\_CALC@E = 1$

$PULL\_CALC@N = 1$

$PULL\_CALC@S = 1$

$PULL\_CALC@W = 1$

$PULL\_COVER = V\_TOTAL\_COVER/100$

$PULL\_ELEV = MAX(0.0, (1-(G\_ELEV/3500)))$

$TOTAL\_ADULT\_IN = A\_GO\_E@W+A\_GO\_N@S+A\_GO\_S@N+A\_GO\_W@E$

$TOTAL\_A\_DISP = IF Hibernation = 1 THEN 0.0 ELSE$   
 $IF G\_ELEV >= 3500 THEN T\_ADULT ELSE$   
 $(No\_A\_Disp\_Dens + No\_A\_Disp\_Phys)$

$TOTAL\_ELDER\_IN = E\_GO\_E@W+E\_GO\_N@S+E\_GO\_S@N+E\_GO\_W@E$

$TOTAL\_E\_DISP = IF Hibernation = 1 THEN 0.0 ELSE$   
 $IF G\_ELEV >= 3500 THEN T\_ELDERS ELSE$   
 $(No\_E\_Disp\_Dens + No\_E\_Disp\_Phys)$

$TOTAL\_JUVENILE\_IN = J\_GO\_E@W+J\_GO\_N@S+J\_GO\_S@N+J\_GO\_W@E$

$TOTAL\_J\_DISP = IF Hibernation = 1 THEN 0.0 ELSE$   
 $IF G\_ELEV >= 3500 THEN T\_JUV ELSE$   
 $(No\_J\_Disp\_Dens + No\_J\_Disp\_Phys)$

$TOTAL\_PULL =$

$PULL\_CALC@W+PULL\_CALC@S+PULL\_CALC@N+PULL\_CALC@E$

$Possible\_Prop\_A\_Phys = GRAPH(Hab\_Suitability)$

$(0.00, 1.00), (0.1, 0.105), (0.2, 0.045), (0.3, 0.02), (0.4, 0.02), (0.5, 0.015), (0.6,$   
 $0.015), (0.7, 0.01), (0.8, 0.01), (0.9, 0.005), (1, 0.00)$

$Possible\_Prop\_J\_Phys = GRAPH(Hab\_Suitability)$

(0.00, 1.00), (0.1, 0.105), (0.2, 0.045), (0.3, 0.02), (0.4, 0.02), (0.5, 0.015), (0.6, 0.015), (0.7, 0.01), (0.8, 0.01), (0.9, 0.005), (1.00, 0.00)

prop\_above\_K = GRAPH(((T\_ADULT+T\_ELDERS+T\_JUV) - K\_Tort)/K\_Tort)  
 (0.00, 0.00), (0.12, 0.03), (0.24, 0.07), (0.36, 0.125), (0.48, 0.185), (0.6, 0.255),  
 (0.72, 0.325), (0.84, 0.41), (0.96, 0.515), (1.08, 0.655), (1.20, 0.995)

### Tortoise Growth Sub-Model

T\_ADULT(t) = T\_ADULT(t - dt) + (Mature - Aging - Death\_A - Net\_Mig\_A) \* dt  
 INIT T\_ADULT = G\_ADULT

Mature = IF TIME = 0 THEN 0 ELSE max(0.0, (J\_Survive\*(1/Juv\_Time)\*T\_JUV))  
 {adult recruitment per dt per cell}

Aging = IF TIME = 0 THEN 0 ELSE max(0.0, (A\_Survive\*(1/A\_Time)\*T\_ADULT))  
 {rate of elder recruitment per dt per cell}

Death\_A = IF TIME = 0 THEN 0 ELSE max(0.0, ((1-A\_Survive)/DT) \* T\_ADULT)

Net\_Mig\_A = IF TIME = 0 THEN 0 ELSE M\_NETCHANGE\_AD

T\_EGGS(t) = T\_EGGS(t - dt) + (Births - Hatch - Death\_E) \* dt

INIT T\_EGGS = 0

Births = Egg\_lay \* Sex\_Ratio

Hatch = IF TIME = 0 THEN 0 ELSE max(0.0, (E\_Survive \* (1 / Incu\_Time) \* T\_EGGS))

Death\_E = IF TIME = 0 THEN 0 ELSE max(0.0, (1-E\_Survive) \* T\_EGGS)

T\_ELDERS(t) = T\_ELDERS(t - dt) + (Aging - nat\_death - Net\_Mig\_E) \* dt  
 INIT T\_ELDERS = G\_ELDER

Aging = IF TIME = 0 THEN 0 ELSE max(0.0, (A\_Survive\*(1/A\_Time)\*T\_ADULT))  
 {rate of elder recruitment per dt per cell}

nat\_death = IF TIME = 0 THEN 0 ELSE max(0.0, (1 - Eld\_Survive) \* T\_ELDERS)

Net\_Mig\_E = IF TIME = 0 THEN 0 ELSE M\_NETCHANGE\_EL

T\_HATCH(t) = T\_HATCH(t - dt) + (Hatch - Grow - Death\_Ha) \* dt

INIT T\_HATCH = G\_HATCHLING

Hatch = IF TIME = 0 THEN 0 ELSE max(0.0, (E\_Survive \* (1 / Incu\_Time) \* T\_EGGS))

Grow = IF TIME = 0 THEN 0 ELSE max(0.0, (Ha\_Survive \* (1 / Hatchling\_Time) \* T\_HATCH))

Death\_Ha = IF TIME = 0 THEN 0 ELSE max(0.0, (1 - Ha\_Survive) \* T\_HATCH)

T\_JUV(t) = T\_JUV(t - dt) + (Grow - Net\_Mig\_J - Mature - Death\_J) \* dt

INIT T\_JUV = G\_JUVENILE

Grow = IF TIME = 0 THEN 0 ELSE max(0.0, (Ha\_Survive \* (1 / Hatchling\_Time) \* T\_HATCH))

Net\_Mig\_J = IF TIME = 0 THEN 0 ELSE M\_NETCHANGE\_JV

Mature = IF TIME = 0 THEN 0 ELSE max(0.0, (J\_Survive\*(1/Juv\_Time)\*T\_JUV))  
{adult recruitment per dt per cell}

Death\_J = IF TIME = 0 THEN 0 ELSE max(0.0, ((1-J\_Survive)/DT) \* T\_JUV)

Adult\_Die\_disease = 0.0175

Adult\_Die\_hib = 0.01

Adult\_Die\_pred = 0.001

Adult\_surv\_total = IF Hibernation = 1 THEN (1 - Adult\_Die\_hib - Adult\_Die\_disease)^40  
ELSE (1 - Adult\_Die\_disease - Adult\_Die\_food - Adult\_Die\_water - Adult\_Die\_pred)^40

A\_Survive = IF Adult\_surv\_total = 0 THEN 0  
ELSE EXP(LOGN(Adult\_surv\_total)\*(1/A\_Time)\*DT)

A\_Time = 480 {40 years}

cell\_area = 1 {km^2}

Density = TOTAL\_TORT/cell\_area {Number of tortoises per cell}

Egg\_lay = Clutch\_Size \* ((prop\_rep\_adult \* INT(T\_ADULT)) + (prop\_rep\_elder \* INT(T\_ELDERS)))

Eld\_Survive = IF Eld\_surv\_total = 0 THEN 0  
ELSE EXP(LOGN(Eld\_surv\_total) \* (1 / Eld\_Time))

Eld\_surv\_total = IF Hibernation = 1 THEN (1 - Adult\_Die\_hib - Adult\_Die\_disease)^10  
ELSE (1 - Adult\_Die\_disease - Adult\_Die\_food - Adult\_Die\_water - Adult\_Die\_pred)^10

Eld\_Time = 120 {number of months before elders die}

E\_Die\_infert = 0.50

E\_Survive = EXP(LOGN(E\_surv\_total) \* (1 / Incu\_Time))

E\_surv\_total = 1 - E\_Die\_infert - E\_Die\_pred

Hatchling\_Time = 60 {5 years}

Ha\_Survive = EXP(LOGN(H\_surv\_total) \* (1 / Hatchling\_Time))

Hibernation = IF C\_Air\_temp\_Cel >= 35 OR C\_Air\_temp\_Cel <= 15 THEN 1 ELSE 0

H\_Die\_hib\_aest = 0.05

H\_Die\_natl = 0.10

H\_surv\_total = IF Hibernation = 1 THEN (1 - H\_Die\_hib\_aest)^5 ELSE (1 - H\_Die\_natl - H\_Die\_pred)^5

Incu\_Time = 3

Juv\_Time = 210 {number of months needed for juveniles to mature into reproductive adults; 17.5 years}

J\_Die\_disease = 0.017

J\_Die\_hib\_aest = 0.01

J\_Survive = IF J\_surv\_total = 0 THEN 0  
ELSE EXP(LOGN(J\_surv\_total)\*(1/Juv\_Time)\*DT) {model juvenile survival}

J\_surv\_total = IF Hibernation = 1 THEN (1 - J\_Die\_hib\_aest - J\_Die\_disease) ^ 17.5  
ELSE (1 - J\_Die\_disease - J\_Die\_food - J\_Die\_pred - J\_Die\_water) ^ 17.5

pct\_adult = 100 \* (T\_ADULT/Total\_Female\_Tortoises)

pct\_elder = 100 \* (T\_ELDERS/Total\_Female\_Tortoises)

pct\_hatchling = 100 \* (T\_HATCH/Total\_Female\_Tortoises)

pct\_juv = 100 \* (T\_JUV/Total\_Female\_Tortoises)

prop\_rep\_adult = IF MONTH = 4 THEN 1.00 ELSE IF MONTH = 5 THEN 0.80 ELSE  
IF MONTH = 6 THEN 0.04 ELSE 0.00

prop\_rep\_elder = 0.30 \* prop\_rep\_adult

Sex\_Ratio = 0.50

Total\_Female\_Tortoises = T\_ELDERS + T\_JUV + T\_ADULT + T\_HATCH

TOTAL\_TORT = Total\_Female\_Tortoises\*2 {total tortoises per cell}

T\_Stat = food\_stat \* water\_stat

Adult\_Die\_food = GRAPH(V\_PCT\_GRN\_AVAIL)  
(0.00, 0.0657), (4.55, 0.0648), (9.09, 0.0631), (13.6, 0.0602), (18.2, 0.0543), (22.7,  
0.0464), (27.3, 0.0347), (31.8, 0.0218), (36.4, 0.0136), (40.9, 0.00867), (45.5,  
0.0075), (50.0, 0.0075)

Adult\_Die\_water = GRAPH(C\_Relative\_SM)  
(0.00, 0.13), (0.273, 0.125), (0.545, 0.12), (0.818, 0.108), (1.09, 0.088), (1.36,  
0.0633), (1.64, 0.0432), (1.91, 0.0288), (2.18, 0.0208), (2.45, 0.0162), (2.73, 0.015),  
(3.00, 0.015)

Clutch\_Size = GRAPH(T\_Stat)

(0.5, 0.00), (0.55, 0.00), (0.6, 0.21), (0.65, 0.63), (0.7, 1.19), (0.75, 1.82), (0.8, 3.22), (0.85, 5.74), (0.9, 9.80), (0.95, 12.5), (1.00, 14.0)

E\_Die\_pred = GRAPH(V\_TOTAL\_COVER)  
 (0.00, 0.23), (10.0, 0.225), (20.0, 0.216), (30.0, 0.202), (40.0, 0.185), (50.0, 0.152), (60.0, 0.101), (70.0, 0.0437), (80.0, 0.0138), (90.0, 0.0023), (100, 0.00)

food\_stat = GRAPH(V\_PCT\_GRN\_AVAIL)  
 (0.00, 0.5), (5.00, 0.69), (10.0, 0.797), (15.0, 0.868), (20.0, 0.912), (25.0, 0.948), (30.0, 0.973), (35.0, 0.99), (40.0, 0.998), (45.0, 1.00), (50.0, 1.00)

H\_Die\_pred = GRAPH(V\_TOTAL\_COVER)  
 (0.00, 0.319), (10.0, 0.311), (20.0, 0.297), (30.0, 0.271), (40.0, 0.234), (50.0, 0.161), (60.0, 0.12), (70.0, 0.0878), (80.0, 0.0703), (90.0, 0.0541), (100, 0.05)

J\_Die\_food = GRAPH(V\_PCT\_GRN\_AVAIL)  
 (0.00, 0.044), (5.00, 0.0429), (10.0, 0.0414), (15.0, 0.0387), (20.0, 0.0326), (25.0, 0.0238), (30.0, 0.0179), (35.0, 0.0146), (40.0, 0.013), (45.0, 0.012), (50.0, 0.012)

J\_Die\_pred = GRAPH(V\_TOTAL\_COVER)  
 (0.00, 0.22), (10.0, 0.218), (20.0, 0.206), (30.0, 0.182), (40.0, 0.145), (50.0, 0.108), (60.0, 0.0824), (70.0, 0.0712), (80.0, 0.064), (90.0, 0.0608), (100, 0.06)

J\_Die\_water = GRAPH(C\_Relative\_SM)  
 (0.00, 0.132), (0.3, 0.132), (0.6, 0.129), (0.9, 0.121), (1.20, 0.107), (1.50, 0.0851), (1.80, 0.063), (2.10, 0.0506), (2.40, 0.0441), (2.70, 0.0409), (3.00, 0.04)

water\_stat = GRAPH(C\_Relative\_SM)  
 (0.00, 0.5), (0.3, 0.69), (0.6, 0.797), (0.9, 0.868), (1.20, 0.912), (1.50, 0.948), (1.80, 0.973), (2.10, 0.993), (2.40, 0.998), (2.70, 1.00), (3.00, 1.00)

### Vegetation Sub-Model

max\_green(t) = max\_green(t - dt) + (in\_max - out\_max) \* dt

INIT max\_green = 0

in\_max = max(0.0, (if MONTH = 4 then V\_PCT\_GRN else 0.0))

out\_max = max(0.0, (if MONTH = 10 then max\_green else 0.0))

percent\_shrub(t) = percent\_shrub(t - dt) + (shrub\_recover) \* dt

INIT percent\_shrub = G\_PCT\_SHRUB

shrub\_recover = max(0.0, (IF growing\_season = 1 and pct\_climax\_shrub - percent\_shrub >= rate\_of\_recover THEN rate\_of\_recover ELSE IF growing\_season = 1 and pct\_climax\_shrub - percent\_shrub > 0 THEN pct\_climax\_shrub - percent\_shrub ELSE 0))

Soil\_Compaction(t) = Soil\_Compaction(t - dt) + (- Recovery\_rate) \* dt

INIT Soil\_Compaction = G\_COMPACTION

Recovery\_rate = GRAPH(Soil\_Compaction {UNITS: kg/(cm<sup>2</sup>\*month)})

(4.00, 0.00), (4.10, 0.00), (4.20, 0.00), (4.30, 0.00), (4.40, 0.00), (4.50, 0.001), (4.60, 0.0009), (4.70, 0.0019), (4.80, 0.003), (4.90, 0.0045), (5.00, 0.0059), (5.10, 0.0079), (5.20, 0.0102), (5.30, 0.0116), (5.40, 0.0121), (5.50, 0.0121), (5.60, 0.0121), (5.70, 0.0121), (5.80, 0.0121), (5.90, 0.0121), (6.00, 0.0121)

$V\_PCT\_BRN(t) = V\_PCT\_BRN(t - dt) + (outgreen - outbrown) * dt$

INIT  $V\_PCT\_BRN = G\_ADJBROWN$

outgreen = if TIME =0 then 0 else max(0.0, (IF  $K\_Compacted = 0$  THEN  $V\_PCT\_GRN$  ELSE IF growing\_season = 1 THEN (propdie\_competn \* r \*  $V\_PCT\_GRN^2 / K\_Compacted$ ) ELSE MAX(grncoverloss\_natl, 0)))

outbrown = if TIME =0 then 0 else MAX(0.0, brncoverloss\_decomp)

$V\_PCT\_GRN(t) = V\_PCT\_GRN(t - dt) + (ingreen - outgreen) * dt$

INIT  $V\_PCT\_GRN = G\_ADJGREEN$

ingreen = if TIME=0 then 0 else max(0.0, (IF growing\_season = 0 or  $K\_Compacted = 0$  THEN 0 ELSE IF  $V\_PCT\_GRN > 0$  THEN  $V\_PCT\_GRN * r - propnogrow\_competn * r * V\_PCT\_GRN^2 / K\_Compacted$  ELSE  $K\_Compacted * 0.01$ ))

outgreen = if TIME =0 then 0 else max(0.0, (IF  $K\_Compacted = 0$  THEN  $V\_PCT\_GRN$  ELSE IF growing\_season = 1 THEN (propdie\_competn \* r \*  $V\_PCT\_GRN^2 / K\_Compacted$ ) ELSE MAX(grncoverloss\_natl, 0)))

$brncoverloss\_decomp = V\_PCT\_BRN * propdecomp\_natl$

$climax\_shrub\_cover = (4.690945 + G\_SLOPE*0.355581 + G\_ASPECT*0.010774 + G\_ELEV*-0.001556 + G\_ELEV*G\_ELEV*0.000000861 + G\_SLOPE*G\_ASPECT*0.000462 + G\_SLOPE*G\_ELEV*-0.000064029)$

$Distance\_from\_K = G\_VEG\_K - V\_PCT\_GRN$

$grncoverloss\_natl = max\_green * 0.75 / 6$

growing\_season = if MONTH <= 4 or MONTH =11 then 1 else 0

$K\_Adjusted = propchange\_K * G\_VEG\_K$

$K\_Compacted = K\_Adjusted - (K\_Adjusted * propchange\_Kadj)$

max\_decomp = .5

$pct\_climax\_shrub = 100 * (climax\_shrub\_cover/G\_VEG\_K)$

$propchange\_Kadj = 0.15 * Relative\_Compaction$

$propdecomp\_natl = propdecomp\_SM * propdecomp\_ST * max\_decomp$

propdie\_competn = 0.1

propnogrow\_competn = (1 - propdie\_competn)

r = 0.85

rate\_of\_recover = 0.00069

Relative\_Compaction = (Soil\_Compaction - 4)/13

shrub\_cover = (percent\_shrub/100) \* V\_PCT\_GRN

V\_PCT\_GRN\_AVAIL = V\_PCT\_GRN - shrub\_cover\*0.75

V\_TOTAL\_COVER = V\_PCT\_BRN + V\_PCT\_GRN

propchange\_K = GRAPH(C\_Relative\_SM)

(0.00, 0.909), (0.2, 0.935), (0.4, 0.956), (0.6, 0.973), (0.8, 0.987), (1, 1.00), (1.20, 1.01), (1.40, 1.02), (1.60, 1.02), (1.80, 1.02), (2.00, 1.03)

propdecomp\_SM = GRAPH(C\_Soil\_Moisture)

(0.00, 0.27), (3.90, 0.485), (7.80, 0.64), (11.7, 0.75), (15.6, 0.835), (19.5, 0.9), (23.4, 0.945), (27.3, 0.98), (31.2, 1.00), (35.1, 1.00), (39.0, 1.00)

propdecomp\_ST = GRAPH(C\_Surf\_Temp\_C)

(11.0, 0.2), (14.2, 0.46), (17.4, 0.65), (20.6, 0.815), (23.8, 0.915), (27.0, 0.98), (30.2, 1.00), (33.4, 1.00), (36.6, 1.00), (39.8, 1.00), (43.0, 1.00)

## Inputs

cellsize = 1

C\_Deterministic = 1

G\_ADJBROWN = GIS data layer

G\_ADJGREEN = GIS data layer

G\_ADULT = GIS data layer

G\_APR\_SM = GIS data layer

G\_ASPECT = GIS data layer

G\_AUG\_SM = GIS data layer

G\_AWC\_per\_inch = GIS data layer

G\_COMPACTION = GIS data layer

G\_DEC\_SM = GIS data layer

G\_ELDER = GIS data layer

G\_ELEV = GIS data layer

G\_FEB\_SM = GIS data layer

G\_HATCHLING = GIS data layer

G\_INIT\_SM = GIS data layer

G\_JAN\_SM = GIS data layer

G\_JUL\_SM = GIS data layer

G\_JUN\_SM = GIS data layer

G\_JUVENILE = GIS data layer

G\_MAR\_SM = GIS data layer

G\_MAY\_SM = GIS data layer

G\_NOV\_SM = GIS data layer  
G\_OCT\_SM = GIS data layer  
G\_PCT\_SHRUB = GIS data layer  
G\_SEP\_SM = GIS data layer  
G\_SLOPE = GIS data layer  
G\_VEG\_K = GIS data layer  
Hab = 1  
MONTH = MOD(TIME,12)  
on\_map = 1

## USACERL DISTRIBUTION

## Chief of Engineers

ATTN: CEHEC-IM-LH (2)  
ATTN: CEHEC-IM-LP (2)  
ATTN: CECC-R  
ATTN: CERD-L

## Army Headquarters

ATTN: DAIM-ED-N (5)  
ATTN: DAMO-TRO  
ATTN: ANOP  
ATTN: AMSTE-EQ  
ATTN: SFIM-AEC-ECN  
ATTN: ATIC-CTS  
ATTN: FKEN-EN  
ATTN: AEAGC-TD-MO  
ATTN: EAGC-TD-RMD  
ATTN: APOP-TR  
ATTN: APEN-EV

## US Army Europe

ATTN: AEAEN-ENVR 09114  
100th Support Group  
ATTN: AETT-EN-DPW 09114  
CMTC Hohenfels 09173  
ATTN: AETTH-DPW

## FORSCOM

Fts Gillem & McPherson 30330  
ATTN: AFOP-TE  
ATTN: AFOP-TSR  
ATTN: AFPI-ENE

## Installations:

Fort Indiantown Gap 17003  
ATTN: AFKA-ZQ-DE-E  
Fort AP Hill 22427  
ATTN: ANAP-PWE  
ATTN: AFZM-FHE  
Fort McPherson 30330  
ATTN: AFZK-EH-E  
Fort Riley 66442  
ATTN: AFZN-DE-V-N  
Fort Polk 71459  
ATTN: AFZH-DE-EN  
Fort Sam Houston 78234  
ATTN: AFZG-DE-EM  
Fort Lewis 98433  
ATTN: AFZH-DE-Q  
Fort Carson 80913  
ATTN: AFZC-ECM-NR  
Fort Bragg 28307  
ATTN: AFZA-PW-DW  
Fort Campbell 42223  
ATTN: AFZB-DPW-E  
Fort McCoy 54656  
ATTN: AFZR-DE-E  
Fort Pickett 23824  
ATTN: AFZA-FP-E  
Fort Stewart 31314  
ATTN: AFZP-DEV  
Fort Buchanan 00934

ATTN: AFZK-B-EHE  
Fort Devens 01433  
ATTN: AFZD-DEM  
Fort Drum 13602  
ATTN: AFZS-EH-E  
Fort Irwin 92310  
ATTN: AFZJ-EHE-EN  
Fort Hood 76544  
ATTN: AFZF-DE-ENV  
Fort Hunter Liggett 93928  
ATTN: AFZW-HE-DE  
Yakima Tng Center 98901-5000  
ATTN: AFZH-Y-ENR  
Fort Dix 08640  
ATTN: ATZD-EH

## TRADOC

Fort Monroe 23651  
ATTN: ATBO-FE

## Installations:

Fort Lee 23801  
ATTN: ATZM-PTS-T  
Fort Jackson 29207  
ATTN: ATZJ-PWN  
Fort Gordon 30905  
ATTN: ATZH-DIE  
Fort Benning 31905  
ATTN: ATZB-PWN  
Fort McClellan 36205  
ATTN: ATZN-EM  
Fort Rucker 36362  
ATTN: ATZQ-DPW-EN  
Fort Leonard Wood 64573  
ATTN: ATZT-DPW-EE  
Fort Leavenworth 66027  
ATTN: ATZL-GCE  
Fort Bliss 79916  
ATTN: ATZC-DOE  
Carlisle Barracks 17013  
ATTN: ATZE-DPW-E  
Fort Eustis 23604  
ATTN: ATZF-PWE  
Fort Chaffee 72905  
ATTN: ATZR-ZF  
Fort Sill 73503  
ATTN: ATZR-B  
Fort Huachuca 85613  
ATTN: ATZS-EHB  
Fort Knox 40121  
ATTN: ATZK-PWE

## USAMC Instal &amp; Srvc Activity

ATTN: AMXEN-M 61299  
Rock Island Arsenal  
ATTN: AMSMC-EHR  
ATTN: SMCRI-PWB  
White Sands Missile Range  
ATTN: STEWS-ES-E  
US Army Dugway Proving Ground  
ATTN: STEDP-EPO-CP

US Army Yuma Proving Ground  
ATTN: STEYP-ES-E

Aberdeen Proving Ground  
ATTN: STEAP-SH-ER

## National Guard Bureau 20310

ATTN: NGB-ARE  
ATTN: NGB-ARI  
ATTN: NGB-ARO-TS

## Army National Guard

Ft. Richardson, AK 99505-5800  
Phoenix, AZ 85008-3495  
Sacramento, CA 95826-9101  
Boise, ID 83705-8095  
Jackson, MS 39209  
Camp Shelby, MS 39407-5500  
Oklahoma City, OK 73111-4389  
Draper, UT 84020-1776  
Braggs, OK 74423  
Reading, MA 01867-1999  
Camp Edwards, MA 02542-5003  
Richmond, VA 23219  
Columbia, SC 29201  
Eastover, SC 29244  
St. Augustine, FL 32085  
Starke, FL 32091  
Indianapolis, IN 46241  
Lansing, MI 48913  
Little Falls, MN 56345  
Jefferson, MO 65101  
Camp Roberts, CA 93451  
Camp Robinson, AR 72118-2200

## US Military Academy 10996

ATTN: MAEN-EV  
ATTN: DOPS

## US Army Research Laboratory

ATTN: AMSRL-OP-SDFE

## US Govt Printing Office 20401

ATTN: Rec Sec/Deposit Sec

## Defense Technical Info Ctr 22304

ATTN: DTIC-FAB