

NAVAL POSTGRADUATE SCHOOL
Monterey, California



THESIS

**PEROXONE GROUNDWATER TREATMENT OF
EXPLOSIVE CONTAMINANTS DEMONSTRATION
AND EVALUATION**

by

Michael Victor McCrea

March 1997

Thesis Advisor:

Lyn Whitaker

Approved for public release; distribution is unlimited.

19970905 135

REPORT DOCUMENTATION PAGE

Form Approved
OMB No. 0704-0188

Public reporting burden for this collection of information is estimated to average 1 hour per response, including the time for reviewing instructions, searching existing data sources, gathering and maintaining the data needed, and completing and reviewing the collection of information. Send comments regarding this burden estimate or any other aspect of this collection of information, including suggestions for reducing this burden to Washington Headquarters Services, Directorate for Information Operations and Reports, 1215 Jefferson Davis Highway, Suite 1204, Arlington, VA 22202-4302, and to the Office of Management and Budget, Paperwork Reduction Project (0704-0188), Washington, DC 20503.

1. AGENCY USE ONLY (Leave Blank)	2. REPORT DATE March 1997	3. REPORT TYPE AND DATES COVERED Master's Thesis	
4. TITLE AND SUBTITLE PEROXONE GROUNDWATER TREATMENT OF EXPLOSIVE CONTAMINANTS DEMONSTRATION AND EVALUATION		5. FUNDING NUMBERS	
6. AUTHOR(S) McCrea, Michael V.			
7. PERFORMING ORGANIZATION NAME(S) AND ADDRESS(ES) Naval Postgraduate School Monterey, CA 93943-5000		8. PERFORMING ORGANIZATION REPORT NUMBER	
9. SPONSORING / MONITORING AGENCY NAME(S) AND ADDRESS(ES)		10. SPONSORING / MONITORING AGENCY REPORT NUMBER	
11. SUPPLEMENTARY NOTES The views expressed in this thesis are those of the author and do not reflect the official policy or position of the Department of Defense or the U.S. Government.			
12a. DISTRIBUTION / AVAILABILITY STATEMENT Approved for public release, distribution is unlimited		12b. DISTRIBUTION CODE	
13. ABSTRACT (Maximum 200 words) The purpose of this thesis is to evaluate the performance and cost effectiveness of a <i>Peroxone</i> Groundwater Treatment Plant (PGTP) designed and operated by Montgomery Watson, in support of the Defense Evaluation Support Agency's independent analysis for the United States Army Environmental Center (USAEC). Many Department of Defense installations have sites that contain groundwater contaminated with explosive materials. Primary methods for the removal of explosive materials involve the use of Granular Activated Carbon (GAC). This process, however, requires additional waste disposal and treatment of explosive laden GAC, thereby incurring additional costs. An alternate method for the treatment of contaminated groundwater involves the use of hydrogen peroxide (H ₂ O ₂) in conjunction with ozone (O ₃). This method is referred to as the <i>Peroxone</i> oxidation process. A demonstration of the PGTP was conducted from 19 August to 8 November, 1996, at Cornhusker Army Ammunition Plant (CAAP), Grand Island, Nebraska using a small scale version with a maximum flow rate of 25 gallons per minute. The explosive contaminants analyzed during the demonstration include 2,4,6-Trinitrotoluene (TNT), 1,3,5-Trinitrobenzene (TNB), 1,3,5-Triazine (RDX), and Total Nitrobenzenes. <i>Peroxone</i> cost effectiveness was evaluated using a 30 year life cycle cost comparison to GAC and Ultraviolet/Ozone processes.			
14. SUBJECT TERMS Peroxone, Granular Activated Carbon, TNB, TNT, RDX		15. NUMBER OF PAGES 74	
		16. PRICE CODE	
17. SECURITY CLASSIFICATION OF REPORT Unclassified	18. SECURITY CLASSIFICATION OF THIS PAGE Unclassified	19. SECURITY CLASSIFICATION OF ABSTRACT Unclassified	20. LIMITATION OF ABSTRACT UL

Approved for public release; distribution is unlimited.

**PEROXONE GROUNDWATER TREATMENT OF EXPLOSIVE
CONTAMINANTS DEMONSTRATION AND EVALUATION**

Michael V. McCrea
Captain, United States Army
B.S., United States Military Academy, 1987

Submitted in partial fulfillment
of the requirements for the degree of

MASTER OF SCIENCE IN OPERATIONS RESEARCH

from the

**NAVAL POSTGRADUATE SCHOOL
March 1997**

Author:

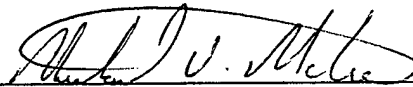

Michael V. McCrea

Approved by:

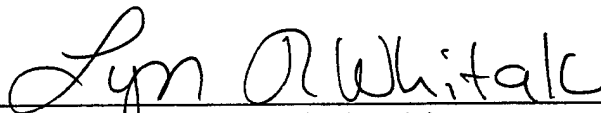

Lynn Whitaker, Thesis Advisor

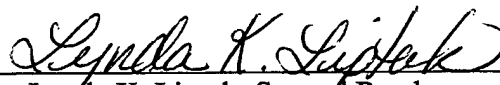

Lynda K. Liptak, Second Reader

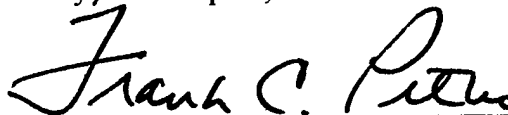

Frank C. Petho, Chairman
Department of Operations Research

ABSTRACT

The purpose of this thesis is to evaluate the performance and cost effectiveness of a *Peroxone* Groundwater Treatment Plant (PGTP) designed and operated by Montgomery Watson, in support of the Defense Evaluation Support Agency's independent analysis for the United States Army Environmental Center (USAEC). Many Department of Defense installations have sites that contain groundwater contaminated with explosive materials. Primary methods for the removal of explosive materials involve the use of Granular Activated Carbon (GAC). This process, however, requires additional waste disposal and treatment of explosive laden GAC, thereby incurring additional costs. An alternate method for the treatment of contaminated groundwater involves the use of hydrogen peroxide (H_2O_2) in conjunction with ozone (O_3). This method is referred to as the *Peroxone* oxidation process. A demonstration of the PGTP was conducted from 19 August to 8 November, 1996, at Cornhusker Army Ammunition Plant (CAAP), Grand Island, Nebraska using a small scale version with a maximum flow rate of 25 gallons per minute. The explosive contaminants analyzed during the demonstration include 2,4,6-Trinitrotoluene (TNT), 1,3,5-Trinitrobenzene (TNB), 1,3,5-Triazine (RDX), and Total Nitrobenzenes. *Peroxone* cost effectiveness was evaluated using a 30 year life cycle cost comparison to GAC and Ultraviolet/Ozone processes.

TABLE OF CONTENTS

I. INTRODUCTION	1
A. BACKGROUND	1
B. PURPOSE AND OVERVIEW.....	2
C. <i>PEROXONE</i> DEMONSTRATION BACKGROUND	2
1. <i>Peroxone</i> Technology	3
2. Demonstration Agencies	3
3. Identification of Comparative Systems	4
D. <i>PEROXONE</i> DEMONSTRATION PLANT DESCRIPTION.....	4
E. SUMMARY OF CONTENTS.....	6
II. <i>PEROXONE</i> DEMONSTRATION	7
A. DEMONSTRATION DESCRIPTION.....	7
1. System Startup and Calibration	7
2. Process Optimization	7
3. Demonstration.	8
B. DATA COLLECTION REQUIREMENTS.....	9
1. Water Samples.....	10
2. Additional Water Standards	11
III. DEMONSTRATION ANALYSIS	13
A. WATER SAMPLE ANALYSIS METHOD	13
1. Effluent Analysis.....	13
2. Influent vs. Effluent Analysis.....	13
3. Contactor Analysis.....	13
B. 13 GPM FLOW RATE ANALYSIS.....	14
1. Effluent Analysis.....	15
2. Influent vs. Effluent Analysis.....	15
3. Contactor Analysis.....	16

C. MAXIMUM FLOW RATE ANALYSIS	18
1. Effluent Analysis	19
2. Influent vs. Effluent Analysis	20
3. Contactor Analysis	20
D. SUMMARY AND DISCUSSION OF DEMONSTRATION ANALYSIS	21
IV. COST ANALYSIS	25
A. GAC COST ESTIMATES	25
1. GAC/Thermal Regeneration Cost Estimate	26
2. GAC/Incineration Cost Estimate	26
B. UV/OX COST ESTIMATE	27
C. <i>PEROXONE</i> COST ESTIMATES	29
1. GAC MINUS Cost Estimate	29
2. GAC PLUS Cost Estimate	30
D. COST ESTIMATE COMPARISON	30
V. CONCLUSIONS AND RECOMMENDATIONS	33
A. CONCLUSIONS	33
B. RECOMMENDATIONS	33
APPENDIX A. RAW DATA	35
APPENDIX B. DEMONSTRATION RESULTS	41
APPENDIX C. ANALYSIS RESULTS	47
APPENDIX D. GAC AND UV/OX COST DATA	55
APPENDIX E. PEROXONE COST DATA	57
LIST OF REFERENCES	59
INITIAL DISTRIBUTION LIST	61

EXECUTIVE SUMMARY

Many Department of Defense installations have sites that contain groundwater contaminated with explosive materials. The explosive materials are a result of ammunition production plant operations and years of weapon live fire exercises at military installations and maneuver/training areas. Primary methods for the removal of explosive materials involve the use of Granular Activated Carbon (GAC). This process consists of running the groundwater through a series of GAC filters. The filters trap the explosive contaminants and pass treated water through the system. The GAC process however, requires additional waste disposal and treatment of the filters, thereby incurring additional costs. An alternate method for the treatment of contaminated groundwater involves the use of hydrogen peroxide (H_2O_2) in conjunction with ozone (O_3). This method is referred to as the *Peroxone* oxidation process.

The purpose of this thesis is to evaluate a *Peroxone* Groundwater Treatment Plant (PGTP). A demonstration of the PGTP was conducted at Cornhusker Army Ammunition Plant (CAAP), Grand Island, Nebraska using a small scale version with a maximum flow rate of 25 gallons per minute. The explosive contaminants analyzed during the demonstration include 2,4,6-Trinitrotoluene (TNT), 1,3,5-Trinitrobenzene (TNB), 1,3,5-triazine "Royal Demolition Explosives" (RDX) and Total Nitrobodyes. This thesis supports the Defense Evaluation Support Agency's (DESA) analysis in the independent evaluation of the *Peroxone* system for the United States Army Environmental Center (USAEC). The evaluation answers two operational issues identified by DESA:

- Does the system meet standards for removal of contaminated groundwater?
- Is the *Peroxone* system more cost-effective than existing systems for groundwater treatment of explosives?

The results of this analysis provide assistance for USAEC in determining the value of the *Peroxone* oxidation process for full scale implementation.

The United States Army Environmental Center (USAEC) sponsored the *Peroxone* demonstration. TRW Space and Technology Division, the prime contractor, subcontracted Montgomery Watson to design, build, and demonstrate the PGTP. The Cornhusker Army Ammunition Plant (CAAP) hosted the demonstration at Grand Island, Nebraska from 19 August to 8 November, 1996. The U.S. Army Corps of Engineers and Corps of Engineers Construction Engineering Research Laboratory (CERL) served as technical advisors.

The entire PGTP demonstration actually consisted of a startup period, a process optimization period, and the demonstration period. Based on results from the optimization period of the demonstration, the PGTP was operated at a flow rate of 13 gallons per minute (gpm), the optimal flow rate, for twenty-one days and at 25 gpm, the maximum design flow rate, for twenty days.

The intent of the optimization phase was to determine the optimal flow rate and dosages required to meet treatment goals; thus, at a flow rate of 13 gpm, the PGTP removed all explosive contaminant levels well below required goals. At the maximum flow rate, 1,3,5-Trinitrobenzene (TNB) was not removed to the treatment goal of 2.0 $\mu\text{g} / \text{L}$ of groundwater after contactor treatment. However, TNB met State standards and was removed to a concentration below the treatment goal after subsequent GAC treatment.

To evaluate the cost effectiveness of the *Peroxone* method, USAEC directed the comparison of *Peroxone* to two proven methods for removal of explosive groundwater contaminants. The two methods are Granular Activated Carbon (GAC) method and the Ultraviolet/Ozone (UV/OX) method. UV/OX is also a chemical oxidation process and was recently demonstrated successfully in 1993 by USAEC.

DESA's operational issue of *Peroxone* cost effectiveness is based on a 30 year life cycle cost comparison to GAC and UV/OX processes at a standardized yearly treatment rate for similar demonstration scale treatment plants. Cost estimates are calculated for both the 13 gpm and 25 gpm demonstrations. Based on the data obtained during this demonstration, the cost estimates indicate that *Peroxone* is the least expensive method for treatment of the explosive contaminants TNB, TNT, RDX, and Total Nitrobodyes.

I. INTRODUCTION

A. BACKGROUND

The reshaping of the military in response to the end of the Cold War has had an impact on several areas of defense, readiness, training, personnel, and maintenance to name a few. Another area involves the future of military installations. To assist in the vast number of decisions required when down-sizing the military, Congress established the Base Realignment and Closure Committee (BRAC). One function of BRAC is to determine the optimal location of the mandated force structure and associated support structures. This often involves the closure of a military installation, and the relocation of the military unit or Department of Defense (DoD) Contract.

Once an installation is scheduled for closure, the ultimate goal of the Department of Defense is to return the land to the local community. The Fort Ord Reuse Authority (FORA) is one example of an organization established to return a former military installation back to the civilian community. Conversion of prior military lands for public use involves significant preparation. Groundwater contamination, one area of concern, is receiving detailed attention from the Department of Defense, Department of Energy, and the United States Army Environmental Center (USAEC).

Many Department of Defense installations have sites that contain groundwater contaminated with explosive materials. The explosive materials are a result of ammunition production plant operations and years of weapon live fire exercises at military installations and maneuver/training areas. The primary method for the removal of explosive materials involve the use of Granular Activated Carbon (GAC). The Seattle District, Corps of Engineers is currently operating a GAC plant to remove explosive materials at Umatilla Army Depot, Oregon. This process consists of running the groundwater through a series of GAC filters. The filters are designed to trap the explosive contaminants and pass

treated water through the system. However, the GAC process requires additional waste disposal and treatment of the filters, which incur additional costs. An alternate method for the treatment of contaminated groundwater involves the use of hydrogen peroxide (H_2O_2) in conjunction with ozone (O_3). This method is referred to as the *Peroxone* oxidation process. *Peroxone* and other types of chemical oxidation have the advantage over other methods since oxidation converts explosive compounds to innocuous by-products rather than requiring additional treatment. [Ref. 1:p. 1-2]

B. PURPOSE AND OVERVIEW

The purpose of this thesis is to evaluate a *Peroxone* Groundwater Treatment Plant (PGTP). A demonstration of the PGTP was conducted at Cornhusker Army Ammunition Plant (CAAP), Grand Island, Nebraska using a small scale version with a maximum flow rate of 25 gallons per minute. The explosive contaminants analyzed during the demonstration include 2,4,6-Trinitrotoluene (TNT), 1,3,5-Trinitrobenzene (TNB), 1,3,5-triazine "Royal Demolition Explosives" (RDX) and Total Nitrobodyes. This thesis supports the Defense Evaluation Support Agency's (DESA) analysis in the independent evaluation of the *Peroxone* system for the United States Army Environmental Center (USAEC). The evaluation answers two operational issues identified by DESA:

- Does the system meet standards for removal of contaminated groundwater?
- Is the *Peroxone* system more cost-effective than existing systems for groundwater treatment of explosives?

The results of this analysis will provide assistance for USAEC in determining the value of the *Peroxone* oxidation process for full scale implementation.

C. PEROXONE DEMONSTRATION BACKGROUND

The *Peroxone* oxidation process for explosive contaminant removal traces its roots to the Corps of Engineers' Waterways Experiment Station (WES). WES developed the *Peroxone* treatment technology as the lead research laboratory for DoD [Ref. 2:p. 1].

WES, involved in environmental cleanup, conducts aggressive research and technology development to reduce the cost and time required to solve soil and groundwater issues. "WES cleanup technology supports the Installation Restoration, BRAC, and Formerly Used Defense Site Programs" [Ref. 3].

1. Peroxone Technology

The *Peroxone* oxidation process involves the introduction of hydrogen peroxide (H_2O_2) and ozone (O_3) into a series of containers through which the contaminated groundwater flows. Hydrogen peroxide in conjunction with ozone form powerful oxidizers referred to as hydroxyl radicals. The formation of the radicals classifies the *Peroxone* process as an Advanced Oxidation Process (AOP). These hydroxyl radicals react with and destroy most contaminants in groundwater. Laboratory and field tests by WES indicated that the process does destroy explosive contaminants in this manner and served as the bench mark for a pilot study by WES [Ref. 4].

The WES pilot study was conducted at the Cornhusker Army Ammunition Plant (CAAP) in August, 1995. It consisted of a four week trial on a field scale model with an approximate flow rate of one gallon per minute (gpm). Preliminary laboratory results from this study showed that TNT and RDX were oxidized by the *Peroxone* process. [Ref. 1] These test results are used in the design criteria for the *Peroxone* demonstration model.

2. Demonstration Agencies

The United States Army Environment Center (USAEC) is the sponsor for the *Peroxone* demonstration. TRW Space and Technology Division, the prime contractor, subcontracted Montgomery Watson to design, build, and demonstrate a 25 gallon per minute *Peroxone* treatment plant. Montgomery Watson has demonstrated experience in the *Peroxone* process. In 1989, Montgomery Watson used *Peroxone* to reduce trihalomethane (THM) in Southern California water in response to new standards from the

Environmental Protection Agency [Ref. 5]. The demonstration host is the Cornhusker Army Ammunition Plant (CAAP) at Grand Island, Nebraska. The U.S. Army Corps of Engineers and Corps of Engineers' Construction Engineering Research Laboratory (CERL) serve as technical advisors. DESA provides an independent evaluation of USAEC's *Peroxone* demonstration.

3. Identification of Comparative Systems

To evaluate the cost effectiveness of the *Peroxone* method, USAEC has directed the comparison of *Peroxone* to two proven methods for removal of explosive groundwater contaminants. The two methods are the Granular Activated Carbon (GAC) method, operating in Umatilla Army Depot, Oregon and the Ultraviolet/Ozone method, often referred to as UV/OX, operating in Milan, Tennessee. UV/OX is also a chemical oxidation process and was recently demonstrated successfully in 1993 by USAEC [Ref. 6].

D. PEROXONE DEMONSTRATION PLANT DESCRIPTION

The contaminant levels anticipated prior to the demonstration and the corresponding treatment goals are given in Table 1. USAEC set the treatment goals for

Contaminant	Anticipated Groundwater Concentration (mg/L)	Treatment Goals After <i>Peroxone</i> Treatment (mg/L)
TNT	0.5	0.002
RDX	0.2	0.002
TNB	0.1	0.002
Total Nitrocompounds	1.0	0.030

Table 1. Anticipated Contaminant Levels and Treatment Goals After Ref. 1.

the listed contaminants. These goals are more stringent than those identified in the National Pollutant Discharge Elimination System (NPDES) permit requirements for the State of Nebraska. For example, Nebraska's NPDES standard for TNT is 0.004 mg/L of groundwater. As a minimum requirement, the PGTP must meet the treatment goals at least 90% of the time.

The primary components of the *Peroxone* demonstration plant consist of an influent feed pump, six water towers (contactors), an ozone generator and feed system, and a hydrogen peroxide tank. Liquid oxygen is used as the source for the ozone generation. A GAC polishing filter system is included at the end of the plant to ensure treated well water is safely deposited into a local ditch regardless of the effectiveness of the *Peroxone* method. An effluent tank collects treated water after the sixth contactor. In the effluent tank, residual ozone is diffused and pumped to the GAC polishing filters using an effluent pump. A schematic of the *Peroxone* Groundwater Treatment Plant (PGTP) layout is shown in Figure 1. [Ref. 1]

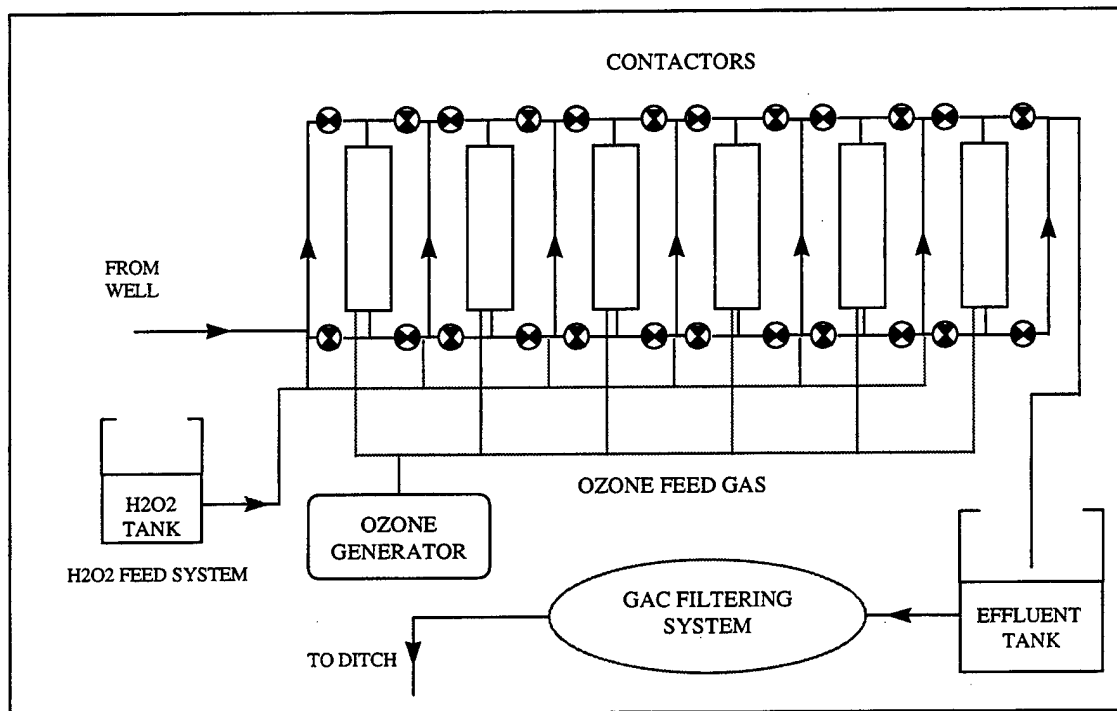

Figure 1. *Peroxone* Groundwater Treatment Plant (PGTP) Design After Ref. 7.

The chemical oxidation of explosive contaminants occurs in a series of six contactors. Each contactor is 10 feet high above the bubble diffuser base and 3 feet in diameter. With a flow rate of 25 gallons per minute (gpm), the total time a specific water (unit) spends in a single contactor is 20 minutes. This is referred to as the Hydraulic

Retention Time (HRT). Total HRT through the six contactors is 120 minutes at 25 gpm. The HRT increases as the flow rate decreases. [Ref. 1]

As water enters each contactor, it is treated with a predetermined mix of ozone and hydrogen peroxide. The initial H_2O_2 /Ozone ratio is set at a contracted design 0.30 mg/mg. This ratio, proven in past research by WES and Montgomery Watson, provides the most effective level of hydroxyl radicals required for oxidation [Ref. 7]. H_2O_2 is injected into the groundwater piping prior to the water entering each contactor. Two bubble dome diffusers in each contactor are used to introduce ozone evenly within the contactor. Water taps positioned prior to the first contactor and after all contactors allow for collection of water samples.

E. SUMMARY OF CONTENTS

This thesis consists of five chapters and five supporting appendices with the intent of giving the reader a thorough understanding of the *Peroxone* groundwater treatment process, the requirements and designs for the demonstration scale model, and supporting analysis for DESA's independent evaluation. Chapter II includes a description of the *Peroxone* demonstration and initial results. It describes the methods for water sample collection and pertinent evaluation criteria. Chapter III provides the analysis of the *Peroxone* system demonstration. The data are summarized and used to answer DESA's first critical operational objective for evaluating system performance. In Chapter IV, the cost effectiveness of the *Peroxone* method is then determined by comparing an estimated thirty year lifecycle cost for the *Peroxone* method with the 30 year lifecycle costs of the GAC and UV/OX methods. This cost comparison answers DESA's second critical operational issue. Chapter V contains the conclusions and recommendations.

II. PEROXONE DEMONSTRATION

A. DEMONSTRATION DESCRIPTION

DESA and Montgomery Watson conducted the *Peroxone* demonstration at CAAP, Grand Island, Nebraska from 19 August to 8 November 1996. Explosives contaminated groundwater exists at CAAP due to the production, assembly, and packaging of explosives for World War II, the Korean War, and the Vietnam War [Ref.1]. Montgomery Watson connected the PGTP to two groundwater sources (Wells 1 and 2), each having significant levels of the specified explosive contaminants. A third groundwater source was originally planned but later canceled due to the excessive distance from the source to the PGTP. The entire PGTP demonstration consisted of three periods. Montgomery Watson used the period from 19 August to 1 September for system startup and calibration and the period from 2 to 10 September to conduct process optimization. DESA conducted water sample data collection for the independent analysis from 13 September to 8 November.

1. System Startup and Calibration

During the calibration period, Montgomery Watson assembled and performed initial debugging of the PGTP at CAAP. A flow rate of 5 gpm was initially used to identify any existing water and chemical leaks. In addition, equipment including feed gas meters and safety alarms were calibrated. The optimization process period was not allowed to commence until proper calibrations were conducted and all necessary repairs were completed.

2. Process Optimization

Montgomery Watson used the process optimization period to determine the optimal hydrogen peroxide and ozone dosages and hydraulic retention time (HRT) required to reduce the explosive contaminants to treatment goals [Ref. 7]. Ozone dosage

per contactor is controlled by settings in the ozone generator. The hydrogen peroxide dosage is controlled by varying the pumping rate into each contactor through the "in-line injectors" [Ref. 1]. For fixed amounts of H₂O₂ and O₃ dosages, as the flow rate increases, the applied dosages per gallon of groundwater decreases. Optimization of the PGTP refers to selecting the highest flow rate that meets the treatment goals, thus incurring the lowest possible chemical costs per gallon. At the maximum flow rate for the PGTP of 25 gpm, the ozone and hydrogen peroxide dosages are at the lowest levels resulting in overall lower treatment cost.

During the process optimization period, all contaminants, except the explosive contaminant 1,3,5-Trinitrobenzene (TNB), met the treatment goal ($< 2.0 \mu\text{g} / \text{L}$) at the maximum flow rate of 25 gpm for wells one and two. Additionally, TNB failed to meet treatment goal at decreased flow rates of 20 or 18 gpm for either well. Optimal flow rate and respective H₂O₂ and O₃ dosages were not established during the scheduled optimization period. Montgomery Watson conducted two additional days of optimization at a lower flow rate of 13 gpm varying H₂O₂ and O₃ dosages, while still attempting to maintain a .30 mg/mg ratio of H₂O₂ to O₃. TNB met the required treatment goal at this lower flow rate of 13 gpm, a transferred O₃ dosage of 80 mg/L, and an H₂O₂ dosage of 24 mg/L.

3. Demonstration

The demonstration phase was designed to run the PGTP for an extended period of time under constant flow rate and the ozone dosage established during the process optimization period. This phase was the focus of DESA's independent analysis of the PGTP. The water samples collected during this period are used to answer DESA's first operational issue regarding the effectiveness of the PGTP in meeting the treatment goals. The data collection requirements are specified in Section B. Because the optimal flow rate was not established during the optimization phase, the demonstration phase was modified to consist of two distinct phases.

a. 13 GPM Flow Rate Demonstration

The first phase consisted of running the PGTP under constant conditions established during the process optimization period using a rate of 13 gpm and the corresponding H₂O₂ and O₃ dosages. Water samples were collected according to the sample requirements. This phase was conducted from 13 September 1996 until 11 October, 1996.

b. Maximum Flow Rate Demonstration

A flow rate of 13 gpm corresponds to operating the PGTP at approximately 50% of its contracted design capacity. With flow rate as an important criteria in PGTP design, USAEC and Montgomery Watson canceled the testing of the second well at 13 gpm. Instead they conducted a second task, with the first well, by continuously operating the PGTP at a maximum flow rate of 25 gpm. The PGTP operating at the maximum flow rate met state standards set by NPDES; but, it requires additional GAC treatment of the groundwater to meet required treatment goals. This maximum flow rate task was conducted from 12 October, 1996 until demonstration completion on 8 November, 1996.

B. DATA COLLECTION REQUIREMENTS

The data collection requirements for the demonstration focused on two general categories. The first requirement consists of collecting a series of water samples over the entire demonstration period for explosive contaminant analysis. This category of data is used to answer DESA's first operational objective: Does the system meet the standards for removal of explosive contaminated groundwater? The second data collection requirement focuses on the cost factors used to generate a lifecycle cost for the PGTP. This category of data is used for DESA's second operational objective: Is the *Peroxone* system more cost effective than existing systems for groundwater treatment of explosives? The remainder of the chapter describes the collection requirements and analysis for the first data requirement.

1. Water Samples

A significant number of water samples were taken at various locations on the PGTP to assist in the analysis of the plant's effectiveness. The samples were collected by DESA and sent to a laboratory for analysis of contaminant levels. Samples used in the analysis were quenched with sodium thiosulfate ($\text{Na}_2\text{S}_2\text{O}_3$) to ensure that further oxidation did not occur prior to laboratory analysis. On a daily basis, samples were collected from the location prior to the first contactor known as the influent (INF). Samples were also collected from a designated sampling point after each contactor. Figure 2 shows the structure of the contactors and the sampling points. The sampling point after the first contactor is labeled C1/0 and is similar in format for the other five contactors. A final sample was collected daily after the first GAC filter to ensure safe water emission from the PGTP. Turn around time for results from the laboratory were 24 hours by fax and 48 hours for final, verified results by fax. The number of samples collected per day during the demonstration are listed in Table 2.

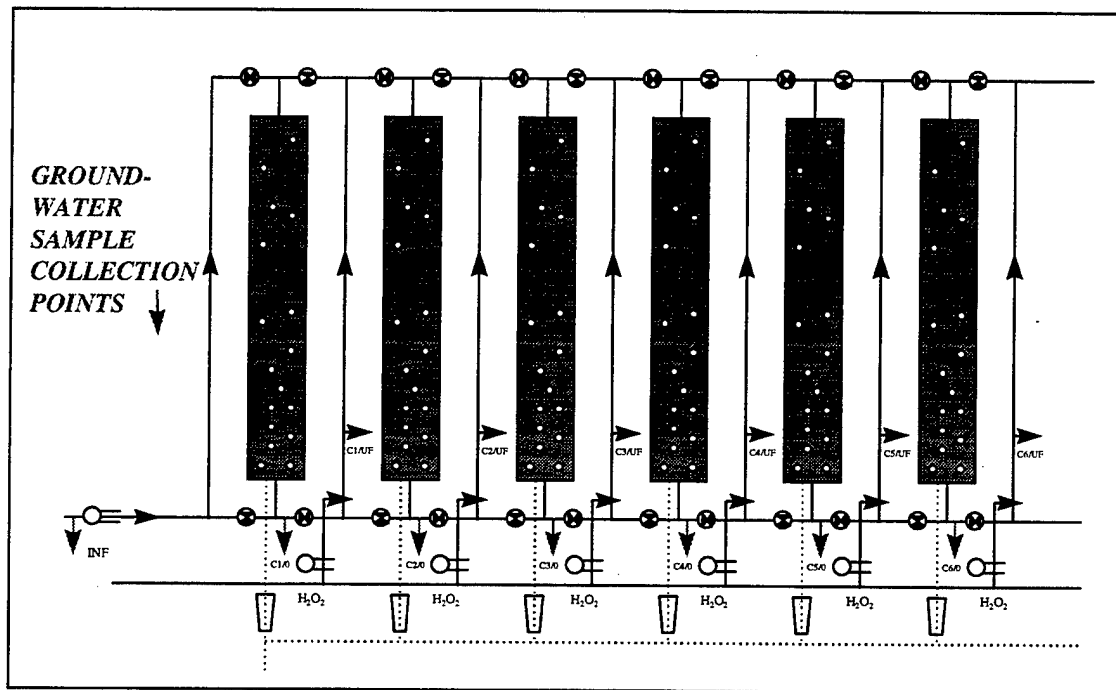

Figure 2. Contactor Collection Points From Ref. 8.

Sampling Location	# Samples per Day
Influent (INF)	4
Contactor 1 (C1/0)	1
Contactor 2 (C2/0)	1
Contactor 3 (C3/0)	1
Contactor 4 (C4/0)	1
Contactor 5 (C5/0)	1
Effluent (C6/0)	4

Table 2. Water Sample Collection Requirements.

2. Additional Water Standards

Water samples collected after the sixth contactor (C6/0) and the first GAC filter are compared to the given test standards provided by the Army Environmental Center for TNT, TNB, RDX, and Total Nitrobenzenes. The samples are also compared to the State standards required by NPDES listed in Table 3.

Contaminant	Daily Maximum Limit
TNB	4 $\mu\text{g} / \text{L}$
TNT	20 $\mu\text{g} / \text{L}$
RDX	100 $\mu\text{g} / \text{L}$
HMX	40 $\mu\text{g} / \text{L}$
1,3-dinitrobenzene	5 $\mu\text{g} / \text{L}$
4-amino-2,6-dinitrotoluene	40 $\mu\text{g} / \text{L}$
2,6-dinitrotoluene	40 $\mu\text{g} / \text{L}$
2-amino-4,6-dinitrotoluene	40 $\mu\text{g} / \text{L}$
2,4-dinitrotoluene	100 $\mu\text{g} / \text{L}$
2-nitrotoluene	40 $\mu\text{g} / \text{L}$
3-nitrotoluene	40 $\mu\text{g} / \text{L}$
methyl-2,4,6 -trinitrophenylnitramine	100 $\mu\text{g} / \text{L}$
4-nitrotoluene	100 $\mu\text{g} / \text{L}$
nitrobenzene	30 $\mu\text{g} / \text{L}$
nitrate as nitrogen	100.0 mg/L

Table 3. NPDES Water Standards After Ref. 9.

III. DEMONSTRATION ANALYSIS

A. WATER SAMPLE ANALYSIS METHOD

To provide a detailed analysis of the PGTP results, data is compared from various sampling locations. Specifically, the analysis focuses on the three types of comparisons identified below. The water samples were collected daily for each task in the modified demonstration period. Since specific water samples cannot be traced throughout the system, independence is assumed between samples taken at different collection points.

1. Effluent Analysis

Data collected from the effluent (C6/O) end is compared to the given standards provided by the Army Environmental Center for the primary explosive contaminants TNT, TNB, RDX, and Total Nitrobenzenes. The samples are also compared to the standards required by NPDES for the secondary contaminants.

2. Influent vs. Effluent Analysis

This analysis focuses on whether or not the explosive contaminated groundwater is treated sufficiently by the PGTP. The data collected from the effluent end of the PGTP on each contaminant is compared to the samples collected prior to entering the PGTP.

3. Contactor Analysis

The focus of the contactor analysis is contactor effectiveness in treatment of the contaminants. Results from this analysis will indicate at which contactor the primary explosive contaminant level fell below the treatment goals. Regression analysis of the contaminant concentration as a function of collection point will indicate whether or not a relationship exists between the effluent levels (C6/O) and the previous collection points. The intercept of the regression is the contaminant level at influent. Residual analysis is used to verify the modeling assumptions of the regression. This regression analysis can

assist in predicting final contaminant levels given an initial level at the influent and the required number of contactors to meet treatment goals.

B. 13 GPM FLOW RATE ANALYSIS

During this task of the modified demonstration, the PGTP was operated at a constant flow rate of 13 gpm. Tables of the contactor raw data are given in Appendix A. Tables 4 identifies important summary statistics for the primary contaminant 1,3,5-Trinitrobenzene (TNB) at each collection point. Only one of four daily samples from

	Influent	C1/0	C2/0	C3/0	C4/0	C5/0	C6/0
Number of Samples	21	21	21	21	21	21	21
Mean	402.0	133.1	45.1	15.1	5.3	1.9	0.6
Standard Deviation	48.4	34.6	9.8	3.4	1.7	0.8	0.3
Range	172.0	143.6	36.4	11.1	5.4	3.3	1.3
Minimum	313.0	85.4	31.1	10.2	3.2	0.9	0.3
Maximum	485.0	229.0	67.5	21.3	8.6	4.2	1.6

Table 4. 1,3,5-Trinitrobenzene (TNB).

influent and effluent are used in contactor analysis. All four daily samples are used in effluent analysis. Similar summary statistic tables for TNT, RDX, and Total Nitrobenzenes are located in Appendix B. The table values are in $\mu\text{g} / \text{L}$ of groundwater. Figure 3 indicates a decreasing level of TNB from treatment within each contactor. Similar graphs for TNT, RDX, and Total Nitrobenzenes are given in Appendix B. The graph shows the

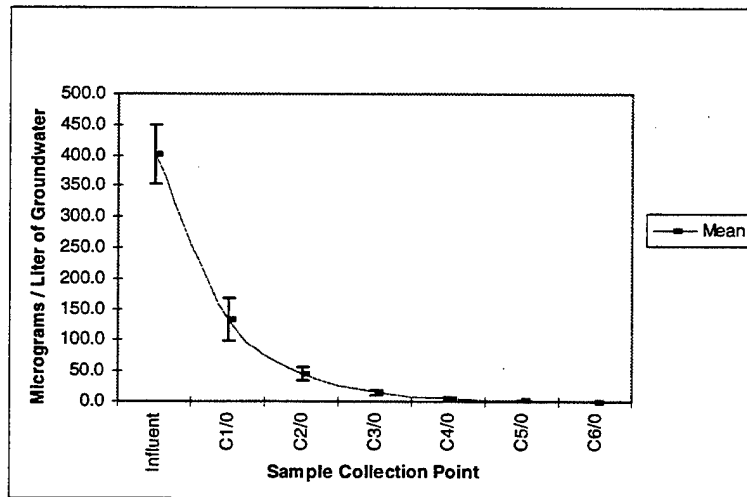

Figure 3. TNB Data Range for 13 gpm Flow Rate.

mean contaminant levels \pm one standard deviation at each contactor. An important point to note is the decrease in deviation at each contactor.

1. Effluent Analysis

Effluent analysis for the 13 gpm flow rate demonstration task indicates that all explosive contaminants treatment levels at sampling point C6/0 are below the treatment goals and NPDES standards. The requirements, established by USAEC, are for contaminants to meet treatment goals 90% of the time. Figure 4 summarizes the post treatment levels for each of the four specified contaminants compared to their respective

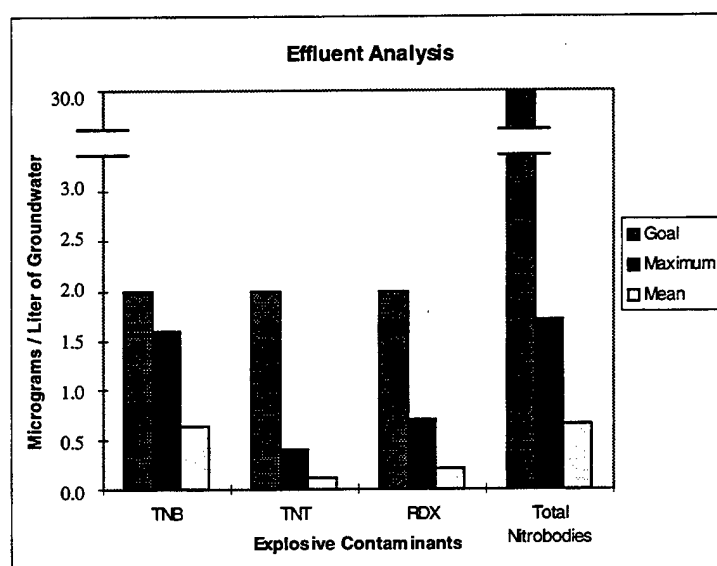

Figure 4. Effluent Analysis for 13 GPM Flow Rate.

goals. The maximum values out of sample size of 81 for each contaminant are well below the treatment goals for TNT, RDX and Total Nitrobenzenes. The maximum for TNB is also below the treatment goal. A table summarizing effluent levels for all contaminants against specified goals, including those for NPDES standards, is located in Appendix C.

2. Influent vs. Effluent Analysis

The comparisons between groundwater influent levels and the effluent levels are summarized in Table 5. The water sample sizes for this analysis consisted of 90 influent

	INFLUENT		EFFLUENT (C6/0)		RESPECTIVE
	Average	Standard Error	Average	Standard Error	BQL
1,3,5-TNB	400.806	6.433	0.643	0.030	N/A
2,4,6-TNT	441.578	9.745	0.105	0.004	0.1
2,4-DNT	11.107	0.229	0.400	0.000	0.4
2-amino-4,6-DNT	110.634	3.436	0.400	0.000	0.4
HMX	6.822	0.221	0.700	0.000	0.7
RDX	33.270	0.599	0.200	0.000	0.2
Total Nitrobenzenes	1010.386	18.724	0.647	0.035	N/A
Nitrate as Nitrogen	1.644	0.048	2.648	0.086	N/A

Table 5. Influent vs. Effluent for 13 gpm Flow Rate.

and 81 effluent samples. Table 5 also includes each contaminant's respective Below Quantitation Limit (BQL). In all samples for which a contaminant could not be detected, the contaminant concentration is set to the appropriate BQL by the laboratory. For example, even though the mean level of effluent for 2,4-DNT is 0.4; the fact that this is BQL and the standard error is 0.0 indicates that 2,4-DNT was not detected in any of the effluent samples and actual value of contaminant could be below the BQL. Those contaminants not listed were at their respective BQL at the influent. All contaminant levels decreased after PGTP treatment except for Nitrate as Nitrogen which increased but, still remained below the standards for NPDES.

3. Contactor Analysis

The primary contaminants for the contactor analysis are TNB, TNT, RDX and Total Nitrobenzenes. Figure 5 plots TNB contaminant levels versus each collection point.

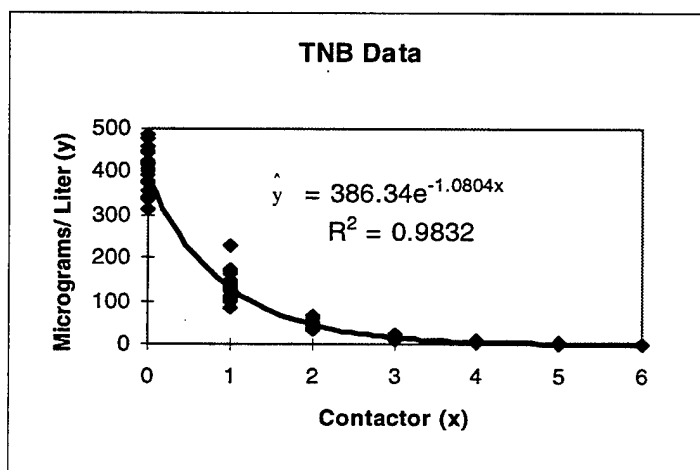

Figure 5. TNB Regression Analysis.

Regression analysis was used to determine a regression curve for contaminant level y as a function of the sample collection point x (where $x=0,1,..6$ represents collection at the influent, contactor C1/0,...contactor C6/0 respectively). The regression curve is located on the figure with the regression equation. The regression curve is fit using a model with exponential decay and multiplicative errors.

$$y = ae^{bx} \times \varepsilon$$

where a and b are the parameters and ε is the error term [Ref. 10: p. 163]. This model not only accounts for the nonlinear relationship between the contaminant level and contactor, it also models the decrease in variability in contaminant with each contactor number.

Figure 6 provides a graph of the regression curve with a 90% prediction interval. For the

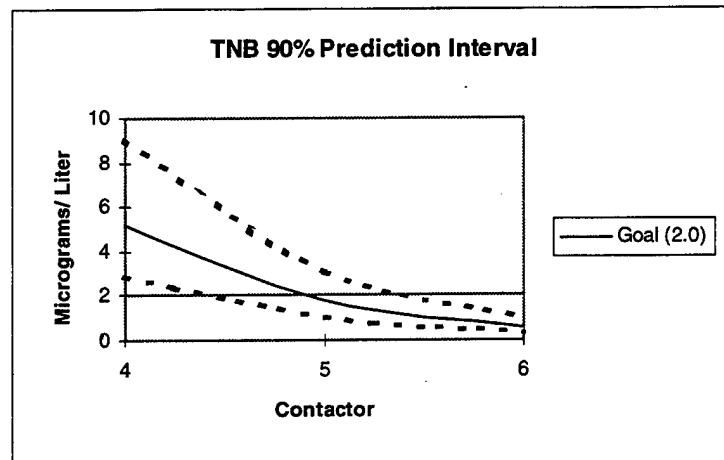

Figure 6. TNB Prediction Interval.

13 gpm flow rate demonstration, TNB does not reach the specified goal until after treatment in the sixth and final contactor with a 90% prediction interval. Similar figures for TNT, RDX, and Total Nitrobenzenes are located in Appendix C. Using the same 90% prediction interval, Total Nitrobenzenes and RDX meet treatment goals after the third contactor while TNT meets its goal at the fourth. The prediction interval provides USAEC with an anticipated contaminant level for TNB at treatment completion. At a 90% prediction interval, the upper limit for contactor 6 is $1.04 \mu\text{g} / \text{L}$ as seen in Figure 6.

For a more stringent 99% prediction interval, the upper limit for contactor 6 is only 1.34 $\mu\text{g} / \text{L}$ and still below required standards.

C. MAXIMUM FLOW RATE ANALYSIS

During the second part of the modified demonstration, the PGTP operated at a constant flow rate of 25 gpm. Diffuser inefficiency in each contactor and slight alterations of the PGTP by Montgomery Watson resulted in an H_2O_2 to O_3 ratio ranging from 0.50 to 0.53. Table 6 identifies important summary statistics for the primary contaminant TNB at each collection point. Again, only one of four daily influent and effluent samples are used for contactor analysis as identified in Table 6 to maintain sample consistency. Similar

	Influent	C1/0	C2/0	C3/0	C4/0	C5/0	C6/0
Number of Samples	20	20	20	20	20	20	20
Mean	343.8	151.6	69.9	28.3	12.1	5.4	2.3
Standard Deviation	54.1	22.5	10.4	5.4	2.1	1.2	0.5
Range	192.0	99.0	35.5	24.6	6.9	5.0	2.4
Minimum	254.0	106.0	56.0	18.9	8.2	3.1	1.4
Maximum	446.0	205.0	91.5	43.5	15.1	8.1	3.8

Table 6. 1,3,5-Trinitrobenzene (TNB).

summary statistics tables for TNT, RDX, and Total Nitrobenzenes are located in Appendix B. The tabled values are in $\mu\text{g} / \text{L}$ of groundwater. Figure 7 plots the mean contaminant level \pm one standard deviation at each contactor. The graph indicates that the level of

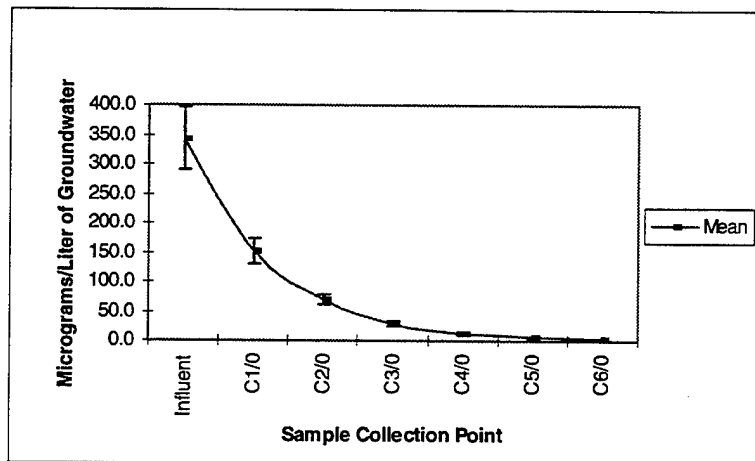

Figure 7. TNB Data Range for Maximum Flow Rate.

TNB decreases as it is treated by each contactor, similar to that of the 13 gpm flow rate demonstration. Also, a point to note is the decrease in variability of concentrations through each contactor. Similar graphs for TNT, RDX, and Total Nitrobenzenes are located in Appendix B.

1. Effluent Analysis

Effluent analysis for the maximum flow rate demonstration task indicate that the explosive contaminant TNB meets NPDES standards; but, it does not meet the treatment goal at sampling point C6/0, the final contactor. All other explosive contaminants are below the treatment goals. Figure 8 summarizes, from a sample size of 80, the post treatment levels for each of the four specified contaminants compared to their respective

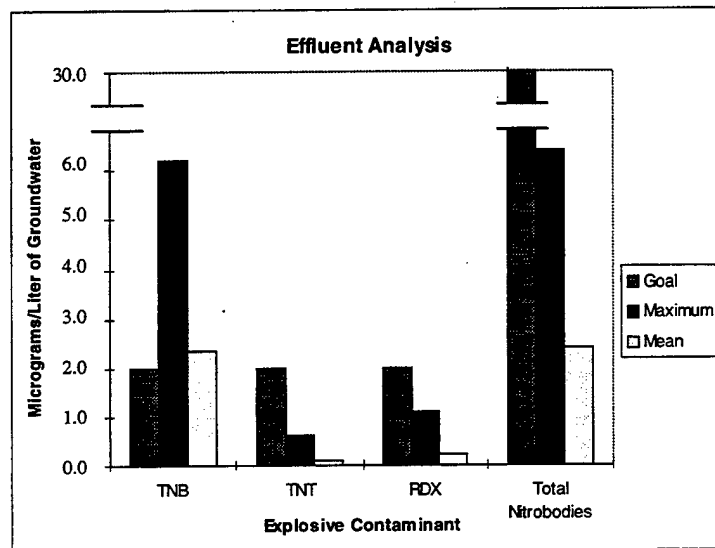

Figure 8. Effluent Analysis for Maximum Flow Rate.

goals. Again, with the exception of TNB, all maximum values are well below the treatment goals. The results from a statistical t-test strongly indicate (p-value = 0.00336) the mean of TNB is above the treatment goal of 2.0 µg / L of groundwater. For NPDES standards, the statistical t-test results strongly indicate (p-value = 0.0) the mean of TNB meets State standards.

2. Influent vs. Effluent Analysis

The comparisons between groundwater influent and effluent levels are summarized in Table 7. This table includes only those contaminants not at BQL at influent. The

	INFLUENT		EFFLUENT(C6/0)		RESPECTIVE
	Average	Standard Error	Average	Standard Error	BQL
1,3,5-TNB	346.340	5.671	2.345	0.258	N/A
2,4,6-TNT	312.080	6.426	0.108	0.006	0.1
2,4-DNT	9.719	0.148	0.400	0.000	0.4
2-amino-4,6-DNT	56.495	1.501	0.400	0.000	0.4
HMX	5.597	0.157	0.700	0.000	0.7
RDX	23.169	0.504	0.200	0.000	0.2
Total Nitrobodies	758.060	13.472	2.420	0.300	N/A
Nitrate as Nitrogen	0.901	0.036	1.495	0.037	N/A

Table 7. Influent vs. Effluent for Maximum Flow Rate.

standard error indicates large variability of contaminant levels at the influent point but very little variability at the effluent point. Zero standard errors are based on the BQL in which some contaminant levels could not be determined. As in the 13 gpm flow rate demonstration, all contaminants decrease in concentration except for Nitrate as Nitrogen. The effluent level for Nitrate as Nitrogen is well below the standards for NPDES.

3. Contactor Analysis

The data for the contactor analysis was collected over a span of twenty days. Figure 9 plots TNB contaminant levels after each contactor (0 = Influent, 1= C1/0, etc.) sampling. Regression analysis was used to determine a regression curve for contaminant levels in relation to sample collection points. The regression curve is again exponential with the equation located on the figure. The nonlinear model follows the form of the model in the 13 gpm flow rate contactor analysis. Figure 10 provides a graph of the regression curve for TNB with a 90% prediction interval. Similar figures for TNT, RDX, and total Nitrobodies are located in Appendix C. For the maximum flow rate demonstration, TNB does not meet the goal after the sixth contactor using a 90% prediction interval. Using the same prediction interval, RDX met its required goal after the third contactor while TNT and Total Nitrobodies met their respective goals after the

fourth. From the prediction interval, anticipated treatment levels for TNB will be above the target goal approximately 95% of the time.

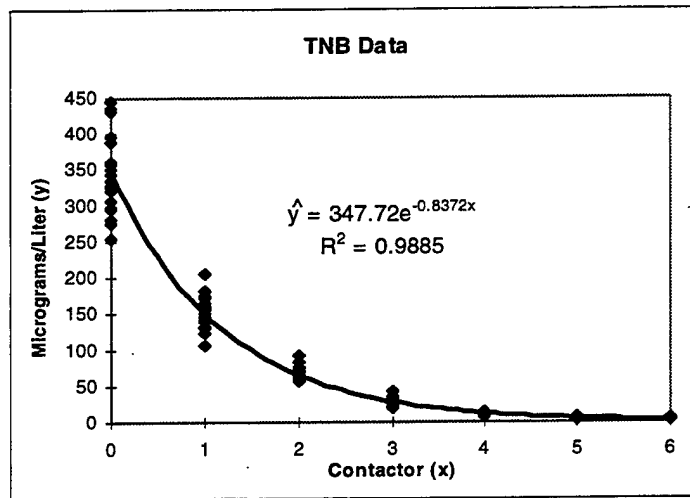

Figure 9. TNB Regression Analysis.

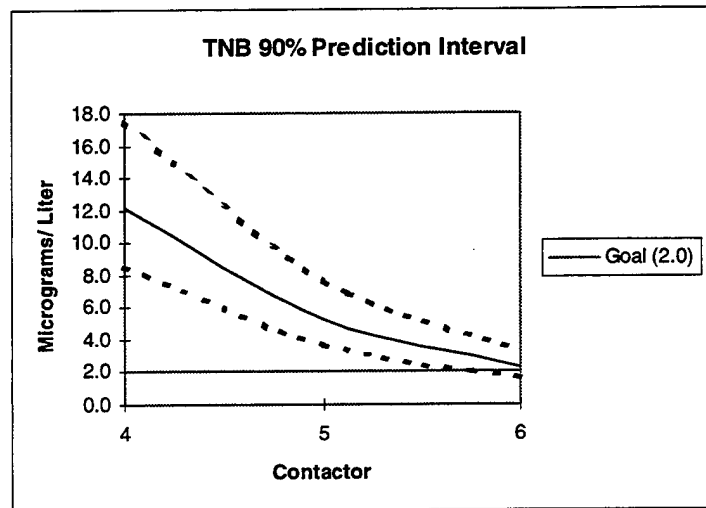

Figure 10. TNB Prediction Interval.

D. SUMMARY AND DISCUSSION OF DEMONSTRATION ANALYSIS

Based on results from the optimization phase of the demonstration, the PGTP was initially operated at a flow rate of 13 gpm, approximately 50% of contracted designed capacity, for a period of twenty-one days. This flow rate may not be the optimal flow rate

since no tests were conducted at flow rates between 17 and 14 gpm inclusively. The 13 gpm flow rate, however, is low enough to remove all contaminants below treatment goals. Instead of treating contaminants from a second well, a decision was made to run the PGTP at maximum flow rate for a period of twenty days. This resulted in a modified demonstration phase. Additionally, inefficiencies in the contactor bubble diffusers and slight PGTP adjustments by Montgomery Watson led to a high dosage ratio of H_2O_2 to O_3 per contactor in the range of 0.50 to 0.53 for maximum flow rate demonstration. At the maximum flow rate, 1,3,5-Trinitrobenzene (TNB) is not removed to the treatment goal of $2.0 \mu g / L$ of groundwater after contactor treatment. TNB, however, meets state NPDES standards and is removed to a concentration below the treatment goal after a subsequent GAC treatment.

Analysis for both the 13 gpm and maximum flow rate (25 gpm) demonstrations indicate that some explosive contaminants meet treatment goals prior to treatment by the final contactor. Figure 11 shows the first contactor (contactor 7 represents the GAC filter) at which the upper bound of a 90% prediction interval for the level of contaminant

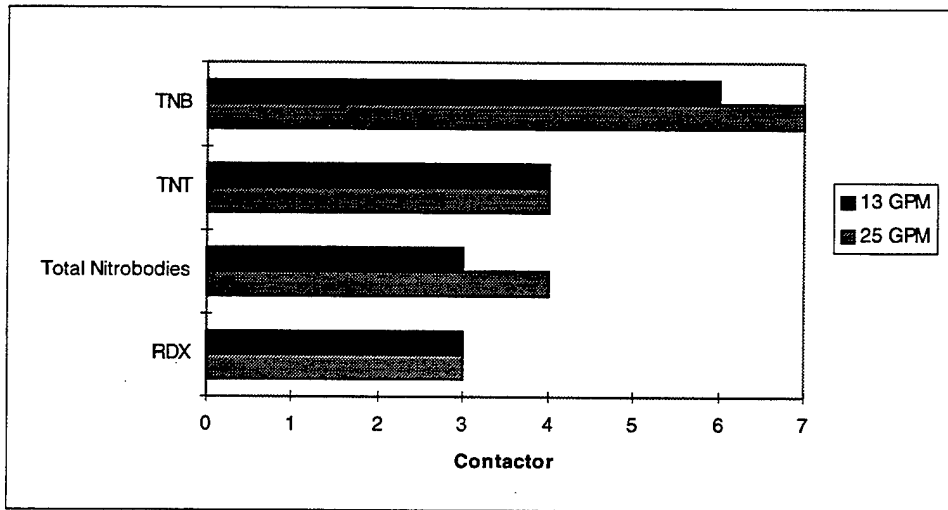

Figure 11. Contactor Treatment Results.

is below treatment goal. This result indicates a possible cost savings by reducing the number of contactors in the plant and then using additional GAC polishing to remove

contaminants left after *Peroxone* treatment. However, the cost savings involve tradeoffs and are not specifically discussed in this evaluation.

It should be noted that the results from this analysis pertain only to groundwater located at the Cornhusker Army Ammunition Plant (CAAP) and may not hold for other sites with higher levels of the specified explosive contaminants. However, assuming a constant chemical reaction rate during treatment, the relationship between chemical concentrations and contactors can be extrapolated for new concentrations at influent. This assumption shifts the regression curves so that the intercept (the concentration at influent) is set to the new level without changing the coefficient (b), the slope, in the nonlinear regression model. From the regression equations and the corresponding 90% prediction intervals, Table 8 provides the maximum allowable influent levels for each contaminant listed in micrograms per liter of groundwater. The number in parentheses next to tabled values refer to the contactor at which the contaminant is at BQL and can no

CONTAMINANT	13 GPM	25 GPM
TNB	1011.1	151.3
TNT	3,343.0 (4 th)	4,902.6 (5 th)
RDX	426.3 (4 th)	235.3 (4 th)
Total Nitrobodies	42,264.7	8,853.7

Table 8. Maximum Allowable Contaminant Levels.

longer be determined. For example, since TNT reached BQL at contactor 4, the maximum allowable influent is calculated for that contactor. TNT and RDX can have higher maximum allowable values since treatment occurs in final contactors; but, they must not drive Total Nitrobodies above its maximum value.

Another limitation of the evaluation results from the time period of the demonstration. The contract with the USAEC for the *Peroxone* demonstration expires in March, 1997. This equates to a deadline for all final analysis and reports on *Peroxone* suitability and usefulness in future applications. In addition, any data collection or demonstrations conducted in mid to late November in Nebraska are subject to cancellation

due to harsh weather conditions. This constraint set the “must complete by” date of 8 November, 1996. The actual demonstration lasted for a period of 8 weeks. Seasonable temperature and weather conditions remained relatively constant. PGTP effectiveness comparisons between winter versus summer months, dry periods versus excessive rain/snow, and with temperature variations are not available.

IV. COST ANALYSIS

Cost comparisons are based on estimates of 30 year Life Cycle Costs (LCC) for the groundwater treatment methods. All costs are from bench scale demonstrations of the comparing technologies and not full scale plants. The LCC is partitioned into capital costs and annual operating costs. Capital costs are initial, up front costs associated with purchasing the equipment and materials required for plant construction. Operating costs are the recurring (consumable) costs associated with plant operation such as chemical usage, parts, and labor. In addition to the LCCs, a dollar/thousand gallons (\$/1000 gal) of treated groundwater is provided as an alternative method for comparing costs. All dollar values are in terms of constant dollars (FY '97 dollars). An inflation index of 5.25% is assumed with a base year of 1995.

A. GAC COST ESTIMATES

“Granular Activated Carbon (GAC) absorption has the longest history, and is the most mature method used today for the removal of organic materials from wastewater” [Ref. 11:p. 15]. The greatest drawback of the GAC method is that GAC requires further treatment once it is saturated with explosive contaminants. This requirement stems from the categorization of “spent carbon from the treatment of waste water containing explosives” as hazardous waste number K045 under Hazardous Waste as defined in the Code of Federal Regulations [Ref. 11:p. 10].

Two methods currently used for the additional treatment of the “explosive-laden GAC” [Ref. 11:p. 5] are thermal regeneration or incineration. The GAC method is separated into two estimates providing a cost for GAC using thermal regeneration and a cost for GAC using incineration. The cost estimates are summaries of the National Defense Center for Environmental Excellence (NDCEE) report on Pink Water Treatment

Options (May 5 1995). Complete cost data for the two estimates, in FY95 dollars, are located in Appendix D.

1. GAC /Thermal Regeneration Cost Estimate

Thermal regeneration, the most common method of reactivating GAC, has had varying success at Department of Defense (DoD) facilities. Current regeneration methods result in less effective GAC than virgin GAC. Some GAC regeneration methods reduce GAC to as much as 50% of its original effectiveness. [Ref. 11:p. 16]

Regeneration methods are divided into two categories, on-site and off-site. On-site regeneration requires the inclusion of a regeneration system in treatment plant design and operation. Off-site regeneration requires the shipment of the hazardous waste K045 to an alternate location. Despite the decrease in GAC effectiveness, "off-site regeneration has proven to be the most economical for most of the Army installations that are currently generating this spent GAC" [Ref. 6:p. 1-1]. The GAC estimate for one time capital costs and annual operating costs for one year shown in Table 9 is based on a flow rate of 20 gpm and off-site regeneration of spent GAC.

CATEGORY	COST \$ (FY95)	COST \$ (FY97)
CAPITAL COSTS	159,900	177,130
OPERATING COSTS	30,706	34,014

Table 9. GAC/Thermal Regeneration Costs Inflation Adjusted.

2. GAC/Incineration Cost Estimate

GAC incineration, an alternate method to regeneration, requires the burning of "explosive-laden GAC" as fuel in boilers and cement kilns. GAC incineration is also divided into on-site or off-site methods. Off-site methods are often more cost effective. Due to strict air quality regulations, scrubbers are installed on the incineration equipment to reduce the air pollution. "Incineration is expensive, permitting can be difficult, and scrubber waste can be problematic." [Ref. 11: pp. 5-6] The GAC estimate for capital and

annual operating costs shown in Table 10 is based on a flow rate of 20 gpm and off-site incineration of spent GAC.

CATEGORY	COST \$ (FY95)	COST \$ (FY97)
CAPITAL COSTS	159,900	177,130
OPERATING COSTS	48,106	53,290

Table 10. GAC/Incineration Costs.

B. UV/OX COST ESTIMATE

The Ultraviolet/Ozone (UV/OX) process is included in the class of Advance Oxidation Process (AOP) technologies as is *Peroxone*. By producing hydroxyl radicals, the explosive contaminants are decomposed into harmless byproducts, thus eliminating the need for additional hazardous waste treatment. In 1994, WESTON, at the direction of USAEC, selected four vendors (Purifics Environmental Technologies, Solarchem Environmental Systems, Ultrox International, and Vulcan Peroxidation Systems Incorporated (VPSI)) to participate in a bench-scale and pilot-scale demonstration. All vendors proved the UV/OX method was effective in reducing explosive contaminated groundwater. A detailed description of the demonstration and UV/OX technology is located in WESTON's Final Report to USAEC [Ref. 6].

WESTON ranked the system designed by Ultrox International as number one in demonstration results and the lowest capital and annual operating costs estimate. The Ultrox system is currently installed in the UV/OX treatment plant at Milan, Tennessee. The cost estimate in WESTON [Ref. 6] is based on a flow rate of 50 gpm. To standardize the flow rates to 20 gpm for eight hours a day and 250 days a year, the rate of the two GAC estimates, scaling methods are used to adjust the cost estimate.

The complete cost estimate data for the full scale Ultrox UV/OX system without Manganese Reduction [Ref. 6] is based on operating the plant 24 hours a day, 365 days a year, at a flow rate of 50 gpm. The estimated Total Capital Costs and Total Annual

Operating Costs are \$393,000 and \$96,822 respectively. Table 11 gives Annual Operating Costs [Ref. 6: Appendix D] by type of consumable.

Consumable	Units	Cost (\$/unit)	Average Units/1000gallons	Gallons/Day	Cost \$/day	Cost \$/yr
Electricity	kWh	\$0.06	40.8	72,000	\$176.26	\$64,333.44
NaOH	lbs	\$0.10	0.1681	72,000	\$1.21	\$441.77
H2SO4	lbs	\$0.07	2.9495	72,000	\$14.87	\$5,425.90
UV Lamps	lamps	\$50.00	NA	72,000	\$68.49	\$25,000.00
Air Filters	filters	\$30.00	NA	72,000	\$0.74	\$270.10
Compressor Filter	filters	\$100.00	NA	72,000	\$0.27	\$100.00
Compressor Oil	volumes	\$50.00	NA	72,000	\$0.14	\$50.00
Upsets/Restarts	no.occurrences	\$0.00	0	72,000	\$0.00	\$0.00
Down Time	minutes	\$0.00	0	72,000	\$0.00	\$0.00
UV/OX Labor	minutes	\$0.248	0.0059	72,000	\$0.11	\$38.45
Pre/Post Treat Labor	minutes	\$0.248	0.14	72,000	\$2.50	\$912.44
Lamp Replacement Labor	minutes	\$0.248	NA	72,000	\$0.68	\$249.98
Totals					\$265.26	\$96,822.08

Table 11. UV/OX Annual Operating Costs From Ref. 6.

To provide a standard cost estimate for a simplified cost comparison, adjustments are made to both the capital and operating costs. Two methods are used to rescale the cost data. For consumables, where the average amount consumed per 1000 gallons of water treated is available in Table 11, the costs are adjusted by simply replacing 72,000 gallons per day (gpd) based on 50 gpm for 24 hours with 9,600 gpd based on 20 gpm for 8 hours, and by multiplying the cost per day (Cost \$/day) by 250 days instead of 365 to obtain the cost per year. The remaining consumables and the capital costs are scaled using the Chemical Engineering Scaling Formula below [Ref. 12]:

$$COST_{Adjusted} = COST_{Previous} * \left(\frac{Adjusted\ Flow\ in\ gpm}{Previous\ Flow\ in\ gpm} \right)^{0.6}$$

The UV/OX estimate for capital and annual operating costs, summarized in Table 12, are based on a flow rate of 20 gpm and incorporation of the Ultrox System. Table 13 gives a breakdown of consumables associated with the scaled flow rate estimate.

CATEGORY	COST \$ (FY95)	COST \$ (FY97)
CAPITAL COSTS	226,792	251,230
OPERATING COSTS	21,310	23,606

Table 12. UV/OX (Ultrox) Costs Inflation Adjusted.

Consumable	Units	Cost (\$/unit)	Average Units/1000gallons	Gallons/Day	Cost \$/day	Cost \$/yr
Electricity	kWh	\$0.06	40.8	9,600	\$23.50	\$5,875.20
NaOH	lbs	\$0.10	0.1681	9,600	\$0.16	\$40.34
H2SO4	lbs	\$0.07	2.9495	9,600	\$1.98	\$495.52
UV Lamps	lamps	\$50.00	NA	9,600	NA	\$14,426.00
Air Filters	filters	\$30.00	NA	9,600	NA	\$155.81
Compressor Filter	filters	\$100.00	NA	9,600	NA	\$57.70
Compressor Oil	volumes	\$50.00	NA	9,600	NA	\$28.85
Upsets/Restarts	no.occurrences	\$0.00	0	9,600	\$0.00	\$0.00
Down Time	minutes	\$0.00	0	9,600	\$0.00	\$0.00
UV/OX Labor	minutes	\$0.248	0.0059	9,600	\$0.01	\$3.51
Pre/Post Treat Labor	minutes	\$0.248	0.14	9,600	\$0.33	\$83.33
Lamp Replacement Labor	minutes	\$0.248	NA	9,600	NA	\$144.25
Totals					\$85.24	\$21,310.51

Table 13. UV/OX Adjusted Annual Operating Costs After Ref. 6.

C. PEROXONE COST ESTIMATE

Two capital and annual operating costs estimates are computed for the *Peroxone* groundwater treatment method. The first estimate, GAC MINUS, is based on the 13 gpm flow rate demonstration in which treatment levels were met without need for additional GAC treatment. The second estimate, GAC PLUS, is based on the maximum (25 gpm) flow rate demonstration in which GAC was required to lower TNB to treatment goals. The complete cost data and calculations for the two *Peroxone* estimates are located in Appendix E. Adjustments for inflation are not required since cost data collection occurred in FY 97.

1. GAC MINUS Cost Estimate

Prior to comparing the *Peroxone* process at this flow rate (13 gpm) to the alternative methods, the capital and operating costs are adjusted as in the previous section to a 20 gpm flow rate. At the 13 gpm flow rate, an indirect relationship exists between the flow rate and the chemical dosages required for treatment. The chemical dosages, in turn, have a direct relationship to cost. The cost cannot be estimated just by increasing the flow rate of the same PGTP. An estimate must be made on a larger scale treatment plant. Table 14 provides the capital and annual operating costs for the scaled 13 gpm flow rate.

CATEGORY	COST \$ (FY97)
CAPITAL COSTS	170,376
OPERATING COSTS	28,200

Table 14. *Peroxone* GAC MINUS Costs.

2. GAC PLUS Cost Estimate

The additional requirement for GAC to decrease TNB below treatment goal is the basis for this estimate. Again, scaling methods are required to compare capital and operating costs for the maximum (25 gpm) flow rate to the GAC and UV/OX estimates at the 20 gpm flow rate. Table 15 provides the capital and annual operating costs for the scaled maximum (25 gpm) flow rate.

CATEGORY	COST \$ (FY97)
CAPITAL COSTS	115,083
OPERATING COSTS	17,792

Table 15. *Peroxone* GAC PLUS Costs.

D. COST ESTIMATE COMPARISON

The Life Cycle Costs (LCC) for each treatment process is determined using Present Value (PV) based on FY 97. Present Value, also known as discounting, provides the investor (in this case USAEC) the cost of the treatment process over a set number of years in terms of today's dollar [Ref. 13:p. 612]. The 30 year life cycle costs in Table 16 are based on "the Government method of economic evaluation including long term bond discount rates (eight percent), and exclusion of" depreciation, insurance, setup and demobilization, and overhead costs [Ref. 11:p. 63]. The results of the LCC calculations, for this demonstration, indicate both *Peroxone* estimates have lower LCC than existing treatment processes. The *Peroxone* GAC PLUS Life Cycle Cost, however, is almost 43% less than the cheapest GAC process using thermal regeneration and just over 38% less than the UV/OX process.

TREATMENT PROCESS	CAPITAL COSTS (\$, PV)	OPERATING LCC (\$, PV)	TOTAL 30 YR LIFE CYCLE COST
GAC/Thermal Regeneration	177,130	382,922	560,052
GAC/Incineration	177,130	599,927	777,057
UV/OX	251,230	265,751	516,981
Peroxone GAC MINUS	170,376	317,474	487,849
Peroxone GAC PLUS	115,083	200,299	315,381

Table 16. 30 Year Life Cycle Costs After Ref. 11.

For an alternate cost comparison method, a ratio (\$/1000 gal) is calculated for one year's annual operating cost per gallons treated. Capital costs are not addressed in the calculations. Table 17 provides the results for the alternate method.

TREATMENT PROCESS	ANNUAL OP COST	1000 GALLONS TREATED/YR	COST RATIO (\$/1000 GALLONS)
GAC/Thermal Regeneration	34,014	2,400	14.17
GAC/Incineration	53,290	2,400	22.20
UV/OX	23,606	2,400	8.84
Peroxone GAC MINUS	28,200	2,400	11.75
Peroxone GAC PLUS	17,792	2,400	7.41

Table 17. Alternate Cost Comparison.

The results from both cost estimates indicate that *Peroxone* GAC PLUS (maximum flow rate) is the cheapest method for treatment of the explosive contaminants TNB, TNT, RDX, and Total Nitrobenzenes. The key cost factor in the high annual operating cost for the *Peroxone* GAC Minus estimate is the amount of O₂ required to produce the ozone. At a flow rate of 13 gpm, the cost for O₂ is \$7.75 per 1000 gallons of groundwater; whereas, for the 25 gpm flow rate, the cost is only \$3.09 per 1000 gallons of groundwater. The difference in the amount of H₂O₂ is only \$1.09 per 1000 gallons.

V. CONCLUSIONS AND RECOMMENDATIONS

A. CONCLUSIONS

The *Peroxone* Groundwater Treatment Plant (PGTP) is effective in decreasing all explosive contaminants of interest, with the exception of 1,3,5-Trinitrobenzene (TNB), to USAEC treatment targets at the maximum (25 gpm) designed flow rate. TNB, however, meets NPDES standards. Some explosive contaminants are reduced below treatment goals before the groundwater is treated in the final contactor. TNB requires additional treatment using the GAC polishing system to meet the treatment goal. At a flow rate of only 13 gpm, approximately 50% of the contracted design capacity of the PGTP, TNB meets the goal without a need for GAC polishing. It must be noted that the effectiveness of the *Peroxone* treatment from this analysis pertains only to groundwater located at the Cornhusker Army Ammunition Plant (CAAP) and may not hold for contaminant levels found at other locations.

The two life cycle cost estimates for the *Peroxone* process, based on the 13 gpm and 25 gpm flow rate demonstrations, indicate possible cost savings over the existing treatment processes. The estimate for the 25 gpm demonstration, however, represents a considerable cost savings of up to 43% over the cheapest GAC process and 38% over the UV/OX process. Even though the 25 gpm flow rate required a follow-up GAC treatment to reduce TNB to treatment goal, the significantly lower H₂O₂ and O₂ costs at the higher flow rate more than offset the GAC costs. Design corrections to improve the efficiency of the contactor diffusers will further decrease the dosage levels of H₂O₂ and O₂ required resulting in even lower annual operating costs for both estimates.

B. RECOMMENDATIONS

The CAAP demonstration of Montgomery Watson's PGTP provides evidence that *Peroxone* is a viable process for the removal of TNB, TNT, RDX, and Total Nitrobenzenes.

If the primary concern for a full scale treatment plant is the requirement to remove contaminants without need for additional waste treatment (i.e., GAC regeneration or incineration), then use the results from the 13 gpm flow rate demonstration as the base model. However, If the primary concern is cost, then use the results from the maximum flow rate demonstration as the base model. Perhaps a more cost effective *Peroxone* process may include the removal of some contactors from the plant in favor of follow on GAC treatment as indicated by the removal of some contaminants at the third, fourth, and fifth contactors. This involves some tradeoff analysis and would be beneficial if time and budget limitations warranted such a study.

APPENDIX A. RAW DATA

This Appendix contains the raw data for contactor analysis for each task of the demonstration.

A. 13 GPM FLOW RATE DEMONSTRATION

Sample Date	Influent	C1/0	C2/0	C3/0	C4/0	C5/0	C6/0
13-Sep	313	104	31.1	11.1	3.3	1.1	0.4
14-Sep	475	170	60	19.5	5.1	2.2	0.8
15-Sep	338	96.6	41.1	10.5	3.5	1.2	0.5
16-Sep	444	133	40	15.8	4.6	1.6	0.4
17-Sep	402	114	37.8	12.6	4.3	1.5	0.5
18-Sep	380	99.4	38.2	13	3.4	1.2	0.4
23-Sep	419	147	59.6	17.6	7.9	2.6	0.9
24-Sep	460	135	36.6	10.2	3.4	0.9	0.3
25-Sep	379	85.4	41.5	17	4.4	1.8	0.4
26-Sep	485	164	49.2	18.8	7.9	2.9	1
27-Sep	446	173	59.4	17	8.6	4.2	1.6
28-Sep	392	229	45.2	18.5	7.3	2.4	0.9
29-Sep	376	150	67.5	21.3	6.9	2	0.6
30-Sep	448	168	47.5	15.2	5.9	2.9	0.8
1-Oct	353	135	45.1	20.1	6	2.3	0.8
2-Oct	426	99.8	40.1	10.6	3.2	1	0.4
7-Oct	408	100	34.7	12.9	4.9	1.5	0.5
8-Oct	408	120	43.8	15.9	5	2.1	0.6
9-Oct	335	127	53.2	13.7	6.3	1.8	0.6
10-Oct	414	106	34.1	12	3.8	1.5	0.6
11-Oct	341	138	42.1	14.5	4.8	1.7	0.6

Table 18. TNB Concentrations ($\mu\text{g} / \text{L}$).

Sample Date	Influent	C 1/0	C 2/0	C 3/0	C 4/0	C 5/0	C 6/0
13-Sep	642	67.2	8.8	1.4	0.2	0.1	0.1
14-Sep	661	114	21.6	4.2	0.4	0.1	0.1
15-Sep	462	56.2	9.9	1.2	0.2	0.1	0.1
16-Sep	456	72.7	9.8	1.7	0.2	0.1	0.1
17-Sep	475	65.6	9.5	1.5	0.2	0.2	0.1
18-Sep	409	53.8	8.9	1.4	0.2	0.1	0.1
23-Sep	465	83.1	16.5	1.9	0.4	0.1	0.1
24-Sep	531	71.1	9	1	0.2	0.1	0.1
25-Sep	416	44.2	10.5	2.1	0.2	0.1	0.1
26-Sep	343	88.8	11.4	1.8	0.3	0.1	0.1
27-Sep	381	87.8	12.6	1.5	0.3	0.1	0.1
28-Sep	403	116	11.4	1.7	0.3	0.1	0.1
29-Sep	394	74.2	14.6	2.3	0.3	0.1	0.1
30-Sep	432	84.2	9.1	1.3	0.2	0.1	0.1
1-Oct	348	63.4	9.7	2.3	0.4	0.1	0.1
2-Oct	448	53.5	8	1.1	0.3	0.1	0.1
7-Oct	429	50.2	7.4	1.1	0.2	0.1	0.1
8-Oct	395	53.3	11	1.5	0.2	0.1	0.1
9-Oct	320	58.1	9.6	1.2	0.3	0.1	0.1
10-Oct	379	45.1	7.9	1.1	0.1	0.1	0.1
11-Oct	318	59.7	8.4	1.2	0.1	0.1	0.1

Table 19. TNT Concentrations ($\mu\text{g} / \text{L}$).

Sample Date	Influent	C 1/0	C 2/0	C 3/0	C 4/0	C 5/0	C 6/0
13-Sep	43.9	14.3	1.4	0.4	0.2	0.2	0.2
14-Sep	43.4	8.7	1.1	0.2	0.2	0.2	0.2
15-Sep	41.1	10.6	1.5	0.2	0.2	0.2	0.2
16-Sep	40.3	8.6	1.5	0.5	0.2	0.2	0.2
17-Sep	29.7	7.7	1.4	0.2	0.2	0.2	0.2
18-Sep	32.5	7.8	1.4	0.3	0.2	0.2	0.2
23-Sep	36.1	9.9	2.2	0.2	0.2	0.2	0.2
24-Sep	36	8.2	1.4	0.2	0.2	0.2	0.2
25-Sep	35.2	8.4	1.7	0.9	0.2	0.2	0.2
26-Sep	29.5	10.3	1.5	0.3	0.2	0.2	0.2
27-Sep	33.9	9.7	1.9	0.4	0.2	0.2	0.2
28-Sep	36.5	8.8	1.7	0.2	0.2	0.2	0.2
29-Sep	29.7	8.3	2	0.4	0.2	0.2	0.2
30-Sep	33.6	9.6	1.4	0.2	0.2	0.2	0.2
1-Oct	30.7	8	1.4	0.9	0.2	0.2	0.2
2-Oct	35.1	7.3	1.5	0.2	0.2	0.2	0.2
7-Oct	34.6	6	1.1	0.3	0.2	0.2	0.2
8-Oct	29.4	7.5	1.6	0.2	0.2	0.2	0.2
9-Oct	30.5	9.2	1.6	0.2	0.2	0.2	0.2
10-Oct	29	5.8	1.3	0.2	0.2	0.2	0.2
11-Oct	22.6	6.7	1.2	0.3	0.2	0.2	0.2

Table 20. RDX Concentrations ($\mu\text{g} / \text{L}$).

Sample Date	Influent	C1/0	C2/0	C3/0	C4/0	C5/0	C6/0
13-Sep	1370	192	43.1	13.9	3.5	1.1	0.4
14-Sep	1410	300.3	85.9	25.6	6.6	3.1	1.3
15-Sep	1050	179	54.4	13	4.6	1.7	0.5
16-Sep	1020	219	53.1	19.4	5.7	1.6	0.4
17-Sep	1040	192	50.6	14.1	4.5	1.7	0.5
18-Sep	958.5	165.3	50.1	15.5	3.6	1.2	0.4
23-Sep	1080	246	81.2	20.7	9	3	0.9
24-Sep	1190	220	48.8	12	4.1	0.9	0.3
25-Sep	968	142	55.6	21	4.6	1.8	0.4
26-Sep	791.9	268	63.9	21.9	8.8	2.9	1
27-Sep	868	276	76.2	19.8	9.5	4.2	1.6
28-Sep	957	359	60.3	21.3	8.1	2.4	0.9
29-Sep	916	238	86.3	25	7.8	2	0.6
30-Sep	1040	267	59.8	17.5	6.6	2.9	0.8
1-Oct	845	211	57.9	24.5	7	2.3	0.8
2-Oct	1030	165	51.3	12.5	3.9	1	0.4
7-Oct	1000	160	44.7	15.1	5.6	1.5	0.5
8-Oct	946	186	58.5	18.3	5.8	2.1	0.6
9-Oct	795	199	66.2	15.7	6.6	1.8	0.6
10-Oct	927	161	45	14	3.9	1.5	0.6
11-Oct	758	208	53.7	16.8	5.3	2.1	0.6

Table 21. Total Nitrobodyes Concentrations ($\mu\text{g} / \text{L}$).

B. MAXIMUM FLOW RATE DEMONSTRATION

Sample Date	Influent	C1/0	C2/0	C3/0	C4/0	C5/0	C6/0
12-Oct	388	160	91.5	43.5	15.1	8.1	3.8
13-Oct	396	150	91.3	33.1	14.6	6.5	2.6
14-Oct	351	173	75.1	29	13.7	6	2.8
15-Oct	335	205	70.7	35.8	13.5	5.2	2.4
16-Oct	430	181	63.5	27.6	13.3	5.4	2.3
21-Oct	446	156	61.1	28.1	13.1	5.8	2
22-Oct	361	140	75.5	28.2	13	5.6	2.6
23-Oct	435	158	67.5	27.4	12.7	5.6	2.6
24-Oct	352	165	66.5	29.6	15.1	6.3	2.8
25-Oct	320	157	72.9	28.1	11.9	5.2	2.5
26-Oct	344	130	56	32.6	10.2	4.6	2.3
27-Oct	307	142	57.2	18.9	8.2	3.1	1.4
28-Oct	327	157	60.3	23.6	14.2	8	2.3
29-Oct	358	175	64.7	22.1	13.4	5.8	2.3
30-Oct	326	146	76.2	26.9	11.5	5.1	2
4-Nov	296	133	71.9	31.4	9.7	4.4	2
5-Nov	254	106	58.6	25	11	5.3	2.1
6-Nov	294	145	81.5	27.9	10.6	4.3	2.4
7-Nov	276	122	59.8	25.7	9.7	4.5	2
8-Nov	280	130	76.4	21.3	8.3	3.7	1.6

Table 22. TNB Concentrations ($\mu\text{g} / \text{L}$).

Sample Date	Influent	C 1/0	C 2/0	C 3/0	C 4/0	C 5/0	C 6/0
12-Oct	366	78.9	21.6	4.7	0.9	0.3	0.1
13-Oct	396	72.7	20.8	4.4	0.9	0.2	0.1
14-Oct	352	82.2	19.9	3.9	0.08	0.2	0.1
15-Oct	301	100	15.8	4	0.7	0.1	0.1
16-Oct	416	83.9	14.2	3	0.7	0.1	0.1
21-Oct	446	80	15.4	3.3	0.7	0.1	0.1
22-Oct	320	70.6	18.3	3.3	0.7	0.1	0.1
23-Oct	393	73.2	15.9	3.1	0.7	0.2	0.1
24-Oct	321	77.4	15.4	3.4	0.8	0.2	0.1
25-Oct	284	70.3	16.6	3	0.6	0.1	0.1
26-Oct	298	57.3	13	3.6	0.6	0.1	0.1
27-Oct	263	65.6	13.1	2.1	0.4	0.1	0.1
28-Oct	275	69.1	13.4	2.5	0.7	0.2	0.1
29-Oct	294	75.5	14	2.2	0.7	0.1	0.1
30-Oct	292	60	13.4	2.6	0.5	0.1	0.1
4-Nov	268	54.9	13.5	3.6	0.4	0.1	0.1
5-Nov	198	45.6	11.7	2.5	0.5	0.1	0.1
6-Nov	258	63.7	15.2	3	0.5	0.1	0.1
7-Nov	235	52.4	11.4	2.7	0.5	0.1	0.1
8-Nov	235	54.4	14	2.2	0.4	0.1	0.1

Table 23. TNT Concentrations ($\mu\text{g} / \text{L}$).

Sample Date	Influent	C 1/0	C 2/0	C 3/0	C 4/0	C 5/0	C 6/0
12-Oct	36.1	10.9	3.2	0.9	0.3	0.2	0.2
13-Oct	28.8	11.4	3.4	0.7	0.2	0.2	0.2
14-Oct	23.2	9	3.2	0.7	0.2	0.2	0.2
15-Oct	22.9	9.9	2.6	0.9	0.2	0.2	0.2
16-Oct	25.7	8.3	2.2	0.7	0.2	0.2	0.2
21-Oct	30	9	2.3	0.9	0.2	0.2	0.2
22-Oct	23.6	8.8	2.7	0.7	0.2	0.2	0.2
23-Oct	26.8	8	2.3	0.8	0.2	0.2	0.2
24-Oct	25.3	8.6	2.3	0.6	0.2	0.2	0.2
25-Oct	23.7	7.9	2.4	0.5	0.2	0.2	0.2
26-Oct	20.7	6.6	1.8	0.6	0.2	0.2	0.2
27-Oct	20.1	8.6	1.9	0.3	0.2	0.2	0.2
28-Oct	21.9	7.5	1.9	0.4	0.2	0.2	0.2
29-Oct	19.7	8	2	0.4	0.2	0.2	0.2
30-Oct	18.2	6.7	1.9	0.4	0.2	0.2	0.2
4-Nov	25.7	6.6	2	0.6	0.2	0.2	0.2
5-Nov	19.7	5	1.8	0.4	0.2	0.2	0.2
6-Nov	19.3	7.3	2.1	0.6	0.2	0.2	0.2
7-Nov	18	5.7	1.6	0.5	0.2	0.2	0.2
8-Nov	18.5	5.7	2.1	0.4	0.2	0.2	0.2

Table 24. RDX Concentrations ($\mu\text{g} / \text{L}$).

Sample Date	Influent	C 1/0	C 2/0	C 3/0	C 4/0	C 5/0	C 6/0
12-Oct	896	256	119	50.7	17.3	9	3.8
13-Oct	927	241	119	40	16.7	6.7	2.6
14-Oct	820	270	101	35.2	15.3	6.7	2.8
15-Oct	731	318	91	42	14.7	5.9	2.4
16-Oct	952	278	82.4	32.8	14.2	5.5	2.3
21-Oct	1030	251	81.7	34	13.8	5.9	2
22-Oct	786	225	99.4	33.7	14.8	5.7	2.6
23-Oct	944	244	88.5	33	14.5	6.5	2.6
24-Oct	784	256	86.9	35.2	17	7.2	2.8
25-Oct	703	240	94.5	33.1	13.5	6	2.5
26-Oct	730	199	73.1	38.1	11.6	5.2	2.3
27-Oct	650	221	74.5	22.4	9.3	3.5	1.4
28-Oct	687	238	77.9	27.8	15.9	8.6	2.3
29-Oct	739	264	83.4	25.7	14.9	5.9	2.3
30-Oct	689	217	93.8	31.2	12.4	5.1	2
4-Nov	672	199	90	37.2	10.1	4.5	2
5-Nov	535	205	74	29	12.2	5.4	2.1
6-Nov	637	220	101	32.8	11.1	4.3	2.4
7-Nov	583	184	74.8	30	10.2	4.5	2
8-Nov	594	194	94.6	25.2	9.5	3.7	1.6

Table 25. Total Nitrobody Concentrations ($\mu\text{g} / \text{L}$).

APPENDIX B. DEMONSTRATION RESULTS

This appendix provides important summary statistics, in $\mu\text{g} / \text{L}$ of groundwater, for TNT, RDX, and Total Nitrobenzenes for each task of the demonstration.

A. 13 GPM FLOW RATE DEMONSTRATION

The optimal flow rate demonstration consisted of running the PGTP at a flow rate of 13 gpm, a transferred O_3 dosage of 80 mg/L of groundwater per contactor, and an H_2O_2 dosage of 24 mg/L of groundwater per contactor.

	Influent	C1/0	C2/0	C3/0	C4/0	C5/0	C6/0
Number of Samples	21	21	21	21	21	21	21
Mean	433.7	69.6	10.7	1.6	0.2	0.1	0.1
Standard Deviation	89.8	20.1	3.3	0.7	0.1	0.0	0.0
Range	343.0	71.8	14.2	3.2	0.3	0.1	0.0
Minimum	318.0	44.2	7.4	1.0	0.1	0.1	0.1
Maximum	661.0	116.0	21.6	4.2	0.4	0.2	0.1

Table 26. 2,4,6-Trinitrotoluene.

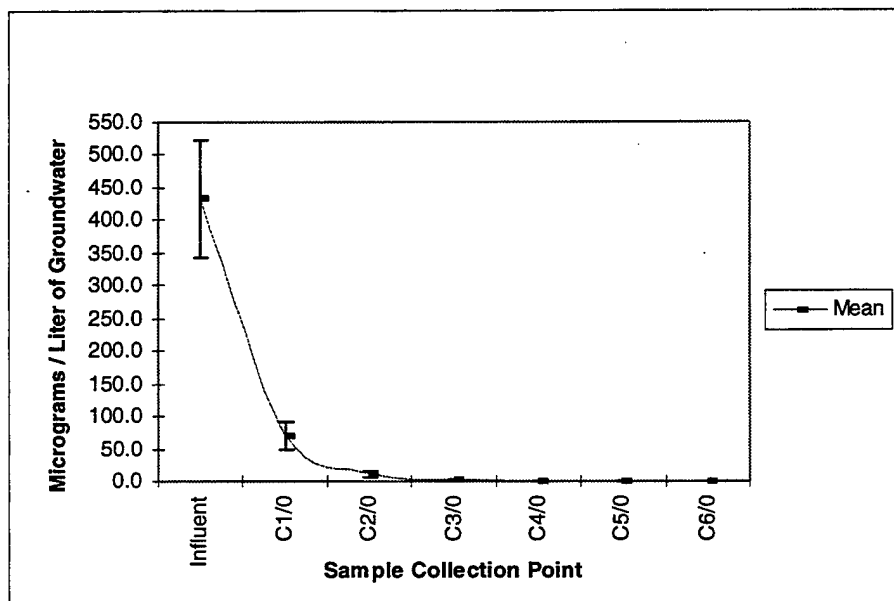

Figure 12. TNT Data Range.

	Influent	C1/0	C2/0	C3/0	C4/0	C5/0	C6/0
Number of Samples	21	21	21	21	21	21	21
Mean	34.0	8.6	1.5	0.3	0.2	0.2	0.2
Standard Deviation	5.3	1.8	0.3	0.2	0.0	0.0	0.0
Range	21.3	8.5	1.1	0.7	0.0	0.0	0.0
Minimum	22.6	5.8	1.1	0.2	0.2	0.2	0.2
Maximum	43.9	14.3	2.2	0.9	0.2	0.2	0.2

Table 27 1,3,5-Triazine (RDX).

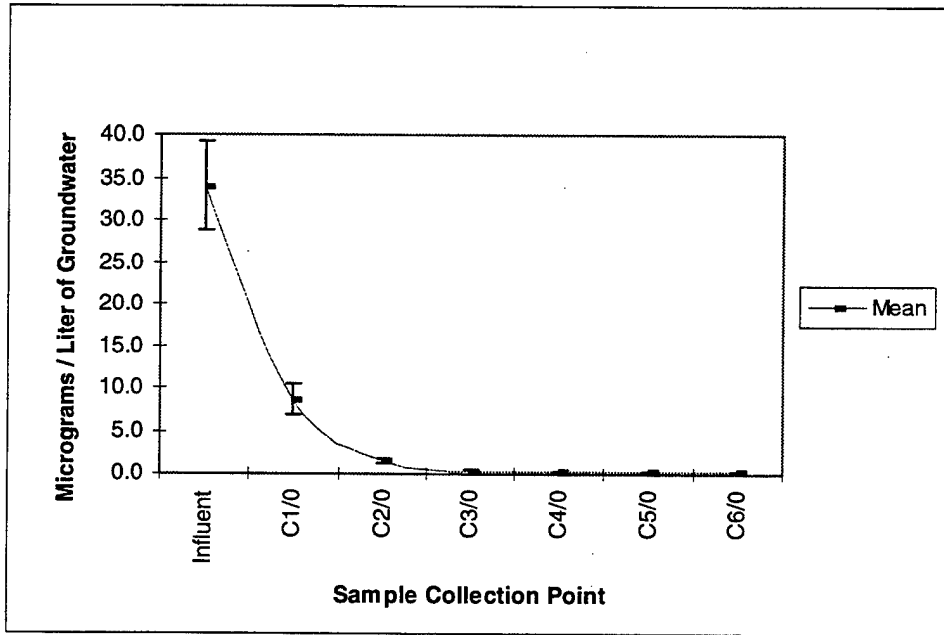

Figure 13. RDX Data Range.

	<i>Influent</i>	<i>C1/0</i>	<i>C2/0</i>	<i>C3/0</i>	<i>C4/0</i>	<i>C5/0</i>	<i>C6/0</i>
Number of Samples	21	21	21	21	21	21	21
Mean	998.1	216.8	59.4	18.0	6.0	2.0	0.7
Standard Deviation	167.3	54.1	13.0	4.2	1.9	0.8	0.3
Range	652.0	217.0	43.2	13.6	6.0	3.3	1.3
Minimum	758.0	142.0	43.1	12.0	3.5	0.9	0.3
Maximum	1410.0	359.0	86.3	25.6	9.5	4.2	1.6

Table 28. Total Nitrobodyes.

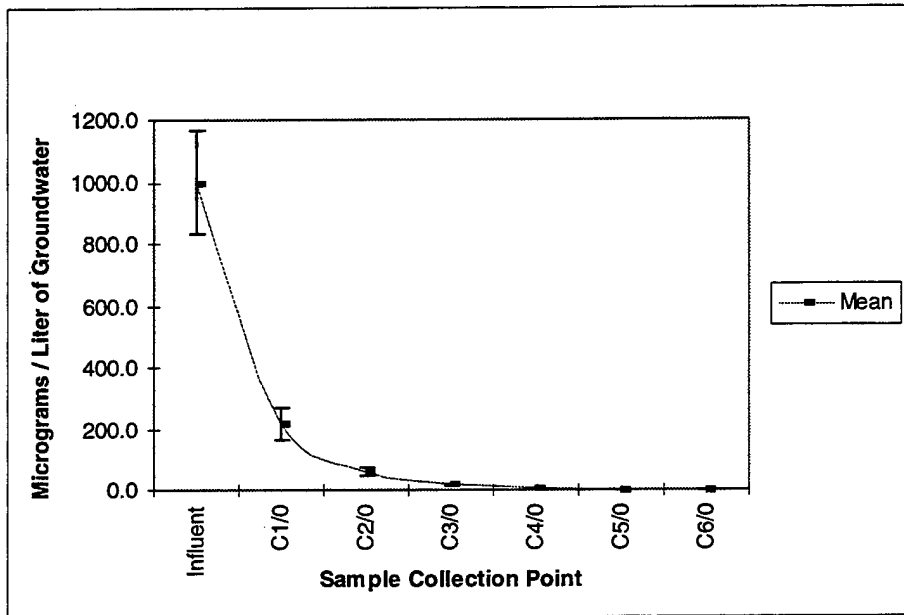

Figure 14. Total Nitrobodyes Data Range.

B. MAXIMUM FLOW RATE DEMONSTRATION

The maximum flow rate demonstration consisted of running the PGTP at a flow rate of 25 gpm, an O₃ dosage and an H₂O₂ dosage of approximately 46 mg/L and 24 mg/L of groundwater per contactor.

	Influent	C1/0	C2/0	C3/0	C4/0	C5/0	C6/0
Number of Samples	20	20	20	20	20	20	20
Mean	310.6	69.4	15.3	3.2	0.6	0.1	0.1
Standard Deviation	65.8	13.0	2.9	0.7	0.2	0.1	0.0
Range	248.0	54.4	10.2	2.6	0.8	0.2	0.0
Minimum	198.0	45.6	11.4	2.1	0.1	0.1	0.1
Maximum	446.0	100.0	21.6	4.7	0.9	0.3	0.1

Table 29. 2,4,6-Trinitrotoluene.

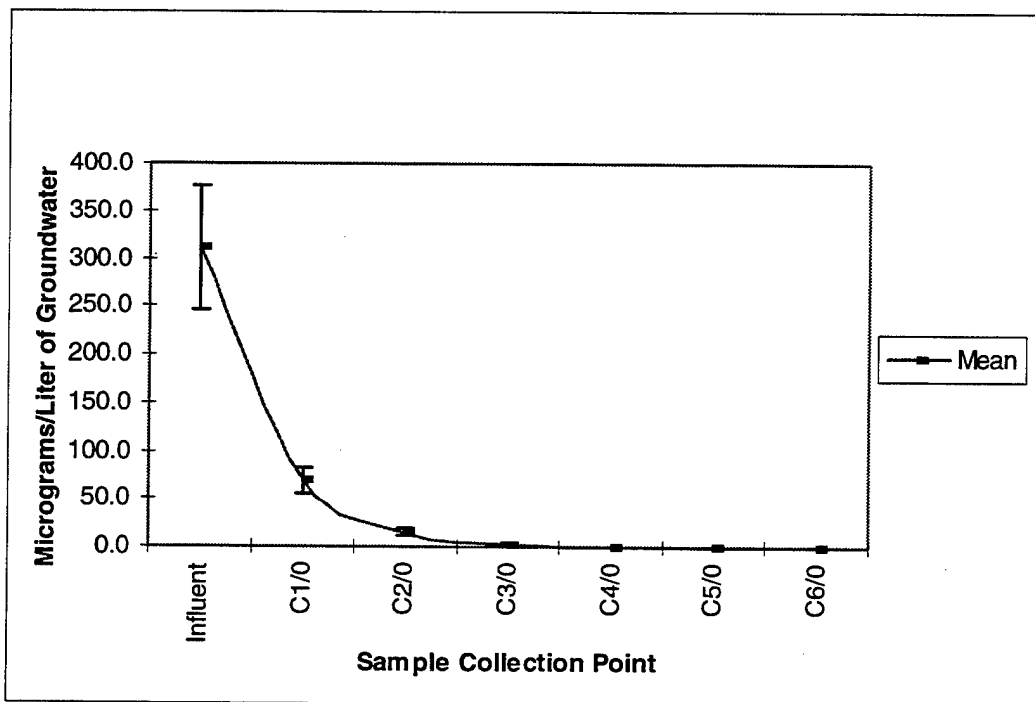

Figure 15. TNT Data Range.

	Influent	C1/0	C2/0	C3/0	C4/0	C5/0	C6/0
Number of Samples	20	20	20	20	20	20	20
Mean	23.4	8.0	2.3	0.6	0.2	0.2	0.2
Standard Deviation	4.6	1.7	0.5	0.2	0.0	0.0	0.0
Range	18.1	6.4	1.8	0.6	0.1	0.0	0.0
Minimum	18.0	5.0	1.6	0.3	0.2	0.2	0.2
Maximum	36.1	11.4	3.4	0.9	0.3	0.2	0.2

Table 30. 1,3,5-Triazine (RDX).

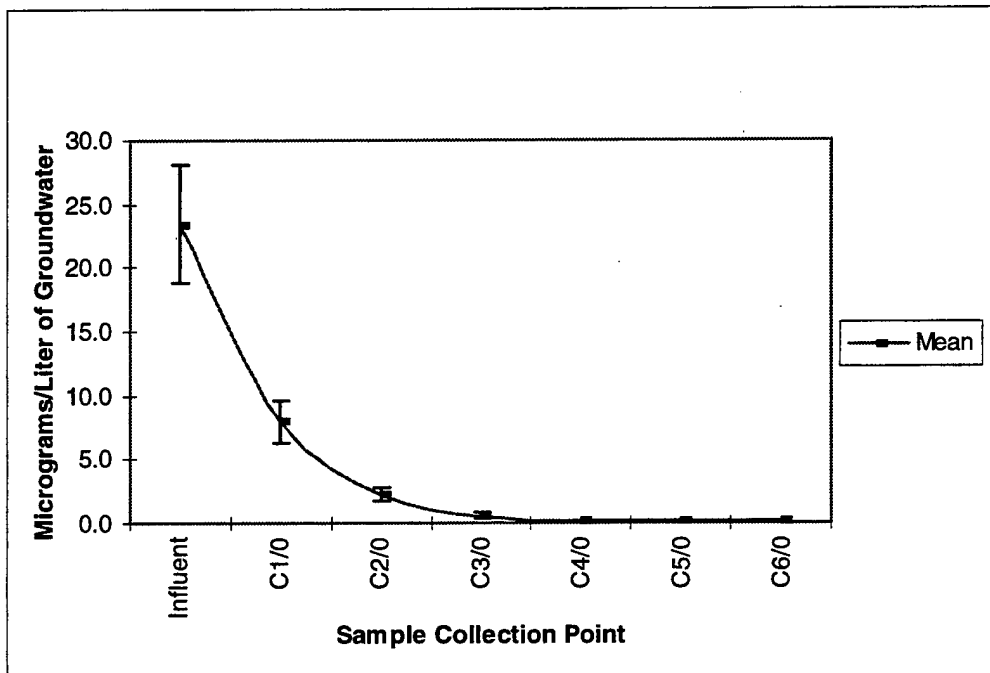

Figure 16. RDX Data Range.

	Influent	C1/0	C2/0	C3/0	C4/0	C5/0	C6/0
Number of Samples	20	20	20	20	20	20	20
Mean	754.5	236.0	90.0	33.5	13.5	5.8	2.3
Standard Deviation	136.6	33.0	13.4	6.4	2.5	1.4	0.5
Range	495.0	134.0	45.9	28.3	8.0	5.5	2.4
Minimum	535.0	184.0	73.1	22.4	9.3	3.5	1.4
Maximum	1030.0	318.0	119.0	50.7	17.3	9.0	3.8

Table 31. Total Nitrobodies.

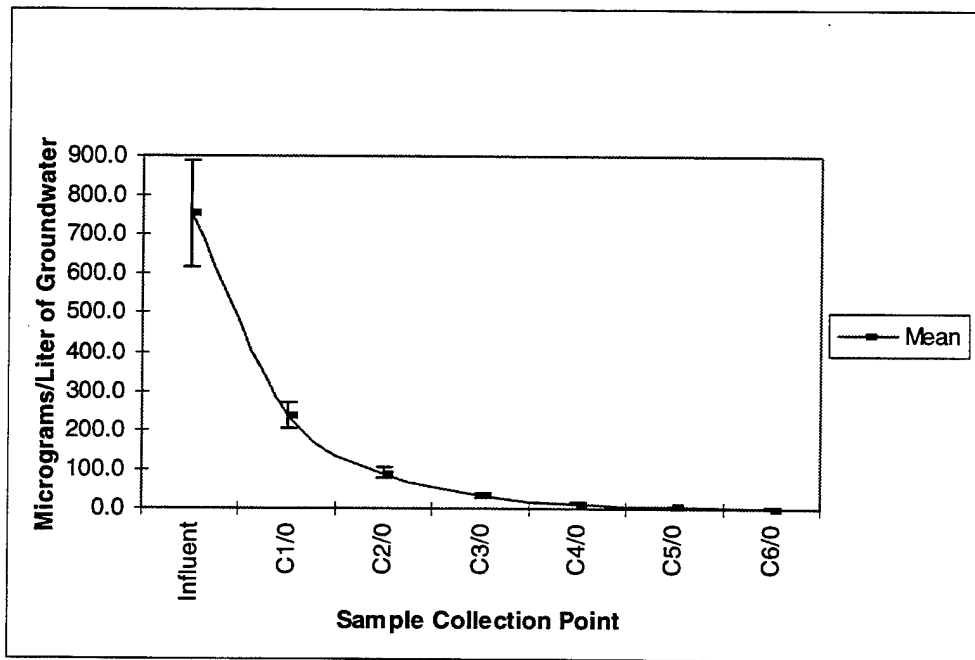

Figure 17. Total Nitrobodies Data Range.

APPENDIX C. ANALYSIS RESULTS

This appendix provides the remaining results from the effluent analysis for all explosive contaminants and contactor analysis for TNT, RDX, and Total Nitrobenzenes.

A. 13 GPM FLOW RATE DEMONSTRATION

1. Effluent Analysis

The treatment goals for all contaminants except TNB, TNT, RDX, and Total Nitrobenzenes are from NPDES and are measured in $\mu\text{g} / \text{L}$ of groundwater.

Explosive Contaminant	C6/0 Max Level	Treatment Goal	Meets Goal?
TNB	1.6	2.0	√
TNT	0.1 (BQL)	2.0	√
RDX	0.2 (BQL)	2.0	√
1,3-DNB	0.4 (BQL)	5.0	√
2,4-DNT	0.4 (BQL)	100.0	√
2-amino-4,6-DNT	0.4 (BQL)	40.0	√
2-DNT	0.7 (BQL)	40.0	√
3-DNT	0.7 (BQL)	40.0	√
4-amino-2,6-DNT	0.7 (BQL)	40.0	√
4-DNT	0.7 (BQL)	100.0	√
HMX	0.7 (BQL)	40.0	√
Nitrobenzene	0.7 (BQL)	30.0	√
Methyl-2,4,6-TNPH	0.7 (BQL)	100.0	√
Total Nitrobenzenes	1.6	30.0	√
Nitrate as Nitrogen	5.6	100.0	√

Table 32. Effluent Analysis Results for 13 GPM Flow Rate Demonstration.

2. Contactor Analysis

The following figures represent the results of the contactor analysis for TNT, RDX, and Total Nitrobenzenes. The regression curves for all three indicate exponential decay rates of the contaminants during contactor treatment.

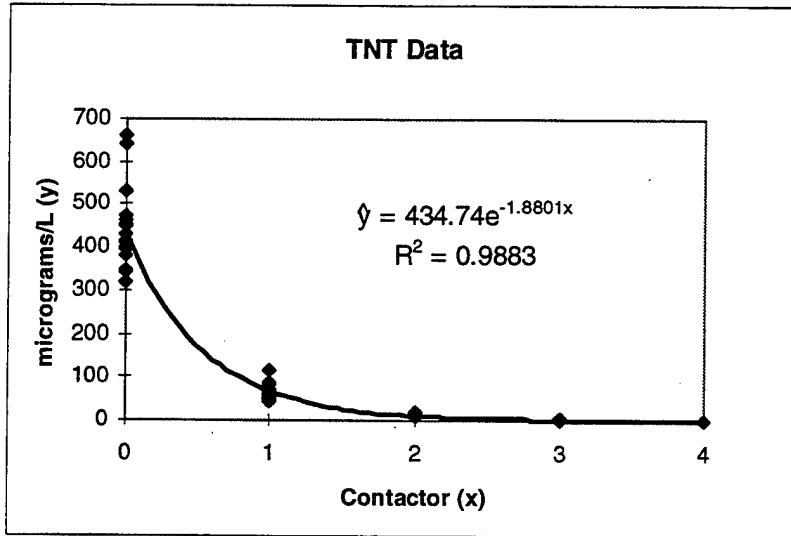

Figure 18. TNT Regression Analysis.

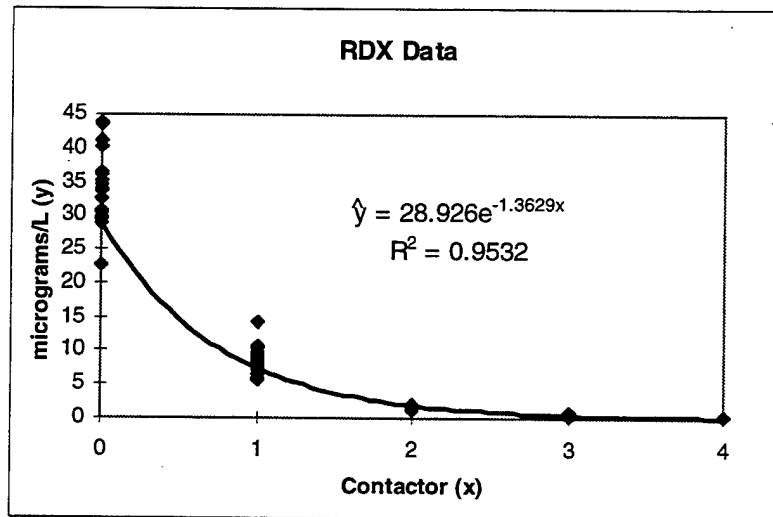

Figure 19. RDX Regression Analysis.

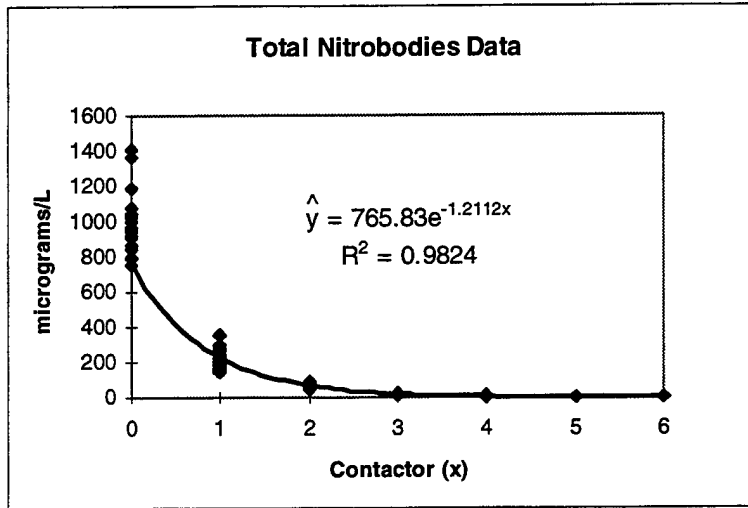

Figure 20. Total Nitrobodyes Regression Analysis.

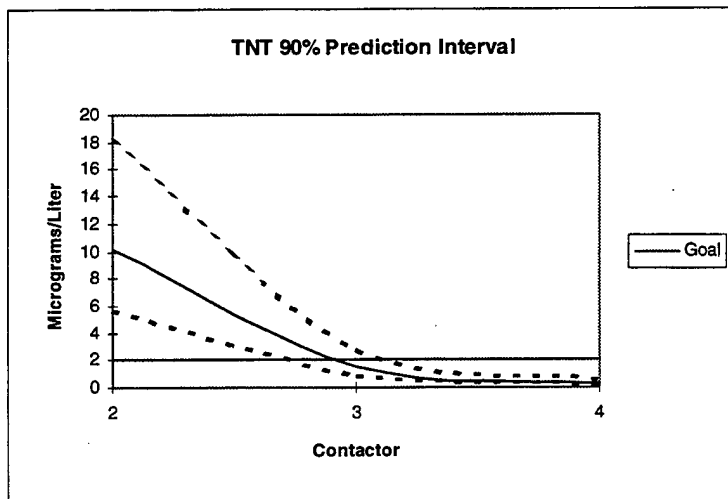

Figure 21. TNT Prediction Interval.

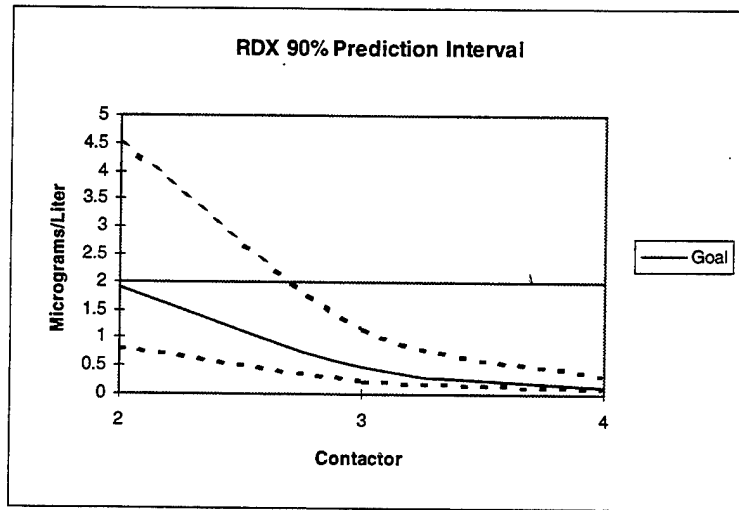

Figure 22. RDX Prediction Interval.

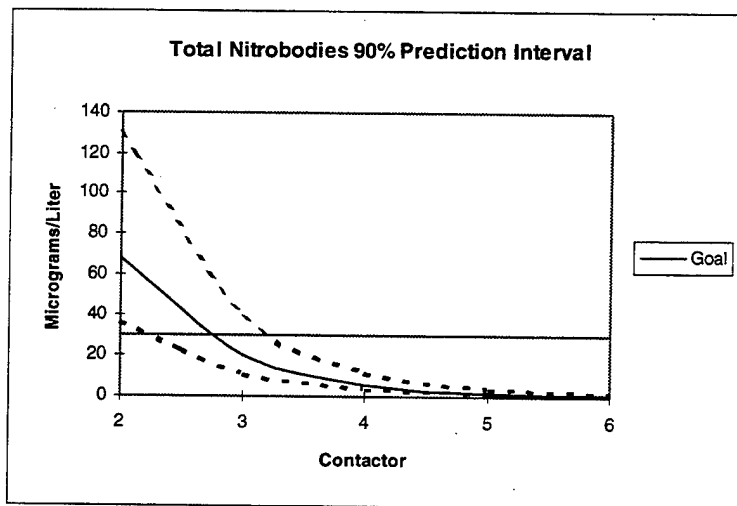

Figure 23. Total Nitrobenzenes Prediction Interval.

B. MAXIMUM FLOW RATE DEMONSTRATION

1. Effluent Analysis

Explosive Contaminant	C6/0 Max Level	Treatment Goal	Meets Goal?
TNB	3.8	2.0	NO
TNT	0.1 (BQL)	2.0	√
RDX	0.2 (BQL)	2.0	√
1,3-DNB	0.4 (BQL)	5.0	√
2,4-DNT	0.4 (BQL)	100.0	√
2-amino-4,6-DNT	0.4 (BQL)	40.0	√
2-DNT	0.7 (BQL)	40.0	√
3-DNT	0.7 (BQL)	40.0	√
4-amino-2,6-DNT	0.7 (BQL)	40.0	√
4-DNT	0.7 (BQL)	100.0	√
HMX	0.7 (BQL)	40.0	√
Nitrobenzene	0.7 (BQL)	30.0	√
Methyl-2,4,6-TNPH	0.7 (BQL)	100.0	√
Total Nitro bodies	3.8	30.0	√
Nitrate as Nitrogen	2.5	100.0	√

Table 33. Effluent Analysis Results for Maximum Flow Rate Demonstration.

2. Contactor Analysis

The following figures represent the additional results of the contactor analysis.

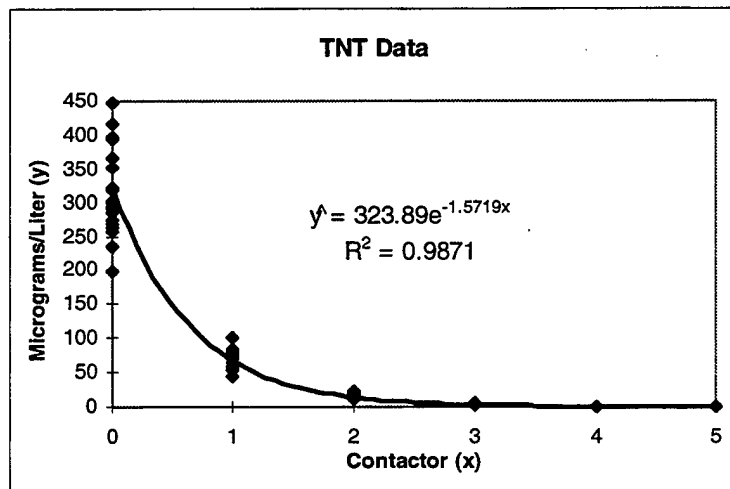

Figure 24. TNT Regression Analysis.

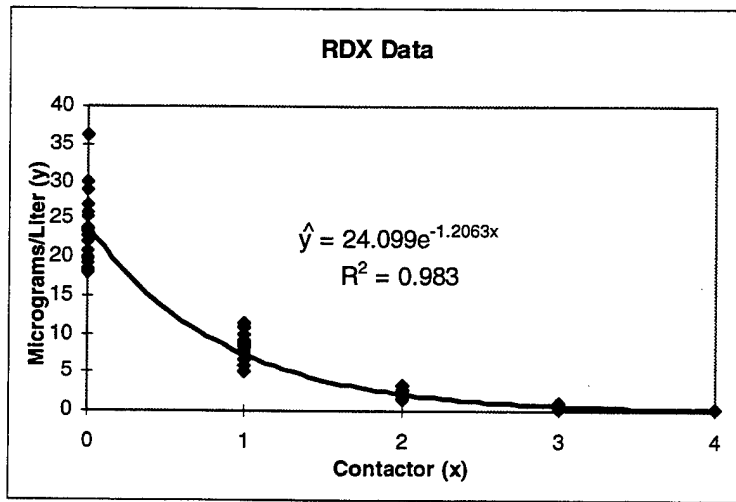

Figure 25. RDX Regression Analysis.

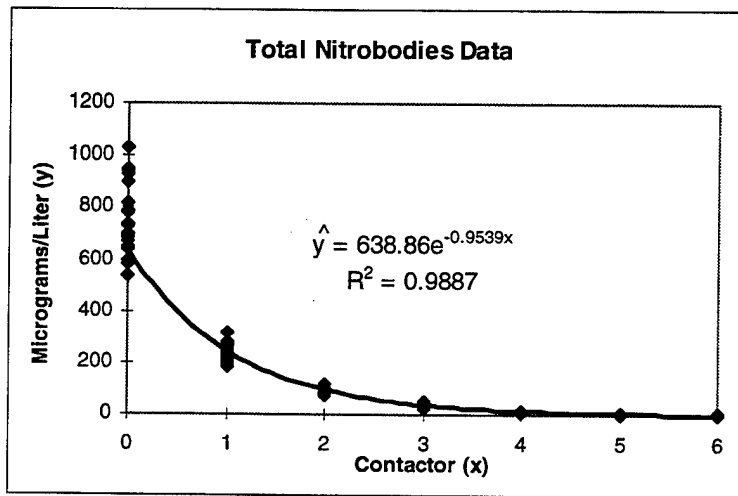

Figure 26. Total Nitrobenzenes Regression Analysis.

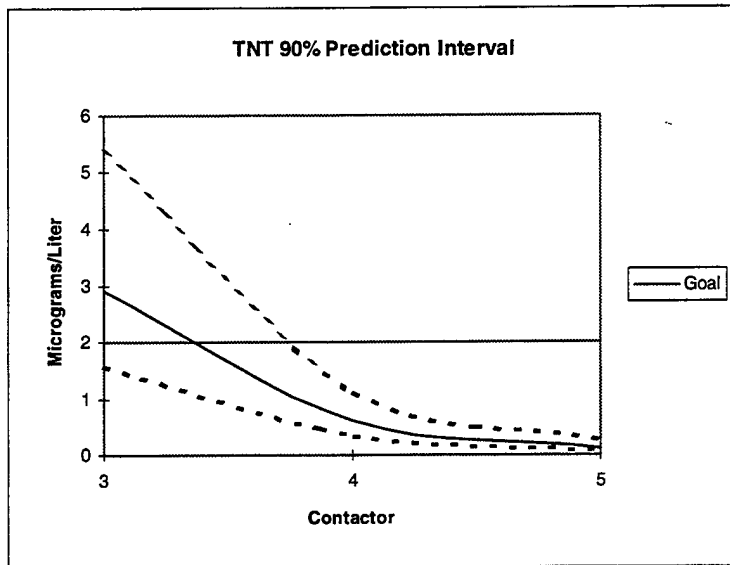

Figure 27. TNT Prediction Interval.

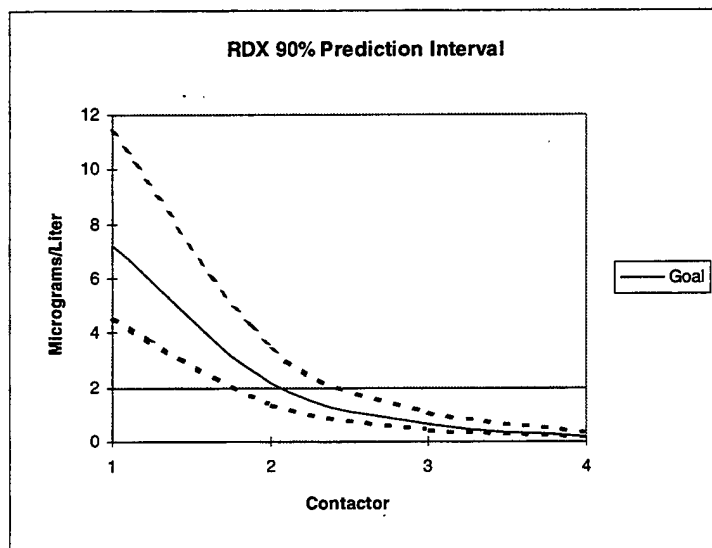

Figure 28. RDX Prediction Interval.

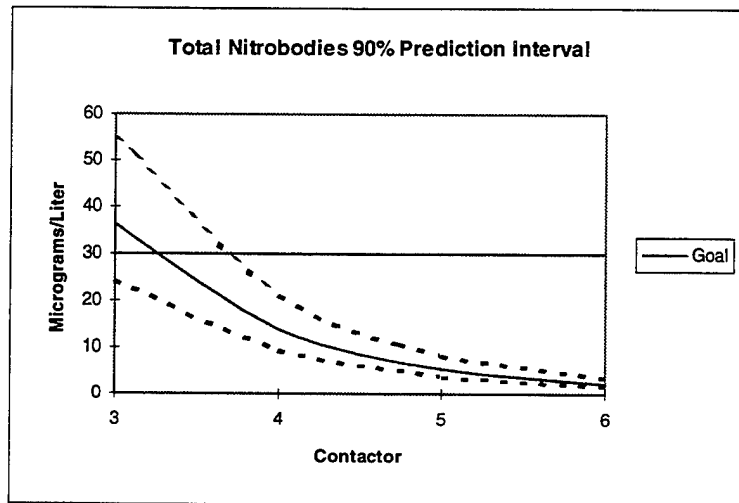

Figure 29. Total Nitrobodies Prediction Interval.

APPENDIX D. GAC AND UV/OX COST DATA

This Appendix contains the complete capital and annual operating cost data for the two GAC methods and the UV/OX method. The cost data for all methods are in FY 95 dollars. Tables 34 and 35 are the complete cost data for the two GAC methods.

PRIMARY OPERATING DATA			
Operations			
Days	250 days/yr	hr/yr	hr/shift
Shifts	1 shift/day	2,000	8
No. of Operators	0.2 operators/shift		
Pink Water			
Flowrate	20 gpm		
	9,600 gpd		
	2,400,000 gpy		
COST DATA			
Capital Costs		Utilities	
Contingency	3 % Fixed Capital	Electricity	0.1 \$/kW-hr
Working Capital	20 % Fixed Capital	Other	10 % Electric
Direct Expenses		Indirect Expenses	
Operator Labor	10 \$/hr	Supervision	25 % Labor and Maint
Maintenance	1.5 % Fixed Capital	Overhead	30 % Labor and Maint
Supplies	10 % Maintenance		
Materials	1.5 % Fixed Capital		
Lab Charges	10 % Labor		
Process Specific Calculations		Attrition Rate	
Explosive Adsorb	30 wt %	Cost of Carbon	85 %
Explosive Adsorbed	4,000 lb/yr	Regeneration and Shipping	1 \$/lb
Carbon Required	13,333 lb		0.85 \$/lb
CAPITAL COSTS		OPERATING COSTS	
Fixed Capital (Includes installation)	130,000	Raw Materials (Including carbon)	3,950
Contingency (3% Fixed Capital)	3,900	Utilities (Estimate)	2,000
Working Capital (20% Fixed Capital)	26,000	Labor	4,000
		Maintenance (1.5% Fixed Capital)	1,950
		Lab Charges (10% Labor)	400
		Incineration and Shipping	14,733
		Supplies (10% Maintenance)	400
		Supervision (25% Labor & Maintenance)	1,488
		Overhead (30% Labor and Maintenance)	1,785
TOTAL Capital Costs:	159,900	TOTAL Operating Costs	30,706

Table 34. GAC/ Thermal Regeneration From Ref. 11.

PRIMARY OPERATING DATA				
Operations				
	Days	250 days/yr	hr/yr	hr/shift
	Shifts	1 shift/day	2,000	8
	No. of Operators	0.2 operators/shift		
Pink Water				
	Flowrate	20 gpm		
		9,600 gpd		
		2,400,000 gpy		
COST DATA				
Capital Costs			Utilities	
	Contingency	3 % Fixed Capital	Electricity	0.1 \$/kW-hr
	Working Capital	20 % Fixed Capital	Other	10 % Electric
Direct Expenses			Indirect Expenses	
	Operator Labor	10 \$/hr	Supervision	25 % Labor and Maint
	Maintenance	1.5 % Fixed Capital	Overhead	30 % Labor and Maint
	Supplies	10 % Maintenance		
	Materials	1.5 % Fixed Capital		
	Lab Charges	10 % Labor		
Process Specific Calculations			Cost of Carbon	
	Explosive Adsorb	30 wt %	Incineration and Shipping	1 \$/lb
	Explosive Adsorbed	4,000 lb/yr		1.2 \$/lb
	Carbon Required	13,333 lb		
CAPITAL COSTS		OPERATING COSTS		
Fixed Capital (Includes installation)	130,000	Raw Materials (Including carbon)	15,283	
Contingency (3% Fixed Capital)	3,900	Utilities (Estimate)	2,000	
Working Capital (20% Fixed Capital)	<u>26,000</u>	Labor	4,000	
		Maintenance (1.5% Fixed Capital)	1,950	
		Lab Charges (10% Labor)	400	
		Incineration and Shipping	20,800	
		Supplies (10% Maintenance)	400	
		Supervision (25% Labor & Maintenance)	1,488	
		Overhead (30% Labor and Maintenance)	<u>1,785</u>	
TOTAL Capital Costs:	159,900	TOTAL Operating Costs	48,106	

Table 35. GAC/ Incineration From Ref. 11.

APPENDIX E. PEROXONE COST DATA

This Appendix contains the complete capital and annual operating cost data, in FY 97 dollars, for the demonstrated *Peroxone* process. A cost estimate is provided for the 13 gpm flow rate demonstration and for the maximum (25gpm) flow rate demonstrations. Each flow rate demonstration cost is adjusted to a "standard" 20 gpm flow rate for 8 hours a day, 250 days a year, using the same scaling methods in Appendix D. The chemical and power costs used in the calculations were collected and determined by DESA's contracted on-site BDM representative. Liquid oxygen (O₂) was used for ozone generation.

The capital cost estimate for Montgomery Watson's PGTP is \$131,570. This estimate is based on equipment costs for the PGTP of \$164,462 and an estimated 80% learning curve for full scale production ($\$164,462 \times 0.80 = \$131,570$). Using the Chemical Engineering Scaling Formula in Chapter IV, Section B, the scaled capital cost estimates for the 13 gpm and maximum (25 gpm) flow rate are \$170,376 and \$115,083 respectively. Scaling of contactor diffusers is not required since the value of each diffuser is small in comparison to the chemical usage. Table 36 provides the cost data for the 13 gpm flow demonstration adjusted 20 gpm standard.

Consumable	Units	Cost (\$/unit)	Average Units/1000gallons	Gallons/Day	Cost \$/day	Cost \$/yr
Electricity	kWh	\$0.06	17.83	9,600	\$10.27	\$2,567.52
H ₂ O ₂	gal	\$4.00	0.6975	9,600	\$26.78	\$6,696.00
Liquid O ₂	ft ³	\$0.0069	1123.19	9,600	\$74.40	\$18,600.03
Carbon (GAC)	lb	\$1.11	NA	9,600	\$0.00	\$0.00
GAC Regen. and Shipping	lb	\$0.95	NA	9,600	\$0.00	\$0.00
Ozone Catalysts	catalysts	\$50.00	NA	9,600	\$1.00	\$250.00
Upsets/Restarts	no. occurrences	\$0.00	0	9,600	\$0.00	\$0.00
Down Time	minutes	\$0.00	0	9,600	\$0.00	\$0.00
Contactor Labor	minutes	\$0.248	0.0059	9,600	\$0.01	\$3.51
Ozone Generator Labor	minutes	\$0.248	0.14	9,600	\$0.33	\$83.33
Totals					\$112.80	\$28,200.39

Table 36. Peroxone (GAC MINUS) Annual Operating Costs After Ref. 6.

The cost for Granular Activated Carbon (GAC) is based on an estimate of 500 pounds of explosives absorbed per year. Both GAC cost estimates have an estimate of 4000 pounds of explosives absorbed per year. Since the only contaminant requiring treatment is TNB, a worst case of 500 pounds is used. According to NDCEE, GAC absorbs 30% of the explosives by weight [Ref. 11]. Therefore, at 500 pounds of explosives, approximately 1,667 pounds of GAC is required per year. For the demonstration, 1,000 pounds of GAC was on site. The cost per pound of GAC from NDCEE's report at \$1.00 per pound is adjusted for inflation at 5.25% per year [Ref. 11]. In the maximum flow rate estimate, thermal regeneration is the assumed method for "explosive-laden" GAC treatment [Ref. 11]. The cost of thermal regeneration and shipping from NDCEE's report is also adjusted for inflation. Table 37 provides the operating cost for the maximum (25 gpm) flow rate adjusted to the 20 gpm standard.

Consumable	Units	Cost (\$/unit)	Average Units/1000gallons	Gallons/Day	Cost \$/day	Cost \$/yr
Electricity	kWh	\$0.06	17.83	9,600	\$10.27	\$2,567.52
H ₂ O ₂	gal	\$4.00	0.425	9,600	\$16.32	\$4,080.00
Liquid O ₂	ft ³	\$0.0069	445.36	9,600	\$29.50	\$7,375.16
Carbon (GAC)	lb	\$1.11	NA	9,600	\$7.40	\$1,850.00
GAC Regen. and Shipping	lb	\$0.95	NA	9,600	\$6.33	\$1,582.50
Ozone Catalysts	catalysts	\$50.00	NA	9,600	\$1.00	\$250.00
Upsets/Restarts	no. occurrences	\$0.00	0	9,600	\$0.00	\$0.00
Down Time	minutes	\$0.00	0	9,600	\$0.00	\$0.00
Contact Labor	minutes	\$0.248	0.0059	9,600	\$0.01	\$3.51
Ozone Generator Labor	minutes	\$0.248	0.14	9,600	\$0.33	\$83.33
Totals					\$71.17	\$17,792.02

Table 37. Peroxone (GAC PLUS) Annual Operating Costs After Ref. 6.

LIST OF REFERENCES

1. TRW Space & Technology Division, "Peroxone Demonstration Program Cornhusker Army Ammunition Plant Grand Island, Nebraska", One Space Park, Redondo Beach, California, May 1996.
2. United States Army Environmental Center, Peroxone Groundwater Treatment System Demonstration, Statement of Work for Subtask 03-87/100, Contract Number MDA970-89-C-0019, CDRL A003, May 1995.
3. US Army Corps of Engineers Waterways Experiment Station (WES) Homepage, <http://www.wes.army.mil/FY94/el.html>
4. Environmental Security Technology Certification Program (ESTCP) FY 95 Programs, "Individual Program Summaries", http://www.osd.mil/ens/ESTCP_ProjectSheets.html#Peroxone.
5. Gramith, J.T., US Environmental Protection Agency (USEPA), "Overview of Metropolitan's Ozone/Peroxone Demonstration Project", Metropolitan Water District of Southern California Water Quality Division, Los Angeles, California, 1989.
6. United States Army Environmental Center (USAEC), "Evaluation of Ultraviolet Oxidation (UV/OX) Methods for the Remediation of Explosives Contaminated Groundwater: Final Report", Weston, West Chester, Pennsylvania, June 1995.
7. Montgomery Watson, "Cornhusker Army Ammunition Plant Peroxone Groundwater Treatment Project: Experimental Plan", Salt Lake City, Utah, May 1996.
8. Defense Evaluation Support Agency (DESA), "Peroxone Groundwater Treatment of Explosive Contaminants Brief to United States Army Environmental Center (USAEC)", Unpublished, Kirtland AFB, Albuquerque, New Mexico, June 1996.
9. State of Nebraska Department of Environmental Quality, "Wastewater Discharge Criteria from the Peroxone Pilot System at the Cornhusker Army Ammunition Plant", Lincoln, Nebraska, August 1995.
10. Hamilton, L.C., "Regression with Graphics: A Second Course in Applied Statistics", Duxbury Press, 1992.
11. National Defense Center for Environmental Excellence (NDCEE), "Pink Water Treatment Options", Concurrent Technologies Corporation, Johnstown, Pennsylvania, May 1995.

12. Lavine, I., Zimmerman, O. T., "Chemical Engineering Costs", Industrial Research Service, Dover, New Hampshire, 1950.
13. Prager, J., "Applied Microeconomics: An Intermediate Text", Richard D. Irwin, INC., 1993.

INITIAL DISTRIBUTION LIST

1. Defense Technical Information Center 2
8725 John J. Kingman Rd., STE 0944
Ft. Belvoir, Virginia 22060-6218
2. Dudley Knox Library 2
Naval Postgraduate School
411 Dyer Rd.
Monterey, California 93943-5101
3. Professor Lyn Whitaker 2
Code OR/Wh
Naval Postgraduate School
Monterey, California 93943-5002
4. Lynda K Liptak 2
2700 Clark Carr Loop SE
Building A
Albuquerque, New Mexico 87106
5. LTC Charles H. Shaw 2
Code OR/Sc
Naval Postgraduate School
Monterey, California 93943-5002
6. CPT Michael V. McCrea 2
128 Mill Point Dr.
Hampton, Virginia 23669
7. Director, TRAC 1
ATTN: ATRC - FA
Ft. Leavenworth, Kansas 66027
8. William J. Walker 1
6471 S. Sheridan
Tacoma, Washington 98408
9. Director, US Army TRADOC Analysis Center - Monterey 1
ATTN: ATRC-RDM (LTC Wood)
Monterey, California 93943