

REPORT DOCUMENTATION PAGE

Form Approved OMB No. 0704-0188

Public reporting burden for this collection of information is estimated to average 1 hour per response, including the time for reviewing instructions, searching existing data sources, gathering and maintaining the data needed, and completing and reviewing the collection of information. Send comments regarding this burden estimate or any other aspect of this collection of information, including suggestions for reducing this burden to Washington Headquarters Services, Directorate for Information Operations and Reports, 1215 Jefferson Davis Highway, Suite 1204, Arlington, VA 22202-4302, and to the Office of Management and Budget, Paperwork Reduction Project (0704-0188), Washington, DC 20503.

| | | | | |
|--|--|---|---|--|
| 1. AGENCY USE ONLY (Leave blank) | | 2. REPORT DATE 22 July 1997 | 3. REPORT TYPE AND DATES COVERED Final Report | |
| 4. TITLE AND SUBTITLE The Study Of The Gravity Effect On The 129 Ag Y-Resonance | | | 5. FUNDING NUMBERS F6170896W0217 | |
| 6. AUTHOR(S) Dr. Andrey Davydov | | | | |
| 7. PERFORMING ORGANIZATION NAME(S) AND ADDRESS(ES) Institute of Theoretical and Experimental Physics Bolshaya Cheremushkinskaya Str. 25 Moscow 117259 Russia | | | 8. PERFORMING ORGANIZATION REPORT NUMBER N/A | |
| 9. SPONSORING/MONITORING AGENCY NAME(S) AND ADDRESS(ES) EOARD PSC 802 BOX 14 FPO 09499-0200 | | | 10. SPONSORING/MONITORING AGENCY REPORT NUMBER SPC 96-4037 | |
| 11. SUPPLEMENTARY NOTES | | | | |
| 12a. DISTRIBUTION/AVAILABILITY STATEMENT Approved for public release; distribution is unlimited. | | | 12b. DISTRIBUTION CODE A | |
| 13. ABSTRACT (Maximum 200 words) This report results from a contract tasking Institute of Theoretical and Experimental Physics as follows: The contractor will obtain data about broadening factor of ^{109}Ag 88 keV Mössbauer gamma-line in the silver single crystal. | | | | |
| 14. SUBJECT TERMS Lasers, Physics | | | 15. NUMBER OF PAGES 7 | |
| | | | 16. PRICE CODE N/A | |
| 17. SECURITY CLASSIFICATION OF REPORT UNCLASSIFIED | 18. SECURITY CLASSIFICATION OF THIS PAGE UNCLASSIFIED | 19. SECURITY CLASSIFICATION OF ABSTRACT UNCLASSIFIED | 20. LIMITATION OF ABSTRACT UL | |

19970909 141

SPC 96 - 4037

REVISED

REPORT

on the scientific research

STUDY OF THE GRAVITY EFFECT ON ^{109}Ag GAMMA-RESONANCE

Work leader: D-r A.V.Davydov, ITEP, Moscow, Russia.

E-mail: davydov@vxitep.itep.ru

Contract: F 61708-96-W0217

The aim of this work is to obtain the data about broadening factor of ^{109}Ag 88 keV Mössbauer gamma-line in the silver single crystal. The method consists in the measurements of temperature dependencies of 88 keV gamma-ray yields from the single crystal source in the horizontal and vertical directions. If the broadening factor is really small, as state the authors of [1-4], then at liquid helium temperature the excess absorption must appear in the silver source connected with Mössbauer effect. The expected relative value of this excess is about 0.0005 for horizontal direction if gamma-line is 30-fold broadened [1], and it is about 7 times lower for vertical direction, because the gravitational red shift ("blue" shift in our case) restricts the effective length of resonant gamma-ray absorption in this direction by $\sim 30\text{mcm}$. The additional effect to be studied is that of outer magnetic field direction influence on the Mössbauer absorption probability. To observe this effect the pair of Helmholtz rings is mounted coaxially with the cryostat. Switching these coils on one compensates the vertical component of Earth's magnetic field and horizontal gamma-beam becomes parallel to the remaining horizontal component. In this case the resonant absorption probability is maximal [5] and exceeds the value of this probability for normal condition by 50 %. In the experiment we have to measure the ratios of gamma-line intensities for silver source (^{109}Ag , 88 keV) and additional control source (^{241}Am , 59.54 keV) at three temperatures (room, 77 K and 4.2 K) for two directions of outer magnetic field in each case. To be sure that switching on and off the Helmholtz rings leads really to the expected direction of the magnetic field in the site of the gamma-sources one has to remove all ferromagnetic parts of experimental set-up and change them by details made of nonmagnetic materials. This was done, as we have written in our interim report [6]. However at the time of writing of [6] the problem was unresolved connected with revealed ferromagnetism of our control gamma-source made of ^{57}Co in silver matrix. This unexpected characteristic of the source did not permit to place it near the silver source because strong magnetic field of ferromagnetic object could distort the needed magnetic field picture in this site. So we was forced to fabricate a new control gamma-sources. It was decided to make it of ^{241}Am in the gamma-spectrum of which the gamma-line dominated with energy of 59.54 keV. To make the source with acceptable homogeneity of ^{241}Am distribution over its area the concentric rings of chromatographic paper were cut out which areas were the multiples of the

central small disc area. Then each ring (and the central disc also) were impregnated by 0.5N nitroacidic solution of ^{241}Am in the amounts proportional to the ring (disc) area and dried. After that the rings (and central disc) were glued concentrically on the inner bottom of the cup made of aluminium foil by the cryostable glue VT-200 forming the disc of ~ 25 mm in diameter. Then the paper disc was covered by Al foil circle using the same glue and, after turning down the walls of aluminium cup to the disc plane, the second Al circle was glued on this sandwich. After the glue hardening the gamma-source was tested on tightness by multiple immersion in liquid nitrogen with following warming up and by placing into vacuum chamber. The cleaning rag of the source by gauze shown the absence of radioactivity on its surface. Now our set-up looks as it shown on Fig. 1. Silver gamma-source is mounted in the helium (nitrogen) volume and separated from vacuum part of the cryostat by copper foil. The ^{241}Am gamma-source is placed at the other side of this foil inside of vacuum volume and is pressed to the foil by berillium plate to prevent the excess sugging of the foil at the pumping of the cryostat. In autumn 1996 we have measured the apparatus gamma-line forms for both gamma-sources separately. This was necessary to do for the following comparison of the sum of two independently measured spectra with gamma-spectrum obtained under condition when both gamma-sources were on their place in the cryostat. This comparison would permit to determine the contribution of pulse pile-up processes. Then we began the main measurements. We had to choice between two versions of measurement regime:

a) To work with two detectors simultaneously. In this case the detector of horizontal gamma-beam would be placed at a distance of at least 45 cm from gamma-sources because the diameters of two dewars with Ge(Li)-detectors did not permit to bring them together closer. This led to the low counting rate of this detector. From the other side this mode of measurement would give a possibility to obtain the results from both detectors simultaneously.

b) To work at first with detector of horizontal gamma-beam only, placing it at the distance of 25 cm from gamma-sources, and then to perform the measurements with detector of vertical gamma-beam. This version would give a 3.2-fold gain in the duration of a measurement with horizontal beam detector and total gain of 2.1 times, because the vertical beam detector permits to obtain large counting rate and measurement with this detector only would require no more than 0.5 of the time required for the horizontal beam detector. However in this case the simultaneity of both measurements would be lost.

As we felt the time shortage, we have chosen the second version and performed the measurements at room and liquid nitrogen temperatures in horizontal direction. However we couldn't perform the measurements at liquid helium temperature because the ITEP Cryogenic laboratory had no possibility to fabricate liquid helium until now. This is connected with shortage of finance to pay for electric power. Cryogenic laboratory couldn't fabricate liquid nitrogen necessary for helium liquation simultaneously with work of ITEP proton-synchrotron. Our direction gave the priority

to the accelerator. So we was forced to move the measurements at liquid helium temperature to autumn 1997.

The results of measurements at room and liquid nitrogen temperatures are the following (horizontal gamma-beam): At room temperature the values of the gamma-ray intensity ratio

$$R = N(^{109}\text{Ag}, 88 \text{ keV})/N(^{241}\text{Am}, 59.54 \text{ keV}),$$

measured under condition of normal direction of Earth's magnetic field (R1) and in the case when only horizontal component of this field influences upon gamma-sources and the axis of horizontal gamma-beam coincides with direction of magnetic field (R2) are equal to:

$$R1 = 0.70216 \pm 0.00013$$

$$R2 = 0.70225 \pm 0.00011$$

At liquid nitrogen temperature these ratios are the following:

$$R1 = 0.69761 \pm 0.00013$$

$$R2 = 0.69753 \pm 0.00014$$

It is seen that change of magnetic field direction does not influence on value of R at both temperatures, as one would expect, within the limits of experimental errors. Note that these errors are root-mean-squared over the real straggling of experimental values of Rs. The decrease of R after transition to 77 K which could be caused by possible Mössbauer absorption is ~ 50 times smaller than that at 4.2 K. This corresponds to $\sim 10^{-5}$ if gamma-line is 30-fold broadened. Switching of magnetic field direction could lead to the difference of R1 and R2 which would be equal to 60 % of 1×10^{-5} . This value can not be observed at our level of experimental errors. However it is funny that formal difference of R1 and R2 measured at 77 K is just of this scale and of proper sign.

During these measurements the long time observations were performing of the cryostat inner part deformations by means of an optical system including the theodolite. On the Fig. 2 the results of these observations are shown corresponding to 3 axes: vertical, horizontal in the direction to the detector and perpendicular to both them. It is seen that after cooling to 77 K the inner volume of the cryostat displaced upward as a result of shortening of stainless steel tube through which the cryogenic liquid is conveyed. Some lesser initial displacements are seen in the horizontal plane. For us the most important are the values of the displacements along the axes of horizontal and vertical gamma beams because they may lead to the changes of the measured ratios R of two gamma-line intensities at the transition from 300 to 77 K and at the following transition from 77 to 4.2 K. These changes are connected with some difference between the distances r_1 and r_2 of two gamma-sources from the detector. Ratio R is proportional to $(r_1/r_2)^2$. If $\Delta r = r_1 - r_2 = 2 \text{ mm}$

then at $r_1 = 250$ mm the decrease of r_1 and r_2 equal to 1 mm would lead to the relative change of R about 6.5×10^{-6} . This change is sufficiently smaller than the level of our statistical accuracy but must be taken into account. Note that we expect the ~ 10 -fold lesser displacements at the transition from 77 to 4.2 K.

It is interesting that the displacements of inner part of the cryostat change with time despite the temperature and other experimental conditions are stable. This behavior of cooled mechanical parts of the cryostat are probably deserved of special study.

Conclusions.

1. The experimental device is completely in operating state.
2. New control gamma-source was made of ^{241}Am instead of previous source of ^{57}Co in silver foil. This gamma-source is mounted inside of cryostat and was used in the performed measurements.
3. The measurements was made at room and liquid nitrogen temperatures. They shown that it is quite possible to achieve the relative accuracy of measured gamma-ray intensity ratios, R , about 10^{-4} by real straggling. The time of measurement is about 12-15 days for horizontal gamma-beam detector and about twice less for vertical beam detector.
4. The cryostat deformations are sufficiently small and can not influence on the measured values of R s beyond the bounds of relative experimental errors of order 1×10^{-4} .
5. It was checked by the measurements at room and liquid nitrogen temperatures that switching of magnetic coils compensating the vertical component of Earth's magnetic field does not influence on the performance of the gamma detecting equipment.
6. The measured change in the value of $N(^{109}\text{Ag})/N(^{241}\text{Am})$ ratio at the transition from room temperature to 77 K is well agree with its calculation based on the known data about silver compression in the cooling process.

Therefore the study is not finished at present, but by reasons which are independent on our efforts. The situation may be considered as the force majeure one. We had no possibility neither to receive liquid helium from ITEP Cryogenic laboratory nor to buy it in other organization because ITEP has no money to pay for any version of acquisition. We hope that in autumn 1997 our direction will find the way to help us.

/VII-1997

Work leader

 A.V. Davydov

References.

1. W.Wildner, U.Gonser. *J. de Physique, Colloque C2, Suppl. au n° 3, Tome 40, 1979, p. C2-47 - C2-48.*
2. R.D.Taylor, G.R.Hoy. *SPIE, 1988, v. 875, p.126-133.*
3. G.R.Hoy, R.D.Taylor. *J. Quant. Spectrosc. Radiat. Transfer, 1988, v. 40, N 6, p. 763-771.*
4. S.Rezaie-Serej, G.R.Hoy, R.D.Taylor. *Laser Physics, 1995, v. 5, N 2, p. 240-257.*
5. V.G.Alpatov, Yu.D.Bayukov, A.V.Davydov et al., *Hyperfine Interactions, 1997, v. 107, p. 231-246.*
6. A.V.Davydov. *Interim report for EOARD on the scientific research "Study of the gravity effect on the Ag-109 gamma-resonance". 25/IX-1996.*

Subscripts to the figures.

Fig. 1. A. Scetch of the experimental set-up. Side view.

1. Helium volume.
2. Ge(Li)-detectors.
3. Heat screen.
4. Helmholtz rings.
5. Thin windows for gamma-beams.
6. Cryostat body.
7. One of the glass windows to observe the inner deformations.
8. Mirror (part of optical system to observe the deformations).
9. Light source.
10. Support.
11. Teflon restricter of deformation.
12. Spiral tube to cool the heat screen by outgoing vapors of cryogenic liquids.

B. Scheme of gamma-source mounting.

1. Body of helium volume.
2. Front wall of helium volume inclined at angle 45° relative the horizon.
3. Silver single crystal gamma-source.
4. Copper foil.
5. ^{241}Am control gamma-source.
6. Berillium plate.
7. Al foil.
8. Outer mounting ring (soldered-in).
9. Inner mounting ring.

Fig. 2. Results of the long time observations of the cryostat inner part deformations.

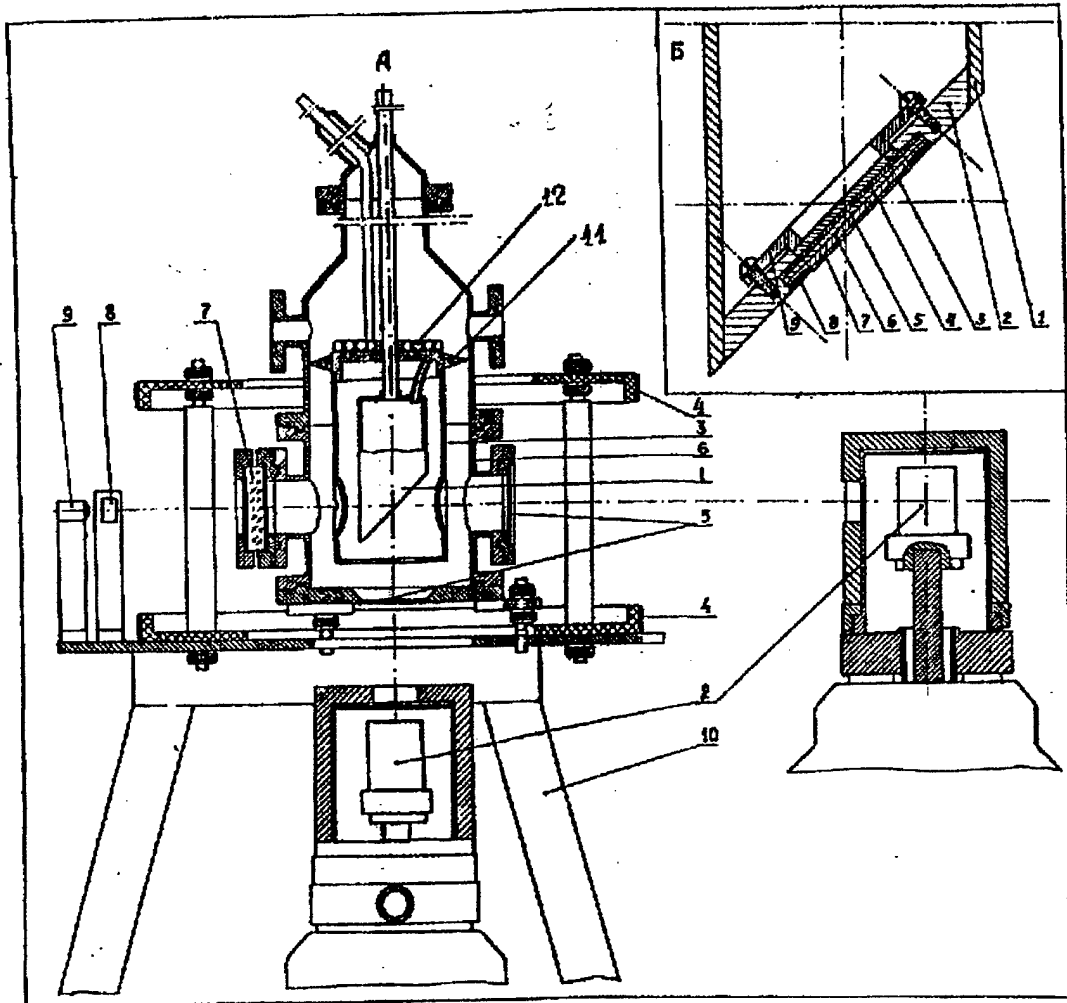
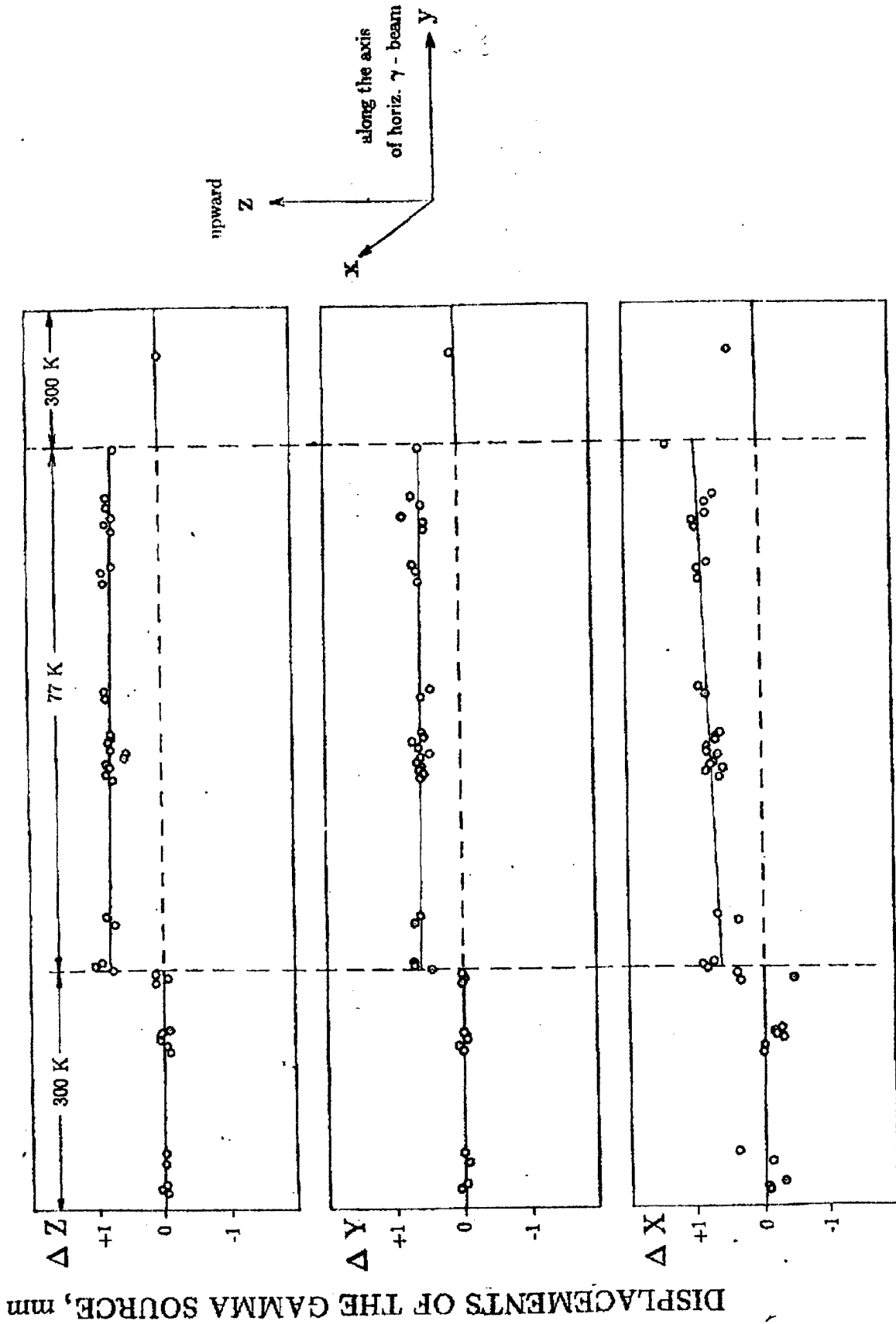

Fig. 1.

Fig 2



DISPLACEMENTS OF THE GAMMA SOURCE, mm