

July 1997

DCIEM No. 97-TM-38

DCIEM/HPP
Metabolic Measurement Software V1.0
Users' Manual



Allan Keefe
Jan Pope

Defence and Civil Institute of Environmental Medicine
1133 Sheppard Ave W, P.O. Box 2000
North York, Ontario
Canada, M3M 3B9

DTIC QUALITY INSPECTED 2

©HER MAJESTY THE QUEEN IN RIGHT OF CANADA (1997)
as represented by the Minister of National Defence

©SA MAJESTE LA REINE EN DROIT DU CANADA (1997)
Défense Nationale Canada

DEPARTMENT OF NATIONAL DEFENCE — CANADA

DISTRIBUTION STATEMENT A

Approved for public release;
Distribution Unlimited

19970916 035

Executive Summary

Measurement of metabolic parameters at rest and exercise is fundamental to the research conducted by the members of the Human Performance and Protection Sector of DCIEM. These data are normally measured by a metabolic measurement system consisting of gas analysers, a flow transducer and computer based data acquisition. Currently, there are numerous variations of hardware and software in use by the sector. As the operator must become familiarized with a variety of systems, the problems of inter-system variability and operator error are introduced. Furthermore, the compiled software was not malleable or available for verification of the metabolic calculations. As a result of these concerns, a new customized metabolic measurement software was developed. This software can be easily configured to work with any hardware system, is easy to learn, and adaptable to any future requirements. The following documentation is intended as a user manual, detailing the operation of the DCIEM/HPP Metabolic Measurement Software v 1.0.

Table of Contents

EXECUTIVE SUMMARY	I
INTRODUCTION	1
GETTING STARTED	1
MAIN SCREEN OVERVIEW	2
VIEW INPUTS	3
CALIBRATE	4
1. Flow calibration	4
2. Gas Calibration	5
STRESS TEST	7
1. Data Screen	7
2. Menu bar	8
2.1. File	8
2.2. Subject Information	10
2.3. Environmental Data	10
2.4. Test Setup	11
2.5. Variables Displayed	12
2.6. Data Collection	13
3. Validation and Reliability of the System	14
3.1. Validation of the System	14
3.2. Reliability of the System	16
APPENDIX A	17
APPENDIX B	19
APPENDIX C	21
ACKNOWLEDGMENTS	24

List of Figures

FIGURE 1. PROGRAM MANAGER ICON	1
FIGURE 2. MAIN MENU	2
FIGURE 3. VIEW INPUTS SCREEN	3
FIGURE 4. FLOW VOLUME SCREEN	4
FIGURE 5. FLOW CALIBRATION SCREEN	5
FIGURE 6. GAS CALIBRATION GASES	5
FIGURE 7. GAS CALIBRATION VOLTAGES	6
FIGURE 8. GAS CALIBRATION SUMMARY SCREEN	6
FIGURE 9. DATA SCREEN	7
FIGURE 10. DATA SCREEN MENU BAR	8
FIGURE 11. OPEN PREVIOUS TEST DATA (.DAT) DIALOG BOX	8
FIGURE 12. SAVE METABOLIC DATA (.MMS) DIALOG BOX	9
FIGURE 13. SUBJECT INFORMATION SCREEN	10
FIGURE 14. ENVIRONMENTAL DATA SCREEN	10
FIGURE 15. TEST SETUP SCREEN	11
FIGURE 16. VARIABLES DISPLAYED SCREEN	12
FIGURE 17. SAMPLE DATA COLLECTION SCREEN DURING A TEST.	13
FIGURE 18. SAMPLE PRINTED TEST DATA	14
FIGURE 19. VALIDATION OF THE SYSTEM	15
FIGURE 20. RELIABILITY OF THE SYSTEM	16
FIGURE 21. SCHEMATIC OF THE METABOLIC MEASUREMENT SYSTEM HARDWARE	20

INTRODUCTION

The DCIEM/HPP Metabolic Measurement System (MMS) software is a MS Windows program designed to run on any IBM-PC compatible computer which has at least 4 MB of RAM and a Keithly Metrabyte DAS-8 or 800 series A/D board installed. This software was designed to provide a standardized, user-friendly and customizable system for metabolic data collection. A further advantage is its capabilities of using almost any model of gas analysers and ventilation monitors in the DCIEM inventory with little, if any, modifications to the software.

GETTING STARTED

Starting the program is as simple as double clicking on the MMS icon located on the Windows Program Manager (Fig. 1).

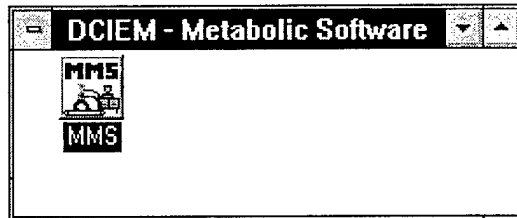

Figure 1. Program manager icon

Upon launching the program, the first screen that you will be presented with is the "Main Menu" (Fig. 2).

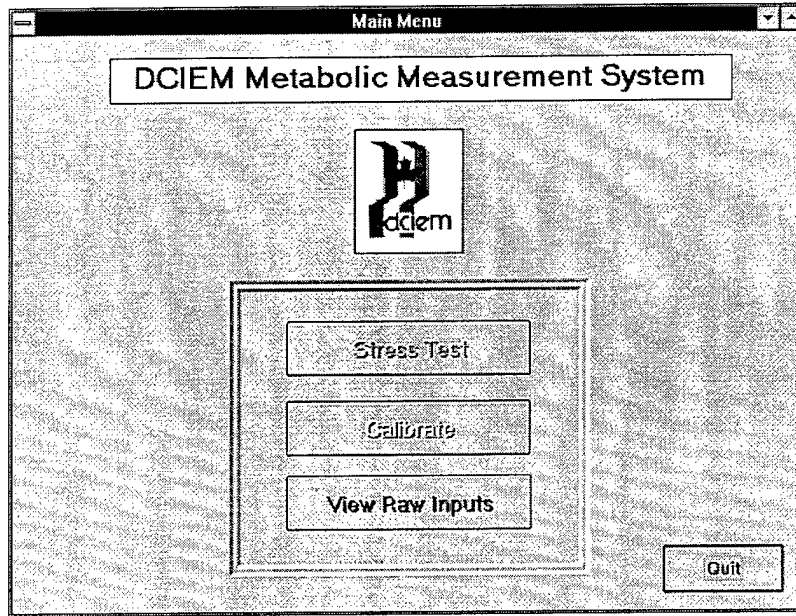

Figure 2. Main menu

From this screen, you will be able to navigate through the three primary components of this software. The options that you are presented with are as follows:

- 1) **Stress Test** Perform an exercise stress test and collect subjects' metabolic data
- 2) **Calibrate** Calibrate gas analyzers and flow transducer
- 3) **View Raw Inputs** Displays the current value of all analog channels and counters in real time, to verify proper functioning of each apparatus.

MAIN SCREEN OVERVIEW

In order to ensure accurate and trouble-free data collection, it is recommended that the user follow the sequence of verification (**View Raw Inputs**), calibration (**Calibrate**) and then data collection (**Stress Test**). Following these procedures in the sequence described will greatly enhance the probability of a successful test and simplify any troubleshooting efforts which may be required.

VIEW INPUTS

Status Result	
Loading	

Acquired Value		Channel
-5.002442	O2 Volts	0
-5.002442	CO2 Volts	1
0	Breath Switch	2

0 = no breath
5 = breath

Flow Counter	# Breaths
0	0

STOP

Figure 3. View inputs screen

Viewing inputs allows real-time simultaneous monitoring of all analyser voltages and flow transducer inputs. It is best used as a troubleshooting aid and system check to validate the proper functioning of all devices **before each metabolic run**.

Once you are satisfied that all gas analysers and the flow transducer are correctly connected to the metabolic interface box, which is in turn connected to the DAS 800 A/D card in the computer via the 32 pin cable, vary the outputs of the gas analysers by drawing an expired breath through them, or push air through the ventilation monitor. You should notice the changing voltage and pulse outputs being reflected on the "View Inputs" screen (Fig. 3). If any of the channels are not being properly updated, check all cables for proper connections. **If you must disconnect any cables, please exit Windows and turn off the computer.** The data acquisition card is very sensitive to electrical spikes and is easily damaged. Rebooting the computer has the added advantage of resetting any hardware or software problems which may have been responsible for invalid readings.

CALIBRATE

Calibration routines are provided for both the flow transducer and gas analysers.

1. Flow calibration

Flow calibration requires counting the number of pulses generated by the flow transducer for a given volume of air. The volume of the calibration syringe is entered on the "Flow Volume" (Fig. 4).

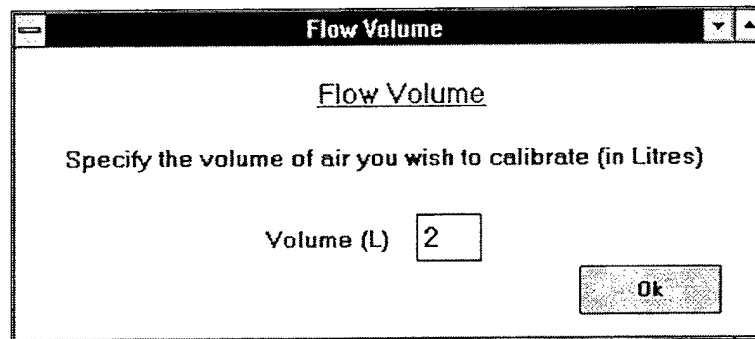

The image shows a software dialog box titled "Flow Volume". Inside the dialog, the text "Flow Volume" is centered at the top. Below it, the instruction "Specify the volume of air you wish to calibrate (in Litres)" is displayed. A text input field labeled "Volume (L)" contains the number "2". To the right of the input field is an "Ok" button.

Figure 4. Flow volume screen

This volume of air is introduced through the flow transducer at a known rate. This flow rate is normally matched to the ventilation levels measured during the actual stress test (resting, walking, maximal exercise). The default flow rate for the stress test calibration is 50 L/min. Various rates can be calibrated by selecting the flow rate spin buttons (up/down arrows) (Fig 5.). This will affect the rate of the animation sequence of the syringe icon. By using a calibrated syringe to introduce the flow into the transducer, and following the animated icon, the required flow rate can be accurately produced.

Clicking on "Begin Flow" resets the # of pulses counted to 0, initiates the animated icon and begins measuring the pulse output from the flow transducer. Once the desired volume of air has been pushed through the flow transducer, clicking "Flow Complete" will display the number of pulses that have been counted. Depending on the configuration of the KL Engineering flow transducers, one should expect in the order of either 100 (normal) or 123 (high resolution) pulses per litre of air.

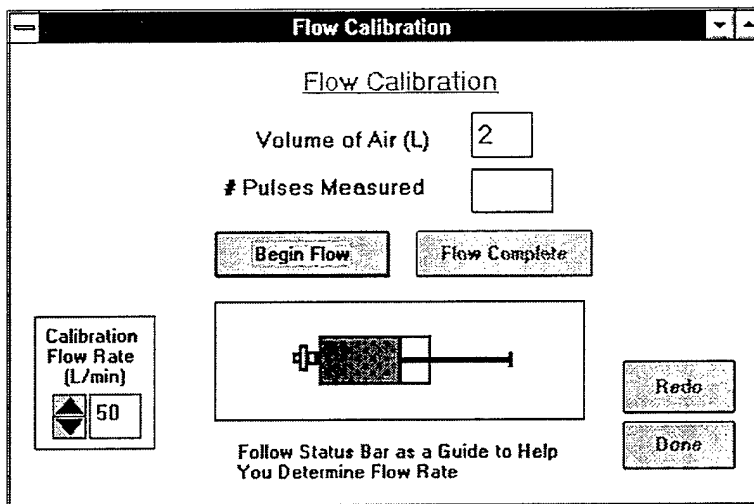

Figure 5. Flow calibration screen

2. Gas Calibration

Gas Calibration requires the flow of two previously calibrated gases through the gas analysers. As each gas is introduced, the user is prompted to enter the current O₂ and CO₂ concentrations (Fig. 6). Upon clicking "Calibrate", the gas analysers are read by the data acquisition system (Fig. 7), and a calibration slope and intercept are calculated. The calibration slope and intercept are utilized by the MMS software to convert the voltage outputs from the O₂ and CO₂ analysers to known gas concentrations.

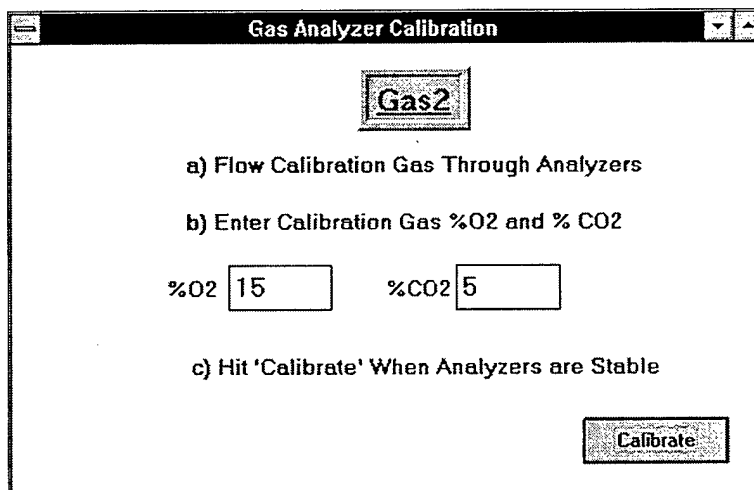

Figure 6. Gas calibration gases

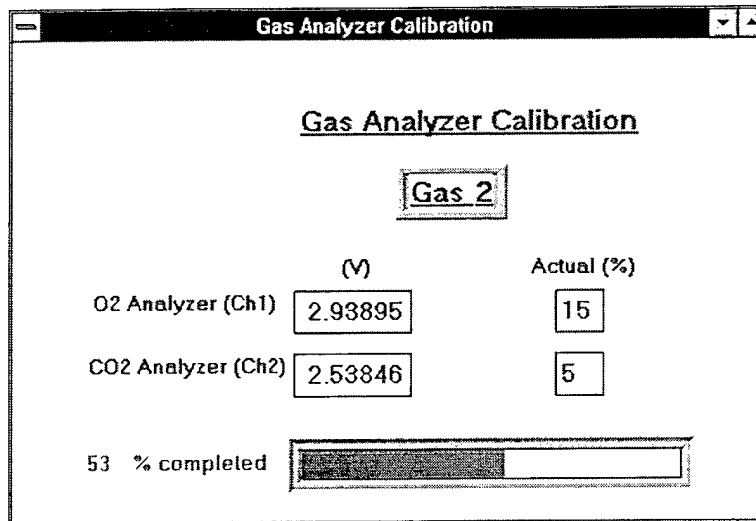

Figure 7. Gas calibration voltages

After the second gas is analysed, a summary report is generated which displays the data from the calibration (Fig. 8). This information is useful for verification of the quality of the calibration. For instance, the Ametek S-3A analyzer output range is 0 to 5V for 0 to 25% O₂, while the Ametek CD-3A's output range is 0 to 5V for 0 to 10% CO₂. Thus a calibration gas of 15% O₂ and 5% CO₂ should result in an output of 3V and 2.5V respectively. If the calibration summary is suspect, the entire calibration procedure maybe repeated by clicking 'Recalibrate'.

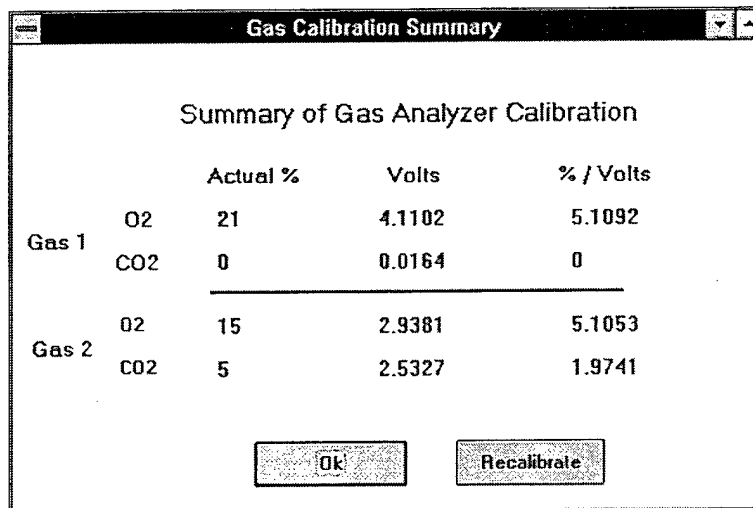

Figure 8. Gas calibration summary screen

allowed to proceed. FeO₂ and FeCO₂ are also continuously updated for monitoring purposes during the test.

2. Menu bar



Figure 10. Data screen menu bar

The menu bar (Fig. 10) contains the subject, environmental and test options that you will need to complete before initiating collection of metabolic data. These data are best entered by selecting each option from left to right and completing the requested data screens.

2.1. File

This menu item allows the retrieval and storage of subject, environmental and test setup data. Test data are stored in two files having the syntax <filename.DAT> and <filename.MMS>. These files are only created when the user wishes to save the metabolic data to a file (see **Test Setup**). The files with the ".DAT" extensions contain all the relevant test parameters, while the files with the ".MMS" extensions are tab delimited text files containing the actual metabolic data. This data can be retrieved by any spreadsheet or text editor. By clicking on "File...Open", the following dialog box appears, prompting the user to select previous test parameters.

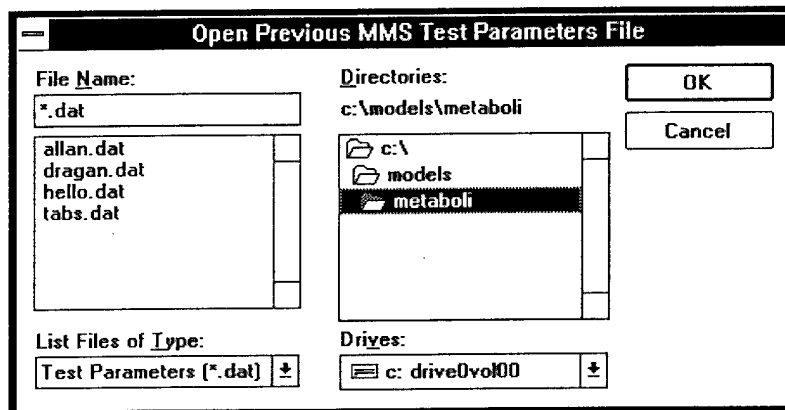

Figure 11. Open previous test data (.DAT) dialog box

If the software detects that the previous test parameters requested the data to be saved to a file, a second dialog box will appear, prompting the user to enter a filename for the data to be stored.

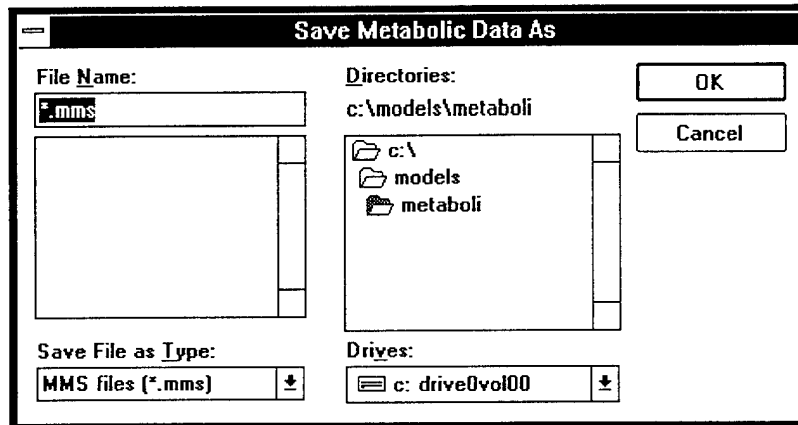
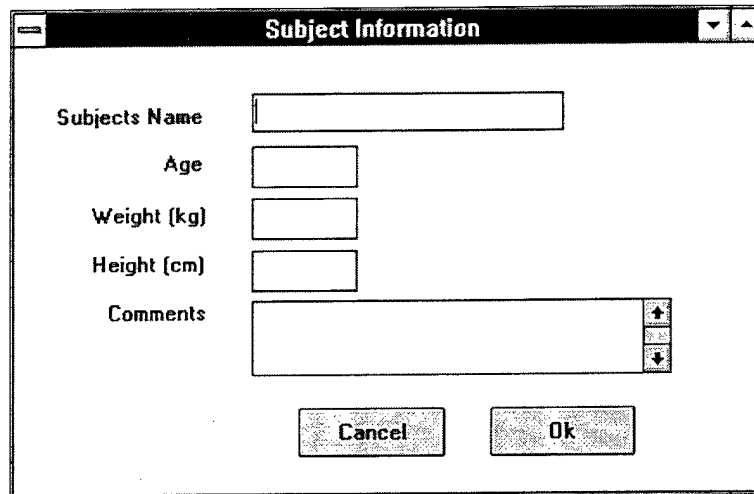

Figure 12. Save metabolic data (.MMS) dialog box

Note: It is not necessary to type in the .MMS or .DAT extensions. They will be appended to the filename automatically.

The file menu options also include "File...Save .DAT File" which allows the user to save only the test parameters, without the creation of a .MMS file, and a "File...Exit" option which returns the program to the **Main Screen**.

2.2. Subject Information



A dialog box titled "Subject Information" with a standard Windows window border. It contains five input fields: "Subjects Name" (a long text box), "Age" (a short text box), "Weight (kg)" (a short text box), "Height (cm)" (a short text box), and "Comments" (a larger text box with vertical scroll bars). At the bottom are "Cancel" and "Ok" buttons.

Figure 13. Subject information screen

This screen allows the user to input anthropometric and general identification information regarding the subject. **Note: Age, weight and height** are required information, and the stress test program will not run without this information.

2.3. Environmental Data

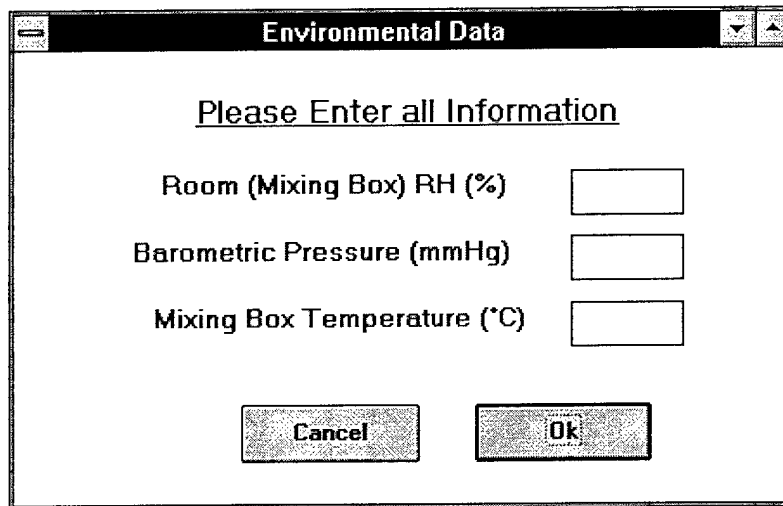

A dialog box titled "Environmental Data" with a standard Windows window border. It contains the instruction "Please Enter all Information" centered at the top. Below it are three input fields: "Room (Mixing Box) RH (%)", "Barometric Pressure (mmHg)", and "Mixing Box Temperature (°C)". At the bottom are "Cancel" and "Ok" buttons.

Figure 14. Environmental data screen

Environmental parameters are entered on this form. All of this data is required to proceed with the test. Please note that since expired ventilation is being measured, the relative humidity and temperature inputs should be from the **mixing box**, not the ambient environment. Mixing box relative humidity is assumed to be 100% for expired air. For tests conducted at normal room temperatures of 20 to 25 °C , a mixing box temperature of 25 °C is used. Alternatively, the mixing box temperature may be measured directly with a thermistor during pilot studies.

2.4. Test Setup

The screenshot shows a window titled "Test Setup". It contains the following elements:

- "Inspired O2 (%)" input field with the value "20.93".
- "Inspired CO2 (%)" input field with the value ".0300".
- A shaded box titled "Select Averages to be Saved" containing:
 - Radio buttons for "15 Sec", "30 Sec", and "60 Sec".
 - A "user defined (mins)" label next to an empty input field.
- Checkboxes for "Print Data at End of Test" (unchecked) and "Send Output to File" (checked).
- "Cancel" and "OK" buttons.

Figure 15. Test setup screen

Various parameters selected on the "Test Setup" screen allow the user greater customization of how the test is performed.

If gas mixtures other than room air are being used, then the new inspired percent O₂ and CO₂ may be entered at this point. Otherwise, the default values of 20.93% O₂ and .03% CO₂ will be used for the test.

Data averaging is determined by choosing either one of the three default options (15, 30 or 60 second periods), or as defined by the user (in minutes). This option controls the updating of the second larger grid on the stress test display.

Finally, the last two options allow the user control of the test results output. None, one, or both of these output options may be selected. By selecting "Send Output to File" all of the stress test data calculated, whether displayed or

not, will be sent to an MS Excel-compatible tab-delimited file. You will be prompted for a file name and path if this option is selected.

If a printed report is required, simply click this option and a full report will be generated at the end of the test. This report contains **only the data selected to be displayed**. See section 2.5 Variables Displayed for more detail. **Important:** make sure that a printer is properly connected, turned on and selected by the Print Manager as the default printer, or you may experience problems printing your data. If in doubt, it is always safest to save the file to disk.

2.5. Variables Displayed

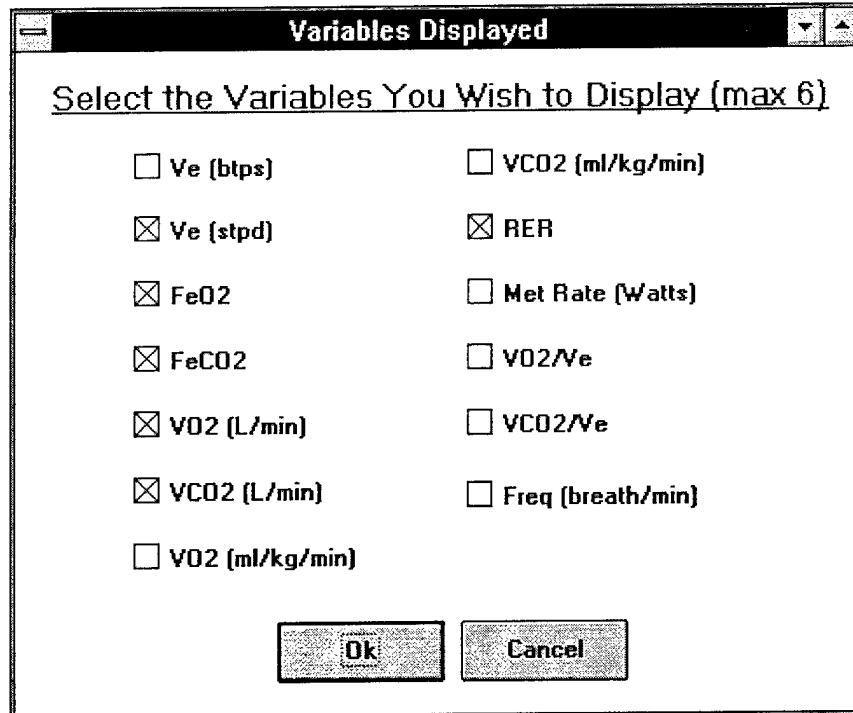

Figure 16. Variables displayed screen

The "Variables Displayed" screen allows the user to customize the display grids to monitor the metabolic variables most relevant to the particular test. A maximum of six variables may be selected; however, one can return to this screen at any time during the ongoing test and reselect the variables. The grids will reflect this change only from the latest reading.

2.6. Data Collection

Figure 17 illustrates the "Data Screen" during a typical test. In this example, the current test summary data appears in the left information box, while the 15 second updates appear in the upper grid. In this test, metabolic data were calculated as minute averages every 30 seconds. These data appear in the lower grid. Note that the data appearing on the grids were determined by the "Variables Displayed" screen illustrated by figure 16.

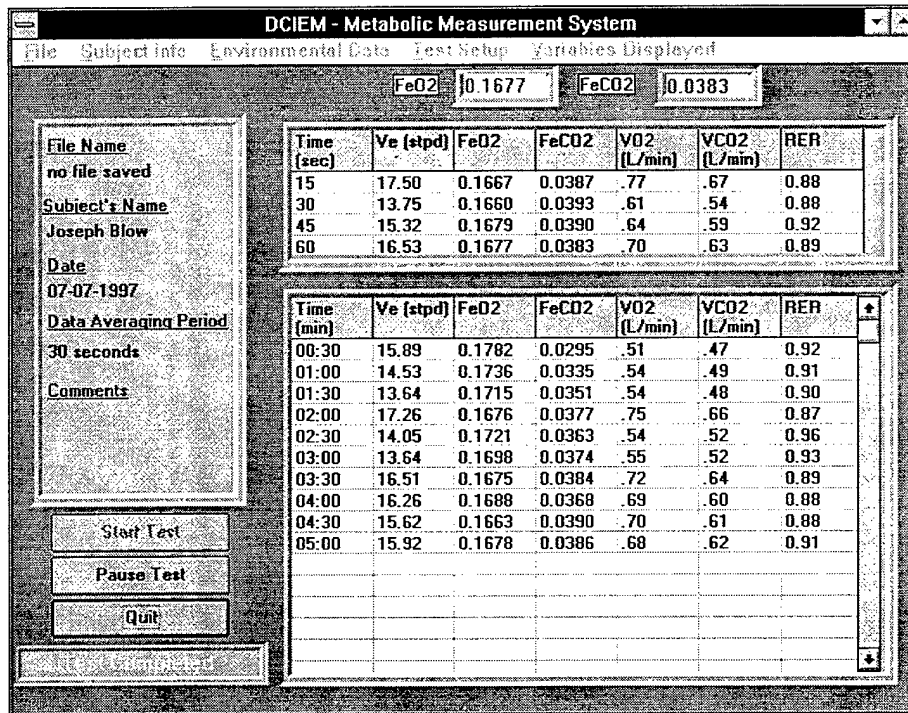

Figure 17 Sample data collection screen during a test.

If the printed output option is selected, a printout of the test data will be produced at the conclusion of data collection (Figure 18). Again, the data printed are those selected from the "Variables Displayed" screen (Figure 16). For a more comprehensive record of metabolic data variables, save the data to file.

DCIEM Metabolic Measurement System

Test Date: 07-07-1997

File Name:

Subject's Name: Joseph Blow

Height (cm): 180

Weight (kg): 77

Age: 35

Barometric Pressure (mmHg): 760

Mixing Box Temperature (C): 25

Mixing Box RH (%): 100

Comments:

Time (min)	Ve (stpd)	FeO2	FeCO2	VO2 (L/min)	VCO2 (L/min)	RER
00:30	15.89	0.1782	0.0295	.51	.47	0.92
01:00	14.53	0.1736	0.0335	.54	.49	0.91
01:30	13.64	0.1715	0.0351	.54	.48	0.90
02:00	17.26	0.1676	0.0377	.75	.66	0.87
02:30	14.05	0.1721	0.0363	.54	.52	0.96
03:00	13.64	0.1698	0.0374	.55	.52	0.93
03:30	16.51	0.1675	0.0384	.72	.64	0.89
04:00	16.26	0.1688	0.0368	.69	.60	0.88
04:30	15.62	0.1663	0.0390	.70	.61	0.88
05:00	15.92	0.1678	0.0386	.68	.62	0.91

Figure 18 Sample printed test data

3. Validation and Reliability of the System

3.1. Validation of the System

Four males and three females performed five minutes of exercise on a bicycle ergometer at each of five increasing workloads. The metabolic system described was connected in series with a Tissot gasometer and Ametek oxygen and carbon dioxide analysers, the latter being considered the "gold standard" for such measurements. The last minute of exercise at each workload was used to collect expired air in the gasometer for subsequent analyses of ventilation and expired gas concentrations. Oxygen consumption was calculated in accordance with well established equations for open circuit spirometry. Figure 19 depicts a scattergram of oxygen consumption for the "cart" vs. the "tissot". A Fisher's F-test indicated no significant difference between the two systems and the line of identity. Therefore, this new software/hardware system can be considered to be valid and accurate.

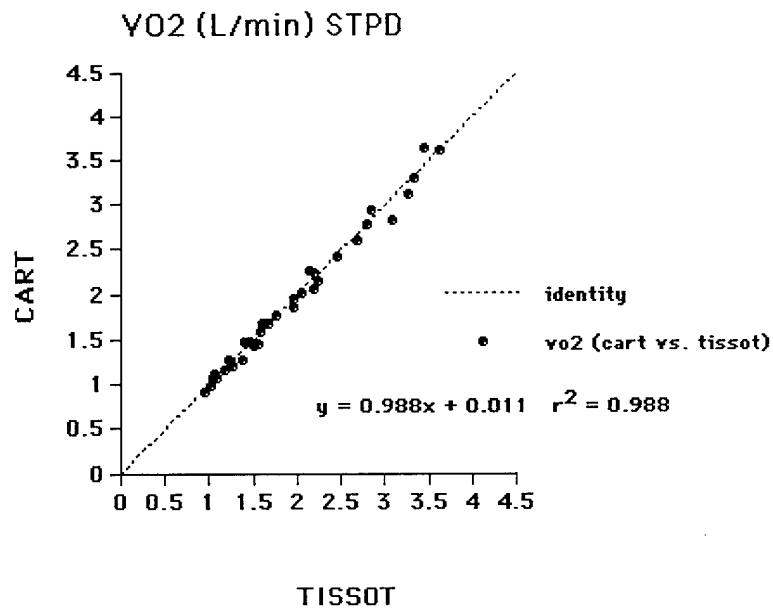

Figure 19. Validation of the System

3.2. Reliability of the System

Five males performed a maximal oxygen consumption test on a treadmill as a prerequisite for participation in a heat stress experiment. The protocol consisted of running at a self-determined speed with an increase in grade of 1% per minute until exhaustion. After completion of the heat stress trial, a "post" determination of maximal oxygen consumption was performed in exact accordance to the "pre" evaluation. Figure 20 depicts a scattergram of oxygen consumption for the "pre" vs. the "post" trials at the same treadmill speeds and % grade during the incremental test. A Fisher's F-test indicated no significant difference between the two days and the line of identity. This new software/hardware system can be considered to be reliable and reproducible.

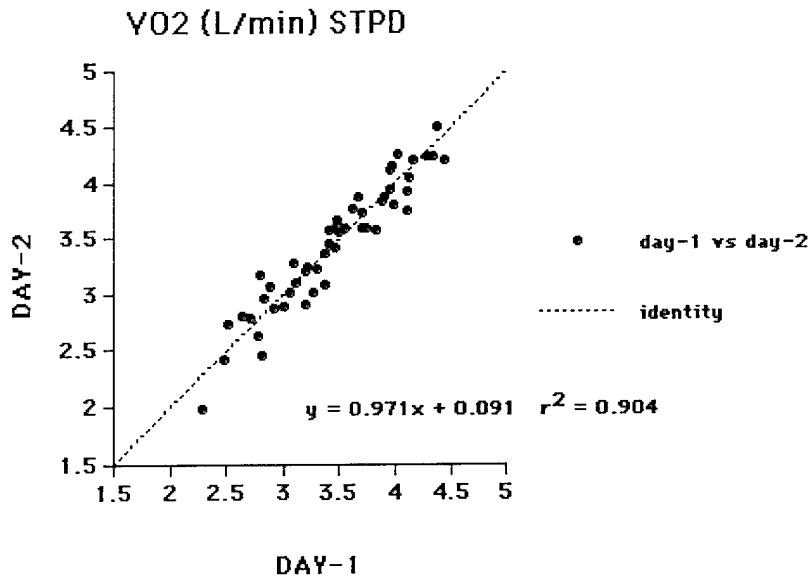

Figure 20. Reliability of the System

Appendix A

Pin Out Tables

DAS 8/800 main I/O connector (37 pin)

<u>Pin number</u>	<u>Function</u>	<u>Variable Measured</u>
2	clk 0	flow
12 to 18	low level common	ground
29	+5V	+5V to flow transducer
37	analog ch 1	%O ₂
36	analog ch 2	%CO ₂
35	analog ch 3	respiration

KL Engineering KTC-3D

<u>Pin Number</u>	<u>Variable</u>
2	Power supply ground
4	flow (100 PPL)
5	flow (123 PPL)
6	Respiration (0-5 V)
7	Power supply +5V

Appendix B

Hardware Schematics

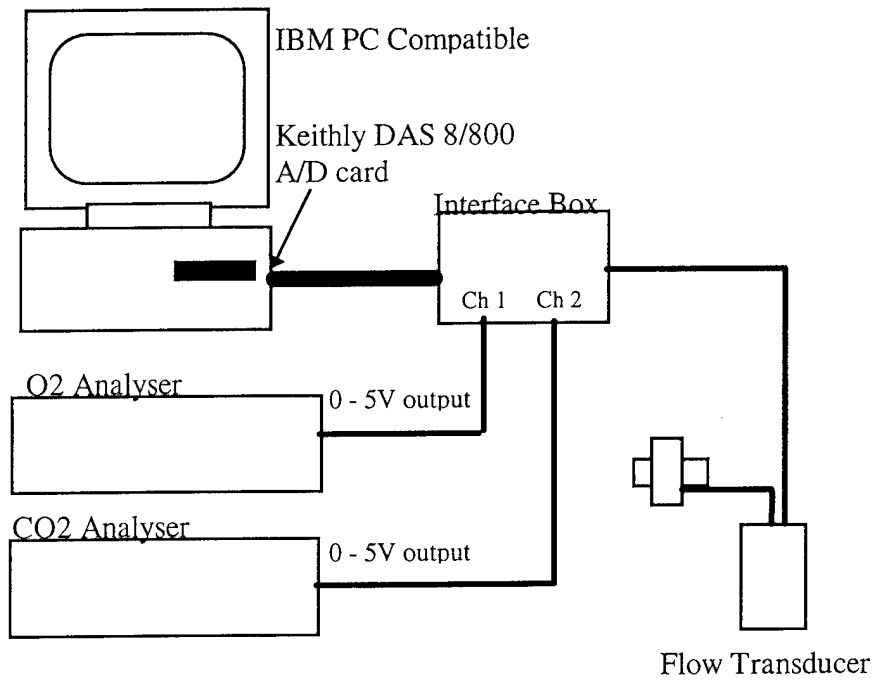

Figure 21. Schematic of the Metabolic Measurement System Hardware

Appendix C

Metabolic Calculations

Summary of metabolic formulae used in the calculation of metabolic data.

$$F_{I}N_2 = 1 - (F_{I}CO_2 + F_{I}O_2)$$

$$F_{E}N_2 = 1 - (F_{E}CO_2 + F_{E}O_2)$$

$$\dot{V}_{I(ATP)} = \dot{V}_{E(ATP)} \times \frac{F_{E}N_2}{F_{I}N_2} \quad (l \cdot \text{min}^{-1})$$

$$\dot{V}_{E(BTPS)} = \dot{V}_{E(ATP)} \times \frac{(273.23 + T_B)}{(273.23 + T_A)} \times \frac{(P_B - P_{H_2O(A)})}{(P_B - P_{H_2O(B)})} \quad (l \cdot \text{min}^{-1})$$

$$\dot{V}_{E(STPD)} = \dot{V}_{I(STPD)} \times \frac{F_{I}N_2}{F_{E}N_2} \quad (l \cdot \text{min}^{-1})$$

$$\dot{V}O_2 = \dot{V}_{I(STPD)} \times (F_{I}O_2) - (\dot{V}_{E(STPD)} \times F_{E}O_2) \quad (l \cdot \text{min}^{-1})$$

$$\dot{V}CO_2 = \dot{V}_{E(STPD)} \times (F_{E}CO_2) - (\dot{V}_{I(STPD)} \times F_{I}CO_2) \quad (l \cdot \text{min}^{-1})$$

$$RQ = \frac{\dot{V}CO_2}{\dot{V}O_2}$$

$$\text{Energy} = 352 \times (.23 \times RQ + .77) \times \dot{V}O_2 \quad (\text{W})$$

$$SA = .202 \times wt^{.425} \times ht^{.725} \quad (\text{m}^2)$$

$$P_{H_2O(A)} = 4.579 \times 10^{\frac{7.5 \times T_A}{T_A + 273.23}} \times \frac{RH}{100} \quad (\text{mmHg})$$

$$P_{H_2O(B)} = 4.579 \times 10^{\frac{7.5 \times T_B}{T_B + 273.23}} \quad (\text{mmHg})$$

Where:

$F_{I}N_2$ = Inspired fraction

$F_{E}N_2$ = Expired fraction

\dot{V}_I = Inspired minute ventilation

\dot{V}_E = Expired minute ventilation

STPD = Standard temperature and pressure, dry

ATPS = Ambient temperature and pressure, saturated

P_B = Barometric pressure (mmHg)

RH = Relative humidity (%)

SA = Body surface area (m²)

wt = body weight (kg)

ht = height (m)

P_{H₂O(s)} = Water vapour pressure (ambient or body temperature)

T_A = Ambient temperature (°C)

T_B = Body temperature (37°C)

Acknowledgments

The authors would like to thank Dr. P Tikuisis for his assistance with the statistical analysis of the validity and reliability data, and Dr. T McLellan for his physiological and editing expertise.

Unclass.

SECURITY CLASSIFICATION OF FORM
(Highest classification of Title, Abstract, Keywords)

DOCUMENT CONTROL DATA

(Security classification of title, body of abstract and indexing annotation must be entered when the overall document is classified)

<p>1. ORIGINATOR (the name and address of the organization preparing the document. Organizations for whom the document was prepared, e.g., Establishment sponsoring a contractor's report, or tasking agency, are entered in section 12.)</p> <p>DCIEM 1133 Sheppard Ave W. Downsview, Ont. M3M 3B9</p>	<p>2. DOCUMENT SECURITY CLASSIFICATION (overall security classification of the document including special warning terms if applicable)</p> <p style="text-align: center;">Unclassified</p>
---	--

3. DOCUMENT TITLE (the complete document title as indicated on the title page. Its classification should be indicated by the appropriate abbreviation (S,C,R or U) in parentheses after the title.)
DCIEM/HPP Metabolic Measurement Software v1.0 - Users' Manual

4. DESCRIPTIVE NOTES (the category of the document, e.g., technical report, technical note or memorandum. If appropriate, enter the type of report, e.g. interim, progress, summary, annual or final. Give the inclusive dates when a specific reporting period is covered.)

Technical memorandum

5. AUTHOR(S) (Last name, first name, middle initial. If military, show rank, e.g. Burns, Maj. Frank E.)
Keefe, Allan A.
Pope, J

<p>6. DOCUMENT DATE (month and year of publication of document)</p> <p style="text-align: center;">July 97</p>	<p>7.a. NO. OF PAGES (total containing information. Include Annexes, Appendices, etc.)</p> <p style="text-align: center;">23</p>	<p>7.b. NO. OF REFS. (total cited in document)</p> <p style="text-align: center;">0</p>
--	--	---

<p>8.a. PROJECT OR GRANT NO. (if appropriate, the applicable research and development project or grant number under which the document was written. Please specify whether project or grant)</p>	<p>8.b. CONTRACT NO. (if appropriate, the applicable number under which the document was written)</p>
--	---

<p>9.a. ORIGINATOR'S DOCUMENT NUMBER (the official document number by which the document is identified by the originating activity. This number must be unique to this document.)</p>	<p>9.b. OTHER DOCUMENT NO.(S) (any other numbers which may be assigned this document either by the originator or by the sponsor.)</p>
---	---

10. DOCUMENT AVAILABILITY (any limitation on further dissemination of the document, other than those imposed by security classification)

<input checked="" type="checkbox"/>	Unlimited distribution
<input type="checkbox"/>	Distribution limited to defence departments and defence contractors; further distribution only as approved
<input type="checkbox"/>	Distribution limited to defence departments and Canadian defence contractors; further distribution only as approved
<input type="checkbox"/>	Distribution limited to government departments and agencies; further distribution only as approved
<input type="checkbox"/>	Distribution limited to defence departments; further distribution only as approved
<input type="checkbox"/>	Other

11. ANNOUNCEMENT AVAILABILITY (any limitation to the bibliographic announcement of this document. This will normally correspond to the Document Availability (10.) However, where further distribution (beyond the audience specified in 10) is possible, a wider announcement audience may be selected.)

12. SPONSORING ACTIVITY (the name of the department project office or laboratory sponsoring the research and development. Include the address.)

DSIS DCD03
HFD 09/94

Unclass.

SECURITY CLASSIFICATION OF FORM
(Highest classification of Title, Abstract, Keywords)

Unclass.

SECURITY CLASSIFICATION OF FORM
(Highest classification of Title, Abstract, Keywords)

13. ABSTRACT (a brief and factual summary of the document. It may also appear elsewhere in the body of the document itself. It is highly desirable that the abstract of classified documents be unclassified. Each paragraph of the abstract shall begin with an indication of the security classification of the information in the paragraph (unless the document itself is unclassified) represented as (S), (C), (R), or (U). It is not necessary to include here abstracts in both official languages unless the text is bilingual).

Measurement of metabolic parameters at rest and exercise is fundamental to the research conducted by the members of the Human Performance and Protection Sector of DCIEM. These data are normally measured by a metabolic measurement system consisting of gas analysers, a flow transducer and computer based data acquisition. Currently, there are numerous variations of hardware and software in use by the sector. This introduces the problems of inter-system variability, and operator error, as the unique procedures for operating each system must become familiarized. Furthermore, the compiled software was not malleable or available for verification of the metabolic calculations. As a result of these concerns, a new customized metabolic measurement software was developed. This software can be easily configured to work with any hardware system, is easy to learn, and adaptable to any future requirements. The following documentation is intended as a user manual, detailing the operation of the DCIEM/HPP Metabolic Measurement Software v 1.0.

14. KEYWORDS, DESCRIPTORS or IDENTIFIERS (technically meaningful terms or short phrases that characterize a document and could be helpful in cataloguing the document. They should be selected so that no security classification is required. Identifiers, such as equipment model designation, trade name, military project code name, geographic location may also be included. If possible, keywords should be selected from a published thesaurus, e.g. Thesaurus of Engineering and Scientific Terms (TEST) and that thesaurus identified. If it is not possible to select indexing terms which are Unclassified, the classification of each should be indicated as with the title.)

Metabolism, exercise, $\dot{V}O_2$, oxygen uptake, respiratory gas analysis.

Unclass.