

OUTBOARD WATERJET PROPULSION DEVELOPMENT

Third Monthly Report
1 August through 31 August, 1997
Contract: USZA22-97-P-0041

DISTRIBUTION STATEMENT A
Approved for public release;
Distribution Unlimited

19970910 086

From:
Vehicle Technology
1488 Cherry Garden Lane, San Jose, CA 95125-4843
Phone: (408) 264-5592, FAX (408) 723-5183

Classification: Unclassified

a. OUTBOARD WATERJET PROPULSION DEVELOPMENT

b. Third Monthly Report

c. 1 August through 31 August 1997

d. Contract: USZA22-97-P-0041

e. From: Vehicle Technology, 1488 Cherry Garden Lane, San Jose, CA 95125-4843

f. Classification: Unclassified

g. Distribution:

USSOCOM

Attn: SOAC-KB (Mr. Lewis Gwaltney)
7701 Tampa Point Blvd.
MacDill AFB, FL 33621-5323

USSOCOM

Attn: SOAC-DT (Dave Saren)
7701 Tampa Point Blvd.
MacDill AFB, FL 33621-5323

USSOCOM

Attn: SOSB (Karen Pera)
7701 Tampa Point Blvd.
MacDill AFB, FL 33621-5323

Coastal Systems Station (CSS)

Attn.: Code A31, (Bill McCrory)
W. Highway 98
Panama City, FL 32407.7001

Defense Technical Information Center

Attn: DTIC/SBIR
8725 John J. Kingman Road, STE 0944
Fort Belvoir, VA 22060-6218

Summary:

The project is currently on schedule. The design review meeting was held on 08/26/97 at the Coastal Systems Station in Panama City, Florida. The mechanical arrangement, performance analysis and design features were presented at the review meeting. A number of suggestions and recommendations from the participants were noted for future guidance of the project. A meeting on 27 August was held at the 2CI facility to plan the continuing engineering and design efforts by 2CI and Vehicle Technology. Some of the significant data presented is attached herewith:

Attachment A: NBOE Specification Comparison

This list shows that the proposed outboard waterjet should be able to meet the specification.

Attachment B: This diagram shows the general arrangement, with engine cover removed, of the outboard waterjet.

Attachment C: This diagram provides the major dimensions of the current design layout.

Attachment D: This shows the arrangement of the mainshaft assembly with impeller and pulley. This assembly is driven from the engine by means of a HTD toothed belt.

Attachment E: This shows the weight analysis. Jet weights were mainly proportioned from actual scale weights of a similar, but larger, jet. The engine weight was an actual scale weight of the current version of the engine.

Attachment F: This shows the estimated resistance curve for the hull based on tests of a similar size hull (no test data was available for the current hull). Thrust curves for the jet are given for 55 horsepower (the power necessary for this application) and at 70 horsepower, the normal rating of this engine. Production dynamometer results for this engine average about 73 horsepower.

A contract modification on 5 August 1997 added a demonstration of a reflex jet powered by the 2CI model 690 engine that is planned to be used for the outboard jet. The available hardware was a larger jet arranged for an inboard/outdrive installation. The primary purpose of the demonstration was to provide evidence that the unusual folded configuration of the reflex waterjet was capable of providing satisfactory performance and handling. Use of existing components minimized cost so that no increase in the contract cost was required and reductions in the analytical efforts were possible by use of the resulting test data.

A 7.34 inch impeller size reflex was installed in an aluminum boat of about the same size as the Zodiac inflatable hulls now in use. A 2CI model 690 engine with a 2.04 ratio reduction gear was installed to provide the power. This is the same engine as is planned for the outboard installation that generally matches the NBOE specification. Trial runs near the 2CI factory in Beaufort, SC confirmed satisfactory performance. The demonstration boat was towed on a trailer to the August 26, 1997 Design review meeting at the Coastal Systems Station In Panama City. The demonstration boat provided satisfactory performance and has been left at CCS for additional tests and demonstrations.

Milestone/Task Status:

A revised schedule was prepared on 7/11/97 to add the tasks associated with the "Proof of Principle" tests and demonstration. The program is currently on schedule.

Future Plans:

The performance of the demonstration boat with the 7.34" impeller size jet has been surprisingly good considering that size jet was designed for powers from 115 to 300 horsepower. In spite of this significant power mismatch performance has been good. This demonstrates a feasibility of offering an expanded range of sizes to match different requirements. Studies are now underway for the following family of reflex waterjet outboards:

1. A 5.00 inch impeller jet with a modified 2CI model 460 engine. The modification consists of a special cylinder with porting optimized for the application. The engine will produce 35 horsepower at 4,500 RPM, compared to the normal 6,250 to 6,750 rated speed for this engine. The reduced speed will increase durability, reduce noise and provide a brake specific fuel consumption rate of better than 0.50 pounds per horsepower hour. Current estimated weight is 117 pounds.
2. A 5.00 inch impeller jet with a modified 2CI model 690 engine. A minor change in belt ration will match the jet to the higher powered engine. The modification consists of the same special cylinder as used in the 35 horsepower engine. The engine will produce 55 horsepower at 4,500 RPM, compared to the normal 6,250 rated speed for this engine. The reduced speed will increase durability, reduce noise and provide a brake specific fuel consumption rate of better than 0.50 pounds per horsepower hour. Since the 460 and 690 engines are just two and three cylinder engines of the same design, most parts are interchangeable and logistic problems are correspondingly reduced. Current estimated weight is 127 pounds.
3. A 5.00 inch impeller jet with a standard 2CI model 690 engine. This would provide a higher performance alternate to the 55 horsepower version of the 690 engine. There would be compromises in noise, life and fuel economy, but there may be missions where added performance is needed. Current estimated weight is 127 pounds.
4. A 7.34 inch impeller jet with a standard 2CI model 690 engine. This would provide performance similar to the current demonstration boat. Since the engine is in current production and tooling is available for most of the jet parts, samples could be built in a few months and at relatively low cost. There would be low technical risk and it would provide early experience with the outboard configuration that could be useful in design of the 5.00" units. Estimated weight is 170 pounds.
5. A 7.34 inch impeller jet with a standard 2CI model 808 engine rated at 100 horsepower. Like the 7.34 with the 690 engine, samples could be provided quickly and economically. This unit would be suitable for larger boats and heavier loads. Estimated weight is 193 pounds.

6. A 7.34 inch impeller jet with a planned 2CI engine rated at 150 horsepower. This future unit would be suitable for much larger boats and heavier loads. Estimated weight is 213 pounds.

The current plan is to continue with the revised Phase I Schedule dated 7/11/97. At this time the effort appears to be on schedule. No unusual or unexpected problems have been encountered that could compromise the scheduled effort or the results of the project.

Prepared By:

Waldo E. Rodler
(408) 264-5592

NBOE Specification Comparison:				
	Objective	Threshold	OB Jet	Note:
Fuel Compatability	DFM F76	DFM F76	Gasoline	Current engine runs with similar fuels. Injection equipment is under development to meet added submersion requirement
Weight, pounds	150	160	128	Based mainly on scale weights
Size				
Height	49	51	30	
Length	24.75	26.75	28	Can meet 24.75 with engine & mounting modifications
Width	14.25	16.25	14.1	
Fuel Consumption, GPH	4.25	4.5	3.67 5.46	With Fuel Injection Current carburetted engine
Submersion	18 hour	18 hour	OK	Belt transfer and water lubricated bearings in jet
Manual Start	Required	Required	OK	Necessary design provisions will be made
Time to plane, seconds	20	20	17	Based on available hull data
Starting	Required	Required	OK	Necessary design provisions will be made
Power (speed in MPH)	24	20	>24	Based on available hull data
Reliability (12 hr. mission)	0.9	0.8	OK	Necessary design provisions will be made
Operational Availability	0.95	0.9	OK	Necessary design provisions will be made
Maintainability				
Field (minutes)	15	20	OK	Necessary design provisions will be made
Organization (hours)	2	3	OK	Necessary design provisions will be made
Noise levels	The absence of gearing and open prop give OB jet inherent advantage			

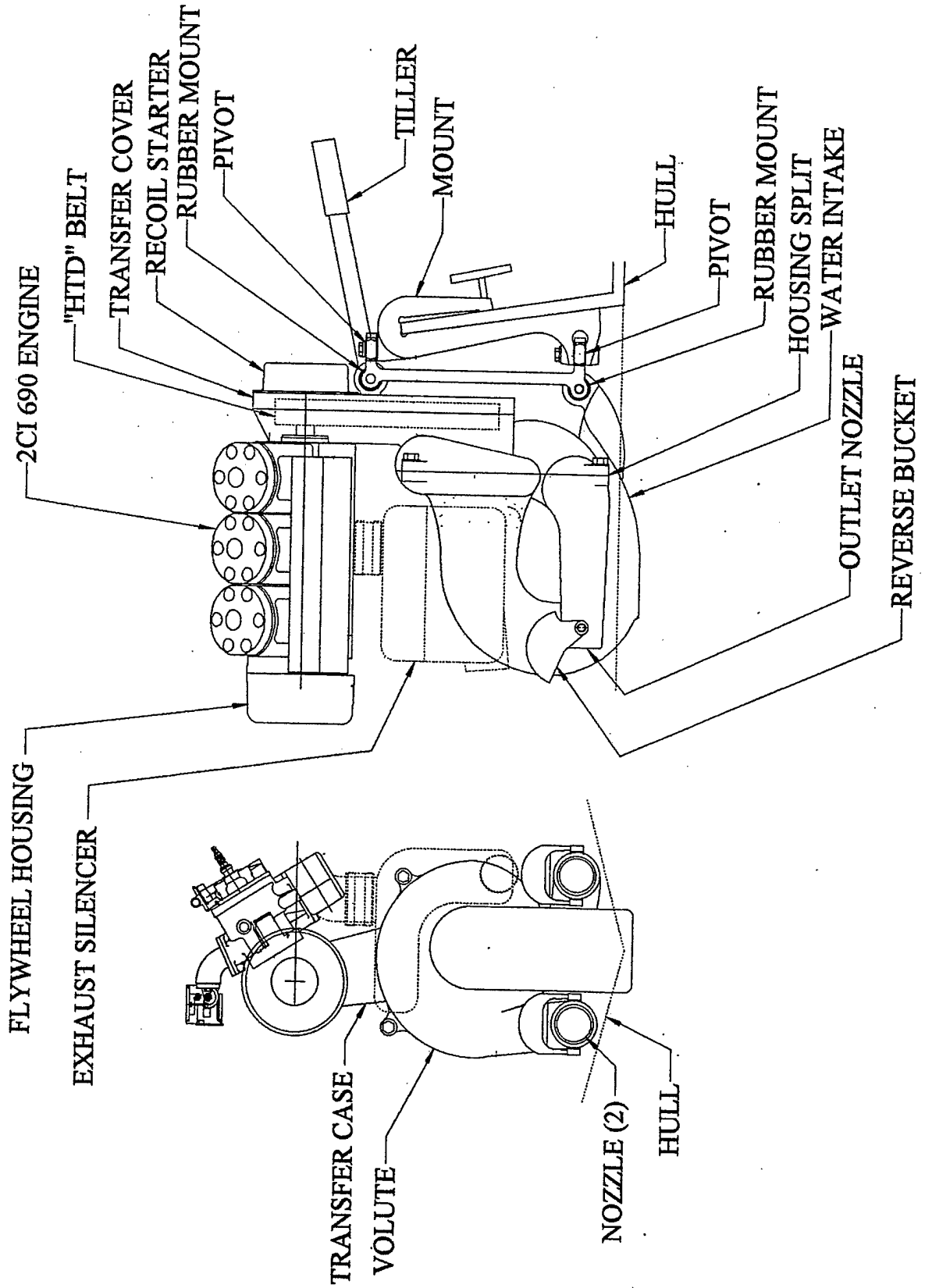

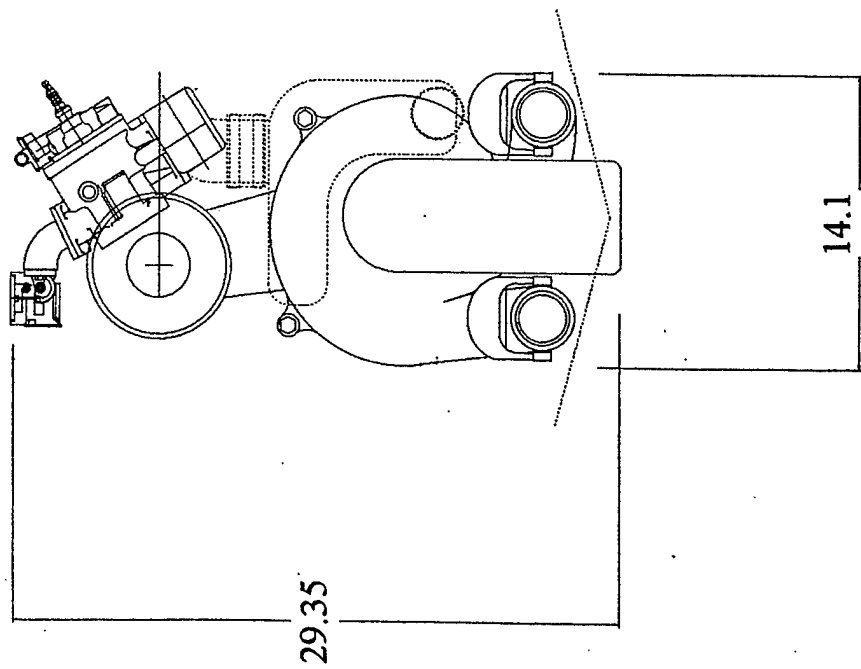
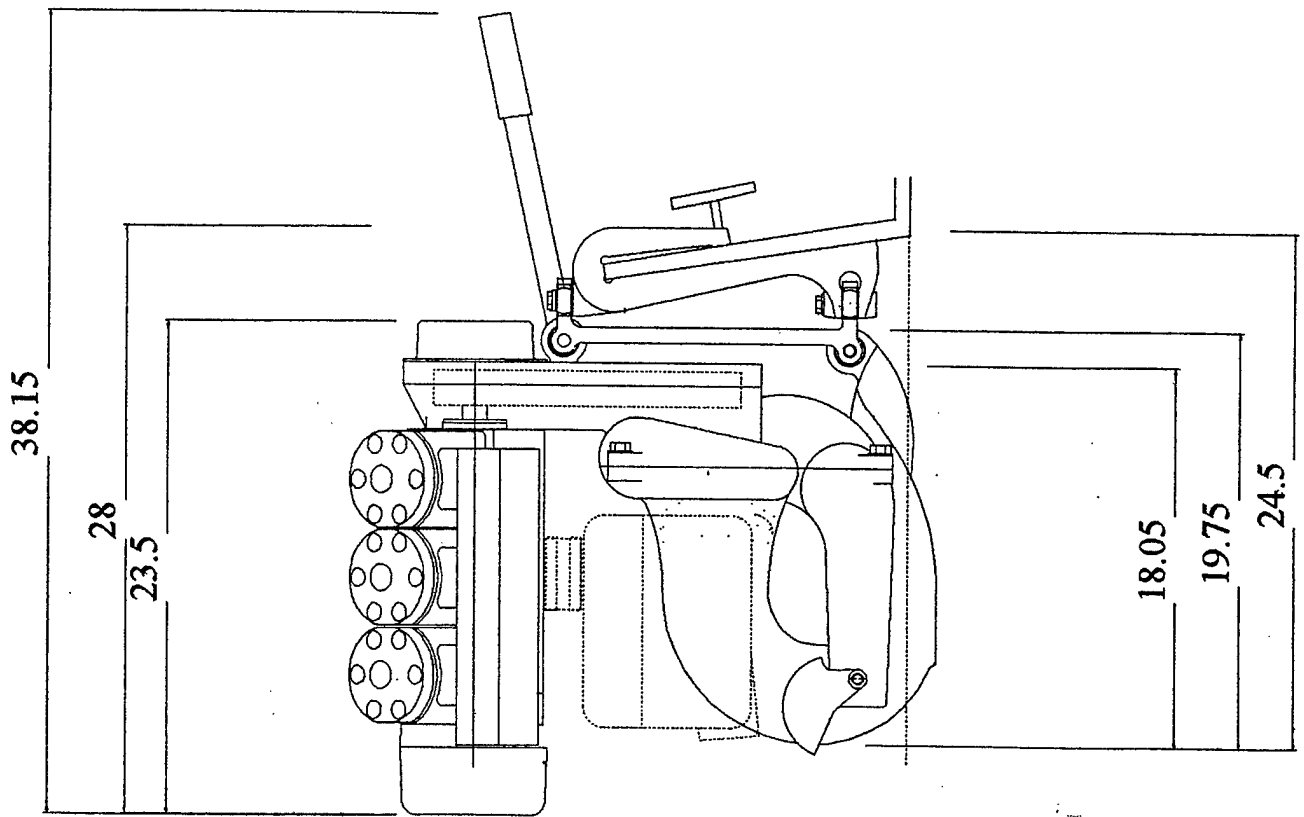

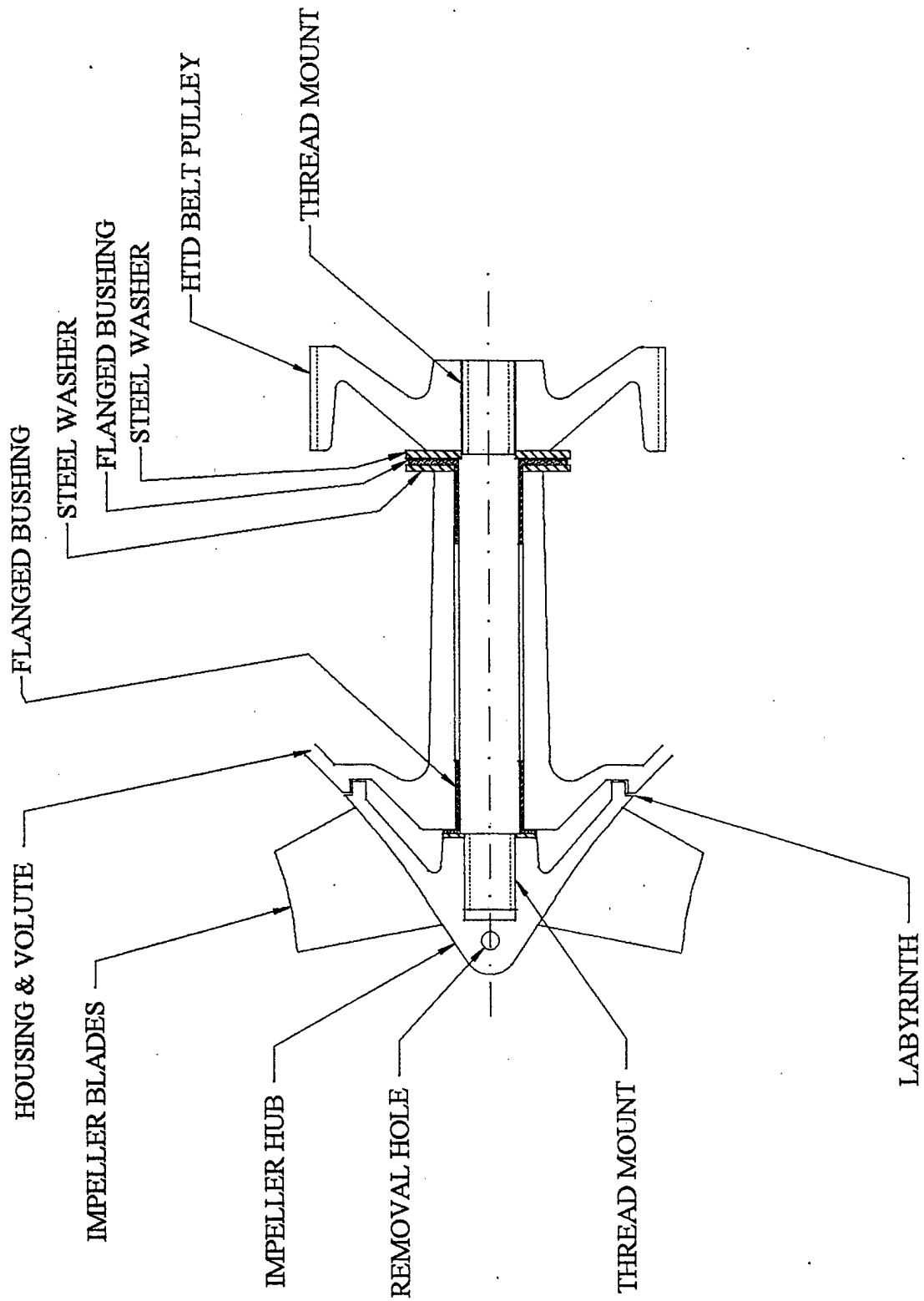

THRUST vs. DRAG

Jet Outboard vs. Sea Hawk Hull

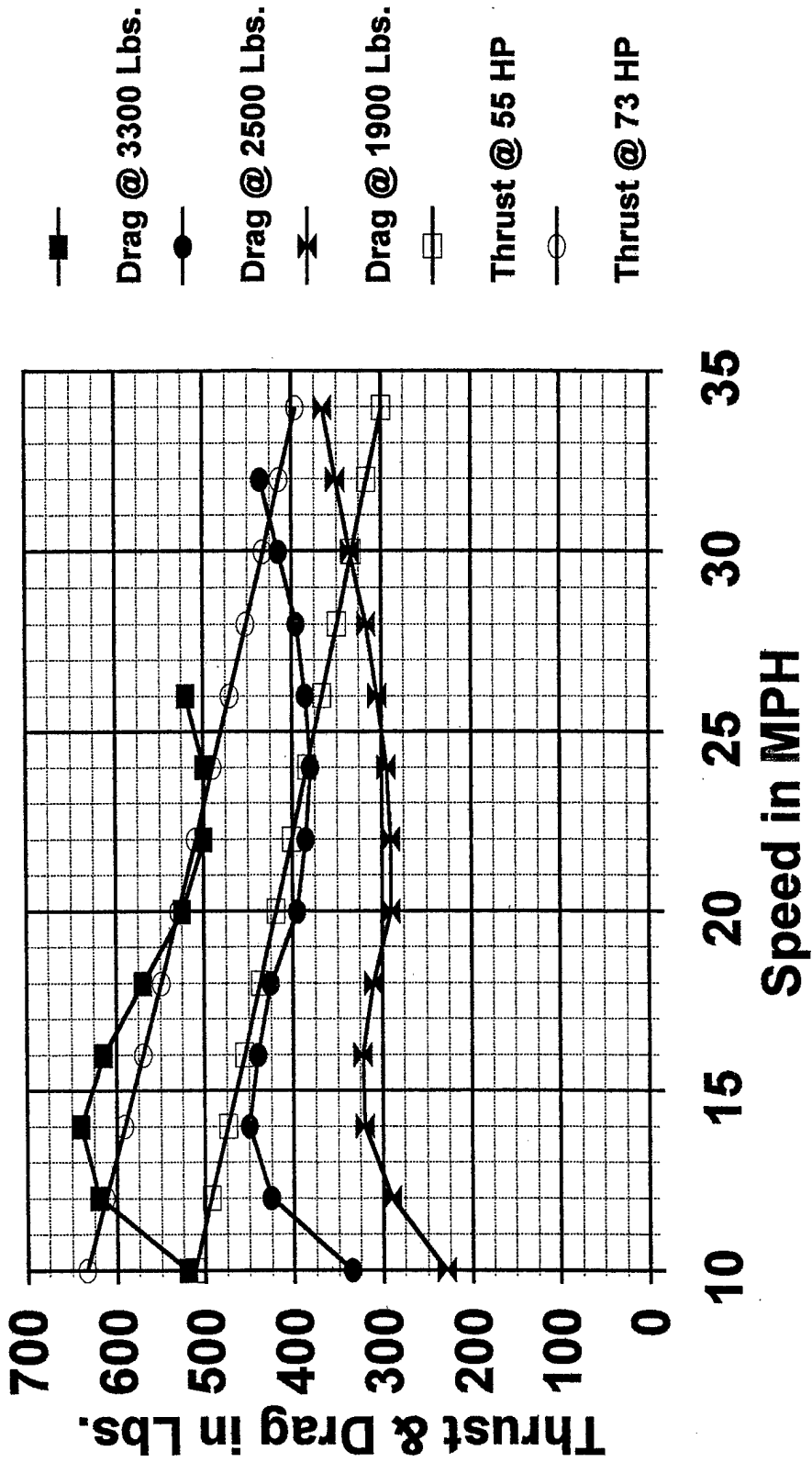

WEIGHT STUDY

Based on July 23, 1997 actual scale weights

ITEM	Weight, Lbs.	Use in OB Jet:	Weight, Lbs.	Correction For Size:
Grill & Elbow	23	yes	23	
Wear Ring	2	yes	2	
Stator	12	no	0	
Nozzle Ring	15	equals volute & nozzles	15	
Impeller	2	yes	2	
Ball Bearings	2	bushings = 1/2 ball brg.	1	Weight is proportional to diameter to the 2.5 power
Drive adaptor	3	no	0	
Drive Shaft	9	Belt & Pulley = 1/2 shaft	4.5	
Transom plate	8	Equals mounting	8	
Misc. Small parts	11	yes	11	
Misc. Hardware	3	yes	3	
		Add housing	3	New Size = 5.00
		Add rubber mounts	8	New Jet Weight = 32.4
		Add steering tiller	4	Engine (Scale Weight) = 85.0
			3	Exhaust System Wgt. = 10
7.34" I/O Jet Weight =	90	7.34" OB Jet Weight =	84.5	5.00" Outboard Total Lbs. = 127.4

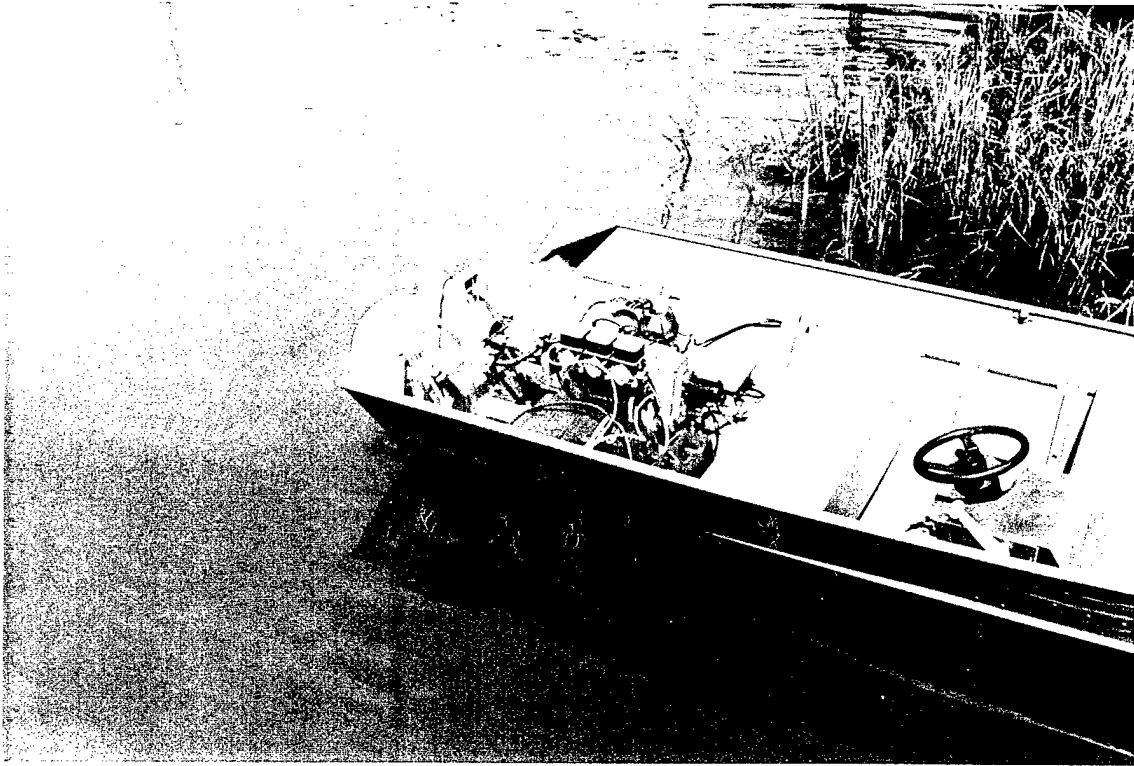

Demonstration Boat with engine cover removed

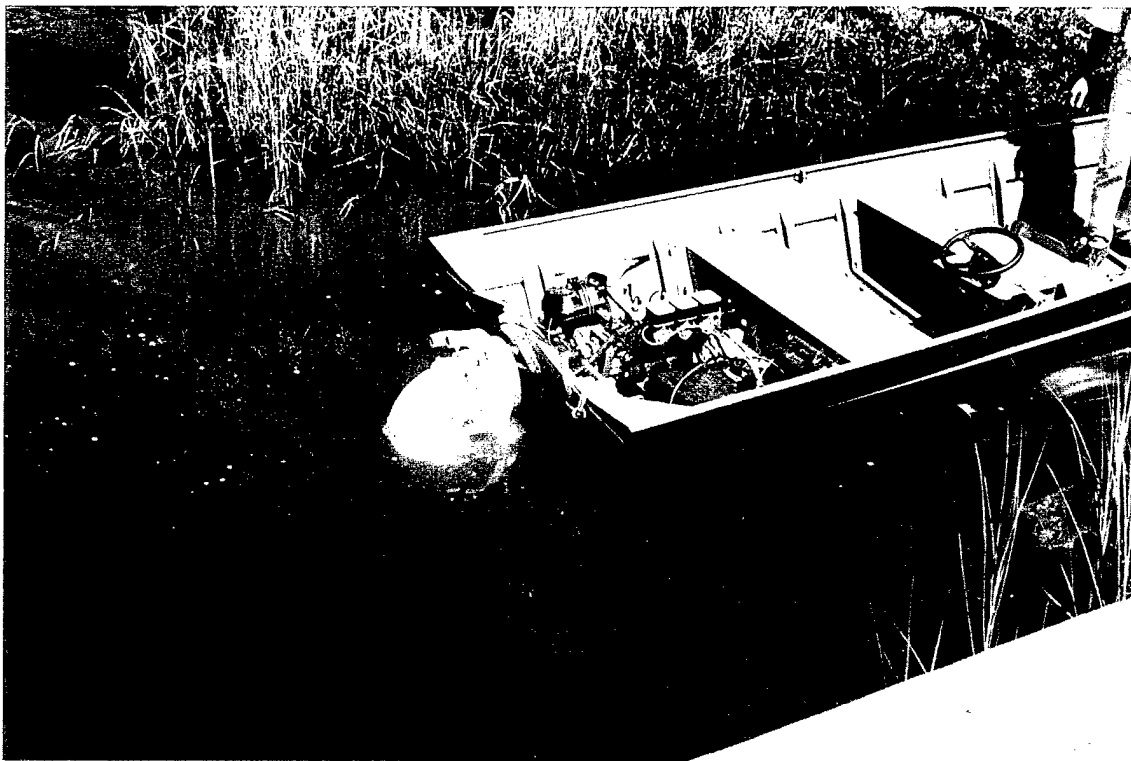

Demonstration Boat with engine cover removed

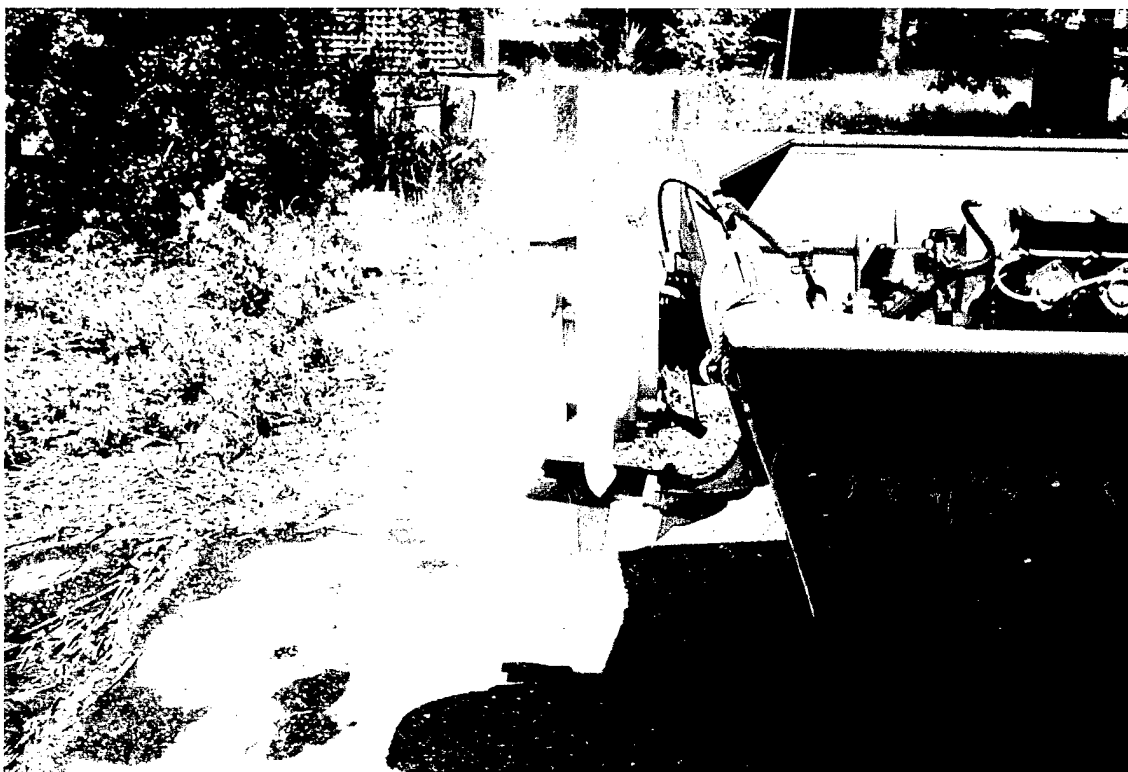

Demonstration Boat, side view of drive

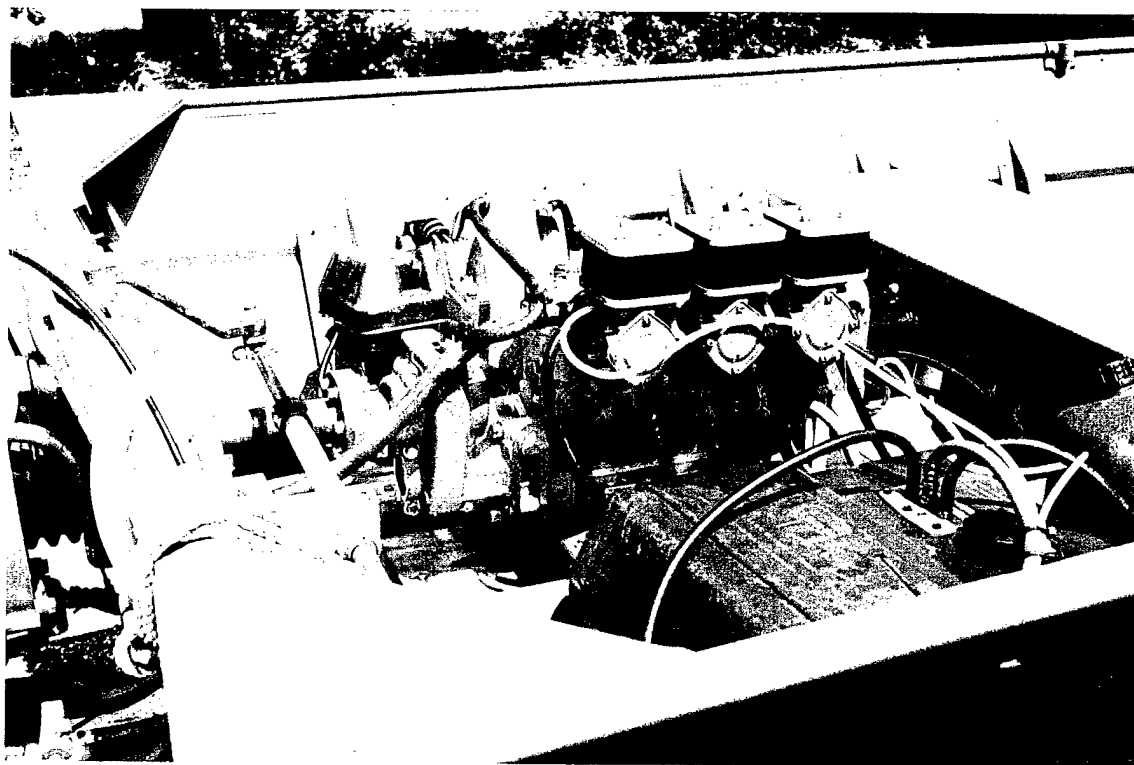

Demonstration Boat, engine installation showing drive shaft, reduction gear, steering control, fuel tank and battery



Demonstration Boat, finished installation with engine cover in place



Demonstration Boat in operation