

ARMY RESEARCH LABORATORY



# High-G Power Sources for U.S. Army's Hardened Subminiature Telemetry and Sensor Systems (HSTSS) Program

by L. W. Burke, Jr., E. S. Irwin,  
R. Faulstich, C. E. Newnham, and N. Scholey

ARL-MR-352

June 1997

DTIC QUALITY INSPECTED 4

19970929 030

Approved for public release; distribution is unlimited.

**The findings in this report are not to be construed as an official Department of the Army position unless so designated by other authorized documents.**

**Citation of manufacturer's or trade names does not constitute an official endorsement or approval of the use thereof.**

**Destroy this report when it is no longer need. Do not return it to the originator.**

# **Army Research Laboratory**

Aberdeen Proving Ground, MD 21005-5066

---

---

ARL-MR-352

June 1997

## **High-G Power Sources for U.S. Army's Hardened Subminiature Telemetry and Sensor Systems (HSTSS) Program**

L. W. Burke, Jr., E. S. Irwin  
Weapons and Materials Research Directorate, ARL

R. Faulstich  
U.S. Army Test and Evaluation Command, YPG

C. E. Newnham, N. Scholey  
Ultralife Batteries

---

---

## **Abstract**

---

Under the Hardened Subminiature Telemetry and Sensor Systems (HSTSS) program, the U.S. Army has been developing gun-hardened telemetry devices and subsystems for the testing of smart-weapon systems. These devices will be able to withstand accelerations in excess of 100,000 g and radial accelerations in excess of 25,000 g. Under this program, rechargeable lithium ion polymer battery technology and primary lithium manganese dioxide technology are being developed for ballistic telemetry applications. To date, prototypes of these batteries have survived accelerations well over 100,000 g. This report provides the current status of these developments and reviews the battery designs and testing regimes.

## ACKNOWLEDGMENTS

The authors would like to thank members of the electronics team, specifically, C. Mitchell, E. Ferguson, D. Hepner, J. Faust, P. Muller, and B. Davis, and M. Hollis of the Advanced Munitions Concept Branch, U.S. Army Research Laboratory, for their engineering and test support.

The authors would also like to acknowledge the contributions made by O. J. Gross and D. LeVey, Ultralife Batteries Inc., on the Li/MnO<sub>2</sub> "Thin Cell" and D. Davies and P. Bennett, Ultralife Batteries (UK) Ltd., on the high-rate Li/MnO<sub>2</sub> cell.

The U.S. Army Simulation Training and Instrumentation Command (STRICOM) Program Manager for Instrumentation, Targets, and Threat Simulators is recognized for its managerial support.

INTENTIONALLY LEFT BLANK.

## TABLE OF CONTENTS

	<u>Page</u>
ACKNOWLEDGMENTS .....	iii
LIST OF FIGURES .....	vii
LIST OF TABLES .....	ix
1. INTRODUCTION .....	1
2. BACKGROUND .....	1
2.1 Review of Previous Contract Work .....	3
2.2 Current Contract Status .....	3
3. RECHARGEABLE SOLID POLYMER LITHIUM ION .....	4
3.1 Technology Description .....	4
3.2 Review of Test Data .....	5
3.3 Shock Table Data .....	5
3.4 Airgun Data .....	7
3.5 Airgun Results .....	7
3.5.1 First-Round Results .....	7
3.5.2 Second-Round Results .....	10
3.6 Spin Data .....	11
3.7 Summary .....	11
4. LITHIUM ION MULTICELL DESIGNS .....	13
4.1 Nose-Fuse Application .....	13
4.2 Battery Design .....	14
4.3 Nose-Fuse Battery .....	15
5. PRIMARY Li/MnO <sub>2</sub> THIN CELL TECHNOLOGY .....	15
5.1 Technology Description .....	15
5.2 Shock and Spin Testing .....	18
5.3 Summary .....	18

	<u>Page</u>
6. HIGH-RATE CELLS .....	18
6.1 Technology Overview .....	18
6.2 Summary .....	19
7. CONCLUSIONS .....	21
8. REFERENCES .....	23
DISTRIBUTION LIST .....	25
REPORT DOCUMENTATION PAGE .....	29

## LIST OF FIGURES

<u>Figure</u>		<u>Page</u>
1.	Typical nickel cadmium battery responses during spin test .....	2
2.	Cross section of an Ultralife lithium ion polymer cell .....	4
3.	Lithium ion cell response vs. acceleration (3-mA load) .....	6
4.	Typical lithium ion cell responses vs. acceleration (3-mA load) .....	6
5.	Cell orientation for airgun testing .....	8
6.	Cell orientation with respect to spin axis .....	12
7.	Typical lithium ion cell responses vs. spin (10-mA load) .....	13
8.	Fuse-configured yawsonde measurement system .....	14
9.	Design of 16-V 120-mAh nose-fuse battery (dimensions in millimeters) .....	16
10.	Cycling performance of nose-fuse cell on 15-mA (C/8) discharge .....	16
11.	Power-rate curve of nose-fuse cell .....	17
12.	Discharge curve of nose-fuse cell on 150-mA (1.25 C) load .....	17
13.	Li/MnO <sub>2</sub> Thin Cell response vs. spin (10-mA load) .....	19
14.	High-rate Li/MnO <sub>2</sub> C-size cell response vs. spin (100-mA load) .....	20

INTENTIONALLY LEFT BLANK.

## LIST OF TABLES

<u>Table</u>	<u>Page</u>
1. Summary of Airgun Test No. 1 .....	9
2. Summary of Airgun Test No. 2 .....	10

INTENTIONALLY LEFT BLANK.

## 1. INTRODUCTION

The Hardened Subminiature Telemetry and Sensor System (HSTSS) program has been a technical effort involving the U.S. Army Research Laboratory (ARL) Weapons Technology Directorate (WTD) and the U.S. Army Test and Evaluation Command (TECOM), Yuma Proving Ground. This program is developing telemetry transmitters, antennas, programmable high-density multichip modules, physical sensors, programmable data-acquisition chip sets, and power sources for high-g applications [1]. The goal of the program is to provide low-cost, user-configurable telemetry components for making in-flight measurements of smart weapon systems. These new telemetry components are being developed to withstand shock levels in excess of 100,000 g and radial accelerations in excess of 25,000 g.

This report focuses on the battery development effort with Ultralife Batteries (UK) Ltd. Under a current U.S. Army contract, Ultralife will be providing both primary and secondary batteries for evaluation in ballistic applications. This paper provides the current status of these developments and reviews battery designs, test regimes, and results.

## 2. BACKGROUND

An on-board telemetry power source usually consists of several cells connected together to give the desired voltage and capacity. Typically, these can be primary (i.e., lithium), secondary (i.e., nickel cadmium), or reserve batteries. These batteries are of fixed dimension and often large when compared to other telemetry components. Because these batteries are rigid, the designer has very little flexibility in the package design. If moments of inertia and center of gravity of the flight body are to be preserved, the job becomes even more challenging. In the past, special order batteries that would meet these requirements have proved to be cost-prohibitive.

Safety and performance issues have also been of concern. For example, many types of nickel cadmium cells degrade in performance when subjected to high spin rates. Figure 1 shows this

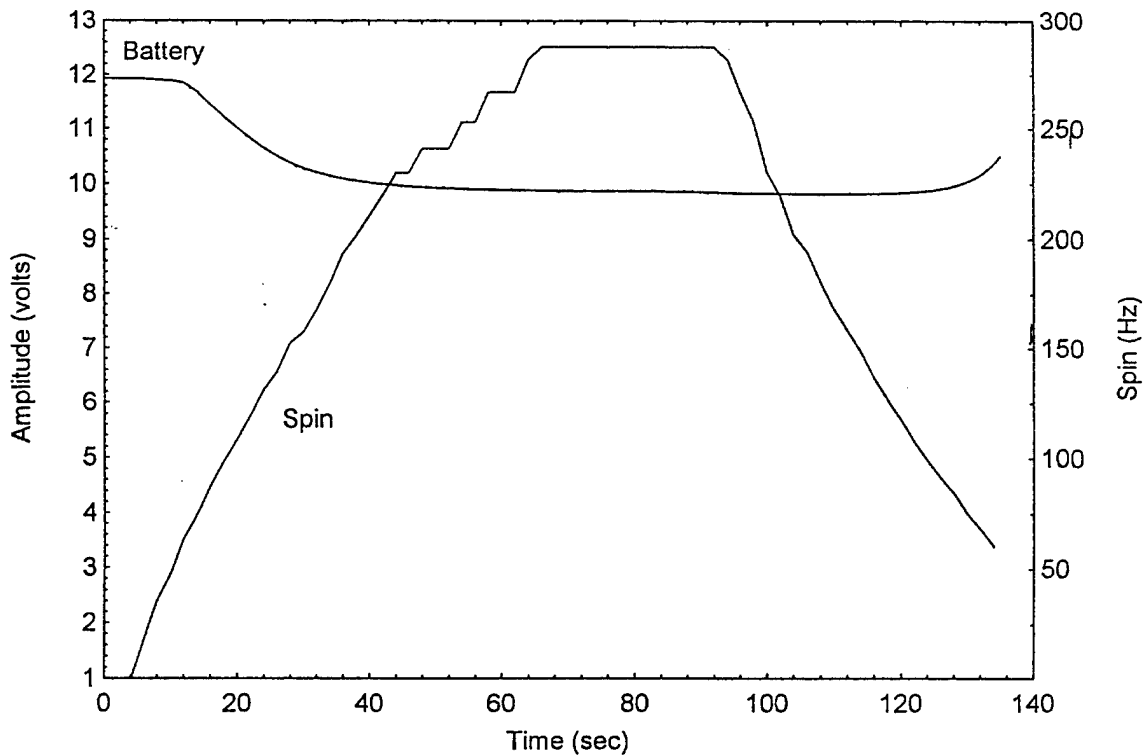

Figure 1. Typical nickel cadmium battery responses during spin test.

typical behavior. Depending on the cells internal structure, this problem may escalate when mounted either on or off the spin axis. Due to design constraints, the power source is often embedded in the projectile and is not removable. In these cases, a rechargeable supply is preferred. Typically, before the projectile is launched, it is put through a series of ground tests that allow for the calibration of sensors and electronics. When the calibration procedures require a spinning platform and nickel cadmium batteries are used, the number of calibration cycles that should be performed is limited.

Under the HSTSS program, conformal solid polymer electrolyte and conformal Li/MnO<sub>2</sub> batteries are being developed by Ultralife Batteries (UK) Ltd., for high-g applications. This technology is being proposed for telemetry applications where power requirements are not extreme, but where space and packaging is of major concern. It is expected that these technologies will provide the telemetry engineer with an affordable and reliable power source, while allowing more flexibility in the system package design.

2.1 Review of Previous Contract Work. To date, three separate battery development contracts have been conducted under the HSTSS program. The first contract was with Dowty Batteries (now Ultralife Batteries (UK) Ltd.) for the evaluation and modification of rechargeable Li/V<sub>6</sub>O<sub>13</sub> polymer electrolyte cells. This took place in 1994, and primarily focused on the survivability issues of the cell structure under high accelerations. This evaluation showed that the basic cell structure could be modified to survive accelerations of 80,000 g and radial accelerations of 4,300 g. Details of this work can be found in Burke, Faust, and Mitchell [2] and Burke, Faulstich, and Newnham [3].

In 1995, a second contract was initiated with Ultralife Batteries (UK) Ltd., to conduct a study on rechargeable lithium ion solid polymer cells. After making several modifications to the cell structure, it was shown that these cells could survive accelerations of over 100,000 g and radial accelerations over 25,000 g. The lithium ion chemistry offers a much better practical energy density (>100 Wh kg<sup>-1</sup>) and a higher operating voltage (3.6 V) than does the Li/V<sub>6</sub>O<sub>13</sub> chemistry. During this study, Ultralife's Primary Li/MnO<sub>2</sub> "Thin Cell" and high-rate cylindrical cells were also evaluated for ballistic applications. Both technologies have applications in high-g telemetry and projectile guidance and control systems, and both yielded promising results during these preliminary tests.

2.2 Current Contract Status. Currently, the HSTSS program has Ultralife Batteries (UK) Ltd., under a 12-mo, three-part contract to provide batteries for ballistic telemetry applications. This three-part contract addresses (1) solid polymer lithium ion technology, (2) primary Li/MnO<sub>2</sub> Thin Cell technology, and (3) primary Li/MnO<sub>2</sub> high-rate technology. The goals of this contract are as follows:

- Finalize cell structure for high-g survivability.
- Develop assembly and fabrication techniques for multicell batteries.
- Deliver multicell batteries for typical munitions test applications.

The remainder of this report focuses primarily on the lithium ion effort and reviews cell design and specifications, test results, and special application designs. Work being performed on primary Thin Cells and high-rate cells is also discussed.

### 3. RECHARGEABLE SOLID POLYMER LITHIUM ION

3.1 Technology Description. This rechargeable technology comprises a carbon anode coupled with a lithiated manganese oxide ( $\text{LiMn}_2\text{O}_4$ ) cathode. In place of a conventional liquid electrolyte is a polymer that functions both as a transporting medium for the lithium ions and an electronic insulator that prevents the electrodes from shorting. By incorporating a lithium salt and organic plasticisers into the polymer matrix, high ionic conductivity, good electrochemical stability, and high mechanical strength have been obtained. A basic diagram of the cells structure is shown in Figure 2.

The batteries are fabricated by laminating the electrode and electrolyte layers with the proper use of heat and pressure. This assembly is contained within a foil laminating package sealed by conventional heat-bonding methods.

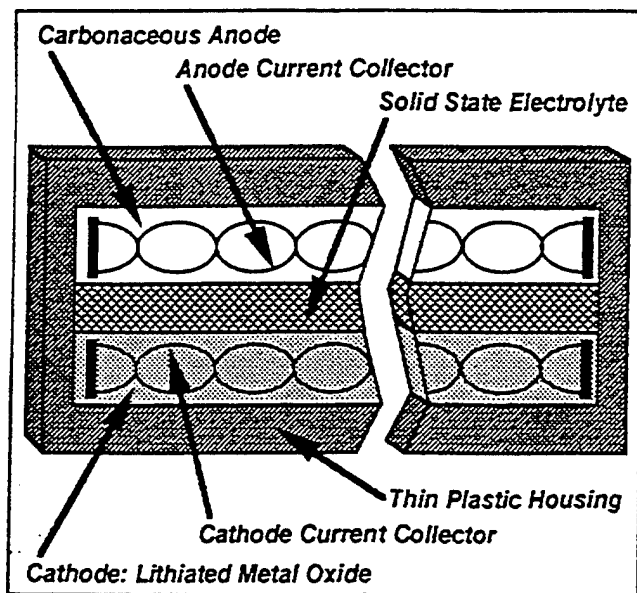

Figure 2. Cross section of an Ultralife lithium ion polymer cell.

The polymer battery is configurable in a variety of thin prismatic shapes and possesses high energy density (>100 Wh/Kg) and excellent cyclability (>500 cycles to 80% of initial capacity). It is capable of being charged in less than 2.5 hr and can be discharged continuously at rates up to 2 C. As a result of using a polymer electrolyte and the absence of lithium metal, the cells are extremely abuse-tolerant when subjected to short circuit, overcharge, and forced-discharge conditions.

3.2 Review of Test Data. The following is a review of test data gathered thus far on the solid-state lithium ion cells (contracts 2 and 3). The tests conducted were very similar to those performed under the first contract, which evaluated the lithium vanadium oxide cell. Details, diagrams, and photographs of all test apparatus can be found in Burke, Faulstich, and Newnham [3].

The cells provided by Ultralife for shock and spin testing were of a flat rectangular format and measured approximately 46 mm by 36 mm and had a capacity of 20 mAh.

3.3 Shock Table Data. An impact shock test machine is used to establish cell behavior for shock levels of 30,000 g or less. The batteries are typically tested in two different orientations: (1) mounted with the thin edge along the shock vector (vertically) and (2) mounted with the thin edge perpendicular to the shock vector (horizontally). The cells are sprayed with mold release, placed into an aluminum test fixture, and encapsulated on all sides. This procedure allows the encapsulated cell to be removed so that a physical inspection of the cells internal components can be performed after the tests. The cells are shock-tested under a resistive load and monitored throughout the shock event. An accelerometer, which is mounted to the drop table, is also monitored. Typical data plots can be seen in Figures 3 and 4.

Numerous cells were tested using this apparatus during the early stages of development. The first step was to shock-test the standard commercial cell so that failure mechanisms could be identified and corrected. Figure 3 shows cell voltage dropping out during and just after shock.

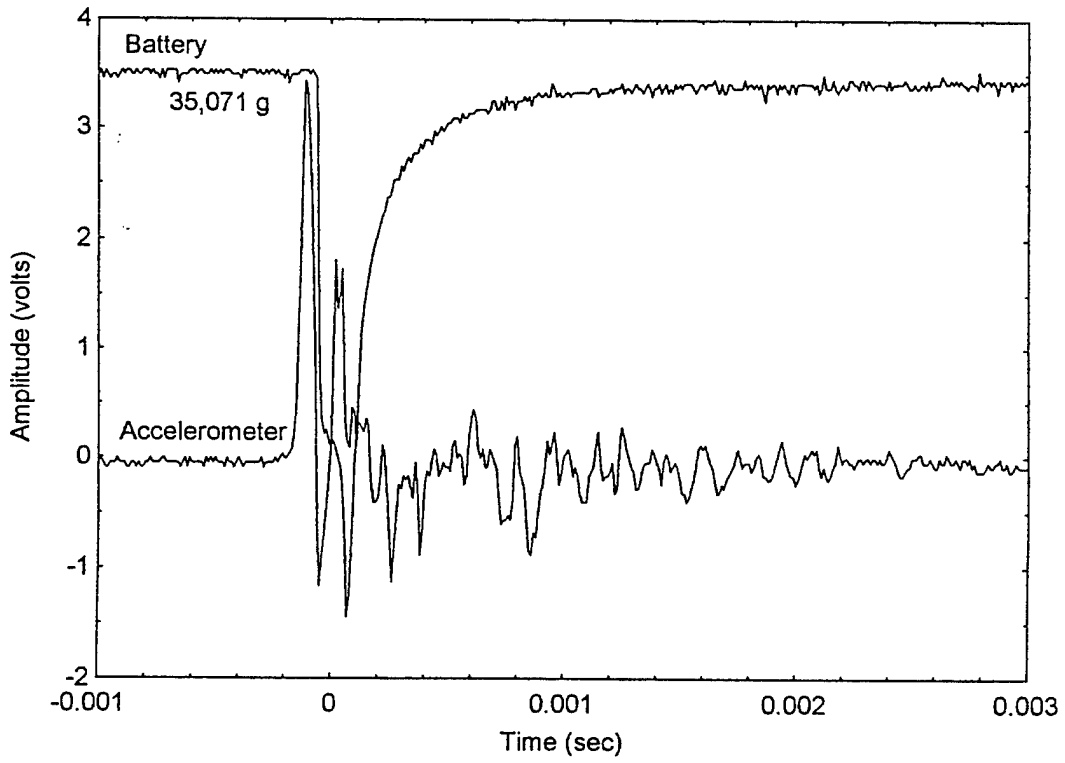

Figure 3. Lithium ion cell response vs. acceleration (3-mA load).

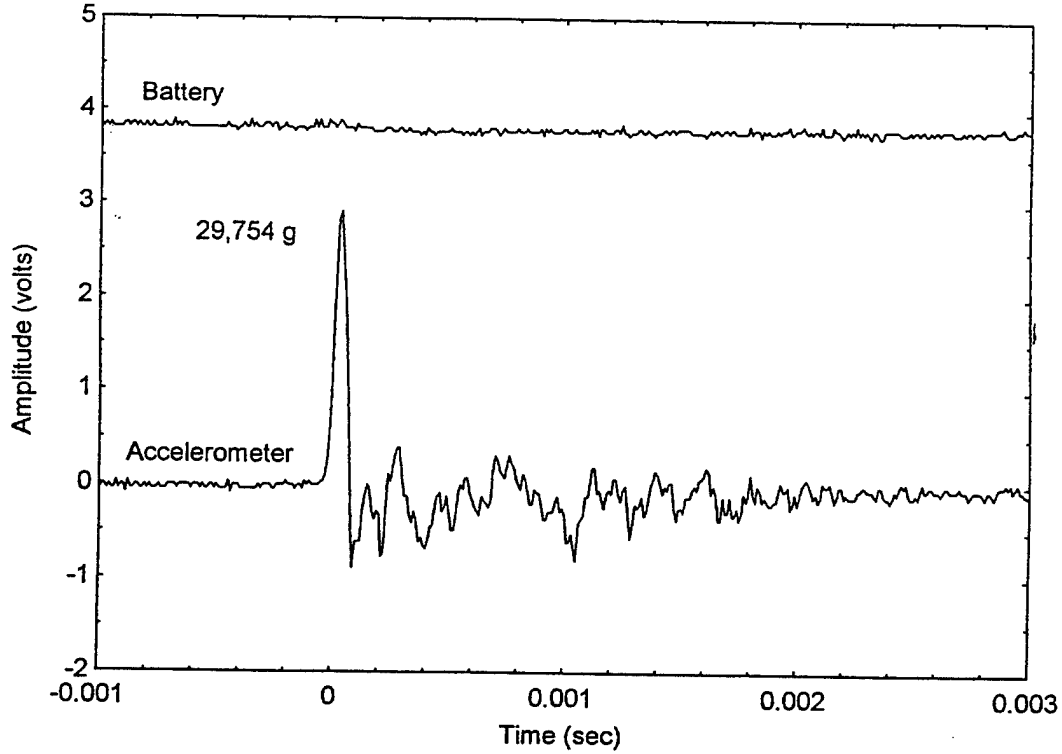

Figure 4. Typical lithium ion cell responses vs. acceleration (3-mA load).

Post-analysis of these cells revealed the failure mode was both due to the tag welds and tag material strength [4, 5].

After switching to ultrasonic welds and changing the tag material, the lithium ion cells routinely survived accelerations of 30,000 g in both the horizontal and vertical positions. Figure 4 shows an ideal data plot.

3.4 Airgun Data. In order to qualify the cells at much higher acceleration levels, a high-pressure airgun is used. Test items are fitted into a carrier body and launched by the airgun. After exiting the tube, the carrier impacts a mitigator and momentum exchange mass designed specifically to create a unique deceleration profile. A complete description of this apparatus and its operation can be found in Burke, Faulstich, and Newnham [3] and Davis et al. [6].

A typical test regime consists of seven shots, starting at 40,000 g (nominal) and progressing to 100,000 g (nominal) in increments of 10,000 g. Each test includes two cells, one mounted vertically and one mounted horizontally with respect to the shock vector (Figure 5). The cells are treated with mold release, placed into an oversized mold, and encapsulated [6]. The molded styrene cast is then machined down to fit snugly into the carrier. Wires that are attached to each cell terminal are also machined flush with the potting and provide a means for testing or charging the cells. The cells cannot be electrically loaded or monitored during impact. Each cell's open circuit voltage (OCV) is measured and recorded before and after each test. The encapsulated cells are then returned to Ultralife where post-test analysis is performed.

3.5 Airgun Results. To date, two rounds of airgun tests have been performed on the lithium ion cells. The first round of tests occurred in October of 1995, and the second in July 1996. In both cases, decelerations greater than 100,000 g were achieved.

3.5.1 First-Round Results. The cells that were positioned horizontally survived all the tests. The large variation in the OCV was related to the quality of the seal of the foil packaging, which led to the premature discharge of several cells. New sealing procedures have since corrected this

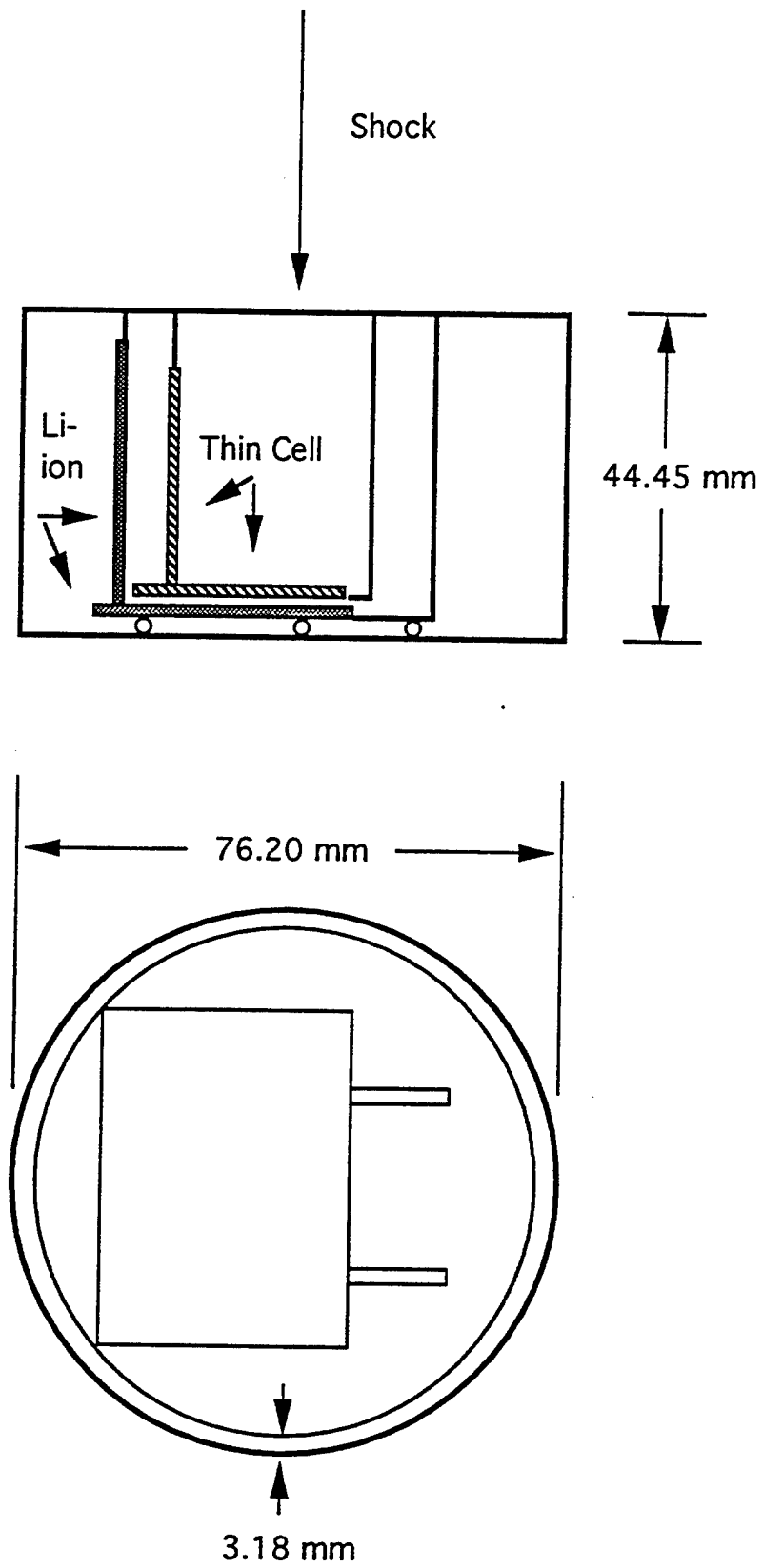

Figure 5. Cell orientation for airgun testing.

problem. Ultralife's Investigation Report No. 3 clearly shows there was no deformation of these cells, even at 115,000 g [7].

The cells positioned vertically did not fare as well. Table 1 shows that the only cell to survive the airgun test was at 51,000 g. Examination of the cells at Ultralife showed a common mode of failure, this being detachment of electrodes from the tags [7]. However, this appeared to have been caused by swelling of the cell package that resulted in insufficient support for the electrodes. Further investigation revealed that the potting procedure inadvertently led to encapsulant curing temperatures in excess of 150° C, and that this was responsible for the unexpected behavior on the airgun tests. It is interesting to note that the majority of the cells retained their charge even after being subjected to a temperature of more than twice their maximum rating for several minutes.

Table 1. Summary of Airgun Test No. 1

Trial Number	Target Acceleration (g × 1,000)	Measured Acceleration (g × 1,000)	(OCV) <sup>a</sup> Before Shock (horz./vert.)	(OCV) After Shock (horz./vert.)
1	40	49	3.26/0.42	3.26/0.00
2	50	51	1.24/1.77	1.24/2.04
3	60	58	3.89/3.64	3.89/0.00
4	70	70	3.79/3.69	3.78/0.00
5	80	80	3.68/1.03	3.68/0.00
6	90	95	0.99/0.61	0.99/0.61
7	100	115	3.89/3.54	3.89/0.00

<sup>a</sup> Low OVCs due to encapsulant curing temperature > 150° C and seal quality.

From these data it appears the lithium ion polymer cells, when mounted in a vertical position and fully supported, are able to survive at least 50,000 g. When mounted in the horizontal position, they are capable of over 100,000 g.

3.5.2 Second-Round Results. A second round of airgun tests was performed in July of 1996. The test regime was very similar to that just discussed. The cells used for testing were also of the same type with modifications made to the structure and packaging. Vertical cells were present in all five trials. Horizontally positioned cells were not tested in the range of 60,000–80,000-g test trials. The results are summarized in Table 2.

Table 2. Summary of Airgun Test No. 2

Trial Number	Target Acceleration (g × 1,000)	Measured Acceleration (g × 1,000)	(OCV) Before Shock (horz./vert.)	(OCV) After Shock (horz./vert.)
1	60	65	N/A/3.99	N/A/0.00
2	70	75	N/A/3.98	N/A/3.97
3	80	89	N/A/4.00	N/A/3.99
4	90	93	3.98/4.03	3.99/4.04
5	100	110	4.00/4.00	4.02/3.98

With the exception of the cell tested at 60,000 g in the vertical plane, all cells survived the shock testing. The cells tested at 60,000; 100,000; and 110,000 g were sent to Ultralife for further inspection.

The cause of failure for the cell tested at 60,000 g was subsequently shown to be due to the shearing of the anode tag at the boundary of the anode current collector. It is likely that this was the result of damage to the tag during assembly. There was, however, no evidence of the tag welds failing on either the anode or cathode [8].

Although the OCV readings indicated cell survivability at acceleration levels greater than 100,000 g, further examination of the cells revealed some minor deformation. This is attributable to the edge of the cell not being in complete contact with the seal of the packaging. A simple modification to the package design would easily eliminate this problem [8].

Overall, these results were extremely encouraging and showed that the cells could indeed survive shocks in excess of 100,000 g in both orientations.

3.6 Spin Data. The purpose of these tests was to evaluate the electrical performance of the cell when subjected to typical artillery projectile spin rates (up to 300 Hz). The cells tested are of the same type as discussed previously in the technology description.

The apparatus used to conduct these tests is a three-degrees-of-freedom flight simulator manufactured by the Carco Corporation. This unique piece of equipment is capable of rotating a 45 kg 155-mm projectile up to 300 Hz while inducing yaw motion up to 20 Hz. Typically, a set of four batteries is tested under load in the configuration as shown in Figure 6. A complete description of the test procedure can be found in Burke, Faulstich, and Newnham [3].

To date, over 25 single-cell configurations have been spin-tested in both orientations at rates greater than 300 Hz, yielding radial accelerations of more than 24,000 g. No failures have yet been seen, with only minor disturbances occurring that were attributed to the quality of the sealing. Typical spin data are shown in Figure 7.

3.7 Summary. As a result of the previously mentioned tests, a solid polymer lithium ion cell that can reliably perform at extreme accelerations is now available. The modifications made to the standard lithium ion polymer electrolyte construction to produce cells capable of surviving high-shock and spin levels are as follows:

- Tag location.
- Tag material change to improve tag-to-grid weld.
- Ultrasonic welding of tag to grid.
- Improved heat-sealing location around perimeter of cell.

Only mechanical changes were needed to the original polymer design as the cell chemistry was suitable for high-g applications.

Top View

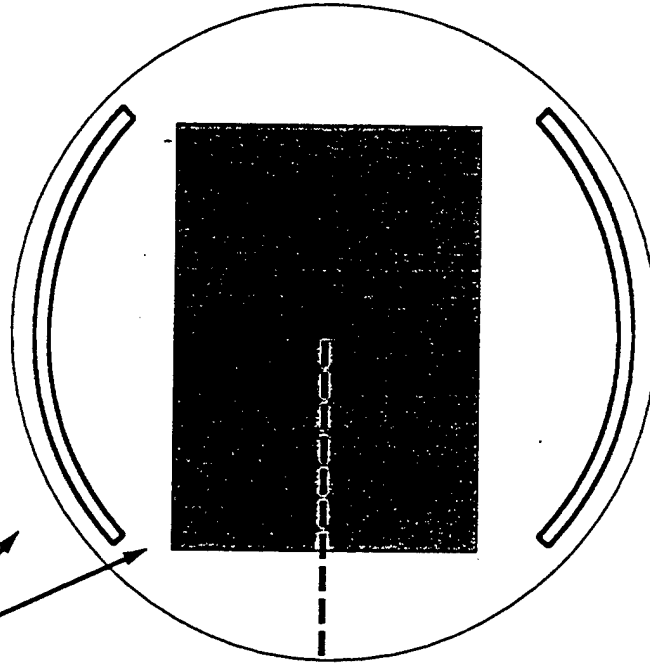

Lithium Ion  
cell

Side View

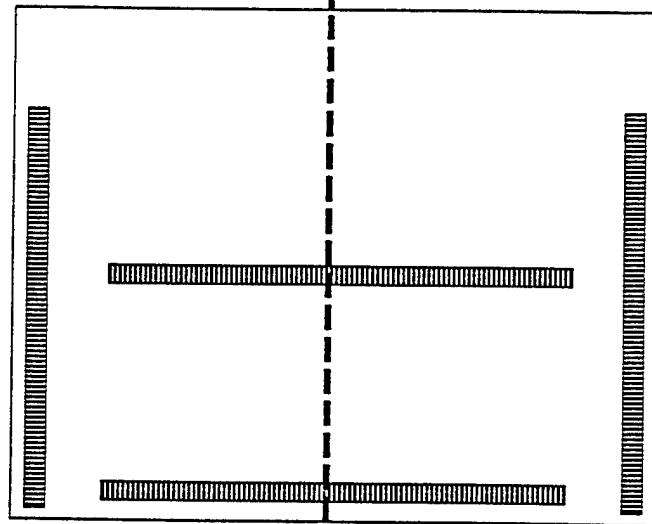

Spin Axis

Figure 6. Cell orientation with respect to spin axis.

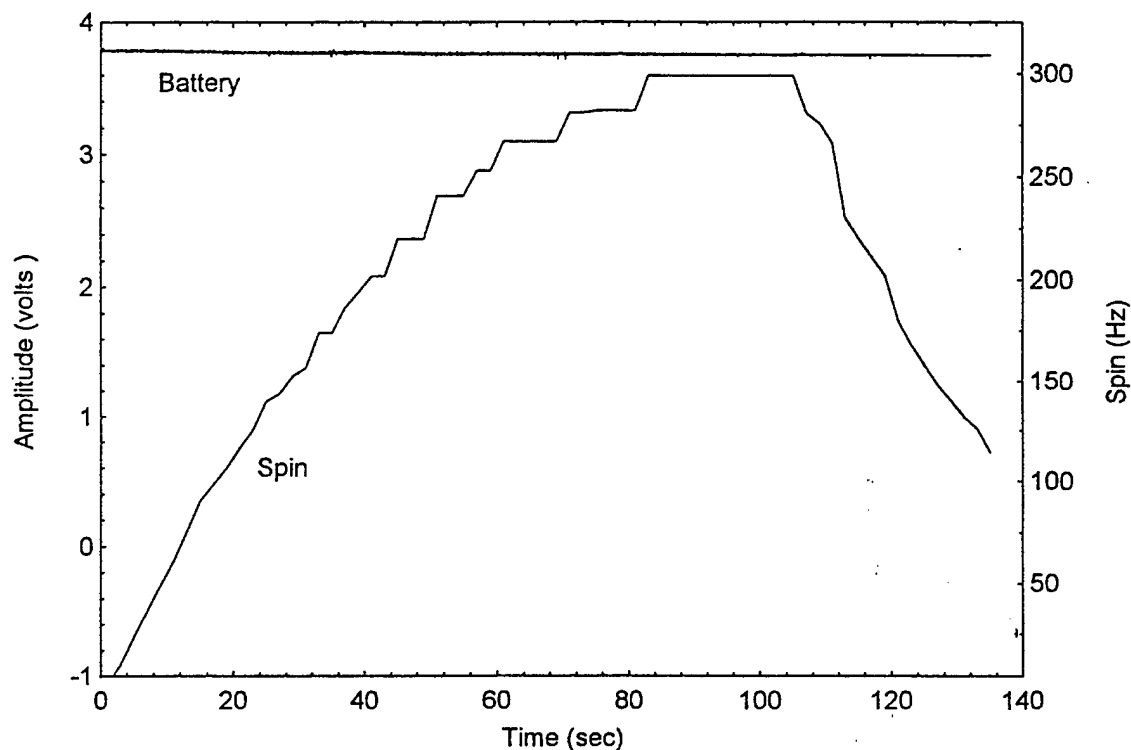

Figure 7. Typical lithium ion cell responses vs. spin (10-mA load).

#### 4. LITHIUM ION MULTICELL DESIGNS

The next step in the program is to build multicell battery packs using the knowledge gained from the previous tests. Under the current HSTSS contract, Ultralife will be building two battery packs for flight instrumentation applications. The first will be for an artillery nose-fuse configuration and the other for a Navy rocket configuration. At the time of writing, the rocket configuration had not yet been defined; therefore, only the nose-fuse application is discussed in this report.

4.1 Nose-Fuse Application. Figure 8 shows a diagram of a typical instrumentation package called a "yawsonde," which is routinely used by ARL for measuring the flight dynamics of a projectile. This telemetry package routinely includes sensors, such as photo diodes,

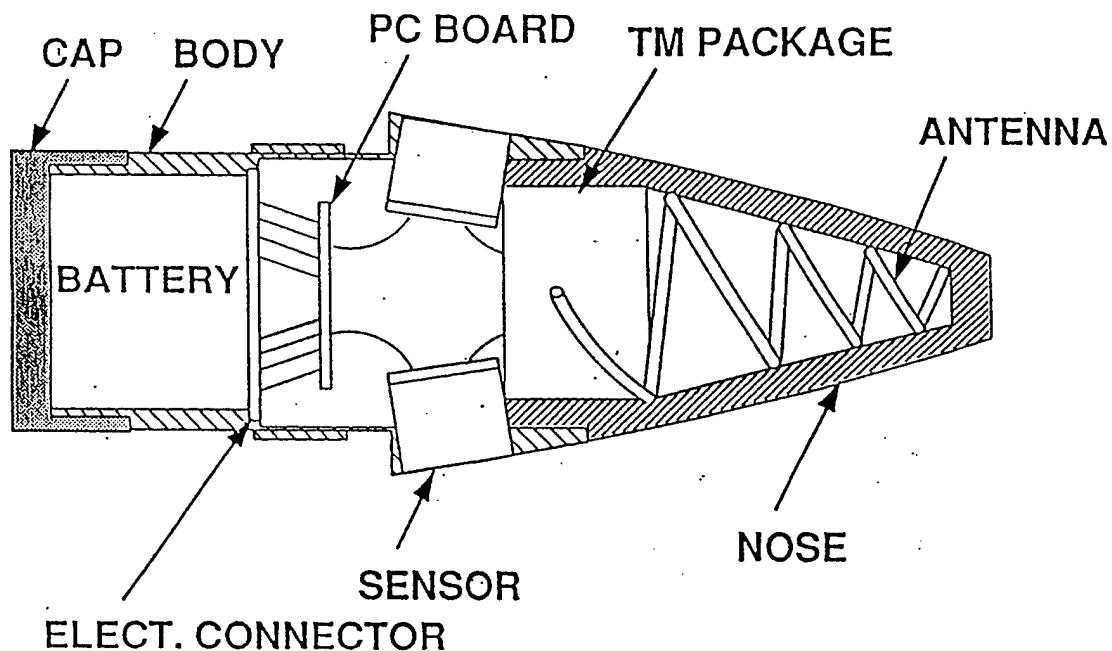

Figure 8. Fuse-configured yawsonde measurement system.

accelerometers, an angular rate sensor, and supporting electronics. The battery requirements for this instrumentation package are outlined in the following paragraphs.

The available envelope for this power source is a cylinder of 37-mm diameter and 33-mm length. After making an allowance for encapsulation, this is reduced to 32-mm diameter and 28.5-mm length.

The salient features of the battery specification are that it should deliver a current of 150 mA for 30 min to an end-point voltage of 12.3 V. The battery is mounted in a horizontal orientation and, while operational, should survive accelerations in the range 25,000–30,000 g and spin rates up to 300 Hz.

4.2 Battery Design. The rechargeable lithium ion polymer electrolyte power source used in this application is the same as that discussed in the technology description section.

4.3 Nose-Fuse Battery. In order to meet the specification, four lithium ion cells need to be connected in the series arrangement shown in Figure 9. Each cell has a nominal capacity of 120 mAh. This is achieved by the parallel stacking of disks using a novel design that minimizes the number of interconnections and prevents movement of the electrode assembly within the housing. Such an arrangement ensures the survivability of the battery at high-g forces and spin rates.

To date, individual 4-V, 120-mAh cells have been fabricated and tested against the requirement specification. Figure 10 shows the capacity of a typical cell to be used in the nose fuse battery. Over the period of interest (maximum five cycles) in the region of 130 mAh is obtained on a 15-mA (C/8) discharge.

Figure 11 is the power-rate curve for a typical 4-V cell. This provides information on the rate capability of the cell and shows that at a current of 150 mA of the order of 63% of the cell capacity is available viz. 80 mAh. This is equivalent to an operational time in excess of 30 min, the design goal. Figure 12 depicts the discharge curve of a nose-fuse cell under a 150-mA load.

Work is in progress to fabricate 16-V, 120-mAh batteries in order to characterize the electrical performance. Shock, spin, and flight testing will also be performed to confirm the ruggedness of the design.

## 5. PRIMARY Li/MnO<sub>2</sub> THIN CELL TECHNOLOGY

5.1 Technology Description. Ultralife has developed a 3-V primary Li/MnO<sub>2</sub> cell in a flat format trademarked with the name Thin Cell. This cell design, which is housed in a foil laminate package, allows extremely efficient filling of battery cavities. Cells possess high energy density (>200 Wh Kg<sup>-1</sup>) and can operate over the temperature range -20° C to +50° C.

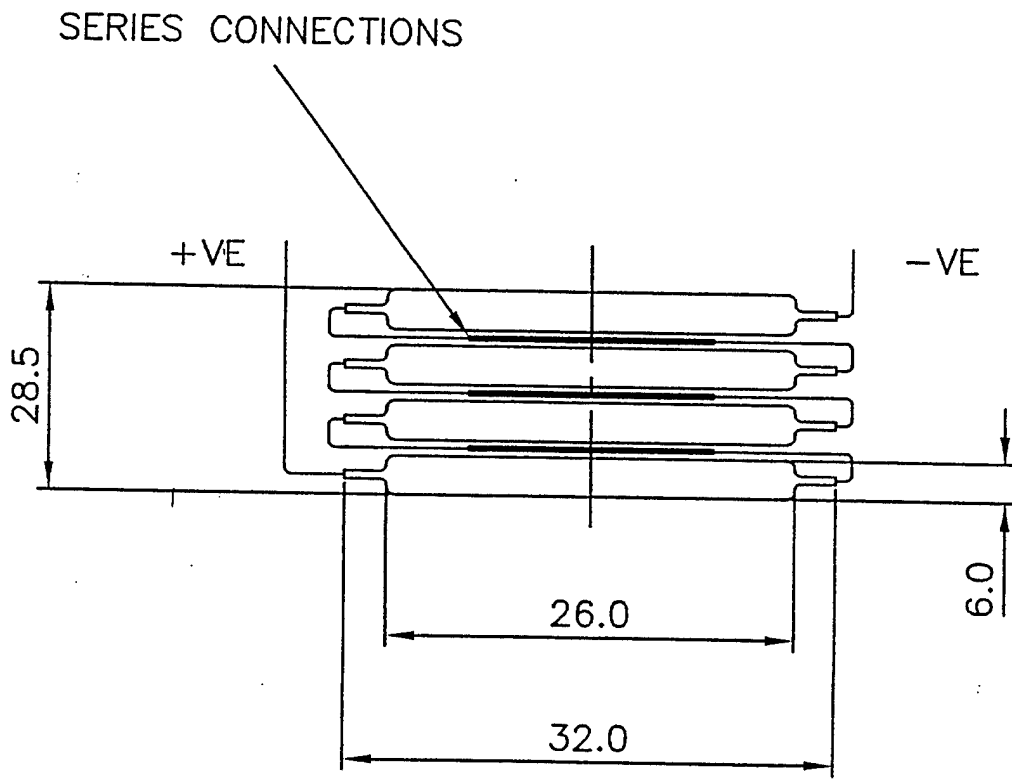

Figure 9. Design of 16-V 120-mAh nose-fuse battery (dimensions in millimeters).

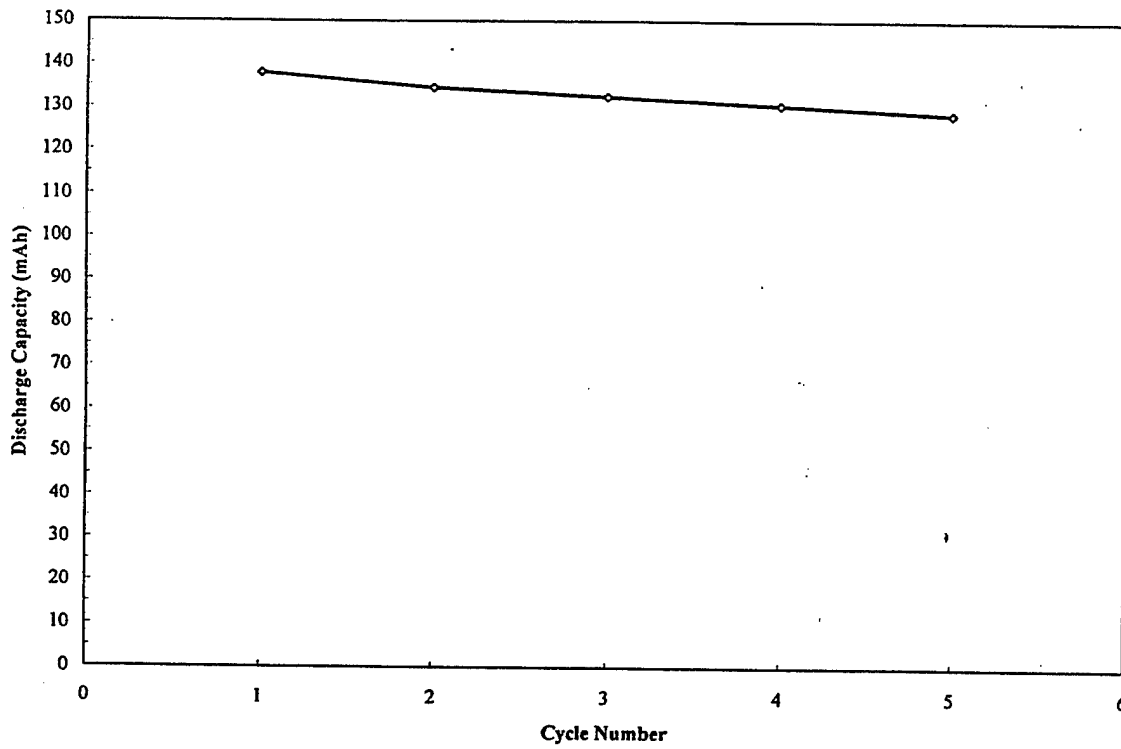

Figure 10. Cycling performance of nose-fuse cell on 15-mA (C/8) discharge.

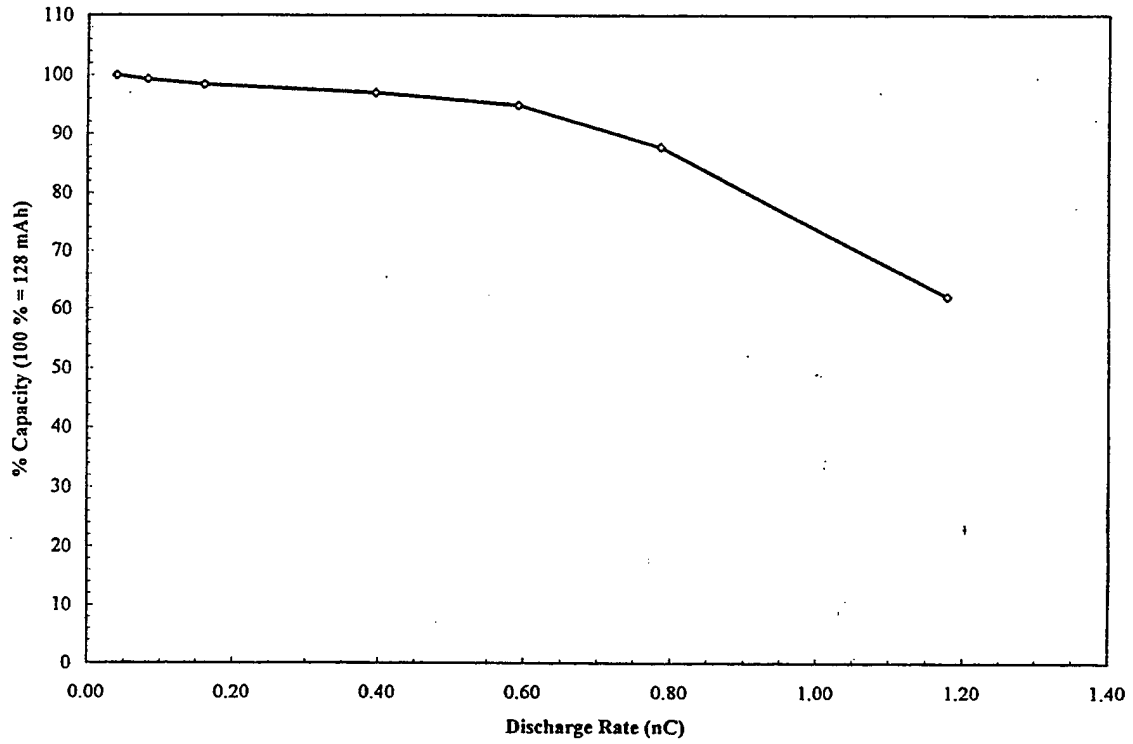

Figure 11. Power-rate curve of nose-fuse cell.

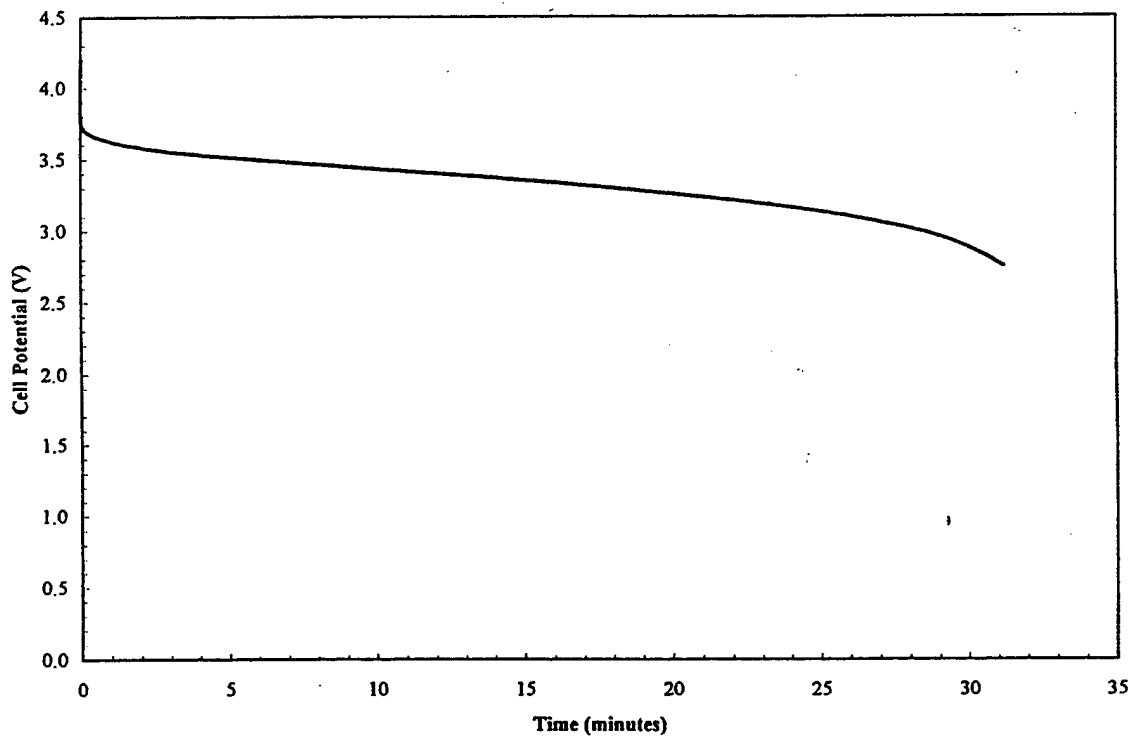

Figure 12. Discharge curve of nose-fuse cell on 150-mA (1.25 C) load.

This battery technology is being evaluated for applications not requiring rechargability, but needing a greater energy density and packaging flexibility than existing primary batteries. As with the lithium ion technology, the cells can be layered together to form a multicell pack and can also be preshaped to fit into unique cavities at a lower cost than other technologies. The Thin Cell technology is also being developed to survive accelerations of 100,000 g and radial accelerations of 25,000 g. Multicell designs will also be delivered for unique Army applications.

5.2 Shock and Spin Testing. To date, shock table, airgun, and spin testing have been performed only on the standard commercial cells. These tests were performed to determine any failure mechanisms of the basic cell structure.

With no structural modifications yet made to the cells, preliminary shock-table and airgun tests indicate that the cells are capable of surviving 110,000 g when mounted horizontally, but no more than 20,000 g (reliably) when mounted vertically. Preliminary spin testing shows that the cells perform well at spin rates up to 300 Hz. Figure 13 shows the response of a Thin Cell while under loading conditions. Post-analysis of these cells is currently underway.

5.3 Summary. Although preliminary data are promising, further work is required to modify the Thin Cell structure to ensure consistency in surviving high-g shocks [9]. Improvements, much like those outlined for the solid polymer lithium ion cells, are currently being considered.

## 6. HIGH-RATE CELLS

6.1 Technology Overview. Ultralife's high-rate primary Li/MnO<sub>2</sub> cells employ a spirally wound solid cathode construction that maximizes electrode surface area, generates low internal resistance, and enables a high discharge rate capability over a wide temperature range. This construction is housed in a hermetically sealed stainless steel container.

Unlike liquid cathode systems, the use of a manganese dioxide cathode ensures the absence of voltage delay following periods of storage. Furthermore, benign behavior under a range of

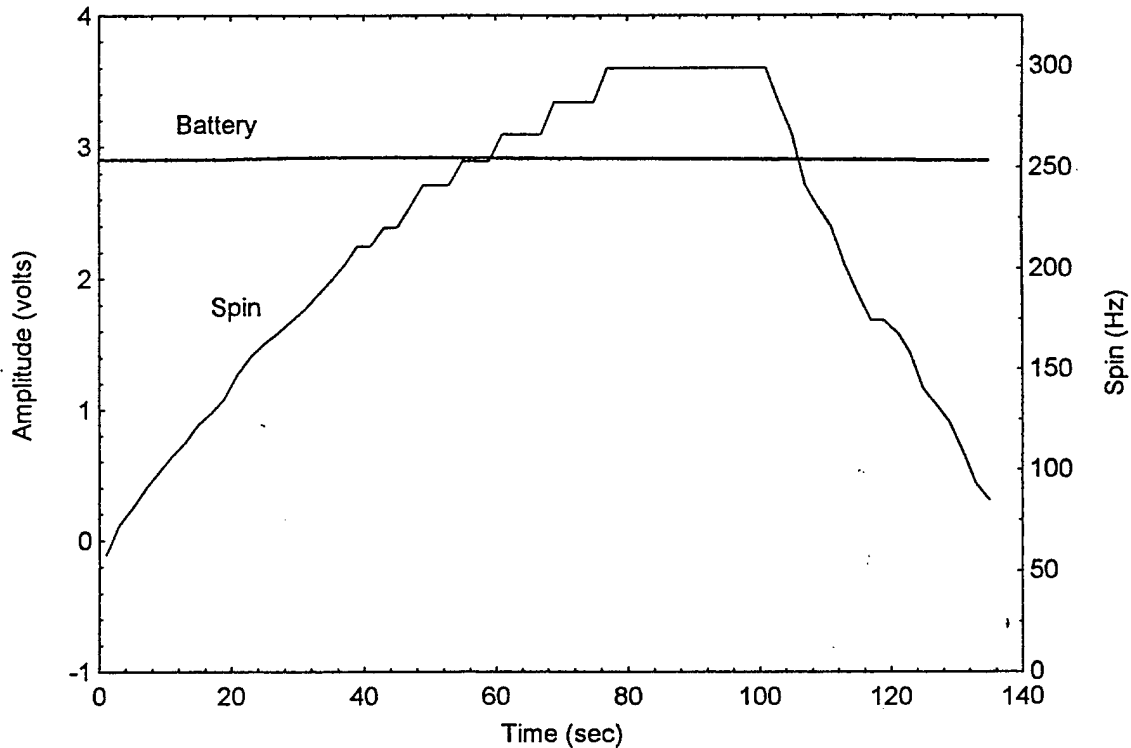

Figure 13. Li/MnO<sub>2</sub> Thin Cell response vs. spin (10-mA load).

abusive conditions is achieved by the unique cell design that includes a low-pressure vent and a copper anode current collector.

Ultralife's high-rate Li/MnO<sub>2</sub> batteries are being modified for lower shock applications where military operating temperatures and high current pulsing are required. Although these batteries do not offer the packaging flexibility of the solid polymer lithium ion or Thin Cell formats, they do yield an excellent energy density of better than 200 Wh Kg<sup>-1</sup>. Under the HSTSS program, these batteries will be modified to function during shock levels of 30,000 g and radial accelerations of more than 25,000 g. It is expected that these batteries will provide alternatives to more volatile battery chemistries, such as thionyl chloride and sulfur dioxide.

**6.2 Summary.** At the time of writing, the high-rate cell phase of this contract had just been initiated. To date, only preliminary shock table and spin testing have been performed on the standard commercial C-size high-rate cells.

It was observed from preliminary shock testing of high-rate cylindrical Li/MnO<sub>2</sub> cells that under certain conditions, bulging and occasional rupture of the vent cap occurred at shock levels above 5,000 g. A contributing cause of this was considered to result from small movements of the coil pack. Although not consistent, venting of the cells also occurred when subjected to radial accelerations greater than 10,000 g. It should be noted, however, that even after multiple spins, the cells maintained potential while under load. Figure 14 shows these data.

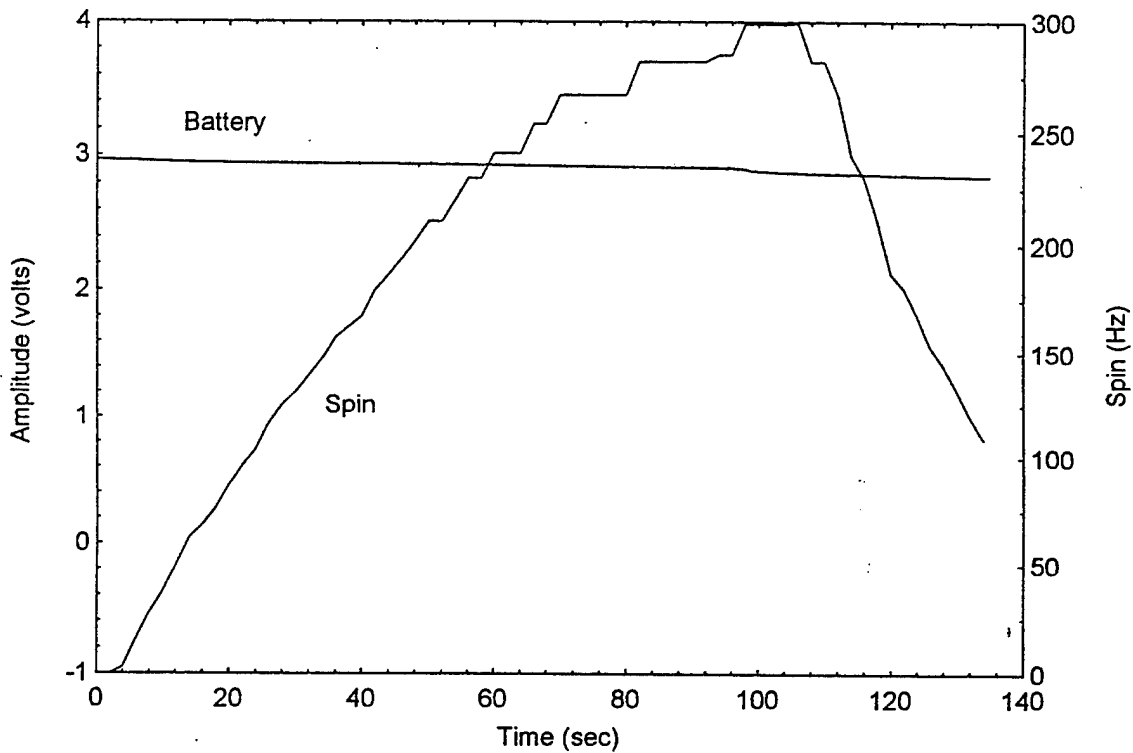

Figure 14. High-rate Li/MnO<sub>2</sub> C-size cell response vs. spin (100-mA load).

In order to prevent coil-pack movement from occurring, a mandrel is to be inserted into the center of the coil pack. At the same time, protection of the vent area of the cell will be increased by incorporating an additional component between the vent cap and the coil pack. These modifications are currently under way.

## 7. CONCLUSIONS

Under the current contract with Ultralife Batteries, the U.S. Army expects to have both the rechargeable solid polymer lithium ion and the primary Li/MnO<sub>2</sub> Thin Cell technologies fully qualified for high-g telemetry applications by 1998. The reliable performance and packaging flexibility that these technologies possess will have an immediate impact on smart-weapons testing. In the future, as operating voltages for telemetry components decrease, these technologies will allow even more flexibility.

Ultralife's primary high-rate Li/MnO<sub>2</sub> cylindrical cells are also expected to be qualified for artillery and missile applications by 1998. It is expected that this technology will offer an alternative to applications requiring a specialized reserve battery.

Flight testing of all three technologies is currently scheduled for the summer of 1997.

INTENTIONALLY LEFT BLANK.

## 8. REFERENCES

1. D'Amico, W. P., L. W. Burke, R. J. Faulstich, and A. Hooper. "The Hardened Subminiature Telemetry and Sensor System Technology and Demonstration Phase." ARL-TR-1206, U.S. Army Research Laboratory, Aberdeen Proving Ground, MD, 1996.
2. Burke, L. W., Jr., J. N. Faust, and C. E. Mitchell. "High-G and Spin Testing of Dowty Polymer Electrolyte Battery." ARL-TN-37, U.S. Army Research Laboratory, Aberdeen Proving Ground, MD, 1994.
3. Burke, L. W., Jr., R. J. Faulstich, and C. E. Newnham. "The Development and Testing of a Polymer Electrolyte Battery For High-G Telemetry Applications." Power Sources 15, by A. Atwell and T. Keilly, International Power Sources Symposium Committee, p. 295, 1995.
4. Scholey, N. "Investigation Report No. 1: U.S. Army Contract No. DAAD01-95-C-0041." Ultralife Batteries (UK) Ltd., 1995.
5. Scholey, N. "Investigation Report No. 2: U.S. Army Contract No. DAAD01-95-C-0041." Ultralife Batteries (UK) Ltd., 1995.
6. Davis, B. S., L. W. Burke, Jr., E. S. Irwin, C. R. Myers, and C. E. Mitchell. "High-G Air Gun Testing of Hardened Subminiature Telemetry and Sensor System (HSTSS) Devices." ARL-MR-306, U.S. Army Research Laboratory, Aberdeen Proving Ground, MD, June 1996.
7. Scholey, N. "Investigation Report No. 3: U.S. Army Contract No. DAAD01-95-C-0041." Ultralife Batteries (UK) Ltd., 1995.
8. Scholey, N. "Investigation Report No. 1: U.S. Army Contract No. DAAD01-96-C-0014." Ultralife Batteries (UK) Ltd., 1996.
9. Scholey, N. "Li/MnO<sub>2</sub> 'Thin Cell' Investigation Report No. 1." Ultralife Batteries (UK) Ltd., December 1995.

INTENTIONALLY LEFT BLANK.

<u>NO. OF COPIES</u>	<u>ORGANIZATION</u>
2	DEFENSE TECHNICAL INFORMATION CENTER DTIC DDA 8725 JOHN J KINGMAN RD STE 0944 FT BELVOIR VA 22060-6218
1	HQDA DAMO FDQ DENNIS SCHMIDT 400 ARMY PENTAGON WASHINGTON DC 20310-0460
1	CECOM SP & TRRSTRL COMMCTN DIV AMSEL RD ST MC M H SOICHER FT MONMOUTH NJ 07703-5203
1	PRIN DPTY FOR TCHNLGY HQ US ARMY MATCOM AMCDCG T M FISETTE 5001 EISENHOWER AVE ALEXANDRIA VA 22333-0001
1	PRIN DPTY FOR ACQUSTN HQS US ARMY MATCOM AMCDCG A D ADAMS 5001 EISENHOWER AVE ALEXANDRIA VA 22333-0001
1	DPTY CG FOR RDE HQS US ARMY MATCOM AMCRD BG BEAUCHAMP 5001 EISENHOWER AVE ALEXANDRIA VA 22333-0001
1	ASST DPTY CG FOR RDE HQS US ARMY MATCOM AMCRD COL S MANESS 5001 EISENHOWER AVE ALEXANDRIA VA 22333-0001

<u>NO. OF COPIES</u>	<u>ORGANIZATION</u>
1	DPTY ASSIST SCY FOR R&T SARD TT F MILTON THE PENTAGON RM 3E479 WASHINGTON DC 20310-0103
1	DPTY ASSIST SCY FOR R&T SARD TT D CHAIT THE PENTAGON WASHINGTON DC 20310-0103
1	DPTY ASSIST SCY FOR R&T SARD TT K KOMINOS THE PENTAGON WASHINGTON DC 20310-0103
1	DPTY ASSIST SCY FOR R&T SARD TT B REISMAN THE PENTAGON WASHINGTON DC 20310-0103
1	DPTY ASSIST SCY FOR R&T SARD TT T KILLION THE PENTAGON WASHINGTON DC 20310-0103
1	OSD OUSD(A&T)/ODDDR&E(R) J LUPO THE PENTAGON WASHINGTON DC 20301-7100
1	ARL ELECTROMAG GROUP CAMPUS MAIL CODE F0250 A TUCKER UNIVERSITY OF TX AUSTIN TX 78712
1	DUSD SPACE 1E765 J G MCNEFF 3900 DEFENSE PENTAGON WASHINGTON DC 20301-3900
1	USAASA MOAS AI W PARRON 9325 GUNSTON RD STE N319 FT BELVOIR VA 22060-5582

NO. OF  
COPIES ORGANIZATION

1 CECOM  
PM GPS COL S YOUNG  
FT MONMOUTH NJ 07703

1 GPS JOINT PROG OFC DIR  
COL J CLAY  
2435 VELA WAY STE 1613  
LOS ANGELES AFB CA 90245-5500

1 ELECTRONIC SYS DIV DIR  
CECOM RDEC  
J NIEMELA  
FT MONMOUTH NJ 07703

3 DARPA  
L STOTTS  
J PENNELLA  
B KASPAR  
3701 N FAIRFAX DR  
ARLINGTON VA 22203-1714

1 SPCL ASST TO WING CMNDR  
50SW/CCX  
CAPT P H BERNSTEIN  
300 O'MALLEY AVE STE 20  
FALCON AFB CO 80912-3020

1 USAF SMC/CED  
DMA/JPO  
M ISON  
2435 VELA WAY STE 1613  
LOS ANGELES AFB CA 90245-5500

1 US MILITARY ACADEMY  
MATH SCI CTR OF EXCELLENCE  
DEPT OF MATHEMATICAL SCI  
MDN A MAJ DON ENGEN  
THAYER HALL  
WEST POINT NY 10996-1786

1 DIRECTOR  
US ARMY RESEARCH LAB  
AMSRL CS AL TP  
2800 POWDER MILL RD  
ADELPHI MD 20783-1145

NO. OF  
COPIES ORGANIZATION

1 DIRECTOR  
US ARMY RESEARCH LAB  
AMSRL CS AL TA  
2800 POWDER MILL RD  
ADELPHI MD 20783-1145

3 DIRECTOR  
US ARMY RESEARCH LAB  
AMSRL CI LL  
2800 POWDER MILL RD  
ADELPHI MD 20783-1145

ABERDEEN PROVING GROUND

2 DIR USARL  
AMSRL CI LP (305)

<u>NO. OF COPIES</u>	<u>ORGANIZATION</u>
3	CDR US ARMY YUMA PRVNG GRND STEYT MT AT A ANDREW HOOPER YUMA AZ 85365-9110
3	CDR US ARMY YUMA PRVNG GRND STEYT RS EL RAYMOND FAULSTICH YUMA AZ 85365-9110
2	DIR US ARMY STRICOM AMCPM ITTS I RONALD COLANGELO DENNIS SCHNIDER 12350 RESEARCH PKWY ORLANDO FL 32826-3276
2	CDR NAWC WEAPONS DIV CODE 54A000D C3904 DON SCOFIELD STEVE MYERS 1 ADMINISTRATION CIR CHINA LAKE CA 93555-6001
2	CDR NAWC WEAPONS DIV GARY BORGEN DAVE POWELL POINT MUGU CA 93042-5000
2	DIR US ARMY REDSTONE TECHNICAL TEST CTR STERT TE F TD ROBERT EPPS REDSTONE ARSENAL AL 35898-8052
2	MICROCRAFT AEDC OPNS TECH 7 ANALYSIS BR JOEL SHAVER 1099 AVENUE C ARNOLD AFB TN 37389-9011

<u>NO. OF COPIES</u>	<u>ORGANIZATION</u>
	<u>ABERDEEN PROVING GROUND</u>
40	DIR USARL ATTN: AMSRL-WM, DR. I. MAY AMSRL-WM-W, C. H. MURPHY AMSRL-WM-WF, GARY HORLEY WILLIAM DOUSA JOSEPH WALL TIMOTHY KOGLER AMSRL-WM-WC, CHARLES SHOEMAKER TOM HAUG JON BORNSTEIN AMSRL-WM-WE, JANET LACETERA PAT HILL AMSRL-WM-WD, ANDRUS NIILER AMSRL-WM-WA, HARRY ROGERS LAWRENCE J. PUCKETT AMSRL-WM-WB, W. D'AMICO (2 CP) F. BRANDON B. DAVIS M. HOLLIS J. CONDON G. BROWN R. MCGEE T. HARKINS A. THOMPSON V. LEITZKE L. BURKE (5 CP) D. HEPNER E. FERGUSON D. VAZQUEZ P. MULLER E. IRWIN C. MITCHELL C. MYERS J. FAUST

NO. OF  
COPIES ORGANIZATION

2      ULTRALIFE BATTERIES (UK) LTD  
         ATTN: COLIN NEWNHAM  
         NEIL SCHOLEY  
         18 NUFFIELD WAY  
         ABINGDON, OXFORDSHIRE OX141TG  
         ENGLAND

<b>REPORT DOCUMENTATION PAGE</b>			<i>Form Approved OMB No. 0704-0188</i>	
<small>Public reporting burden for this collection of information is estimated to average 1 hour per response, including the time for reviewing instructions, searching existing data sources, gathering and maintaining the data needed, and completing and reviewing the collection of information. Send comments regarding this burden estimate or any other aspect of this collection of information, including suggestions for reducing this burden, to Washington Headquarters Services, Directorate for Information Operations and Reports, 1215 Jefferson Davis Highway, Suite 1204, Arlington, VA 22202-4302, and to the Office of Management and Budget, Paperwork Reduction Project (0704-0188), Washington, DC 20503.</small>				
1. AGENCY USE ONLY (Leave blank)	2. REPORT DATE June 1997	3. REPORT TYPE AND DATES COVERED Final, Oct 95 - Oct 96		
4. TITLE AND SUBTITLE High-G Power Sources for U.S. Army's Hardened Subminiature Telemetry and Sensor Systems (HSTSS) Program			5. FUNDING NUMBERS PR: 1L162618AH80	
6. AUTHOR(S) L. W. Burke, Jr., E. S. Irwin, R. Faulstich, C. E. Newnham, N. Scholey				
7. PERFORMING ORGANIZATION NAME(S) AND ADDRESS(ES) U.S. Army Research Laboratory ATTN: AMSRL-WM-WB Aberdeen Proving Ground, MD 21005-5066			8. PERFORMING ORGANIZATION REPORT NUMBER ARL-MR-352	
9. SPONSORING/MONITORING AGENCY NAMES(S) AND ADDRESS(ES)			10. SPONSORING/MONITORING AGENCY REPORT NUMBER	
11. SUPPLEMENTARY NOTES				
12a. DISTRIBUTION/AVAILABILITY STATEMENT Approved for public release; distribution is unlimited.			12b. DISTRIBUTION CODE	
13. ABSTRACT (Maximum 200 words) Under the Hardened Subminiature Telemetry and Sensor Systems (HSTSS) program, the U.S. Army has been developing gun-hardened telemetry devices and subsystems for the testing of smart-weapon systems. These devices will be able to withstand accelerations in excess of 100,000 g and radial accelerations in excess of 25,000 g. Under this program, rechargeable lithium ion polymer battery technology and primary lithium manganese dioxide technology are being developed for ballistic telemetry applications. To date, prototypes of these batteries have survived accelerations well over 100,000 g. This report provides the current status of these developments and reviews the battery designs and testing regimes.				
14. SUBJECT TERMS lithium ion, battery, telemetry, high-g, lithium manganese dioxide			15. NUMBER OF PAGES 34	
			16. PRICE CODE	
17. SECURITY CLASSIFICATION OF REPORT UNCLASSIFIED	18. SECURITY CLASSIFICATION OF THIS PAGE UNCLASSIFIED	19. SECURITY CLASSIFICATION OF ABSTRACT UNCLASSIFIED	20. LIMITATION OF ABSTRACT UL	

INTENTIONALLY LEFT BLANK.

## USER EVALUATION SHEET/CHANGE OF ADDRESS

This Laboratory undertakes a continuing effort to improve the quality of the reports it publishes. Your comments/answers to the items/questions below will aid us in our efforts.

1. ARL Report Number/Author ARL-MR-352 (Burke) Date of Report June 1997

2. Date Report Received \_\_\_\_\_

3. Does this report satisfy a need? (Comment on purpose, related project, or other area of interest for which the report will be used.) \_\_\_\_\_  
\_\_\_\_\_  
\_\_\_\_\_

4. Specifically, how is the report being used? (Information source, design data, procedure, source of ideas, etc.) \_\_\_\_\_  
\_\_\_\_\_  
\_\_\_\_\_

5. Has the information in this report led to any quantitative savings as far as man-hours or dollars saved, operating costs avoided, or efficiencies achieved, etc? If so, please elaborate. \_\_\_\_\_  
\_\_\_\_\_  
\_\_\_\_\_

6. General Comments. What do you think should be changed to improve future reports? (Indicate changes to organization, technical content, format, etc.) \_\_\_\_\_  
\_\_\_\_\_  
\_\_\_\_\_

**CURRENT  
ADDRESS**

\_\_\_\_\_  
Organization

\_\_\_\_\_  
Name

\_\_\_\_\_  
E-mail Name

\_\_\_\_\_  
Street or P.O. Box No.

\_\_\_\_\_  
City, State, Zip Code

7. If indicating a Change of Address or Address Correction, please provide the Current or Correct address above and the Old or Incorrect address below.

**OLD  
ADDRESS**

\_\_\_\_\_  
Organization

\_\_\_\_\_  
Name

\_\_\_\_\_  
Street or P.O. Box No.

\_\_\_\_\_  
City, State, Zip Code

(Remove this sheet, fold as indicated, tape closed, and mail.)

**(DO NOT STAPLE)**