

1 6 SEP 1997



**Center for Combustion  
and Environmental  
Research**

**Nonsteady Combustion Mechanisms of Advanced  
Solid Propellants**

**AFOSR Grant No. DOD-F49620-93-0430**

**M.C. Branch, University of Colorado  
M.W. Beckstead, Brigham Young University  
T.A. Litzinger, Pennsylvania State University  
M.D. Smooke, Yale University  
V.H. Yang, Pennsylvania State University**

**PROGRESS REPORT – SEPTEMBER 1, 1997**

**CCER Report No. 97-02**

*Center for Combustion and Environmental Research  
Department of Mechanical Engineering  
University of Colorado at Boulder  
Boulder, Colorado 80309-0427  
Tel: 303/492-7427, Fax: 303/492-2199  
Email: [branch@spot.colorado.edu](mailto:branch@spot.colorado.edu)*

**DTIC QUALITY INSPECTED 3**

**19971006 069**

**DISTRIBUTION STATEMENT A**

**Approved for public release;  
Distribution Unlimited**

# REPORT DOCUMENTATION PAGE

Public reporting burden for this collection of information is estimated to average 1 hour per response, including the gathering and maintaining of the data needed, and completing and reviewing the collection of information. Send comments regarding this burden estimate or any aspect of this collection of information, including suggestions for reducing the burden, to Washington Headquarters Services, Directorate for Information Operations and Reports, 1215 Jefferson Avenue, Washington, DC 20540-4301, and to the Office of Management and Budget, Paperwork Reduction Project (97-0302).

0502

1. AGENCY USE ONLY (Leave blank)		2. REPORT DATE Sept. 1, 1997	3. REPORT TYPE AND DATES COVERED Final Technical Report	
4. TITLE AND SUBTITLE Nonsteady Combustion Mechanisms of Advanced Solid Propellants			5. FUNDING NUMBERS F49620-93-0430  3484/AS	
6. AUTHOR(S) Melvyn C. Branch				
7. PERFORMING ORGANIZATION NAME(S) AND ADDRESS(ES) Mechanical Engineering Department University of Colorado Boulder, Colorado 80309-0427			8. PERFORMING ORGANIZATION REPORT NUMBER	
9. SPONSORING / MONITORING AGENCY NAME(S) AND ADDRESS(ES) AFOSR/NA 110 Duncan Avenue, Suite B115 Bolling AFB, DC 20332-0001			10. SPONSORING MONITORING AGENCY REPORT NUMBER	
11. SUPPLEMENTARY NOTES				
12a. DISTRIBUTION / AVAILABILITY STATEMENT Approved for public release; distribution is unlimited.			12b. DISTRIBUTION CODE	
13. ABSTRACT (Maximum 200 words)  This report describes progress on a collaborative research program combining the expertise of individuals from several universities to develop a new ability to predict the propulsion performance of solid rocket motors. The focus of the research on nonsteady behavior is unique and the overall project is not possible at any one of the institutions participating in this coordinated research. The individual tasks which we are studying will pursue solid propellant decomposition under unsteady conditions, nonsteady aspects of gas phase flame structure measurements, numerical modeling of multidimensional flame structure, propellant/flame interactions and overall nonsteady propellant combustion characteristics in realistic rocket motor environments. Our goal has been to develop general models of fundamental mechanisms of combustion instability that can be applied to a variety of new energetic materials.				
14. SUBJECT TERMS Solid Rocket Combustion Nonsteady Combustion			15. NUMBER OF PAGES	
			16. PRICE CODE	
17. SECURITY CLASSIFICATION OF REPORT unclassified	18. SECURITY CLASSIFICATION OF THIS PAGE unclassified	19. SECURITY CLASSIFICATION OF ABSTRACT unclassified	20. LIMITATION OF ABSTRACT u1	

# NONSTEADY COMBUSTION MECHANISMS OF ADVANCED SOLID PROPELLANTS

AFOSR Grant No. DOD-F49620-93-0430

M.C. Branch, University of Colorado  
M.W. Beckstead, Brigham Young University  
T.A. Litzinger, Pennsylvania State University  
M.D. Smooke, Yale University  
V.H. Yang, Pennsylvania State University

## SUMMARY/OVERVIEW

This report describes progress during the third year of a collaborative research program combining the expertise of individuals from several universities to develop a new ability to predict the propulsion performance of solid rocket motors. The focus of the research on nonsteady behavior is unique and the overall project is not possible at any one of the institutions participating in this coordinated research. The individual tasks which we are studying will pursue solid propellant decomposition under unsteady conditions, nonsteady aspects of gas phase flame structure measurements, numerical modeling of multidimensional flame structure, propellant/flame interactions and overall nonsteady propellant combustion characteristics in realistic rocket motor environments. Our goal is to develop general models of fundamental mechanisms of combustion instability that can be applied to a variety of new energetic materials.

## TECHNICAL DISCUSSION

The objectives of MPMS studies were to determine the chemical mechanisms for HMX, GAP, and HMX/GAP(80% HMX and 20% GAP by weight) propellants during steady state laser-assisted burning, and to determine the response of gas-phase species and burning rate of HMX during sinusoidal laser heating. A triple quadrupole mass spectrometer (TQMS) and quartz microprobes are used to obtain quantitative species profiles above the surface of the sample during CO<sub>2</sub> laser induced decomposition or during laser assisted deflagration of the samples. Gas phase temperature profiles are also measured with micro-thermocouples no larger than 75 micron. The results of the studies provide the boundary conditions at the interface between the condensed and gas phases which is critical for modeling. In addition they provide gas phase species and temperature profiles over a range of experimental conditions that will be used to test the models.

### Steady State Measurements

HMX, GAP, and HMX/GAP(80% HMX and 20% GAP by weight) propellants were investigated at atmospheric pressure in argon with laser heating. Because most of the work has been summarized in past reports, only the HMX/GAP propellant results will be discussed here. For the HMX/GAP propellant, a long ignition delay of 1.5 sec was usually observed at a heat flux of 100 W/cm<sup>2</sup>, while an ignition delay of 42 ms was found at a heat flux of 300 W/cm<sup>2</sup>. At

a heat flux of  $100 \text{ W/cm}^2$ , a significant amount of carbonaceous residue was observed on the burning surface. In contrast, a small amount of carbonaceous residue was found only at the edge of the propellant at a heat flux of  $300 \text{ W/cm}^2$ .

Figure 1 displays species profiles for HMX/GAP at atmospheric pressure in argon with a heat flux of  $100 \text{ W/cm}^2$ . The species profiles display three distinctive regions: the primary reaction zone, the preparation zone, and the secondary reaction zone. The primary reaction zone extends from 0 to 0.5 mm above the surface. The reactions are evidenced by the fact that  $\text{H}_2\text{O}$  and  $\text{NO}_2$  are consumed as  $\text{NO}$ ,  $\text{CO}$ ,  $\text{CO}_2$ , and  $\text{H}_2\text{O}$  are produced. A steep temperature rise was observed just above the surface, which is in line with the highly exothermic reaction near the surface. At the end of the primary reaction zone,  $\text{NO}_2$  is almost totally consumed but some  $\text{H}_2\text{CO}$  remains. The preparation zone lasts from 0.5 to 2.7 mm above the surface. In this region, all the species profiles are relatively flat, which is consistent with the observed flat temperature profile after the sharp temperature rise. The secondary reaction zone starts from 2.7 mm above the surface, where  $\text{NO}$  and  $\text{HCN}$  are consumed and  $\text{N}_2$  and  $\text{CO}$  are produced at a similar rate. After the  $\text{NO}$  is completely consumed in the secondary reaction zone, some  $\text{HCN}$  remains, at a mole fraction of 0.02, which is consistent with the fuel-rich composition for the HMX/GAP propellant. It is noteworthy that the mole fraction of  $\text{H}_2\text{O}$  did not increase from 3.5 to 4.2 mm above the surface. This is consistent with the fact that  $\text{HCN}$  and  $\text{NO}$  will react without forming water.

Though only 20% GAP was added into pure HMX, the gas-phase zonal structures were significantly different between laser-assisted combustions of HMX/GAP and pure HMX. The HMX/GAP flame displayed a narrow primary reaction zone and a relatively long preparation zone between the primary and secondary reactions, while the pure HMX flame showed a long primary reaction zone and no preparation zone before the secondary reaction zone. The high exothermic condensate-phase reaction of GAP could increase the condensate-phase temperature of HMX/GAP, and the observed increase in gas-phase temperature will accelerate the reaction between  $\text{H}_2\text{CO}$  and  $\text{NO}_2$  near the surface. Thus, the primary reaction zone was considerably shorter in the HMX/GAP flame. Several factors could account for the fact that the secondary reaction zone did not occur right after the primary reaction zone in the HMX/GAP flame. The higher burning rate for HMX/GAP could be part of the reason because the higher gas velocity requires a longer distance to achieve the same reaction time. The fuel-rich gas mixture could also be a contributing factor because addition of GAP increased the fuel to oxidizer ratio. It was evident that the mole fraction of  $\text{HCN}$  at the surface for the HMX/GAP flame was higher than that for the HMX flame. Thus, the higher gas velocity and the large amount of  $\text{HCN}$  could significantly delay occurrence of the secondary reaction in the HMX/GAP flame.

### Unsteady Measurements for HMX

Over the last year of the program, a new experimental facility was designed and constructed which permitted the study of the response of HMX to sinusoidal laser heat fluxes. (This facility was funded mainly through the MURI funds from ONR and BMDO.) With this system, thrust, species, flame height, and light emission responses to a sinusoidal heat flux were measured at frequencies from 3.9 to 250 Hz and mean heat fluxes from  $35$  to  $90 \text{ W/cm}^2$  for HMX pellets. The  $\text{CO}_2$  laser with associated electronics and software was used to provide a sinusoidal heat flux. The laser system has been proven to be an effective tool for the tests of the laser-driven response function. All tests were done using a heat flux sweep with discrete

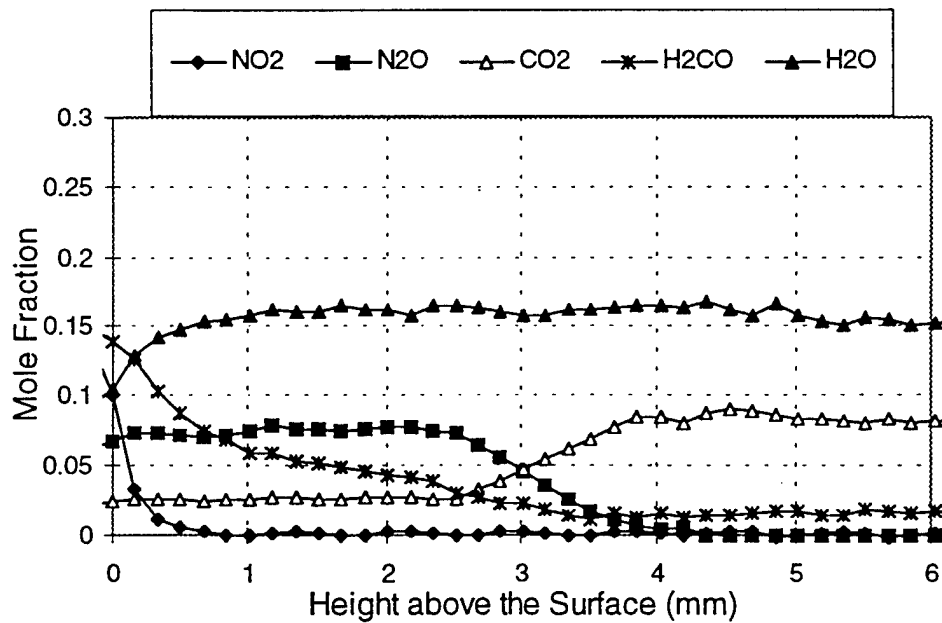
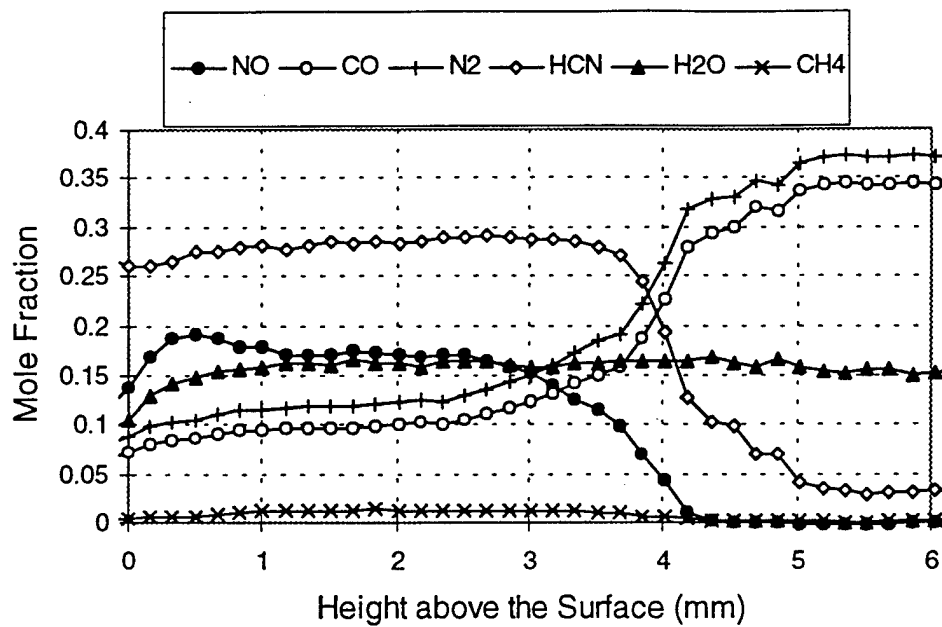

Figure 1: Species profiles above the surface of HMX during laser-assisted combustion at one atmosphere and a heat flux of  $100 \text{ W/cm}^2$

increments of frequency. The time interval for each frequency always covered several cycles. This unique sweep technique has the advantages of using much less material, normally one single sample, to cover a given frequency range and of reducing the uncertainties arising from separate tests. Thus, less material was consumed, and relatively good data was produced.

The microprobe/TQMS system was successfully applied for measuring the species under oscillating conditions. The stable species response to sinusoidal laser heating had not been obtained by earlier researchers. The results for the secondary flame region of HMX showed that

NO always oscillated in phase with HCN, but  $180^\circ$  out of phase with  $N_2$ . The results were in line with the relations between product( $N_2$ ) and reactants(HCN and NO).

Figure 2 is a plot of the HMX oscillation amplitudes and phases for the flame height, thrust, light emission, and species responses as a function of frequency. The four sets of data were obtained at a mean heat flux of  $60 \text{ W/cm}^2$ . The thrust phase response shows a phase lead at frequencies below 12 Hz and a phase lag approaching  $100^\circ$  at 125 Hz. Theoretically, the resonant peak should be at a frequency where the phase changes from lead to lag. Both the thrust amplitude and phase relations indicate a resonant peak of 11-15 Hz. The light phase always lagged behind the thrust phase, and the thrust and light phases diverged with an increase in frequency. The species phase was negative at all frequencies, but the amplitude response suggests a peak at approximately 10 Hz. The difference between the thrust and species response functions suggests that the species composition at the surface varied with burning rate, which was observed during self-oscillating burning, to be discussed in the next paragraph.

Oscillating burning was also observed at a constant heat flux of  $30 \text{ W/cm}^2$ . Simultaneous surface temperature and species measurements were performed at the condition. This unique experimental technique enabled the relationship of the surface temperature to all the stable species at the surface under the transient conditions to be determined. During the test, oscillations of species, temperature, and regression rates were observed and were found to occur at a frequency of approximately 4 Hz.  $NO_2$ , HCN, and triazine oscillated in phase with temperature, whereas  $N_2O$ ,  $H_2CO$ , and the species at mass 28 were  $180^\circ$  out of phase with temperature. The production of  $NO_2$  and HCN was favored with an increase in temperature and burning rate, while the production of  $N_2O$  and  $H_2CO$  became more important with a decrease in temperature and burning rate. This was qualitatively in line with the competing reaction branches proposed by Brill and others for the condensed-phase reaction of HMX.

### Gas Phase Flame Processes (Branch)

The development of detailed models of solid propellant combustion requires detailed information on the gas-phase chemistry occurring above the propellant surface. Different flame systems have been identified as important to study in order to gain greater understanding of solid propellant gas-phase chemistry. In particular, systems that need study are flames of carbon monoxide and hydrocarbons burning with nitrogen oxides. Since both premixed and diffusion flame chemistries exist above the propellant surface, premixed and diffusion flames involving these reactants need to be studied. In the past decade, several experimental studies have been made of premixed flames consisting of these reactants. More recently, counterflow diffusion flames consisting of these reactants have been studied as well. In the present work, several different premixed and counterflow diffusion flames have been modeled using a common, 275-reaction mechanism.

Solid propellant combustion models require gas-phase chemical kinetic mechanisms that are as small as possible. Therefore, for each premixed flame system studied, sensitivity and rate generation analyses have been used to identify which reactions in the detailed mechanism are critical to each system. Based on these analyses, and comparisons with the experimental data, reduced mechanisms, consisting of only the essential chemical reactions for each flame system, have been developed. These reduced mechanisms have been combined into a comprehensive, reduced mechanism consisting of 42 reactions. In general, this reduced mechanism models the flames' chemistry as accurately as the full mechanism does.

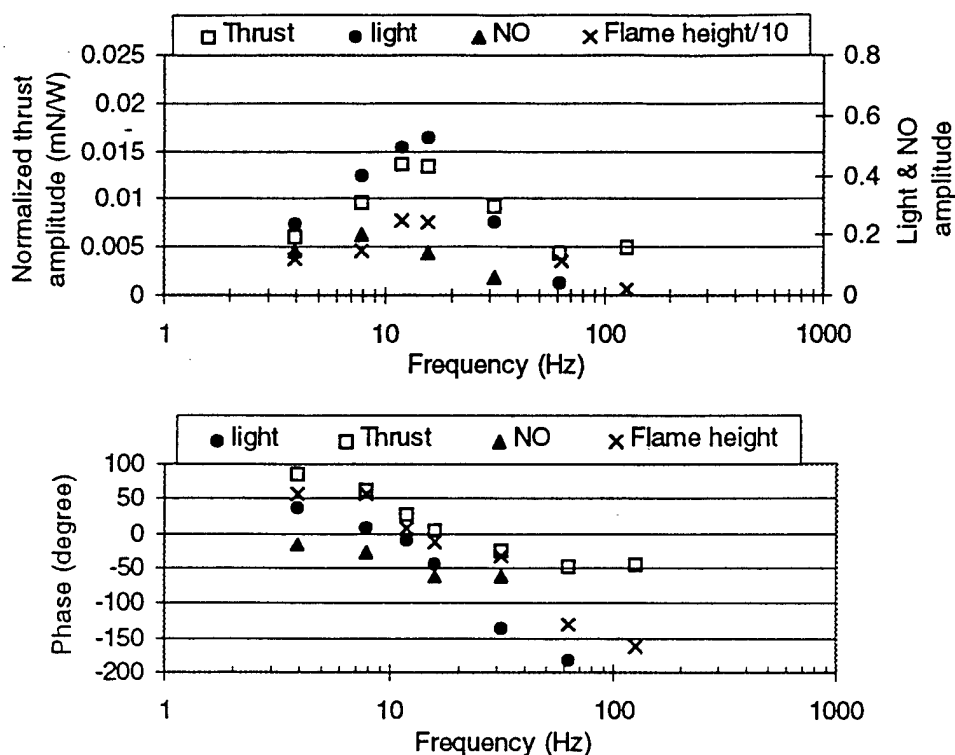

Figure 2: HMX gas-phase species amplitude and phase responses compared with thrust, flame height, and light emission signals.

The full and reduced mechanisms have also been used to model methane-nitrous oxide and carbon monoxide-nitrous oxide counterflow diffusion flames. From comparisons with the experimental data, it is determined that, in general, the full mechanism and the reduced mechanism model the diffusion flame chemistry as accurately as they modeled the premixed flame chemistry. Also, in the diffusion flames, there is reasonable agreement between the modeling results using the full and reduced mechanism.

The problem of  $N_2O$  decomposition remains a key area requiring further study. The rate constants for this reaction had to be modified to model the  $CO-N_2O$  flames and the  $CH_4-N_2O$  diffusion flame accurately. The reason for this discrepancy is still to be determined, but future studies of the  $N_2O$  decomposition reaction are suggested.

#### Monopropellant Burning Model (Smooke)

Our research has focused on the development and application of computational models that can be used to elucidate information related to the burning of nitramine propellants. The work focused on three specific projects, each of which is described in some detail below.

A model was developed that applied detailed chemistry and complex transport to a two-dimensional flame in which a fuel stream was sandwiched between two oxidizer streams. The work focused on the burning of fuel- $N_2O$  flames in a Wolfhard-Parker configuration. Unlike some models in which diffusion in the downstream direction was neglected, we have treated the fully elliptic problem. A discrete solution was obtained by combining a steady-state and a time-dependent solution method. A time-dependent approach was used to help obtain a converged

numerical solution on an initial coarse grid using a flame sheet starting estimate. Grid points were inserted adaptively and Newton's method was used to complete the problem. The model was used to compare temperature and species profiles with experimental measurements made at the University of Colorado. Both  $\text{CH}_4\text{-N}_2\text{O}$  and  $\text{CO-N}_2\text{O}$  flames were considered. The results of this investigation enabled the probing of the fluid dynamic and thermochemistry interaction and its effect on the structure of fuel/ $\text{N}_2\text{O}$  flames.

A computational model was developed which is applicable to the study of HMX combustion. The three-tiered model allowed for solid, liquid and gaseous phases of HMX. The resulting nonlinear two-point boundary value problem was solved by Newton's method with adaptive gridding. In the model the burning rate was computed as an eigenvalue which removed the uncertainty associated with employing evaporation and condensation rate laws in its evaluation. We have applied the model to the study of both laser-assisted and self-deflagration of HMX monopropellants and we have compared the results with experimental measurements made at China Lake. The burning rates have been computed over a wide range of pressures and they compare well with experimental results from one to ninety atmospheres. The burning rate is found to be proportional to the pressure raised to the 0.82 power. Sensitivity of the burning rate to initial propellant temperature was calculated and found to be extremely low which is in agreement with past theoretical predictions and experimental data. Results for self-deflagration studies do not indicate a two-zone flame. Laser-assisted studies illustrate a distinct primary and secondary flame separated by a dark zone, the length of which is dependent upon the incident laser flux intensity.

The HMX model was modified to study the combustion of HMX propellants over the pressure range of 90-3400 atm. New to this effort was the treatment of the gas-phase as non-ideal. The Becker-Kistiakowsky-Wilson (BKW) equation of state was used to relate the compressibility factor to the pressure, density, gas constant and temperature. Thermodynamic properties were then derived from standard-state (ideal gas) mixture properties plus real gas mixture departure functions. Reverse rate constants were obtained from the forward rate constants, compressibility factor and the fugacity based equilibrium constants. Results of the deflagration rate as a function of pressure were found to be in good agreement with recent experimental data. Differences in HMX burn rates predicted by the ideal and non-ideal gas-phase models are attributed to the resulting heat flux differences at the HMX gas-liquid interface.

#### Propellant Combustion and Chamber Dynamics (Yang)

Results obtained from the preceding tasks provide a concrete basis for understanding the detailed combustion mechanisms of solid propellants in an isolated environment. To extend these fundamental investigations to practical motor design issues, it is important to study the propellant burning behavior under conditions representative of realistic rocket motor environments. Most previous research on motor interior ballistics was either focused on cold-flow simulation or based on simplified approaches with propellant burning rates modeled by empirical formulas. Very limited is known about detailed physico-chemical processes near the propellant surface which dictate the burning characteristics. The purpose of this task is to remedy these technical and scientific deficiencies by treating the intricate interactions between local flow motions and chemical reactions at scales sufficient for resolving the rapid variations of flow properties in the near field. Both steady and oscillatory conditions are considered. The

work mainly addresses two issues: how the motor internal flow is established by propellant burning, and how the local flowfield affects propellant burning.

During the past year, a series of analyses have been conducted to study the combustion characteristics of AP/HTPB composite propellants in two-dimensional chambers, as shown in Fig. 3. The formulation is based on the complete conservation equations for both gas and condenses phases, with full account taken of variable transport and thermodynamic properties. Only the reduced chemical kinetics schemes established in the flame chemistry studies are incorporated into the flow solver to render numerical calculations manageable. Turbulence closure is achieved using a modified turbulent transport model which takes into account the wall-blowing effect arising from propellant burning. Specific processes investigated include:

- Motor internal flow development over a broad range of operating conditions, including onset of turbulence and its ensuing growth;
- Detailed flame structure near the propellant surface, including the micro-scale energy cascade from exothermic reactions to flow motions;
- Coupling between gas and condenses phases, including subsurface degradation and surface regressions processes;
- interactions between acoustic wave and flame dynamics in the gas phase, including the mutual couplings among the acoustic, vortical, and entropy modes as well as their influences on heat-release mechanisms, and
- dynamics responses of propellant burning to local flow oscillations, including transient variations of subsurface heat release and thermal-wave penetration.

The model appears to be the first and most complete of its kind to date, providing comprehensive information about propellant combustion and motor chamber dynamics. The instantaneous burning rate of propellant is calculated as part of the solution from first principles. Figure 4 shows a typical result of the spatial distribution of Rayleigh's parameter. The problem investigated involves a two-dimensional chamber loaded with composite propellant subject to periodically forced oscillations at the chamber exit. This result can be effectively used to identify the day mechanism responsible for driving combustion instabilities in rocket motors. In particular, the effects of spatial distribution and temporal evolution of the heat-release process, as well as their mutual coupling with local flow motions, on motor stability can be clearly examined.

## Unsteady Motor Flows Coupled with Propellant Combustion Responses

- Fluid dynamic processes that dictate the environment in which chemical reactions occur.
- Chemical processes that provide the energy for driving instabilities.

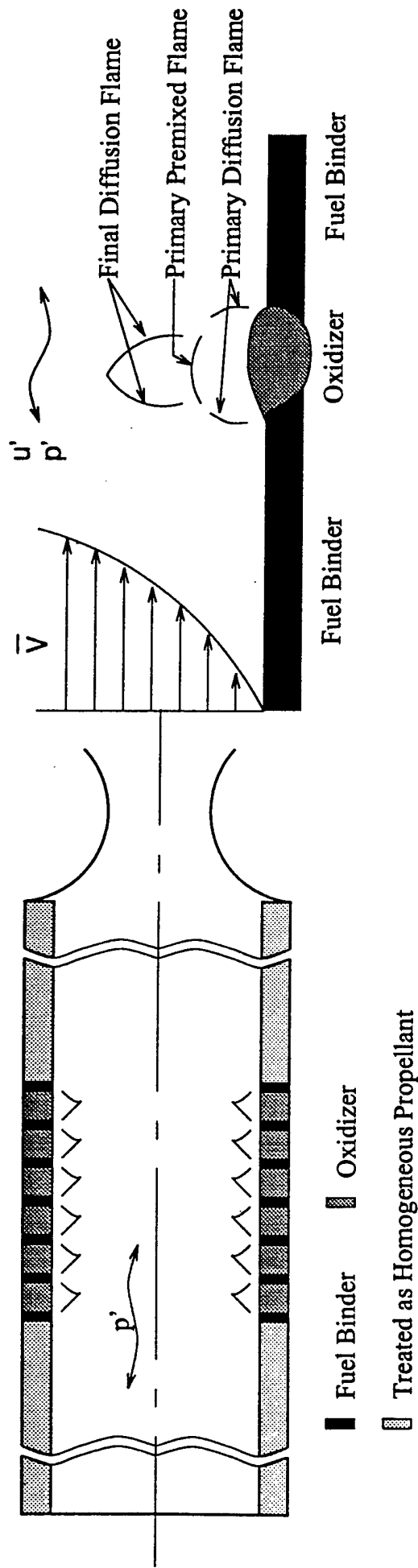

Fig. 3 Schematic diagram of a rocket motor with AP/HTPB composite propellant.

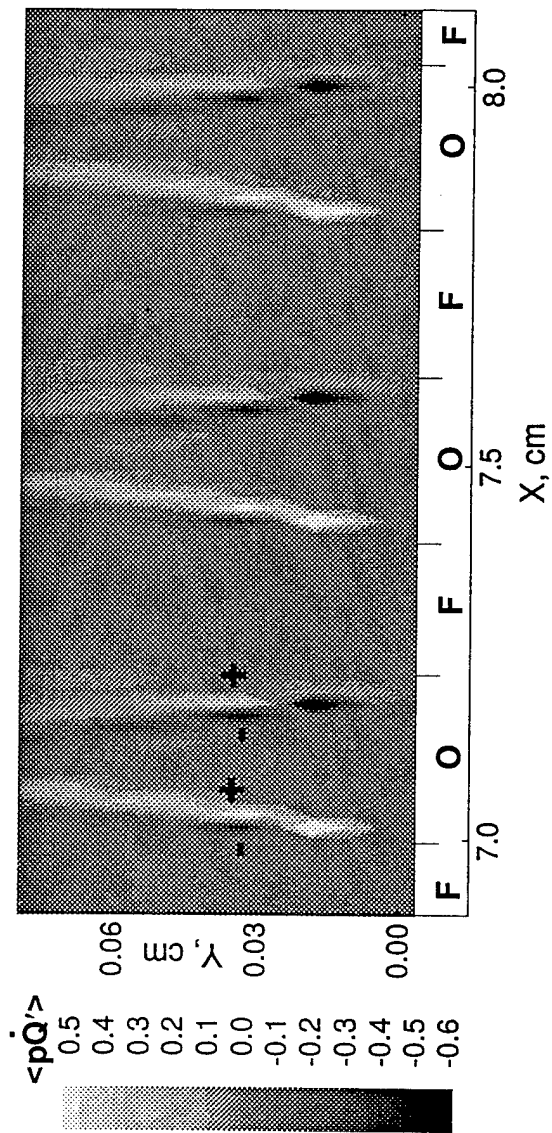

Fig. 4. Spatial Distribution of Rayleigh's Parameter,  $\langle \dot{p}\dot{Q} \rangle$

**Principal Investigator Annual Data Collection- FY 97**  
**( From 1 September 1996 to 31 August 1997)**

ATCH 4

NAME (Last, First, MI): Branch, Melvyn C.

INSTITUTION: University of Colorado at Boulder

GRANT NUMBER: F49620 - 9 3 -     - 0 4 3 0

(Obtain the grant numbers above from your University Contracts and Grants Office)

---

Please Answer the questions below with the total numbers for the Period 1 September 1996 to 31 August 1997 related to the above grant :

How Many Faculty members are involved in the above grant/contract? TOTAL   1  

How Many Post-Doctorates? US Cit   1   Non-US     TOTAL   1  

How Many Graduate Stud. ? US Cit   2   Non-US     TOTAL   2  

Others? ..... Undergraduates (US) ..... TOTAL   1  

Number of Publications in the Peer Reviewed Journals TOTAL   3  

Books or Book Chapters Published TOTAL    

Number of Awards Received in general TOTAL    

---

In a second page(use additional pages if necessary), please give detail answers to the following questions :

- 1) List all your publications in Peer Reviewed Journals for the period as a product of the above grant/contract(Authors, Title, Journal, Vol, Nr, Year, pp)
- 2) Books or Book Chapters published in the period
- 3) List all the awards you received in detail during the period
- 4) Participation/presentations at meetings, conferences etc.
- 5) Consultative and advisory functions to other laboratory and agencies, especially Air Force and other DoD laboratories

Branch, M.C.

#### 1. LIST OF PUBLICATIONS

J.J. Cor, M.C. Branch, C.B. Dreyer, P.J. Van Tiggelen, and H.M. Tsai, "Studies of Methane and Carbon-Monoxide-Nitrous Oxide Diffusion Flames at Low Pressure," *Proceedings of the 31<sup>st</sup> JANNAF Combustion Meeting*, CPIA Pub. No. 585, 2, pp. 231-238, 1996.

J.J. Cor, C.B. Dreyer, and M.C. Branch, "Mechanistic Studies of Low Pressure Flames Supported by Nitrogen Oxides", *Proceedings of the 4<sup>th</sup> International Symposium on Special Topics in Chemical Propulsion*, in press.

J.J. Cor and M.C. Branch, "Studies of Counterflow Diffusion Flames at Low Pressure", *Combustion Science and Technology*, in press.

#### 4. PARTICIPATION/PRESENTATIONS AT MEETINGS

J.J. Cor, C.B. Dreyer and M.C. Branch, "Reduced Mechanistic Studies of Low Pressure Premixed and Counterflow Diffusion Flames Supported by Nitrogen Oxides", *WSS/CI Paper No. 96F-117*, Western States Section/The Combustion Institute, University of Southern California, Pasadena, October 28-29, 1996.

M.C. Branch, "Nonsteady Combustion Mechanisms of Advanced Solid Propellants", ARO and AFOSR Contractors Meeting in Chemical Propulsion, Hampton University, pp. 51-55, 1996.

M.C. Branch, "Premixed Counterflow Diffusion, and Counterflow Triple Flame Structure", ONERA, Palaiseau, France, November 26, 1996.

**Principal Investigator Annual Data Collection- FY 97**  
**( From 1 September 1996 to 31 August 1997)**

ATCH 4

NAME (Last, First, MI): Litzinger, Thomas A.

INSTITUTION: Pennsylvania State University

GRANT NUMBER: F49620 - 9 3 -     - 0 4 3 0

(Obtain the grant numbers above from your University Contracts and Grants Office)

---

Please Answer the questions below with the total numbers for the Period 1 September 1996 to 31 August 1997 related to the above grant :

How Many Faculty members are involved in the above grant/contract? TOTAL   1  

How Many Post-Doctorates? US Cit     Non-US     TOTAL   0  

How Many Graduate Stud. ? US Cit     Non-US   1   TOTAL   1  

Others? ..... TOTAL    

Number of Publications in the Peer Reviewed Journals TOTAL   0  

Books or Book Chapters Published TOTAL   0  

Number of Awards Received in general TOTAL   0  

---

In a second page(use additional pages if necessary), please give detail answers to the following questions :

1) List all your publications in Peer Reviewed Journals for the period as a product of the above grant/contract(Authors, Title, Journal, Vol, Nr, Year, pp)

2) Books or Book Chapters published in the period

3) List all the awards you received in detail during the period

4) Participation/presentations at meetings, conferences etc.

5) Consultative and advisory functions to other laboratory and agencies, especially Air Force and other DoD laboratories

Litzinger, T.A.

PRESENTATIONS FOR LAST YEAR:

Tang, C.\*, Y. Lee\*, G. Kudva\* and T. Litzinger, "A Study of the Combustion Response of HMX Mono-propellant to Sinusoidal Laser Heating", *JANNAF Combustion Meeting*, Monterey, CA, 10 pp. (November 1996).

Tang, C.\*, Y. Lee\*, G. Kudva\* and T. Litzinger, "A Study of the Combustion Response of HMX Mono-propellant to Sinusoidal Laser Heating", *Fall Technical Meeting of the Eastern States Section of the Combustion Institute*, Hilton Head, SC, 4 pp. (December 1996).

5. None

**Principal Investigator Annual Data Collection- FY 97**  
**( From 1 September 1996 to 31 August 1997)**

ATCH 4

NAME (Last, First, MI): Smooke, Mitchell D.

INSTITUTION: Yale University

GRANT NUMBER: F49620 - 9 3 -     - 0 4 3 0

(Obtain the grant numbers above from your University Contracts and Grants Office)

---

Please Answer the questions below with the total numbers for the Period 1 September 1996 to 31 August 1997 related to the above grant :

How Many Faculty members are involved in the above grant/contract? TOTAL   1  

How Many Post-Doctorates? US Cit   1   Non-US   1   TOTAL   2  

How Many Graduate Stud. ? US Cit    Non-US    TOTAL   0  

Others? ..... TOTAL   0  

Number of Publications in the Peer Reviewed Journals TOTAL   2  

Books or Book Chapters Published TOTAL   0  

Number of Awards Received in general TOTAL   0  

---

In a second page(use additional pages if necessary), please give detail answers to the following questions :

- 1) List all your publications in Peer Reviewed Journals for the period as a product of the above grant/contract(Authors, Title, Journal, Vol, Nr, Year, pp)
- 2) Books or Book Chapters published in the period
- 3) List all the awards you received in detail during the period
- 4) Participation/presentations at meetings, conferences etc.
- 5) Consultative and advisory functions to other laboratory and agencies, especially Air Force and other DoD laboratories

### **Publications (Journal Articles):**

K. Prasad, R. Yetter and M. D. Smooke, "An Eigenvalue Method for Predicting the Burning Rate of RDX Propellants," in press *Comb. Sci. and Tech.*, **124**, (1997).

K. Prasad, R. A. Yetter, M. D. Smooke, T. P. Parr and D. Hanson-Parr, "An Eigenvalue Method for Computing the Burning Rates of HMX Propellants, submitted to *Comb. Sci. and Tech.*, (1997).

### **Meetings and Conferences**

JANNAF Combustion Meeting, Monterey, California, November 1996

1996 Eastern States Sectional Meeting, Hilton Head, South Carolina, December, 1996.

AIAA Annual Meeting, Reno, Nevada, January 1997

NASA Microgravity Meeting, Cleveland, Ohio, May, 1997.

DOE Combustion Review Meeting, Fairfax, Virginia, May, 1997.

**Principal Investigator Annual Data Collection - FY 97**  
(From 1 September 1996 to 31 August 1997)

ATCH 4

NAME (Last, First, MI): YANG, VIGOR

INSTITUTION: Pennsylvania State University

GRANT NUMBER: F49620 - 9 - 3 - 0 - 4 - 3 - 0

(Obtain the grant numbers above from your University Contracts and Grants Office)

---

Please answer the questions below with the total numbers for the Period 1 September 1996 to 31 August 1997 related to the above grant:

How Many Faculty members are involved in the above grant/contract?	TOTAL	<u>1</u>
How Many Post-Doctorates? US Cit <u>    </u> Non-US <u>1</u>	TOTAL	<u>1</u>
How Many Graduate Stud.? US Cit <u>1</u> Non-US <u>1</u>	TOTAL	<u>2</u>
Others? .....	TOTAL	<u>0</u>
Number of Publications in the Peer Reviewed Journals	TOTAL	<u>0</u>
Books or Book Chapters Published	TOTAL	<u>0</u>
Number of Awards Received in general	TOTAL	<u>0</u>

---

In a second page (use additional pages if necessary), please give detailed answers to the following questions:

1) List all your publications in Peer Reviewed Journals for the period as a product of the above grant/contract (Authors, Title, Journal, Vol, Nr. Year, pp)

Chu, W.W., and Yang, V., "Interactions between Acoustic Waves and Diffusion Flames in Porous Chambers," submitted to *Combustion and Flame*.

Tseng, C.F., Chu, W.W., and Yang, V., "Interactions between Acoustic Waves and Premixed Flames in Porous Chambers," submitted to *Combustion and Flame*.

Roh, T.S., and Yang, V., "Transient Combustion Responses of Solid Propellants to Acoustic Oscillations in Rocket Motors," submitted to *Journal of Propulsion and Power*.

2) **Books or Book Chapters published in the period**

None.

3) **List all the awards you received in detail during the period**

None.

4) **Participation/presentations at meetings, conferences etc.**

Chu, W.W., and Yang, V., "Combustion of AP/HTPB Composite Propellant in a Rocket Motor Flow Environment," presented at 33<sup>rd</sup> JANNAF Combustion Meeting, November 1996.

Yang, V., "Recent Advances in Solid-Propellant Rocket Motor Internal Flow Analysis," Australia Defence Science and Technology Organisation, Adelaide, Australia, December 1996.

5) **Consultative and advisory functions to other laboratory and agencies, especially Air Force and other DoD laboratories**

Close collaboration has been maintained with Mr. Jay N. Levine of the Air Force Phillips Laboratory and Dr. Fred Blomshield of the Navy Air Warfare Center since the inception of this research program.