

RL-TR-96-254
Final Technical Report
March 1997



OPTICALLY ACTIVE MATERIAL CYLINDER FIBERS

Syracuse University

Philipp Kornreich

APPROVED FOR PUBLIC RELEASE; DISTRIBUTION UNLIMITED.

19971016 064

Rome Laboratory
Air Force Materiel Command
Rome, New York

DTIC QUALITY INSPECTED 2

This report has been reviewed by the Rome Laboratory Public Affairs Office (PA) and is releasable to the National Technical Information Service (NTIS). At NTIS it will be releasable to the general public, including foreign nations.

RL-TR-96-254 has been reviewed and is approved for publication.

APPROVED: *David Grucza*
DAVID J. GRUCZA
Project Engineer

FOR THE COMMANDER: *Donald W. Hanson*
DONALD W. HANSON, Director
Surveillance & Photonics Directorate

If your address has changed or if you wish to be removed from the Rome Laboratory mailing list, or if the addressee is no longer employed by your organization, please notify RL/OCPA, 25 Electronic Pky, Rome, NY 13441-4514. This will assist us in maintaining a current mailing list.

Do not return copies of this report unless contractual obligations or notices on a specific document require that it be returned.

REPORT DOCUMENTATION PAGE			Form Approved OMB No. 0704-0188	
Public reporting burden for this collection of information is estimated to average 1 hour per response, including the time for reviewing instructions, searching existing data sources, gathering and maintaining the data needed, and completing and reviewing the collection of information. Send comments regarding this burden estimate or any other aspect of this collection of information, including suggestions for reducing this burden, to Washington Headquarters Services, Directorate for Information Operations and Reports, 1215 Jefferson Davis Highway, Suite 1204, Arlington, VA 22202-4302, and to the Office of Management and Budget, Paperwork Reduction Project (0704-0188), Washington, DC 20503.				
1. AGENCY USE ONLY (Leave blank)		2. REPORT DATE March 1997	3. REPORT TYPE AND DATES COVERED FINAL, Feb 95 - Feb 96	
4. TITLE AND SUBTITLE OPTICALLY ACTIVE MATERIAL CYLINDER FIBERS			5. FUNDING NUMBERS C - F30602-95-C-0052 PE - 62702F PR - 4600 TA - P4 WU - PK	
6. AUTHOR(S) Philipp Kornreich				
7. PERFORMING ORGANIZATION NAME(S) AND ADDRESS(ES) Syracuse University Department of Electrical and Computer Engineering Syracuse NY 13244			8. PERFORMING ORGANIZATION REPORT NUMBER	
9. SPONSORING / MONITORING AGENCY NAME(S) AND ADDRESS(ES) Rome Laboratory/OCPA 25 Electronic Pky Rome NY 13441-4515			10. SPONSORING / MONITORING AGENCY REPORT NUMBER RL-TR-96-254	
11. SUPPLEMENTARY NOTES Rome Laboratory Project Engineer: David J. Gruzca, OCPA, (315) 330-2105				
12a. DISTRIBUTION AVAILABILITY STATEMENT Approved for Public Release; Distribution Unlimited			12b. DISTRIBUTION CODE	
13. ABSTRACT (Maximum 200 words) During this reporting period we have learned a great deal about the process of fabricating fibers with optically active material stripes or cylinders located between the core and cladding. We have learned that in order for the optically active material layer covering the core rod to deform smoothly during the fiber fabricating process it is necessary for the glass to be very viscous while the optically active material layer must be soft at the fiber drawing temperature. This requires that the process be performed at a temperature much lower than the nominal softening temperature of the glass. The components of the preform deform by a factor of about one hundred during the fiber fabricating process. This is a very fabrication friendly technology. A large number of different devices can potentially be fabricated by this technology. We would like other laboratories to take on some of this exceedingly promising work.				
14. SUBJECT TERMS optical fiber, active optical fiber devices			15. NUMBER OF PAGES 24	
			16. PRICE CODE	
17. SECURITY CLASSIFICATION OF REPORT UNCLASSIFIED	18. SECURITY CLASSIFICATION OF THIS PAGE UNCLASSIFIED	19. SECURITY CLASSIFICATION OF ABSTRACT UNCLASSIFIED	20. LIMITATION OF ABSTRACT UNLIMITED	

ABSTRACT.

During this reporting period we have learned a great deal about the process of fabrication fibers with optically active material stripes or cylinders located between the core and cladding. We have learned that in order for the optically active material layer covering the core rod to deform smoothly during the fiber fabricating process it is necessary for the glass to be very viscous while the optically active material layer must be soft at the fiber drawing temperature. This requires that the process be performed at a temperature much lower than the nominal softening temperature of the glass. The components of the preform deform by a factor of about one hundred during the fiber fabricating process. This is a very fabrication friendly technology. A large number of different devices can potentially be fabricated by this technology. We would like other laboratories to take on some of this exceedingly promising work.

1 INTRODUCTION

During this reporting period we have learned a great deal about the process of fabrication fibers with optically active material stripes along the fiber core or cylinders surrounding the fiber core. We use these reports to summarize the current knowledge of fabricating fibers with optically active materials at the core cladding boundary. This appears to be a very fabrication friendly technology. A large number of different devices can potentially be fabricated by this technology. The fabrication processes of both the optically active materials such as metals, semiconductors, and magnetic materials and the glasses used here are well established. We have shown that many semiconductors and metals survive the below described fabrication processes. We would like other

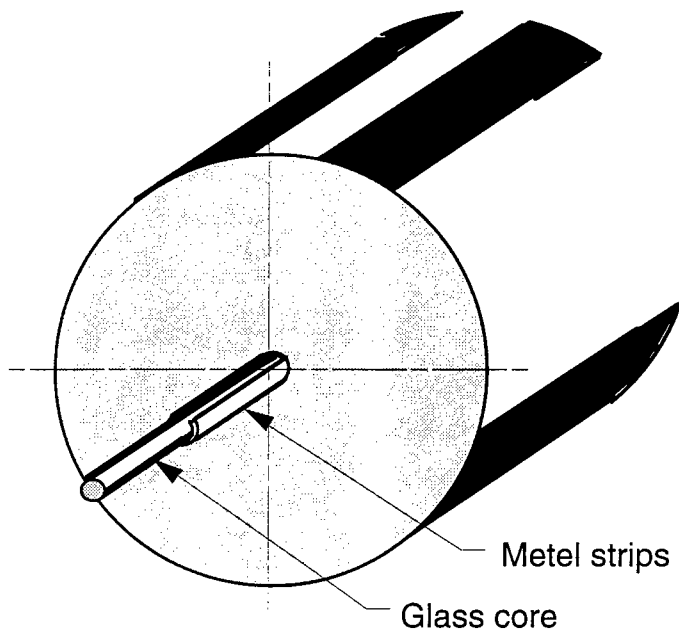

Fig. 1. Metal strip polarizing fiber with one or two metal strips along the fiber core.

laboratories to take on some of this exceedingly promising work. We have mainly been hampered by severe equipment problems rather than by problems that some of the fabricating processes do not work. For example, we assembled a vacuum system used for depositing the semiconductor

layers out of salvaged components which breaks down regularly. Some of these components date from the 1950's. It is increasingly more difficult to obtain specialty glass, stainless steel and other materials in the U. S. A. of the 1990's.

As described in several previous reports the preform used for fabricating these devices consist of a glass core rod on which one or more materials have been vacuum deposited and glass tubes that are collapsed onto this glass rod. Some or all the materials can form complete cylinders surrounding the glass core rod or cover only a portion of the core rod circumference.

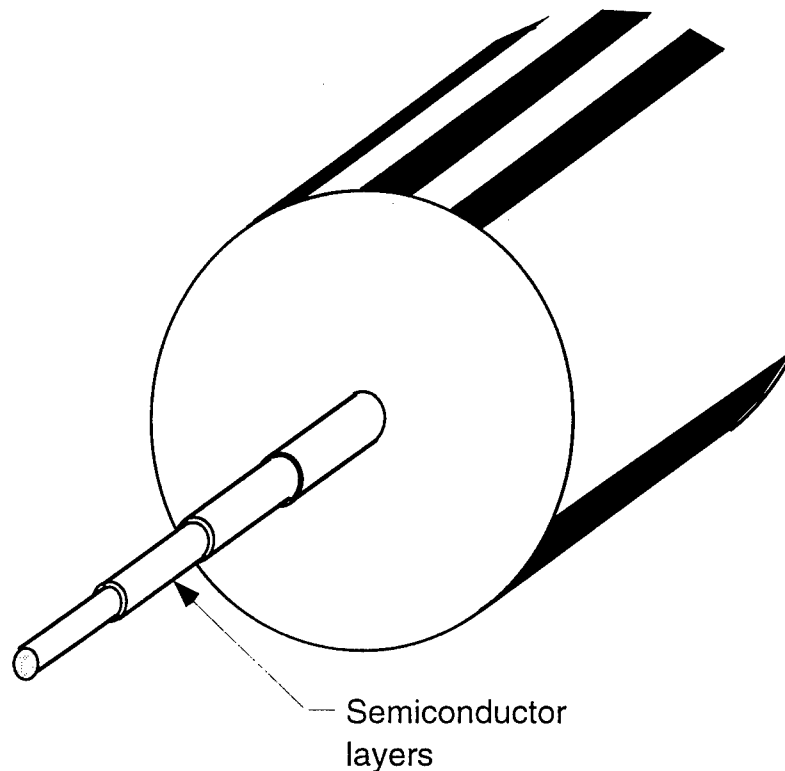

Fig. 2. Semiconductor Cylinder Fiber with several semiconductor layers surrounding the fiber core.

For metal strip fibers the melting point of the metal alloy can be matched to the glass. The melting point has to be high enough so that the metal does not melt during the collapsing process and low enough so that it is sufficiently soft and malleable at the fiber pulling temperature

while the glass is sufficiently viscous at the fiber pulling temperature to smoothly deform the metal layer during the fiber pulling process. All the components of the preform shrink by a factor of about one hundred during the fiber pulling process.

For semiconductor cylinder fibers the semiconductor materials are selected to have desirable optical properties. Thus, the melting point of the semiconductor layers are fixed and the softening temperature of the glass has to be matched to the semiconductor properties. The softening temperature of the glass has to be low enough so that the semiconductor layers don't melt during the collapsing process and high enough so that the semiconductor layers are sufficiently soft and malleable while the glass is sufficiently viscous at the fiber pulling temperature to smoothly deform the semiconductor layer during the fiber pulling process.

2 GLASS FABRICATION

At present we use 1 mm diameter type 7720 glass rods having a specified index of refraction of 1.487 and a measured the index of refraction of 1.4877 . The rod has a softening temperature of 755 °C. The four type 7052 glass tubes have a specified index of refraction of 1.484 and a measured index of refraction of 1.4812. The tubes have a softening temperature of 708 °C . The first tube has a minimum inside diameter of 1.9 mm (max. I. D. = 2.413 mm) and a maximum outside diameter of 6.35 mm (min. O. D. = 5.334 mm). The second tube has a minimum inside diameter of 7.3406 mm (max. I. D. = 8.9154 mm) and maximum outside diameter of 11.4554 mm (min. O. D = 10.3886 mm). The third tube has a minimum inside diameter of 12.3444 mm (max. I. D. = 14.0716) and a maximum outside diameter of 16.2052 mm (min. O. D. 15.2908 mm). The fourth tube has a minimum inside diameter of 16.4338 mm (max. I. D. = 18.5166 mm) and a maximum outside diameter of 20.955 mm (min. O. D. 19.5834 mm). The total cross section of the components of the preform is preserved in the collapsing process. Therefore the preform should have an average diameter of D_p :

$$D_p = [1 + (5.842^2 - 2.1565^2) + (10.922^2 - 8.131^2) + (15.748^2 - 13.208^2) + (20.2692^2 - 17.4752^2)]^{1/2}$$

$$D_p = 16.2068 \text{ mm}$$

This gives a ratio of the preform outside diameter to the core rod diameter of 16.2068. By using the measured indices of refraction values and requiring that the fiber let only a single mode propagate at a wavelength of $1.3 \mu\text{m}$, that is the V number is equal to 2.405 we obtain a fiber core diameter of $7.164 \mu\text{m}$ and a fiber outside diameter of $116.1 \mu\text{m}$. If one only uses three tubes the preform diameter D_p is:

$$D_p = [1 + (5.842^2 - 2.1565^2) + (10.922^2 - 8.131^2) + (15.748^2 - 13.208^2)]$$

$$D_p = 12.5381 \text{ mm}$$

This gives a ratio of the preform outside diameter to the core rod diameter of 12.5381. By using the measured indices of refraction values and requiring that the fiber let only a single mode propagate at a wavelength of $1.3 \mu\text{m}$, that is the V number is equal to 2.405 we obtain a fiber core diameter of $7.164 \mu\text{m}$ and a fiber outside diameter of $89.82 \mu\text{m}$.

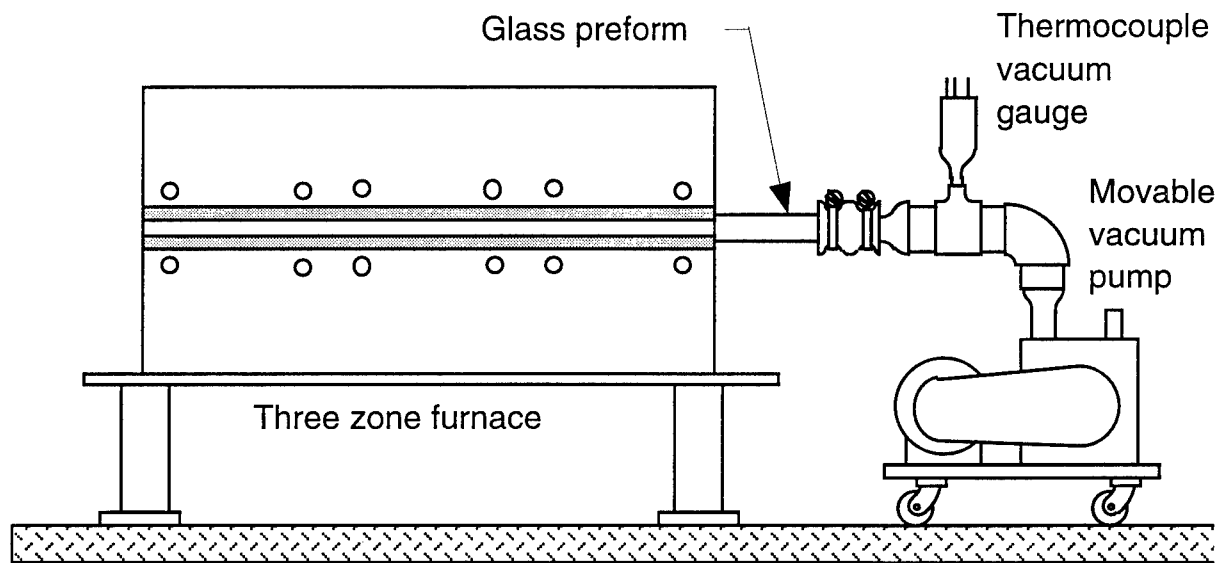

Fig. 3. Furnace for collapsing Pyrex type glass.

An experiment was carried out to see at what temperature one of the above glass tubes would sag under its own weight. The tube become strongly elliptical at 654 °C.

The tubes are collapsed sequentially. We use an electrical tube furnace schematically shown in Fig. 3 to collapse the tubes. We have arranged the temperature profile in a three zone furnace to have a gradient of about 20 °C. The furnace is schematically shown in Fig. 6. The furnace is hottest near the end facing away from the vacuum pump. A movable mechanical vacuum pump capable of a vacuum of 10^{-3} Torr is located near one end of the furnace. The glass tube to be collapsed is attached to the vacuum pump and the pump can be moved on caster wheels to insert the tube into the furnace. The heating elements of each of the three zones of the furnace are connected to a variable autotransformer or "Variac". The three Variacs have a common shaft so that the temperature in the furnace can be changed with a single control. The three Variacs are off set from each other to generate a temperature gradient of about 20 °C in the furnace. The furnace is equipped with three thermocouples for monitoring the temperature inside the furnace.

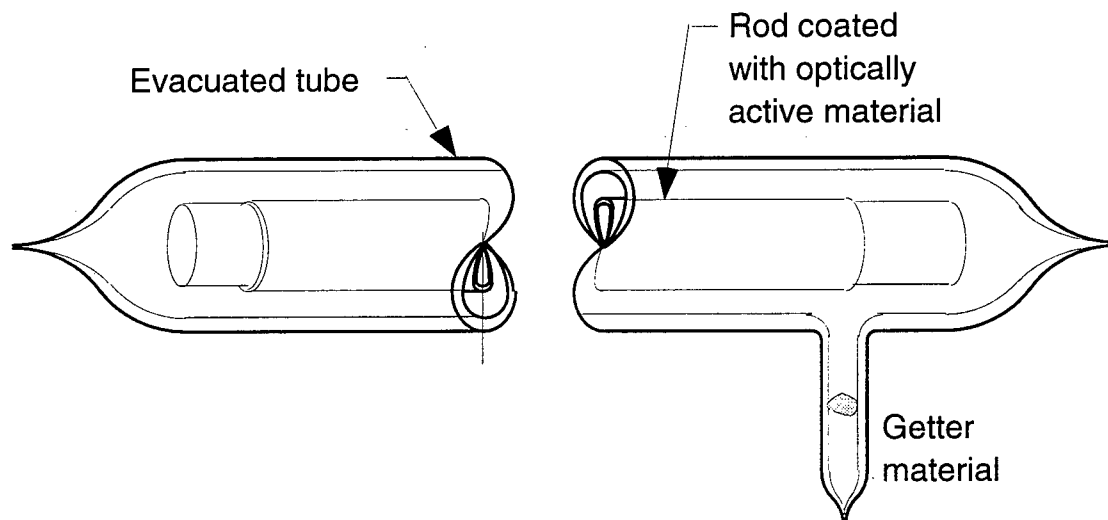

Fig. 4. If necessary the first tube that is to be collapsed onto the coated core rod can be evacuated to a vacuum of 10^{-9} to 10^{-10} Torr with the assistance of a geter as was done in the vacuum tube fabrication.

If it is necessary to prevent the oxidation of the optically active material the first tube that is to be collapsed onto the coated core rod can be evacuated to a vacuum of about 10^{-6} Torr and sealed. If a vacuum of 10^{-9} to 10^{-10} Torr is required a getter can be used in the tube as was done in the vacuum tube fabrication. This is schematically shown in Fig. 4. The getter material is heated by an external induction coil. The evacuated tube is collapsed in the same furnace as the tubes that are only evacuated to a 10^{-3} Torr vacuum.

We have constructed a 10 ft high tower out of "handy angle". A heater having a single loop filament with a stainless steel heat shield powered from a 22:1 (110 V to 5 V) heater transformer is located on top of the tower as shown in Fig. 5. The heater transformer is connected to a Variac located near the bottom of the tower. This heater is to be used for heating the preform to draw a fiber. A motorized translation stage capable of moving vertically a total of 4 inches is also located on top of the tower. The preform holder is attached to the translation stage as shown in Fig. 5.

This allows for lowering the preform into the fiber drawing heater. The translation stage can be moved at speeds varying from $18 \mu\text{m}$ to $180 \mu\text{m}$ per second. The translation stage is powered by a "Hybrid" 4/2 phase stepping motor with 5V, 1 Amp. per phase. The motor moves at 1.8° per step. Signals at frequencies varying from 1 to 10 Hz. are applied to the motor. A capstan will be located at the bottom of the tower. We should be able to draw about 1.5 km of fiber from a 15 mm diameter 10 cm long preform.

It is necessary for the material covering the core rod to have a melting point larger than the working temperature of the glass so that it will not melt during the collapsing process. On the other hand it has to be soft and malleable enough at the fiber drawing temperature to be deformed smoothly by the surrounding glass. The glass is very viscous so that it can deform the the optically active layer during the fiber pulling process. This requires that a substantial force be applied to the fiber during the fiber pulling process. Constant tensioning on the fiber can be maintained with the arrangement shown in Fig. 6. A potentiometer connected to the axis on which the lever arm pivots senses the motion of the weight and regulates the speed at which the capstan pulls the capstan pulls the fiber. The capstan is driven by a three phase stepping motor. The speed of the stepping

motor depends on the repetition rate of the pulses applied to the motor. The voltage from the potentiometer can be used to control the pulse repetition rate of a "Voltage Controlled Oscillator" that generates the clock pulses for the stepping motor circuit.

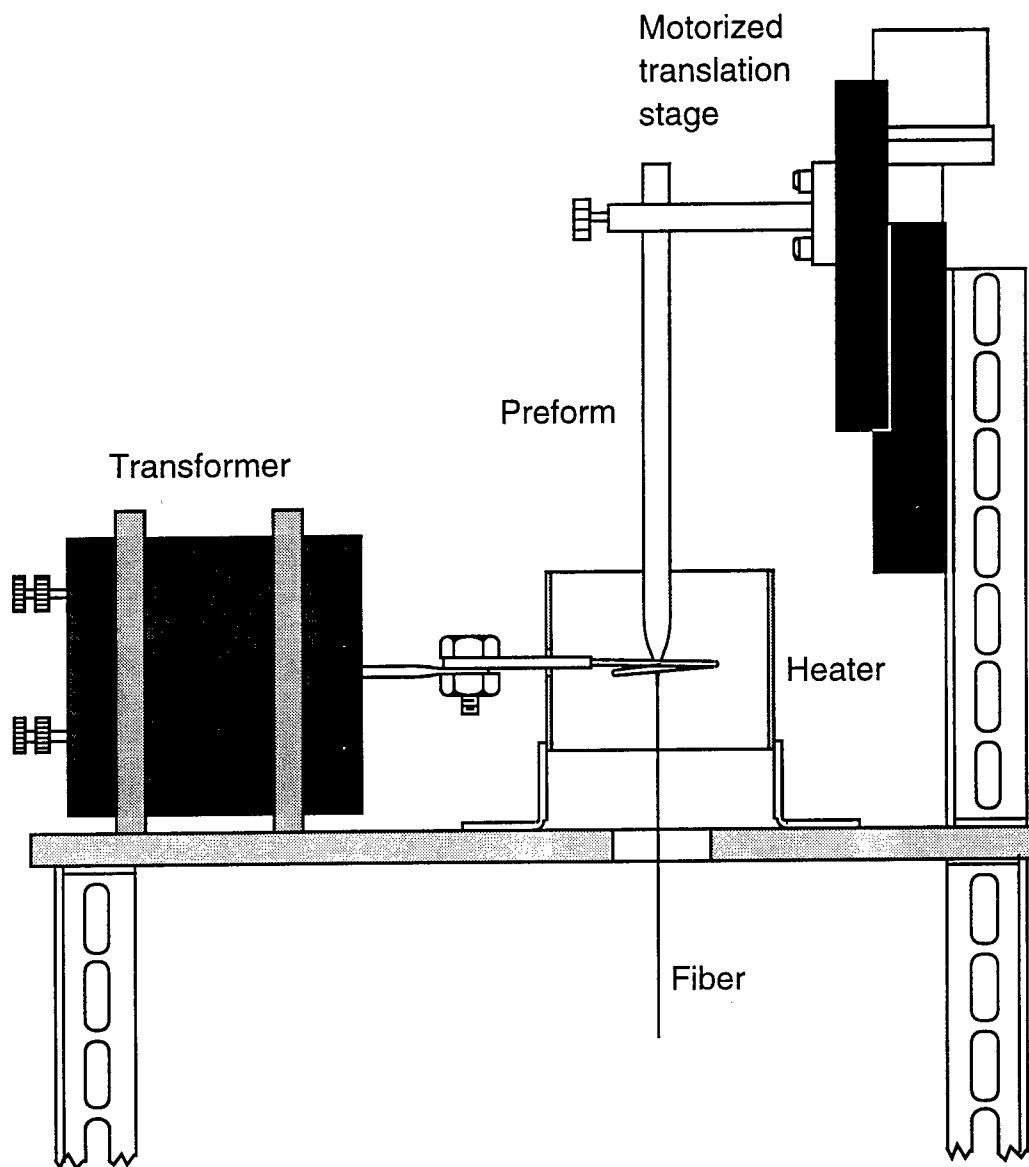

Fig. 5. Fiber drawing arrangement. A force is applied to the fiber by the arrangement shown in Fig. 6.

For glass that has to be worked at temperatures higher than about 900 °C we will use a hydrogen oxygen burner. This vertical glass lathe/fiber

drawing tower has a burner with eight torches. The torches can be moved in and out radially under computer control to control the temperature of the glass preform. The torch assembly rotates at about 25 RPM. The burner can be moved vertically at speeds ranging from 18 μm per second to about 10 cm per second. There is a three speed gear box that controls the

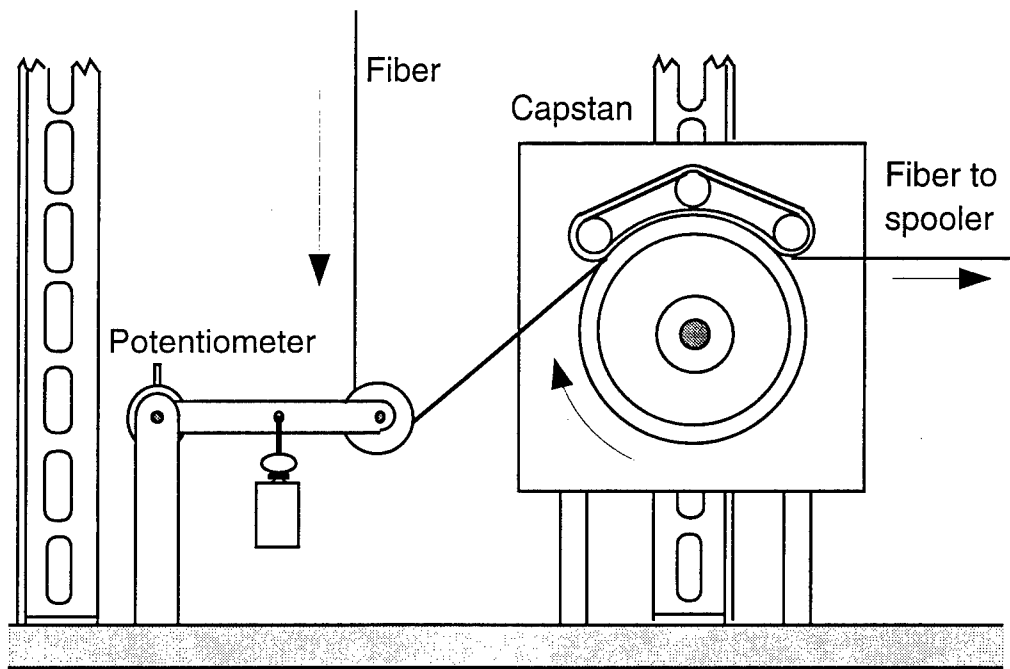

Fig. 6. A constant tension fiber pulling arrangement. A substantial tension is required to pull a fiber from the very viscous glass required for deforming the optically active material. A potentiometer connected to the axis on which the lever arm holding the weight pivots senses the motion of the weight and regulates the speed of the capstan.

vertical burner motion speed ranges. The vertical burner motion is computer controlled. The lowest speeds are used for raising the burner along the stationary preform during fiber drawing. This equipment has still to be installed.

The glass tube is clamped at the bottom and loosely held at the top during the collapsing process. A weight is attached to the top of the tube to prevent the structure from expanding too much. The glass rod is in-

serted into the first glass tube, the tube is evacuated. We use a circular gas burner. The gas flame is in contact with the outside surface of the glass. The glass is a poor heat conductor. Therefore, the glass is heated more at the outside than at the inside. The burner is first used to preheat the structure to a temperature below the working temperature of the glass so that both the glass rod and tube will start from the same temperature during the cooling process after the tube has been collapsed. This is done by propagating the burner along the glass tube. If this is not done either the tube or core rod will crack. After preheating the tube and rod the temperature of the tube is increased by bringing the burner flames closer to the glass tube. The tube is collapses by propagating the burner along the structure. This structure is inserted into the next tube and the process is repeated.

For The preform is heated at the lower end until a glob consisting of the lower portion of the preform drops and pulls a fiber behind it. At this point the burner is very slowly moved up along the preform and the preform temperature is lowered by pulling the burner flames away from the preform. If this is not done the burner will burn through the fiber. The fiber is pulled manually and attached to a spool while the temperature of the preform end is increased by bringing the flames closer to the preform again. The spool rotates and both pulls and spools the fiber. Because our tower is so low the fiber is still hot when it is spooled. It would burn a capstan. The spool is covered with metal foil to avoid burning.

The fiber has to be pulled at the lowest temperature possible. It is pulled by applying a mechanical force. The material surrounding the glass core rod must be soft and malleable at the fiber pulling temperature so that it will deform smoothly during this process. The material is deformed by the surrounding glass. Therefore, the glass can not be too soft during this process. If the glass is heated too much so that it becomes too soft, the material surrounding the core will tear.

3 METAL FABRICATION

Our first metal strip fibers used silver. These fibers had rather large cores so that a large number of mode could propagate in the fibers. The

metal interacts only weakly with the light. It is necessary for the fibers to have cores through which only a single mode propagates. The silver seems to deform fairly well in the fiber pulling process. However, Silver seems to also diffuse into the glass. We tried Cu next. However when we pulled a fiber from the Cu film preform the Cu tore, as shown in Fig. 7. Therefore, we use an AlCu alloy for the Metal Strip Polarizing Fibers. Cu has a melting point of 1086 °C and a density of 8.96 gr. per cm³. Al has a melting point of 660 °C and a density of 2.6989 gr. per cm³. The melting point of AlCu can be adjusted by selecting the appropriate Al and Cu composition. The AlCu alloy films are fabricated by first preparing the

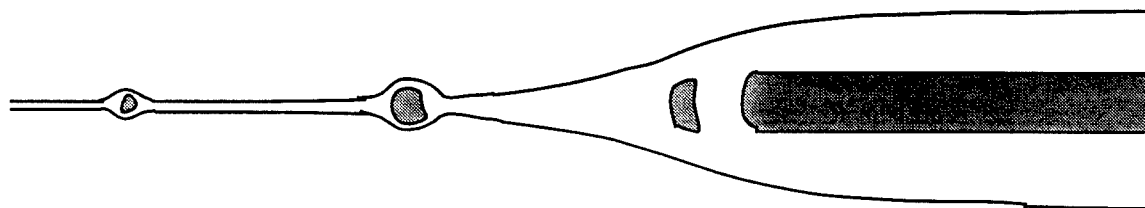

Fig. 7. The metal strip in the preform tears into large pieces during the fiber drawing process when the melting point of the metal is too large compared to the working temperature of the glass as was the case with Cu strips on type 7720 glass.

appropriate alloy by melting Cu and Al pieces in a crucible. A flux has to be added to the Al and Cu pieces to prevent oxidation during melting. Appropriate amounts of Cu and Al are selected to yield the desired alloy. The mixture is melted in a crucible and cast. The melt has to be protected by about 5 mm of carbon powder. The carbon serves as a reducing agent. Borax powder can be used as a flux. The melt has to be stirred during the melting process. Preferably, a carbon rod should be used for stirring. However, a steel rod can also be used. The Cu should be melted first and the Al should be added later. Part of this casting is used to test the melting point and malleability of the alloy while another portion is evaporated to form a film on the core rod. A diagram showing melting points of the alloy as a function of Cu concentration is shown in Fig. 8 and a phase diagram of the AlCu alloy is shown in Fig. 9. AlCu alloys with melting points ranging from 540 °C to 1084 °C. can be fabricated.

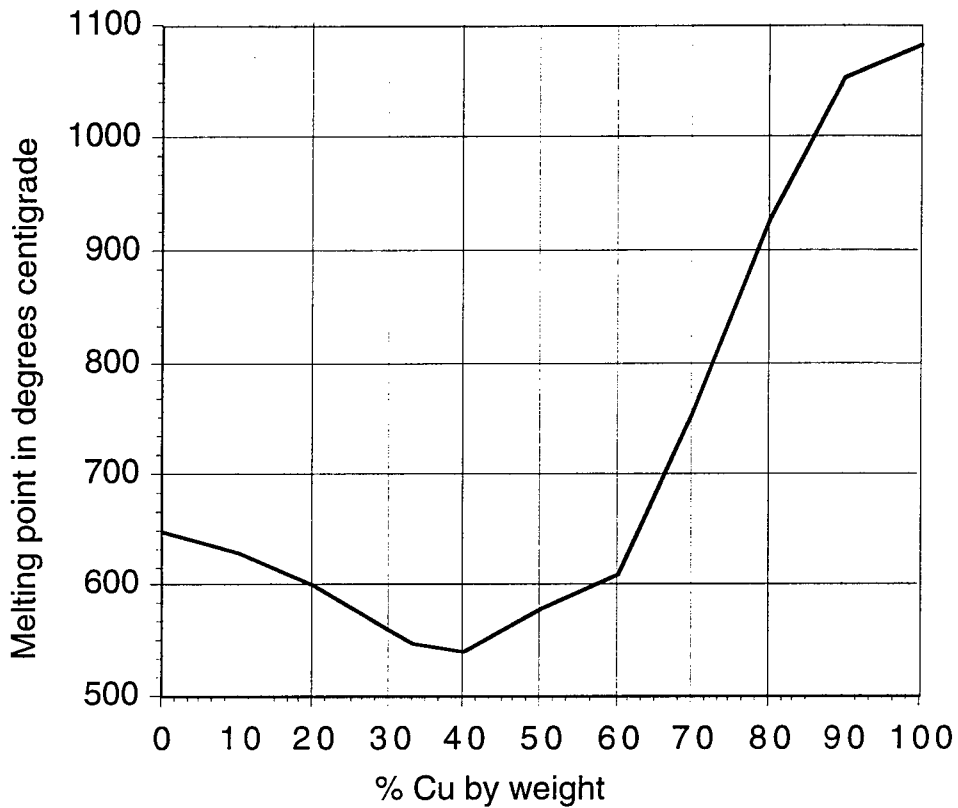

Fig. 8. Melting points of AlCu alloy as a function of Cu concentration by weight

Liquid solubility of Cu in Al by percent weight

Temperature in °C	660	700	750	800	850	900	950	1000
Solubility by weight % Cu	61	64	67	70	72	75	77	80

Eutectic 33.2 % Cu in Al. Eutectic temperature 548 °C.

Melting point of AlCu alloy for percent Cu by weight

T in °C	650	630	600	560	540	580	610	755	930	1055	1084
Wt. % Cu	0.0	10	20	30	40	50	60	70	80	90	100

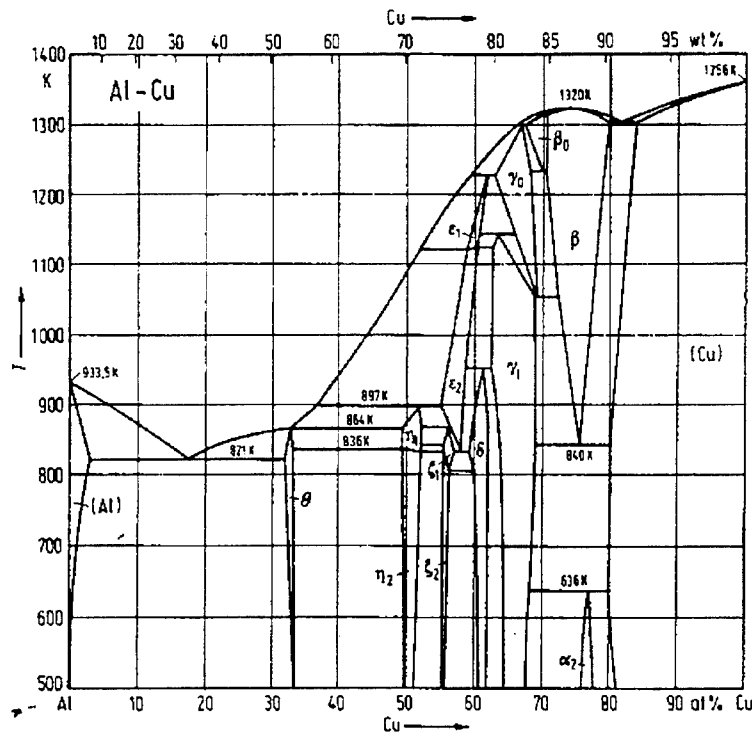

Fig. 9. Phase diagram of AlCu alloy. The percent Cu concentration by weight scale is at the top of the diagram. Note that the temperature scale is in degrees Kelvin.

We have fabricated AlCu alloy films from a melt containing 63.978 % Cu and 36.022 % Al by weight. The alloy has a melting point of about 720 °C. The alloy had a specific gravity of 4.9541 gr. per cm³. We have vacuum deposited these alloys on unheated 2 mm diameter type 7440 Pyrex glass rods. We have inserted these Pyrex glass rods with alloy metal strips into glass tubes, evacuated the glass tubes and collapsed the tubes. The furnace had a temperature gradient of 20 °C. We first collapsed a 3 mm I. D. tube onto the rod, and next collapsed a larger tube onto the first tube. This resulted in a 6.25 mm diameter preform.

The vacuum deposited film had a few pin holes. No new pin holes were added during the collapsing process. When viewed from the bottom (through the glass rod) the films appeared to have dark and shiny areas after collapse. We also fabricated metal alloy strips on 2 mm diameter Pyrex glass rods that had three layers; an In layer deposited on the glass rod followed by a thicker alloy layer, followed by an In covering layer.

These films when collapsed were metallic gray on both sides after collapse.

4 SEMICONDUCTORS FABRICATION

A vacuum system with four computer controlled sources is used to for depositing the semiconductor layers on three rotating glass rods. Each source consists of a fixed oven and a removable quartz container holding the semiconductor powder as shown in Fig. 10. Fresh containers of

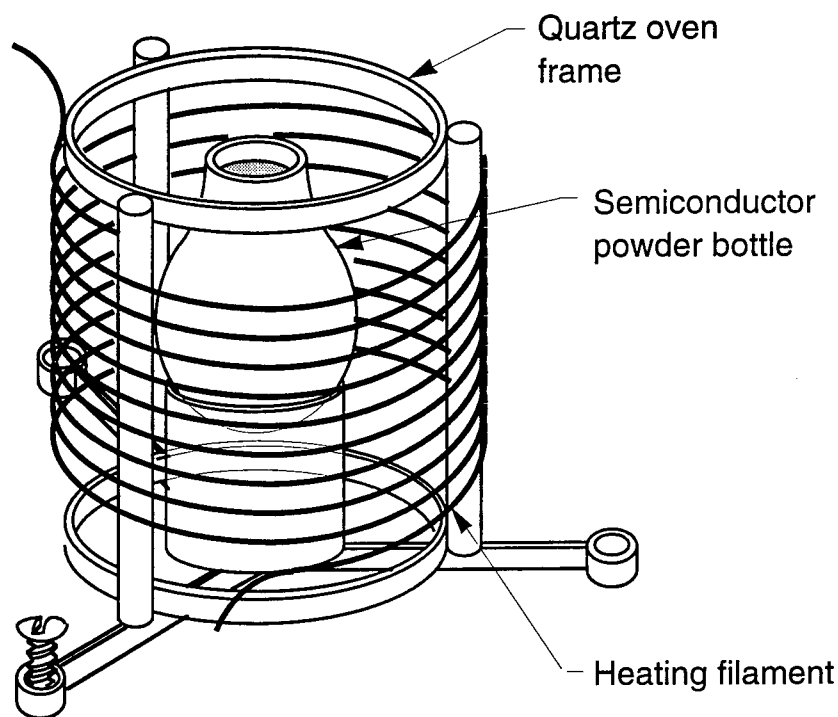

Fig. 10. Effusion cell with removable semiconductor powder container, heat shield not shown.

semiconductor powders are used for each deposition run. The appropriate ternary semiconductor materials are prepared by codepositing two binary semiconductors. Two sources are used at a time to deposit a three component semiconductor such as $\text{InSb}_{1-x}\text{P}_x$. One effusion source would contain InP while the other source contains InSb . The effusion sources must be calibrated by depositing each binary semiconductor compound at different temperatures for the same time duration and measuring the thickness of

the resulting films. This will give the approximate deposition rate of each semiconductor compound as a function of temperature. These calibration can serve as a starting point for depositing the three component semiconductor compound. The temperature of each source will than be adjusted to give a semiconductor compound with the desired energy gap. The source temperatures are controlled.

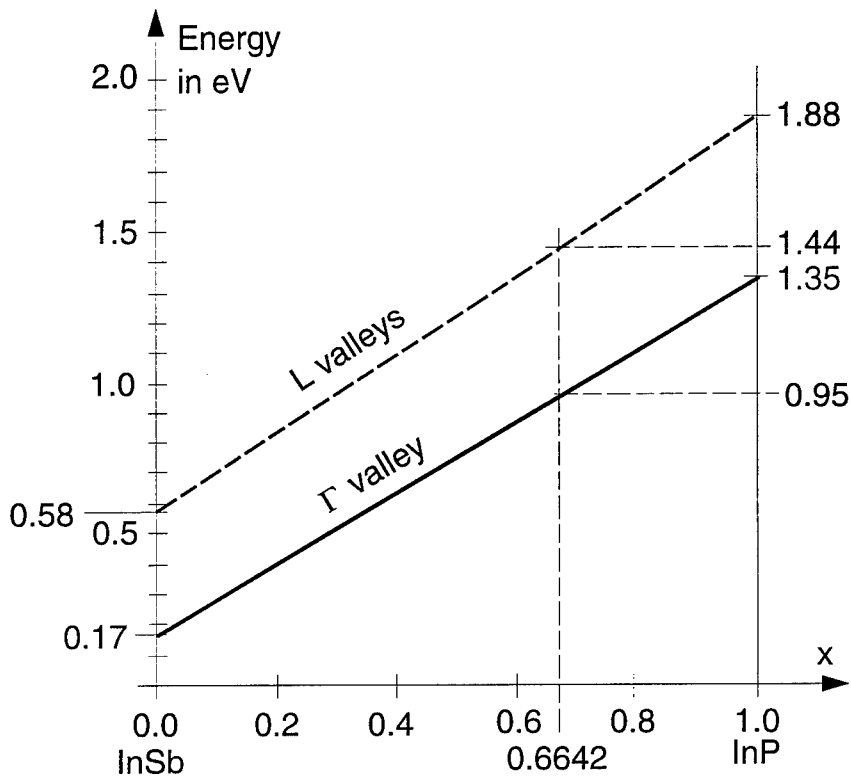

Fig. 11. Energy gap for $\text{InSb}_{1-x}\text{P}_x$ semiconductor compound as a function of the molar concentration x .

The rotating core glass rods are heated during deposition by Halogen lamps. All semiconductor layers are grown consecutively without opening the vacuum system. The properties of the semiconductors change during the collapsing process. The collapsing process appears to anneal the semiconductors. Past experience with CdS fiber preforms have shown that the collapsing process improves the sharpness of the absorption curve of CdS. The absorption and luminescence spectrums of the semiconductor structures in the preform will be measured to determine if the semiconductors

have the properties necessary for device operation. The melting point of the various semiconductor layers will have to be measured.

An appropriate semiconductor material to be used with the Pyrex type glasses is $\text{InSb}_{1-x}\text{P}_x$.

Martial	Energy gap in eV	Melting Point in °C	Crystal structure	Lattice constant in Å
InSb	0.17	535	Zincblende	6.4794
InP	1.35	1070	Zincblende	5.8686
AlSb	1.58	1058	Zincblende	6.1355

A quaternary compound such as $\text{Ga}_{0.27}\text{In}_{0.73}\text{As}_{0.63}\text{P}_{0.37}$ is often used in the fabrication of semiconductor lasers. The reason for this is that not only does the energy gap need to be tailored for the device to operate at the desired wavelength but the semiconductor layer has to be lattice matched to the InP wafer substrate. In our case the buffer layer has to have a melting point, crystal structure, and lattice constant similar to the active $\text{InSb}_{1-x}\text{P}_x$ layer. The buffer layer must, also have an energy gap that is larger than the energy gap of the active layer.

The semiconductors materials InP and InSb used in the $\text{InSb}_{1-x}\text{P}_x$ compound have the following properties: Both semiconductors are of the direct gap type. It appears from the literature that the energy gap in these type semiconductors varies linearly with composition as shown in Fig. 10. For a possible Semiconductor Cylinder Fiber light Amplifier (SCFLA) working at a wavelength of $1.3 \mu\text{m}$ an active semiconductor layer having an energy gap of 0.9537 eV would be required. Assuming a linear relation between the direct energy gap as a function of composition as shown in Fig. 10 a molar concentration x of 0.6642 of P would be required.

An additional feature of a SCFLA using $\text{InSb}_{0.3358}\text{P}_{0.6642}$ is that it might be possible to pump these devices with a GaAs laser operating at a wavelength of $0.86 \mu\text{m}$ which would generate electrons in the "L" valleys. These electrons would quickly scatter into the central Γ valley. This would be a three level lasing or light amplifying device. $\text{InSb}_{0.3358}\text{P}_{0.6642}$ has an estimated lattice constant of 6.0737 Å. This could readily be matched to an AlSb buffer layer with a lattice constant of 6.1355 Å and an

energy gap of 1.58 eV. However, the melting point of AlSb is somewhat high. We might have to look for a better buffer layer material (as of May 1996).

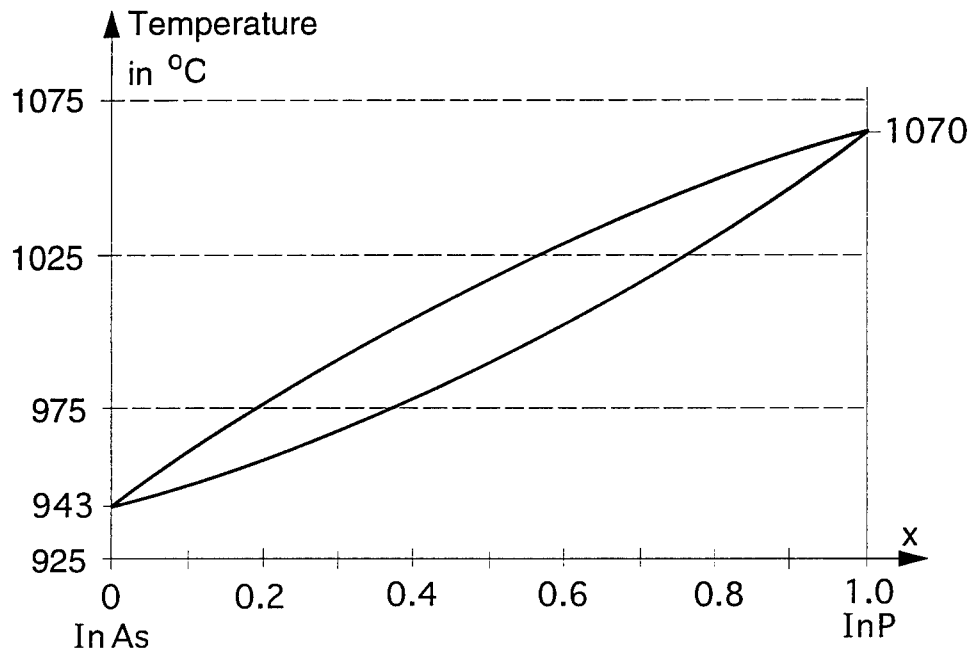

Fig. 12. Phase diagram of $\text{InAs}_{1-x}\text{P}_x$ semiconductor compound from Landolt Börnstein "Zahlenwerte und Funktionen aus Naturwissenschaften und Technik" Band (volume) 17, Seite (page) 633, Springer Verlag Berlin, Heidelberg, New York.

For example the phase diagram of the $\text{InAs}_{1-x}\text{P}_x$ semiconductor compound as shown in Fig. 12 appears to have a more or less linear relation between the molar concentration of P and the melting point of the material. If we use a similar linear approximation for the melting point of $\text{InSb}_{1-x}\text{P}_x$ as a function of the molar concentration of P, we obtain for a molar concentration $x = 0.6642$ of P a melting point of about 890 °C. This would require a glass with a nominal softening point of 970 °C which we would then form at 870 °C.

***MISSION
OF
ROME LABORATORY***

Mission. The mission of Rome Laboratory is to advance the science and technologies of command, control, communications and intelligence and to transition them into systems to meet customer needs. To achieve this, Rome Lab:

- a. Conducts vigorous research, development and test programs in all applicable technologies;
- b. Transitions technology to current and future systems to improve operational capability, readiness, and supportability;
- c. Provides a full range of technical support to Air Force Material Command product centers and other Air Force organizations;
- d. Promotes transfer of technology to the private sector;
- e. Maintains leading edge technological expertise in the areas of surveillance, communications, command and control, intelligence, reliability science, electro-magnetic technology, photonics, signal processing, and computational science.

The thrust areas of technical competence include: Surveillance, Communications, Command and Control, Intelligence, Signal Processing, Computer Science and Technology, Electromagnetic Technology, Photonics and Reliability Sciences.