

RIA-78-U325

Technical Paper 1256

TECHNICAL
LIBRARY

Role of Alloying Elements in Adhesive Transfer and Friction of Copper-Base Alloys

Donald H. Buckley

DISSEMINATION STATEMENT A

Approved for public release;
Distribution Unlimited

JUNE 1978

19971014 159

DTIC QUALITY INSPECTED 3

NASA

ROLE OF ALLOYING ELEMENTS IN ADHESIVE TRANSFER
AND FRICTION OF COPPER-BASE ALLOYS

by Donald H. Buckley

Lewis Research Center

SUMMARY

An investigation was conducted to determine the influence of alloying elements on the friction and adhesive transfer of copper-base alloys in contact with a bearing steel. Riders of the copper-base binary alloys were made to slide in a vacuum against a steel disk surface under a load of 100 grams and at a sliding velocity of 60 millimeters per minute. Transfer of the copper alloy to the bearing-steel surface was monitored with Auger spectroscopy analysis. Sliding was continued for a total of 250 repeated passes.

There appears to be direct relation between the chemical stability of the oxide of the alloying element and adhesive transfer of the copper alloy to the oxide-containing steel surface. The more stable the oxide, the greater the adhesive transfer. A relation between reaction potential and adhesive transfer was also observed. The more chemically active the metal, the greater the transfer. With the exception of the copper-gold alloy, all copper-base alloys transferred to the oxide-containing steel surface in relatively few (25) passes.

INTRODUCTION

The chemical activity of metals in the elemental state, that is, their reaction potential, has been shown to influence adhesion, friction, and adhesive wear for these metals in contact with themselves, other metals, and nonmetals (refs. 1 to 3). Although the basic concept is fundamentally very useful, most practical lubrication systems contain not elemental metals but alloys. Therefore, how the elements in an alloy affect its adhesion, friction, and wear behavior is a matter of interest.

Copper-base alloys are some of the oldest and most widely used for bearing applications. A host of elements have been alloyed with copper for the purpose of achieving good bearing materials (ref. 4). However, the exact role of these alloying elements in the tribological behavior of copper has never been clearly understood (ref. 5).

The objective of the present investigation was to examine the influence of various alloying elements in copper on its friction and adhesive wear behavior when in contact with a conventional bearing-steel surface. One atomic percent of each alloying element was incorporated in copper. Simple binary alloys were selected for study to isolate the influence of a single alloying element on friction and transfer behavior. A 1-atomic-percent composition was chosen to determine the effect of even small concentrations of an alloying element on the friction and transfer characteristics of the host metal. Rider-on-disk experiments were conducted with the copper binary alloys sliding on the bearing steel. Cylindrical-mirror Auger spectroscopy analysis was used to monitor the transfer of the copper alloys to the bearing steel. Friction experiments were conducted at a sliding velocity of 60 millimeters per minute, with a load on the rider of 100 grams, and for a total of 250 repeated passes over the same surface. Residual surface oxides were present on the steel disk surface and no attempt was made to remove these oxides before the tests.

MATERIALS

The disks used in this study were standard AISI 52100 bearing-steel disks. Only two disks were used and they were refinished. They were from the same heat of steel (Rockwell hardness C-60).

The rider specimens were copper and binary copper alloys containing 1 atomic percent of various alloying elements. The elements alloyed with copper were magnesium, aluminum, silicon, manganese, gallium, zinc, tin, indium, nickel, germanium, antimony, palladium, platinum, silver, and gold. The alloys were prepared by furnace melting charges of the elements with copper in graphite crucibles under an argon atmosphere.

EXPERIMENTAL APPARATUS AND PROCEDURE

Experimental Chamber

The experiments were conducted in a vacuum chamber (fig. 1). The vacuum system was pumped by sorption pumps and an ion pump. Pressure in the vacuum system was read with a cold-cathode, trigger-discharge ionization gage.

Specimens

The friction and wear specimens consisted of a disk specimen 6.5 centimeters in diameter and 1.2 centimeters in thickness and a hemispherical rider 2.5 centimeters

in radius. The specimens are shown in figure 1. The disk specimen was mounted on a drive shaft that was rotated with a magnetic drive assembly. The drive assembly provided rotation at various speeds (in this study, 60 mm/min at the rider contact). The rider specimen was mounted in an insulated holder at one end of a stainless-steel shaft. Friction and wear experiments were conducted with the rider specimen loaded against the disk surface. As the disk was rotated, the rider scribed a circular wear track on the flat surface of the disk. The load used in this investigation was 100 grams, and the specimen temperature was 25^o C.

Measurements

The friction force between the disk and rider specimens was continuously recorded during the experiment. The beam containing the rider specimen was welded in a bellows assembly that was gimbal mounted to the vacuum system. The gimbal mounting permitted deadweight loading of the rider against the disk surface (fig. 1). Because it was at right angles to the deadweight loading, the beam containing the rider could move in two directions in the horizontal plane. Movement of the rider (with the disk as it rotated) was restrained by a cable that was attached to a temperature-compensated strain gage. This gage measured the frictional force between the disk and the rider specimen. The friction force was recorded on a strip chart.

Specimen Preparation and Cleaning

The disk specimens were finish ground on metallurgical papers to a grit of 600. They were then diamond polished with 6-micrometer and finally 3-micrometer, diamond paste. The disks were rinsed with acetone and then with absolute ethyl alcohol.

The rider specimens were acid etched before use with aqua regia to remove strained metal. They were then scrubbed with levigated alumina and rinsed in water and finally in ethyl alcohol.

Auger Analysis

Elemental analysis of the disk specimen surface could be made before, during, and after the friction and wear experiment by using an Auger cylindrical-mirror analyzer with an integral electron gun. The point of rider-to-disk contact passed under the Auger beam 12 seconds after that point had moved out of the contact zone. The Auger analyzer is a commercial unit, the essential elements of which are described in reference 6.

The primary beam of electrons was directed at the disk surface by a beam from

the electron gun in the Auger cylindrical-mirror analyzer. The beam was focused on the wear track scribed by the rider in sliding contact with the disk. The beam contact was 180° away from the rider on the disk surface, and the beam spot diameter was 0.2 millimeter. The gun contained deflection plates that allowed the beam to be positioned on the disk surface.

The secondary electrons came off the specimen surface, passed through the outer cylindrical can opening, and then passed through slits in an inner cylinder that served as an energy analyzer. They were collected by the electron multiplier. Elements were identified by analyzing the detected secondary-electron energies. The Auger electrons that appear in the secondary-electron distribution chemically identify the surface elements to a depth of approximately four atomic layers.

Auger traces were plotted on an x-y recorder. The surfaces were examined before, during, and after sliding. The Auger spectrometer contained a sample scanning positioner by which the wear trace was magnified and displayed on a television monitor and by which the beam of the electron gun was directed into the selected wear contact zone. Each data point acquired for Auger peak intensities consisted of three measurements in different regions of the wear track.

RESULTS AND DISCUSSION

Auger Analysis of Transfer

The bearing steel (AISI 52100) used in this study was not sputter cleaned in vacuum before the sliding friction experiments and thus contained normal oxides. It was the intent of this study to determine if transfer could occur onto such natural oxide films and how the alloying elements in the copper would affect that adhesive transfer.

An Auger spectrum of the steel surface before sliding is presented in figure 2(a). Auger peaks were detected for carbon, oxygen, and iron - a fairly typical spectrum of a steel surface - before each experiment in this investigation. The oxygen comes from adsorbed films and iron oxides on the surface.

A typical Auger spectrum after 250 passes of a binary copper alloy sliding against the bearing-steel surface is presented in figure 2(b). The spectrum is for an alloy of 1-atomic-percent nickel in copper. In addition to the Auger peaks for carbon, oxygen, and iron, there are three Auger peaks that result from the transfer of copper to the steel surface. Nickel, probably because of its small concentration in the alloy, was not detected although with some alloys the solute element was detected on the steel surface after sliding.

It should be noted in figure 2(b) that, although there is an attenuation of the oxygen peak height intensity relative to the the iron peaks, considerably oxygen is still present.

Since the carbon peak also undergoes attenuation, the attenuation of oxygen may be due to the desorption of adsorbed gases such as carbon monoxide, which may occur with sliding.

An iron and a copper peak were selected as a basis for determining the relative amount of copper-alloy transfer to the steel surface. The peaks selected are in figure 2(b). They will be used in subsequent figures as the ratio $I_{\text{Cu}}/I_{\text{Fe}}$. Although, with the copper rider, the amount of copper transferred to the steel surface was appreciable and visible to the naked eye after 250 passes, it was difficult to detect after only a few passes without the aid of Auger analysis.

Copper-Gallium and Copper-Platinum Alloys

Sliding friction experiments were conducted with riders of copper and binary copper alloys containing 1-atomic-percent gallium and platinum. Copper was selected as the reference material, the copper-gallium alloy was selected because it contains a highly chemically active element, and the copper-platinum alloy was selected because it contains a relatively chemically inactive element. The coefficients of friction and relative Auger peak intensities for these rider materials as a function of the number of repeated sliding passes are presented in figure 3.

In figure 3(a) the chemically active metal gallium in copper results in the highest measured friction coefficients. On the contrary, the relatively chemically inactive platinum in copper results in the lowest measured friction coefficients. Copper, as the reference, lies between the two alloys. The transfer of copper from the two alloys (adhesive wear) is shown in the Auger spectroscopy data of figure 3(b). As with the friction coefficient the greatest transfer is with the gallium alloy and least with the platinum alloy, with copper being intermediate.

Copper-Silicon, Copper-Manganese, and Copper-Palladium Alloys

Sliding friction experiments were also conducted with binary-copper-alloys riders containing 1-atomic-percent silicon, manganese, and palladium. The results are presented in figure 4. The friction coefficients for the silicon alloy were initially higher than those for the palladium and manganese alloys, which were nearly the same. After 125 passes, however, the friction coefficients for the three alloys were essentially the same (fig. 4(a)).

The amount of alloy transfer to the bearing-steel surface is greatest for silicon after 250 passes, intermediate for manganese, and least with palladium - the least chemically active of the three elements. The data of figure 4 reveal the potential pitfalls in attempts to correlate friction with adhesive wear.

Copper-Nickel, Copper-Indium, and Copper-Antimony Alloys

The coefficients of friction and relative adhesive transfers for binary copper alloys containing 1-atomic-percent indium, nickel, and antimony are presented in figure 5. With indium in copper, no further increase of copper on the steel surface or of friction was detected after 125 passes. Again, friction and adhesive wear cannot be correlated because of the results for antimony in figure 5.

Copper-Aluminum, Copper-Silicon, and Copper-Gold Alloys

The coefficients of friction and the relative adhesive transfers for binary copper alloys containing 1-atomic-percent aluminum, silver, and gold are present in figure 6. The Auger data indicate a relation between chemical activity and adhesive transfer to the steel surface. The very active aluminum alloy transfers very rapidly (fig. 6(b)), the silver alloy transfers more slowly, and the gold alloy required 100 passes before copper was detected on the steel surface.

Copper-Zinc Alloys

All the copper-base alloys described heretofore contained only 1-atomic-percent of the alloying element. To determine if increased concentrations of the alloying element in the solvent copper would further alter friction and transfer characteristics, we tested binary copper alloys containing 1- and 15-atomic-percent zinc. Zinc was selected because of the commercial importance of brass.

Friction and adhesive transfer data for these two copper-zinc alloys are presented in figure 7. The presence of zinc in copper markedly reduced the friction coefficient for copper sliding on steel. The friction differences in the data of figure 7(a) are appreciable: with the higher concentration of zinc the friction was much lower. Although after 25 passes friction (fig. 7(a)) increased markedly for the 1-atomic-percent copper-zinc alloy, there was only a gradual increase in the adhesion of this alloy to the steel surface (fig. 7(b)) with repeated passes. Up to 250 passes a greater amount of the 15-atomic-percent copper-zinc alloy transferred to the steel surface than the 1-atomic-percent alloy. At 250 passes the amount of transferred copper detected with both alloys was the same. Thus, only the rate of transfer to 250 passes was affected by the larger zinc concentration.

Comparison of Alloys

The term "chemical activity" has been used in the discussion of the foregoing data figures. But why do copper alloys undergo chemical reaction at the interface? Because all the Auger traces obtained after 250 passes with the copper alloys contained a very strong oxygen peak (fig. 2(b)), iron oxide must still be present at the interface. Therefore the adhesion of the copper alloys must be to the iron oxide. The chemical reactions of copper to iron oxide and of the alloying elements to iron oxide are then of importance.

The reactivity of a metal is indicated by its reaction potential and, if that metal interacts with oxygen or oxides, by the strength of the bond formed. Bond strength is gaged by the free energy of formation of the metal oxide and the decomposition temperature of that oxide. Some reaction potentials, free energies of oxide formation, and oxide decomposition temperatures for the metals alloyed with copper in this investigation are presented in table I. The values for copper are also included in table I for reference purposes.

When the relative copper-to-iron Auger peak intensities from figures 2 to 7 for the various elements alloyed with copper were plotted as a function of reaction potential, the data of figure 8 were obtained. With the very reactive copper-aluminum alloy, a large amount of adhesive transfer occurred; but, with the relatively chemically inactive copper-gold alloy, the amount of transfer was less than one-third that measured with the copper-aluminum alloy.

When the interaction of the copper alloys with the iron oxide of the bearing steel was considered and the relative Auger peak intensities of figures 2 to 7 were plotted as a function of oxide formation for the elements alloyed in copper, the data of figure 9 were obtained. These data show that there is a direct relation between the amount of copper alloy transferred and the chemical stability of the oxide of the alloying element. The less thermodynamically stable the oxide of the alloying element in the copper, the less adhesive transfer was observed.

The data of figure 9 reveal that the reaction of chemical activity of the alloying element in copper in concentrations as low as 1 atomic percent can profoundly influence adhesive transfer at the interface. The elements that are very reactive with oxygen - such as silicon, aluminum, and gallium - promote adhesive transfer and wear. In contrast, elements that are relatively inactive with oxygen - such as the platinum metals - do not promote adhesive transfer. In fact, platinum and palladium inhibited adhesive transfer, as indicated by their positions and that of elemental copper in figure 9.

Figure 9 shows the direct relation between the nature of the alloying element in copper and adhesive wear. These results emphasize the importance of alloy chemistry

even in concentrations of as little as 1 atomic percent. The stronger the interfacial bond of the alloying element to the iron oxide, the greater is the adhesive transfer of the bulk alloy.

Other Alloys

Friction and transfer studies were also conducted with binary copper alloys containing 1-atomic-percent magnesium and germanium. The results were markedly different, however, from those observed with the other alloy systems. For example, the magnesium alloy left a white transfer film of magnesium oxide on the steel disk surface. Apparently, sufficient surface segregation of magnesium resulted from sliding and the magnesium oxide formed. Its presence inhibited transfer of this copper alloy to the bearing-steel surface.

Even though the data obtained for copper containing 1-atomic-percent tin were limited, they are also presented in figure 9.

CONCLUSIONS

Sliding friction experiments were conducted with binary-copper-alloy riders containing 1-atomic-percent alloying element sliding on a conventional-bearing-steel disk. The following conclusions were drawn:

1. There is a direct relation between the free energy of formation of the oxide of the alloying element and the adhesive transfer of the alloy to the bearing-steel surface. The more stable the oxide, the greater is the adhesive transfer, or wear.
2. There is also relation between the reaction potential of the alloying element and the adhesive transfer of the alloy. The more reactive the metal, the greater is the adhesive transfer, or wear.
3. With all the alloys examined except copper-gold, adhesive transfer was detected after relatively few (25) repeated passes over the same surface.

Lewis Research Center,
National Aeronautics and Space Administration,
Cleveland, Ohio, March 29, 1978,
506-16.

REFERENCES

1. Buckley, Donald H.: The Metal-to-Metal Interface and Its Effect on Adhesion and Friction, *J. Colloid Interface Sci.*, vol. 58, no. 1, Jan. 1977, pp. 36-53.
2. Miyoshi, Kazuhisa, and Buckley, Donald H.: Friction and Wear of Single-Crystal and Polycrystalline Manganese-Zinc Ferrite in Contact with Various Metals. NASA TP-1059, 1977.
3. Miyoshi, Kazuhisa; and Buckley, Donald H.: Friction and Metal Transfer for Single-Crystal Silicon Carbide in Contact with Various Metals in Vacuum. NASA TP-1191, 1977.
4. ASM, Metals Handbook. 1948 ed., American Society for Metals, Cleveland, Ohio, 1948, pp. 752-754.
5. Kragelskii, Igor V.: Friction and Wear. Butterworths, 1965, p. 327.
6. Harris, L. A.: Analysis of Materials by Electron Excited Auger Electrons. *J. Appl. Phys.*, vol. 39, no. 3, Feb. 1968, pp. 1419-1427.

TABLE I. - REACTION POTENTIAL, FREE ENERGY OF OXIDE
 FORMATION, AND OXIDE DECOMPOSITION FOR VARIOUS
 METALS AND METAL OXIDES

Metal	Reaction potential ($m^0 \rightarrow m^+$), V	Free energy of oxide formation at 300 K		Oxide decomposition temperature, °C
		kJ/mole	kcal/mole	
Mg	2.34	567	-135	2770
Al	1.67	525	-125	2050
Si	-----	412	-98	1610
Mn	1.05	361	-86	-----
Ga	-----	328	-78	1725
Zn	.762	315	-75	-----
Sn	.140	256	-61	1100
In	-----	244	-58	-----
Ni	.236	231	-55	-----
Ge	-----	223	-53	-----
Sb	-----	202	-48	1080
Cu	-.340	126	-30	1100
Pd	-----	55	-13	-----
Pt	-----	34	-8	-----
Ag	-.7995	13	-3	185
Au	-1.42			-----

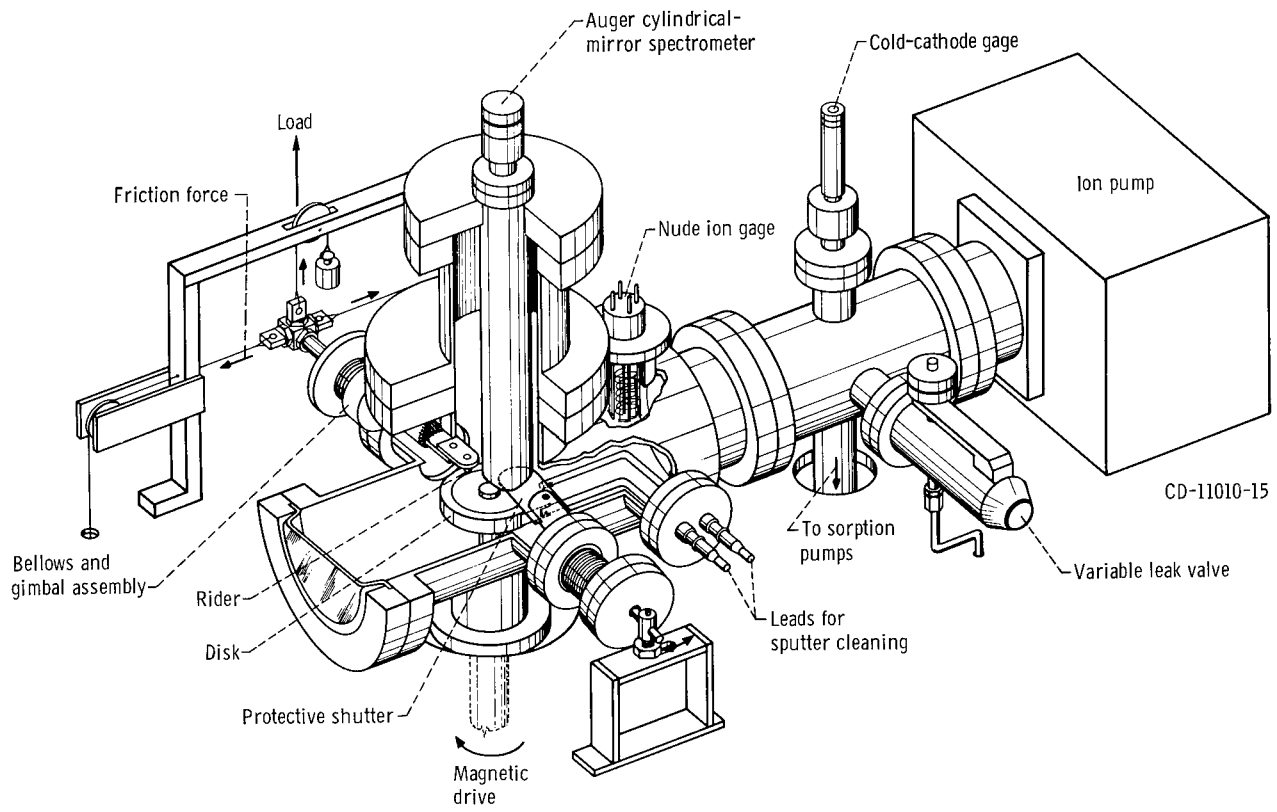
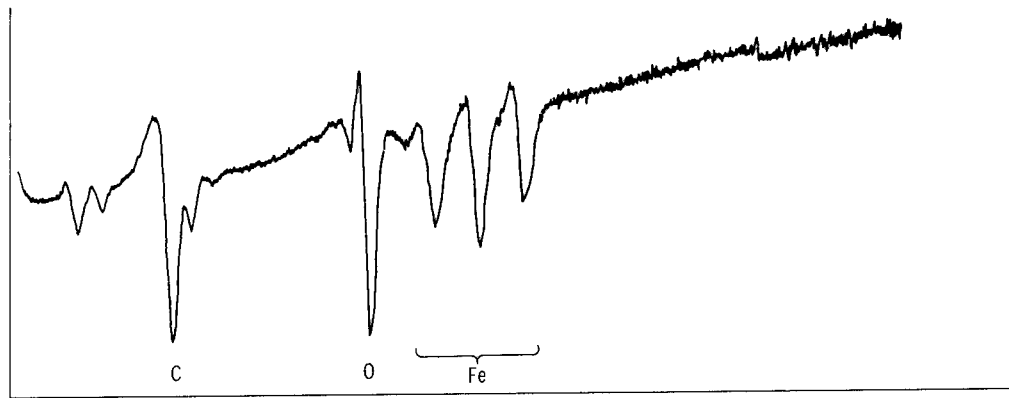
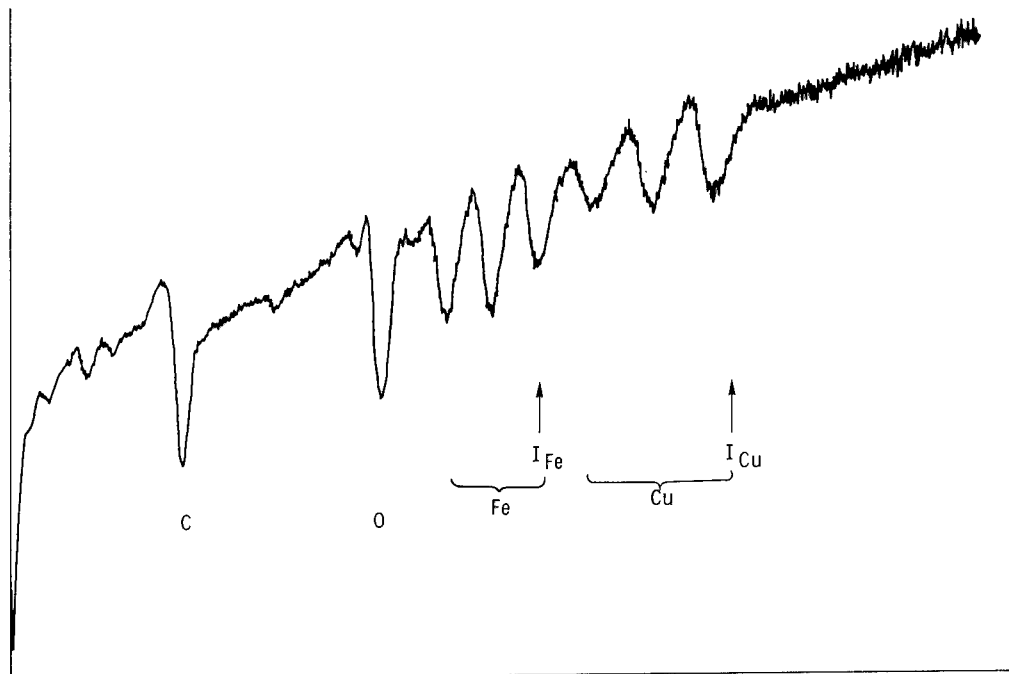

Figure 1. - Friction apparatus with Auger spectrometer.



(a) Before friction experiment.



(b) After 250 passes of a copper - 1-atomic-percent-nickel binary alloy over that surface.

Figure 2 - Auger emission spectroscopy spectrum of an AISI 52100 bearing-steel surface. Sliding velocity, 60 millimeters per minute; load, 100 grams; specimen temperature, 25^o C.

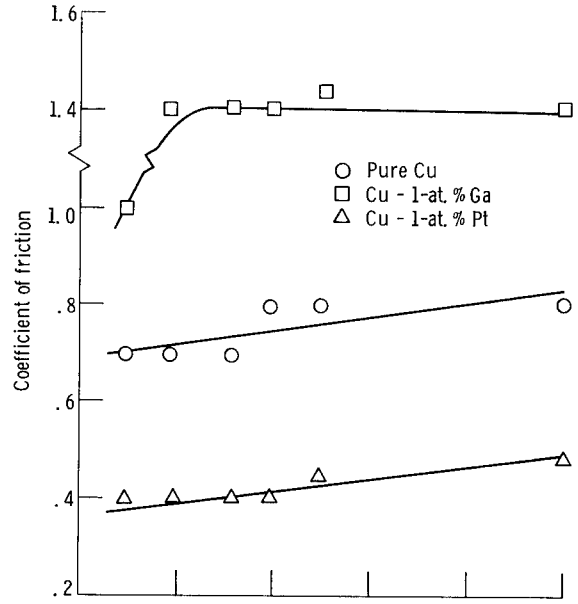

(a) Coefficient of friction.

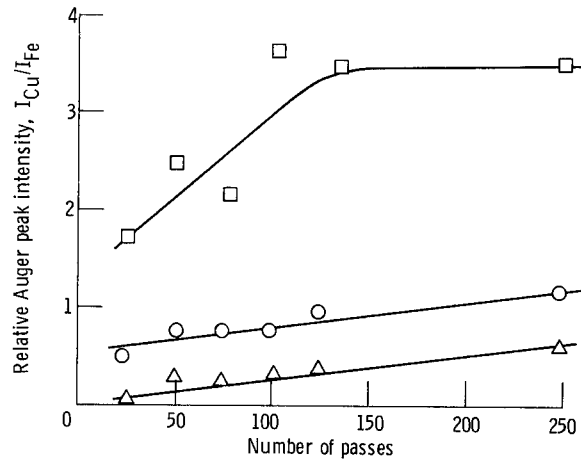

(b) Relative Auger peak intensity.

Figure 3. - Coefficients of friction and relative Auger peak intensities as function of number of repeated passes for binary copper alloys containing 1-atomic-percent germanium and platinum sliding on AISI 52100 bearing steel. Sliding velocity, 60 millimeters per minute; load, 100 grams; specimen temperature, 25° C.

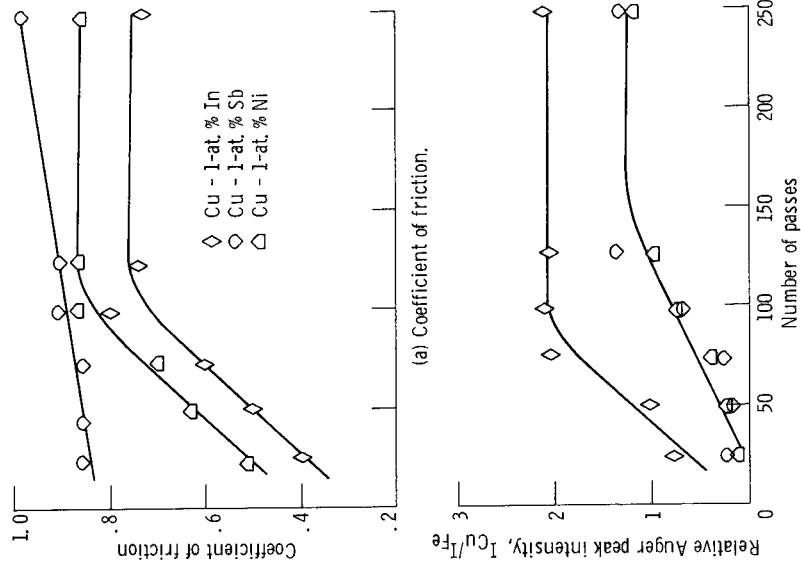

(a) Coefficient of friction.

(b) Relative Auger peak intensity.

Figure 5. - Coefficients of friction and relative Auger peak intensities as function of number of repeated passes for binary copposites as function of number of repeated passes for binary copposites containing 1-atomic-percent indium, antimony, and nickel sliding on AISI 52100 bearing steel. Sliding velocity, 60 millimeters per minute; load, 100 grams; specimen temperature, 25° C.

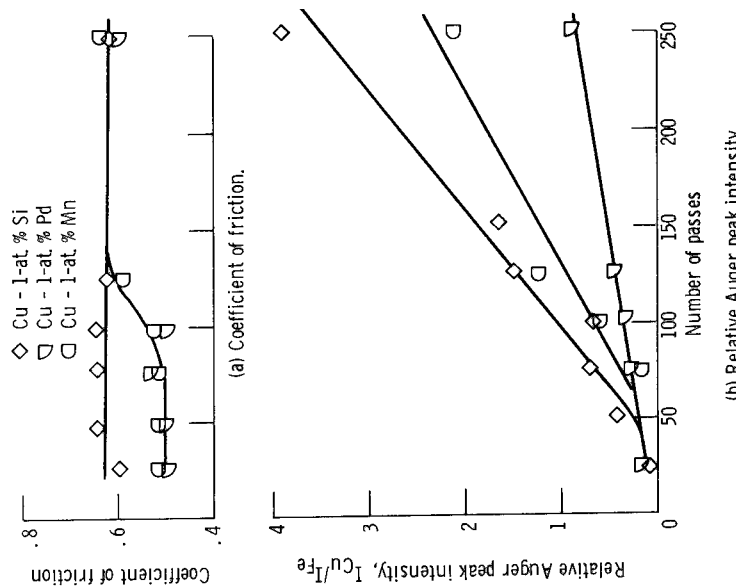

(a) Coefficient of friction.

(b) Relative Auger peak intensity.

Figure 4. - Coefficients of friction and relative Auger peak intensities as function of number of repeated passes for binary copper alloys containing 1-atomic-percent silicon, palladium, and manganese sliding on AISI 52100 bearing steel. Sliding velocity, 60 millimeters per minute; load, 100 grams; specimen temperature, 25° C.

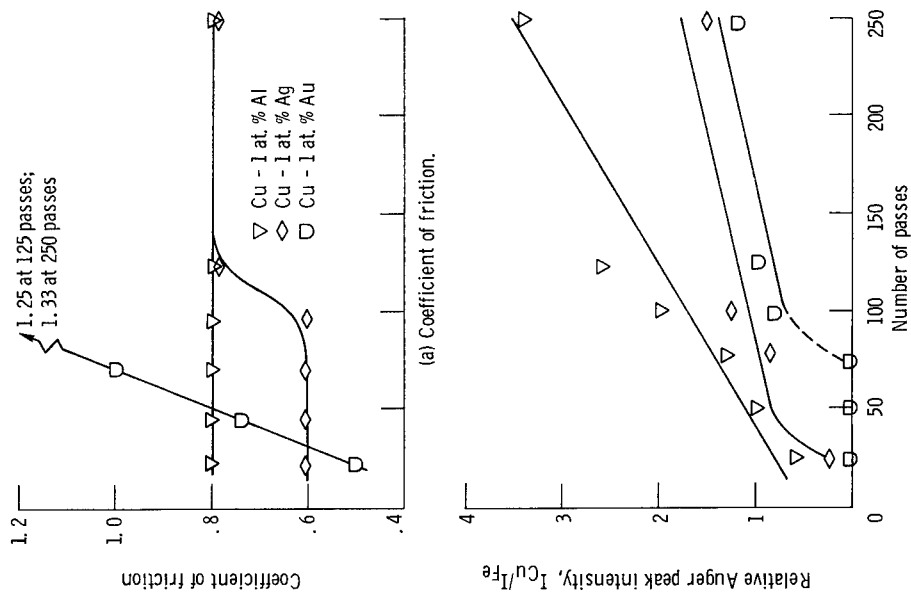

Figure 6. - Coefficients of friction and relative Auger peak intensities as function of number of repeated passes for binary copolymers containing 1-atomic-percent aluminum, silver, and gold sliding on AISI 52100 bearing steel. Sliding velocity, 60 millimeters per minute; load, 100 grams; specimen temperature, 25°C.

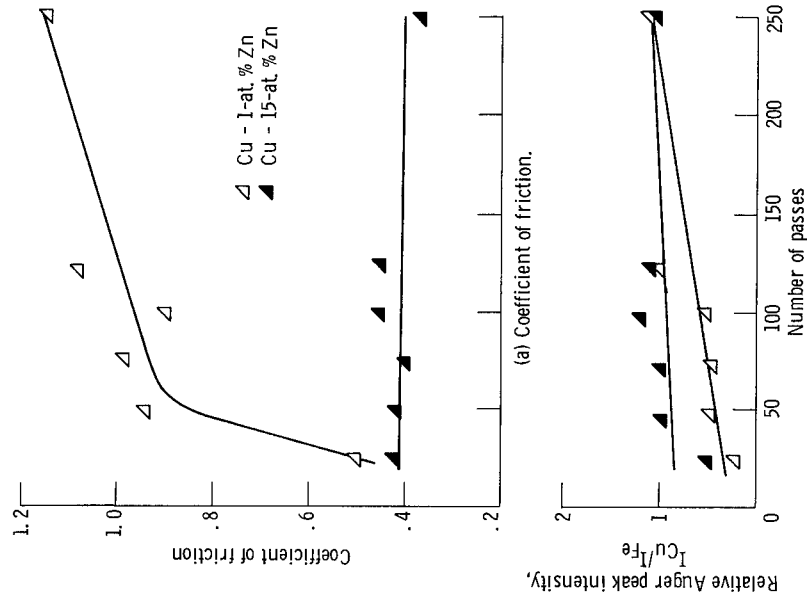

Figure 7. - Coefficients of friction and relative Auger peak intensities as function of number of repeated passes for binary copolymers containing 1-atomic-percent and 15-atomic-percent zinc sliding on AISI 52100 bearing steel. Sliding velocity, 60 millimeters per minute; load, 100 grams; specimen temperature, 25°C.

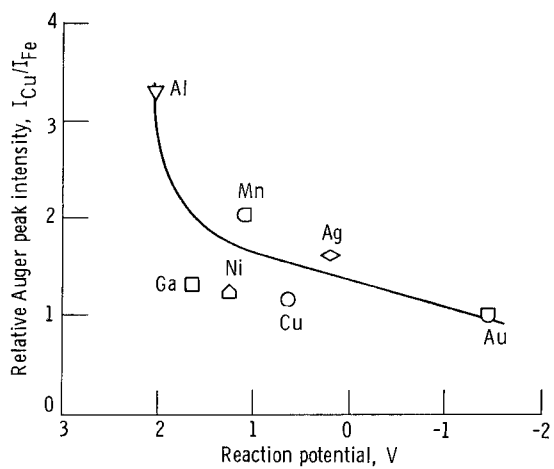

Figure 8. - Relative Auger peak intensities for binary copper alloys as function of reaction potential for elements alloyed with copper in a concentration of 1 atomic percent.

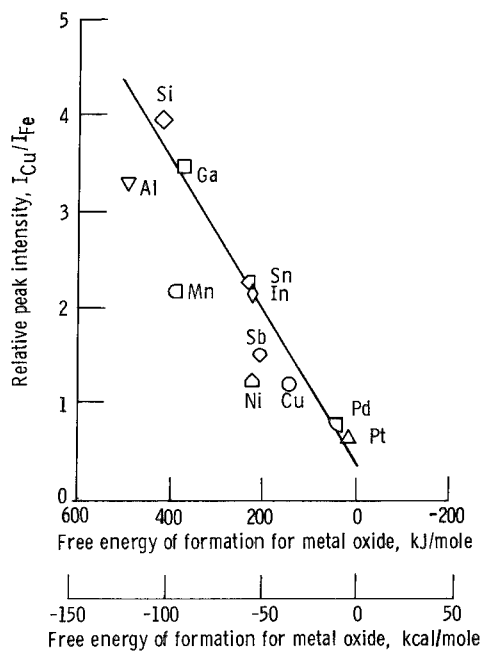

Figure 9. - Relative Auger peak intensities for binary copper alloys as function of free energy of formation of the oxides of the elements alloyed with copper in a concentration of 1 atomic percent.

1. Report No. NASA TP-1256	2. Government Accession No.	3. Recipient's Catalog No.	
4. Title and Subtitle ROLE OF ALLOYING ELEMENTS IN ADHESIVE TRANSFER AND FRICTION OF COPPER-BASE ALLOYS		5. Report Date June 1978	
		6. Performing Organization Code	
7. Author(s) Donald H. Buckley		8. Performing Organization Report No. E-9471	
		10. Work Unit No. 506-16	
9. Performing Organization Name and Address National Aeronautics and Space Administration Lewis Research Center Cleveland, Ohio 44135		11. Contract or Grant No.	
		13. Type of Report and Period Covered Technical Paper	
12. Sponsoring Agency Name and Address National Aeronautics and Space Administration Washington, D.C. 20546		14. Sponsoring Agency Code	
		15. Supplementary Notes	
16. Abstract Sliding friction experiments were conducted in a vacuum with binary-copper alloy riders sliding against a conventional bearing-steel surface with normal residual oxides present. The binary alloys contained 1 atomic percent of various alloying elements. Auger spectroscopy analysis was used to monitor the adhesive transfer of the copper alloys to the bearing-steel surface. There appears to be a relation between adhesive transfer and the reaction potential and free energy of formation of the alloying element in the copper. The more chemically active the element and the more stable its oxide, the greater is the adhesive transfer and wear of the copper alloy. Transfer occurred in all the alloys except copper-gold after relatively few (25) passes across the steel surface.			
17. Key Words (Suggested by Author(s)) Adhesion Friction Copper alloys		18. Distribution Statement Unclassified - unlimited STAR Category 26	
19. Security Classif. (of this report) Unclassified	20. Security Classif. (of this page) Unclassified	21. No. of Pages 17	22. Price* A02

* For sale by the National Technical Information Service, Springfield, Virginia 22161