

ENERGY ENGINEERING ANALYSIS PROGRAM

AT

THE TSA COMMISSARY

BUILDING 91 - QUARTER MASTER KASERNE
AUGSBURG MILITARY COMMUNITY
AUGSBURG, WEST GERMANY

US ARMY ENGINEER DIVISION, EUROPE
EUDED-SE
APO NEW YORK 09757

SUBMITTED BY

ENERGY ENGINEERING, INC.
SUITE 603
400 GORDON DRIVE
LIONVILLE, PA 19353

FINAL SUBMITTAL
28 JULY 1988
CONTRACT NO. DACA90-86-C-0106

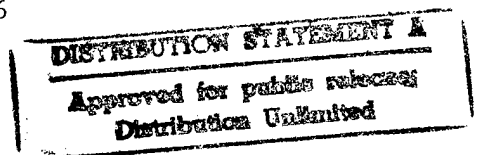

19971016 239

DTIC QUALITY INSPECTED 2



DEPARTMENT OF THE ARMY
CONSTRUCTION ENGINEERING RESEARCH LABORATORIES, CORPS OF ENGINEERS
P.O. BOX 9005
CHAMPAIGN, ILLINOIS 61826-9005

REPLY TO
ATTENTION OF: TR-I Library

17 Sep 1997

Based on SOW, these Energy Studies are unclassified/unlimited.
Distribution A. Approved for public release.

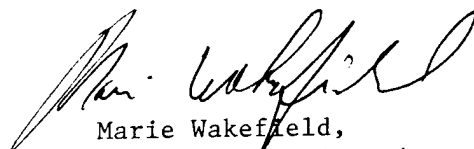

Marie Wakefield,
Librarian Engineering

TABLE OF CONTENTS

I.	Purpose of Report.....	i
II.	Executive Summary	
	A. Discussion.....	1
	B. Building Data and Fuel Costs.....	4
	C. Present Energy Consumption.....	5
	D. Historical Energy Consumption.....	10
	E. Analysis of Energy Conservation Opportunities.....	14
	F. Energy and Cost Savings.....	17
	G. General Recommendations for Commissary Facilities.....	21
III.	Methods of Analysis	
	A. Field Analysis.....	23
	B. Data Analysis.....	25
	C. Identification and Evaluation of Energy Conservation Opportunities.....	31
	D. Implementation Costs.....	35
	E. Follow-up Field Analysis.....	38
	F. Economic Analysis Procedures.....	39
IV.	Building Features	
	A. Building Condition and Changes in Usage.....	40
	B. Building Occupancy and Usage Patterns.....	40
	C. Gross Square Footage and Function Usage of Conditioned Spaces.....	40
	D. Envelope Characteristics.....	40
	E. Building Layout.....	43
	F. Building Photograph.....	43
V.	Operations of Building Equipment	
	A. Central Plant, Distribution, and Controls.....	45
	B. Heating System and Controls.....	45
	C. Ventilation System and Controls.....	47
	D. Domestic Hot Water.....	48
	E. Lighting Systems.....	48
	F. Refrigeration Equipment and Controls.....	48
VI.	Energy Conservation Projects	
	A. Energy Conservation Projects Recommended.....	50
	PROJECT #1 - HVAC, Lighting and Refrigeration.....	51
	B. Energy Conservation Opportunities Not Recommended.....	181
	ECONR #1 - Install Glass Doors on Open Dairy Cases.....	184
	ECONR #2 - Install Energy-Efficient Electronic Ballasts.....	189
	ECONR #3 - Exterior Lighting Conversion.....	194
	ECONR #4 - Exterior Lighting Conversions Parking Lot.....	203
	ECONR #5 - Insulate Roof/Walls.....	211
	C. General Recommendations for Commissary Facilities.....	216

TABLE OF CONTENTS (Continued)

VII. Operating and Maintenance Recommendations
A. Buildings Studied by EEI..... 222
B. General Recommendations for Commissary Facilities..... 224

VIII. Energy Efficiency of Pending Construction Projects..... 226

IX. Discussion of Results..... 227

- Appendix A - Memorandum
Appendix B - Field Notes
Appendix C - Methodology
Appendix D - Cost Estimates

ACKNOWLEDGMENTS

The cooperation and availability of the following personnel was vital to the development of this report; their assistance is gratefully acknowledged.

Project Engineers : Mr. Dale Bickenbach (EUD)
: Mr. Roger Cundiff (EUD)
: Mr. Don Fournier (USAREUR)
: Mr. Gran Gutterson (EUD)
: Mr. Mike Nowicki (USAREUR)
: Mr. Tom Small (Huntsville)

Augsburg Military Community: Herr Ament (Utilities)
: Mr. Claar (TSA)
: Mr. Connors (AAFES)
: Herr Kopf (AAFES)
: Herr Maher (TSA)
: Herr Pflierl (AAFES)
: Herr Stroetz (Utilities)
: Herr Strutzmeyer (Quarter Master Maintenance)
: Mr. Robert Wilson (DEH)
: Mr. Robert Yust (Master Planning)

Abbreviations

The following abbreviations are used throughout this report.

A	Area
AHU	Air handling unit
cfh	Cubic feet per hour
cfm	Cubic feet per minute
COP	Coefficient of performance
CWE	Current working estimate
ECIP	Energy conservation investment program
ECO	Energy conservation opportunities
EEAP	Energy Engineering Analysis Program
EEL	Energy Engineering, Inc.
DHW	Domestic hot water
DM	German marks
DoD	Department of Defense
FY	Fiscal year
gsf	Gross square footage
Htf	Heat transmission factor (U x A)
H&V	Heating and ventilating
HVAC	Heating ventilating and air conditioning
HP	Horsepower
Inf	Infiltration
Kw	Kilowatt
kWh	Kilowatt hour
MBtu	Million British thermal units
OA	Outside air
O&M	Operating and maintenance
PM	Preventive maintenance
PX	Post exchange
SBC	Single building controller also referred to an energy management and control system
SF	Square feet
SIOH	Government supervision, inspection and overhead
SIR	Savings to investment ration
U	Heat transfer coefficient
Vent	Ventilation

II. EXECUTIVE SUMMARY

I. Purpose of Report

This document is the final submittal for the energy conservation study conducted for Building 91, the commissary. This study is being funded through the Energy Engineering Analysis Program (EEAP). The Energy Engineering Analysis Program is an Army-wide program that studies energy conservation. This study is being conducted at the Augsburg Military Community in West Germany.

The EEAP has been authorized by the United States Department of the Army, European Division, Corps of Engineers, headquartered in Frankfurt, West Germany, under Contract No. DACA90-86-C-0106.

The purpose of this report is twofold:

- 1) Provide specific energy conservation recommendations for Building 91 in Quarter Master Kaserne;
- 2) Provide general energy conservation recommendations for commissary facilities.

A. Discussion

The potential to cost-effectively reduce energy costs in the TSA Commissary, building 91, at the Quarter Master Kaserne was notably limited when compared to other commissary facilities studied by Energy Engineering, Inc. (EEI). In particular, the new refrigeration compressors and controls and the good operations and maintenance of building systems limited the potential savings. A reduction in total energy costs of 17% is projected to result from the simultaneous implementation of all projects recommended in this report, for a cost savings of \$20,570 per year.

One project was developed for OSD PIF funding in this report consisting of the following items:

- 1) Lighting and Facility Modifications,
- 2) Single Building Controller (SBC)
- 3) Refrigeration and Building Weatherization
- 4) Refrigeration Heat Recovery.

The implementation cost for this project is estimated to total \$70,546. The combined simple payback (i.e., total implementation costs divided by total cost savings) for all recommendations in this study is 3.43 years. Project one possesses a savings to investment ratio (SIR) of 3.41.

A list of the items making up project one, implementation costs, annual cost savings, and annual energy savings can be found in Table I on the following page.

Undoubtedly, the greatest cost savings will result from the installation of a single building controller (SBC). Annual projected savings of \$9,870, or 48% of the total projected savings, are estimated. Estimated implementation costs of \$28,535 are expected.

One of the most cost intensive components of project one involves the installation of a heat recovery unit to utilize the hot gases from the compressor to heat hot water circulating to the buildings heating systems and domestic water system. This project will cost an estimated \$26,879 and save \$3,398 per year.

Lighting modifications and facility modifications will result in annual cost savings of \$4,822. This component will cost an estimated \$6,117 to implement.

Refrigeration and Building Weatherization, involves the installation of refrigeration strips and covers on the open refrigeration display fixtures, and also the repair of the loading dock's air barrier strips. Annual cost savings are projected to total \$2,480.

The operating and maintenance (O&M) practices currently employed in building 91 are very good. Refrigeration systems, heating systems, lighting systems, and the building structure are all well maintained.

TABLE I

<u>Components of of Project One</u>	<u>Implementation Cost</u>	<u>Annual Cost Savings</u>	<u>Annual Energy Savings (MBtu)</u>
Lighting & Facility Modifications	\$ 6,117	\$ 4,822	226
Single Building Controller (SBC)	\$28,535	\$ 9,870	903
Refrigeration & Building Weatherization	\$ 9,015	\$ 2,480	113
Refrigeration Heat Recovery	<u>\$26,879</u>	<u>\$ 3,398</u>	<u>363</u>
Total for Project 1	\$70,546	\$20,570	1,605

SIR = 3.41

Simple Payback = 3.43 years

Calculation of combined payback:

$$= \frac{\$70,546}{\$20,570} = 3.43 \text{ years.}$$

In the future, it will additionally be important to maintain high quality O&M procedures regarding the proposed implementation of a single building controller (SBC). Although the SBC is an exceedingly valuable, versatile tool in the control and monitoring of energy consumption, the system will require increased maintenance of both the SBC and the equipment which the SBC monitors and controls. Accordingly, it should be anticipated that additional responsibilities will result from the installation of a building control system. Specifically, a responsible individual must be committed to the daily monitoring and analyzing of system alarms, building conditions, and energy consumption through the recommended central monitoring station. It is not the intention for the commissary personnel to monitor and program the SBC. It will be the responsibility of the plant maintenance engineer to oversee the proper operation of the building controller. However, the commissary management should be briefed on the operations of the building system. On an average, one-half hour per day is needed to review alarms and building conditions. As the system expands, more time will be required for the daily routine monitoring of the SBC. Additionally, routine electrical/mechanical maintenance will be required to satisfactorily maintain system components. Accordingly, it is emphasized that cost savings are estimated based on an operable and well maintained building control system -- invariably, a poorly operated and maintained system will produce limited cost savings.

B. Building Description and Fuel Costs

Building 91 is a 26,329 square foot single-story structure utilized as a commissary. The heating systems consist of four (4) air handling units, five (5) unit heaters, two (2) air curtain heaters, and numerous perimeter radiators. All the systems are hydronic. The primary electrical consumer is refrigeration equipment. The refrigeration equipment consists of five racks of compressors serving various refrigeration display and storage fixtures. The total connected load of all the compressors is 76 kilowatts.

Fuel Costs

The fuel costs used throughout the report are:

Electricity: \$0.08248/kWh; \$24.166/MBtu;

Thermal (district heat): \$9.360/MBtu.

Electrical costs were obtained by taking the average cost for Quarter Master Reese and Sheridan Kasernes during fiscal year 1986.

The thermal cost used was that projected for district heat by USAREUR and EUD.

C. Present Energy Consumption

EEI calculated present energy usage through the use of an EEI computer program used in more than 300 previous energy studies. Specific algorithms utilized are detailed in the Methods of Analysis section of this report. Calculated electrical consumption projections were first compared to the electrical metered data to ensure the reasonableness of EEI's assumptions. Thereafter, projected consumption for building 91 was compared to similar buildings to further validate the electrical energy consumption calculations. Similar measures were taken to ensure the accuracy of the calculated thermal consumption.

Having established a current energy balance model, EEI typically examines and incorporates pending construction projects which would effect building utility consumption projects in building 91, however, the determination of a new energy balance was not necessary.

One of the pending construction projects involves replacing the existing warehouse with a new warehouse. This project is viewed to have little or no impact on the existing building heating systems. If in fact this project is implemented, the SBC will be able to easily accommodate any additional control points which may be needed to control any new heating system.

The following pages define the current significant energy consumption components in building 91.

CALCULATION OF AN ENERGY BALANCE FOR THE PERIOD OCT 85 - SEPT 86

BUILDING 91 - QUARTER MASTER KASERNE

Regarding present electrical consumption in building 91, the following table summarizes annual kWh totals for each category listed:

Energy Consuming Equipment	Annual kWh	Real Costs (\$)	Btu/SF/yr
Interior Lighting (INT LTG)	257,863	\$21,269	33,427
Exterior Lighting (EXT LTG)	9,969	\$ 822	1,292
Refrigerator Equipment (REFR EQPT)	669,745	\$55,241	86,818
H&V Auxiliaries (H&V AUX)	254,056	\$20,955	32,933
Miscellaneous Equipment (MISC EQPT)	17,750	\$ 1,464	2,301
Total	1,209,384	\$99,751	156,771
Actual*	1,208,169	\$99,650	156,614
% deviation from actual	0.1%	0.1%	0.1%

* Electrical consumption was estimated from a two week metering period and then adjusted for seasonal variations in equipment usage and building occupancy to obtain an annual consumption rate. For more specific details on the treatment of meter data refer to Section III, Methods of Analysis.

Graphically, electrical consumption in kWh can be portrayed as follows:

BUILDING 91 - QUARTER MASTER KASERNE - PRESENT kWh

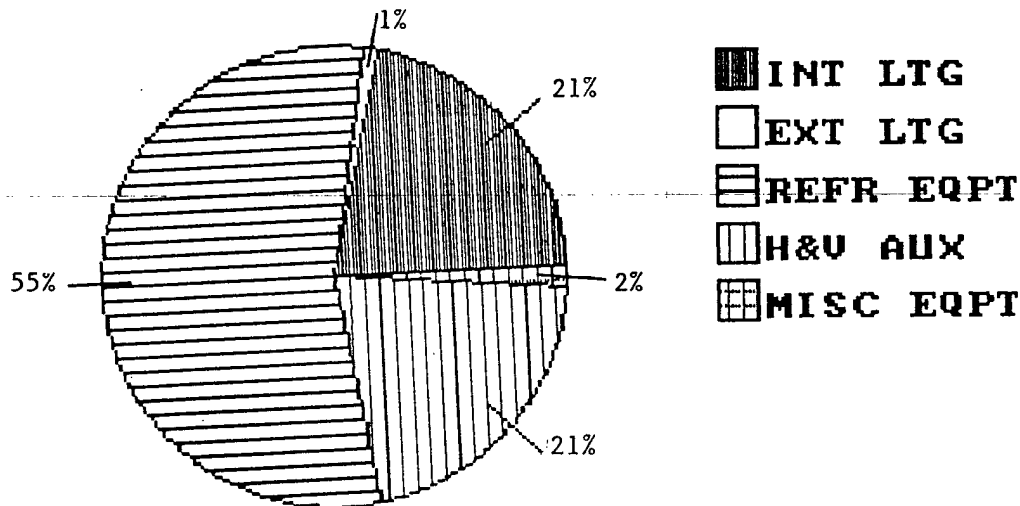

The largest electrical consumption component is refrigeration equipment. The five racks of compressors, totaling 76 kw, coupled with long equipment hours of operation, account for the majority of this high electrical rate. Interior lighting and H&V auxiliaries also represent a large portion of the electrical consumption. The consumption rate for H&V auxiliaries is extraordinarily high due in part to two 15 horsepower heating hot water pumps which serve the Centerville Housing Facility. Although these pumps do not serve the commissary, they are connected to Building 91 electrical meter and ultimately account for over 45% of the metered H&V consumption total. It should be emphasized that these pumps serve the housing facility and not the commissary. However, the pumps were metered in Building 91 and therefore the energy consumption is accounted in this energy balance.

Regarding thermal consumption, the following table illustrates the main sources of heating energy consumption for building 91.

Thermal Load Component	Annual MBtu's	Real Costs(\$)*	Btu/SF/yr*
Conduction - Walls (COND-WALLS)	300.43	\$ 2,274	9,227
- Windows (COND-WDWS)	131.98	\$ 999	4,054
- Roof (COND-ROOF)	927.14	\$ 7,018	28,476
- Slab (COND-SLAB)	91.73	\$ 694	2,817
Ventilation (VENTL)	218.06	\$ 1,650	6,697
Infiltration (INFIL)	109.68	\$ 830	3,369
Domestic Hot Water (DHW)	74.23	\$ 562	2,280
Heating to Offset Refrigeration (HTG/REF)	561.87	\$ 4,253	17,257
Less electrical heat gain to space	(462.10)	--	--
Total	1,953.01	\$18,280	74,177

* The cost and Btu/SF/yr rate for each load component has been corrected to account for the contribution from electrical heat gain to space.

The relative proportions of these thermal load components is detailed in the following pie chart.

BUILDING 91 - QUARTER MASTER KASERNE HEATING - MBtu's

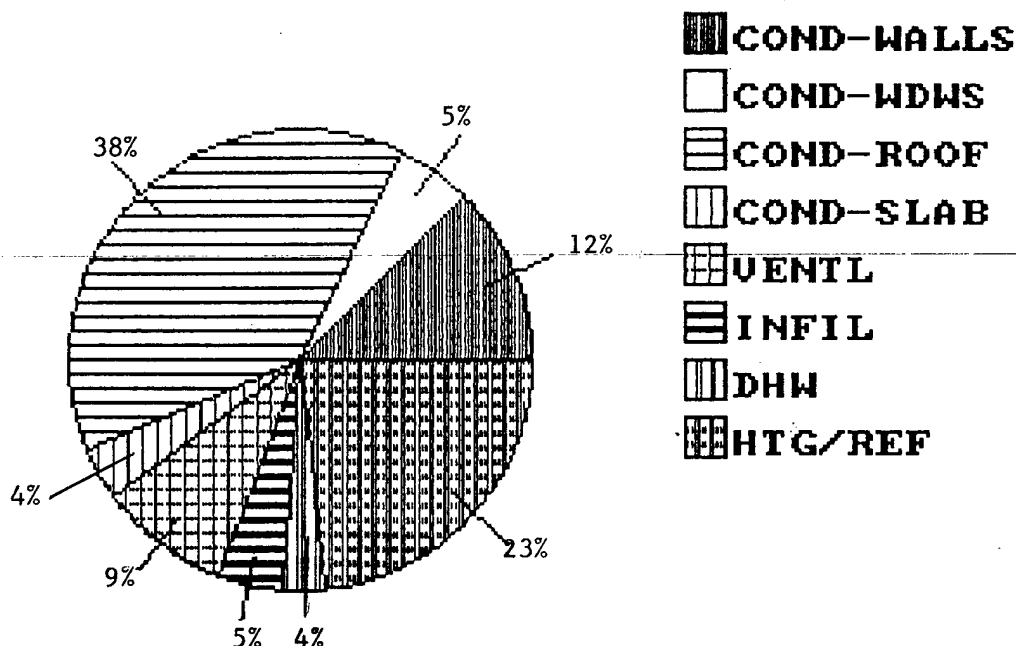

It is evident from the graphical display that the greatest conduction of thermal energy results from losses through the roof and walls -- the prefabricated metal construction of the warehouse contributes significantly to these high thermal losses. As typical of grocery stores with open display cases, the refrigeration load also adds significantly to the heating load -- the heating necessary to offset the spillover of cold refrigerated air in the open display cases constitutes 23% of the total thermal consumption. Other elements of thermal consumption are ventilation, infiltration, and generation and consumption of domestic hot water.

Finally, the following table and the two graphs on the next page depict the relative proportions of all energy users in building 91. The first graph details relative consumption amounts for each category listed, while the second graph details relative costs. Relative proportions of energy costs clearly indicate where the greatest potential for savings might be found. Most notable is the major cost expenditure for refrigeration equipment.

Energy Consumption Classification	Annual MBtu's	Real Costs(\$)	Btu/SF/yr
Interior Lighting (INT/EXT LT)	880.09	\$ 21,269	33,427
Exterior Lighting (INT/EXT LT)	34.03	\$ 822	1,292
Refrigerator Equipment (REFR EQPT)	2,285.84	\$ 55,241	86,818
H&V Auxiliaries (H&V AUX)	867.09	\$ 20,955	32,933
Miscellaneous Equipment (MISC EQPT)	60.58	\$ 1,464	2,301
Conduction - Walls (COND-WALLS)	242.95	\$ 2,274	9,227
- Windows (COND-WDWS)	106.73	\$ 999	4,054
- Roof (COND-ROOF)	749.74	\$ 7,018	28,476
- Slab (COND-SLAB)	74.18	\$ 694	2,817
Ventilation (VENTL)	176.33	\$ 1,650	6,697
Infiltration (INFIL)	88.69	\$ 830	3,369
Domestic Hot Water (DHW)	60.03	\$ 562	2,280
Heating to Offset Refrigeration (HTG/REF)	454.36	\$ 4,253	17,257
Total	6,032.52	\$115,538	229,121

Note: A new energy balance was not determined for this building because pending construction projects #C804065 - Construct an Equipment Storage Room to House Computer Equipment, #C207124 - Install a Heat Meter in Building 91 for Centerville Housing*, and #TAG5546 - Construct a Commissary Warehouse, are anticipated to have an insignificant impact on both the energy consumption of the building, and the applicability of the recommended energy conservation opportunities.

Dissecting the total energy used for comfort (i.e., heating, lighting, personnel, etc.) from the energy used for process (i.e., refrigeration, heating to offset refrigeration, miscellaneous etc.) depicts a typical load one would find in a department store or post exchange facility. The annual cost and energy used for comfort versus process is displayed in the table below.

	<u>Annual MBtu's</u>	<u>Real Costs (\$)</u>	<u>Btu/SF/yr</u>
Comfort	3,171.71	\$ 54,018	120,465
Process	<u>2,860.81</u>	<u>\$ 61,520</u>	<u>108,656</u>
Total	6,032.52	\$115,538	229,121

* Installing a heat meter in the Centerville Housing Facility will enable the facility to measure the energy being distributed there. This project, however, will not effect the energy consumption in the commissary.

BUILDING 91 - QUARTER MASTER KASERNE ENERGY MBtu's

ELECTRICITY AND THERMAL

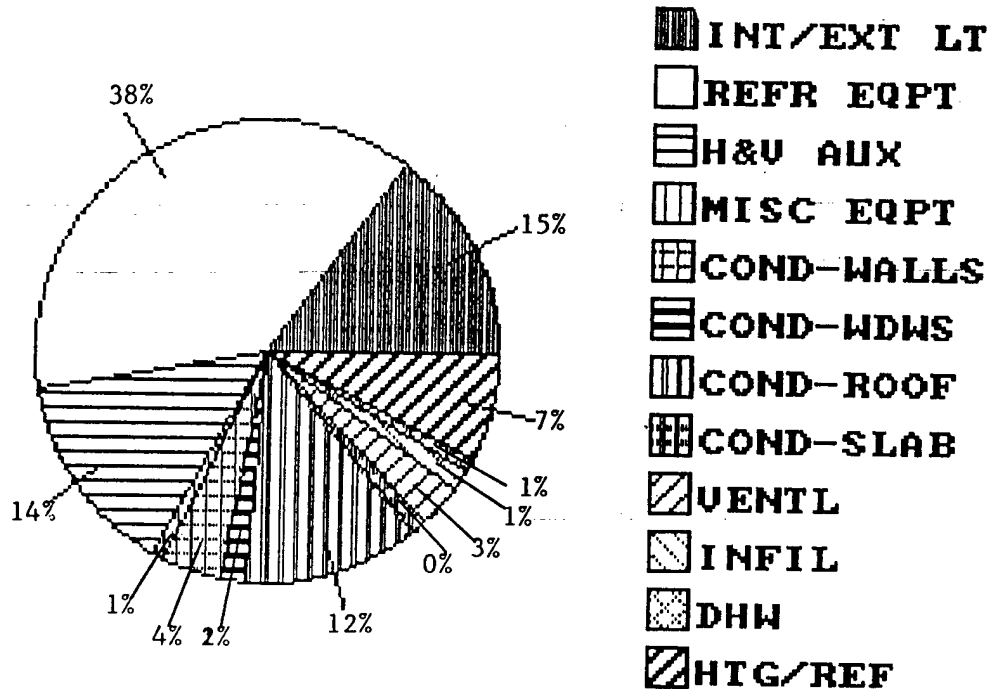

BUILDING 91 - QUARTER MASTER KASERNE ENERGY COSTS

ELECTRICITY AND THERMAL

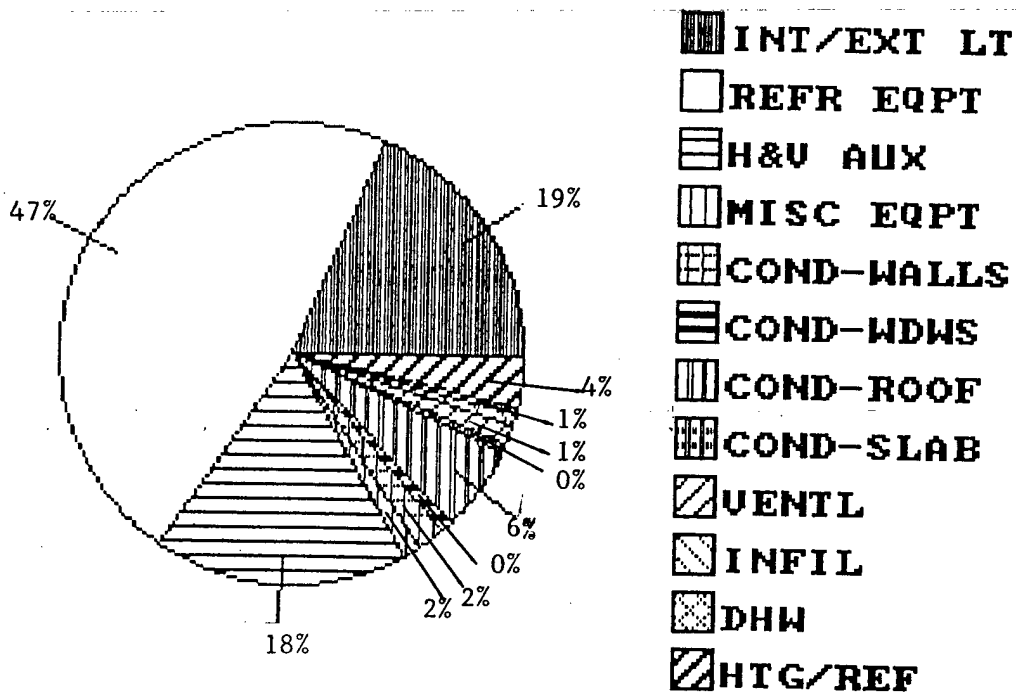

D. Historical Energy Consumption

Individual building meters do not exist in the building studied by EEI. Therefore, historical energy consumption could not be addressed for the individual building. However, base wide energy consumption was available and is addressed in this section. The consumption information listed in Tables II and III was provided by VII Corps Headquarters in Stuttgart and the DEH-Energy Conservation Office in Augsburg, West Germany.

Table II: Annual Energy Consumption (MBtu)

Fiscal Year	Electric	% Annual Change	Thermal	% Annual Change	Total	% Annual Change
1975	142,053	---	1,212,948	---	1,355,001	---
1976	143,786	1.2%	1,133,809	-7.0%	1,277,595	-6.1%
1977	152,435	5.7%	1,153,830	1.7%	1,306,265	2.2%
1978	149,039	-2.3%	1,141,001	-1.1%	1,290,040	-1.3%
1979	150,732	1.1%	1,229,549	7.2%	1,380,281	6.5%
1980	159,302	5.4%	1,148,036	-7.1%	1,307,338	-5.6%
1981	170,090	6.3%	1,099,015	-4.5%	1,269,105	-3.0%
1982	169,360	-0.4%	1,121,712	2.0%	1,291,072	1.7%
1983	172,732	2.0%	1,018,326	-10.2%	1,191,058	-8.4%
1984	179,196	3.6%	993,205	-2.5%	1,172,401	-1.6%
1985	189,186	5.3%	985,901	-0.7%	1,175,087	0.2%
1986	187,018	-1.2%	982,162	-0.4%	1,169,180	-0.5%
% Change from 1975 to 1986		31.7%		-19.0%		-13.7%

Table III: Annual Energy Use Index (Btu/sq ft)

Fiscal Year	Electric	% Annual Change	Thermal	% Annual Change	Total	% Annual Change
1975	15,238	---	130,117	---	145,355	---
1976	15,424	1.2%	121,627	-7.0%	137,052	-6.1%
1977	16,352	5.7%	123,775	1.7%	140,127	2.2%
1978	15,988	-2.3%	122,399	-1.1%	138,387	-1.3%
1979	16,169	1.1%	131,898	7.2%	148,067	6.5%
1980	17,089	5.4%	123,153	-7.1%	140,242	-5.6%
1981	18,246	6.3%	117,895	-4.5%	136,141	-3.0%
1982	18,168	-0.4%	120,330	2.0%	138,497	1.7%
1983	18,529	2.0%	109,239	-10.2%	127,768	-8.4%
1984	19,223	3.6%	106,544	-2.5%	125,767	-1.6%
1985	20,586	6.6%	107,280	0.7%	127,866	1.6%
1986	20,372	-1.0%	106,989	-0.3%	127,362	-0.4%
% Change from 1975 to 1986		33.7%		-17.8%		-12.4%

A wealth of information can be derived by examining annual consumption trends for the Augsburg Military Community. While Table II examines the annual energy consumption since FY 1975, a better measure for analyzing the energy use is provided in Table III. Table III depicts the energy use index since FY 1975 measured in Btu's per square foot. The square feet for the Augsburg Community remained constant from 1975 to 1981 at 9,322,000 square feet; in 1985 the community possessed 9,190,000 square feet and 9,180,000 square feet in 1986. However, there was no change in the commissary gross square footages.

FIGURE 1: Annual Electrical Use Index (Btu/SF)

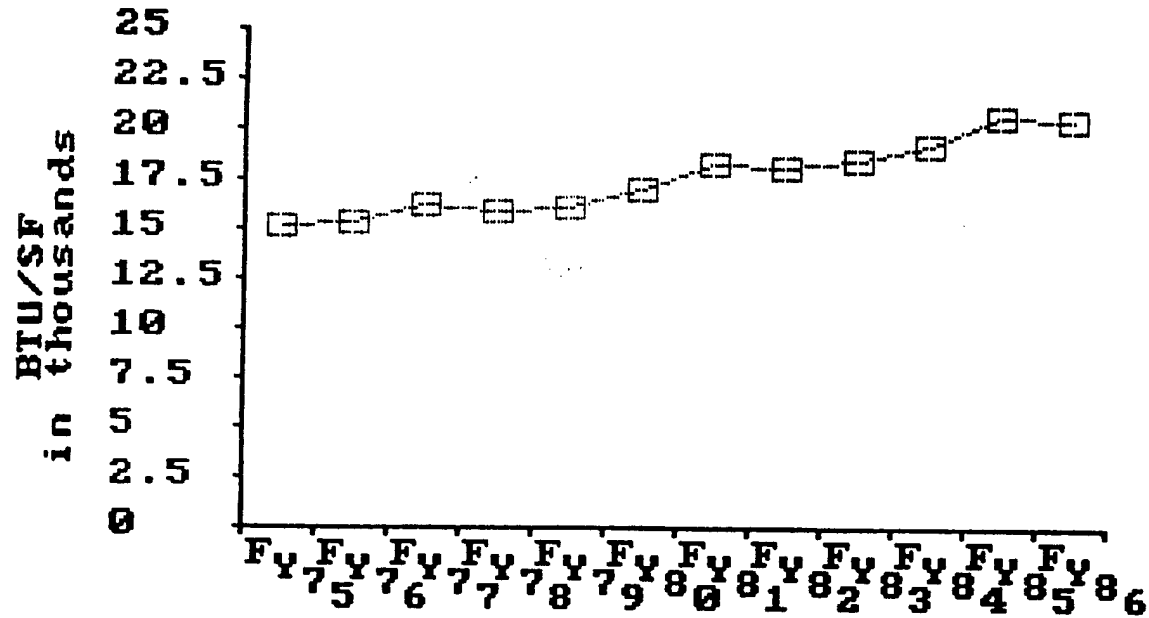

The annual electrical consumption has steadily increased from FY 1975 to FY 1986 except for slight decreases in FY 1978, FY 1982, and FY 1986. A total increase in the electrical consumption rate of 33.7% was experienced from FY 1975 to FY 1983. The most notable reasons for these increases can be attributed to the increased use of computers on base and the conditioning of computer spaces particularly in Reese and Sheridan Kasernes.

FIGURE 2: Annual Thermal Use Index (Btu/SF)

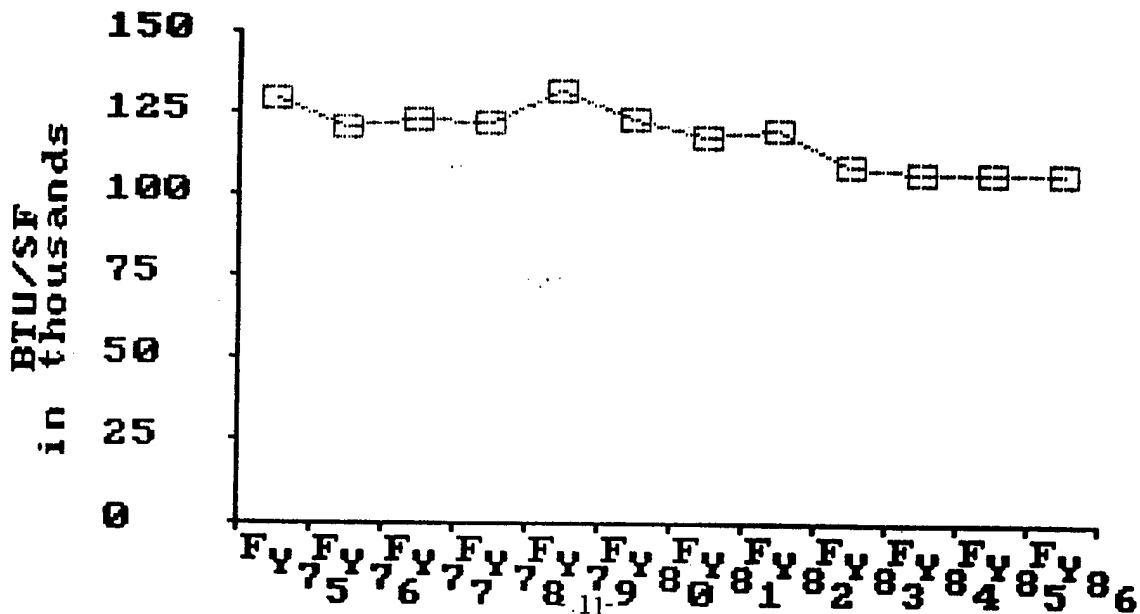

Regarding thermal consumption, annual trends depict a decline in energy consumption. The thermal consumption peaked in FY 1979 at approximately 132,000 Btu/SF to a low of 106,544 Btu/SF in FY 1984. Overall the thermal consumption rate has been reduced 17.8% from FY 1975 to FY 1986.

FIGURE 3: Total Energy Use Index (Btu/SF)

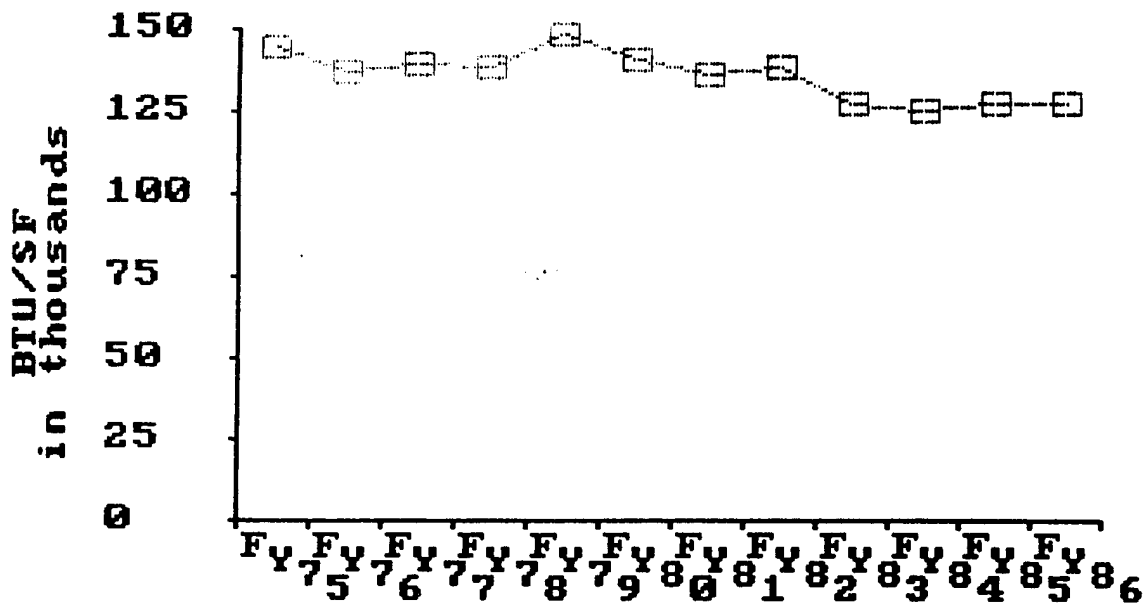

Finally, the analysis of total energy consumption reveals a 12.4% decrease from FY 1975 to FY 1986. This reduction in the total energy consumption rate can be attributed to the energy conservation implemented by the community. The following section details these efforts. Furthermore, the reduction in total energy consumption falls short of the mandate established by the Department of the Army to reduce overall energy consumption by 20% from the FY 1975 levels; the primary cause of this short fall is the substantial increase in electrical consumption.

Energy Conservation Efforts

Upon entering the Augsburg Military Base, it is hard not to notice the presence of an energy awareness program. Billboards and posters are displayed throughout the community to remind occupants of the benefits of saving energy. Moreover, incentive programs have been effectively created and utilized; for example, the renovations to the post office were paid for from the cost savings generated by the energy conservation efforts on base. Notably, the conservation efforts are clearly directed at the residents of the Augsburg community.

Energy conservation opportunities undertaken since 1975 include the following:

- installing outside air temperature reset controls;
- installing thermostatic control valves;
- reducing space temperatures through new controls and thermostat calibration;
- installing night setback controls;
- reducing domestic hot water temperature;
- insulating attics, roofs, and walls;

- installing thermopane windows and insulating doors;
- maintaining boilers;
- replacing steam heating systems with more efficient hydronic systems;
- repairing and installing new pipe insulation;
- consolidating boiler plants;
- installing timers for exhaust fans and lights;
- reducing lighting levels in corridors;
- installing photocells on security lighting;
- utilizing energy-efficient lamps.

E. Analysis of Energy Conservation Opportunities

A great many Energy Conservation Opportunities (ECOs) were investigated during the field survey for possible application in building 91. Table IV (see page 17) lists these ECOs. A majority of the ECOs: were previously implemented, were not applicable to the building, or were not economically justifiable (SIR <1) -- see Table V on page 16.

Ten (10) ECOs have been identified and recommended for implementation in building 91. These ECOs have been packaged into one project. Table I (on page 3) summarizes the recommended project, SIR, simple payback period, implementation cost, annual cost savings, and annual energy savings.

One component of project one, Lighting and Facility Modifications, is a combination of five (5) ECOs: 1) delamp excessively lit areas, 2) cycle anti-sweat heaters, 3) discontinue unnecessary lighting, 4) insulate pipes and valves, 5) interior lighting conversion. The minor modifications required to the lighting and facility systems will annually save \$4,822. An estimated implementation cost of \$6,117 is anticipated.

Clearly, the largest savings and the single most important item in this report involves the installation of a Single Building Controller (SBC). The recommended system should be capable of being connected to a base-wide central energy management control system. The enhanced control of building heating systems will result in cost savings of \$9,870 per year. This system will prove invaluable in assuring the optimal ongoing scheduling of energy consuming equipment. Estimated implementation costs will total \$28,535.

Total annual cost savings of \$2,480 are expected from Refrigeration and Building Weatherization. This item will reduce refrigeration expenditures by installing air barrier strips and night covers on the open display fixtures. Additionally, thermal energy will be saved by repairing the loading dock's air barrier strips.

Finally, the installation of a heat recovery unit which will utilize the hot compressor gases to heat the hot water being distributed to the building heating systems. This item is the second most cost intensive at \$26,879.

TABLE IV

ENERGY CONSERVATION OPPORTUNITIES INVESTIGATED

1. Insulate walls, ceiling and floors
2. Insulate pipes and valves
3. Install double glazing on windows
4. Install vestibules
5. Install loading dock seals
6. Install air barrier strips
7. Weatherstrip and caulk doors/windows
8. Add solar films to glass area
9. Reduce lighting levels (delamp)
10. Reduce unnecessary lighting
11. Interior lighting conversions
12. Exterior lighting modifications
 - a. exterior lighting conversions
 - b. install photocells
13. Utilize energy-efficient lamps
14. Utilize energy-efficient ballasts at burnout
15. Modify display lighting
16. Utilize reflectors for fluorescent lighting
17. Install energy-efficient motors
18. Variable speed drives for motors
19. Reduce anti-condensate heater operation
20. Return condensate
21. Infrared heaters
22. Prevent air stratification
23. Lower domestic hot water temperature
24. Shutdown water heaters during unoccupied periods
25. Waste heat recovery
26. Install night covers
27. Install air barrier strips for refrigeration fixtures
28. Cycle anti-sweat heaters
29. Scheduling of refrigeration equipment
30. Change refrigeration equipment to match smaller load
31. Improve refrigeration maintenance
32. Reduce refrigeration temperatures
33. Replace absorption chillers
34. Variable speed chiller compressor drives
35. Solar applications
36. Timers for bathroom exhaust fans
37. Connect air curtain to entrance doors
38. Single Building Controller (the following subheadings are all incorporated in the Single Building Controller evaluation)
 - a. install timeclocks
 - b. install night setback thermostats
 - c. reduce/increase space temperatures during winter/summer operation
 - d. reduce hours of operation
 - e. reduce outside air ventilation rates
 - f. dry bulb economizer cycles
 - g. revise/repair HVAC controls
 - h. demand limiting

TABLE V

ECO'S REJECTED

The following is a summary of ECOs that are not recommended because they fail to meet funding requirements as provided in DAEN-ZCF-U, "Energy Conservation Investment Program (ECIP) Guidance" (i.e., the projects possess an SIR <1).

<u>Title</u>	<u>SIR</u>
Install electronic ballast upon present ballast failure	0.68
Exterior lighting conversion - Building 91	0.65
Install glass doors on open dairy cases	0.58
Exterior lighting conversion - Parking Lot	0.48

F. Energy and Cost Savings

A 17% reduction in total energy costs amounting to \$20,570 can be realized in building 91 following the implementation of all the energy conservation opportunities (ECOs) recommended in this report. The resultant reduction in total energy consumption amounts of 1,605 MBtu or a 26% reduction in consumption. Table VI (on page 18) summarizes initial consumption, projects recommended and final consumption for building 91. This table is graphically represented in Figures 4 and 5 (on page 19) which portray electrical and thermal energy consumption before and after the implementation of the recommended project and in Figures 6 and 7 (on page 20) which depict the energy costs before and after project implementation.

Electrical costs and consumption will be reduced by 9%, amounting to savings of \$9,058 and 375 MBtu, respectively. The final building electrical energy use index (EUI) of 142,378 Btu/SF is reasonable in comparison to other commissary and supermarket facilities. The main contributor to this large electrical EUI is the continuous cycling of refrigeration compressors.

Regarding thermal consumption, a 63% decrease in costs is expected. Cost savings of \$11,512 are anticipated. The majority of the thermal savings is attributed to the SBC. The SBC will save 65% of the total projected thermal savings.

Table VI: Project Summary: TSA Commissary, Building 91-Quarter Master

		Annual Electricity	Annual Thermal	Annual Total Energy
		\$ MBtu Btu/SF	\$ MBtu Btu/SF	\$ MBtu Btu/SF
Initial Building Energy Cost & Consumption :		99650 4123 156614	18280 1953 74177	117930 6076 230791
Components of Project 1		Impl. Cost	SIR	
1. Lighting and facility modifications		6117 4418 183 6948	404 43 1639	4822 226 8587
2. Single Building Controller (SBC)		28535 2316 96 3639	7555 807 30655	9871 903 34294
3. Refrigeration and building weatherization		9015 2324 96 3652	156 17 633	2480 113 4285
4. Refrigeration heat recovery		26879	3398 363 13787	3398 363 13787
TOTALS :		3.41 70546 9058 375 14239	11513 1230 46714	20571 1605 60953
Final Building Energy Cost & Consumption :		90592 3748 142375	6767 723 27463	97359 4471 169838
Percent (%) Reduction :		9% 9% 9%	63% 63% 63%	17% 26% 26%

FIGURE 4: PRESENT ENERGY CONSUMPTION (MBtu)

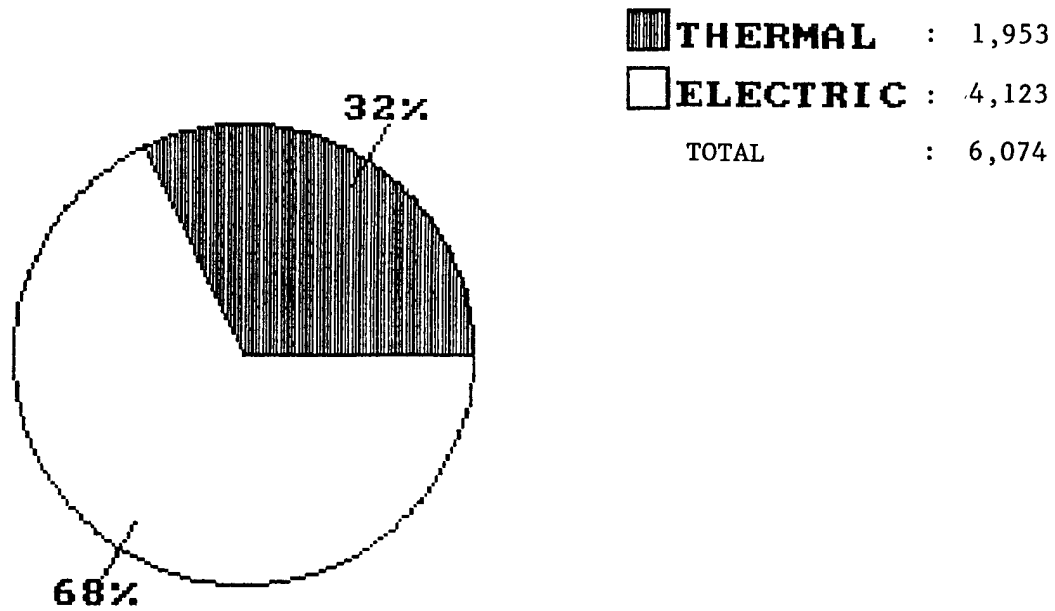

FIGURE 5: ENERGY CONSUMPTION AFTER IMPLEMENTATION OF PROJECTS (MBtu)

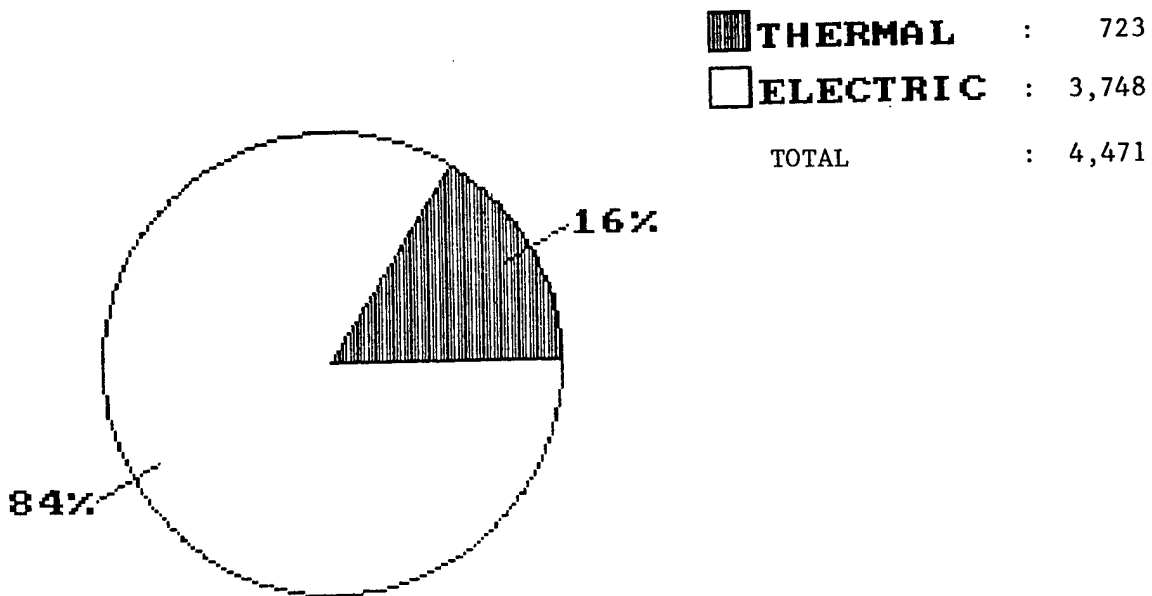
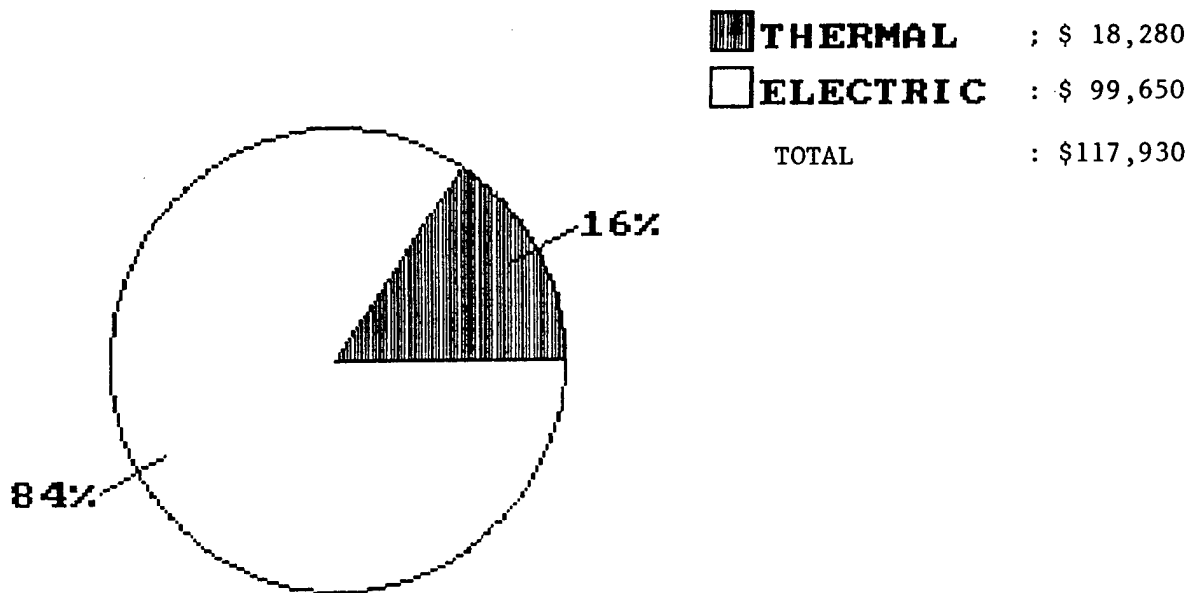

FIGURE 6: PRESENT ENERGY COSTS







 THERMAL	: \$ 18,280
 ELECTRIC	: \$ 99,650
TOTAL	: \$117,930

FIGURE 7: ENERGY COSTS AFTER IMPLEMENTATION OF PROJECTS

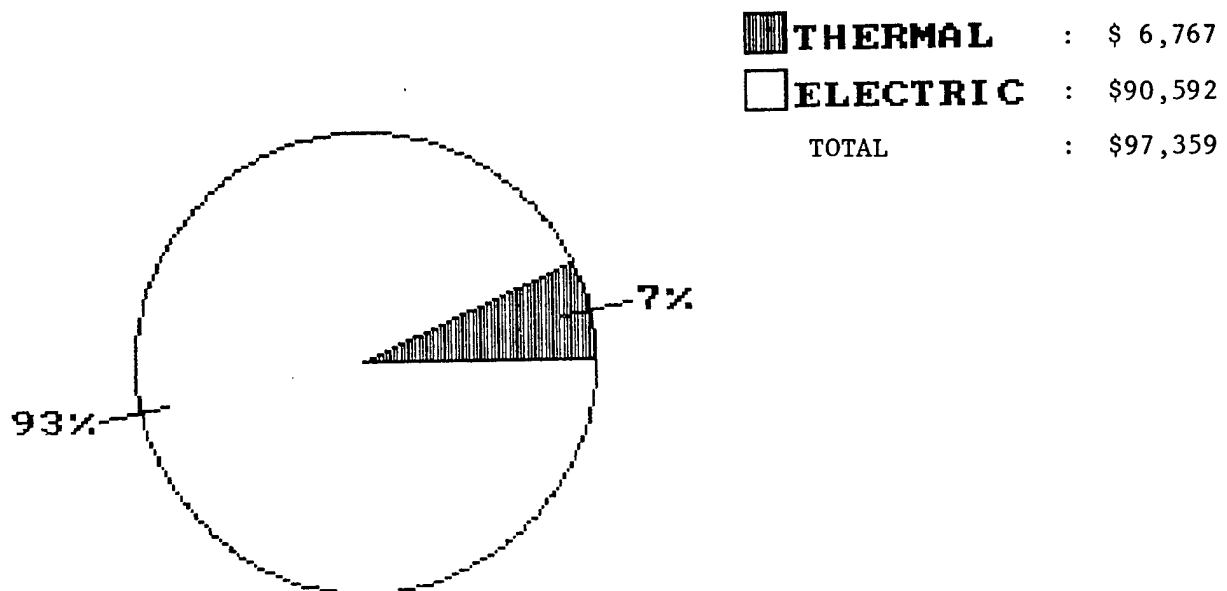

 THERMAL	: \$ 6,767
 ELECTRIC	: \$90,592
TOTAL	: \$97,359

G. General Recommendations for Commissary Facilities

The purpose of this section is to identify general energy conservation opportunities (ECOs) for commissary facilities as required by the scope of work. All of the recommendations which follow have been considered for implementation in building 91. The relevant projects have been evaluated and are summarized in Table VI on the preceding page.

- 1) Reducing Energy Costs in Wholesale Distribution, National Association of Wholesale Distributors, 1979;
- 2) Energy Conservation in Existing Buildings, DOE/CS-0132 U. S. Department of Energy, 1980;
- 3) Saving Money with Energy Conservation, DOE/CS-0141 U. S. Department of Energy, 1980;
- 4) Manual of Energy Savings in Existing Buildings and Plants, Stephen L. Baron, P.E., 1978.

There are several obvious characteristics which many commissaries have in common. The most notable is the continuous operation of the refrigeration systems. It is not uncommon for commercial refrigeration systems to account for as much as fifty percent (50%) of the total annual energy consumption in commissaries. Open display refrigeration fixtures are also common in most commissaries.

Two (2) other common characteristics include long lighting hours of operation and conditioning of storage spaces.

Sections VI.C and VII.B respectively review energy conservation opportunities and operating and maintenance (O&M) procedures for commissary facilities. Below are some of the highlights of these suggestions.

Reducing lighting energy is as easy as turning off the light switch. Unfortunately, the majority of the occupants leave lights on unnecessarily. The most notable areas include walk-in coolers/freezers, employee lounges, and remote storage areas. Automatic devices such as motion sensors and spring-wound timers will reduce lighting energy consumption. Removing selected lamps from overlit refrigeration display fixtures will also effectively reduce energy consumption -- additional benefits also result from an associated reduction in the refrigeration load. Other methods in which lighting energy can be reduced include utilizing task lighting, installing energy-efficient lamps, replacing incandescent lamps with fluorescent lamps, replacing exterior fixtures with more efficient high intensity discharge fixtures, and installing photocells on exterior fixtures.

The three (3) largest heating, ventilating and air conditioning energy saving opportunities result from:

- 1) reducing occupied/unoccupied space temperatures during the heating season and increasing temperatures during the cooling season;
- 2) reducing occupied equipment hours of operation;
- 3) reducing the outside air ventilation rates.

There are various methods to accomplish a reduction in HVAC energy costs. They include adjusting and calibrating controls, modifying energy inefficient sequences of operations, installing timeclocks, installing night setback thermostats, and implementing a quality preventive maintenance program. One of the most effective means available to control and monitor HVAC energy consumption is through a Single Building Control (SBC) unit. Generally, the annual cost savings provided through an effective SBC installation will offset the implementation costs in a period of two or three years. In a commissary application, additional benefits are realized by controlling and monitoring refrigeration systems. Substantial decreases in refrigeration costs can result by modifying compressor and defrost controls, optimizing condenser operations, monitoring and adjusting fixture temperatures, and limiting peak electrical demand. It is not uncommon to reduce energy costs by fifteen to twenty percent through the implementation of a Single Building Control system.

Refrigeration loads can be additionally reduced by installing air barrier strips and night covers to reduce the mixing of room air with refrigerated air. The open multideck display fixture is the most costly refrigeration unit to operate. Installing clear plastic air barrier strips allows customers to reach through the strips to obtain the product while also reducing energy losses. The single deck fixture or "coffin" unit is the most efficient display fixture. However, substantial losses are still realized. The installation of night covers will help reduce after-hours refrigeration costs. Other ways to reduce refrigeration costs include: cycling anti-sweat heaters; configuring system layout such that products requiring the same temperatures are served by the same compressor sets; turning off or increasing temperatures in areas not utilized after hours; adjusting and calibrating controls to provide maximum system efficiency; and, maintaining product temperatures as high as possible without jeopardizing product quality.

Recovering rejected heat from compressors and air cooled condensers will also reduce energy costs in commissary facilities. The recovered heat may be used to preheat water for the building heating systems, or directly in the building air handling units and fan coil units. In air conditioned buildings, recirculating the cold air found near the floor of open display cases will reduce air conditioning costs. Heat recovery systems on a retrofit basis can be quite expensive; however, if designers/engineers examine and incorporate waste heat recovery in the initial design stages, the incremental cost to purchase and install a heat recovery system can be economically rewarding.

B. General Recommendations for Commissary Facilities

The operation and maintenance of building systems is vital to energy conservation efforts. Poor O&M practices will unnecessarily waste energy and money. The following lists common O&M practices which can prove useful over the long term.

Lighting

- Institute a group relamping program; relamp when light output decreases to 75% of initial output.
- Clean all fixtures and diffusers when relamping.
- Utilize energy-efficient lamps when relamping.
- Turn off lights when not in use; instruct employees of the importance and benefits of reducing unnecessary lighting; it may also be advantageous to place posters and individual stickers on bulletin boards and next to light switches reminding the staff to turn lights off.
- Implement policy changes to reduce lighting levels during store closeout; utilize task lighting over cash registers and other areas where employees are still working.
- Establish incentive programs for both managers and employees to reduce lighting costs.
- Clean ceilings, walls and floors frequently to improve reflective qualities.
- Clean windows in areas where natural lighting is utilized.
- When repainting, select a light color to increase illuminance.
- Reduce lighting levels in display fixtures.
- Remove all incandescent lamps/spot lamps from meat displays.

Refrigeration

- Keep doors closed on all cases and walk-in coolers.
- Do not stack products above load lines; doing so reduces product quality and increases energy consumptions much as 10 to 20% for each fixture. Keeping the product two inches below the load line will decrease product temperature by 2 to 6°F.
- On multideck fixtures, follow manufacturer's suggestions in regard to shelf position and product sizes.
- Reduce/eliminate internal fixture display lighting; refrigeration load and lighting load will be reduced.
- Utilize night covers and plastic air barrier strips.
- Keep all fixtures clean.
- Clean condenser and cooler coils regularly.
- Clean drains.
- Remove all debris/obstructions from air grills.
- Check gaskets and latches on doors to be sure they close completely and form an airtight seal.
- Make sure the system has a full refrigerant charge.
- Have an annual system checkup performed by a refrigeration expert.

HVAC

Inspect and clean all systems on a regular basis. Remove all obstructions from heating/cooling systems. Keep all air registers clean and unobstructed. Some of the items to check include:

- radiators
- heating coils
- HVAC controls
- motors
- dampers
- air filters
- fan belts
- cooling coils
- condensing coils
- pipe insulation
- timeclocks
- thermostats

Building Structure

- Inspect exterior walls for cracks.
- Inspect windows and doors for excessive infiltration.
- Inspect windows and doors for proper closing operation.
- Keep windows and doors closed when building is conditioned.