

FINAL SUBMITTAL

ENERGY SURVEY OF  
EISENHOWER ARMY MEDICAL CENTER  
FORT GORDON  
AUGUSTA, GEORGIA

EXECUTIVE SUMMARY

CONTRACT NO. DACA01-94-D-0038

PREPARED FOR:

U.S. ARMY CORPS OF ENGINEERS  
SAVANNAH DISTRICT

**DISTRIBUTION STATEMENT A**

Approved for public release  
Distribution Unlimited

PREPARED BY:

REYNOLDS, SMITH AND HILLS, INC.  
AEROSPACE AND DEFENSE PROGRAM  
4651 SALISBURY ROAD  
JACKSONVILLE, FLORIDA 32256

PROJECT NO. 6941331005

DECEMBER 23, 1996

DTIC QUALITY INSPECTED 2

19971017 246



DEPARTMENT OF THE ARMY  
CONSTRUCTION ENGINEERING RESEARCH LABORATORIES, CORPS OF ENGINEERS  
P.O. BOX 9005  
CHAMPAIGN, ILLINOIS 61826-9005

REPLY TO  
ATTENTION OF: TR-I Library

17 Sep 1997

Based on SOW, these Energy Studies are unclassified/unlimited.  
Distribution A. Approved for public release.

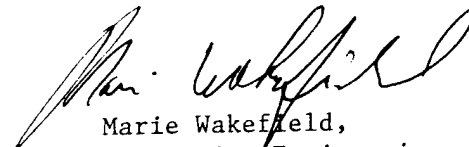
  
Marie Wakefield,  
Librarian Engineering

## TABLE OF CONTENTS

		<u>PAGE</u>
1.0	Introduction	ES.1-1
2.0	Existing Conditions	ES.2-1
3.0	Methodology	ES.3-1
4.0	Analysis	ES.4-1
5.0	Energy Plan	ES.5-1

## EXECUTIVE SUMMARY

### 1.0 INTRODUCTION

#### 1.1 AUTHORIZATION

The Energy Survey of the Eisenhower Army Medical Center (EAMC), Fort Gordon, Augusta, Georgia was authorized by the Department of the Army, Savannah District Corps of Engineers, under Contract Number DACA01-94-D-0038, Task Number 0005.

#### 1.2 OBJECTIVES

The objectives of this contract, as explained in the Detailed Scope of Work (Tab A in Volume II) of the contract, are as follows:

- Perform a complete energy audit of the entire Eisenhower Army Medical Center's (EAMC) heating and cooling systems, lighting system and other systems and areas.
- Perform a comprehensive analysis of all data collected during the audit.
- Identify all Energy Conservation Opportunities (ECOs) including low cost/no cost ECOs and perform complete evaluations of each. Energy equipment replacement projects already underway, approved, or planned by the Medical Center staff will be factored into the evaluations.
- Prepare programming documentation for all Federal Energy Management Program (FEMP) and/or Energy Conservation Improvement Program (ECIP) projects.
- Prepare implementation documentation and instructions for those projects recommended for accomplishment by local forces.
- List and prioritize all recommended ECOs.
- Prepare a comprehensive report which will document the work accomplished, the results of the field investigation and engineering analysis, the conclusions and recommendations.

#### 1.3 PHASES OF WORK

The work to be performed under the contract has been divided into three phases:

- Phase I—Field Investigation and Data Gathering.
- Phase II—Data Analysis. Analysis of data, identification of potential projects, performance of feasibility and economic studies and preparation of Life Cycle Cost Analysis forms. During this phase, all potential projects which produce energy and/or dollar savings will be identified and evaluated as to their technical and economical feasibility. Projects will be ranked according to their savings-to-investment ratio (SIR) value.

- Phase III--Report Preparation. Complete documentation of work accomplished. Project documentation for all justifiable ECOs.

There are three submittals planned for this project - Interim, Prefinal and Final.

#### **1.4 WORK ACCOMPLISHED**

An entrance meeting was held with the Director of the Department of Public Works (DPW), the Fort Gordon Energy Manager and other engineering personnel to discuss the scope of work, current energy initiatives at Fort Gordon and work plans and schedules for the field survey.

The initial field survey of the EAMC was performed on October 23 through 27, 1995. During that time, a team of engineers from Reynolds, Smith and Hills, Inc. (RS&H) performed tests, made observations and conducted interviews with installation personnel. The exit meeting was held at the end of the week with the Director of DPW, the Fort Gordon Energy Manager, and other engineering and maintenance personnel. Additional field surveys were conducted on November 15 through 17, 1995 and January 22 through 25, 1996.

Since that time, work has been performed in the analysis and documentation phases of the project. This included ECO evaluation, Life Cycle Cost Analysis, and documentation of the results and site survey observations. The results of these efforts formed the Interim Submittal.

Comments were received for the Interim Submittal and discussed during a review meeting at Fort Gordon on May 24, 1996. An additional site visit was made on June 18 through 20, 1996 to collect additional information for this study. Responses to the comments and additional analysis were incorporated into the Prefinal Submittal.

A site visit was made during the week of August 12, 1996 to gather additional data on the hospital steam pressure regulating valve and boiler condensate return system. Comments were received for the Prefinal Submittal and discussed during a review meeting at Fort Gordon on November 21, 1996. Responses to the comments and additional O&M recommendations were incorporated into the Final Report.

#### **1.5 WORK PLAN**

The plan for the remaining effort is shown in Figure 1.5-1. The plan includes schedules, durations of tasks and dates.

12-03-96

FORT GORDON  
Eisenhower AMC Energy Audit

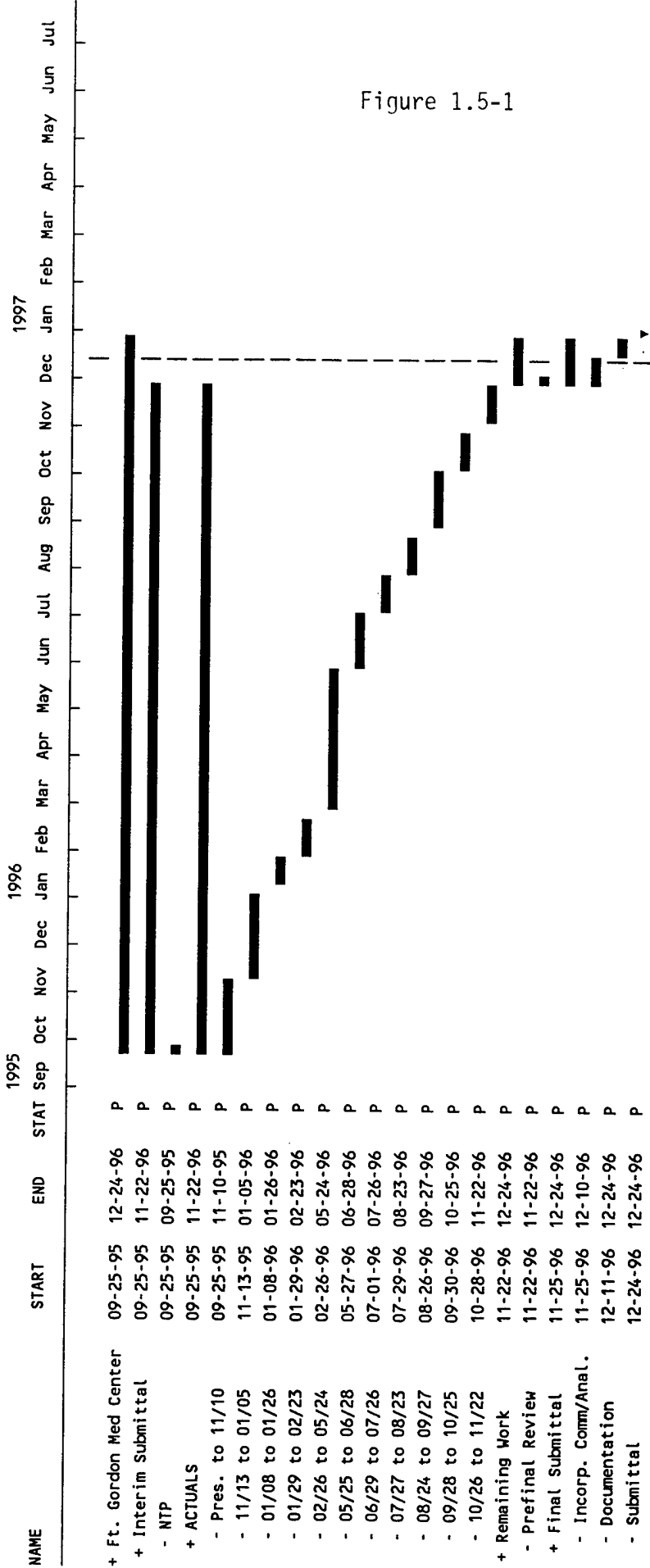

Figure 1.5-1

C: Completed    P: Planned    a: Actual Flag    v: Milestone    ■: Critical    ...: Normal    Scale: 1 Month = 5 character(s)  
 ▶▶▶: Resource Delay    ...: Slack    »»»»: Actual Progress

## 1.6 REPORT ORGANIZATION

The report consists of five volumes. Volume I, the Narrative Report, contains the results of all the field investigations, analysis and project development. The Detailed Scope of Work, Meeting Minutes and all backup data and calculations are found in Volume II, the Appendices. The field investigation notes are in Volume III and project documentation forms necessary for receiving funding are in Volume IV. Also included is an Executive Summary volume.

Volume I is the Narrative Report and its organization is explained here. Following a brief introduction in Section 1.0, the existing conditions at the Eisenhower Army Medical Center are discussed in Section 2.0. This includes a discussion of the FY96 Major Renovation Project, a description of the facility and current and past energy use patterns. Section 3.0 describes the techniques used to perform this study. Section 4.0 contains the results of the analysis of the energy conserving opportunities. The ECO Implementation Plan and the effects on energy use at Fort Gordon are located in Section 5.0.

## 2.0 EXISTING CONDITIONS

### 2.1 FY96 MAJOR RENOVATION PROJECT

A major renovation project for the EAMC was funded for FY96. This project includes major modifications to the heating and cooling plant as well as the HVAC system in the hospital. The following is a list of construction tasks from the Project Documents for the funded modifications to the Eisenhower Army Medical Center and its central heating and cooling plant. All ECOs will be evaluated on the basis that all of these renovations will be implemented.

Between the Interim and Prefinal Submittals, the renovation project was expanded to include replacement of all three boilers and associated controls. Therefore, some boiler improvement ECOs were evaluated but are not recommended.

#### Boiler Plant

- Replace:
- Four feed water pumps
  - Two condensate transfer pumps
  - Water softener system
  - Condensate return unit
  - Three boilers and associated controls
  - Steam and condensate piping and equipment insulation
  - Inlet vortex dampers on forced draft fans
- Remove:
- Economizers and induced draft fans

#### Chiller Replacement

- Replace:
- Two centrifugal chillers (Nos. 1 and 3) Refrigerant R-22
  - Three primary chilled water pumps P-1, P-2 and P-3
  - Three secondary chilled water pumps and add variable speed drives (VSDs) on pump motors
  - Three cooling towers and add VSDs to all cooling tower fan motors
  - Three condenser water pumps
  - Condenser water piping (the two centrifugal chiller towers will be manifolded)
  - All insulation

The chillers specified show a rated efficiency of 0.64 kW/ton and an APLV = 0.608 kW/ton. This is about the same efficiency as the existing units which have a rated efficiency of 0.65 kW/ton. Each of the new chillers have a nominal capacity of 1,080 tons, compared to 1,050 tons for the existing machines. This increases the plant cooling capacity by 60 tons.

#### Plant Management System

- Replace:
- All pneumatic operators
  - Outside air dampers (or repair)
  - Pneumatic controls system with direct digital type
  - Three-way chilled water valves with two-way types
  - Cooling coil and condensate drain pans
  - Cooling coil header piping insulation (inside fan room)
  - Reheat coils

Install: Chilled water line bypass to create primary/secondary supply loops. VSD on SF #5 and SF #6 supply and return fans to maintain positive pressure in controlled zone with respect to adjacent areas.

### New Energy (Plant) Management Control System

Features Include:

#### SF-1, SF-2 and SF-3

Scheduled start/stop, optimum start/stop and economizer Cold deck temperature reset

Hot deck temperature reset

Operation Schedule

SF-1 0600 - 1700

SF-2 0600 - 2100

SF-3 Continuous

#### OR AHU

Scheduled start/stop, optimal start/stop, day/night setback, economizer

Operation Schedule: 0700 - 1800

#### SF-4A and SF-4B

Scheduled start/stop, optimal start/stop, and economizer

Operation Schedule - Continuous

#### ICU AHU

Scheduled start/stop, optimal start/stop, day/night setback

Operation Schedule - Continuous

#### Kitchen Exhaust Fan

Scheduled start/stop

Operation Schedule - 0400 - 1900

Interlocked with make-up AHU

#### Hot Water Pumps

Scheduled start/stop, optimal start/stop

Day/night setback

Operation Schedule - Continuous

#### Chillers

Schedule start/stop, optimum start/stop

Chilled Water Reset, Condenser Water Reset

Chiller Demand Limit, Chiller Selection

Day/night setback (secondary CWP control)

Operation Schedule - Continuous

The absorption chiller and auxiliaries are used for demand limiting and during emergency power use.

Condenser water maintained at OSA wet bulb +5 degrees F, low limit 60 degrees F.

### SF-7 (2nd Floor Mechanical Room Ventilation)

Scheduled start/stop, optimum start/stop, demand limiting, day/night setback, economizer  
Operation Schedule - Continuous

### Exhaust Fans 1 Through 17

Scheduled start/stop  
Operation schedule:

EF-1:6 and EF-8:14 -	Continuous
EF-7 (Kitchen Hoods)	0400 - 1900
EF-15:17 (Sterilization, Kitchen, Allergy Clinic)	0500 - 1900

## **2.2 SYSTEMS DESCRIPTION**

### **Building**

The Eisenhower Army Medical Center (EAMC), Building 301, is located in the northeastern portion of Fort Gordon just off Chamberlain Avenue. It is easily accessed through McKenna Gate near U.S. Highway 78 and Gordon Highway (see Figure 2.2-1). The EAMC was brought into operation in 1976. The facility has 13 floors with 630,849 square feet of floor space. It is rectangular-shaped with the main entrance on one of the longer sides facing almost due north.

There are entrances to the hospital from all four sides. The main entrance and emergency room entrances are on the second level on the north side. The east side entrances are also on the second level and access the Magnetic Resonance Imaging (MRI) and Family Practice wings. The south entrance is on the fourth floor to the primary military administration areas. The loading docks are located on the west side and provide entrance to the third floor.

The exterior is approximately 15 percent windows. The windows are primarily single pane, but virtually all have blinds and/or drapes. The windows are recessed almost two feet to provide some shading.

The building peak population is estimated at 2,000 during the day. During the two other shifts, the number of people drops to about 400.

Facility operation hours are 7:30 am to 4:30 pm for the first four floors. The fifth through thirteenth floors are operational 24 hours per day. The exceptions are shown in the table below:

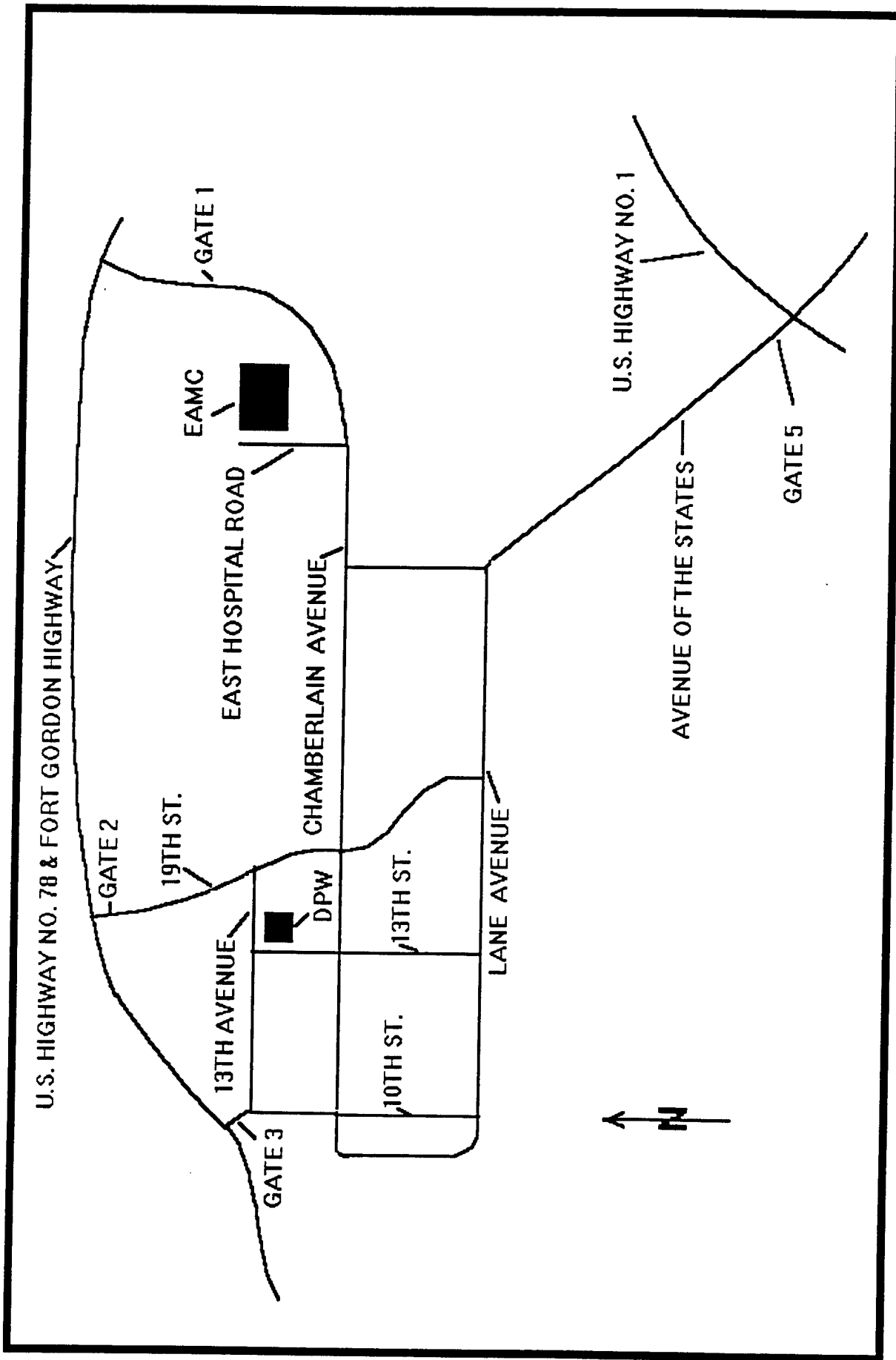

Figure 2.2-1 Building Area Diagram

**Floor**

1	Labs - 24 hours/day
2	Information Desk, Radiology, Emergency - 24 hours/day
3	Intensive Care, Pharmacy, CMS (Sterilization) - 24 hours/day, Surgical Suite is available for emergencies at any time

The Heating and Cooling Plant is located immediately west of the hospital. Maintenance for the hospital as well as the Heating and Cooling Plant is contracted to Johnson Controls Company.

**Lighting Systems**

The lighting system types were surveyed. The predominate lighting fixture is a two foot by four foot (two-by-four) recessed troffer with acrylic lens. The fixtures use two F40 CW (cool white) lamps with a single ballast and are used for supply and return of conditioned air. The original ballast is a standard magnetic type. Maintenance personnel estimate that about one half have been replaced with energy efficient magnetic types. Many office areas use two-by-four, four-lamp fixtures to provide higher lighting levels. Mercury vapor lamps are used in high ceiling areas such as lobbies and the cafeteria dining room. Lab areas on the first floor use four by four, eight lamp fluorescent fixtures to provide even higher lighting levels.

New T8 lamp fixtures with electronic ballasts are being installed in renovated areas. The tenth floor and the clinics in the northwest corner of the first floor have new parabolic fixtures using this high efficiency lighting system.

The Family Practice wing has a slightly different system. The primary fixtures are two-by-two U-bend and two-by-four parabolics using two, 34-watt fluorescents and energy efficient magnetic ballasts. The MRI wing has similar fixtures but uses F40 CW lamps with energy efficient magnetic ballasts.

Incandescents are used in smaller quantities throughout the hospital, primarily in restrooms and in some high ceiling areas.

Lighting levels were measured throughout the hospital. The results and a comparison with design requirements by area type are listed in Table 2.2-1. The only areas that are consistently over lighted are hallways, but not excessively. On several floors, every other hallway fixture was de-energized which brought light levels near the minimum.

Two other areas are over lighted. These are the library on the fourth floor and the general office area in the family practice wing. Both areas use four-lamp two-by-four fluorescent fixtures which produce 103 foot candles in the family practice area and 150+ foot candles in the library. The Family Practice area is dual switched, allowing half of the fluorescents to be de-energized at the wall switch.

**Table 2.2-1. Light Levels (Foot candles)**

<u>AREA TYPES</u>	<u>REQUIREMENTS<sup>(1)</sup></u>	<u>MEASURED</u>
Clinics, exam rooms	50	50-103 <sup>(2)</sup>
Administrative	50	50-95 <sup>(2)</sup>
Patient Bedrooms	30	10-50
Library	50	150+ <sup>(3)</sup>
Toilets	20	5
Hallways	10-15	10-35 <sup>(4)</sup>
Computer	50	70
Kitchen	70	50

**Notes:**

- (1) Source: MIL-HDBK-1191, Department of Defense, Dental and Medical Treatment Facilities Design and Construction Criteria, October 1991.
- (2) High values are in Family Practice wing, medical records area and exam rooms.
- (3) Fourth floor library.
- (4) On some floors half of the hallway lights have been de-energized. The light levels on these floors average ten foot candles.

**Heating And Cooling Systems**

**Chilled Water System.** Chilled water production is accomplished by three chillers located in the south end of the central energy plant, Building Number 310. This facility also houses the boilers and is located across the street just west of the hospital. The chillers are numbered CH-1, CH-2 and CH-3 from west to east. These chillers provide chilled water (CHW) to provide space cooling in the hospital and the medical barracks that are located south of the central energy plant. The chilled water supply is a single loop system with primary pumps located in the plant and booster pumps in series located in the hospital (see Figure 2.2-2).

**Chillers.** Chillers CH-1 and CH-3 are 1,050 ton, electrical-driven, centrifugal types manufactured by York. Originally designed in 1985, these chillers are rated at 0.65 kW/ton. These chillers are approximately ten years old and are in good condition. There have been several problems with chiller CH-1. The compressor

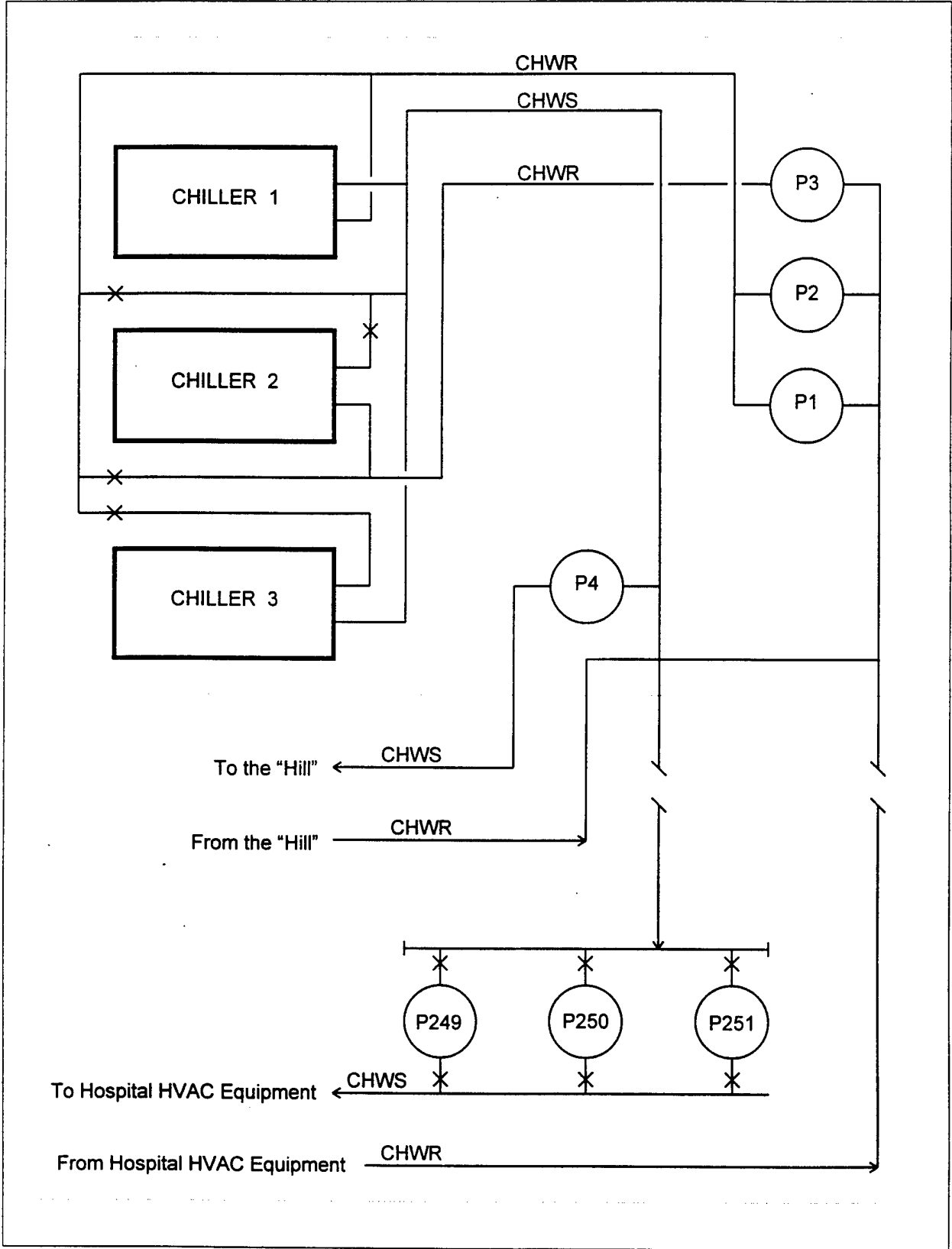

Figure 2.2-2

has failed at least two times and been repaired by the manufacturer. In 1995, the rear bearings for the compressor motor failed. The motor was removed and sent to the manufacturer for rebuilding. The chilled water supply set point for the centrifugal chillers is 41.5 degrees F. The operator indicated chillers CH-1 and CH-3 provide a total of approximately 1800 tons of cooling during periods of peak cooling demand. Both centrifugal chillers are scheduled to be replaced in the FY96 Renovation Project.

Chiller CH-2 is a 500 ton, natural gas-fired absorption unit manufactured by Trane. The design COP is 1.07. This chiller was installed in early 1995. The field investigation of the absorption chiller was accomplished during a cool afternoon on November 16, 1995, while the outside air temperature was 58 degrees F. Chiller CH-2 was operating at approximately 60 percent of full load fuel input and was the only chiller operating during the survey. The measured CHW supply and return temperatures were 52 degrees F and 60 degrees F, respectively. The calculated chilled water flow was 1,987 gallons per minute (gpm), compared to the design value of 1,152 gpm. The calculated condenser water flow was 2,212 gpm, compared to the design value of 2,187 gpm. The condenser water flow is normal, but the chilled water flow exceeds the recommended maximum of 1,466 gpm. This could cause premature fouling in the evaporator tubes.

The loading of the absorption chiller was dictated by the leaving condenser water temperature and not the actual cooling load required by the hospital. The fuel input was manually adjusted to keep the leaving condenser water temperature at approximately 100 degrees F. Chiller CH-2 has not been operated very often due to excessive condenser water temperatures.

**Cooling Towers.** There are four cooling towers located just west of the central energy plant, one for each of the three chillers and one serving the emergency generator. The towers are numbered #1, #2 and #3 from east to west and serve the chillers with the same corresponding numbers. The tower serving the emergency generator is CT-4. All towers are cross-flow types with induced draft fans and open-basin water distribution systems. All distribution basins contained pipe scale which were partially clogging the drain holes. All make-up water valves were either missing or malfunctioning. Large amounts of water flow continuously to the tower basins irrespective of need. During much of the survey, the ground around the towers was under several inches of water due to tower basin overflow. The fans cycle to maintain approximately 80 degrees F condenser water to the chillers.

#### **Hot Water System**

Hot water is produced via steam-to-hot water heat exchangers located in the EAMC second floor mechanical room. Hot water is pumped to reheat coils in the various areas throughout the hospital. Local room thermostats control hot water valves to maintain space temperatures. Figure 2.2-3 shows the hospital steam supply process.

# EISENHOWER ARMY MEDICAL CENTER

## Hospital Steam Supply Diagram

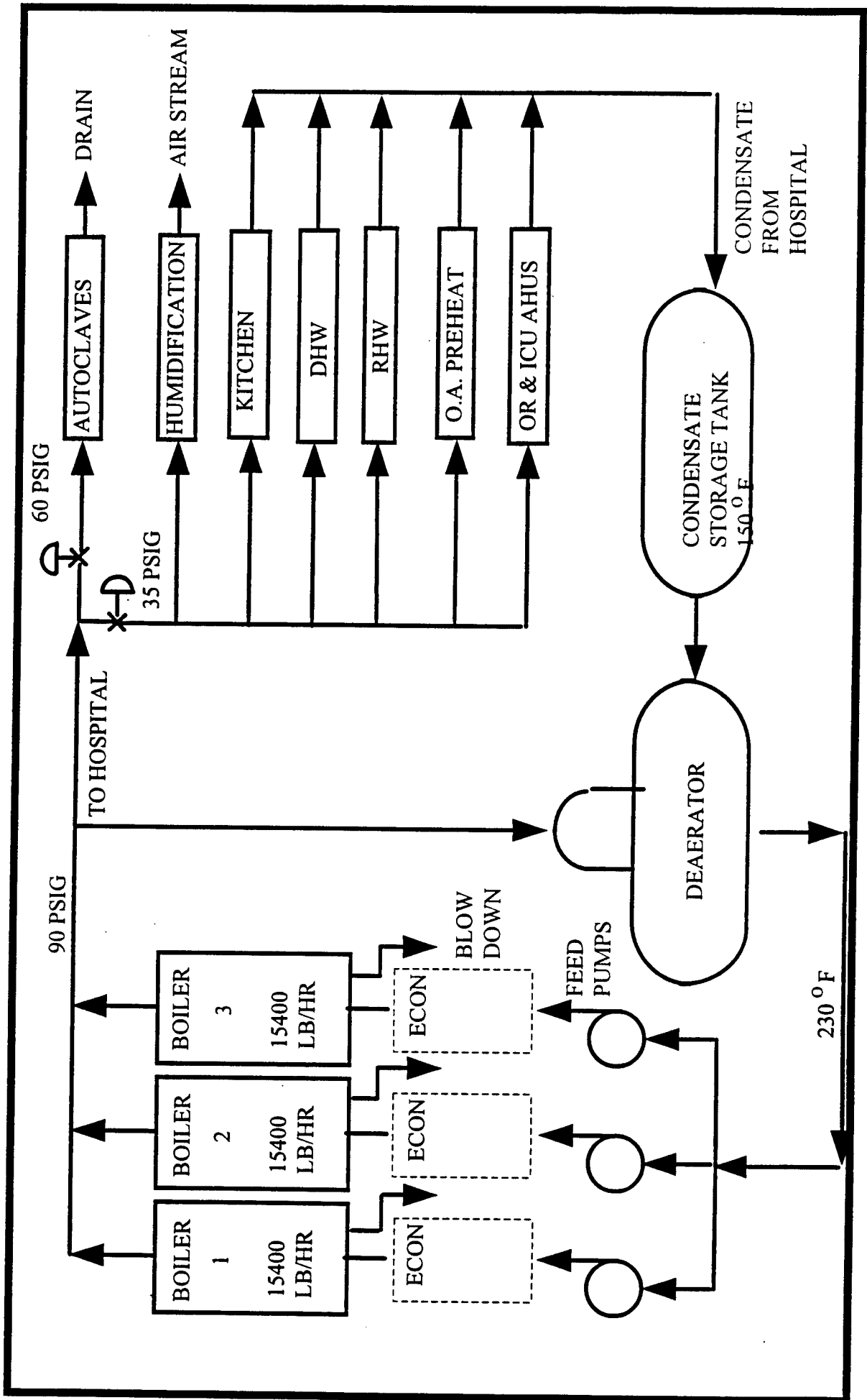

Figure 2.2-3

**Boilers.** Steam is generated by three D-Type boilers manufactured by International Boiler Company and installed in 1976. Each has a nominal steam generation capacity of 15,400 lbs/hr (~15 MBtu/hr). All three units are single burner, dual fuel (natural gas and No.2 fuel oil), designed for 150 psig, and intended for operation at 125 psig to support turbine-driven chillers. The turbine-driven chillers have since been removed.

The boilers now operate at 75-90 psig supplying steam to the hospital (see Hospital Loads below for steam uses); and to the adjacent barracks for space heating and domestic hot water. Condensate from both locations is returned. Natural gas is used almost exclusively. Typically, only one boiler is needed to meet loads. The peak winter demand has never required more than two boilers. This was confirmed when we reviewed the boiler operating logs. Figure 2.2-4, which was generated from boiler log data, shows that only in the coldest weather would more than one boiler be required.

The boilers appear to be in generally good condition. The boiler area was clean and neat. The operators reported that during a recent boiler shutdown, the boiler tubes were visually inspected internally and found to be in good condition. There has never been a tube leak in any of the boilers.

We did, however, note many problems with boiler operation. The boiler steam pressure is changing rapidly (spiking) resulting in sudden demand for, or reduction of, steam flow. The magnitude of the steam flow change can be as much as 40 percent of boiler capacity. The frequency of these episodes are as often as four to six times per hour and continue around the clock. (On a survey trip in June 1996, cycles with periods of 40 seconds were observed.) A review of past boiler recorder charts reveal that this phenomena has been occurring for many months. This continual spiking is causing drum level swings that can become nearly unmanageable. Often, the operator must put another boiler into service to dampen the swings to regain control of the drum level. The air flow and fuel flow are swinging with each spike.

Operators report carryover problems. The exact cause is not determinable due to the severe cycling of the boilers. There appears to be steam regulation problems with 35 psi pressure reducing valves in the hospital. They may not be properly controlling the pressure in the 35 psi header system. The safety valve in that system is set at 46 psig and often pops to relieve excess pressure. That problem, coupled with the poor state of the boiler controls, makes it very difficult to determine the extent to which either is contributing to the carryover.

All boilers and associated controls are to be replaced as part of the FY96 Renovation Project.

### **2.3 HISTORICAL ENERGY USE AND COSTS**

The EAMC is metered and billed separately from the rest of the installation. The results of this metering are displayed in graphs in this section.

# EISENHOWER AMC Boiler Plant Steam Flow

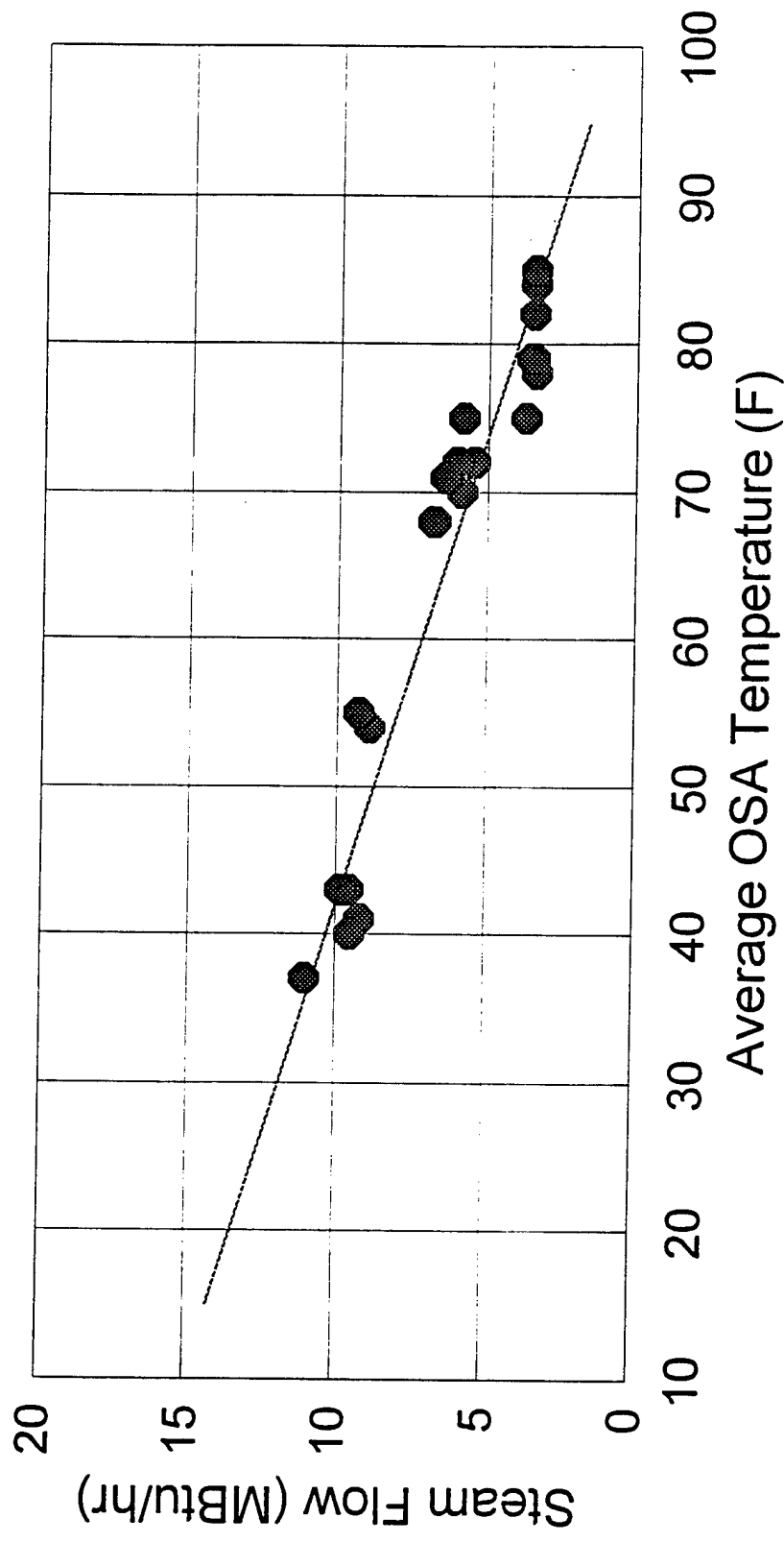

Figure 2.2-4

Historical electricity use and demand are shown in Figures 2.3-1 and 2.3-2. Both use and demand have varied little over the past three years. In FY95, the annual electricity consumption was 24,296,400 kilowatt hours, or 82,924 MBtu. The peak demand was in August 1995 at 4,101 kW. The highest demand in the past three years was 4,201 kW in September 1994.

Natural gas use (Figure 2.3-3) shows considerably more variation, especially during the winter months. There appears to be no particular trend in natural gas use over the past three years. The drop in natural gas use in December 1994 was when the boiler plant was operated almost entirely using fuel oil as a test. The natural gas use in FY95 was 696,960 therms or 69,696 Mbtu.

Figure 2.3-4 shows the energy use breakdown by fuel type for FY95. On a Btu basis, the energy consumption of electricity and natural gas are about equal. The total use for FY95 is 152,619 MBtu, yielding an energy use index (EUI) of 242 kBtu/sf/yr. Energy use has changed little over the past two fiscal years (Figure 2.3-5). The decrease between FY93 and FY94 was primarily due to natural gas use which is weather dependent.

The cost breakdown by fuel type is shown in Figure 2.3-6. Electricity dominates at 85 percent of the \$1,266,800 total. The average cost per kWh of electricity is 4.5 cents/kWh. Natural gas averaged 26.8 cents/therm in FY95. Figure 2.3-7 shows total utility costs have varied little over the past two years. Costs are down from FY93 due to decreased natural gas use and prices. The energy cost index (ECI) for FY95 was \$2.01/sf.

# EISENHOWER ARMY MEDICAL CENTER Historical Electricity Use

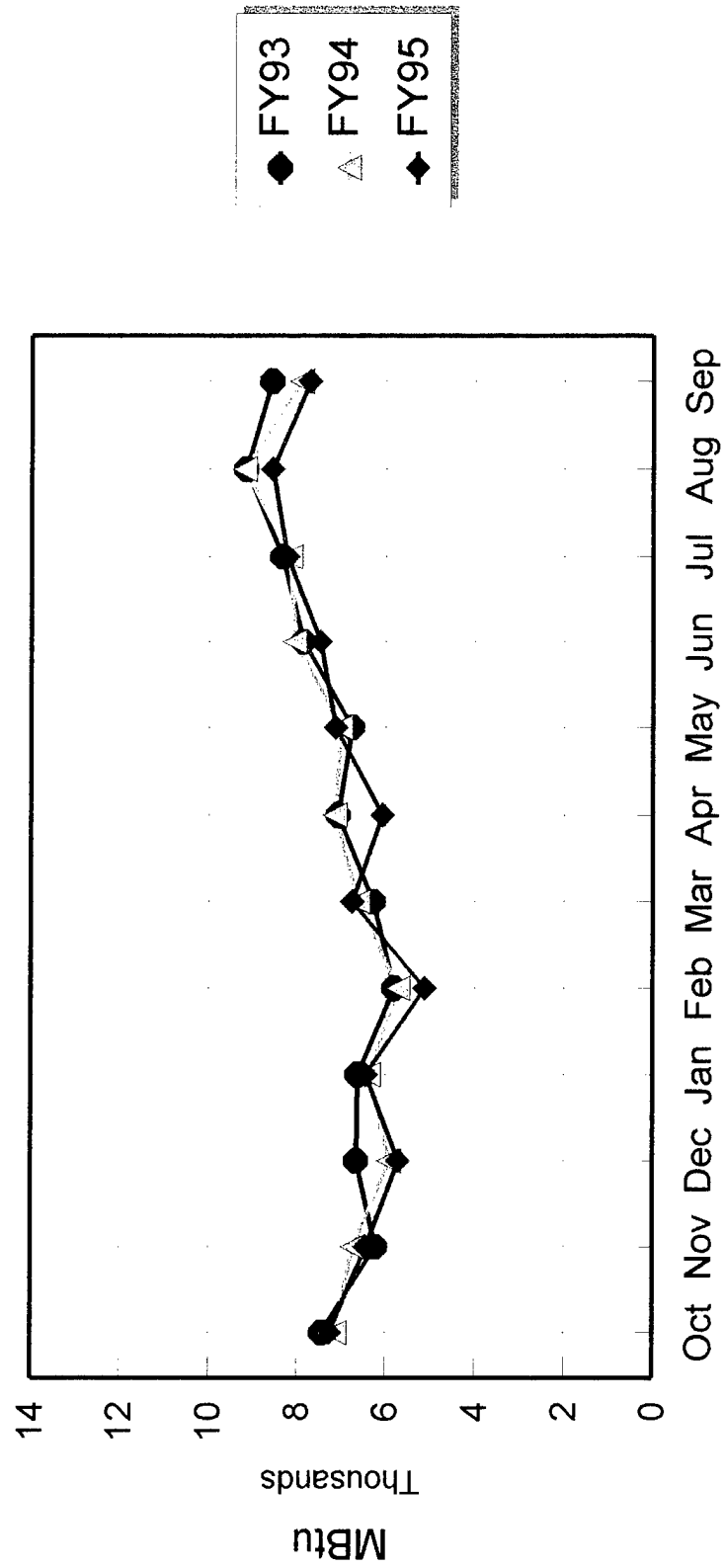

Figure 2.3-1

# EISENHOWER ARMY MEDICAL CENTER Historical Electricity Demand

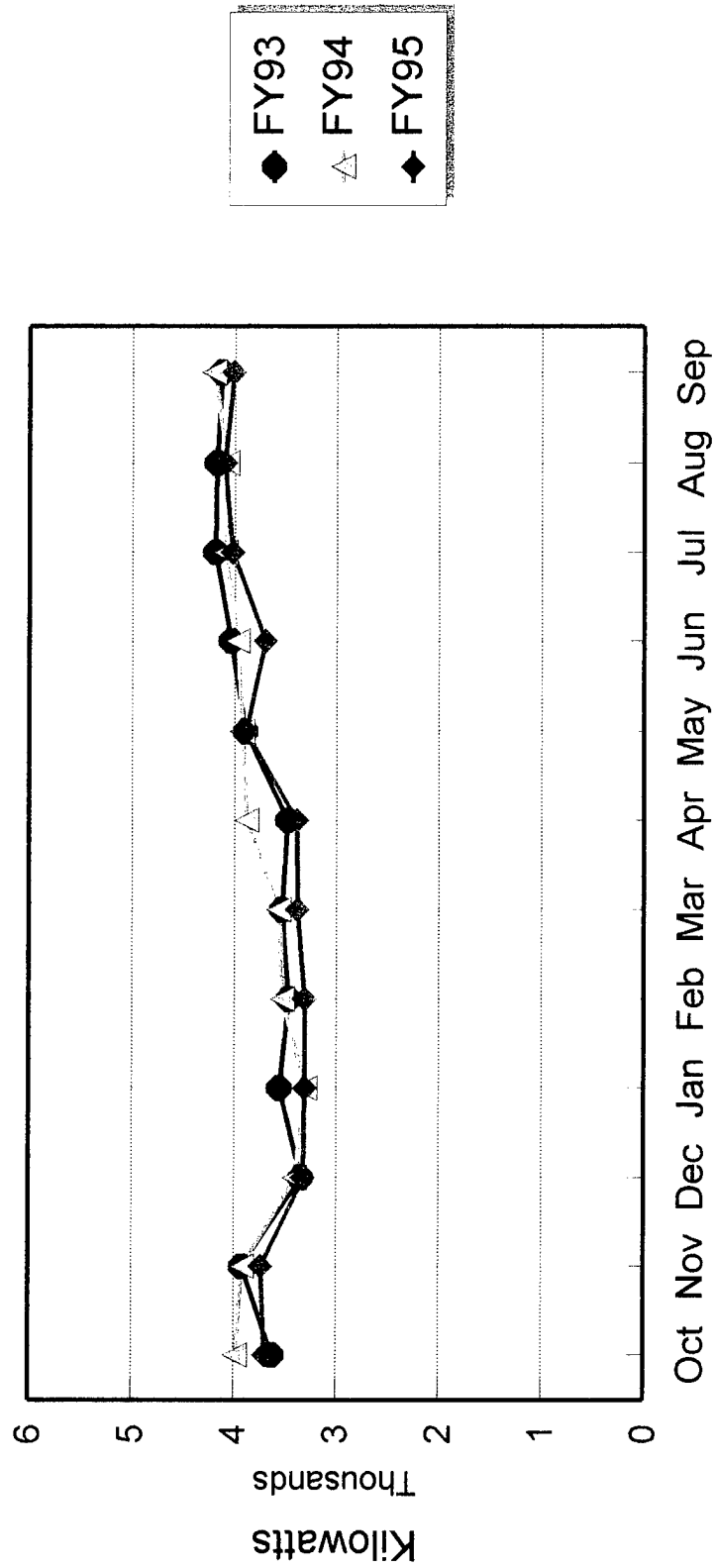

Figure 2.3-2

# EISENHOWER ARMY MEDICAL CENTER Historical Natural Gas Use

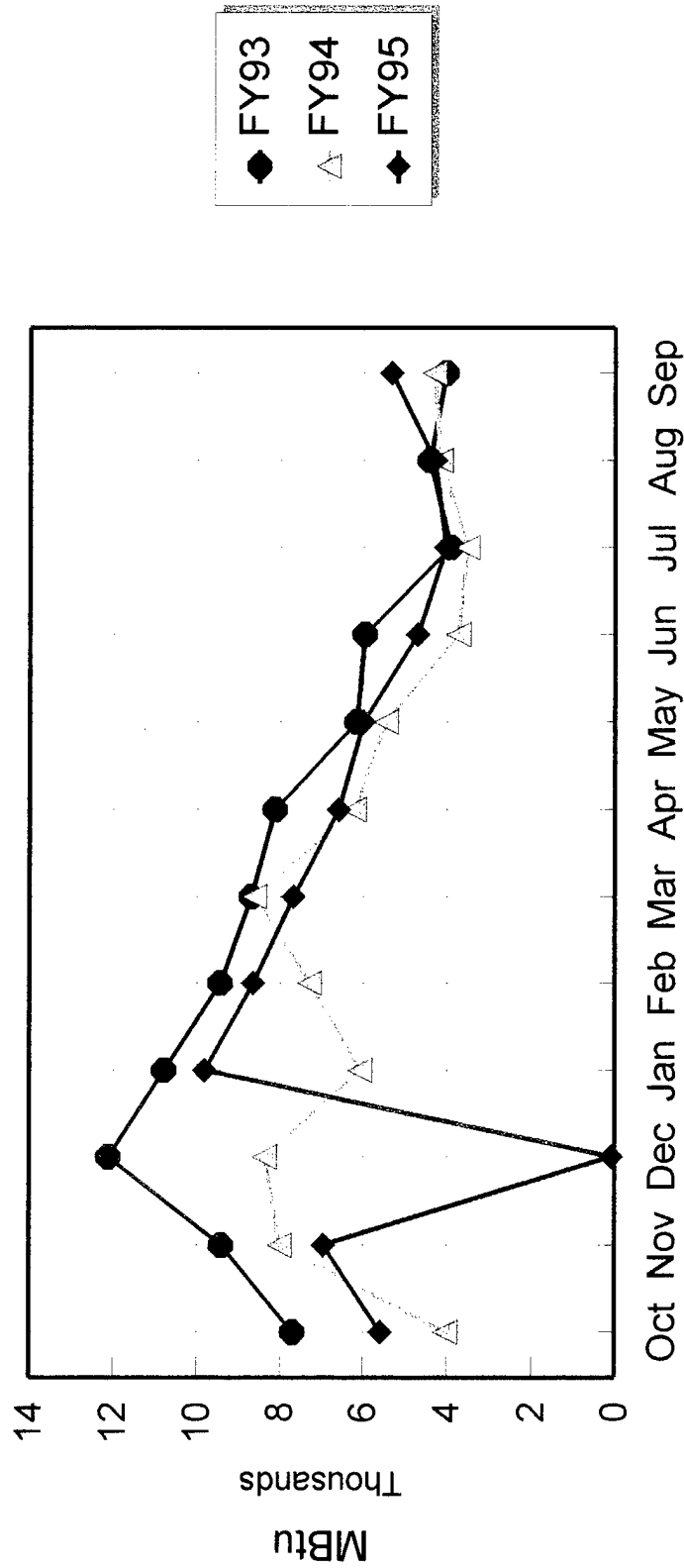
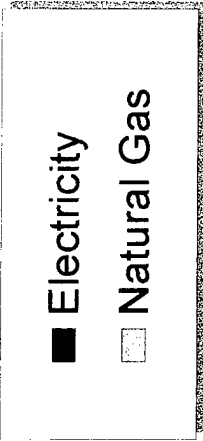
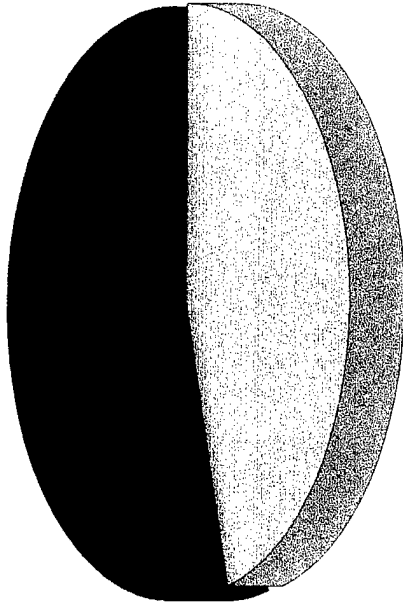

Figure 2.3-3

# EISENHOWER ARMY MEDICAL CENTER

Energy Use by Fuel - FY 95

(54.3%)



(45.7%)

Electricity	82,924	MBtu
Natural Gas	69,696	MBtu
Total	152,619	MBtu
EUI	242	kBtu/sf

Figure 2.3-4

# EISENHOWER ARMY MEDICAL CENTER Historical Utility Consumption

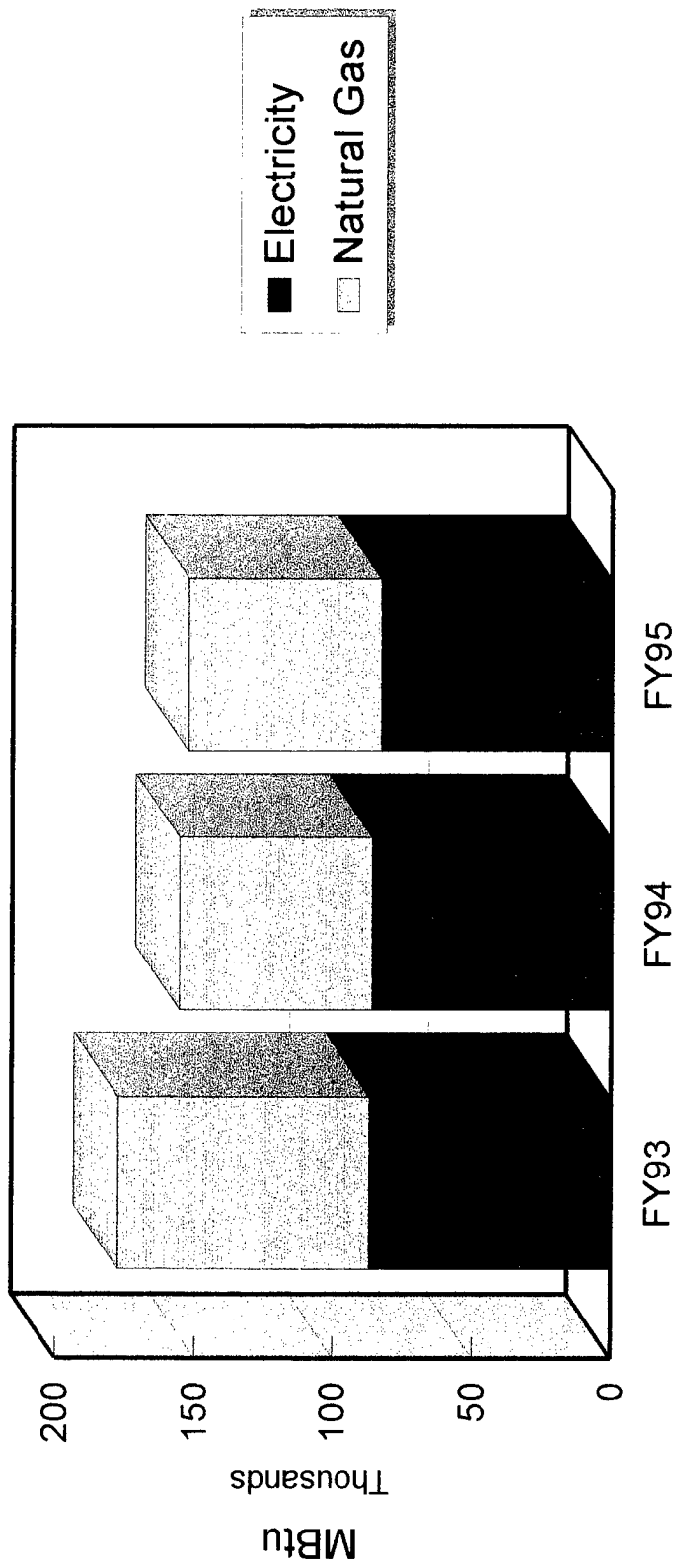
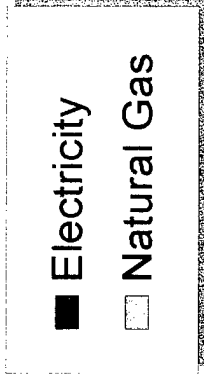
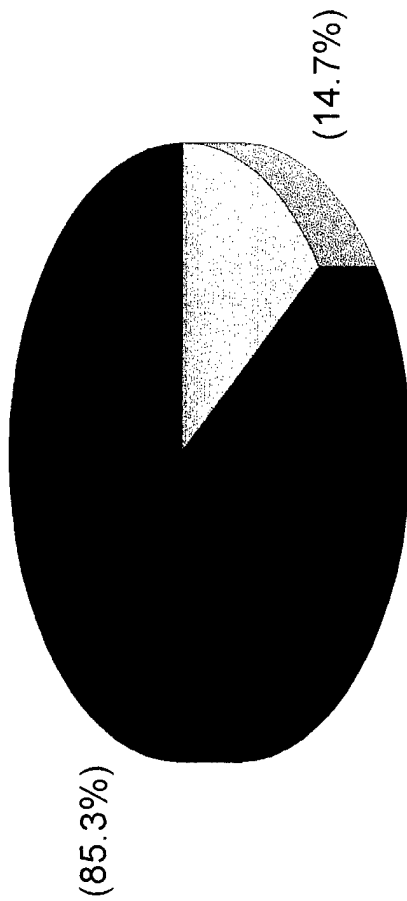

Figure 2.3-5

# EISENHOWER ARMY MEDICAL CENTER

Energy Cost by Fuel - FY 95



Electricity	\$ 1,080,300
Natural Gas	\$ 186,500
Total	\$ 1,266,800
ECI	\$2.01 /sf

Figure 2.3-6

# EISENHOWER ARMY MEDICAL CENTER Historical Utility Costs

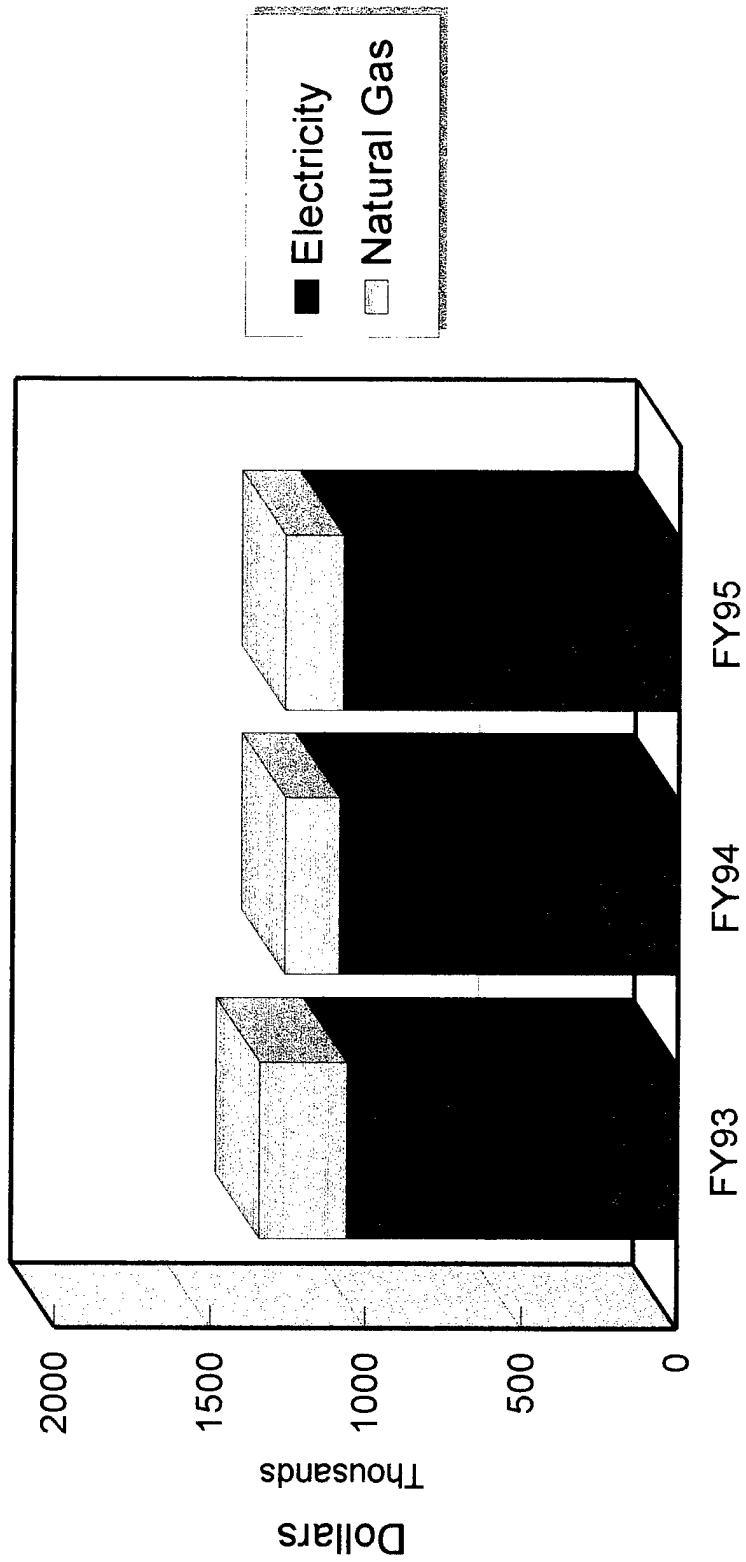

Figure 2.3-7

### 3.0 METHODOLOGY

#### 3.1 ANALYSIS TOOLS

The type of analysis used to evaluate the various ECOs will vary with the complexity of the ECO. There are three types of energy analysis software that will be used on this project. These are:

- Lotus 1-2-3®, Release 5
- TRACE 600® Ver. 13.04
- LCCID Ver. 1.0 Level 92

Lotus 1-2-3® is a spreadsheet program preferred by Fort Gordon DPW. RS&H uses this program for energy data analysis and to calculate energy savings for the less complex ECOs.

TRACE 600® is a computer simulation program developed by the TRANE company. It makes hourly calculations to provide building energy use values for space heat and cooling, lighting and other energy using equipment. TRACE 600® can compute energy use of the most complex ECOs that interact with other building systems. Examples of ECOs that may request use of this program are:

- thermal energy storage
- cooling tower retrofits
- peak shaving strategies
- supply air reset
- variable air volume system

Life Cycle Costing in Design (LCCID) is a life cycle cost analysis program developed by Construction Engineering Research Laboratory (CERL) for analysis of DoD energy saving projects. The Level 92 version contains the latest discount factors and fuel escalation rates provided by DOE.

#### 3.2 UTILITY RATES AND COST ESTIMATE ADJUSTMENTS

##### Utility Rates

The following utility rate information was used on this project.

Electricity

Average Energy .....	\$0.045/kWh (\$13.04/MBtu)
Peak Demand .....	\$0.80/kW (Summer only)
Energy, Incremental	
Winter .....	\$0.022/kWh (6.45/MBtu)
Summer .....	\$0.035/kWh (\$10.25/MBtu)
Weighted Average (four months summer, eight months winter)	
.....	\$0.026/kWh (\$7.62/MBtu)

Natural Gas ..... \$2.70/MBtu

Summer months - June through September

Winter months - All others

Electricity is provided by Georgia Power and natural gas by the Atlanta Gas Light Company. Neither utility offers rebates for energy or demand reduction projects. The EAMC is on a combination of two rates: PLL-2 (Power and Light Large) and SE-7 (Supplemental Energy). The PLL tariff has a declining block structure based on kWh/kW or load factor.

Load factor is the ratio of the kilowatt hours used during the month to the peak demand (in kW) times the hours in the month shown in the equation below:

$$\text{Load Factor} = \frac{E}{D \times H}$$

Where

E = monthly electricity use (kWh)

D = peak demand (kW)

H = hours in month (hrs)

Load factor is a measure of the consistency of the electricity demand or "load" on the utility each month. If the demand is constant, the load factor is 1.00. As the demand drops from its peak, the load factor decreases.

The PLL rate applies to all electricity usage during winter months and summertime electricity usage below the contracted amount of 2,960 kW. SE charges apply to electricity purchases above 2,960 kW which are 3.5 cents/kWh for electricity and \$0.80 per kW. The SE rate customers must reduce their demand to the billing demand (2,960 kW for EAMC) upon the request of Georgia Power Company. EAMC accomplishes this by activating two on-site generators (800 kW and 2,100 kW). The 2,960 kW demand is easily met since the EAMC all-time peak is only 4,201 kW. This requires a reduction of only 1,241 kW.

Table 3.2-1 below shows how the price for electricity purchases varies with load factor.

**Table 3.2-1. Electricity Rates Versus Load Factor**

<u>Winter</u>		<u>Summer</u>	
<u>Load Factor</u>	<u>Rate (¢/kWh)</u>	<u>Load Factor</u>	<u>Rate (¢/kWh)</u>
<0.001	12.56	<0.001	12.56
<0.003	11.56	<0.003	11.56
<0.007	10.11	<0.007	10.11
<0.21	8.18	<0.21	8.18
<0.42	2.65	<0.42	2.65
<0.64	2.41	<0.62	2.41
>0.64	2.16	<0.70	2.16
		>0.70	3.48

Historically, load factors at EAMC vary from 0.65 in the winter to 0.90 in the summer and average 0.76 year round. Since the EAMC load factor rarely drops below 0.64 in the winter or 0.70 in the summer, the marginal electricity rates are:

June - September	3.5¢/kWh
All other months	2.2¢/kWh
Annual Weighted Average	2.6¢/kWh
FY 95 Actual Average	4.5¢/kWh

The EAMC has never failed to meet a curtailment request since contracting this rate eight years ago. Typically, 30 to 40 hours of on-site generation are required to meet the contract requirements. This past year, the requests were unusually high, about 76 hours. However, should the EAMC fail to meet the curtailment request, there is a substantial penalty. The demand charge portion for the PLL rate would come into effect, which is \$8.00 per kW with a 95 percent ratchet of the summer peak. If the EAMC failed to reduce its kW to the billing demand, this would require paying a one-time charge at \$8.00/kW for demand in excess of 2,960 kW and 95 percent of that for the next 11 months. For a typical summer time demand of 4,000 kW, this would result in \$8,000 additional charges for that month and \$83,600 over the next 11 months, for a total cost of \$91,600.

#### **Cost Estimate Adjustments**

The labor rates for all cost estimates were taken from 1996 Means Cost Data Books. Adjustments to cost estimates are shown in Table 3.2-2.

**Table 3.2-2. Cost Estimate Adjustments**

<u>Adjustments</u>	Labor	Material
Contingency	10.0%	
Sales Tax	N.A.	6.0%
FICA/Insurance	20.0% <sup>(1)</sup>	N.A.
Overhead	15.0% <sup>(1)</sup>	
Profit	10.0% <sup>(1)</sup>	
Performance Bond	1.0% <sup>(1)</sup>	
SIOH	6.0%	
Design Fees	6.0%	

(1) Product yields labor increase = 53 percent.

### **3.3 COMPUTER MODEL**

A computer model of the EAMC energy consumption was developed using TRANE's TRACE 600® energy analysis software. The baseline model was refined to closely match the energy use for FY95. An average value was substituted for December when fuel oil was used exclusively. As discussed in Section 2.3, electricity use for the three fiscal years has changed little. Natural gas use for FY95 was between that of FY94 and FY93, so this was not an extreme weather year. The results of the model calculations are shown in Table 3.3-1 and Figures 3.3-1, 3.3-2 and 3.3-3 which compare historical values with kilowatt hour use, electricity demand and natural gas use, respectively. Annual energy use calculations by the model were within five percent of the actual metered figures. The computer simulation results show that the Renovation Project should reduce electricity energy use by 9.0 percent and natural gas use by 20.2 percent. These are annual cost reductions of nearly \$100,000 per year. The model predicted peak heating and cooling loads of 12,000,000 Btu/hour and 1,600 tons, respectively. From this baseline, estimates of energy use by system were calculated. The results are shown in Figures 3.3-4, 3.3-5, 3.3-6 and 3.3-7.

A second model was developed to characterize the impact of the FY96 Renovation Project discussed in Section 2.1. Comparison between the baseline electricity use, electricity demand and natural gas use are shown in Figures 3.3-8, 3.3-9 and 3.3-10. Energy reductions are about ten percent for both electricity and natural gas use. This model is the baseline for all ECO evaluations.

# Eisenhower Army Medical Center Comparison with Model - kWh

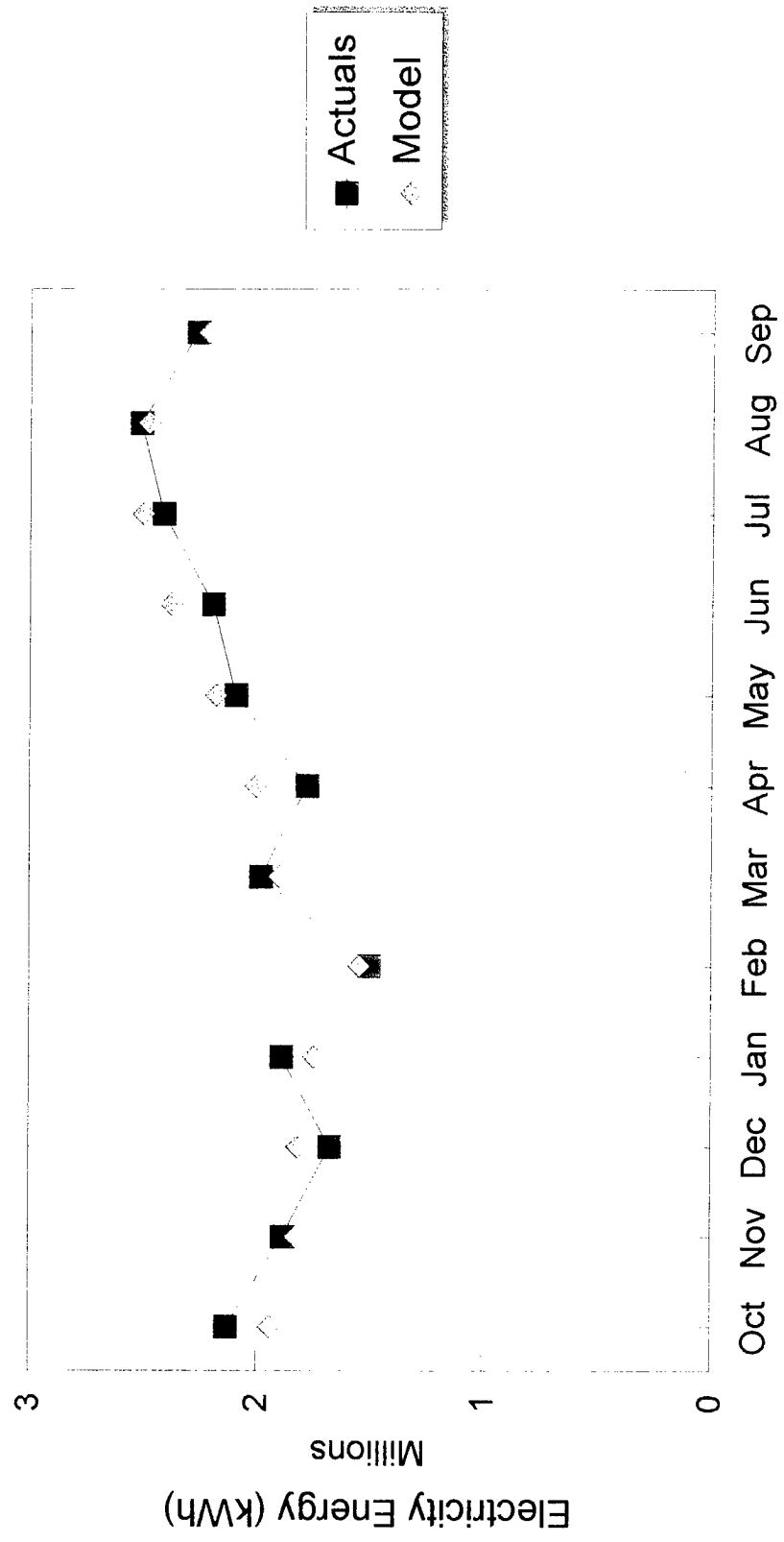

Figure 3.3-1

# Eisenhower Army Medical Center Comparison with Model - kW

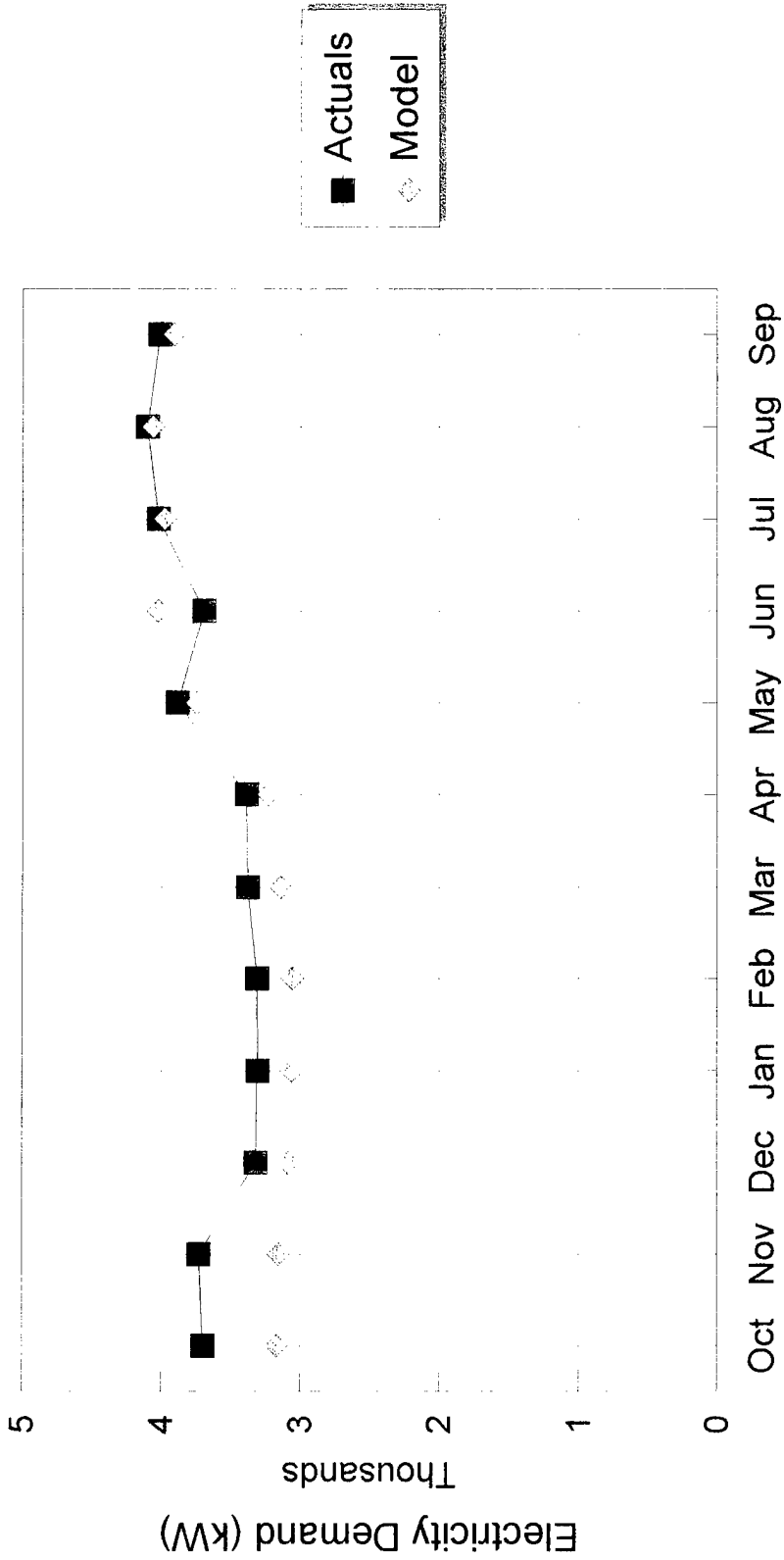

Figure 3.3-2

# Eisenhower Army Medical Center Comparison with Model - Nat Gas

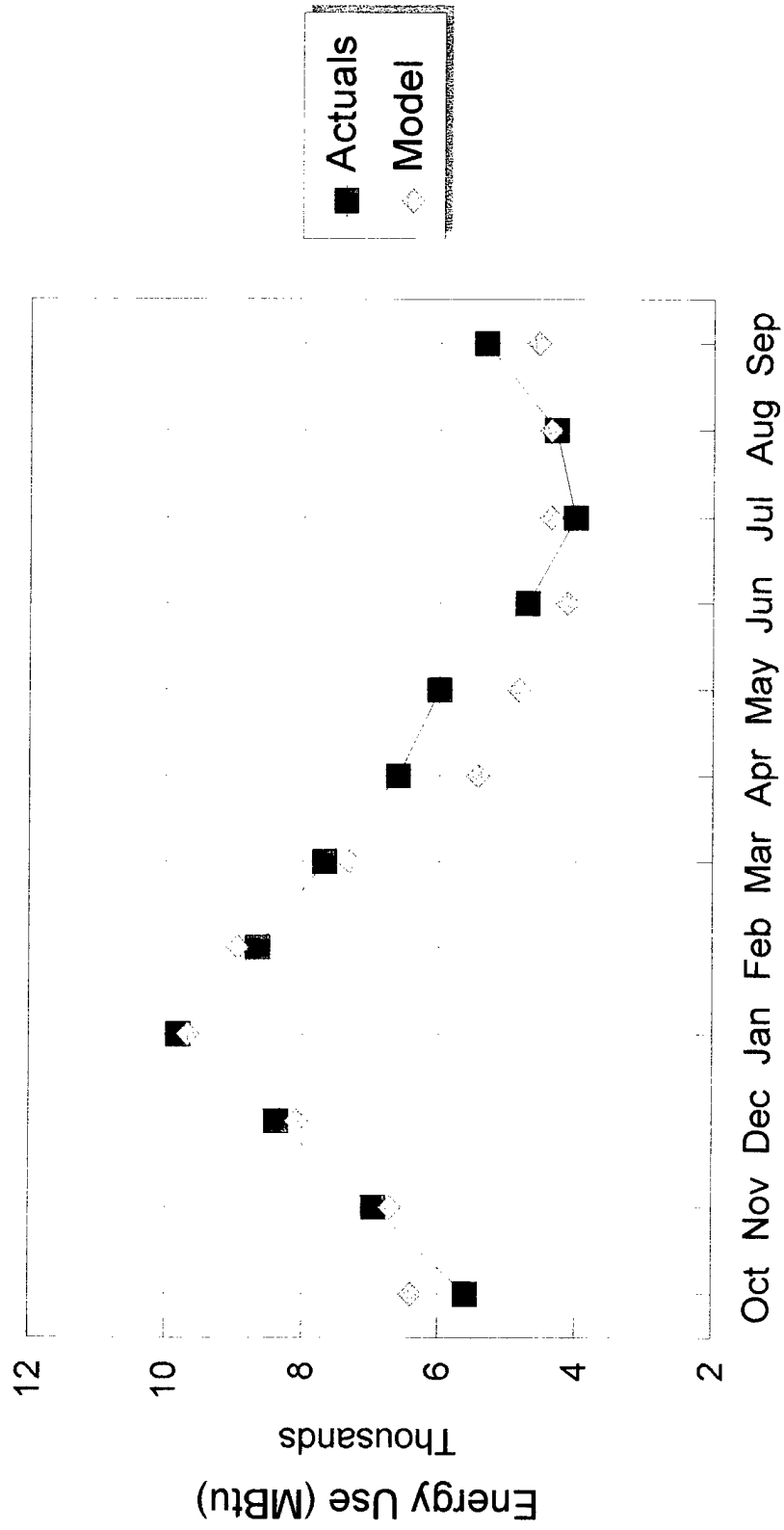
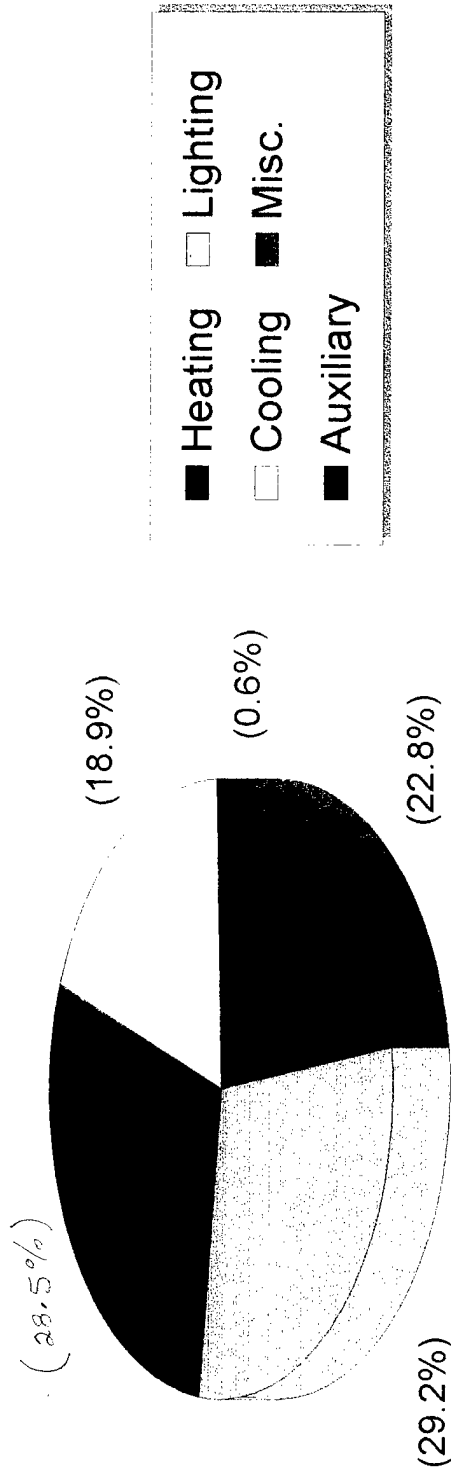

Figure 3.3-3

# EISENHOWER ARMY MEDICAL CENTER

## Energy Use by System - Electricity



0.6  
 18.9  
 22.8  
 28.5  
 29.2

Figure 3.3-4

# EISENHOWER ARMY MEDICAL CENTER

## Energy Use by System - Natural Gas

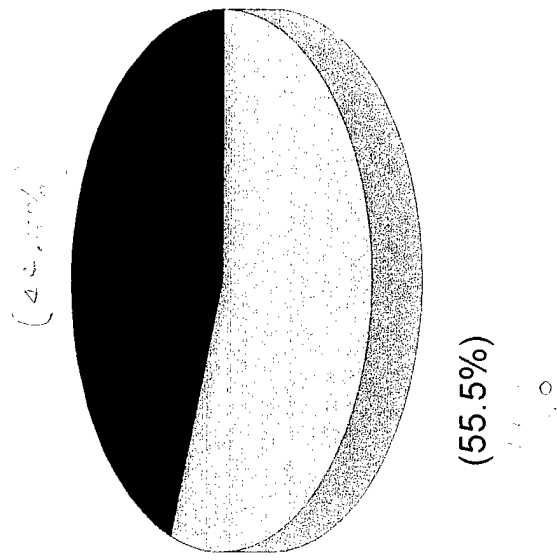

■ DHW  
□ Heating

Figure 3.3-5

# EISENHOWER ARMY MEDICAL CENTER

Energy Use by System - All Fuels

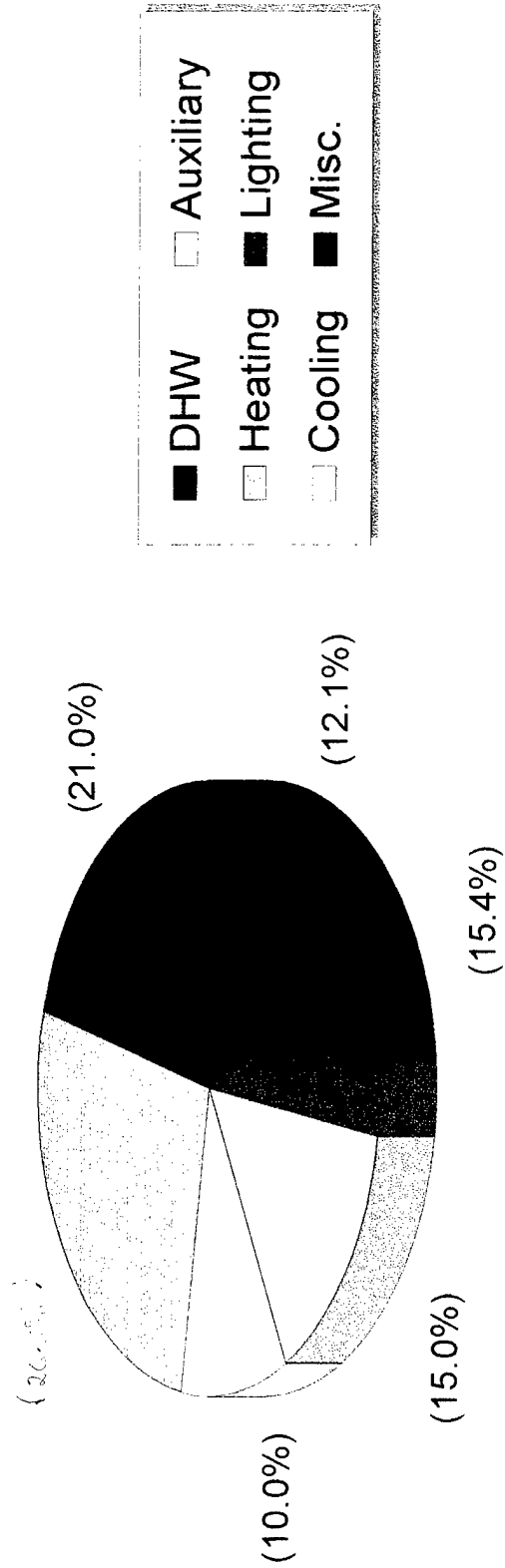
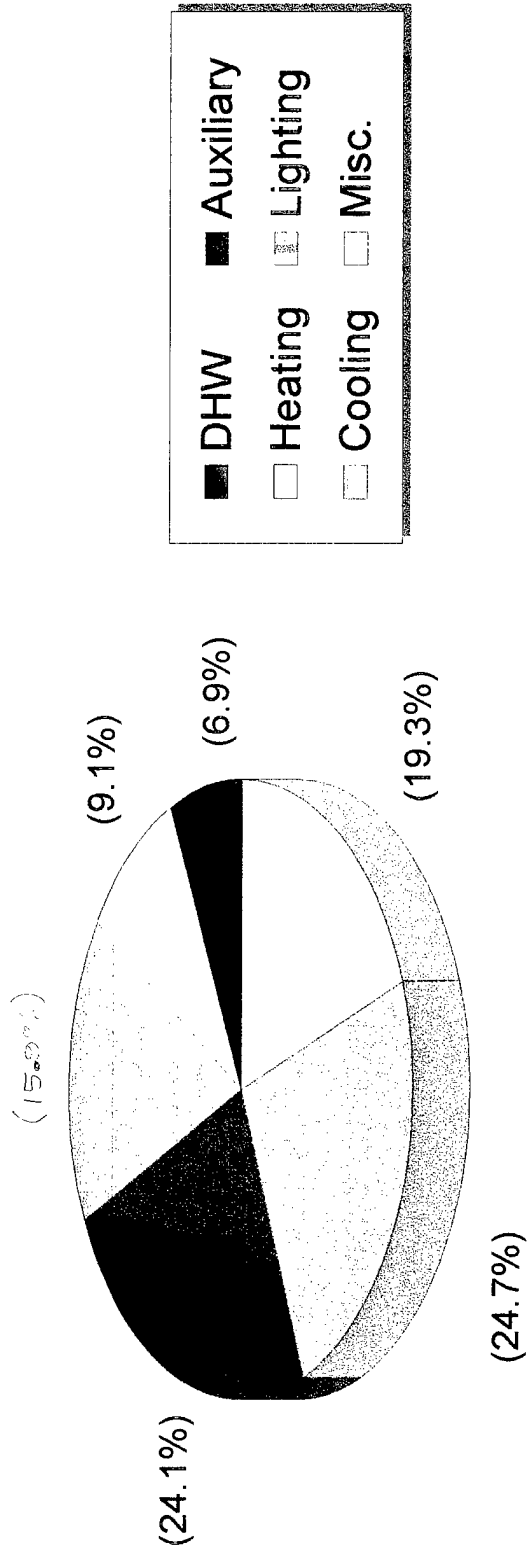

Figure 3.3-6

# EISENHOWER ARMY MEDICAL CENTER

## Energy Cost by System - All Fuels



24.1  
 6.9  
 9.1  
 19.3  
 24.7  
 24.7  
 94.1

Figure 3.3-7

# Eisenhower Army Medical Center Before and After Renovation - kWh

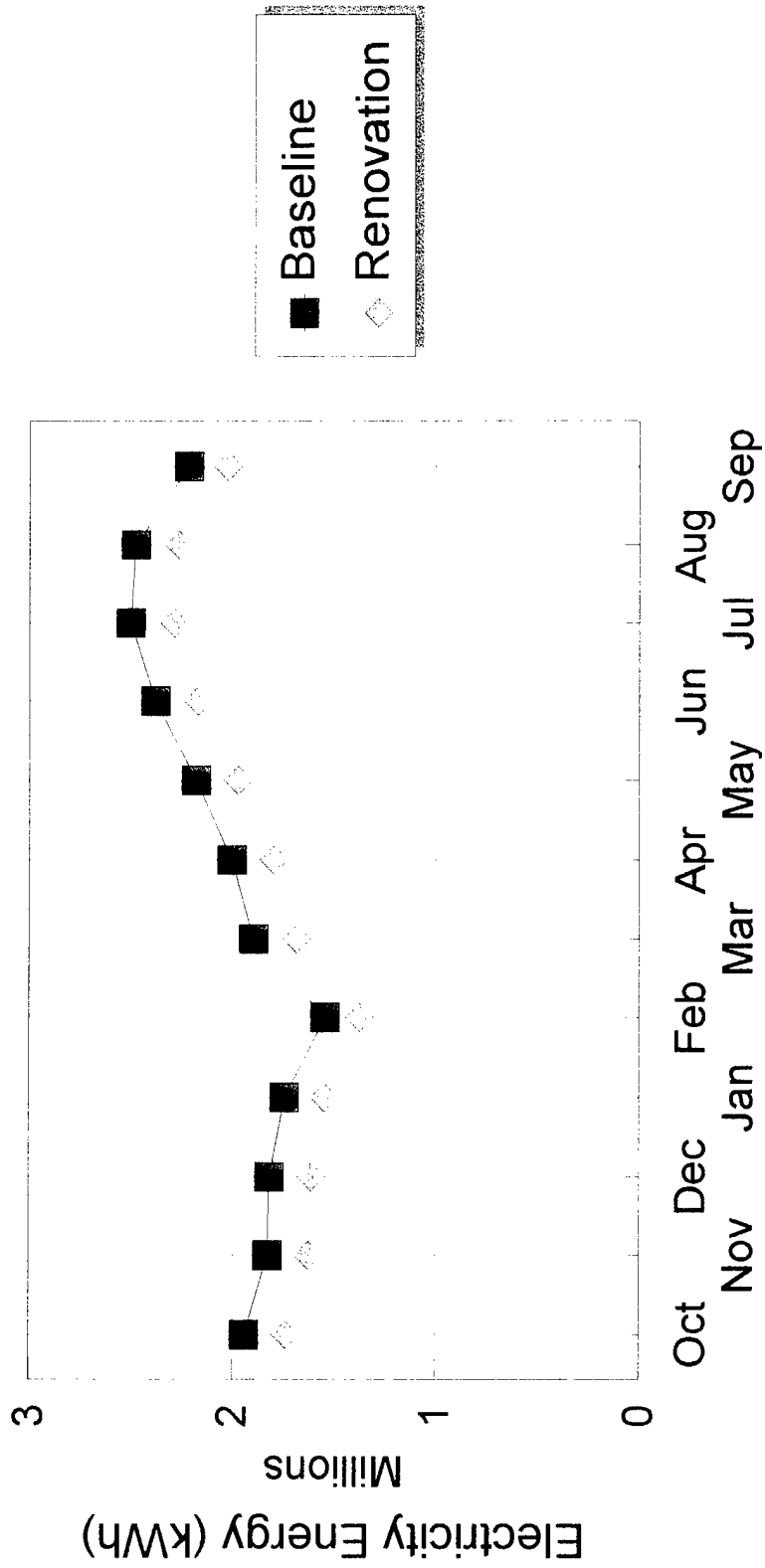

Figure 3.3-8

# Eisenhower Army Medical Center Before and After Renovation - kW

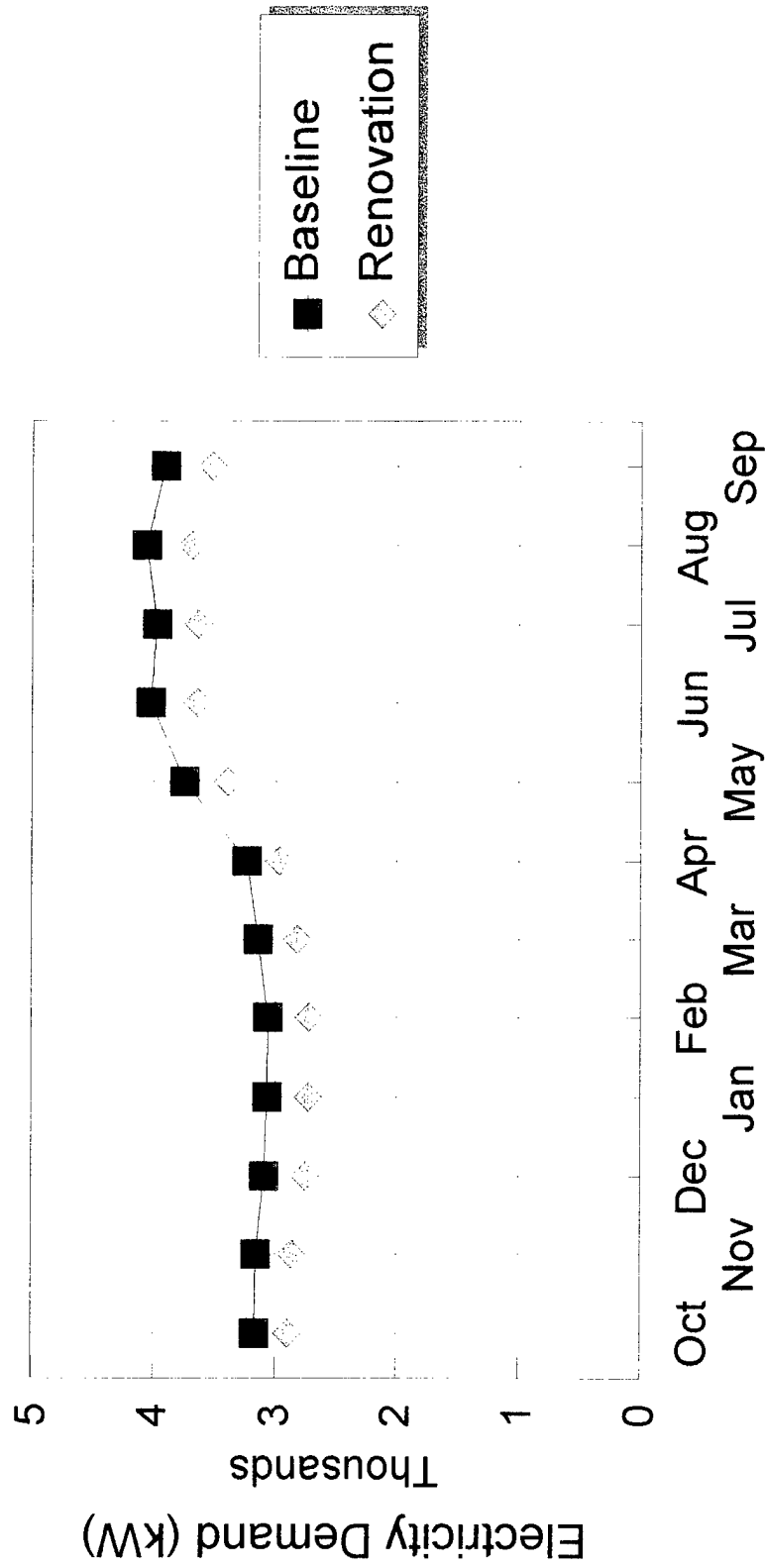

Figure 3.3-9

# Eisenhower Army Medical Center Before and After Renovation - Nat Gas

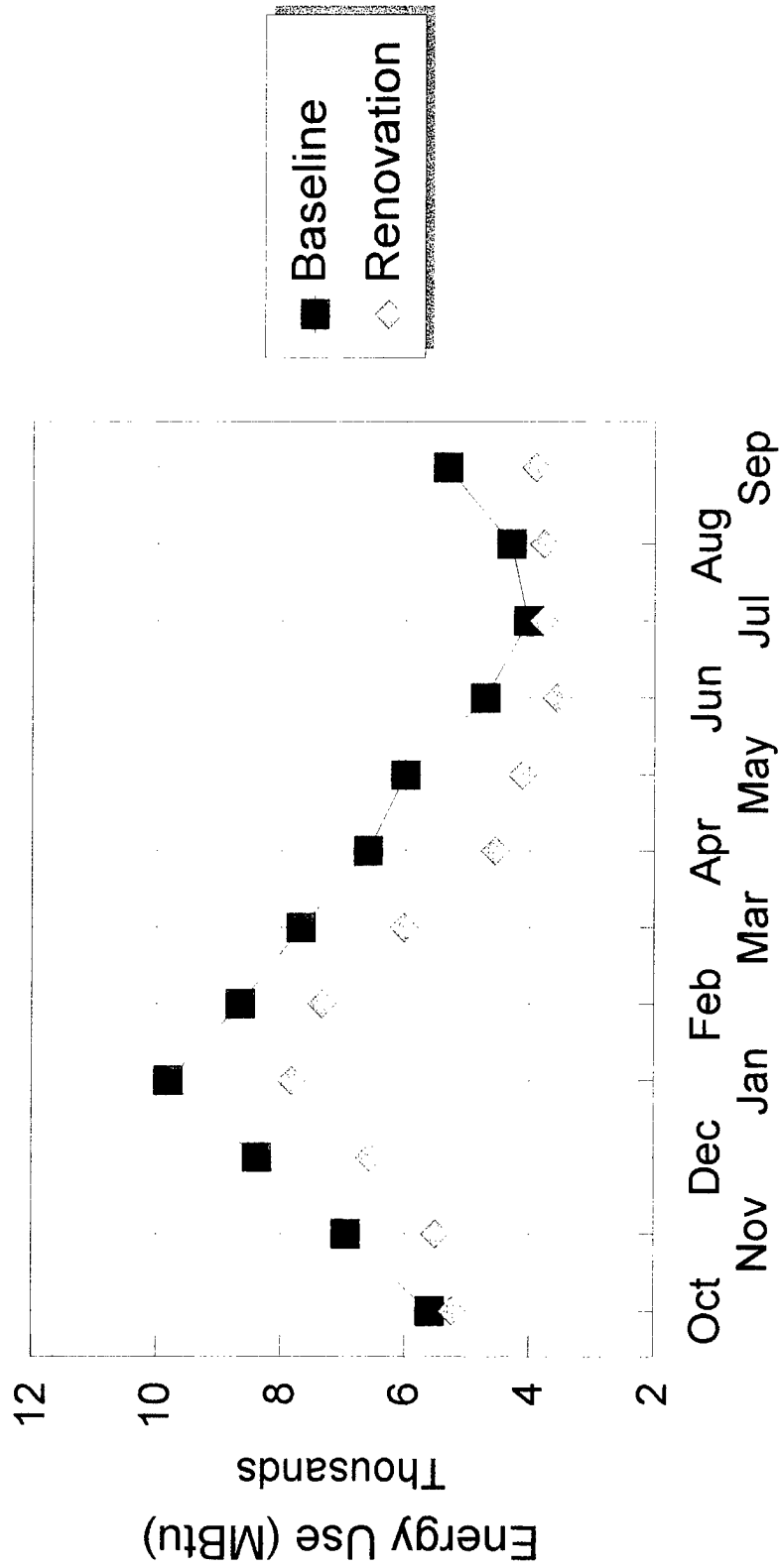

Figure 3.3-10

**Table 3.3-1 Computer Simulation Results**

Description	Electricity		Natural Gas	
	(kWh/yr)	Difference	(MBtu/yr)	Difference
Metered (FY95)	24,296,400		78,011	
Baseline (2)	24,538,100	1.0% (2)	74,850	-4.0%
After RP (1) (2)	22,118,900	-9.0% (3)	62,200	-20.2%
Cost Savings for RP	\$56,900		\$42,500	
TOTAL	\$99,400			

(1) FY96 Renovation Project and T-8 lamping.

(2) Baseline model relative to metered.

(3) Renovation Project model relative to baseline.

Details of the two models are contained in Volume II. Input echos plus selected outputs can be found there. All ECO evaluations are performed using the second model which contains the improvements funded by the FY96 Renovation Project.

## 4.0 ANALYSIS

### 4.1 ENERGY CONSERVATION OPPORTUNITY (ECO) EVALUATIONS

The applicability for further study was evaluated for each of the ECOs listed in the scope of work and others added later as a result of the field investigations. A summary of this evaluation is contained in Table 4.1-1.

A detailed analysis was performed for each of those ECOs which were designed to be "evaluated". All analyses were performed assuming that the FY96 Renovation Project and ongoing T-8 retrofit project were completed. However, between the Interim and Prefinal Submittals, the renovation project was expanded to include replacement of all three boilers and associated controls. Therefore, some boiler improvement ECOs were evaluated but are not recommended. If the ECO failed to pay back within ten years, it will not qualify for funding. However, some ECOs that are unlikely to pay back within ten years, such as those involving substantial cost in replacing functioning equipment, are also discussed in this section. Projects that have already been funded as part of the FY96 Renovation Project are so noted. Operation and Maintenance (O&M) projects are described in Section 4.3.

The results of the detailed analyses are summarized in Tables 4.1-2, 4.1-3, and 4.1-4. Table 4.1-2 contains the evaluated ECOs in alphabetical order by ECO ID. Tables 4.1-3 and 4.1-4 display the results ordered by SIR and by payback, respectively.

Table 4.1-5 lists those ECOs qualifying for funding. These ECOs have SIRs greater than 1.25 and paybacks less than ten years. Those ECOs not meeting these requirements are listed in Table 4.1-6. Detailed calculations, cost estimates and Life Cycle Cost Analysis results are located in Volume II, Appendices.

An Energy Management Control System was not evaluated since the FY96 Renovation Project includes a new Plant Management System which encompasses the central heating and cooling plant and the hospital.

TABLE 4.1-1 POTENTIAL ENERGY CONSERVATION OPPORTUNITIES  
 EISENHOWER ARMY MEDICAL CENTER  
 FORT GORDON, GA

ECO ID	ECO DESCRIPTION	EVALUATED	COMMENTS
<b>Building Envelope</b>			
BE1	Reduce infiltration by caulking and weatherstripping		See text - Section 4.3, p.4-54
BE2	Install insulated glass or double-glazed windows	X	
BE3	Install roof insulation		Very well insulated, U = 0.058
BE4	Install vestibule dock seals		NA
BE5	Install loadings on entrances		See discussion in this section
BE6	Install solar shading, screening, curtains or blinds		NA - exists
BE7	Install wall insulation		Well insulated, U = 0.068
BE8	Install low emissivity windows		Windows have shades/drapes
<b>Boiler Plant</b>			
BP1	Reduce steam distribution pressure	X	
BP2	Shut off steam to laundry when not in use		NA - No laundry
BP3	Increase boiler efficiency	X	
BP4	Repair, replace, or install condensate return system		See discussion in this section
BP5	Insulate boiler and boiler piping		See text, Section 4.3, p. 4-54
BP6	Repair and maintain steam lines and traps		See discussion in this section
BP7	Install economizer	X	
BP8	Install air preheater	X	
BP9	Check boiler water chemistry program		See Section 4.3, p. 4-54
BP10	Clean boiler tubes		Boiler tubes in good condition
BP11	Install blowdown controls		See discussion in this section
BP12	Modify boiler and chiller controls	X	See BP3
BP13	Improve water treatment to prevent tube fouling		See BP9 - No problem with tubes
BP14	Install blowdown heat recovery		See discussion in this section
BP15	Install oxygen trim controls	X	
BP16	Install pony boiler		See discussion in this section
BP17	Install new unattended boilers	X	
<b>Chiller Plant</b>			
CP1	Repipe chiller to a common manifold		NA - exists
CP2	Install multispeed/variable speed cooling tower fans		Renovation Project
CP3	Replace absorption chillers with centrifugal chillers		Absorption chiller to be used for peak shaving
CP4	Reduce condensate water temperature		Renovation Project
CP5	Shut off unneeded circulating pumps		Renovation Project
CP6	Reduce chilled water flow during light loads		Renovation will make prim/sec pumping system
CP7	Shed loads during peak electrical demand periods		NA - Not practical at hospital
CP8	Raise chilled water temperature		Renovation Project
CP9	Install high efficiency chiller		Renovation Project
<b>Electrical Equipment</b>			
EL1	Shut off elevators whenever possible		NA - Not practical at hospital
EL2	Shut off pneumatic tube system whenever possible		NA - Not practical at hospital
EL3	Install capacitors or synchronous motors to increase power factor	X	
EL4	Use emergency generator to reduce peak demand	X	
EL5	Shed or cycle electrical loads to reduce peak demand		NA - Not practical at hospital
EL6	Convert to energy efficient motors	X	
EL7	Install variable volume pumping		Renovation Project

**Heating, Ventilation and Air Conditioning - Systems**

HS1	Use dry bulb economizers		Renovation Project
HS2	Reduce reheating of cooled air	X	See HS7
HS3	Use energy recovery units	X	
HS4	Use hot and cold deck temperatures reset		Renovation Project
HS5	Maintain filters		Well maintained
HS6	Clean coils		Renovation Project
HS7	Install variable air volume controls	X	
HS8	Insulate ducts and piping		See text - Section 4.3, p. 4-54
HS9	Eliminate simultaneous heating and cooling	X	See HS7
HS10	Install night setback controls		Renovation Project
HS11	Replace over-sized motors		See discussion in this section
HS12	Replace hand valves with automatic ones		NA
HS13	Use damper controls to shut off air to unoccupied areas	X	
HS14	Shut off or reduce speed of room fan coil units		NA
HS15	Shut off or reduce stairwell heating		NA - no overheating, minimal savings
HS16	Reduce AHU air volumes		See discussion in this section
HS17	Shut off AHU's whenever possible		Renovation Project
HS18	Reduce heated or cooled OSA	X	
HS19	Reduce humidification to minimum requirements		Current setting is 40%, below 50% requirement
HS20	Reduce pumping flow		Renovation Project
HS21	Repair and/or maintain AHU controls		Renovation Project
HS22	Cycle fans and pumps		Renovation Project
HS23	Reset thermostats to design requirements		See text - Section 4.3, p. 4-54
HS24	Reset surgical suite supply air	X	

**Kitchen**

KI1	Shut off range hood exhaust whenever possible		Renovation Project
KI2	Install high efficiency steam control valves		NA
KI3	Shut off equipment and appliances whenever possible		See text - Section 4.3, p. 4-54
KI4	Install makeup air supply for exhaust		NA - exists
KI5	Install heat reclamation system for exhaust heat	X	
KI6	Turn off lights in coolers		See text - Section 4.3, p. 4-54
KI7	Install heat pump water heater		NA - Only practical for residential
KI8	Install energy efficient exhaust hoods	X	

**Lighting**

LT1	Shut off lights when not needed		See text - Section 4.3, p. 4-54
LT2	Reduce lighting levels	X	
LT3	Revise cleaning schedules		NA
LT4	Convert to energy efficient lighting systems	X	
LT5	Install reflectors in fluorescent fixtures		See discussion in this section
LT6	Install separate lighting switching		No large-scale applications
LT7	Analyze the effects of harmonics for electronic ballast system		See text - Section 4.3, p. 4-54

**Miscellaneous**

MI1	Install computerized EMCS		Renovation Project
MI2	Convert steam-driven turbine motors to electric		NA
MI3	Install occupancy sensors to control lighting or HVAC	X	
MI4	Use natural gas technology to reduce peak demand, such as Desiccant cooling	X	
MI5	Direct-fired, double-effect absorption chiller		Renovation Project
MI6	Convert to Real-Time Pricing electricity rate		See discussion in this section

**Plumbing**

PL1	Reduce domestic hot water temperature		Current setting is appropriate - 115 F
PL2	Repair and maintain hot water and steam piping insulation		See text - Section 4.3, p. 4-54
PL3	Install flow restrictors		NA - More useful for showers
PL4	Install automatic shut off faucets		NA - No problem exists
PL5	Decentralize hot water heating		Impractical
PL6	Add pipe insulation		See text - Section 4.3, p. 4-54

BP16, BP17, CP9, HS24 and MI6 were added as a result of field investigations.

Table 4.1-2 ECO Evaluations Summary - Ordered by ECO ID

No.	ECO ID	Description	Construction Cost	Energy Elec.	Annual Savings Energy (MBtu/yr)	Annual Savings NGas	O&M	Annual Cost Savings	SIR	Simple Payback (yrs)
1	BE2	Install insulated glass or double-glazed windows	\$242,000	2	62	-	-	\$200	0.0	999
2	BP1	Reduce steam distribution pressure from 60 to 30 p	\$25,800	(2,413)	3,432	-	-	(\$9,100)	0.0	999
3	BP3	Increase boiler efficiency (repair controls)	\$24,000	-	6,706	-	-	\$18,100	11.6	1.5
4	BP7	Install economizer	\$104,100	(82)	3,691	-	-	\$9,300	1.4	12.5
5	BP8	Install air heater	-	(82)	3,691	-	-	\$9,300	0.0	999
6	BP15	Install oxygen trim controls	\$9,900	-	640	-	-	\$1,700	2.7	6.4
7	BP16	Install pony boiler	\$100,600	-	517	-	-	\$1,400	0.2	80.7
8	BP17	Install new unattended boilers	\$427,800	-	8,971	\$120,000	-	\$144,200	4.1	3.3
9	EL3	Increase power factor	\$76,800	-	-	-	-	\$4,900	0.7	17.8
10	EL4	Use emergency generator to reduce demand	\$182,400	15	(416)*	\$65,200	-	\$67,900	3.0	4.3
11	EL6	Convert to energy efficient motors	\$17,200	284	-	-	-	\$2,200	1.5	8.9
12	HS7	Install variable air volume controls	\$329,600	2,472	1,880	-	-	\$23,900	0.9	15.4
13	HS13	Use damper controls to shut off air to unoccupied ar	\$111,500	2,041	1,505	-	-	\$19,600	2.3	6.4
14	HS18	Reduce heated or cooled outside air	\$1,100	136	32	-	-	\$1,100	12.7	1.1
15	HS24	Surgical suite supply air reset	\$1,400	738	1,984	-	-	\$11,000	108.0	0.1
16	KI5	Install heat reclamation system for exhaust heat	\$87,700	(395)	2,630	-	-	\$4,100	0.8	24.0
17	KI8	Install energy efficient kitchen exhaust hoods	\$138,700	(532)	4,032	-	-	\$6,800	0.9	22.7
18	LT2	Reduce lighting levels	\$5,500	1,158	-	-	-	\$8,800	19.6	0.7
19	LT4A1	Retrofit with T-8s & elect. ballasts - hallways/100	\$5,900	90	-	-	-	\$700	1.4	9.6
20	LT4A2	Retrofit with T-8s & elect. ballasts - patient rooms/1	\$5,900	60	-	-	-	\$450	1.0	14.5
21	LT4A3	Retrofit with T-8s & elect. ballasts - offices/100	\$5,900	27	-	-	-	\$200	0.4	32.1
22	LT4B1	Replace MVs with T-8 fixtures	\$830	4	-	\$9	-	\$42	0.6	22.3
23	LT4B2	Replace MVs with metal halides	\$3,150	12	-	(\$80)	-	(\$1,030)	0.1	308.3
24	LT4C1	Retrofit compact fluor's in restrooms.	\$37,500	231	-	\$8,500	-	\$10,300	3.3	4.0
25	LT4C2	Retrofit compact fluor's in lobby downlights.	\$1,100	13	-	\$500	-	\$600	6.6	2.0
26	M13A	Install occ. sensors to control lighting- restrooms/10	\$14,900	259	-	-	-	\$2,000	1.6	8.5
27	M13B	Install occ. sensors to control lighting-breakrooms.	\$1,900	999	-	-	-	\$7,600	4.9	2.8
28	M13C	Install occ. sensors to control lighting- offices/100	\$6,700	28	-	-	-	\$210	0.4	35.2
29	M13C	Install occ. sensors to control lighting- offices/100	\$6,600	62	-	-	-	\$500	0.9	15.7
30	M14	Natural gas desiccant cooling	\$176,900	833	(2,804)	-	-	(\$1,200)	-0.2	999

\* Fuel oil

Table 4.1-3 ECO Evaluations Summary - Ordered by SIR

No.	ECO ID	Description	Construction Cost	Energy Elec.	Annual Savings (MBtu/yr)	Annual Savings	Annual Cost Savings	SIR	Simple Payback (yrs)
1	HS24	Surgical suite supply air reset	\$1,400	738	1,984	-	\$11,000	108.0	0.1
2	LT2	Reduce lighting levels	\$5,500	1,158	-	-	\$8,800	19.6	0.7
3	HS18	Reduce heated or cooled outside air	\$1,100	136	32	-	\$1,100	12.7	1.1
4	BP3	Increase boiler efficiency (repair controls)	\$24,000	-	6,706	-	\$18,100	11.6	1.5
5	LT4C2	Retrofit compact fluor's in lobby downlights.	\$1,100	13	-	\$500	\$600	6.6	2.0
6	MI3B	Install occ. sensors to control lighting-breakrooms.	\$1,900	999	-	-	\$7,600	4.9	2.8
7	BP17	Install new unattended boilers	\$427,800	-	8,971	\$120,000	\$144,200	4.1	3.3
8	LT4C1	Retrofit compact fluor's in restrooms.	\$37,500	231	-	\$8,500	\$10,300	3.3	4.0
9	EL4	Use emergency generator to reduce demand	\$182,400	15	(416)*	\$65,200	\$67,900	3.0	4.3
10	BP15	Install oxygen trim controls	\$9,900	-	640	-	\$1,700	2.7	6.4
11	HS13	Use damper controls to shut off air to unoccupied areas	\$111,500	2,041	1,505	-	\$19,600	2.3	6.4
12	MI3A	Install occ. sensors to control lighting- restrooms/10	\$14,900	259	-	-	\$2,000	1.6	8.5
13	EL6	Convert to energy efficient motors	\$17,200	284	-	-	\$2,200	1.5	8.9
14	LT4A1	Retrofit with T-8s & elect. ballasts - hallways/100	\$5,900	90	-	-	\$700	1.4	9.6
15	BP7	Install economizer	\$104,100	(82)	3,691	-	\$9,300	1.4	12.5
16	LT4A2	Retrofit with T-8s & elect. ballasts - patient rooms/1	\$5,900	60	-	-	\$450	1.0	14.5
17	HS7	Install variable air volume controls	\$329,600	2,472	1,880	-	\$23,900	0.9	15.4
18	MI3C	Install occ. sensors to control lighting- offices/100	\$6,600	62	-	-	\$500	0.9	15.7
19	KI8	Install energy efficient kitchen exhaust hoods	\$138,700	(532)	4,032	-	\$6,800	0.9	22.7
20	KI5	Install heat reclamation system for exhaust heat	\$87,700	(395)	2,630	-	\$4,100	0.8	24.0
21	EL3	Increase power factor	\$76,800	-	-	-	\$4,900	0.7	17.8
22	LT4B1	Replace MVs with T-8 fixtures	\$830	4	-	\$9	\$42	0.6	22.3
23	LT4A3	Retrofit with T-8s & elect. ballasts - offices/100	\$5,900	27	-	-	\$200	0.4	32.1
24	MI3C	Install occ. sensors to control lighting- offices/100	\$6,700	28	-	-	\$210	0.4	35.2
25	BP16	Install pony boiler	\$100,600	-	517	-	\$1,400	0.2	80.7
26	LT4B2	Replace MVs with metal halides	\$3,150	12	-	(\$80)	(\$1,030)	0.1	308.3
27	BE2	Install insulated glass or double-glazed windows	\$242,000	2	62	-	\$200	0.0	999
28	BP1	Reduce steam distribution pressure from 60 to 30 p	\$25,800	(2,413)	3,432	-	(\$9,100)	0.0	999
29	BP8	Install air heater	-	(82)	3,691	-	\$9,300	0.0	999
30	MI4	Natural gas desiccant cooling	\$176,900	833	(2,804)	-	(\$1,200)	-0.2	999

\* Fuel oil

Table 4.1-4 ECO Evaluations Summary - Ordered by Payback

No.	ECO ID	Description	Construction Cost	Energy Elec.	Annual Savings NGas	O&M	Annual Cost Savings	SIR	Simple Payback (yrs)
1	HS24	Surgical suite supply air reset	\$1,400	738	1,984	-	\$11,000	108.0	0.1
2	LT2	Reduce lighting levels	\$5,500	1,158	-	-	\$8,800	19.6	0.7
3	HS18	Reduce heated or cooled outside air	\$1,100	136	32	-	\$1,100	12.7	1.1
4	BP3	Increase boiler efficiency (repair controls)	\$24,000	-	6,706	-	\$18,100	11.6	1.5
5	LT4C2	Retrofit compact floor's in lobby downlights.	\$1,100	13	-	\$500	\$600	6.6	2.0
6	MI3B	Install occ. sensors to control lighting-breakrooms.	\$1,900	999	-	-	\$7,600	4.9	2.8
7	BP17	Install new unattended boilers	\$427,800	-	8,971	\$120,000	\$144,200	4.1	3.3
8	LT4C1	Retrofit compact floor's in restrooms.	\$37,500	231	-	\$8,500	\$10,300	3.3	4.0
9	EL4	Use emergency generator to reduce demand	\$182,400	15	(416)*	\$65,200	\$67,900	3.0	4.3
10	BP15	Install oxygen trim controls	\$9,900	-	640	-	\$1,700	2.7	6.4
11	HS13	Use damper controls to shut off air to unoccupied ar	\$111,500	2,041	1,505	-	\$19,600	2.3	6.4
12	MI3A	Install occ. sensors to control lighting- restrooms/10	\$14,900	259	-	-	\$2,000	1.6	8.5
13	EL6	Convert to energy efficient motors	\$17,200	284	-	-	\$2,200	1.5	8.9
14	LT4A1	Retrofit with T-8s & elect. ballasts - hallways/100	\$5,900	90	-	-	\$700	1.4	9.6
15	BP7	Install economizer	\$104,100	(82)	3,691	-	\$9,300	1.4	12.5
16	LT4A2	Retrofit with T-8s & elect. ballasts - patient rooms/1	\$5,900	60	-	-	\$450	1.0	14.5
17	HS7	Install variable air volume controls	\$329,600	2,472	1,880	-	\$23,900	0.9	15.4
18	MI3C	Install occ. sensors to control lighting- offices/100	\$6,600	62	-	-	\$500	0.9	15.7
19	EL3	Increase power factor	\$76,800	-	-	-	\$4,900	0.7	17.8
20	LT4B1	Replace MVs with T-8 fixtures	\$830	4	-	\$9	\$42	0.6	22.3
21	KI8	Install energy efficient kitchen exhaust hoods	\$138,700	(532)	4,032	-	\$6,800	0.9	22.7
22	KI5	Install heat reclamation system for exhaust heat	\$87,700	(395)	2,630	-	\$4,100	0.8	24.0
23	LT4A3	Retrofit with T-8s & elect. ballasts - offices/100	\$5,900	27	-	-	\$200	0.4	32.1
24	MI3C	Install occ. sensors to control lighting- offices/100	\$6,700	28	-	-	\$210	0.4	35.2
25	BP16	Install pony boiler	\$100,600	-	517	-	\$1,400	0.2	80.7
26	LT4B2	Replace MVs with metal halides	\$3,150	12	-	(\$80)	(\$1,030)	0.1	308.3
27	BE2	Install insulated glass or double-glazed windows	\$242,000	2	62	-	\$200	0.0	999
28	BP1	Reduce steam distribution pressure from 60 to 30 p	\$25,800	(2,413)	3,432	-	(\$9,100)	0.0	999
29	BP8	Install air heater	-	(82)	3,691	-	\$9,300	0.0	999
30	MI4	Natural gas desiccant cooling	\$176,900	833	(2,804)	-	(\$1,200)	-0.2	999

Table 4.1-4 ECO Evaluations Summary - Ordered by Payback

No.	ECO ID	Description	Construction Cost	Energy Elec.	Annual Savings (MBtu/yr)	Annual Savings Elec.	Annual Savings NGas	O&M	Annual Cost Savings	SIR	Simple Payback (yrs)
1	HS24	Surgical suite supply air reset	\$1,400	738	1,984	-	-	-	\$11,000	108.0	0.1
2	LT2	Reduce lighting levels	\$5,500	1,158	-	-	-	-	\$8,800	19.6	0.7
3	HS18	Reduce heated or cooled outside air	\$1,100	136	32	-	-	-	\$1,100	12.7	1.1
4	BP3	Increase boiler efficiency (repair controls)	\$24,000	-	6,706	-	-	-	\$18,100	11.6	1.5
5	LT4C2	Retrofit compact floor's in lobby downlights.	\$1,100	13	-	-	-	\$500	\$600	6.6	2.0
6	MI3B	Install occ. sensors to control lighting-breakrooms.	\$1,900	999	-	-	-	-	\$7,600	4.9	2.8
7	BP17	Install new unattended boilers	\$427,800	-	8,971	-	\$120,000	-	\$144,200	4.1	3.3
8	LT4C1	Retrofit compact floor's in restrooms.	\$37,500	231	-	-	\$8,500	-	\$10,300	3.3	4.0
9	EL4	Use emergency generator to reduce demand	\$182,400	15	(416)*	-	\$65,200	-	\$67,900	3.0	4.3
10	BP15	Install oxygen trim controls	\$9,900	-	640	-	-	-	\$1,700	2.7	6.4
11	HS13	Use damper controls to shut off air to unoccupied ar	\$111,500	2,041	1,505	-	-	-	\$19,600	2.3	6.4
12	MI3A	Install occ. sensors to control lighting- restrooms/10	\$14,900	259	-	-	-	-	\$2,000	1.6	8.5
13	EL6	Convert to energy efficient motors	\$17,200	284	-	-	-	-	\$2,200	1.5	8.9
14	LT4A1	Retrofit with T-8s & elect. ballasts - hallways/100	\$5,900	90	-	-	-	-	\$700	1.4	9.6
15	BP7	Install economizer	\$104,100	(82)	3,691	-	-	-	\$9,300	1.4	12.5
16	LT4A2	Retrofit with T-8s & elect. ballasts - patient rooms/1	\$5,900	60	-	-	-	-	\$450	1.0	14.5
17	HS7	Install variable air volume controls	\$329,600	2,472	1,880	-	-	-	\$23,900	0.9	15.4
18	MI3C	Install occ. sensors to control lighting- offices/100	\$6,600	62	-	-	-	-	\$500	0.9	15.7
19	EL3	Increase power factor	\$76,800	-	-	-	-	-	\$4,900	0.7	17.8
20	LT4B1	Replace MVs with T-8 fixtures	\$830	4	-	-	-	\$9	\$42	0.6	22.3
21	KI8	Install energy efficient kitchen exhaust hoods	\$138,700	(532)	4,032	-	-	-	\$6,800	0.9	22.7
22	KI5	Install heat reclamation system for exhaust heat	\$87,700	(395)	2,630	-	-	-	\$4,100	0.8	24.0
23	LT4A3	Retrofit with T-8s & elect. ballasts - offices/100	\$5,900	27	-	-	-	-	\$200	0.4	32.1
24	MI3C	Install occ. sensors to control lighting- offices/100	\$6,700	28	-	-	-	-	\$210	0.4	35.2
25	BP16	Install pony boiler	\$100,600	-	517	-	-	-	\$1,400	0.2	80.7
26	LT4B2	Replace MVs with metal halides	\$3,150	12	-	-	(\$80)	-	(\$1,030)	0.1	308.3
27	BE2	Install insulated glass or double-glazed windows	\$242,000	2	62	-	-	-	\$200	0.0	999
28	BP1	Reduce steam distribution pressure from 60 to 30 p	\$25,800	(2,413)	3,432	-	-	-	(\$9,100)	0.0	999
29	BP8	Install air heater	-	(82)	3,691	-	-	-	\$9,300	0.0	999
30	MI4	Natural gas desiccant cooling	\$176,900	833	(2,804)	-	-	-	(\$1,200)	-0.2	999

\* Fuel oil

Table 4.1-5 Qualifying ECOs - Ordered by SIR

No.	ECO ID	Description	Construction			Annual Savings			Annual Cost Savings	SIR	Simple Payback (yrs)
			Cost	Energy Elec.	NGas	O&M					
1	HS24	Surgical suite supply air reset	\$1,400	738	1,984	-	-	\$11,000	108.0	0.1	
2	LT2	Reduce lighting levels	\$5,500	1,158	-	-	-	\$8,800	19.6	0.7	
3	HS18	Reduce heated or cooled outside air	\$1,100	136	32	-	-	\$1,100	12.7	1.1	
4	BP3	Increase boiler efficiency (repair controls)	\$24,000	-	6,706	-	-	\$18,100	11.6	1.5	
5	LT4C2	Retrofit compact fluor's in lobby downlights.	\$1,100	13	-	\$500	-	\$600	6.6	2.0	
6	MI3B	Install occ. sensors to control lighting-breakrooms.	\$1,900	999	-	-	-	\$7,600	4.9	2.8	
7	BP17	Install new unattended boilers	\$427,800	-	8,971	-	\$120,000	\$144,200	4.1	3.3	
8	LT4C1	Retrofit compact fluor's in restrooms.	\$37,500	231	-	\$8,500	-	\$10,300	3.3	4.0	
9	EL4	Use emergency generator to reduce demand	\$182,400	15	(416)*	\$65,200	-	\$67,900	3.0	4.3	
10	BP15	Install oxygen trim controls	\$9,900	-	640	-	-	\$1,700	2.7	6.4	
11	HS13	Use damper controls to shut off air to unoccupied areas	\$111,500	2,041	1,505	-	-	\$19,600	2.3	6.4	
12	MI3A	Install occ. sensors to control lighting- restrooms/100	\$14,900	259	-	-	-	\$2,000	1.6	8.5	
13	EL6	Convert to energy efficient motors	\$17,200	284	-	-	-	\$2,200	1.5	8.9	
14	LT4A1	Retrofit with T-8s & elect. ballasts - hallways/100	\$5,900	90	-	-	\$0	\$700	1.4	9.6	

\* Fuel oil

Table 4.1-6 ECOs Not Qualifying - Ordered by SIR

No.	ECO ID	Description	Construction			Annual Savings			Annual Cost Savings	SIR	Simple Payback (yrs)
			Cost	Energy Elec.	NGas	O&M					
1	BP7	Install economizer	\$104,100	(82)	3,691	-	-	\$9,300	1.4	12.5	
2	LT4A2	Retrofit with T-8s & elect. ballasts - patient rms/100	\$5,900	60	-	-	-	\$450	1.0	14.5	
3	HS7	Install variable air volume controls	\$329,600	2,472	1,880	-	-	\$23,900	0.9	15.4	
4	MI3C	Install occ. sensors to control lighting- offices/100	\$6,600	62	-	-	-	\$500	0.9	15.7	
5	K18	Install energy efficient kitchen exhaust hoods	\$138,700	(532)	4,032	-	-	\$6,800	0.9	22.7	
6	K15	Install heat reclamation system for exhaust heat	\$87,700	(395)	2,630	-	-	\$4,100	0.8	24.0	
7	EL3	Increase power factor	\$76,800	-	-	-	-	\$4,900	0.7	17.8	
8	LT4B1	Replace MV's with T-8 fixtures	\$830	4	-	\$9	-	\$42	0.6	22.3	
9	LT4A3	Retrofit with T-8s & elect. ballasts - offices/100	\$5,900	27	-	-	-	\$200	0.4	32.1	
10	MI3C	Install occ. sensors to control lighting- offices/100	\$6,700	28	-	-	-	\$210	0.4	35.2	
11	BP16	Install pony boiler	\$100,600	-	517	-	-	\$1,400	0.2	80.7	
12	LT4B2	Replace MV's with metal halides	\$3,150	12	-	(\$80)	-	(\$1,030)	0.1	308.3	
13	BE2	Install insulated glass or double-glazed windows	\$242,000	2	62	-	-	\$200	0.0	999	
14	BP1	Reduce steam distribution pres. from 60 to 30 psig	\$25,800	(2,413)	3,432	-	-	(\$9,100)	0.0	999	
15	BP8	Install air heater	-	(82)	3,691	-	-	\$9,300	0.0	999	
16	MI4	Natural gas desiccant cooling	\$176,900	833	(2,804)	-	-	(\$1,200)	-0.2	999	

## 4.2 MULTIPLE ECO PROJECT EVALUATIONS

### FEMP1 - Energy Saving Projects

The first FEMP project combines the following ECOs:

EL6	Convert to energy-efficient motors
HS13	Use damper controls to shut off air to unoccupied areas
HS18	Reduce heated or cooled outside air
HS24	Surgical suite supply air reset
LT2	Reduce lighting levels
LT4C1	Retrofit compact fluorescents in restrooms
LT4C2	Retrofit compact fluorescents in lobby downlights
MI3B	Install occupancy sensors to control lighting in breakrooms

### Results

Construction Costs	\$177,200
Annual Utility Savings (Increase)	
Electricity (Mbtu/Year)	5,600
Natural Gas (Mbtu/Year)	3,521
Annual Energy Cost Savings (Increase)	\$52,200
Savings to Investment Ratio (SIR)	4.4
Simple Payback (Years)	3.2

$$\frac{177,200}{3.2} = 55,375$$
  
$$\frac{55,375}{-52,200} = 3.195$$
  
3.195 O&M savings

## 4.3 OPERATION AND MAINTENANCE RECOMMENDATIONS

This section is divided into two parts. The first section covers those recommendations that should be covered by the 1996 Major Renovation Project. The second section includes those recommendations that are pertinent even after the Renovation Project is completed. A list of the items discussed are below.

### Affected by Renovation Project

1. HVAC:
  - a) Straighten AHU Cooling Coils and Repair Damper Linkages
  - b) Correct Building Air Balance
2. Boilers:
  - a) Repair Economizers
  - b) Clean Boiler Tubes
  - c) Repair Fuel-to-Air Ratio Controls

- d) Replace Missing Steam Line and Duct Insulation
3. Cooling Tower:
- a) Repair Float Valves

**Not Affected by Renovation Project**

1. HVAC:
- a) Clean Chilled Water Distribution Line Surfaces
  - b) Clean Kitchen MAU Coil
  - c) Reduce Overcooling Through Thermostat Adjustments
2. Boilers:
- a) Improve Fuel Oil Firing Operation
  - b) Reduce Boiler Pressure to 60 psig
  - c) Improve Feedwater Pump Operation
  - d) Improve Boiler Water Chemistry
  - e) Repair and Maintain Steam Lines and Traps
  - f) Reduce Boiler Water Make-Up
  - g) Renovate Hospital Low Pressure Regulating Valve Station
  - h) Verify Steam Flow Chart Calibration
  - l) Improve Atomizing Steam Problems
3. Lighting:
- a) Replace Exit Sign Incandescent Lamps on Failure
  - b) Turn Off Lights When Not Needed
  - c) Maintain Low Harmonics in Electronic-Ballasted Lighting Systems
4. Lightning Protection:
- a) Repair Deficiencies

## 5.0 ENERGY PLAN

### 5.1 PROJECT PACKAGING

The ECOs in Table 4.1-5 were evaluated for their appropriate funding category. The scope of work lists the following guidelines for project funding.

- Federal Energy Management Program (FEMP)  
These projects are limited to \$300,000 for construction and \$1,000,000 for those classified as maintenance and repair. Any recommended project must have, as a minimum, a Savings-to-Investment Ratio (SIR) of 1.25 and a simple payback of 10 years or less.
- Energy Conservation Investment Program (ECIP) Projects  
These projects are for new construction or retrofit of an existing facility with costs greater than those listed above for FEMP. The project must have an SIR greater than 1.25 and a simple payback less than ten years.

Table 5.1-1 lists the ECOs that are recommended for funding. Although the total costs of all ECOs is greater than the \$300,000 ECIP minimum, ECO #EL4 - Use Emergency Generator to Reduce Demand does not qualify for ECIP funds. This ECO has very little energy savings. Its savings come from a credit paid by the electric utility.

### 5.2 ENERGY AND COST SAVINGS

Two FEMP projects were developed and are shown in Tables 5.2-1 and 5.2-2. Together, the two projects produce annual savings of 5,615 MBtu of electricity and 3,521 MBtu of natural gas. Fuel oil use is increased slightly (416 MBtu/yr). Annual O&M savings, which include demand cost reductions and utility credits, are \$74,200 per year. Total annual savings are \$129,100. The total savings are 5.9% in energy and 11.1% in energy costs.

When the FY96 Major Renovation Project is included, the annual savings are:

Combined Project Savings (Includes FY96 Major Renovation Project)				
Fuel	Energy (MBTU)	%	Cost (\$)	%
Natural Gas	11,100	14.2	\$ 29,300	14.0
Electricity	13,700	16.5	229,700	21.2
TOTAL	24,800	15.4	\$259,000	20.0

Table 5.1-1 Recommended ECOs - Ordered by SIR

No.	ECO ID	Description	Construction		Annual Savings			Annual Cost Savings	SIR	Simple Payback (Yrs)
			Cost	Energy Elec.	NGas	O&M				
1	HS24	Surgical suite supply air reset	\$1,400	738	1,984	-	\$11,000	108.0	0.1	
2	LT2	Reduce lighting levels	\$5,500	1,158	-	-	\$8,800	19.6	0.7	
3	HS18	Reduce heated or cooled outside air	\$1,100	136	32	-	\$1,100	12.7	1.1	
4	LT4C2	Retrofit compact fluor's in lobby downlights.	\$1,100	13	-	\$500	\$600	6.6	2.0	
5	MI3B	Install occ. sensors to control lighting-breakrooms.	\$1,900	999	-	-	\$7,600	4.9	2.8	
6	LT4C1	Retrofit compact fluor's in restrooms.	\$37,500	231	-	\$8,500	\$10,300	3.3	4.0	
7	EL4	Use emergency generator to reduce demand	\$182,400	15	(416)*	\$65,200	\$67,900	3.0	4.3	
8	HS13	Use damper controls to shut off air to unoccupied air	\$111,500	2,041	1,505	-	\$19,600	2.3	6.4	
9	EL6	Convert to energy efficient motors	\$17,200	284	-	-	\$2,200	1.5	8.9	
Totals			\$359,600	5,615	3,105	\$74,200	\$129,100			

\* Fuel oil

Table 5.2-1 FEMP #1 - Energy Saving Project

No.	ECO ID	Description	Construction Cost	Annual Savings Energy (MBtu/yr)	Annual Savings NGas	Annual Savings O&M	Annual Cost Savings	SIR	Simple Payback (yrs)
1	HS24	Surgical suite supply air reset	\$1,400	738	1,984	-	\$11,000	108.0	0.1
2	LT2	Reduce lighting levels	\$5,500	1,158	-	-	\$8,800	19.6	0.7
3	HS18	Reduce heated or cooled outside air	\$1,100	136	32	-	\$1,100	12.7	1.1
4	LT4C2	Retrofit compact fluor's in lobby downlights.	\$1,100	13	-	\$500	\$600	6.6	2.0
5	MI3B	Install occ. sensors to control lighting-breakrooms.	\$1,900	999	-	-	\$7,600	4.9	2.8
6	LT4C1	Retrofit compact fluor's in restrooms.	\$37,500	231	-	\$8,500	\$10,300	3.3	4.0
7	HS13	Use damper controls to shut off air to unoccupied air	\$111,500	2,041	1,505	-	\$19,600	2.3	6.4
8	EL6	Convert to energy efficient motors	\$17,200	284	-	-	\$2,200	1.5	8.9
Totals			\$177,200	5,600	3,521	\$9,000	\$61,200	4.4	3.2

Table 5.2-2 FEMP #2 - Emergency Generator Paralleling

No.	ECO ID	Description	Construction Cost	Annual Savings Energy (MBtu/yr)	Annual Savings Fuel Oil	Annual Savings O&M	Annual Cost Savings	SIR	Simple Payback (yrs)
7	EL4	Use emergency generator to reduce demand	\$182,400	15	(416)	\$65,200	\$67,900	3.0	4.3
Totals			\$182,400	15	(416)	\$65,200	\$67,900	3.0	4.3

The following ECOs were not recommended since the FY 96 Renovation Project was recently modified (in May 1996) to replace existing boilers with new ones.

- BP3 Increase boiler efficiency (repair controls)
- BP15 Install oxygen trim controls
- BP17 Install new unattended boilers

ECO #MI3A - Install Occupancy Sensors to Control Lighting in Restrooms - was removed also. The simple payback period was less than ten years only for restrooms that controlled at least three two-lamp fixtures with one switch. No restrooms meet this criterion.

ECO #LT4A1 - Retrofit Hallway Lighting with T8 Lamps and Electronic Ballasts - was also removed. The EAMC is currently involved in a project to accomplish this.